



**FCC 47 CFR PART 15 SUBPART C
INDUSTRY CANADA RSS-210 ISSUE 8**

**BLUETOOTH LOW ENERGY
CERTIFICATION TEST REPORT**

FOR

iPOD TOUCH

MODEL NUMBER: A1574

**FCC ID: BCGA1574
IC: 579C-A1574**

REPORT NUMBER: 15U20058-E2, REVISION E

ISSUE DATE: MAY 27, 2015

Prepared for
**APPLE, INC.
1 INFINITE LOOP
CUPERTINO, CA 95014, U.S.A.**

Prepared by
**UL VERIFICATION SERVICES INC.
47173 BENICIA STREET
FREMONT, CA 94538, U.S.A.
TEL: (510) 771-1000
FAX: (510) 661-0888**



NVLAP LAB CODE 200065-0

Revision History

<u>Rev.</u>	<u>Issue Date</u>	<u>Revisions</u>	<u>Revised By</u>
--	05/05/2015	Initial Issue	M. Mekuria
A	05/15/2015	Revised report due to power increased and updated EUT name.	T. Chu
B	05/29/2015	Revised report to address TCB's questions	T. Chu
C	06/02/2015	Revised report to address TCB's questions	T. Chu
D	06/03/2015	Revised report to address TCB's questions	T. Chu
E	06/08/2015	Revised issue date to MAY 27, 2015	C. Pang

TABLE OF CONTENTS

1. ATTESTATION OF TEST RESULTS	5
2. TEST METHODOLOGY	6
3. FACILITIES AND ACCREDITATION	6
4. CALIBRATION AND UNCERTAINTY	7
4.1. MEASURING INSTRUMENT CALIBRATION	7
4.2. SAMPLE CALCULATION	7
4.3. MEASUREMENT UNCERTAINTY.....	7
5. EQUIPMENT UNDER TEST	8
5.1. DESCRIPTION OF EUT	8
5.2. MAXIMUM OUTPUT POWER.....	8
5.3. DESCRIPTION OF AVAILABLE ANTENNAS	8
5.4. SOFTWARE AND FIRMWARE.....	8
5.5. WORST-CASE CONFIGURATION AND MODE.....	9
5.6. DESCRIPTION OF TEST SETUP.....	10
6. TEST AND MEASUREMENT EQUIPMENT	14
7. ANTENNA PORT TEST RESULTS	15
7.1. MEASUREMENT METHODS	15
7.2. ON TIME, DUTY CYCLE	16
7.2.1. ON TIME AND DUTY CYCLE RESULTS.....	16
7.2.2. DUTY CYCLE PLOTS	17
7.3. 6 dB BANDWIDTH.....	18
7.4. 99% BANDWIDTH.....	21
7.5. AVERAGE POWER.....	24
7.6. OUTPUT POWER.....	25
7.7. POWER SPECTRAL DENSITY	26
7.8. CONDUCTED SPURIOUS EMISSIONS.....	29
8. RADIATED TEST RESULTS.....	33
8.1. LIMITS AND PROCEDURE.....	33
8.2. TRANSMITTER ABOVE 1 GHz.....	34
8.2.1. RESTRICTED BANDEDGE	34
8.2.2. HARMONICS AND SPURIOUS EMISSIONS	38
8.3. WORST-CASE BELOW 1 GHz.....	44
8.4. WORST-CASE 18 to 26 GHz.....	46

9. AC POWER LINE CONDUCTED EMISSIONS47

10. SETUP PHOTOS50

1. ATTESTATION OF TEST RESULTS

COMPANY NAME: APPLE, INC.
1 INFINITE LOOP
CUPERTINO, CA 95014, U.S.A.

EUT DESCRIPTION: IPOD TOUCH

MODEL: A1574

SERIAL NUMBER: CCQP704HGJ1Y (CONDUCTED); CCQP704KGJ1Y (RADIATED)

DATE TESTED: MARCH 20, 2015 – May 11, 2015

APPLICABLE STANDARDS	
STANDARD	TEST RESULTS
CFR 47 Part 15 Subpart C	Pass
INDUSTRY CANADA RSS-210 Issue 8 Annex 8	Pass
INDUSTRY CANADA RSS-GEN Issue 4	Pass

UL Verification Services Inc. tested the above equipment in accordance with the requirements set forth in the above standards. All indications of Pass/Fail in this report are opinions expressed by UL Verification Services Inc. based on interpretations and/or observations of test results. Measurement Uncertainties were not taken into account and are published for informational purposes only. The test results show that the equipment tested is capable of demonstrating compliance with the requirements as documented in this report.

Note: The results documented in this report apply only to the tested sample, under the conditions and modes of operation as described herein. This document may not be altered or revised in any way unless done so by UL Verification Services Inc. and all revisions are duly noted in the revisions section. Any alteration of this document not carried out by UL Verification Services Inc. will constitute fraud and shall nullify the document. This report must not be used by the client to claim product certification, approval, or endorsement by NVLAP, NIST, any agency of the Federal Government, or any agency of any government.

Approved & Released For
UL Verification Services Inc. By:

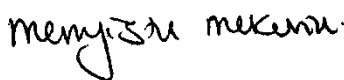

MENGISTU MEKURIA
SENIOR ENGINEER
UL VERIFICATION SERVICES INC.

Tested By:



TRI PHAM
LAB TECHNICIAN
UL VERIFICATION SERVICES INC.

2. TEST METHODOLOGY

The tests documented in this report were performed in accordance with FCC CFR 47 Part 2, FCC CFR 47 Part 15, RSS-GEN Issue 4, and RSS-210 Issue 8, and ANSI C63.10-2009 for FCC test and ANSI C63.10-2013 with deviation of measurement height of 0.8m rather than 1.5m for IC test.

3. FACILITIES AND ACCREDITATION

The test sites and measurement facilities used to collect data are located at 47173 and 47266 Benicia Street, Fremont, California, USA. Line conducted emissions are measured only at the 47173 address. The following table identifies which facilities were utilized for radiated emission measurements documented in this report. Specific facilities are also identified in the test results sections.

47173 Benicia Street	47266 Benicia Street
<input type="checkbox"/> Chamber A	<input type="checkbox"/> Chamber D
<input type="checkbox"/> Chamber B	<input checked="" type="checkbox"/> Chamber E
<input type="checkbox"/> Chamber C	<input type="checkbox"/> Chamber F
	<input type="checkbox"/> Chamber G
	<input type="checkbox"/> Chamber H

The above test sites and facilities are covered under FCC Test Firm Registration # 208313. Chambers A through H are covered under Industry Canada company address code 2324B with site numbers 2324B -1 through 2324B-8, respectively.

UL Verification Services Inc. is accredited by NVLAP, Laboratory Code 200065-0. The full scope of accreditation can be viewed at <http://ts.nist.gov/standards/scopes/2000650.htm>.

4. CALIBRATION AND UNCERTAINTY

4.1. MEASURING INSTRUMENT CALIBRATION

The measuring equipment utilized to perform the tests documented in this report has been calibrated in accordance with the manufacturer's recommendations, and is traceable to recognized national standards.

4.2. SAMPLE CALCULATION

Where relevant, the following sample calculation is provided:

$$\begin{aligned} \text{Field Strength (dBuV/m)} &= \text{Measured Voltage (dBuV)} + \text{Antenna Factor (dB/m)} + \\ &\text{Cable Loss (dB)} - \text{Preamp Gain (dB)} \\ 36.5 \text{ dBuV} + 18.7 \text{ dB/m} + 0.6 \text{ dB} - 26.9 \text{ dB} &= 28.9 \text{ dBuV/m} \end{aligned}$$

4.3. MEASUREMENT UNCERTAINTY

Where relevant, the following measurement uncertainty levels have been estimated for tests performed on the apparatus:

PARAMETER	UNCERTAINTY
Conducted Disturbance, 0.15 to 30 MHz	± 3.52 dB
Radiated Disturbance, 30 to 1000 MHz	± 4.94 dB
Radiated Disturbance, 1 to 6 GHz	± 3.86 dB
Radiated Disturbance, 6 to 18 GHz	± 4.23 dB
Radiated Disturbance, 18 to 26 GHz	± 5.30 dB
Radiated Disturbance, 26 to 40 GHz	± 5.23 dB

Uncertainty figures are valid to a confidence level of 95%.

5. EQUIPMENT UNDER TEST

5.1. DESCRIPTION OF EUT

EUT is a multimedia device with IEEE 802.11a/b/g/n/ac and BLUETOOTH Radio.

5.2. MAXIMUM OUTPUT POWER

The transmitter has a maximum peak conducted output power as follows:

Frequency Range (MHz)	Mode	Output Power (dBm)	Output Power (mW)
2402 - 2480	BLE	9.42	8.75

5.3. DESCRIPTION OF AVAILABLE ANTENNAS

Frequency Band (GHz)	Antenna Gain
2.400-2.480	-0.452

5.4. SOFTWARE AND FIRMWARE

The firmware installed in the EUT during testing was 12.4.312.1014.

5.5. WORST-CASE CONFIGURATION AND MODE

Radiated emission and power line conducted emission were performed with the EUT set to transmit at the channel with highest output power as worst-case scenario.

The following configurations were investigated and EUT powered by AC/DC adapter was the worst-case scenario. AC power line and below 1G radiated tests were conducted on configuration 1.

Configuration	Descriptions
1	EUT powered by AC/DC adapter via USB cable
2	EUT powered by host PC via USB cable

The fundamental of the EUT was investigated in three orthogonal orientations X/Y/Z, it was determined that X-flatbed orientation was worst-case orientation; therefore, all final radiated testing was performed with the EUT in X-flatbed orientation.

Worst-case data rates as provided by the client were:
Based on the baseline scan, the worst-case data rates were:

BLE: 1 Mbps.

For the co-location test, no other emissions were found after the conducted measurement with all different combination frequencies between BT & 5GHz bands were investigated.

5.6. DESCRIPTION OF TEST SETUP

SUPPORT EQUIPMENT

Support Equipment List				
Description	Manufacturer	Model	Serial Number	FCC ID
Laptop	Dell	Latitude 3540	D49G802	NA
Laptop AC/DC adapter	Dell	HA65NM130	CN-06TFFF-75661-426-030Y-A00	NA
Earphone	Apple	NA	NA	NA
EUT AC/DC adapter	Apple	A1265	1X3276SZZ08QZ	NA

I/O CABLES (CONDUCTED TEST)

I/O Cable List						
Cable No	Port	# of identical ports	Connector Type	Cable Type	Cable Length (m)	Remarks
1	Antenna	1	SMA	Un-Shielded	0.2	To spectrum Analyzer
2	USB	1	USB	Shielded	1	N/A

I/O CABLES (RADIATED ABOVE 1 GHZ)

I/O Cable List						
Cable No	Port	# of identical ports	Connector Type	Cable Type	Cable Length (m)	Remarks
None used						

I/O CABLES (AC POWER CONDUCTED TEST and below 1 GHZ)

I/O Cable List						
Cable No	Port	# of identical ports	Connector Type	Cable Type	Cable Length (m)	Remarks
1	AC	1	US115	Un-Shielded	0.8	NA
2	DC	1	lightning	Un-Shielded	1	NA
3	Audio	1	Jack	Un-Shielded	0.5	NA

TEST SETUP- CONDUCTED PORT

The EUT was tested connected to a host Laptop via USB cable adapter and spectrum analyzer to antenna port. Test software exercised the EUT.

SETUP DIAGRAM

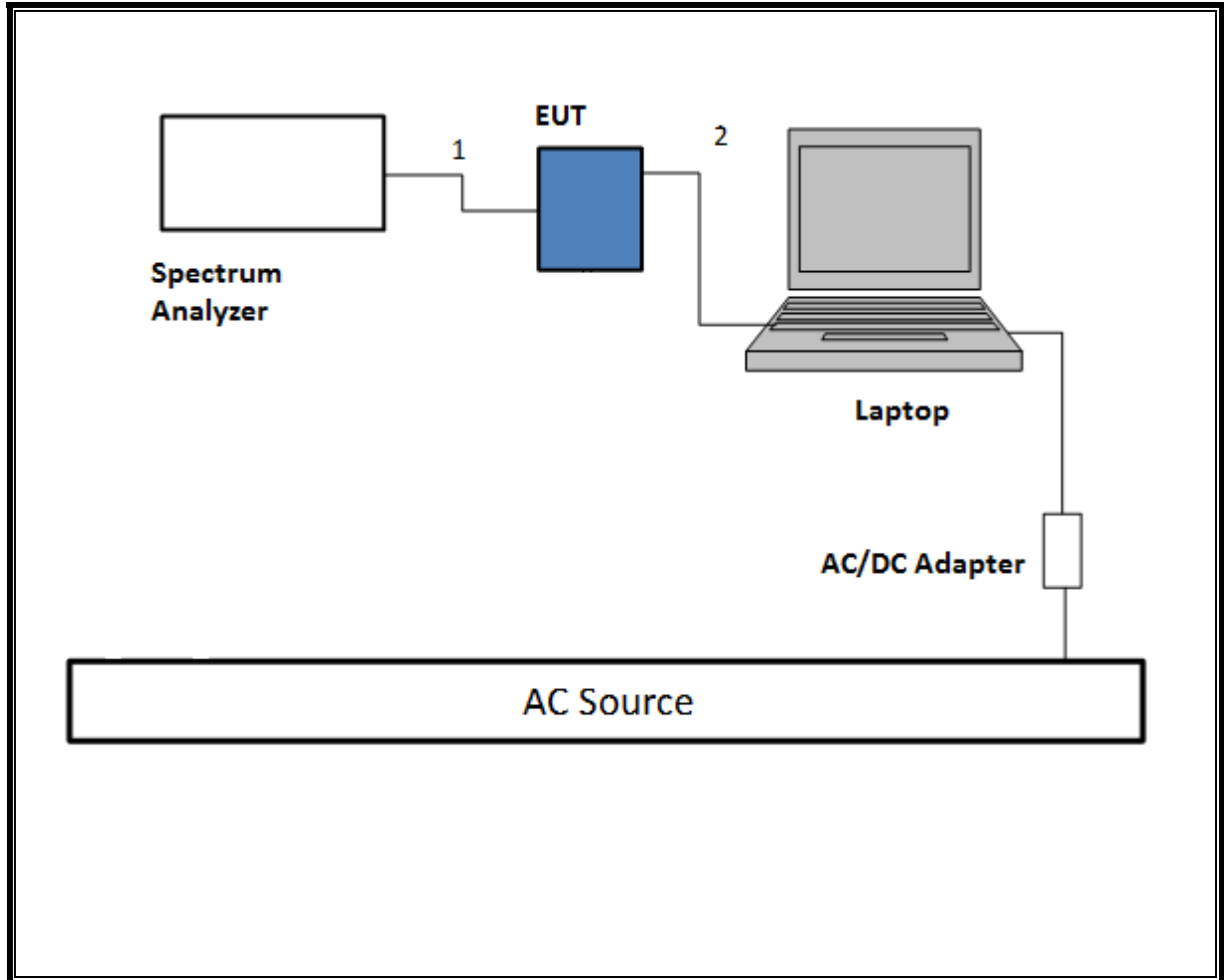

TEST SETUP- RADIATED-ABOVE 1 GHZ

The EUT was tested battery powered. Test software exercised the EUT.

SETUP DIAGRAM

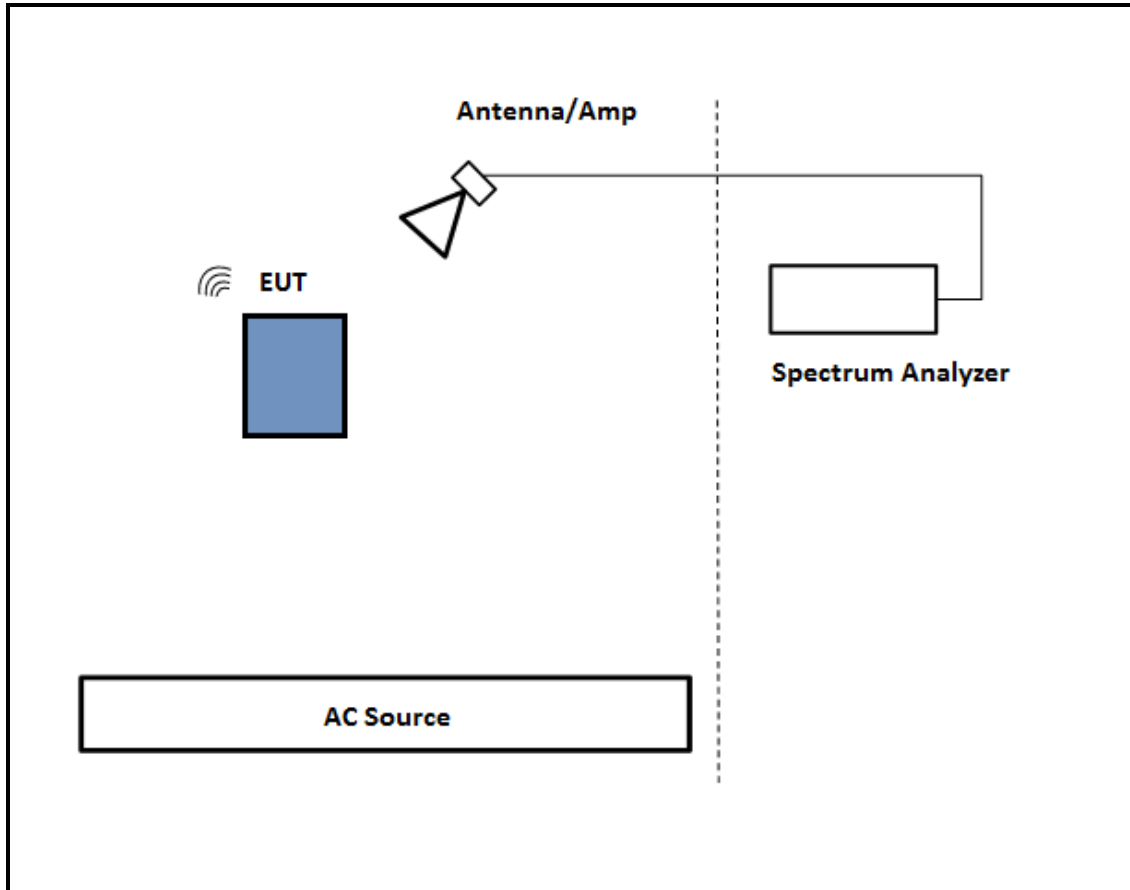

TEST SETUP- BELOW 1GHZ & AC LINE CONDUCTED TESTS

The EUT was tested with earphone connected and powered by AC adapter. Test software exercised the EUT.

SETUP DIAGRAM

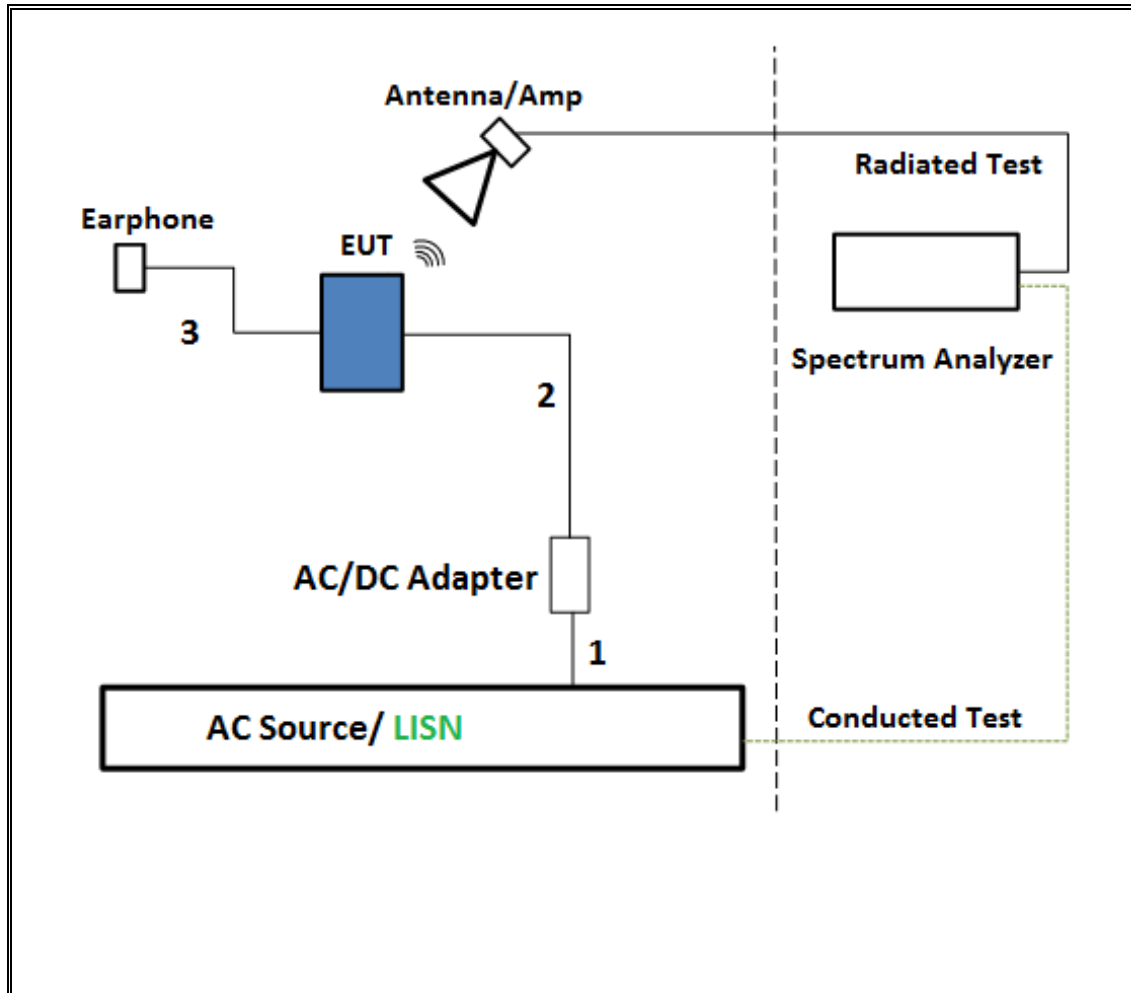

6. TEST AND MEASUREMENT EQUIPMENT

The following test and measurement equipment was utilized for the tests documented in this report:

Test Equipment List				
Description	Manufacturer	Model	Cal Date	Cal Due
Antenna, Horn 1-18GHz	ETS Lindgren	3117	2/10/2015	2/10/2016
Antenna, Broadband Hybrid, 30MHz to 2000MHz	Sunol Sciences	JB3	1/14/2015	1/14/2016
Amplifier, 1 - 18GHz	Miteq	AFS42-00101800-25-S-42	1/26/2015	1/26/2016
Amplifier, 10KHz to 1GHz, 32dB	Sonoma	310N	5/28/2014	5/28/2015
Spectrum Analyzer, PXA, 3Hz to 44GHz	Agilent	N9030A	12/23/2014	12/23/2015
Power Meter, P-series single channel	Agilent	N1911A	10/9/2014	10/9/2015
Power Sensor, P - series, 50MHz to 18GHz, Wideband	Agilent	N1921A	7/12/2014	7/12/2015
Antenna, Horn 18 to 26.5GHz	ARA	MWH-1826	12/17/2014	12/17/2015
Spectrum Analyzer, 40 GHz	Agilent	8564E	8/6/2014	8/6/2015
Amplifier, 1 to 26.5GHz, 23.5dB Gain minimum	Agilent	8449B	10/4/2014	10/4/2015
AC Line Conducted				
EMI Test Receiver 9Khz-7GHz	Rohde & Schwarz	ECSI7	09/16/14	09/16/15
LISN for Conducted Emissions CISPR-16	FCC	50/250-25-2	01/16/15	01/16/16
Power Cable, Line Conducted Emissions ANSI 63.4	UL	PG1	7/28/2014	7/28/2015
UL SOFTWARE				
Radiated Software	UL	UL EMC	Ver 9.5, July 22, 2014	
Conducted Software	UL	UL EMC	Ver 2.1.3, March 12, 2015, Ver 2.2, March 31, 2015	
AC Line Conducted Software	UL	UL EMC	Ver 9.5, February 26, 2015	

7. ANTENNA PORT TEST RESULTS

7.1. MEASUREMENT METHODS

MEASUREMENT METHODS

6 dB BW: KDB 558074 D01 v03r02, Section 8.1.

Output Power: KDB 558074 D01 v03r02, Section 9.1.2.

Power Spectral Density: KDB 558074 D01 v03r02, Section 10.2.

Out-of-band emissions in non-restricted bands: KDB 558074 D01 v03r02, Section 11.0.

Out-of-band emissions in restricted bands: KDB 558074 D01 v03r02, Section 12.1.

Band-edge: KDB 558074 D01 v03r02, Section 12.1

7.2. ON TIME, DUTY CYCLE

LIMITS

None; for reporting purposes only.

PROCEDURE

KDB 558074 Zero-Span Spectrum Analyzer Method.

7.2.1. ON TIME AND DUTY CYCLE RESULTS

Mode	ON Time B (msec)	Period (msec)	Duty Cycle x (linear)	Duty Cycle (%)	Duty Cycle Correction Factor (dB)	1/B Minimum VBW (kHz)
BLE	5.000	5.000	1.000	100.00%	0.00	0.010

7.2.2. DUTY CYCLE PLOTS

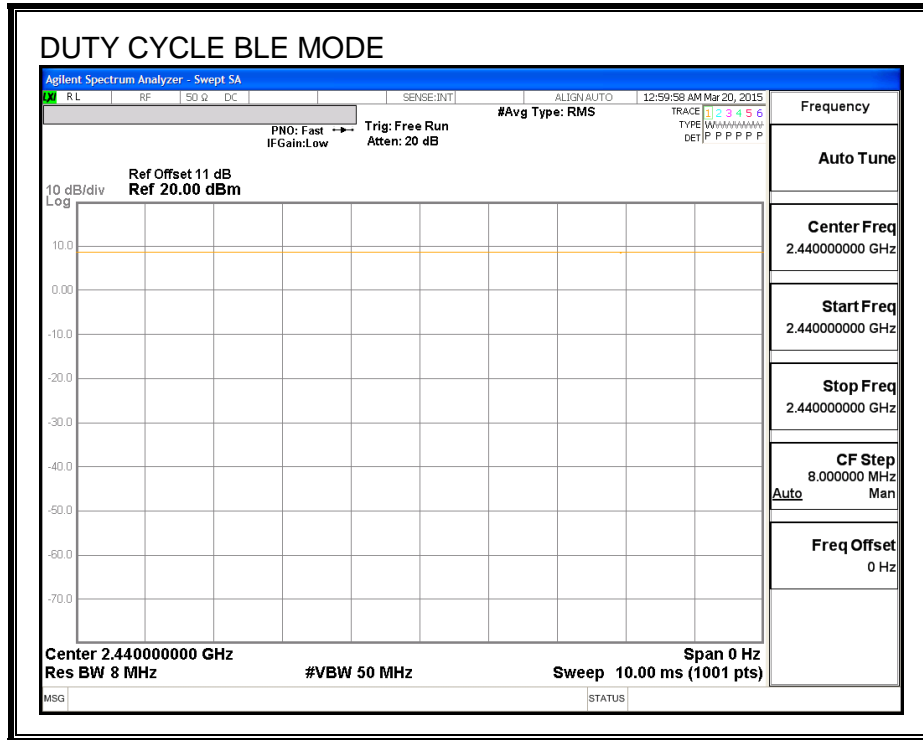

7.3. 6 dB BANDWIDTH

LIMITS

FCC §15.247 (a) (2)

IC RSS-210 A8.2 (a)

The minimum 6 dB bandwidth shall be at least 500 kHz.

RESULTS

Channel	Frequency (MHz)	6 dB Bandwidth (MHz)	Minimum Limit (MHz)
Low	2402	0.729	0.5
Middle	2440	0.727	0.5
High	2480	0.736	0.5

6 dB BANDWIDTH

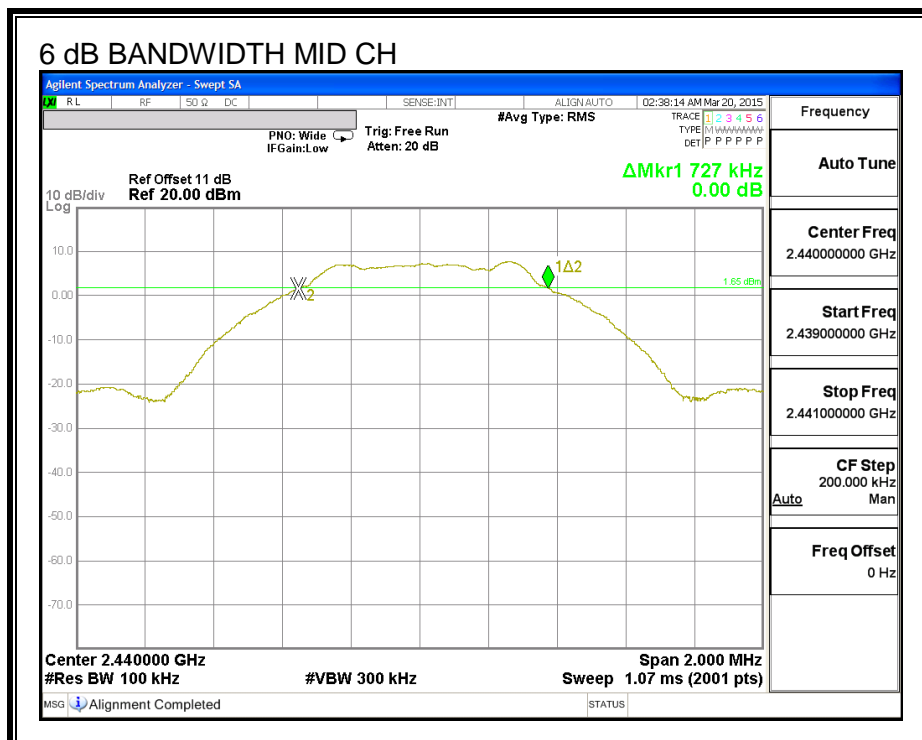
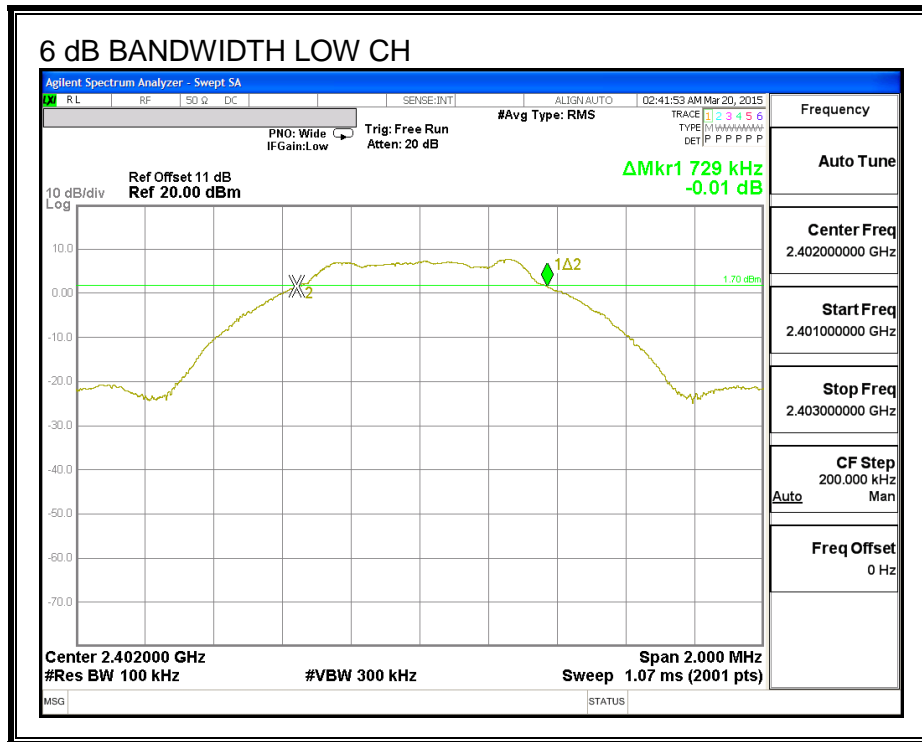

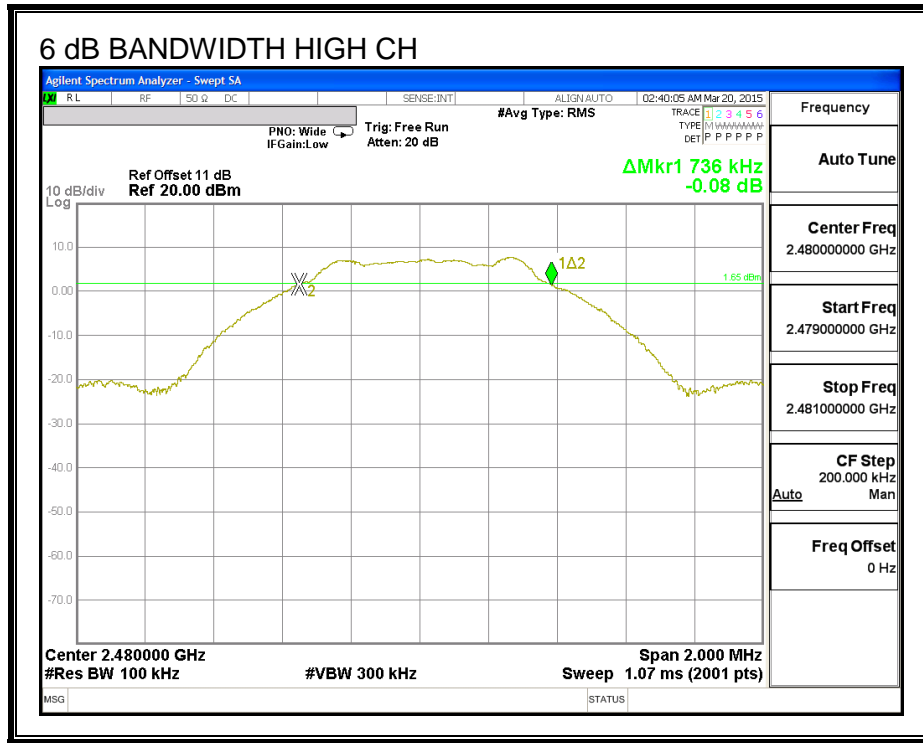

7.4. 99% BANDWIDTH

LIMITS

None; for reporting purposes only.

TEST PROCEDURE

The transmitter output is connected to the spectrum analyzer. The RBW is set to 1% to 3% of the 99 % bandwidth and to 1% of the span. The VBW is set to 3 times the RBW. The sweep time is coupled. The spectrum analyzer internal 99% bandwidth function is utilized.

RESULTS

Channel	Frequency (MHz)	99% Bandwidth (MHz)
Low	2402	1.0938
Middle	2440	1.0649
High	2480	1.0739

99% BANDWIDTH

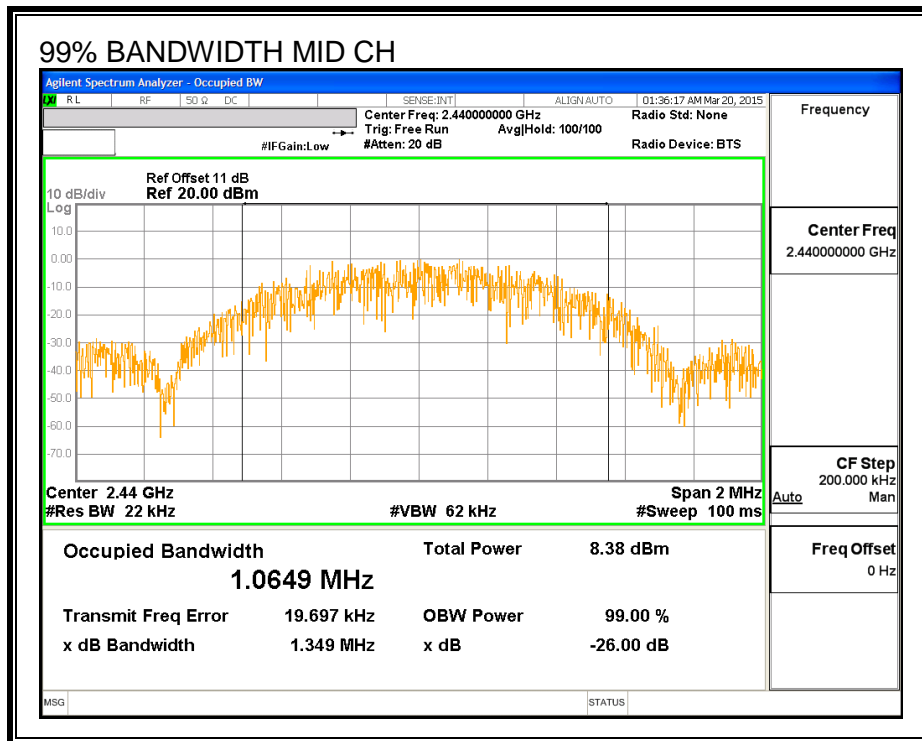
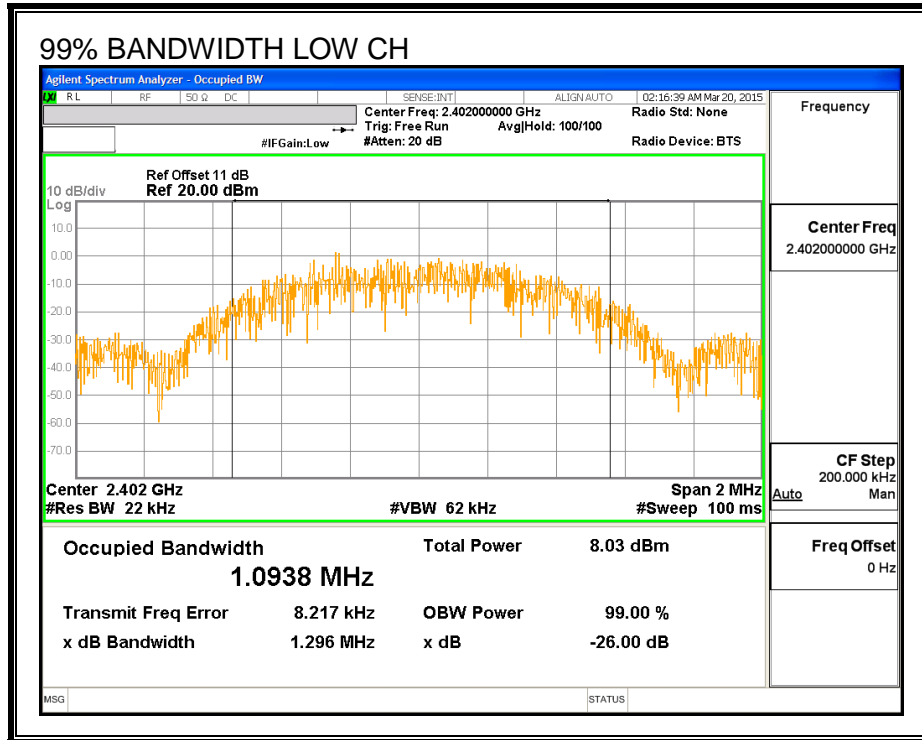

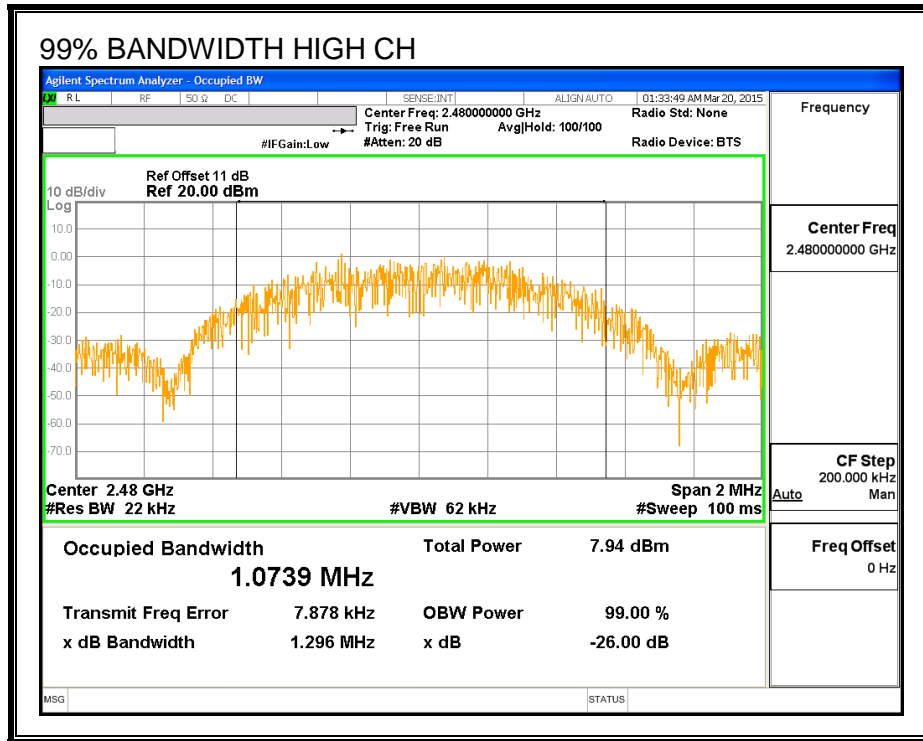

7.5. AVERAGE POWER

LIMITS

None; for reporting purposes only.

RESULTS

The cable assembly insertion loss of 11 dB (including 10 dB pad and 1 dB cable) was entered as an offset in the power meter to allow for direct reading of power.

Channel	Frequency (MHz)	AV power (dBm)
Low	2402	9.13
Middle	2440	8.99
High	2480	8.91

7.6. OUTPUT POWER

LIMITS

FCC §15.247 (b)

IC RSS-210 A8.4

The maximum antenna gain is less than or equal to 6 dBi, therefore the limit is 30 dBm.

RESULTS

Channel	Frequency (MHz)	Peak Power Reading (dBm)	Limit (dBm)	Margin (dB)
Low	2402	9.42	30	-20.580
Middle	2440	9.30	30	-20.700
High	2480	9.24	30	-20.760

7.7. POWER SPECTRAL DENSITY

LIMITS

FCC §15.247 (e)

IC RSS-210 A8.2 (b)

The power spectral density conducted from the transmitter to the antenna shall not be greater than 8 dBm in any 3 kHz band during any time interval of continuous transmission.

RESULTS

Channel	Frequency (MHz)	PSD (dBm)	Limit (dBm)	Margin (dB)
Low	2402	-7.14	8	-15.14
Middle	2440	-7.47	8	-15.47
High	2480	-7.53	8	-15.53

POWER SPECTRAL DENSITY

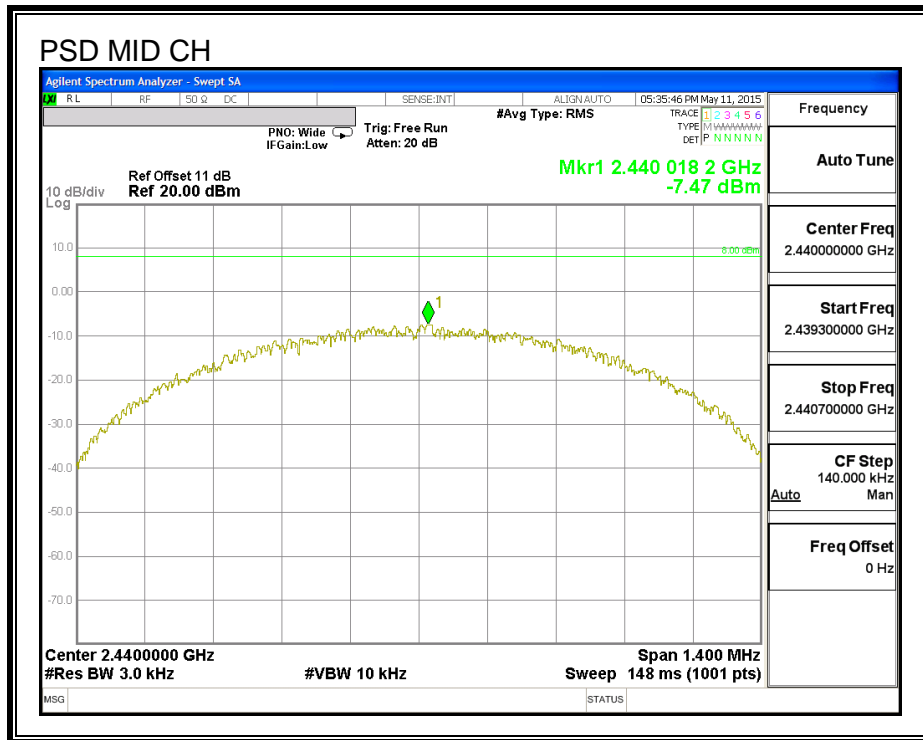
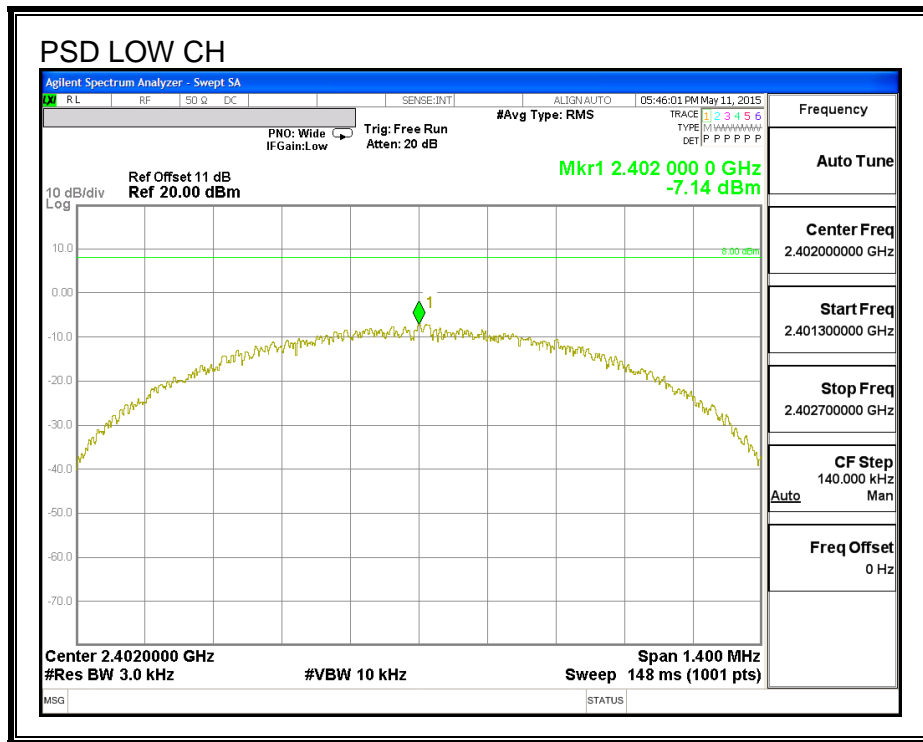

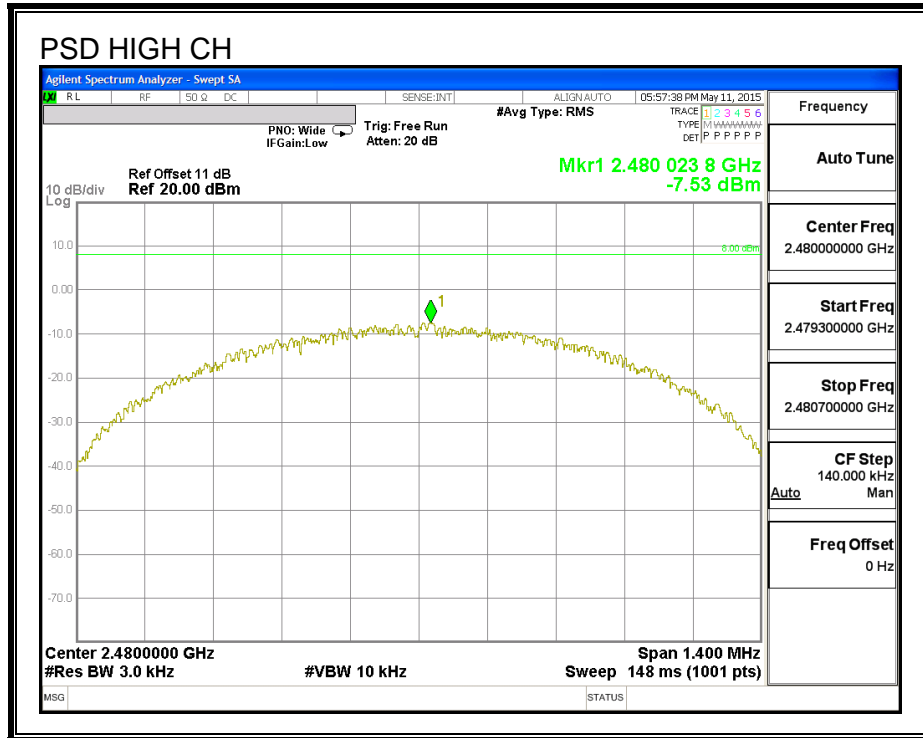

7.8. CONDUCTED SPURIOUS EMISSIONS

LIMITS

FCC §15.247 (d)

IC RSS-210 A8.5

Output power was measured based on the use of a peak measurement, therefore the required attenuation is 20 dB.

RESULTS

SPURIOUS EMISSIONS, LOW CHANNEL

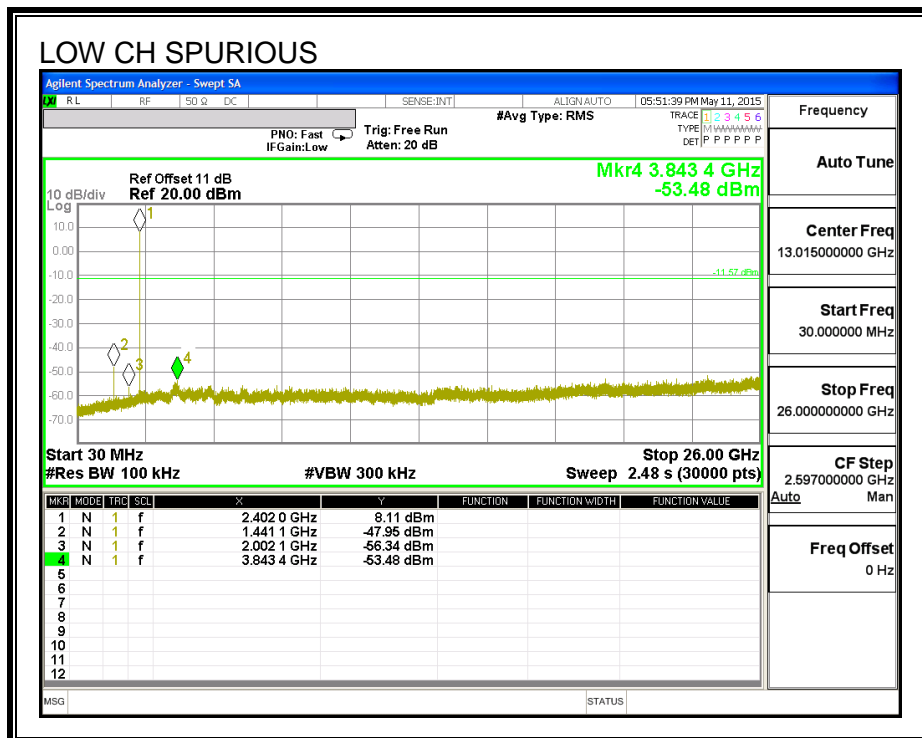
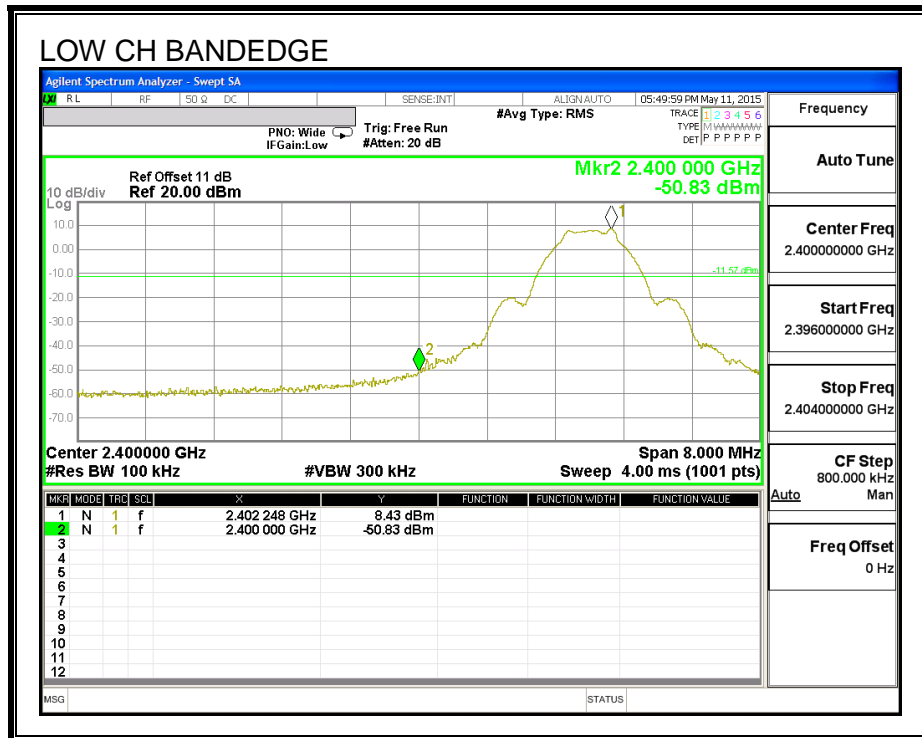

SPURIOUS EMISSIONS, MID CHANNEL

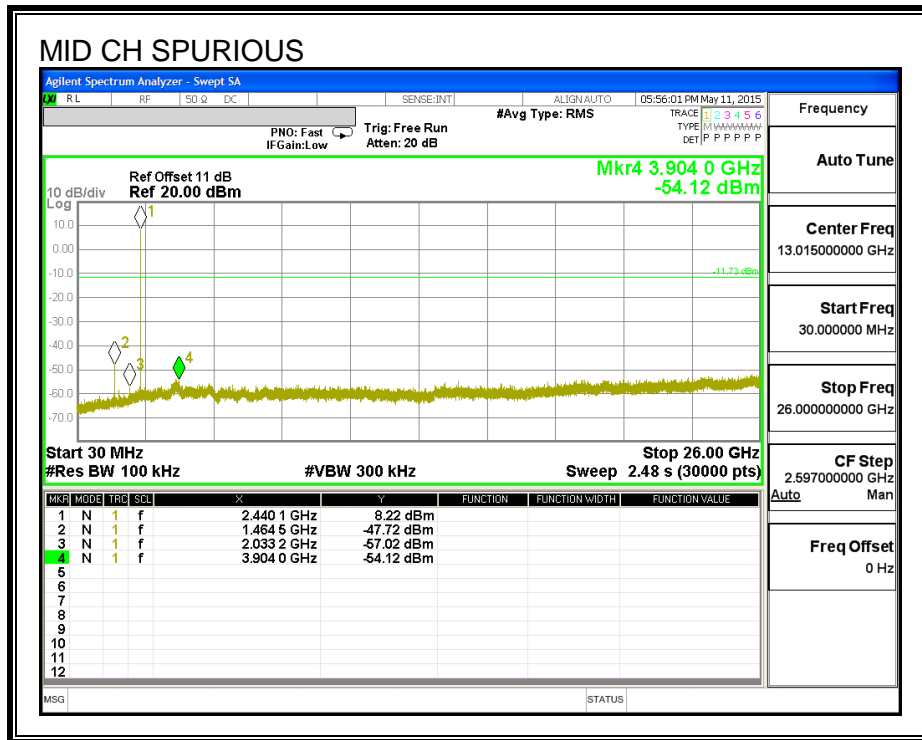
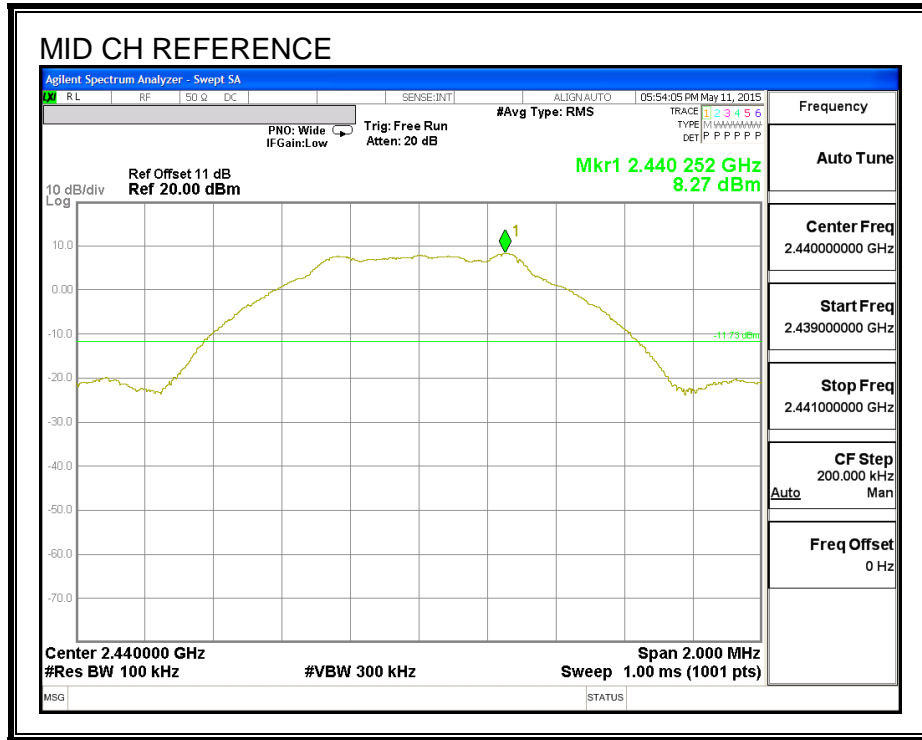

SPURIOUS EMISSIONS, HIGH CHANNEL

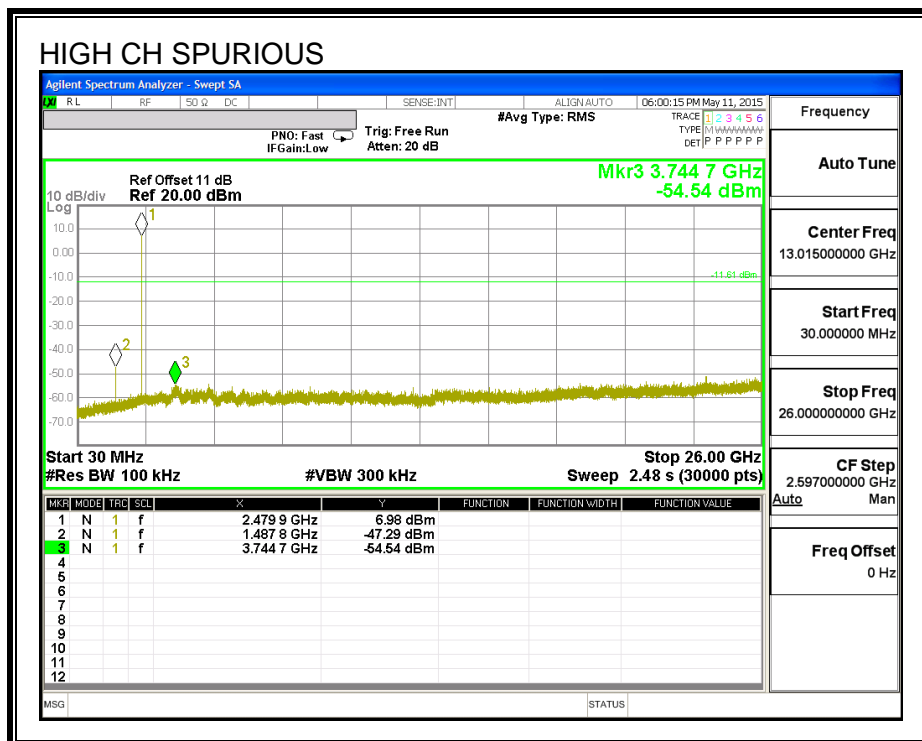
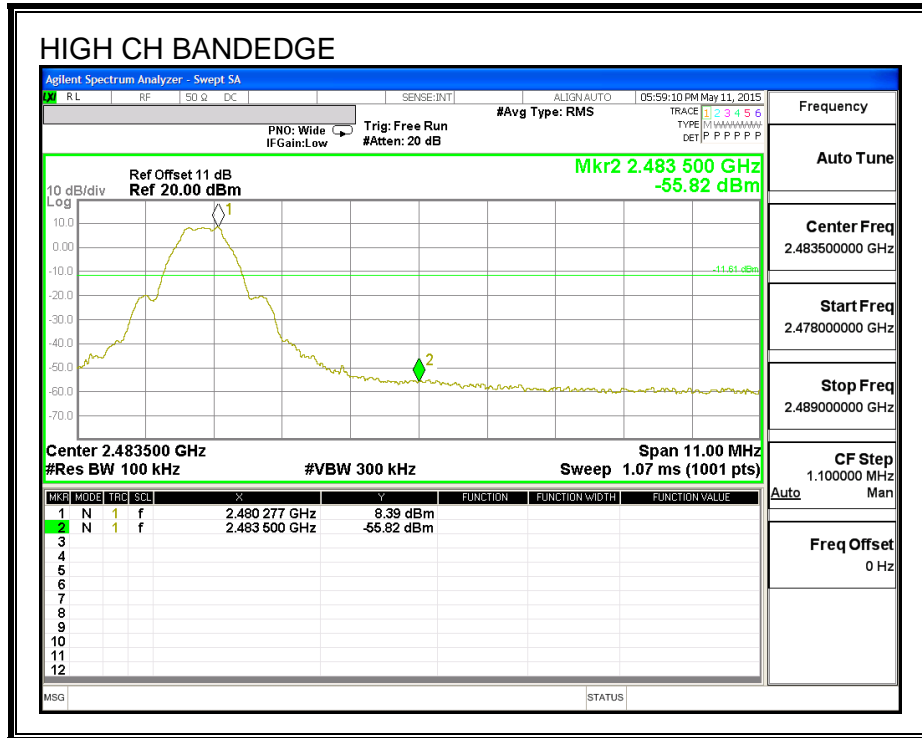

8. RADIATED TEST RESULTS

8.1. LIMITS AND PROCEDURE

LIMITS

FCC §15.205 and §15.209

IC RSS-GEN, Section 8.9 and 8.10.

Frequency Range (MHz)	Field Strength Limit (uV/m) at 3 m	Field Strength Limit (dBuV/m) at 3 m
30 - 88	100	40
88 - 216	150	43.5
216 - 960	200	46
Above 960	500	54

Frequency Range (MHz)	Field Strength Limit (uV/m) at 3 m	Field Strength Limit (dBuV/m) at 3 m
30 - 88	100	40
88 - 216	150	43.5
216 - 960	200	46
Above 960	500	54

TEST PROCEDURE

The EUT is placed on a non-conducting table 80 cm above the ground plane. The antenna to EUT distance is 3 meters. The EUT is configured in accordance with ANSI C63.10. The EUT is set to transmit in a continuous mode.

For measurements below 1 GHz the resolution bandwidth is set to 100 kHz for peak detection measurements or 120 kHz for quasi-peak detection measurements. Peak detection is used unless otherwise noted as quasi-peak.

For measurements above 1 GHz the resolution bandwidth is set to 1 MHz, then the video bandwidth is set to 3 MHz for peak measurements and 1 MHz resolution bandwidth with 3MHz video bandwidth with average detector for average measurements.

The spectrum from 30 MHz to 26 GHz is investigated with the transmitter set to the lowest, middle, and highest channels in the 2.4 GHz band.

The frequency range of interest is monitored at a fixed antenna height and EUT azimuth. The EUT is rotated through 360 degrees to maximize emissions received. The antenna is scanned from 1 to 4 meters above the ground plane to further maximize the emission. Measurements are made with the antenna polarized in both the vertical and the horizontal positions.

8.2. TRANSMITTER ABOVE 1 GHz

8.2.1. RESTRICTED BANDEGE

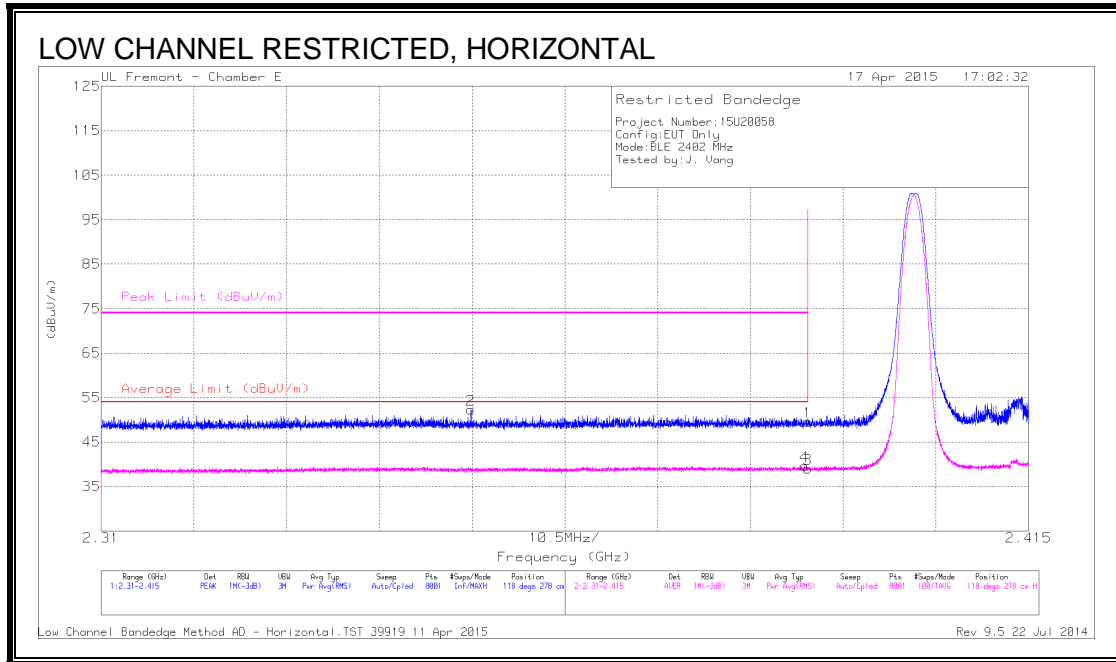

DATA

Marker	Frequency (GHz)	Meter Reading (dBuV)	Det	AF T346 (dB/m)	Amp/Cbl/Ftr/Pad (dB)	Corrected Reading (dBuV/m)	Average Limit (dBuV/m)	Margin (dB)	Peak Limit (dBuV/m)	PK Margin (dB)	Azimuth (Degs)	Height (cm)	Polarity
2	* 2.352	44.94	PK	32	-24.7	52.24	-	-	74	-21.76	118	278	H
1	* 2.39	42.11	PK	32.1	-24.7	49.51	-	-	74	-24.49	118	278	H
3	* 2.39	31.63	RMS	32.1	-24.7	39.03	54	-14.97	-	-	118	278	H
4	* 2.39	32.17	RMS	32.1	-24.7	39.57	54	-14.43	-	-	118	278	H

* - indicates frequency in CFR 47, Part 15 and Industry Canada RSS-Restricted Band.

PK - Peak detector

RMS - RMS detection

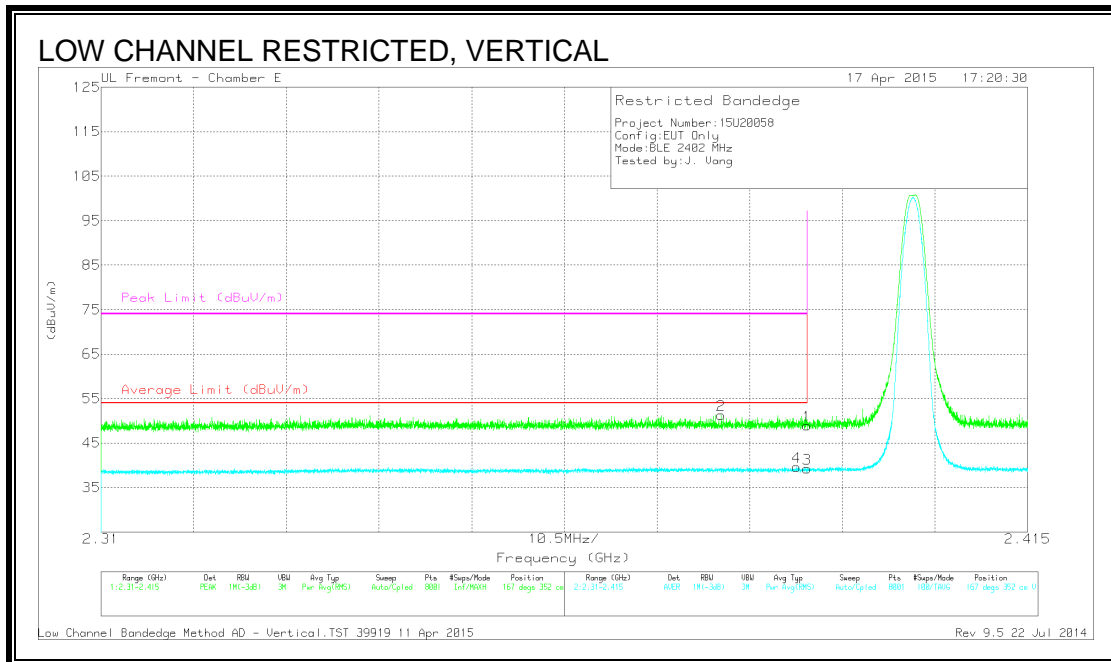

DATA

Marker	Frequency (GHz)	Meter Reading (dBuV)	Det	AF T346 (dB/m)	Amp/Cbl/Filtr/Pad (dB)	Corrected Reading (dBuV/m)	Average Limit (dBuV/m)	Margin (dB)	Peak Limit (dBuV/m)	PK Margin (dB)	Azimuth (Degs)	Height (cm)	Polarity
2	* 2.38	43.93	PK	32	-24.6	51.33	-	-	74	-22.67	167	352	V
4	* 2.389	32.19	RMS	32.1	-24.7	39.59	54	-14.41	-	-	167	352	V
1	* 2.39	41.57	PK	32.1	-24.7	48.97	-	-	74	-25.03	167	352	V
3	* 2.39	31.83	RMS	32.1	-24.7	39.23	54	-14.77	-	-	167	352	V

* - indicates frequency in CFR 47, Part 15 and Industry Canada RSS-Restricted Band.

PK - Peak detector

RMS - RMS detection

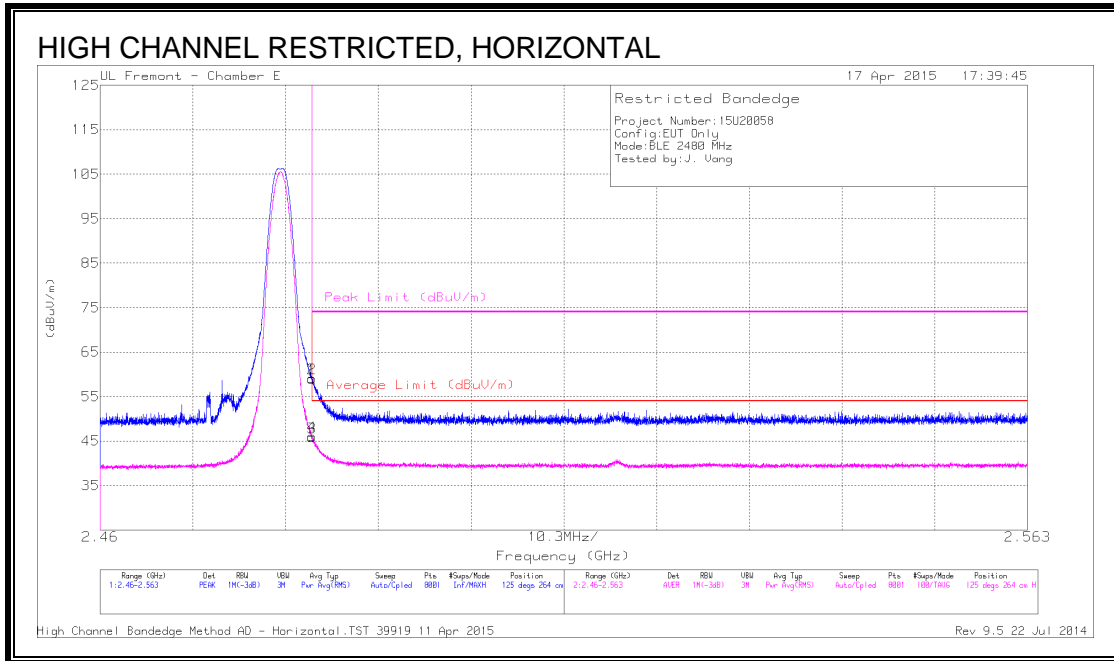

DATA

Marker	Frequency (GHz)	Meter Reading (dBuV)	Det	AF T346 (dB/m)	Amp/Cbl/ Fitr/Pad (dB)	Corrected Reading (dBuV/m)	Average Limit (dBuV/m)	Margin (dB)	Peak Limit (dBuV/m)	PK Margin (dB)	Azimuth (Degs)	Height (cm)	Polarity
1	* 2.484	51.06	PK	32.2	-24.3	58.96	-	-	74	-15.04	125	264	H
2	* 2.484	51.16	PK	32.2	-24.3	59.06	-	-	74	-14.94	125	264	H
3	* 2.484	37.92	RMS	32.2	-24.3	45.82	54	-8.18	-	-	125	264	H
4	* 2.484	38.21	RMS	32.2	-24.3	46.11	54	-7.89	-	-	125	264	H

* - indicates frequency in CFR 47, Part 15 and Industry Canada RSS-Restricted Band.

PK - Peak detector

RMS - RMS detection

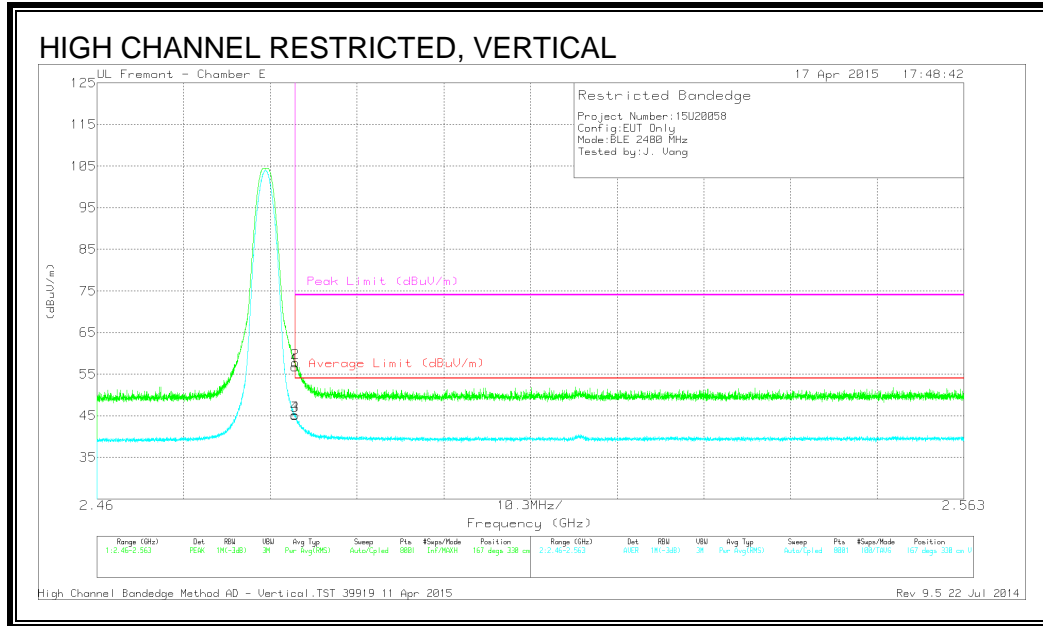

DATA

Marker	Frequency (GHz)	Meter Reading (dBuV)	Det	AF T346 (dB/m)	Amp/Cbl/Fitr/Pad (dB)	Corrected Reading (dBuV/m)	Average Limit (dBuV/m)	Margin (dB)	Peak Limit (dBuV/m)	PK Margin (dB)	Azimuth (Degs)	Height (cm)	Polarity
1	* 2.484	48.86	PK	32.2	-24.3	56.76	-	-	74	-17.24	167	330	V
2	* 2.484	49.87	PK	32.2	-24.3	57.77	-	-	74	-16.23	167	330	V
3	* 2.484	37.18	RMS	32.2	-24.3	45.08	54	-8.92	-	-	167	330	V
4	* 2.484	37.32	RMS	32.2	-24.3	45.22	54	-8.78	-	-	167	330	V

* - indicates frequency in CFR 47, Part 15 and Industry Canada RSS-Restricted Band.

PK - Peak detector

RMS - RMS detection

8.2.2. HARMONICS AND SPURIOUS EMISSIONS

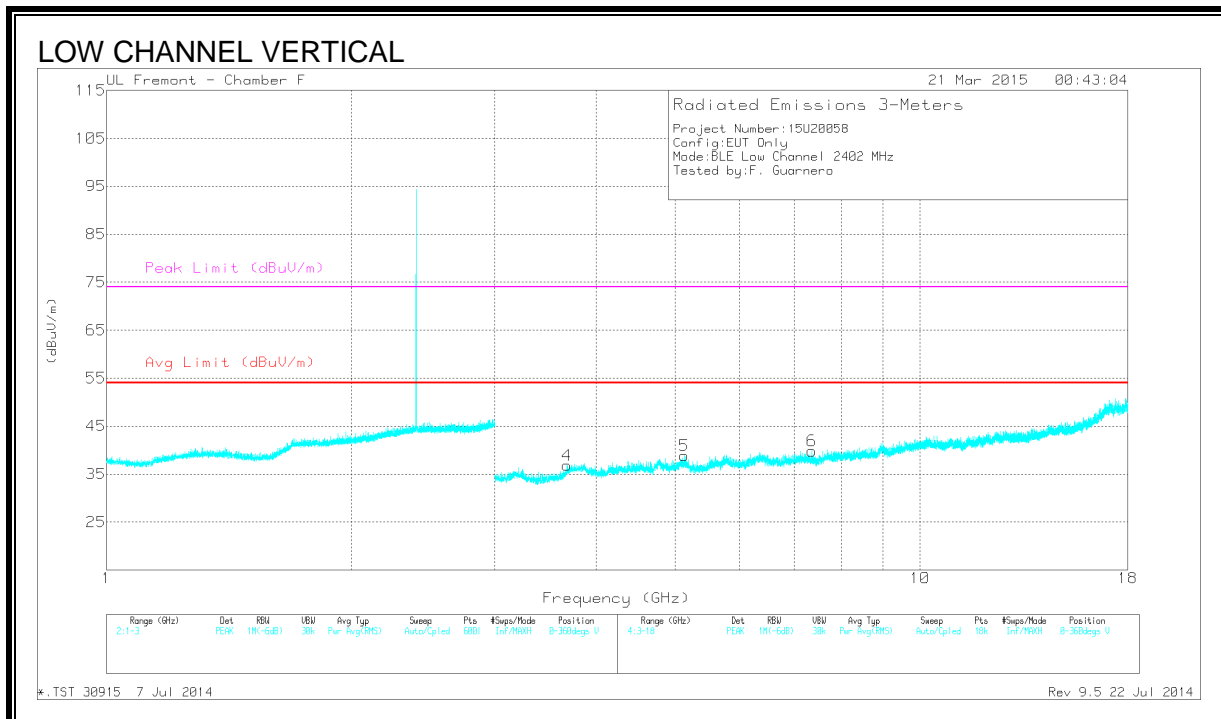
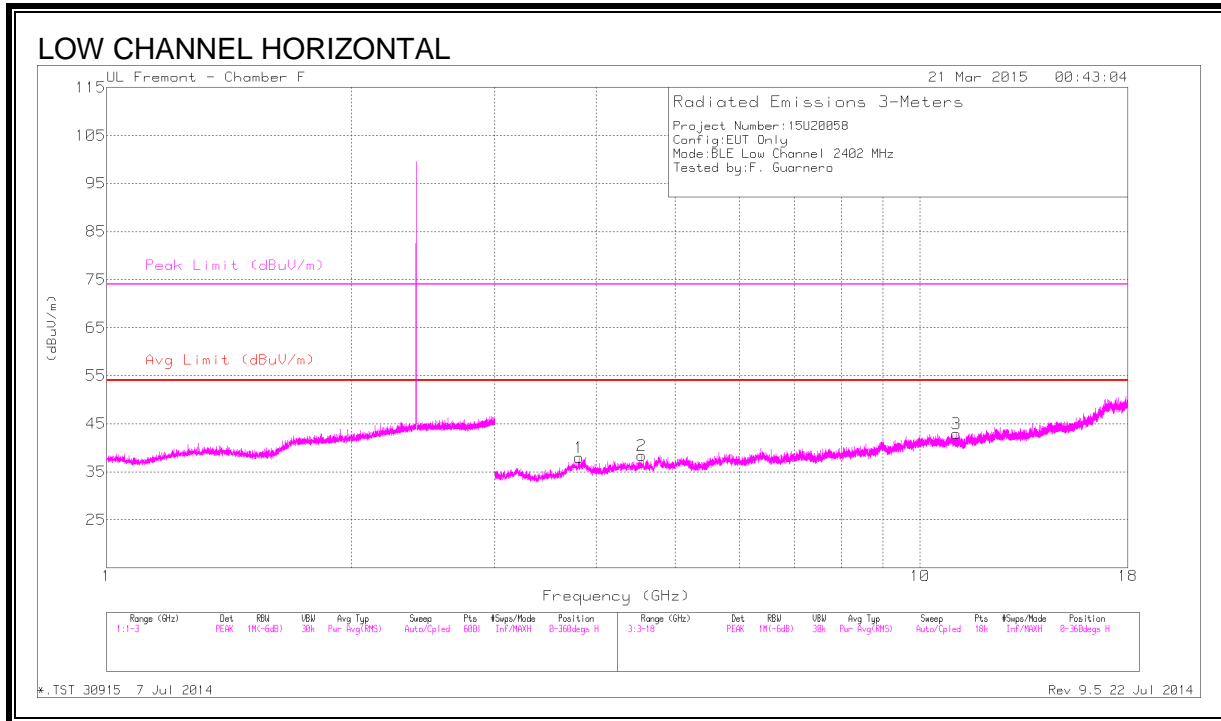

DATA

Marker	Frequency (GHz)	Meter Reading (dBuV)	Det	AF T712 (dB/m)	Amp/Cbl/ Filtr/Pad (db)	Corrected Reading (dBuV/m)	Avg Limit (dBuV/m)	Margin (dB)	Peak Limit (dBuV/m)	PK Margin (dB)	Azimuth (Degs)	Height (cm)	Polarity
1	* 3.809	39.25	PK2	33.1	-28.6	43.75	-	-	74	-30.25	208	142	H
	* 3.811	27.34	MAv1	33.1	-28.6	31.84	54	-22.16	-	-	208	142	H
2	* 4.55	38.95	PK2	33.8	-27.9	44.85	-	-	74	-29.15	195	156	H
	* 4.551	27.39	MAv1	33.8	-27.9	33.29	54	-20.71	-	-	195	156	H
3	* 11.073	34.11	PK2	37.3	-22.3	49.11	-	-	74	-24.89	244	161	H
	* 11.07	23.69	MAv1	37.3	-22.3	38.69	54	-15.31	-	-	244	161	H
4	* 3.681	38.63	PK2	33	-29.2	42.43	-	-	74	-31.57	62	112	H
	* 3.682	27.24	MAv1	33	-29.2	31.04	54	-22.96	-	-	62	112	H
5	* 5.126	37.24	PK2	34	-26.7	44.54	-	-	74	-29.46	69	117	V
	* 5.126	26.58	MAv1	34	-26.7	33.88	54	-20.12	-	-	69	117	V
6	* 7.356	36.87	PK2	35.4	-26	46.27	-	-	74	-27.73	42	114	V
	* 7.356	26.14	MAv1	35.4	-26	35.54	54	-18.46	-	-	42	114	V

* - indicates frequency in CFR 47, Part 15 and Industry Canada RSS-Restricted Band.

PK2 - KDB558074 Method: Maximum Peak

MAv1 - KDB558074 Option 1 Maximum RMS Average

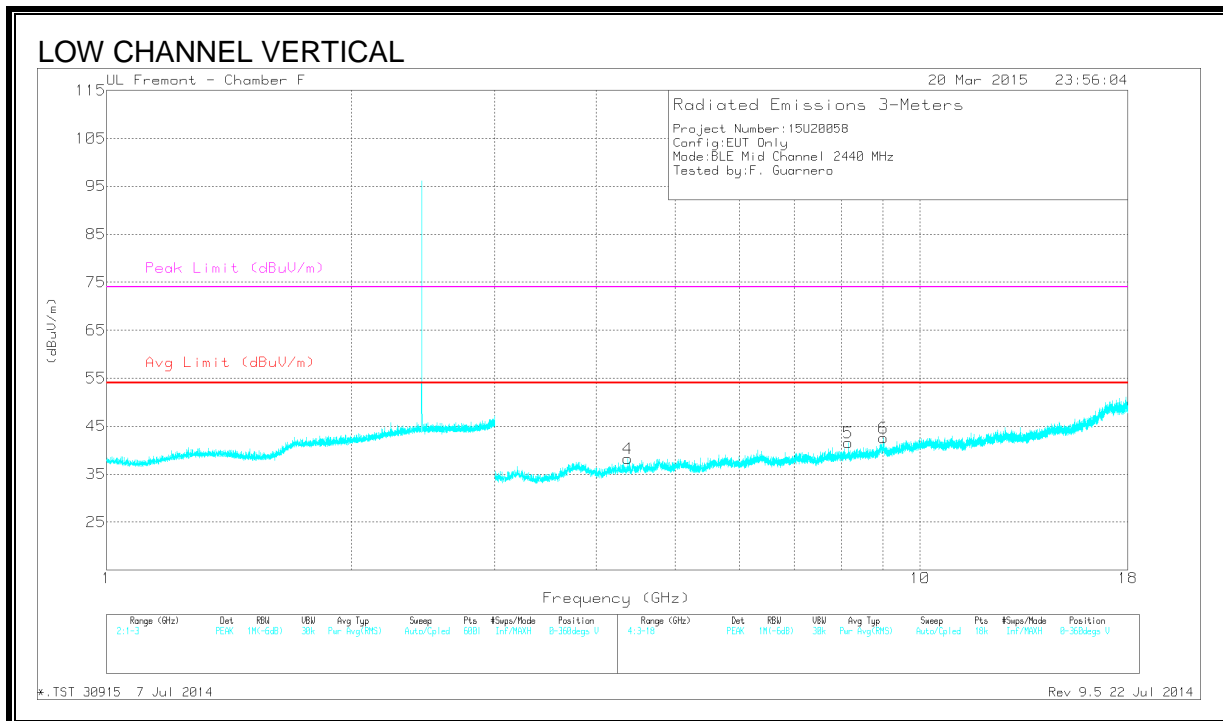
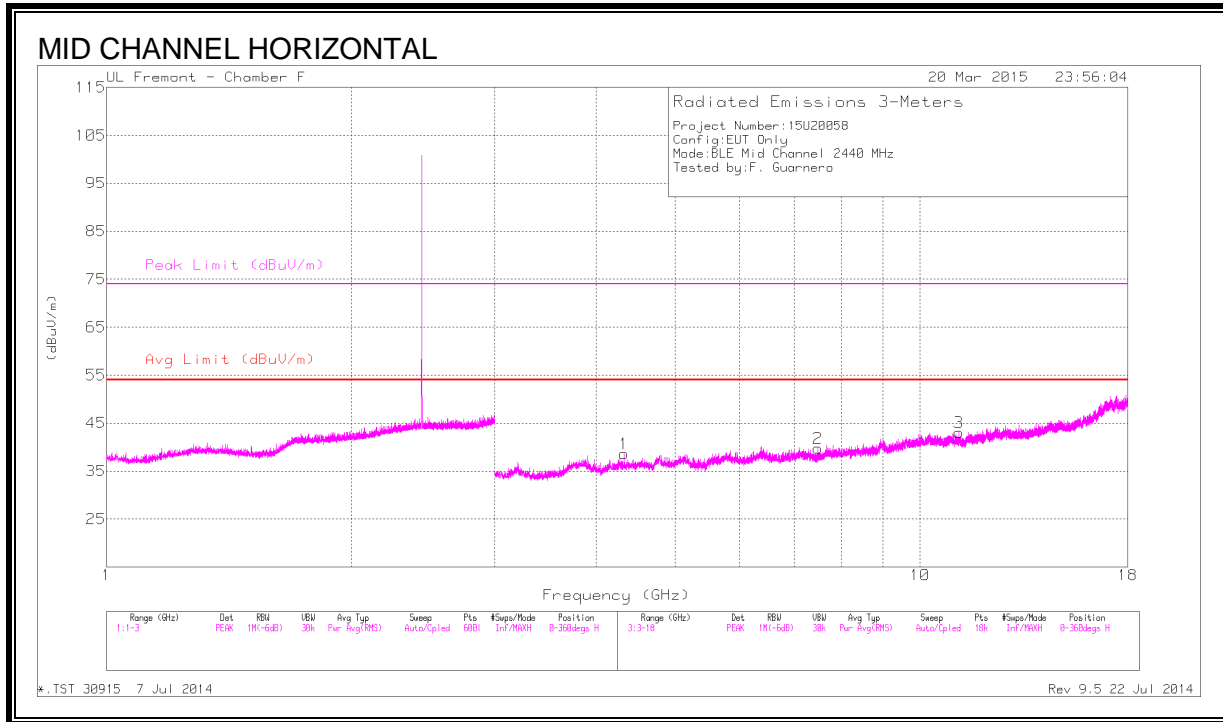

DATA

Marker	Frequency (GHz)	Meter Reading (dBuV)	Det	AF T712 (dB/m)	Amp/Cbl/ Fltr/Pad (db)	Corrected Reading (dBuV/m)	Avg Limit (dBuV/m)	Margin (dB)	Peak Limit (dBuV/m)	PK Margin (dB)	Azimuth (Degs)	Height (cm)	Polarity
1	* 4.326	39.04	PK2	33.4	-29.1	43.34	-	-	74	-30.66	173	226	H
	* 4.329	27.58	MAv1	33.4	-29	31.98	54	-22.02	-	-	173	226	H
2	* 7.479	36.82	PK2	35.4	-26.1	46.12	-	-	74	-27.88	167	211	H
	* 7.481	26.13	MAv1	35.4	-26.1	35.43	54	-18.57	-	-	167	211	H
3	* 11.161	33.84	PK2	37.4	-21.8	49.44	-	-	74	-24.56	195	225	H
	* 11.162	23.25	MAv1	37.4	-21.8	38.85	54	-15.15	-	-	195	225	H
4	* 4.37	39.34	PK2	33.5	-29	43.84	-	-	74	-30.16	206	345	V
	* 4.372	27.39	MAv1	33.5	-28.9	31.99	54	-22.01	-	-	206	345	V
5	* 8.162	35.82	PK2	35.8	-24.9	46.72	-	-	74	-27.28	216	337	V
	* 8.164	25.42	MAv1	35.8	-24.9	36.32	54	-17.68	-	-	216	337	V
6	* 9.021	34.26	PK2	36.2	-22.3	48.16	-	-	74	-25.84	174	317	V
	* 9.023	23.69	MAv1	36.2	-22.3	37.59	54	-16.41	-	-	174	317	V

* - indicates frequency in CFR 47, Part 15 and Industry Canada RSS-Restricted Band.

PK2 - KDB558074 Method: Maximum Peak

MAv1 - KDB558074 Option 1 Maximum RMS Average

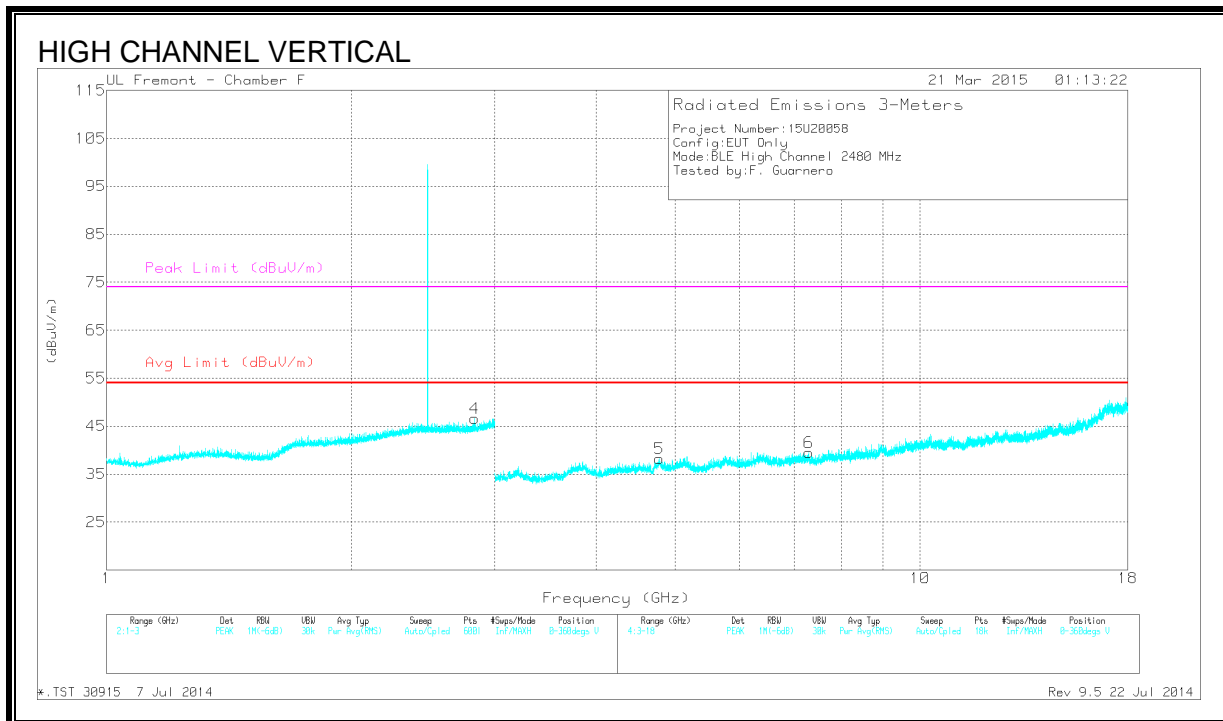
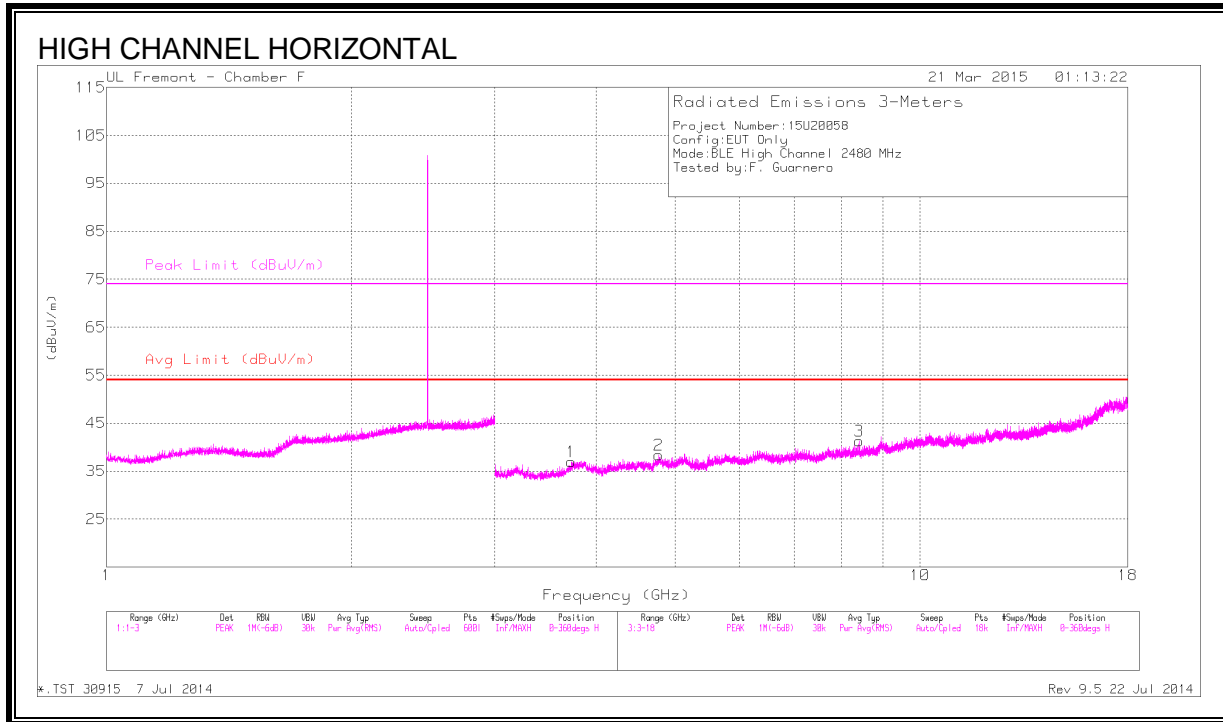

DATA

Marker	Frequency (GHz)	Meter Reading (dBuV)	Det	AF T712 (dB/m)	Amp/Cbl/Fltr/Pad (dB)	Corrected Reading (dBuV/m)	Avg Limit (dBuV/m)	Margin (dB)	Peak Limit (dBuV/m)	PK Margin (dB)	Azimuth (Degs)	Height (cm)	Polarity
1	* 3.723	39.61	PK2	33.1	-29.3	43.41	-	-	74	-30.59	105	173	H
	* 3.725	27.97	MAv1	33.1	-29.3	31.77	54	-22.23	-	-	105	173	H
3	* 8.413	35.45	PK2	35.8	-23.8	47.45	-	-	74	-26.55	104	169	H
	* 8.411	23.95	MAv1	35.8	-23.7	36.05	54	-17.95	-	-	104	169	H
2	* 4.775	38.15	PK2	34	-27.4	44.75	-	-	74	-29.25	98	174	H
	* 4.776	27.68	MAv1	33.9	-27.4	34.18	54	-19.82	-	-	98	174	H
4	* 2.836	41.51	PK2	32	-20.4	53.11	-	-	74	-20.89	4	174	V
	* 2.836	29.61	MAv1	32	-20.4	41.21	54	-12.79	-	-	4	174	V
5	* 4.776	38.49	PK2	33.9	-27.4	44.99	-	-	74	-29.01	19	182	V
	* 4.778	27.52	MAv1	33.9	-27.4	34.02	54	-19.98	-	-	19	182	V
6	* 7.3	37.87	PK2	35.4	-26.3	46.97	-	-	74	-27.03	10	192	V
	* 7.3	26.6	MAv1	35.4	-26.3	35.7	54	-18.3	-	-	10	192	V

* - indicates frequency in CFR 47, Part 15 and Industry Canada RSS-Restricted Band.

PK2 - KDB558074 Method: Maximum Peak

MAv1 - KDB558074 Option 1 Maximum RMS Average

8.3. WORST-CASE BELOW 1 GHz

SPURIOUS EMISSIONS 30 TO 1000 MHz (WORST-CASE CONFIGURATION)

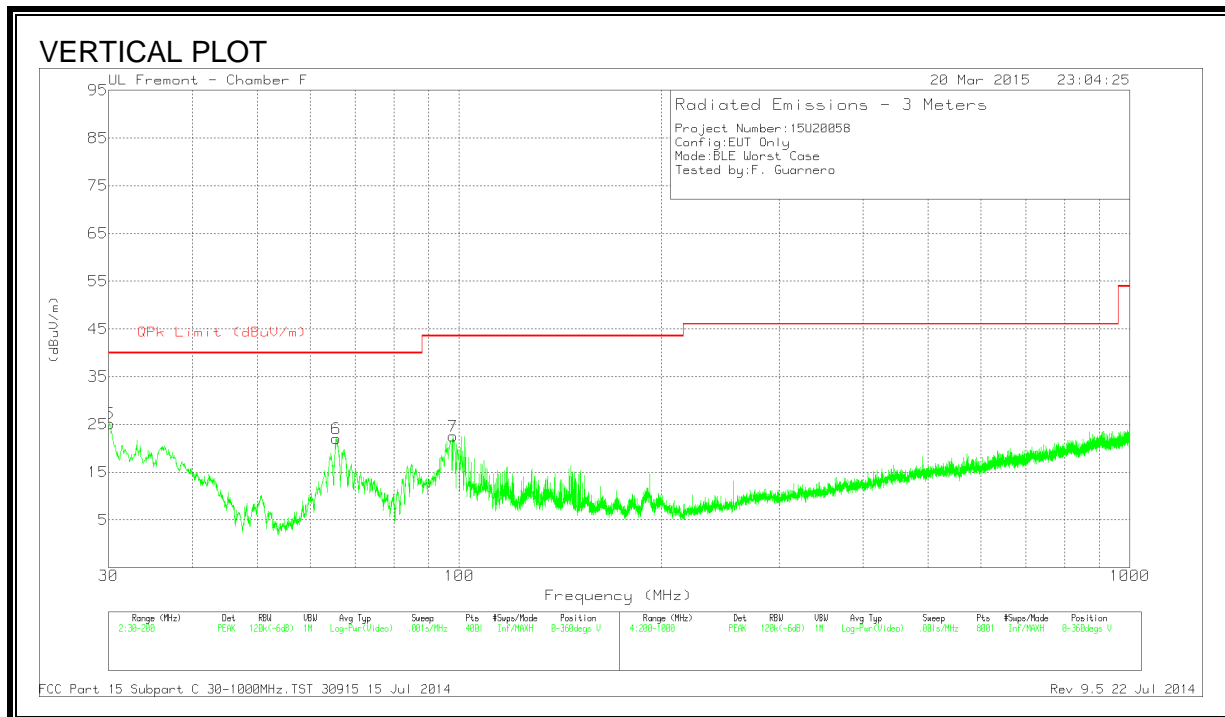
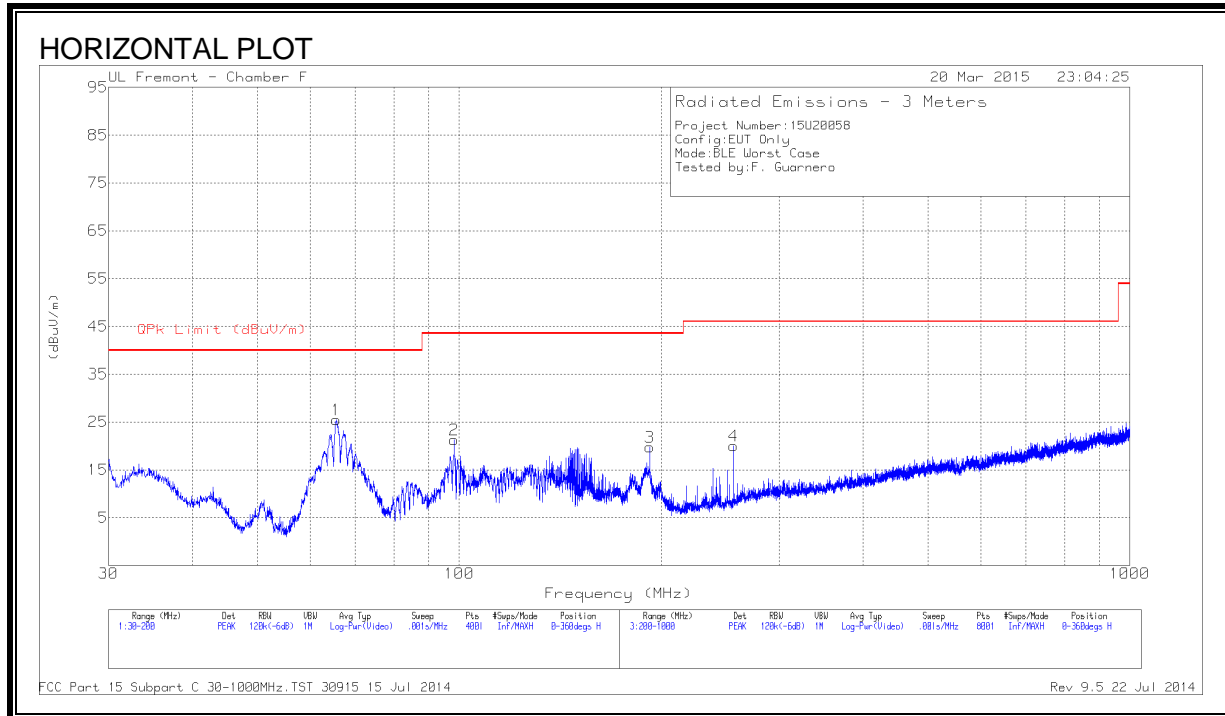

DATA

Marker	Frequency (MHz)	Meter Reading (dBuV)	Det	AF T122 (dB/m)	Amp/Cbl (dB)	Corrected Reading (dBuV/m)	QPk Limit (dBuV/m)	Margin (dB)	Azimuth (Degs)	Height (cm)	Polarity
1	65.615	48.99	PK	8	-31.5	25.49	40	-14.51	0-360	302	H
2	98.34	42.93	PK	9.7	-31.3	21.33	43.52	-22.19	0-360	302	H
3	192.3925	38.93	PK	11.4	-30.6	19.73	43.52	-23.79	0-360	103	H
5	30.1275	36.26	PK	20.8	-31.9	25.16	40	-14.84	0-360	100	V
6	65.53	45.58	PK	8	-31.5	22.08	40	-17.92	0-360	100	V
7	97.83	44.4	PK	9.5	-31.3	22.6	43.52	-20.92	0-360	100	V
4	* 256.5	38.57	PK	11.7	-30.3	19.97	46.02	-26.05	0-360	100	H

* - indicates frequency in CFR 47, Part 15 and Industry Canada RSS-Restricted Band.

PK - Peak detector

8.4. WORST-CASE 18 to 26 GHz

SPURIOUS EMISSIONS 18 to 26 GHz (WORST-CASE CONFIGURATION)

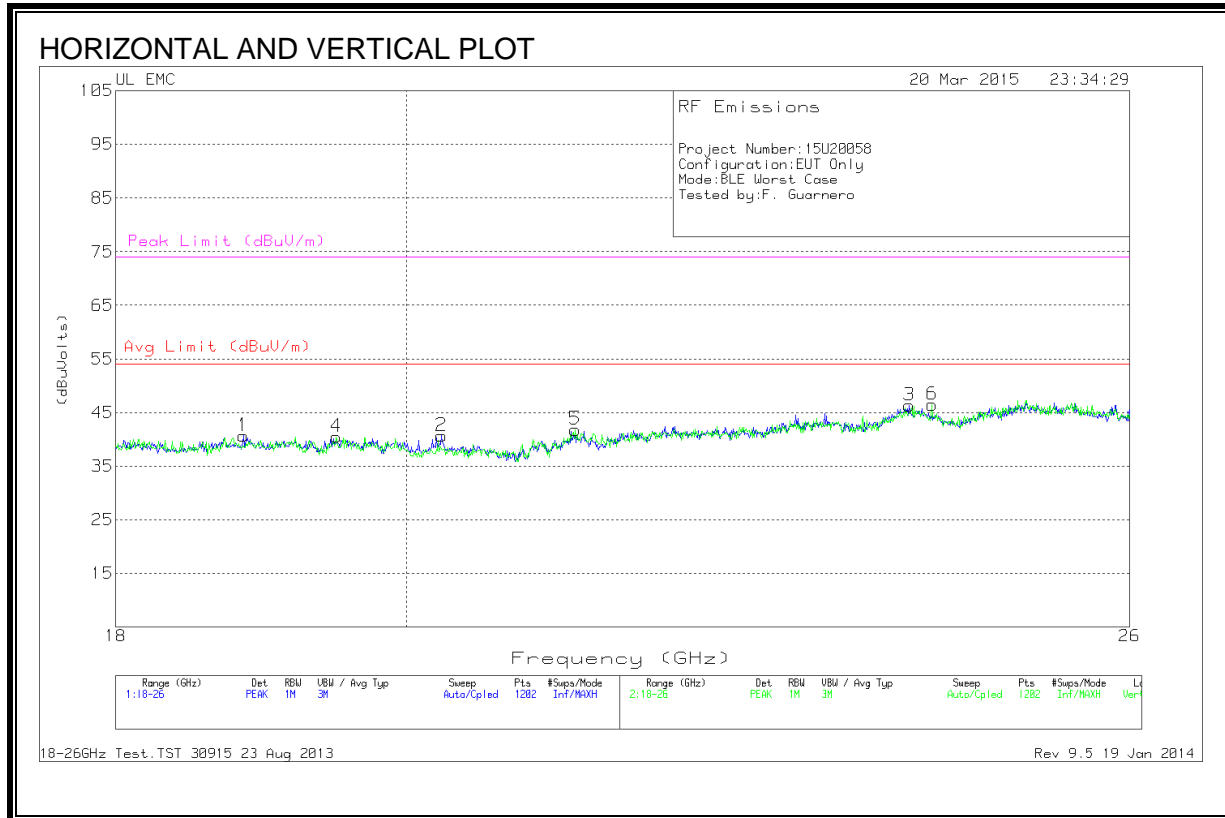

DATA

Marker	Frequency (GHz)	Meter Reading (dBuV)	Det	T89 AF (dB/m)	Amp/Cbl (dB)	Dist Corr (dB)	Corrected Reading (dBuVolts)	Avg Limit (dBuV/m)	Margin (dB)	Peak Limit (dBuV/m)	PK Margin (dB)
1	18.853	41.97	PK	32.8	-24.6	-9.5	40.67	54	-13.33	74	-33.33
2	20.258	41.07	PK	32.9	-23.8	-9.5	40.67	54	-13.33	74	-33.33
3	24.002	44.33	PK	34.2	-22.7	-9.5	46.33	54	-7.67	74	-27.67
4	19.499	41.5	PK	32.8	-24.3	-9.5	40.5	54	-13.5	74	-33.5
5	21.264	41.93	PK	33.3	-23.9	-9.5	41.83	54	-12.17	74	-32.17
6	24.201	44.7	PK	34.2	-22.9	-9.5	46.5	54	-7.5	74	-27.5

PK - Peak detector

9. AC POWER LINE CONDUCTED EMISSIONS

LIMITS

FCC §15.207 (a)

RSS-Gen 8.8

Frequency of Emission (MHz)	Conducted Limit (dBuV)	
	Quasi-peak	Average
0.15-0.5	66 to 56	56 to 46
0.5-5	56	46
5-30	60	50

*Decreases with the logarithm of the frequency.

TEST PROCEDURE

ANSI C63.10

RESULTS

LINE 1 RESULTS

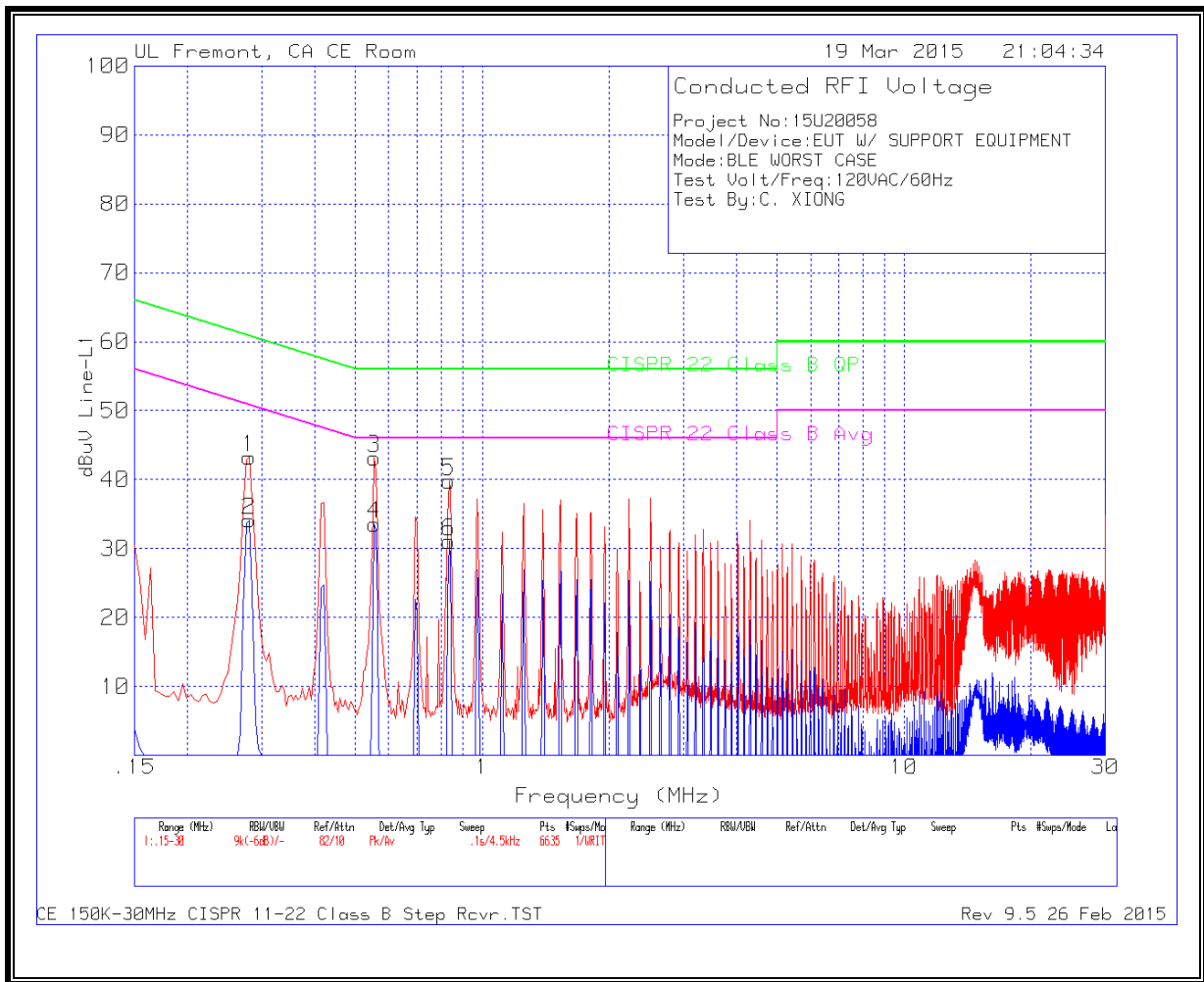

WORST EMISSIONS

Range 1: Line-L1 .15 - 30MHz

Marker	Frequency (MHz)	Meter Reading (dBuV)	Det	T24 IL L1	LC Cables 1&3	Corrected Reading dBuV	CISPR 22 Class B QP	Margin (dB)	CISPR 22 Class B Avg	Margin (dB)
1	.2805	42.64	Pk	.6	0	43.24	60.8	-17.56	50.8	-7.56
2	.2805	33.53	Av	.6	0	34.13	60.8	-26.67	50.8	-16.67
3	.555	42.84	Pk	.3	0	43.14	56	-12.86	46	-2.86
4	.555	33.27	Av	.3	0	33.57	56	-22.43	46	-12.43
5	.834	39.45	Pk	.3	0	39.75	56	-16.25	46	-6.25
6	.834	30.75	Av	.3	0	31.05	56	-24.95	46	-14.95

Pk - Peak detector

Av - Average detection

LINE 2 RESULTS

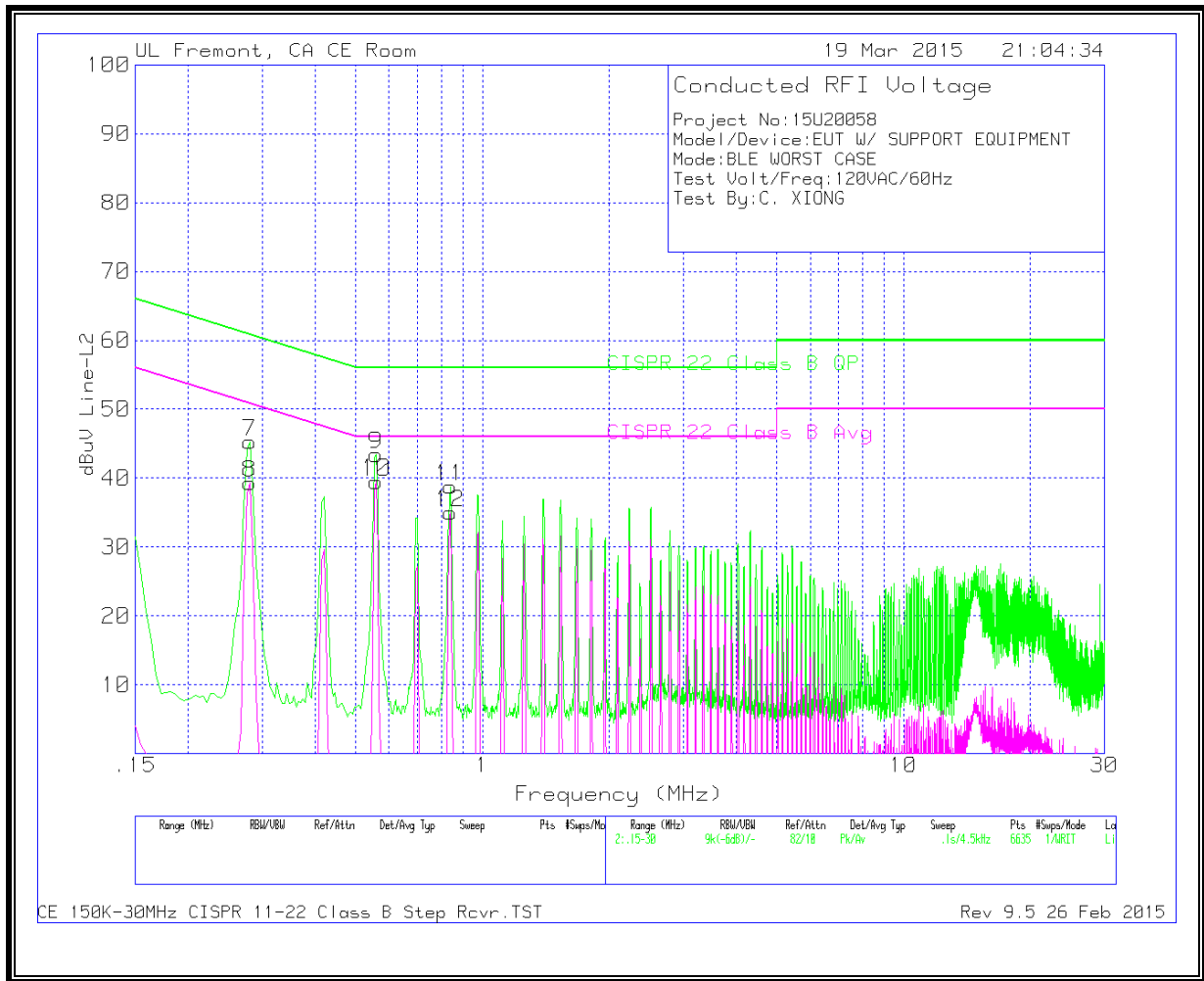

WORST EMISSIONS

Range 2: Line-L2 .15 - 30MHz

Marker	Frequency (MHz)	Meter Reading (dBuV)	Det	T24 IL L2	LC Cables 2&3	Corrected Reading dBuV	CISPR 22 Class B QP	Margin (dB)	CISPR 22 Class B Avg	Margin (dB)
7	.2805	44.68	Pk	.6	0	45.28	60.8	-15.52	50.8	-5.52
8	.2805	38.73	Av	.6	0	39.33	60.8	-21.47	50.8	-11.47
9	.5595	43.15	Pk	.3	0	43.45	56	-12.55	46	-2.55
10	.5595	39.18	Av	.3	0	39.48	56	-16.52	46	-6.52
11	.8385	38.38	Pk	.3	.1	38.78	56	-17.22	46	-7.22
12	.8385	34.61	Av	.3	.1	35.01	56	-20.99	46	-10.99

Pk - Peak detector

Av - Average detection