



**CC 47 CFR PART 15 SUBPART E
INDUSTRY CANADA RSS-210 ISSUE 8**

CERTIFICATION TEST REPORT

FOR

Tablet with IEEE 802.11a/b/g/n (MIMO 2x2) and Bluetooth Radio

MODEL NUMBER: A1474

FCC ID: BCGA1474

IC: 579C-A1474

REPORT NUMBER: 13U15555-2

ISSUE DATE: SEPTEMBER 17, 2013

Prepared for

**APPLE, INC.
1 INFINITE LOOP
CUPERTINO, CA 95014, U.S.A.**

Prepared by

**UL VERIFICATION SERVICES INC.
47173 BENICIA STREET
FREMONT, CA 94538, U.S.A.
TEL: (510) 771-1000
FAX: (510) 661-0888**



NVLAP LAB CODE 200065-0

Revision History

<u>Rev.</u>	<u>Issue Date</u>	<u>Revisions</u>	<u>Revised By</u>
--	09/17/13	Initial Issue	T. Chan

TABLE OF CONTENTS

1. ATTESTATION OF TEST RESULTS	7
2. TEST METHODOLOGY	8
3. FACILITIES AND ACCREDITATION	8
4. CALIBRATION AND UNCERTAINTY	8
4.1. <i>MEASURING INSTRUMENT CALIBRATION</i>	<i>8</i>
4.2. <i>SAMPLE CALCULATION</i>	<i>8</i>
4.3. <i>MEASUREMENT UNCERTAINTY.....</i>	<i>9</i>
5. EQUIPMENT UNDER TEST	9
5.1. <i>DESCRIPTION OF EUT</i>	<i>9</i>
5.2. <i>MAXIMUM OUTPUT POWER.....</i>	<i>9</i>
5.3. <i>DESCRIPTION OF AVAILABLE ANTENNAS</i>	<i>11</i>
5.4. <i>SOFTWARE AND FIRMWARE.....</i>	<i>11</i>
5.5. <i>WORST-CASE CONFIGURATION AND MODE.....</i>	<i>11</i>
5.6. <i>DESCRIPTION OF TEST SETUP.....</i>	<i>12</i>
6. TEST AND MEASUREMENT EQUIPMENT	15
7. ON TIME, DUTY CYCLE AND MEASUREMENT METHODS	16
7.1. <i>ON TIME AND DUTY CYCLE RESULTS.....</i>	<i>16</i>
7.2. <i>MEASUREMENT METHOD FOR POWER AND PPSD.....</i>	<i>16</i>
7.3. <i>MEASUREMENT METHOD FOR AVERAGE SPURIOUS EMISSIONS ABOVE 1 GHz</i> 16	
7.4. <i>DUTY CYCLE PLOTS</i>	<i>17</i>
8. ANTENNA PORT TEST RESULTS	19
8.1. <i>802.11a SISO MODE IN THE 5.2 GHz BAND</i>	<i>19</i>
8.1.1. <i>26 dB BANDWIDTH.....</i>	<i>19</i>
8.1.2. <i>99% BANDWIDTH.....</i>	<i>22</i>
8.1.3. <i>AVERAGE POWER.....</i>	<i>25</i>
8.1.4. <i>OUTPUT POWER AND PSD</i>	<i>26</i>
8.2. <i>802.11n HT20 2TX CDD MODE IN THE 5.2 GHz BAND</i>	<i>30</i>
8.2.1. <i>26 dB BANDWIDTH.....</i>	<i>30</i>
8.2.2. <i>99% BANDWIDTH.....</i>	<i>34</i>
8.2.3. <i>AVERAGE POWER</i>	<i>38</i>
8.2.4. <i>OUTPUT POWER AND PPSD</i>	<i>39</i>
8.3. <i>802.11n HT20 2TX STBC MODE IN THE 5.2 GHz BAND</i>	<i>44</i>
8.3.1. <i>26 dB BANDWIDTH.....</i>	<i>44</i>
8.3.2. <i>99% BANDWIDTH.....</i>	<i>48</i>
8.3.3. <i>AVERAGE POWER</i>	<i>52</i>

8.3.4. OUTPUT POWER AND PPSD53

8.4. 802.11n HT40 SISO MODE IN THE 5.2 GHz BAND.....58

8.4.1. 26 dB BANDWIDTH.....58

8.4.2. 99% BANDWIDTH.....60

8.4.3. AVERAGE POWER.....62

8.4.4. OUTPUT POWER AND PPSD63

8.5. 802.11n HT40 2TX CDD MODE IN THE 5.2 GHz BAND66

8.5.1. 26 dB BANDWIDTH.....66

8.5.2. 99% BANDWIDTH.....69

8.5.3. AVERAGE POWER.....72

8.5.4. OUTPUT POWER AND PPSD73

8.6. 802.11n HT40 2TX STBC MODE IN THE 5.2 GHz BAND77

8.6.1. 26 dB BANDWIDTH.....77

8.6.2. 99% BANDWIDTH.....79

8.6.3. AVERAGE POWER.....81

8.6.4. OUTPUT POWER AND PPSD82

8.7. 802.11a SISO MODE IN THE 5.3 GHz BAND85

8.7.1. 26 dB BANDWIDTH.....85

8.7.2. 99% BANDWIDTH.....88

8.7.3. AVERAGE POWER.....91

8.7.4. OUTPUT POWER AND PPSD92

8.7.5. PEAK EXCURSION.....96

8.8. 802.11n HT20 CDD MODE IN THE 5.3 GHz BAND.....98

8.8.1. 26 dB BANDWIDTH.....98

8.8.2. 99% BANDWIDTH.....102

8.8.3. AVERAGE POWER.....106

8.8.4. OUTPUT POWER AND PPSD107

8.8.5. PEAK EXCURSION.....112

8.9. 802.11n HT40 SISO MODE IN THE 5.3 GHz BAND..... 115

8.9.1. 26 dB BANDWIDTH.....115

8.9.2. 99% BANDWIDTH.....117

8.9.3. AVERAGE POWER.....119

8.9.4. OUTPUT POWER AND PPSD120

8.9.5. PEAK EXCURSION.....123

8.10. 802.11n HT40 2TX CDD MODE IN THE 5.3 GHz BAND..... 125

8.10.1. 26 dB BANDWIDTH.....125

8.10.2. 99% BANDWIDTH.....128

8.10.3. AVERAGE POWER.....131

8.10.4. OUTPUT POWER AND PPSD132

8.10.5. PEAK EXCURSION.....136

8.11. 802.11a SISO MODE IN THE 5.6 GHz BAND 138

8.11.1. 26 dB BANDWIDTH.....138

8.11.2. 99% BANDWIDTH.....141

8.11.3. AVERAGE POWER.....144

8.11.4. OUTPUT POWER AND PPSD145

8.11.5. PEAK EXCURSION.....149

8.12. 802.11n HT20 2TX CDD MODE IN THE 5.6 GHz BAND..... 151

8.12.1. 26 dB BANDWIDTH.....151

- 8.12.2. 99% BANDWIDTH.....155
- 8.12.3. AVERAGE POWER.....159
- 8.12.4. OUTPUT POWER AND PPSD160
- 8.12.5. PEAK EXCURSION.....165
- 8.13. 802.11n HT20 2TX STBC MODE IN THE 5.6 GHz BAND.....168
 - 8.13.1. 26 dB BANDWIDTH.....168
 - 8.13.2. 99% BANDWIDTH.....170
 - 8.13.3. AVERAGE POWER.....172
 - 8.13.4. OUTPUT POWER AND PPSD173
 - 8.13.5. PEAK EXCURSION.....176
- 8.14. 802.11n HT40 SISO MODE IN THE 5.6 GHz BAND178
 - 8.14.1. 26 dB BANDWIDTH.....178
 - 8.14.2. 99% BANDWIDTH.....181
 - 8.14.3. AVERAGE POWER.....184
 - 8.14.4. OUTPUT POWER AND PPSD185
 - 8.14.5. PEAK EXCURSION.....189
- 8.15. 802.11n HT40 2TX CDD MODE IN THE 5.6 GHz BAND.....191
 - 8.15.1. 26 dB BANDWIDTH.....191
 - 8.15.2. 99% BANDWIDTH.....195
 - 8.15.3. AVERAGE POWER.....199
 - 8.15.4. OUTPUT POWER AND PPSD200
 - 8.15.5. PEAK EXCURSION.....205
- 9. RADIATED TEST RESULTS.....207**
 - 9.1. LIMITS AND PROCEDURE.....207
 - 9.2. TRANSMITTER ABOVE 1 GHz.....208
 - 9.2.1. 802.11a SISO MODE IN THE 5.2 GHz BAND208
 - 9.2.2. 802.11n HT20 2TX CDD MODE IN THE 5.2 GHz BAND216
 - 9.2.3. 802.11n HT20 2TX STBC MODE IN THE 5.2 GHz BAND221
 - 9.2.4. 802.11n HT40 SISO MODE IN THE 5.2 GHz BAND.....222
 - 9.2.5. 802.11n HT40 2TX CDD MODE IN THE 5.2 GHz BAND228
 - 9.2.6. 802.11n HT40 2TX STBC MODE IN THE 5.2 GHz BAND233
 - 9.2.7. 802.11a SISO MODE IN THE 5.3 GHz BAND234
 - 9.2.8. 802.11n HT20 2TX CDD MODE IN THE 5.3 GHz BAND242
 - 9.2.9. 802.11n HT40 SISO MODE IN THE 5.3 GHz BAND.....247
 - 9.2.10. 802.11n HT40 2TX CDD MODE IN THE 5.3 GHz BAND253
 - 9.2.11. 802.11a SISO MODE IN THE 5.6 GHz BAND257
 - 9.2.12. 802.11n HT20 2TX CDD MODE IN THE 5.6 GHz BAND266
 - 9.2.13. 802.11n HT20 2TX STBC MODE IN THE 5.6 GHz BAND272
 - 9.2.14. 802.11n HT40 SISO MODE IN THE 5.6 GHz BAND.....273
 - 9.2.15. 802.11n HT40 2TX MODE IN THE 5.6 GHz BAND.....282
 - 9.2.16. WORST-CASE 2.4GHZ & 5GHZ BAND CO-LOCATION289
 - 9.3. WORST-CASE ABOVE 18 GHz292
 - 9.4. WORST-CASE BELOW 1 GHz.....298
- 10. AC POWER LINE CONDUCTED EMISSIONS300**
- 11. DYNAMIC FREQUENCY SELECTION305**
 - 11.1. OVERVIEW.....305

- 11.1.1. LIMITS.....305
- 11.1.2. TEST AND MEASUREMENT SYSTEM.....308
- 11.1.3. SETUP OF EUT.....311
- 11.1.4. SETUP OF EUT (CLIENT-TO-CLIENT COMMUNICATIONS MODE).....312
- 11.1.5. DESCRIPTION OF EUT313
- 11.2. RESULTS FOR 20 MHz BANDWIDTH.....315
 - 11.2.1. TEST CHANNEL315
 - 11.2.2. RADAR WAVEFORM AND TRAFFIC.....315
 - 11.2.3. OVERLAPPING CHANNEL TESTS.....317
 - 11.2.4. MOVE AND CLOSING TIME317
- 11.3. RESULTS FOR 40 MHz BANDWIDTH.....322
 - 11.3.1. TEST CHANNEL322
 - 11.3.2. RADAR WAVEFORM AND TRAFFIC.....322
 - 11.3.3. OVERLAPPING CHANNEL TESTS.....324
 - 11.3.4. MOVE AND CLOSING TIME324
 - 11.3.5. NON-OCCUPANCY PERIOD329
- 11.4. CLIENT-TO-CLIENT COMMUNICATIONS MODE RESULTS FOR 20 MHz BANDWIDTH.....330
 - 11.4.1. TEST CHANNEL330
 - 11.4.2. RADAR WAVEFORM AND TRAFFIC.....330
 - 11.4.3. OVERLAPPING CHANNEL TESTS.....332
 - 11.4.4. MOVE AND CLOSING TIME332
- 11.5. CLIENT-TO-CLIENT COMMUNICATIONS MODE RESULTS FOR 40 MHz BANDWIDTH.....337
 - 11.5.1. TEST CHANNEL337
 - 11.5.2. RADAR WAVEFORM AND TRAFFIC.....337
 - 11.5.3. OVERLAPPING CHANNEL TESTS.....339
 - 11.5.4. MOVE AND CLOSING TIME339
- 12. SETUP PHOTOS344**

1. ATTESTATION OF TEST RESULTS

COMPANY NAME: APPLE, INC.
1 INFINITE LOOP
CUPERTINO, CA 95014, U.S.A.

EUT DESCRIPTION: Tablet with IEEE 802.11a/b/g/n (MIMO 2x2) and Bluetooth radio

MODEL: A1474

SERIAL NUMBER: DLXKW04QFMN4 (Radiated), DLXKW02NFMN6 (Conducted)

DATE TESTED: JULY 9 - SEPTEMBER 16, 2013

APPLICABLE STANDARDS	
STANDARD	TEST RESULTS
CFR 47 Part 15 Subpart E	Pass
INDUSTRY CANADA RSS-210 Issue 8 Annex 9	Pass
INDUSTRY CANADA RSS-GEN Issue 3	Pass

UL Verification Services Inc. tested the above equipment in accordance with the requirements set forth in the above standards. All indications of Pass/Fail in this report are opinions expressed by UL Verification Services Inc. based on interpretations and/or observations of test results. Measurement Uncertainties were not taken into account and are published for informational purposes only. The test results show that the equipment tested is capable of demonstrating compliance with the requirements as documented in this report.

Note: The results documented in this report apply only to the tested sample, under the conditions and modes of operation as described herein. This document may not be altered or revised in any way unless done so by UL Verification Services Inc. and all revisions are duly noted in the revisions section. Any alteration of this document not carried out by UL Verification Services Inc. will constitute fraud and shall nullify the document. This report must not be used by the client to claim product certification, approval, or endorsement by NVLAP, NIST, any agency of the Federal Government, or any agency of any government.

Approved & Released For
UL Verification Services Inc. By:

Tested By:



Thu Chan
WiSE Operations Manager
UL Verification Services Inc.

Francisco Guarnero
WiSE Technician
UL Verification Services Inc.

2. TEST METHODOLOGY

The tests documented in this report were performed in accordance with FCC CFR 47 Part 2, FCC CFR 47 Part 15, FCC 06-96, FCC KDB 789033, ANSI C63.10-2009, RSS-GEN Issue 3, and RSS-210 Issue 8.

3. FACILITIES AND ACCREDITATION

The test sites and measurement facilities used to collect data are located at 47173 Benicia Street, Fremont, California, USA.

The test sites and measurement facilities used to collect data are located at 47173 and 47266 Benicia Street, Fremont, California, USA. Line conducted emissions are measured only at the 47173 address. The following table identifies which facilities were utilized for radiated emission measurements documented in this report. Specific facilities are also identified in the test results sections.

47173 Benicia Street	47266 Benicia Street
<input type="checkbox"/> Chamber A	<input type="checkbox"/> Chamber D
<input type="checkbox"/> Chamber B	<input checked="" type="checkbox"/> Chamber E
<input type="checkbox"/> Chamber C	<input checked="" type="checkbox"/> Chamber F

UL Verification Services Inc. is accredited by NVLAP, Laboratory Code 200065-0. The full scope of accreditation can be viewed at <http://www.ccsemc.com>.

4. CALIBRATION AND UNCERTAINTY

4.1. MEASURING INSTRUMENT CALIBRATION

The measuring equipment utilized to perform the tests documented in this report has been calibrated in accordance with the manufacturer's recommendations, and is traceable to recognized national standards.

4.2. SAMPLE CALCULATION

Where relevant, the following sample calculation is provided:

$$\begin{aligned} \text{Field Strength (dBuV/m)} &= \text{Measured Voltage (dBuV)} + \text{Antenna Factor (dB/m)} + \\ &\text{Cable Loss (dB)} - \text{Preamp Gain (dB)} \\ 36.5 \text{ dBuV} + 18.7 \text{ dB/m} + 0.6 \text{ dB} - 26.9 \text{ dB} &= 28.9 \text{ dBuV/m} \end{aligned}$$

4.3. MEASUREMENT UNCERTAINTY

Where relevant, the following measurement uncertainty levels have been estimated for tests performed on the apparatus:

PARAMETER	UNCERTAINTY
Conducted Disturbance, 0.15 to 30 MHz	3.52 dB
Radiated Disturbance, 30 to 1000 MHz	4.94 dB

Uncertainty figures are valid to a confidence level of 95%.

5. EQUIPMENT UNDER TEST

5.1. DESCRIPTION OF EUT

Tablet with IEEE 802.11a/b/g/n (MIMO 2x2) and Bluetooth radio

5.2. MAXIMUM OUTPUT POWER

The transmitter has a maximum conducted output power as follows:

Frequency Range (MHz)	Mode	Output Power (dBm)	Output Power (mW)
5180 - 5240	802.11a SISO	14.08	25.59
5180 - 5240	802.11n HT20 2Tx CDD	13.72	23.55
5180 - 5240	802.11n HT20 2Tx STBC	14.16	26.06
5190 - 5230	802.11n HT40 SISO	15.54	35.81
5190 - 5230	802.11n HT40 2Tx CDD	16.07	40.46
5190 - 5230	802.11n HT40 2Tx STBC	16.57	45.39
5260 - 5320	802.11a SISO	16.53	44.98
5260 - 5320	802.11n HT20 2Tx CDD	19.76	94.62
5270 - 5310	802.11n HT40 SISO	16.60	45.71
5270 - 5310	802.11n HT40 2Tx CDD	19.69	93.11
5500 - 5700	802.11a SISO	16.67	46.45
5500 - 5700	802.11n HT20 2Tx CDD	19.14	82.04
5500 - 5700	802.11n HT20 2Tx STBC	19.55	90.16
5510 - 5670	802.11n HT40 SISO	16.71	46.88
5510 - 5670	802.11n HT40 2Tx CDD	19.65	92.26

List of test reduction and modes covering other modes:

Antenna Port Testing		
Frequency Range (MHz)	Mode	Covered by
5.2 GHz band, 1TX		
5180 - 5240	802.11n SISO	802.11a SISO
5.2 GHz band, 2TX		
5180 - 5240	802.11a 2TX CDD	802.11n HT20 CDD 2TX
5190 - 5230	802.11n HT40 2TX STBC/SDM (Low Channel)	802.11n HT40 CDD 2TX
5.3 GHz band, SISO		
5260 - 5320	802.11n SISO	802.11a SISO
5.3 GHz band, 2TX		
5260 - 5320	802.11a 2TX CDD	802.11n HT20 CDD 2TX
5260 - 5320	802.11n HT20 2TX STBC/SDM	802.11n HT20 CDD 2TX
5270 - 5310	802.11n HT40 2TX STBC/SDM	802.11n HT40 CDD 2TX
5.6GHz Band 2TX		
5500 - 5700	802.11a 2TX CDD	802.11n HT20 CDD 2TX
5500 - 5700	802.11n SISO	802.11a SISO
5500 - 5700	802.11n HT20 2TX STBC/SDM (Low and High Ch)	802.11n HT20 CDD 2TX
5510 - 5670	802.11n HT40 2TX STBC/SDM	802.11n HT40 CDD 2TX

Radiated Testing		
Frequency Range (MHz)	Mode	Covered by
5.2 GHz band, 1TX		
5180 - 5240	802.11n SISO	802.11a SISO
5.2 GHz band, 2TX		
5180 - 5240	802.11a 2TX CDD	802.11n HT20 CDD 2TX
5180 - 5240	802.11n HT20 2TX STBC/SDM	802.11n HT20 CDD 2TX
5190 - 5230	802.11n HT40 2TX STBC/SDM	802.11n HT40 CDD 2TX
5.3 GHz band, SISO		
5260 - 5320	802.11n SISO	802.11a SISO
5.3 GHz band, 2TX		
5260 - 5320	802.11a 2TX CDD	802.11n HT20 CDD 2TX
5260 - 5320	802.11n HT20 2TX STBC/SDM	802.11n HT20 CDD 2TX
5270 - 5310	802.11n HT40 2TX STBC/SDM	802.11n HT40 CDD 2TX
5.6GHz Band 2TX		
5500 - 5700	802.11a 2TX CDD	802.11n HT20 CDD 2TX
5500 - 5700	802.11n SISO	802.11a SISO
5500 - 5700	802.11n HT20 2TX STBC/SDM	802.11n HT20 CDD 2TX
5510 - 5670	802.11n HT40 2TX STBC/SDM	802.11n HT40 CDD 2TX

5.3. DESCRIPTION OF AVAILABLE ANTENNAS

Frequency Band (GHz)	Antenna Gain		Uncorrelated Gain	Correlated Gain
	Tx1	Tx2		
2.4	0.50	1.99	1.31	4.32
5.2	2.37	2.07	2.22	5.23
5.3	2.60	2.11	2.36	5.37
5.5	3.66	3.99	3.83	6.84
5.8	4.21	3.92	4.07	7.08

5.4. SOFTWARE AND FIRMWARE

The test utility software used during testing was Broadcom WL Tool Version 6.25.86.

5.5. WORST-CASE CONFIGURATION AND MODE

The fundamental of the EUT was investigated in three orthogonal orientations X,Y,Z, it was determined that Z orientation was worst-case orientation for 5GHz; therefore, all final radiated testing was performed with the EUT in Z orientation for 5GHz.

Worst-case data rates as provided by the client were:

802.11a mode: 6 Mbps
802.11n HT20mode: MCS0
802.11n HT40mode: MCS0

Worst-case mode and channel used for 30-1000 MHz radiated and power line conducted emissions was including headset, AC charger and the mode and channel with the highest output power.

For all modes with single chain, chain 0 was selected per the software provided by the client. Based on the client a preliminary investigation was performed on the two chains and chain 0 was found to be worst-case for the antenna port. The radiated emissions test was based on the port with the higher antenna gain.

5.6. DESCRIPTION OF TEST SETUP

SUPPORT EQUIPMENT

Support Equipment List				
Description	Manufacturer	Model	Serial Number	FCC ID
AC/DC adapter	Apple	A1401	60812	NA
Earphone	Apple	NA	NA	NA

I/O CABLES (CONDUCTED TEST)

I/O Cable List						
Cable No	Port	# of identical ports	Connector Type	Cable Type	Cable Length (m)	Remarks
1	Antenna	1	SMA	Un-Shielded	0.1m	To Spectrum Analyzer

I/O CABLES (RADIATED TEST)

I/O Cable List						
Cable No	Port	# of identical ports	Connector Type	Cable Type	Cable Length (m)	Remarks
1	Audio	1	Jack	Un-Shielded	0.5m	NA

I/O CABLES (AC POWER CONDUCTED TEST)

I/O Cable List						
Cable No	Port	# of identical ports	Connector Type	Cable Type	Cable Length (m)	Remarks
1	AC	1	US115	Un-Shielded	2m	NA
2	DC	1	USB	Un-Shielded	2m	NA
3	Audio	1	Jack	Un-Shielded	0.5m	NA

SETUP DIAGRAM FOR CONDUCTED TESTS

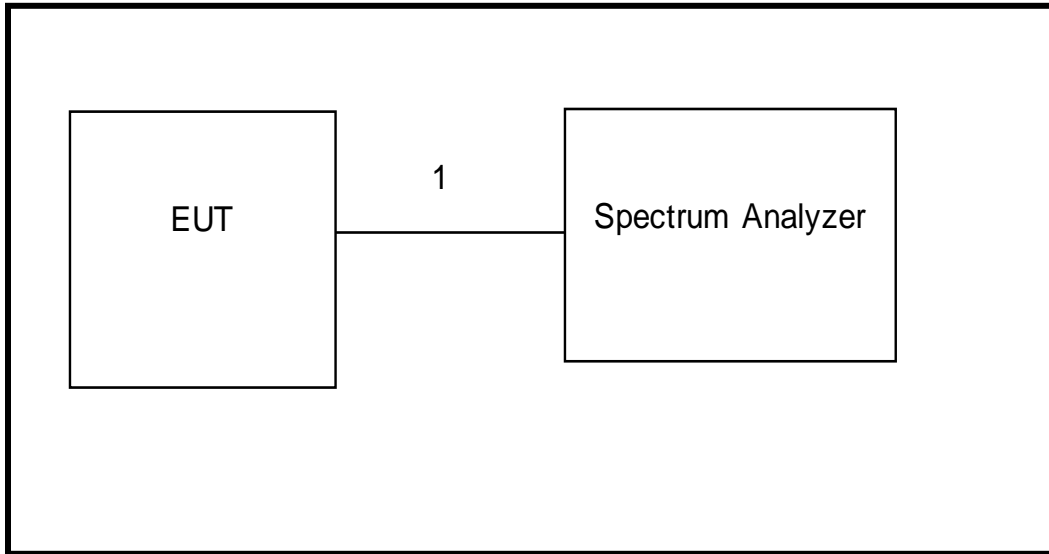

SETUP DIAGRAM FOR RADIATED TESTS

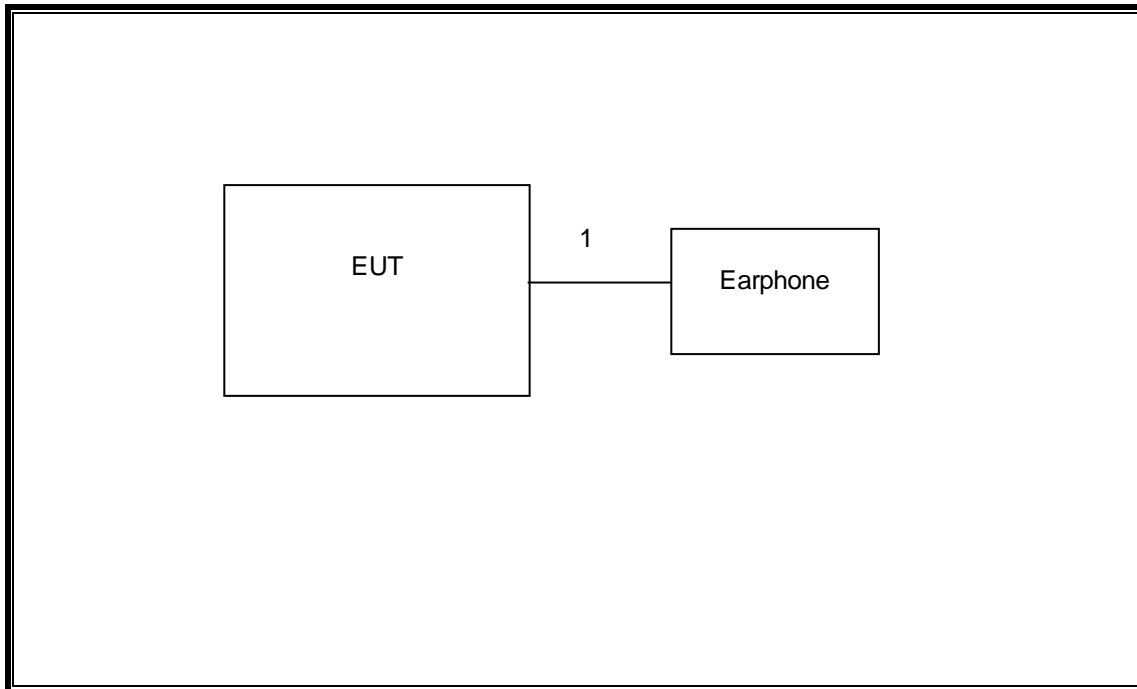

SETUP DIAGRAM FOR BELOW 1GHZ & AC POWER CONDUCTED TESTS

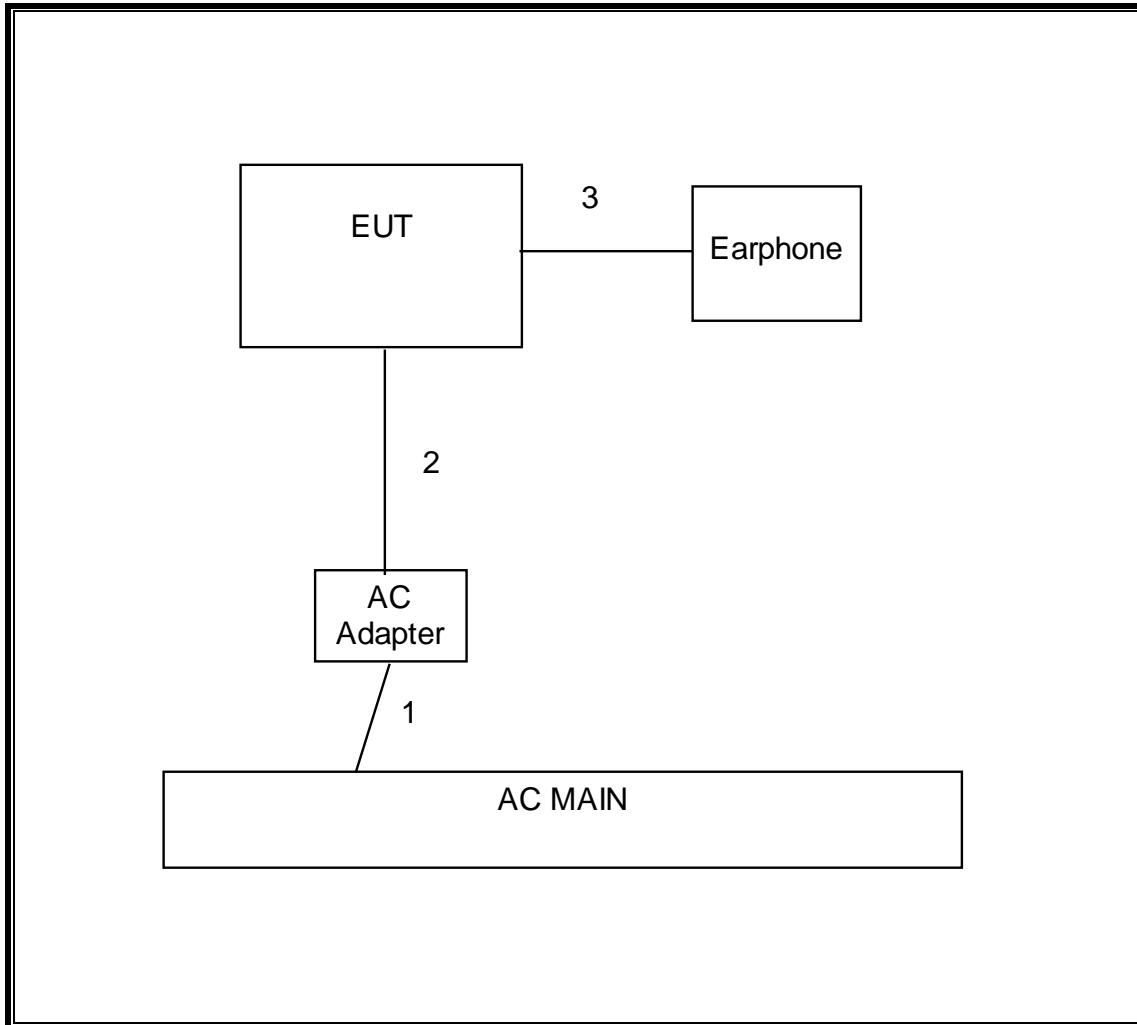

6. TEST AND MEASUREMENT EQUIPMENT

The following test and measurement equipment was utilized for the tests documented in this report:

Test Equipment List				
Description	Manufacturer	Model	Asset	Cal Due
Horn Antenna 1-18GHz	ETS Lindgren	3117	F00131	02/19/14
Preamplifier, 1300 MHz	Agilent / HP	8447D	C00580	01/28/14
Antenna, Horn, 26.5 GHz	ARA	SWH-28	C01015	05/06/14
Antenna, Biconolog, 30MHz-1 GHz	Sunol Sciences	JB3	F00027	03/07/14
Peak / Average Power Sensor	Agilent / HP	E9323A	F00163	04/03/14
P-Series single channel Power Meter	Agilent / HP	N1911A	F00164	04/03/14
Spectrum Analyzer, 3Hz-44GHz	Agilent	N9030A	F00127	02/22/14
Spectrum Analyzer, 3Hz-44GHz	Agilent	E4446A	C01012	10/21/13
PreApmplifier, 1-26.5GHz	Agilent	8449B	C01052	10/22/13
Antenna, Horn, 40 GHz	ARA	MWH-2640/B	F00194	05/14/14
EMI Test Receiver, 30 MHz	R & S	ESHS 20	N02396	08/15/14
Preamplifier, 40 GHz	Miteq	NSP4000-SP2	C00990	08/20/14

7. ON TIME, DUTY CYCLE AND MEASUREMENT METHODS

LIMITS

None; for reporting purposes only.

PROCEDURE

KDB 789033 Zero-Span Spectrum Analyzer Method.

7.1. ON TIME AND DUTY CYCLE RESULTS

Mode	ON Time B (msec)	Period (msec)	Duty Cycle x (linear)	Duty Cycle (%)	Duty Cycle Correction Factor (dB)	1/T Minimum VBW (kHz)
802.11a 20 MHz	2.06	2.08	0.992	99.2%	0.00	0.010
802.11n HT20	1.91	1.94	0.986	98.6%	0.00	0.010
802.11n HT40	0.93	0.95	0.981	98.1%	0.00	0.010

7.2. MEASUREMENT METHOD FOR POWER AND PPSD

The Duty Cycle is greater than or equal to 98% therefore KDB 789033 Method SA-1 is used.

The Duty Cycle is greater than or equal to 98% therefore KDB 789033 Method SA-1 Alternative is used.

7.3. MEASUREMENT METHOD FOR AVERAGE SPURIOUS EMISSIONS ABOVE 1 GHz

The Duty Cycle is greater than or equal to 98%, KDB 789033 Method AD with Power RMS Averaging is used.

7.4. DUTY CYCLE PLOTS

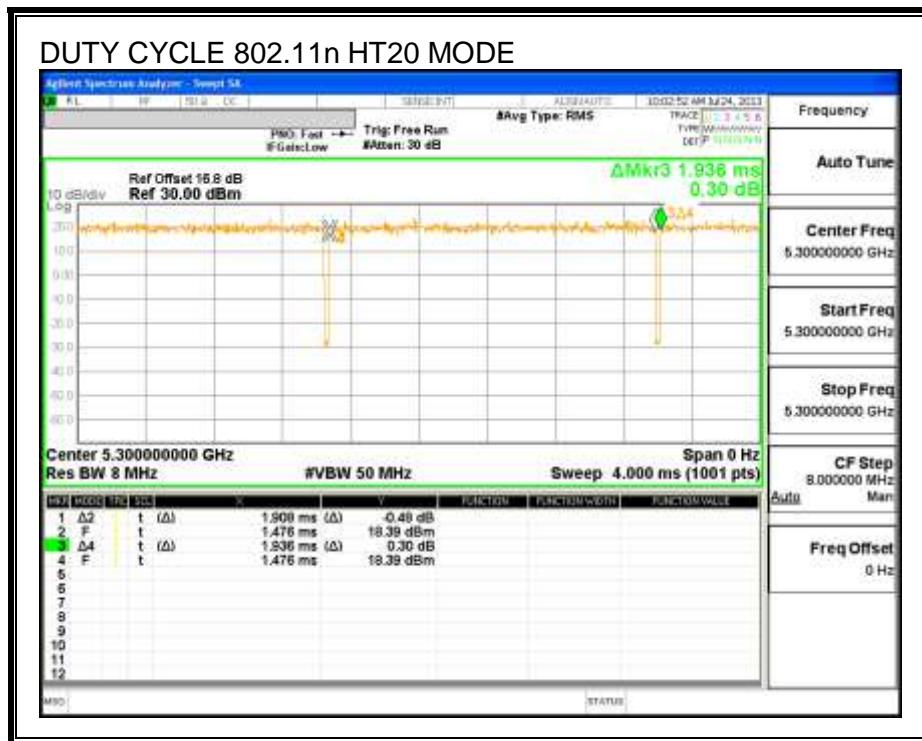
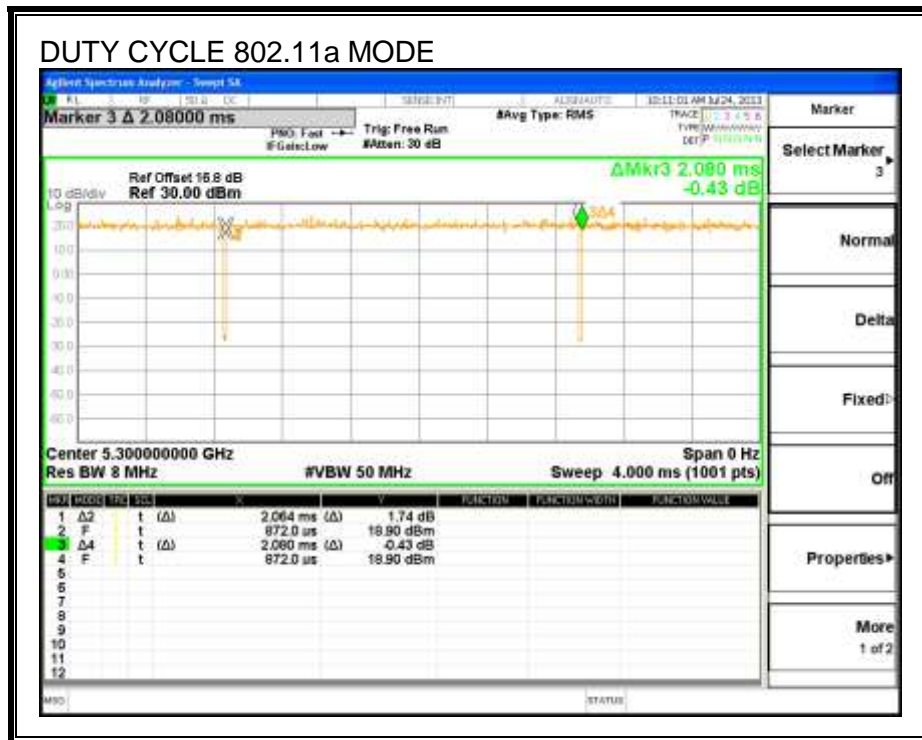

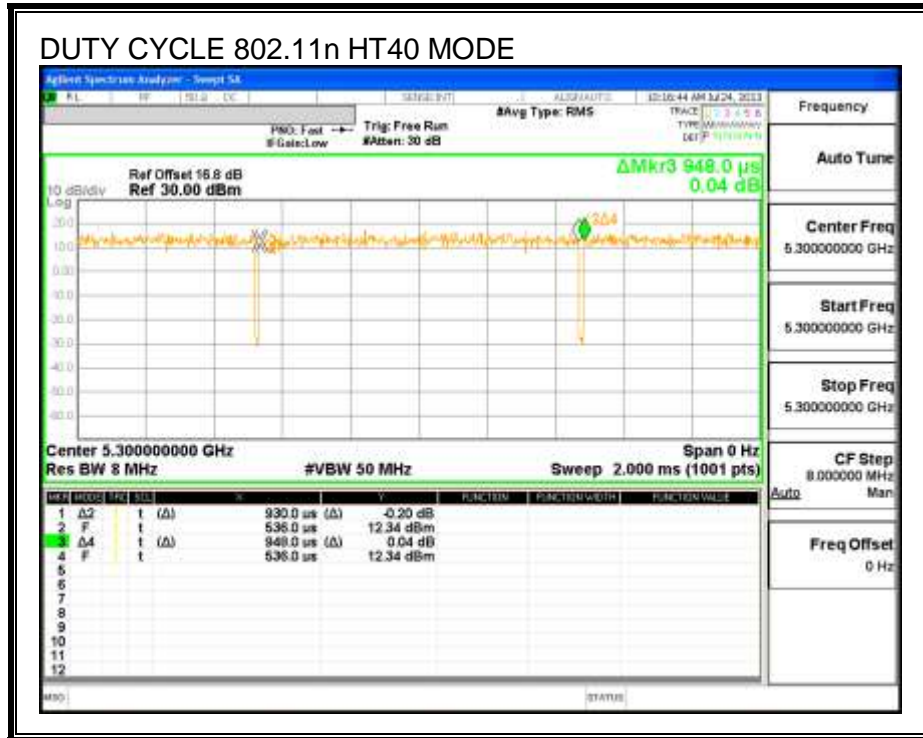

8. ANTENNA PORT TEST RESULTS

8.1. 802.11a SISO MODE IN THE 5.2 GHz BAND

8.1.1. 26 dB BANDWIDTH

LIMITS

None; for reporting purposes only.

RESULTS

Channel	Frequency (MHz)	26 dB Bandwidth (MHz)
Low	5180	19.07
Mid	5200	19.16
High	5240	19.18

26 dB BANDWIDTH

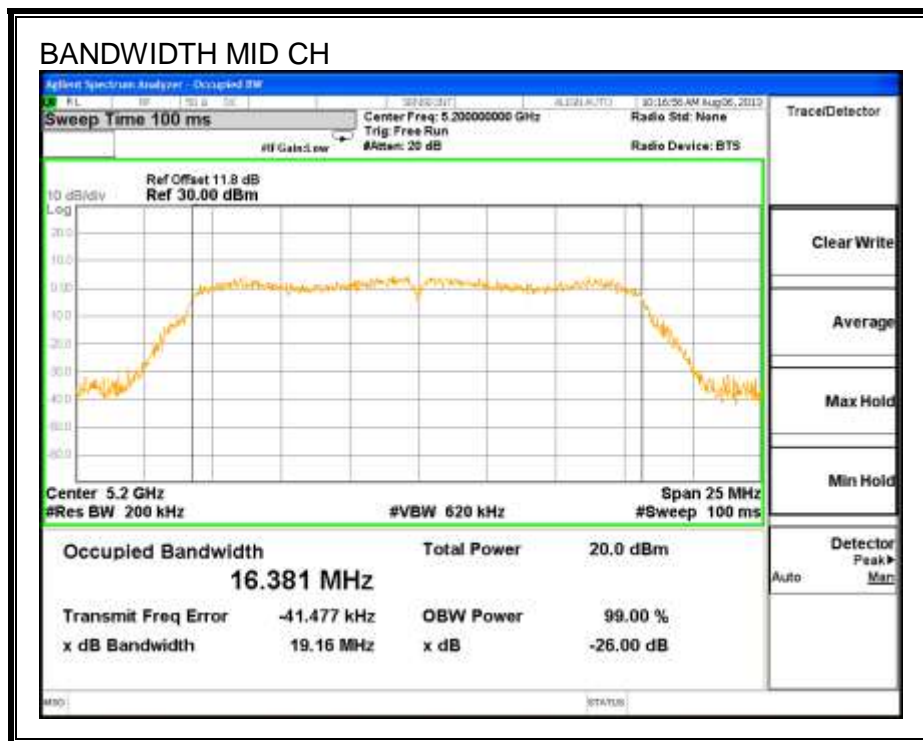
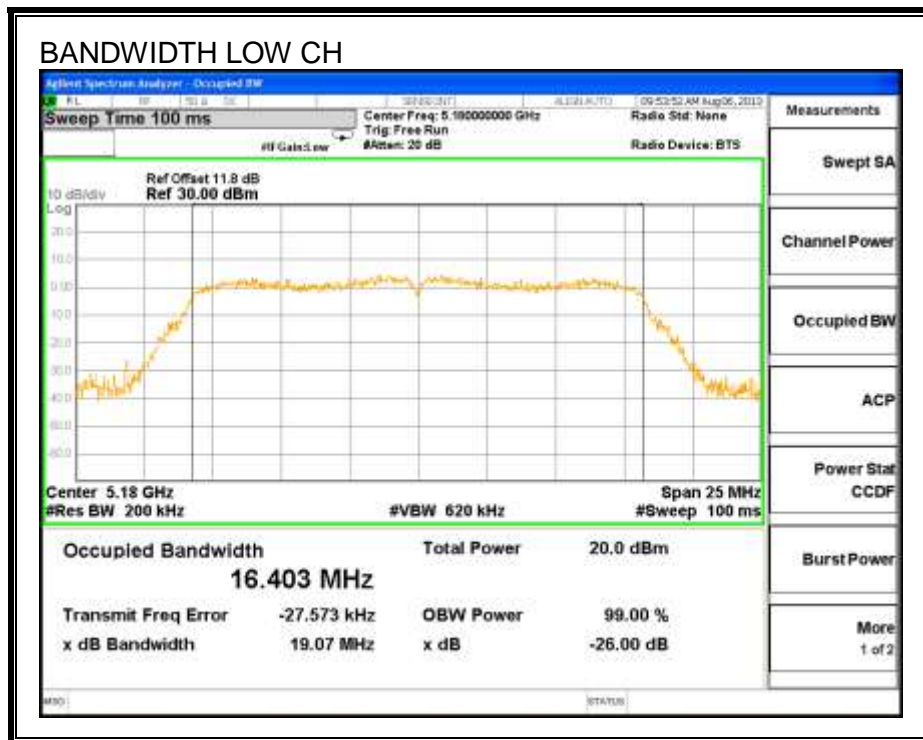

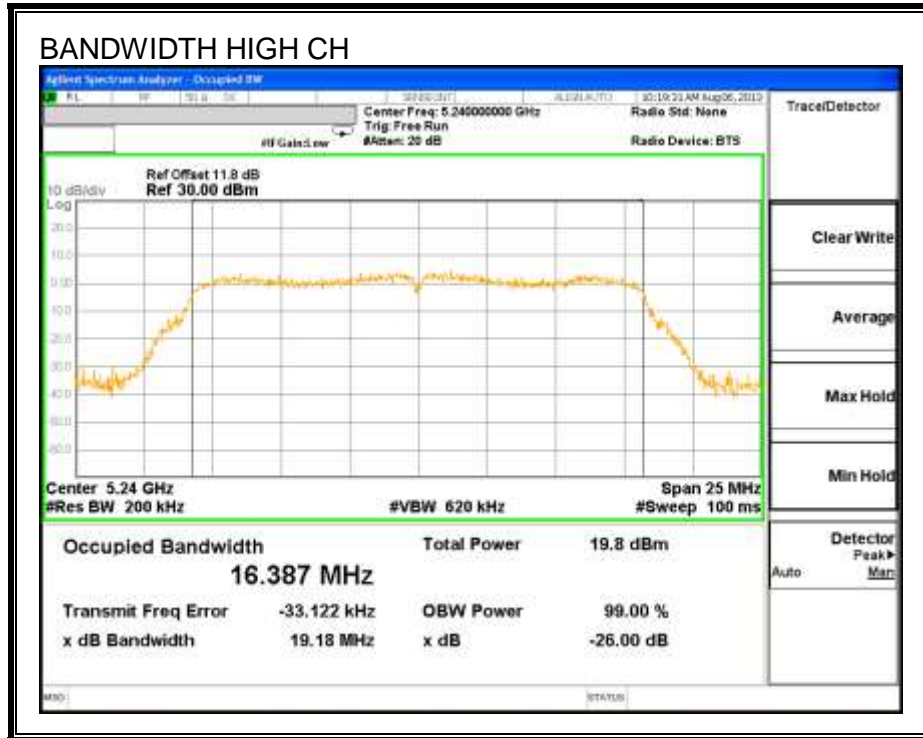

8.1.2. 99% BANDWIDTH

LIMITS

None; for reporting purposes only.

RESULTS

Channel	Frequency (MHz)	99% Bandwidth (MHz)
Low	5180	16.40
Mid	5200	16.64
High	5240	16.70

99% BANDWIDTH

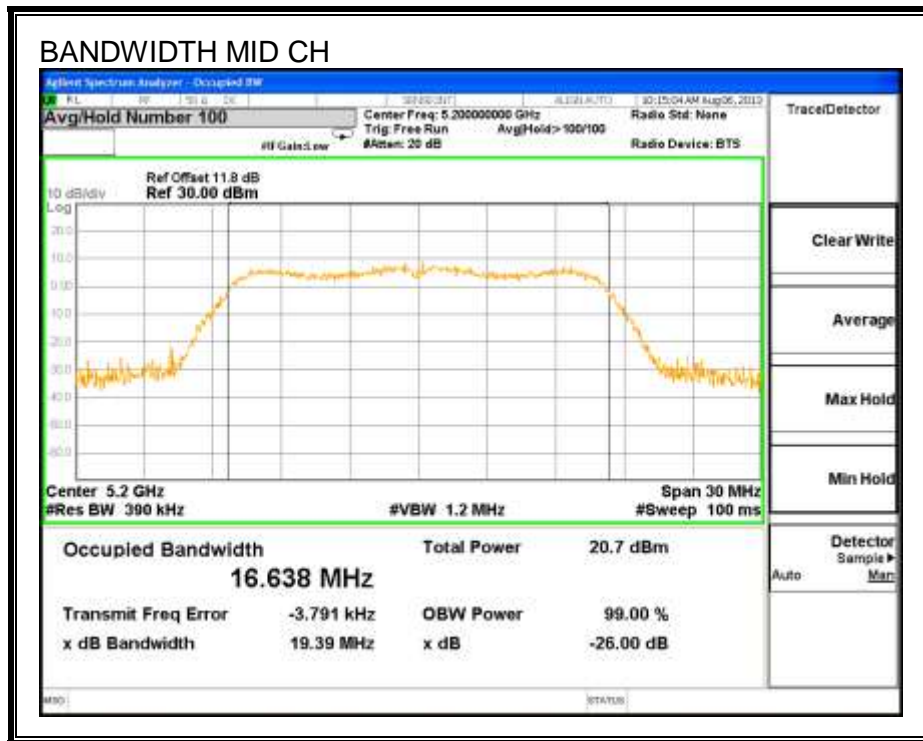
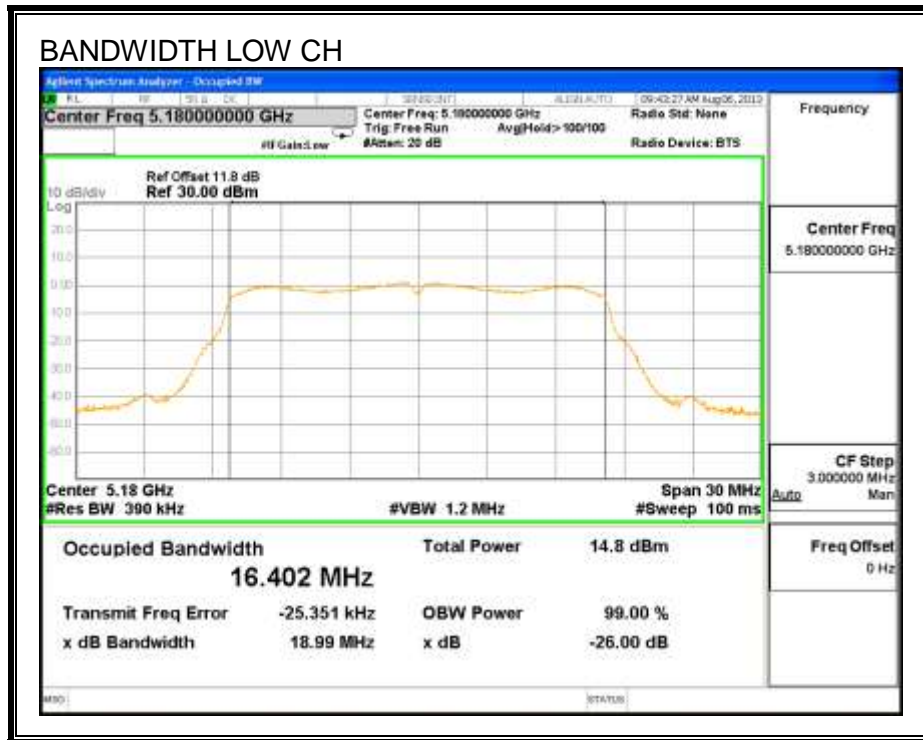

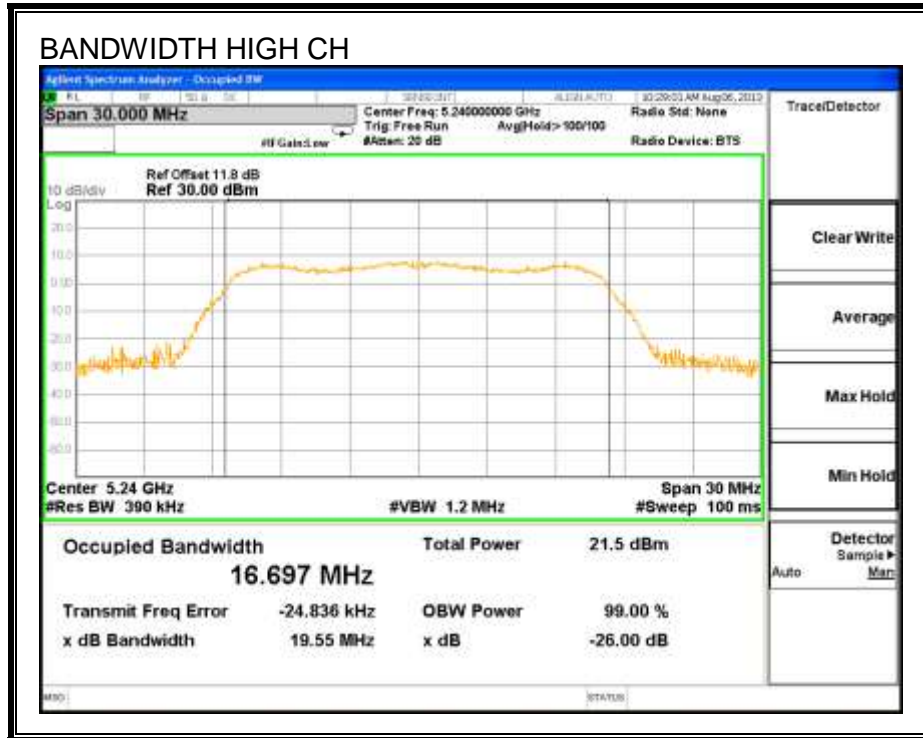

8.1.3. AVERAGE POWER

LIMITS

None; for reporting purposes only.

TEST PROCEDURE

The transmitter output is connected to a power meter.

The cable assembly insertion loss of 11.9 dB (including 10 dB pad and 1.9 dB cable) was entered as an offset in the power meter to allow for direct reading of power.

RESULTS

Channel	Frequency (MHz)	Power (dBm)
Low	5180	14.0
Mid	5200	14.0
High	5240	14.0

8.1.4. OUTPUT POWER AND PSD

LIMITS

FCC §15.407 (a) (1)

For the band 5.15–5.25 GHz, the maximum conducted output power over the frequency band of operation shall not exceed the lesser of 50 mW or $4 \text{ dBm} + 10 \log B$, where B is the 26–dB emission bandwidth in MHz. In addition, the peak power spectral density shall not exceed 4 dBm in any 1–MHz band. If transmitting antennas of directional gain greater than 6 dBi are used, both the maximum conducted output power and the peak power spectral density shall be reduced by the amount in dB that the directional gain of the antenna exceeds 6 dBi.

IC RSS-210 A9.2 (1)

The maximum e.i.r.p. shall not exceed 200 mW or $10 + 10 \log_{10} B$, dBm, whichever power is less. B is the 99% emission bandwidth in MHz. The e.i.r.p. spectral density shall not exceed 10 dBm in any 1.0 MHz band.

DIRECTIONAL ANTENNA GAIN

There is only one transmitter output therefore the directional gain is equal to the antenna gain.

RESULTS

Bandwidth and Antenna Gain

Channel	Frequency (MHz)	Min 26 dB BW (MHz)	Min 99% BW (MHz)	Directional Gain (dBi)
Low	5180	19.1	16.4	2.07
Mid	5200	19.2	16.6	2.07
High	5240	19.2	16.7	2.07

Limits

Channel	Frequency (MHz)	FCC Power Limit (dBm)	IC EIRP Limit (dBm)	Max IC Power (dBm)	Power Limit (dBm)	FCC PSD Limit (dBm)	IC eirp PSD Limit (dBm)	PSD Limit (dBm)
Low	5180	16.81	22.15	20.08	16.81	4.00	10.00	4.00
Mid	5200	16.83	22.20	20.13	16.83	4.00	10.00	4.00
High	5240	16.83	22.23	20.16	16.83	4.00	10.00	4.00

Duty Cycle CF (dB)	0.00	Included in Calculations of Corr'd Power & PSD
---------------------------	------	---

Output Power Results

Channel	Frequency (MHz)	Chain 0 Meas Power (dBm)	Total Corr'd Power (dBm)	Power Limit (dBm)	Power Margin (dB)
Low	5180	14.08	14.08	16.81	-2.73
Mid	5200	14.07	14.07	16.83	-2.76
High	5240	14.02	14.02	16.83	-2.81

PSD Results

Channel	Frequency (MHz)	Chain 0 Meas PSD (dBm)	Total Corr'd PSD (dBm)	PSD Limit (dBm)	PSD Margin (dB)
Low	5180	2.47	2.47	4.00	-1.53
Mid	5200	2.79	2.79	4.00	-1.21
High	5240	2.75	2.75	4.00	-1.26

OUTPUT POWER AND PSD, Chain 0

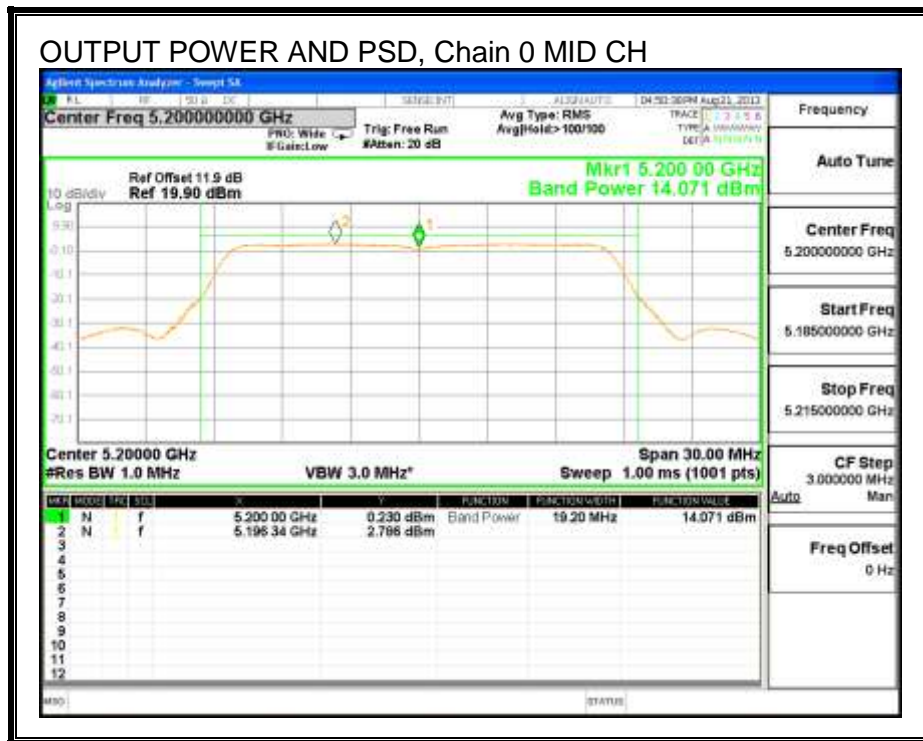
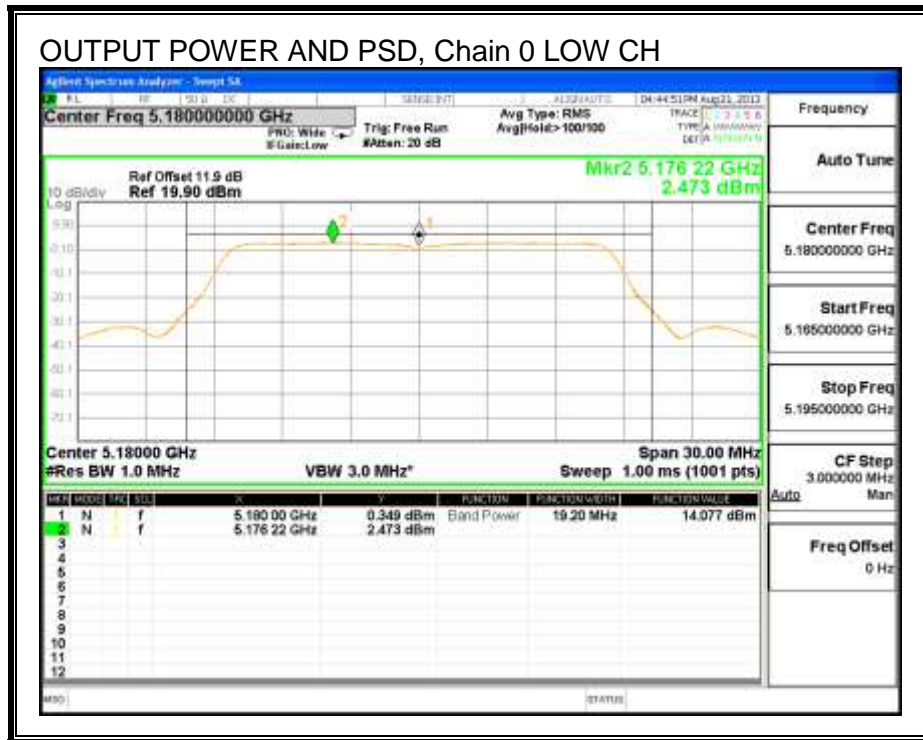

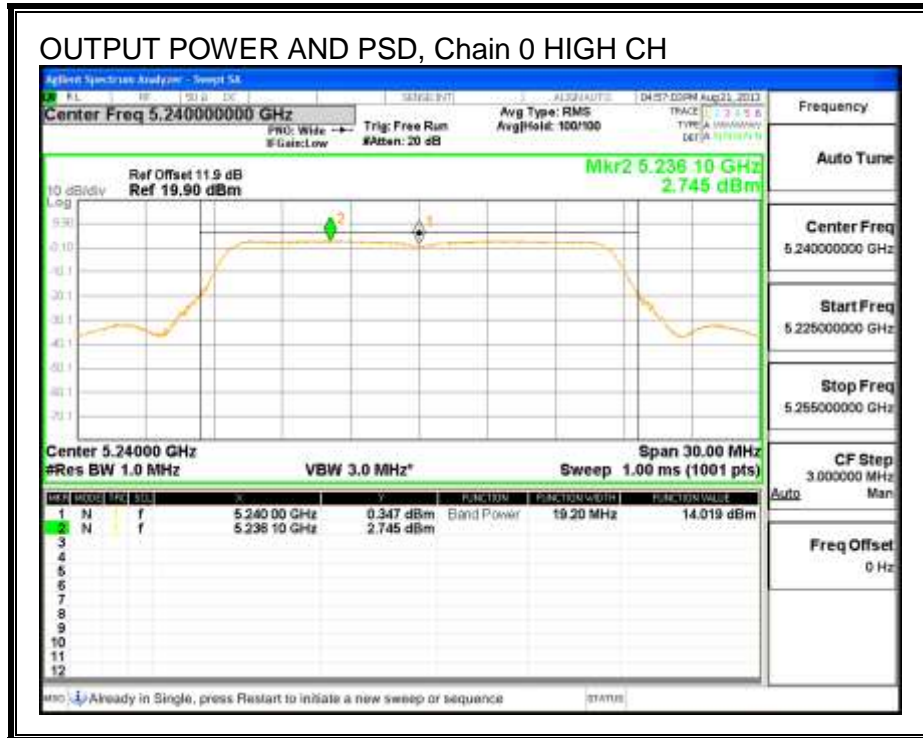

8.2. 802.11n HT20 2TX CDD MODE IN THE 5.2 GHZ BAND

8.2.1. 26 dB BANDWIDTH

LIMITS

None; for reporting purposes only.

RESULTS

Channel	Frequency (MHz)	26 dB BW Chain 0 (MHz)	26 dB BW Chain 1 (MHz)
Low	5180	20.16	20.20
Mid	5200	20.20	20.40
High	5240	20.42	20.16

26 dB BANDWIDTH, Chain 0

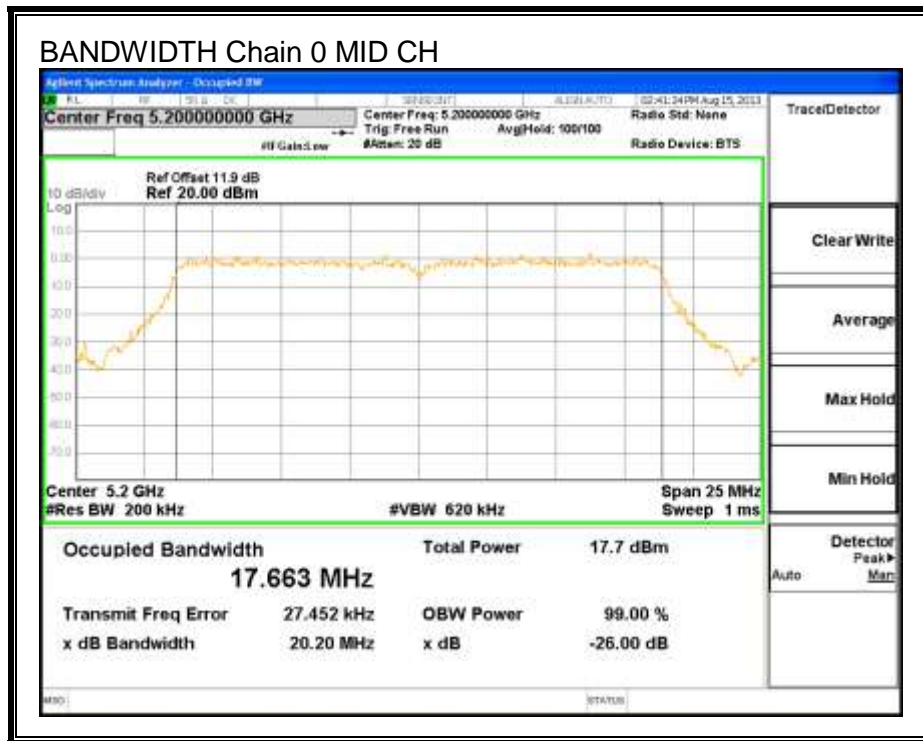
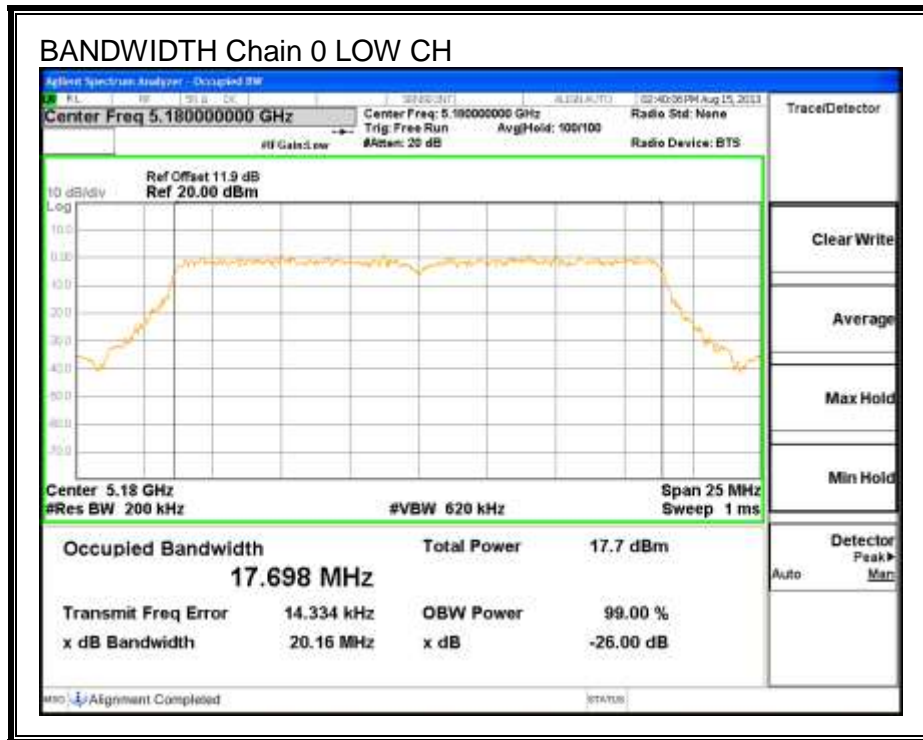

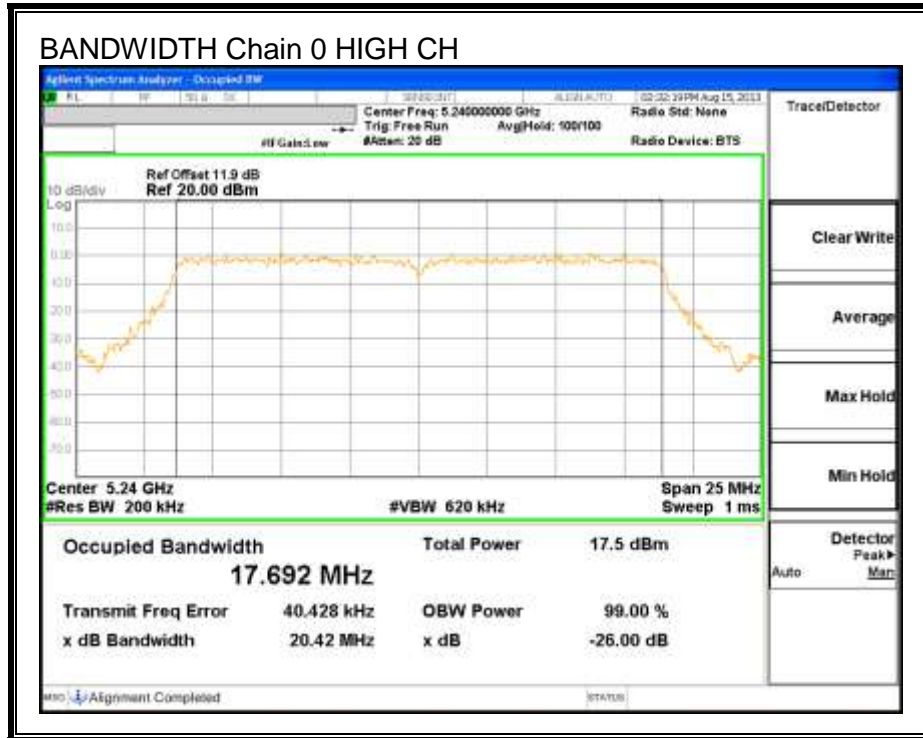

26 dB BANDWIDTH, Chain 1

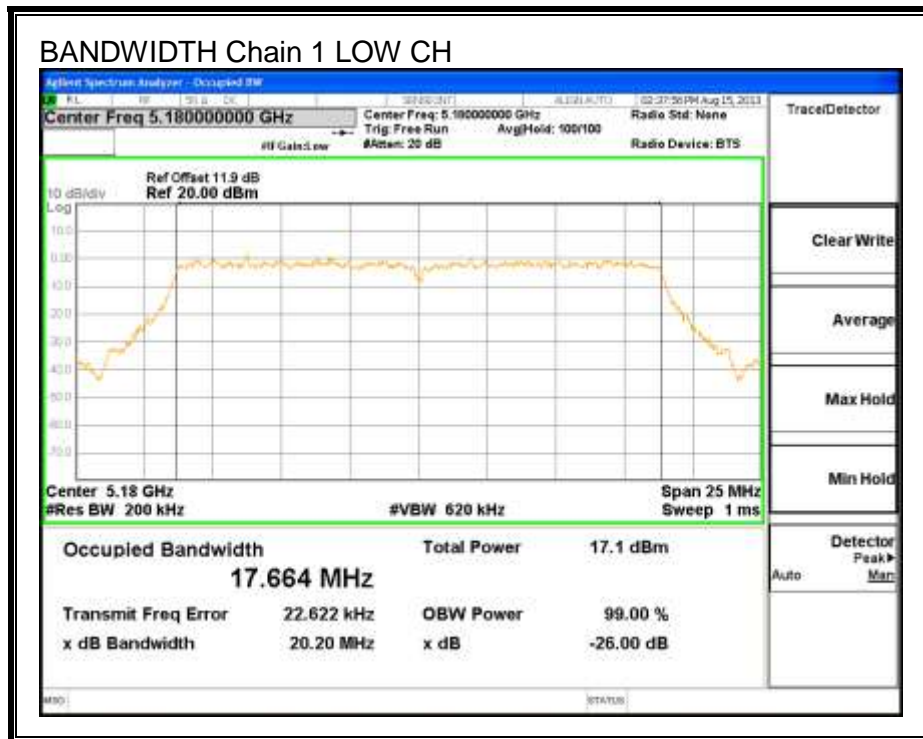

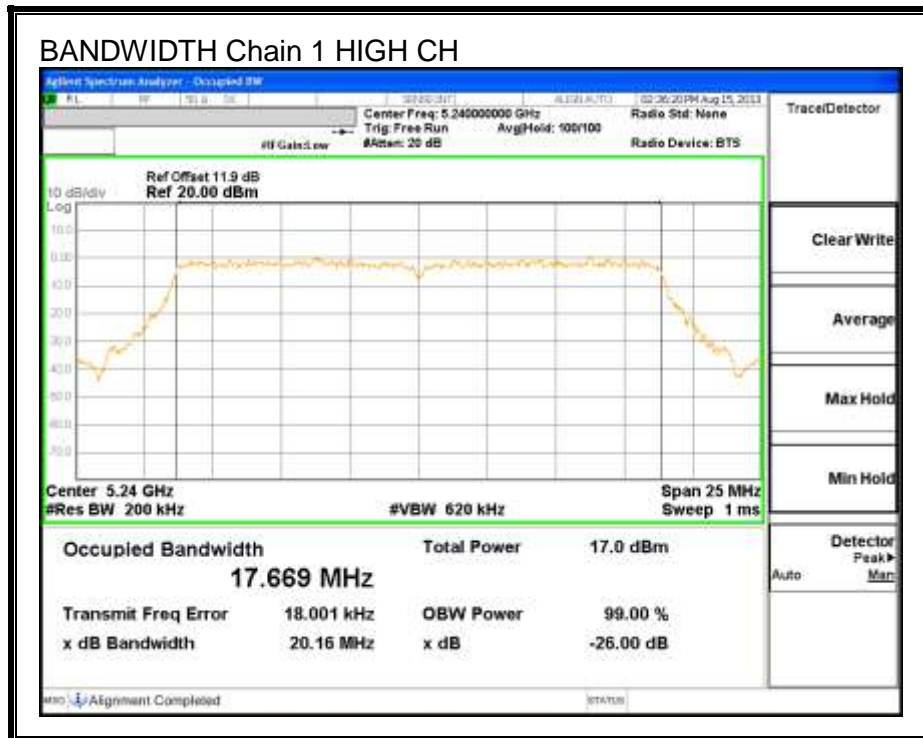
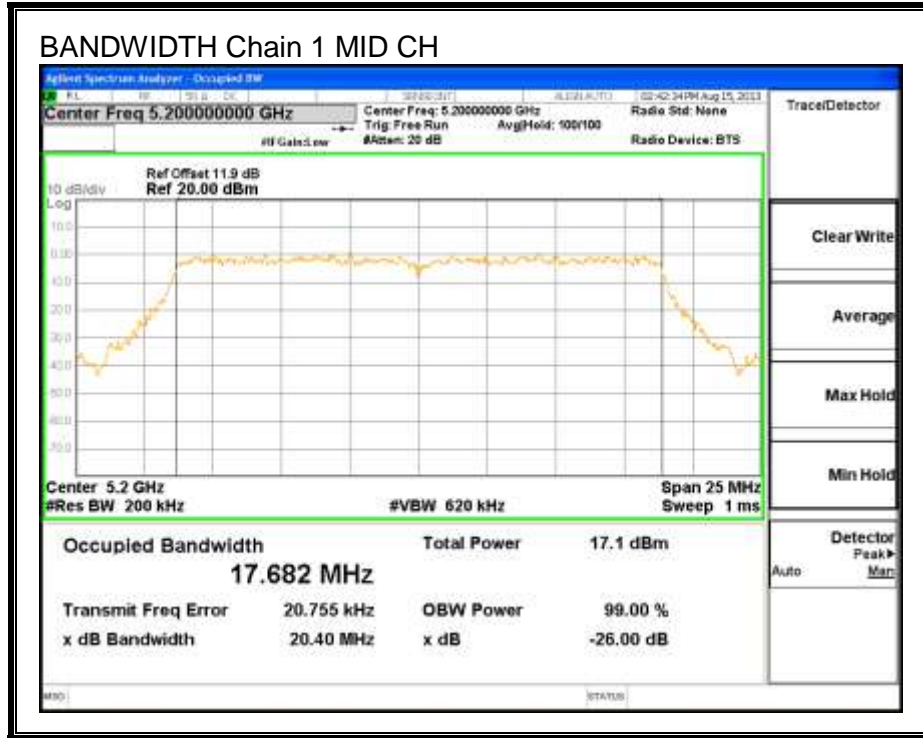

8.2.2. 99% BANDWIDTH

LIMITS

None; for reporting purposes only.

RESULTS

Channel	Frequency (MHz)	99% BW Chain 0 (MHz)	99% BW Chain 1 (MHz)
Low	5180	17.877	17.774
Mid	5200	17.887	17.795
High	5240	17.846	17.823

99% BANDWIDTH, Chain 0

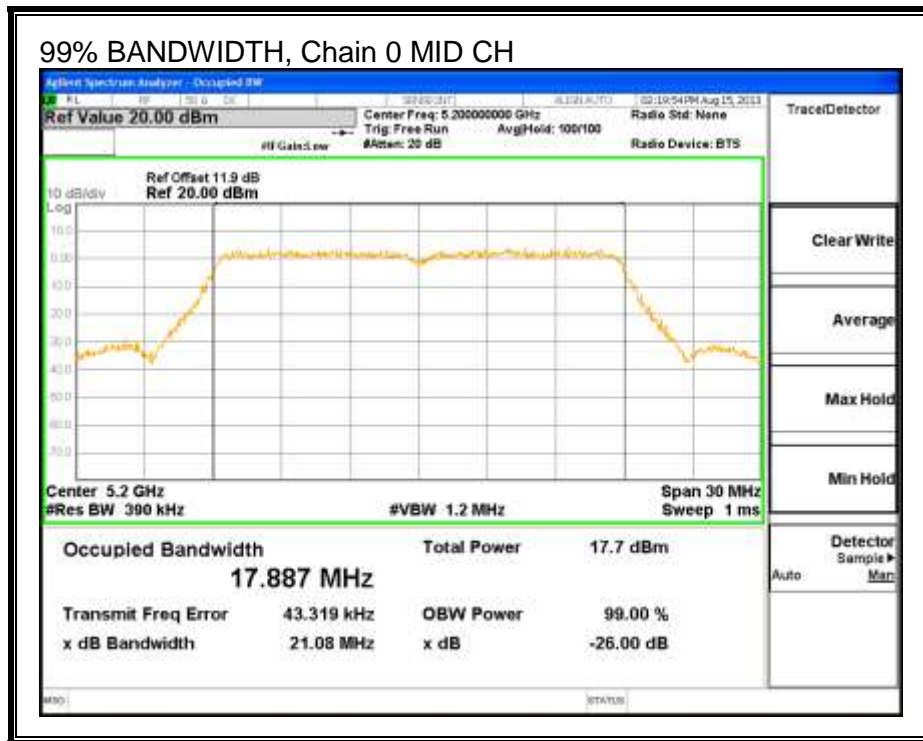
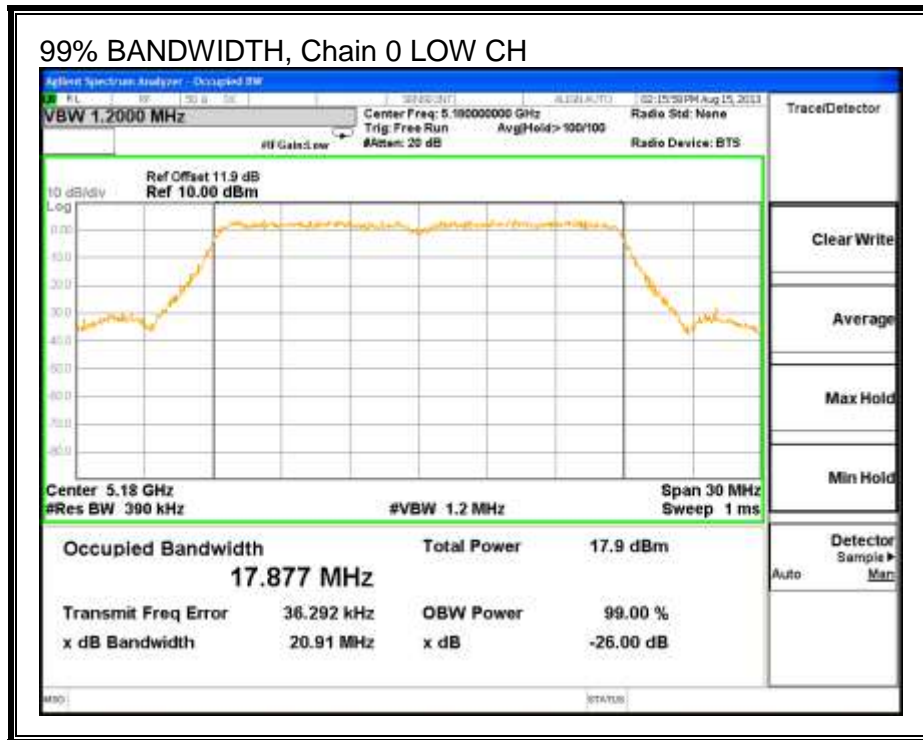

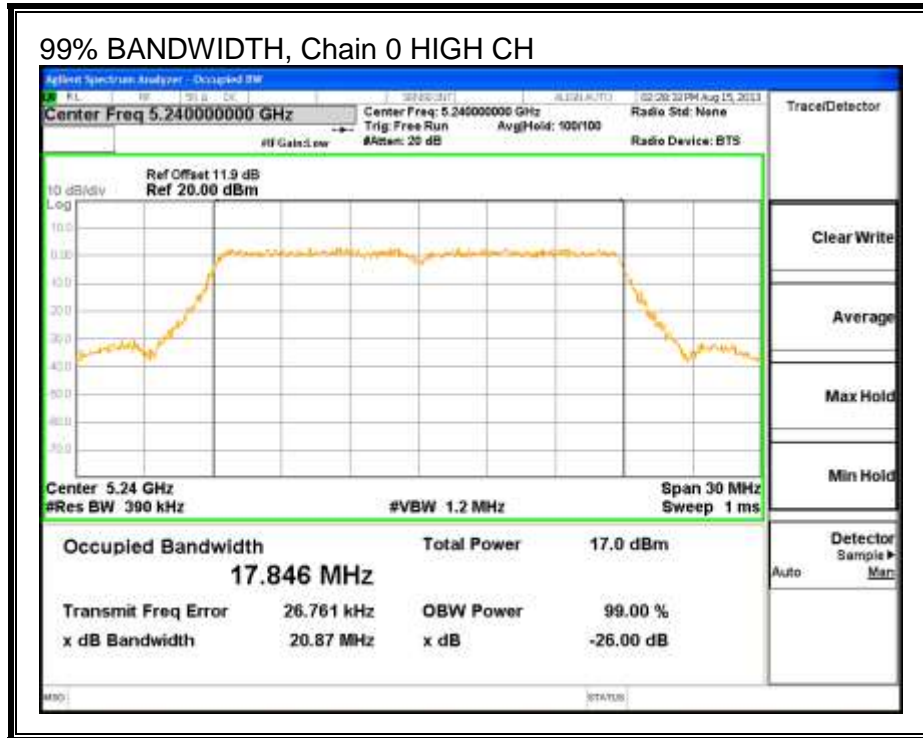

99% BANDWIDTH, Chain 1

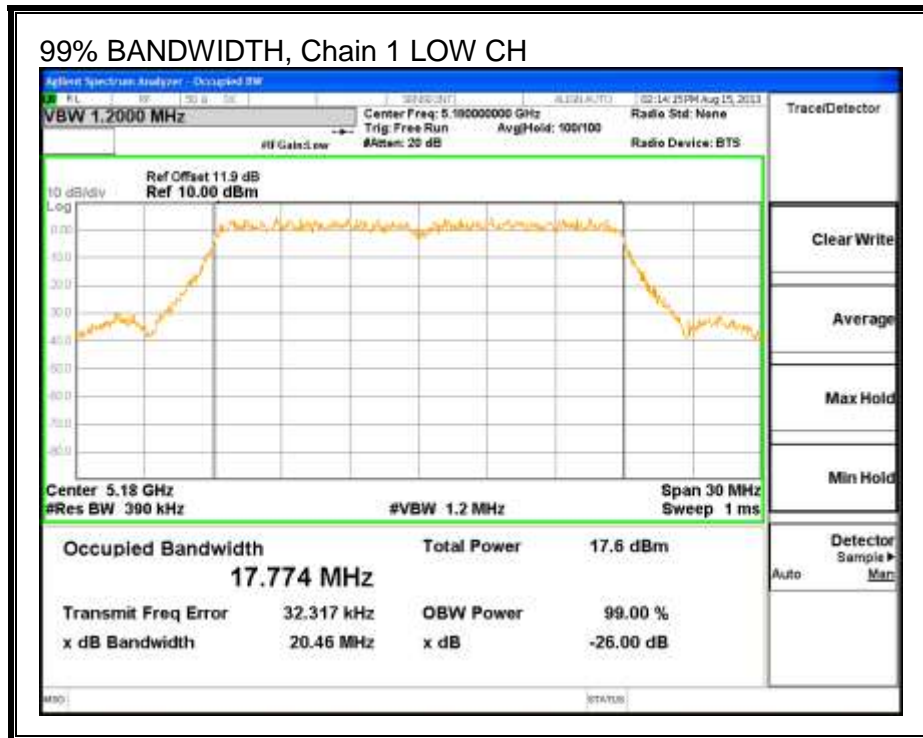

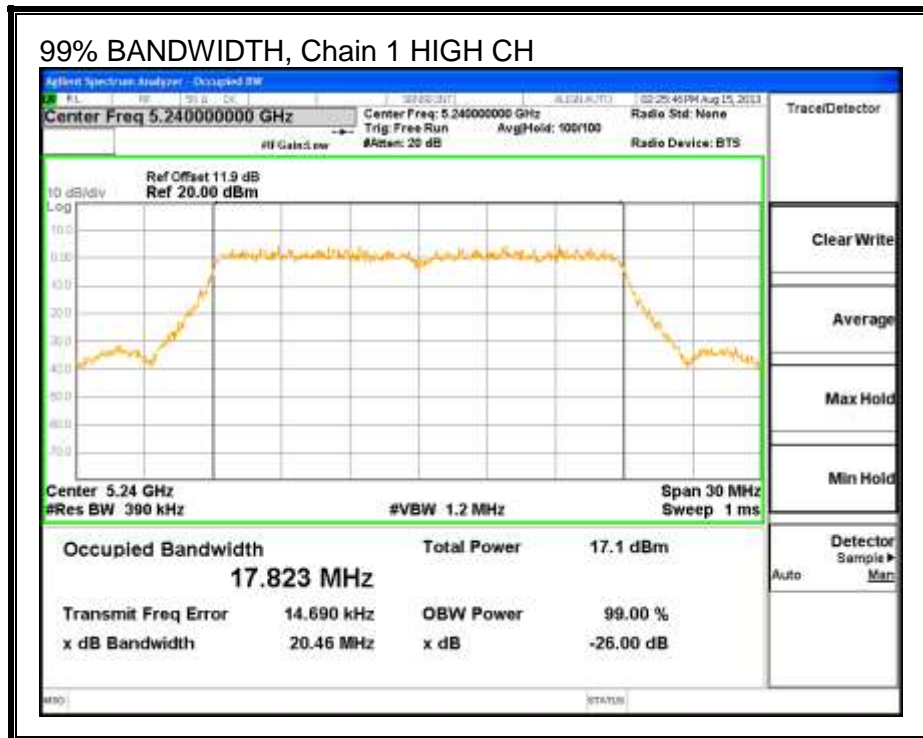
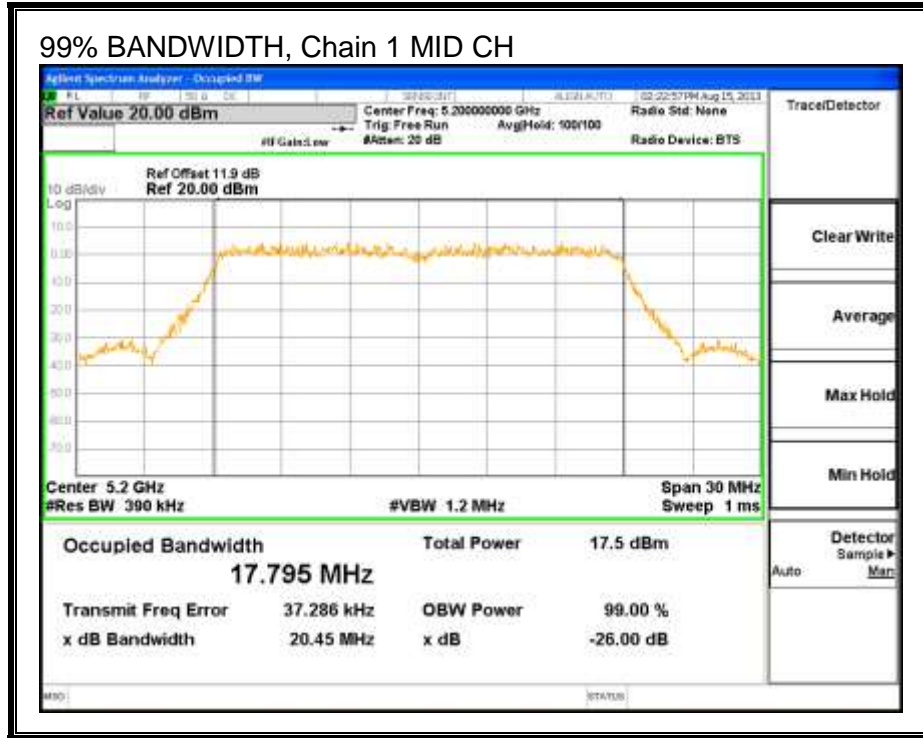

8.2.3. AVERAGE POWER

LIMITS

None; for reporting purposes only.

TEST PROCEDURE

The transmitter output is connected to a power meter.

The cable assembly insertion loss of 11.9 dB (including 10 dB pad and 1.9 dB cable) was entered as an offset in the power meter to allow for direct reading of power.

RESULTS

Average Power Results

Channel	Frequency (MHz)	Chain 0 Power (dBm)	Chain 1 Power (dBm)	Total Power (dBm)
Low	5180	10.40	10.50	13.46
Mid	5200	10.49	10.50	13.51
High	5240	10.38	10.40	13.40

8.2.4. OUTPUT POWER AND PPSD

LIMITS

FCC §15.407 (a) (1)

For the band 5.15–5.25 GHz, the maximum conducted output power over the frequency band of operation shall not exceed the lesser of 50 mW or 4 dBm + 10 log B, where B is the 26–dB emission bandwidth in MHz. In addition, the peak power spectral density shall not exceed 4 dBm in any 1–MHz band. If transmitting antennas of directional gain greater than 6 dBi are used, both the maximum conducted output power and the peak power spectral density shall be reduced by the amount in dB that the directional gain of the antenna exceeds 6 dBi.

IC RSS-210 A9.2 (1)

The maximum e.i.r.p. shall not exceed 200 mW or 10 + 10 log₁₀ B, dBm, whichever power is less. B is the 99% emission bandwidth in MHz. The e.i.r.p. spectral density shall not exceed 10 dBm in any 1.0 MHz band.

DIRECTIONAL ANTENNA GAIN

For output power, the TX chains are uncorrelated and the antenna gain is unequal among the chains. The directional gain is:

Chain 0 Antenna Gain (dBi)	Chain 1 Antenna Gain (dBi)	Uncorrelated Chains Directional Gain (dBi)
2.37	2.07	2.22

For PPSD, the TX chains are correlated and the antenna gain is unequal among the chains. The directional gain is:

Chain 0 Antenna Gain (dBi)	Chain 1 Antenna Gain (dBi)	Correlated Chains Directional Gain (dBi)
2.37	2.07	5.23

RESULTS

Bandwidth and Antenna Gain

Channel	Frequency (MHz)	Min 26 dB BW (MHz)	Min 99% BW (MHz)	Uncorrelated Directional Gain (dBi)	Correlated Directional Gain (dBi)
Low	5180	20.2	17.8	2.22	5.23
Mid	5200	20.2	17.8	2.22	5.23
High	5240	20.2	17.8	2.22	5.23

Limits

Channel	Frequency (MHz)	FCC Power Limit (dBm)	IC EIRP Limit (dBm)	Max IC Power (dBm)	Power Limit (dBm)	FCC PPSD Limit (dBm)	IC eirp PSD Limit (dBm)	PPSD Limit (dBm)
Low	5180	17.00	22.50	20.28	17.00	4.00	10.00	4.00
Mid	5200	17.00	22.50	20.28	17.00	4.00	10.00	4.00
High	5240	17.00	22.51	20.29	17.00	4.00	10.00	4.00

Duty Cycle CF (dB)	0.00	Included in Calculations of Corr'd Power & PPSD
---------------------------	------	--

Output Power Results

Channel	Frequency (MHz)	Chain 0 Meas Power (dBm)	Chain 1 Meas Power (dBm)	Total Corr'd Power (dBm)	Power Limit (dBm)	Power Margin (dB)
Low	5180	10.55	10.65	13.61	17.00	-3.39
Mid	5200	10.67	10.75	13.72	17.00	-3.28
High	5240	10.42	10.46	13.45	17.00	-3.55

PPSD Results

Channel	Frequency (MHz)	Chain 0 Meas PPSD (dBm)	Chain 1 Meas PPSD (dBm)	Total Corr'd PPSD (dBm)	PPSD Limit (dBm)	PPSD Margin (dB)
Low	5180	0.35	-1.13	2.68	4.00	-1.32
Mid	5200	-1.04	-0.95	2.02	4.00	-1.98
High	5240	0.31	0.19	3.26	4.00	-0.74

OUTPUT POWER AND PPSD, Chain 0

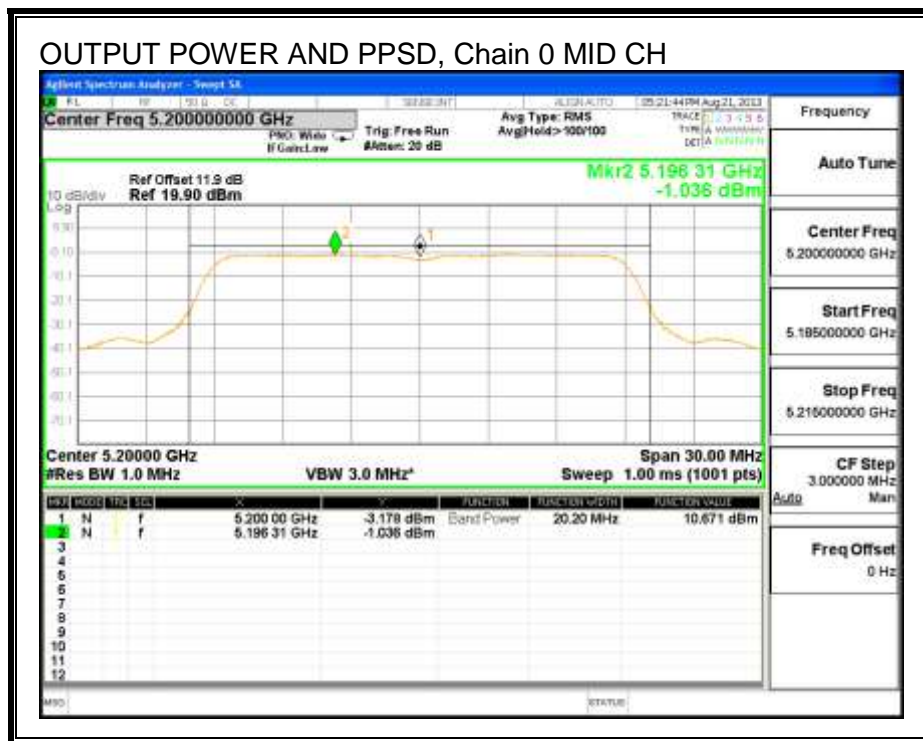
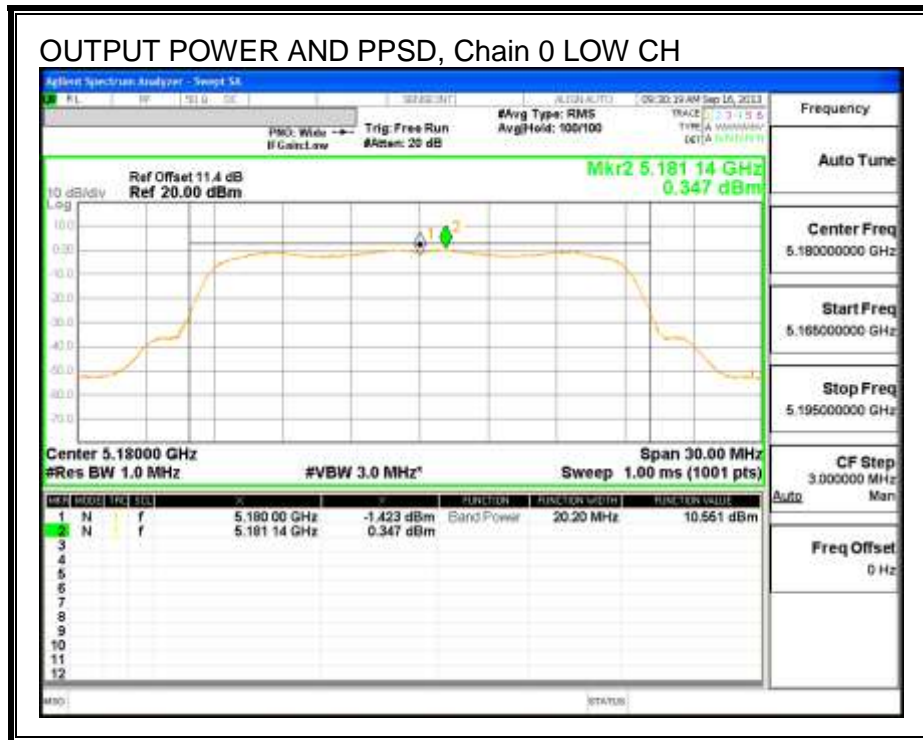

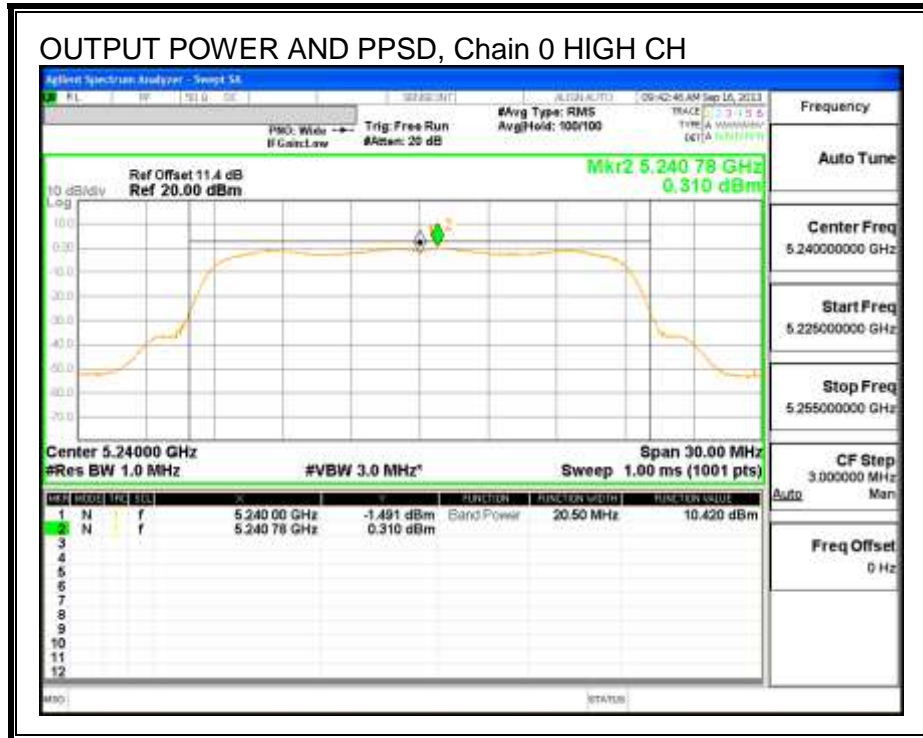

OUTPUT POWER AND PPSD, Chain 1

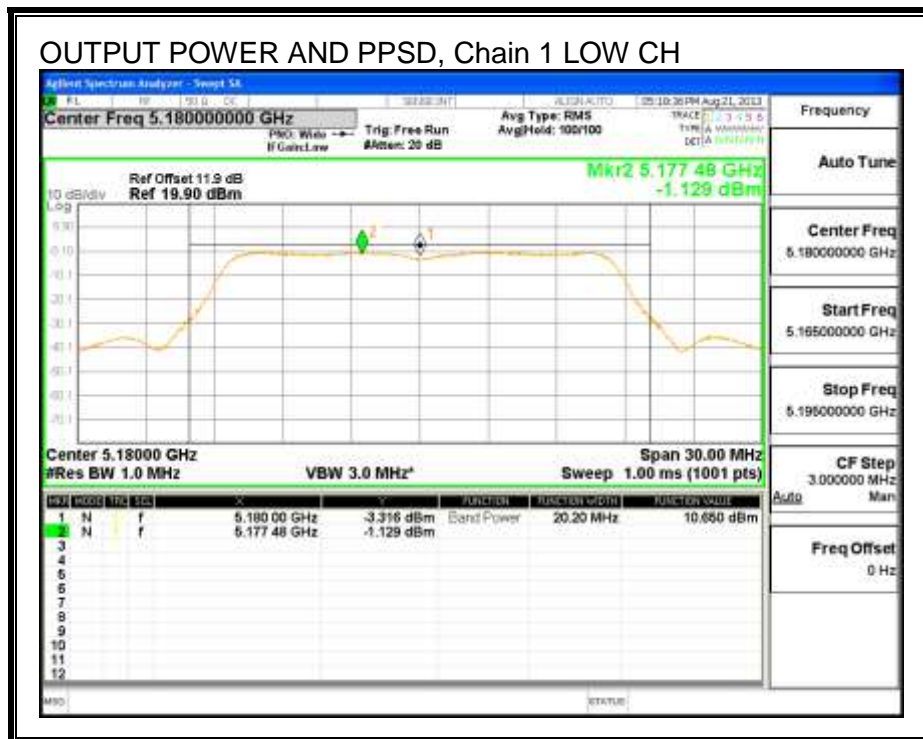

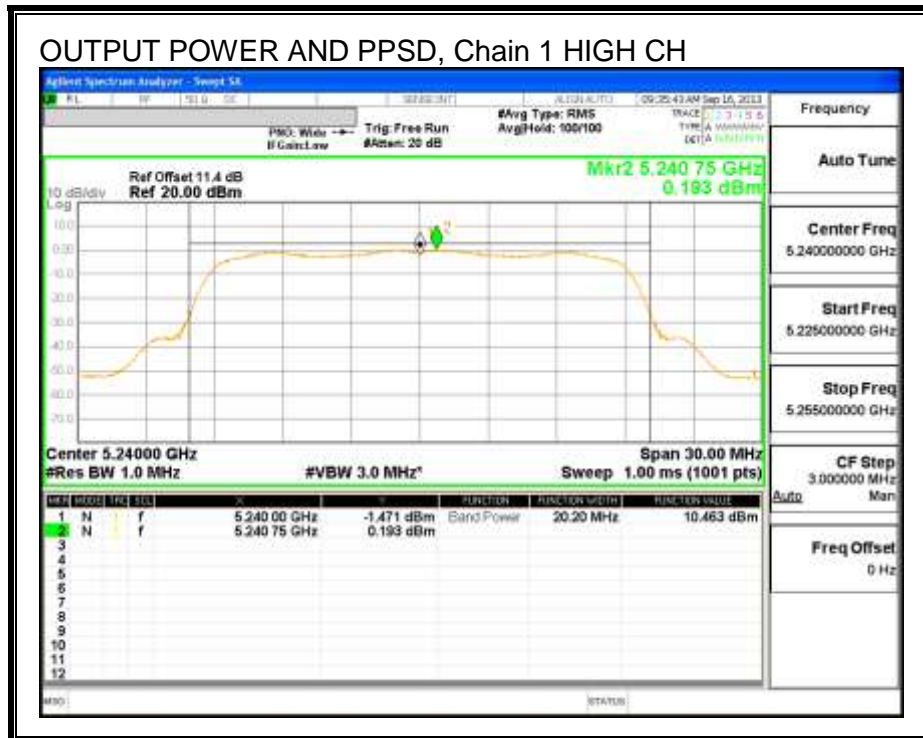
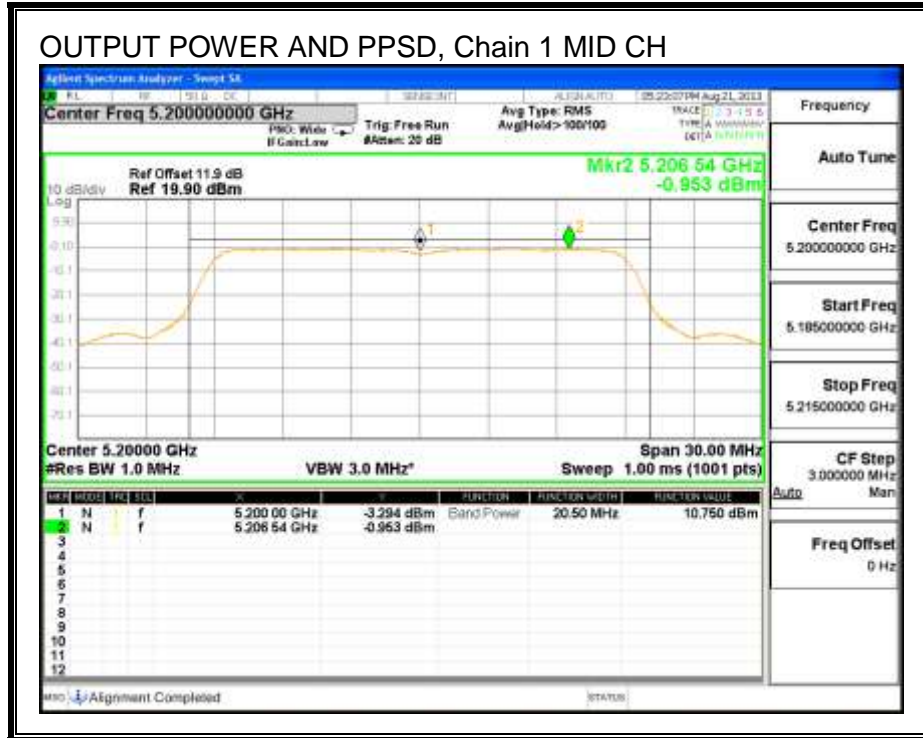

8.3. 802.11n HT20 2TX STBC MODE IN THE 5.2 GHz BAND

8.3.1. 26 dB BANDWIDTH

LIMITS

None; for reporting purposes only.

RESULTS

Channel	Frequency (MHz)	26 dB BW Chain 0 (MHz)	26 dB BW Chain 1 (MHz)
Low	5180	20.73	20.58
Mid	5200	20.79	20.76
High	5240	20.64	20.58

26 dB BANDWIDTH, Chain 0

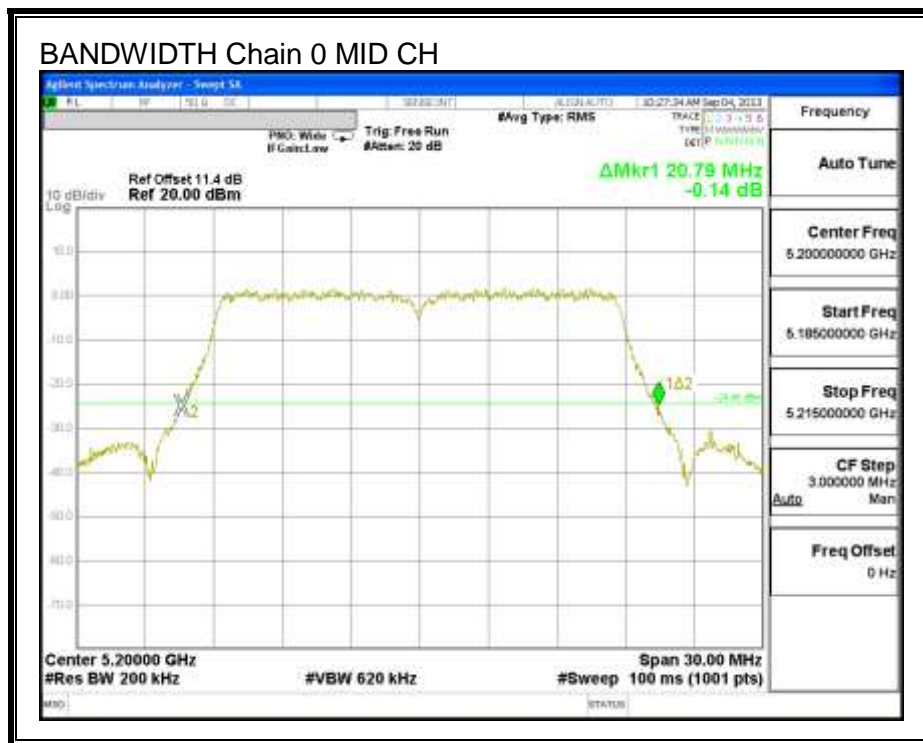
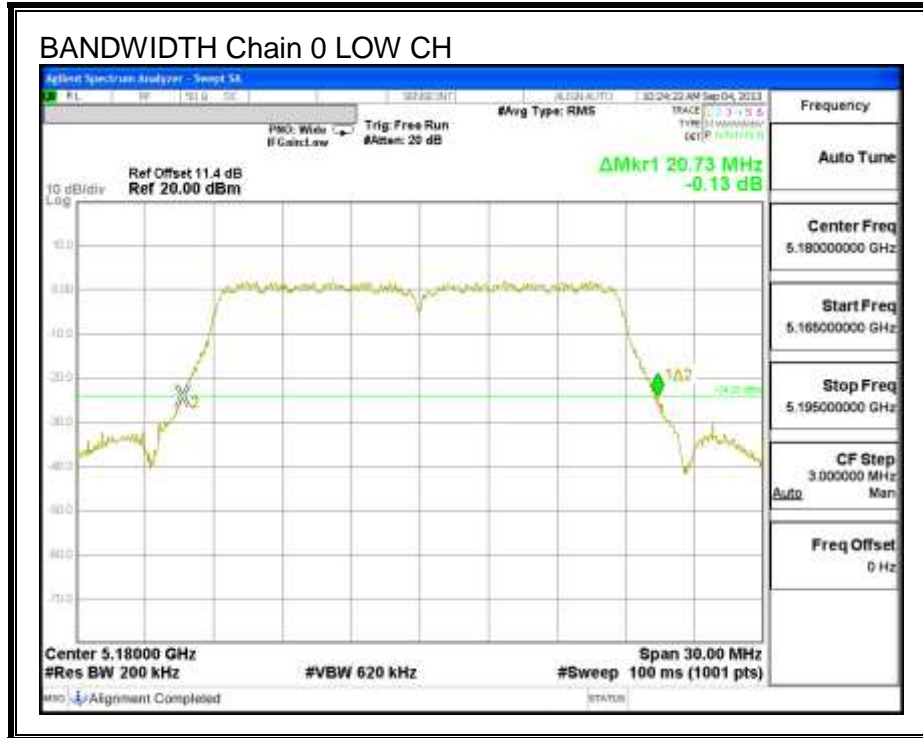

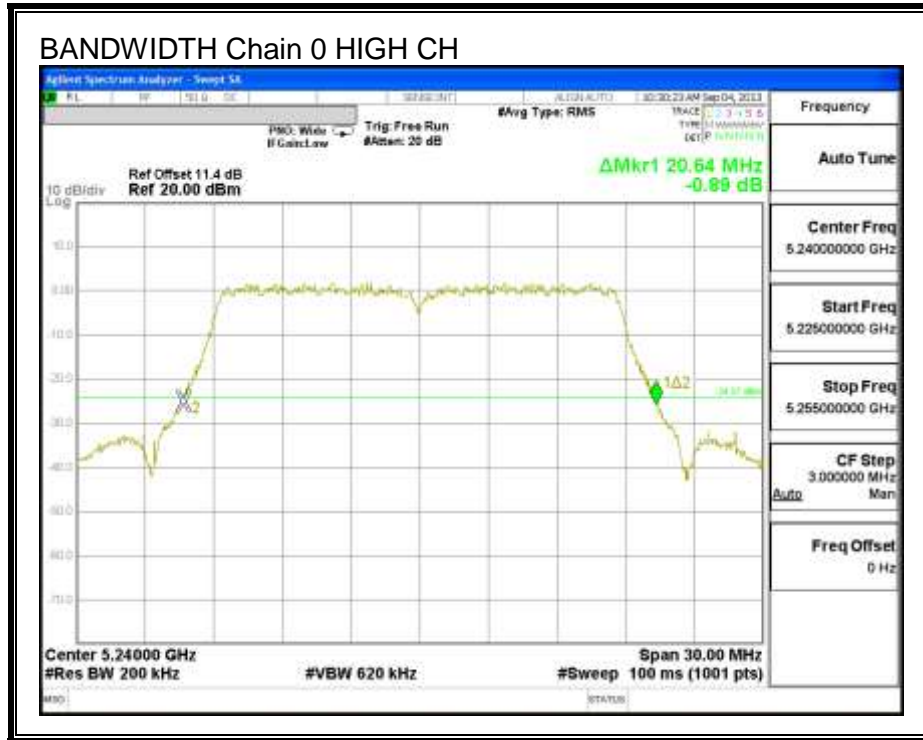

26 dB BANDWIDTH, Chain 1

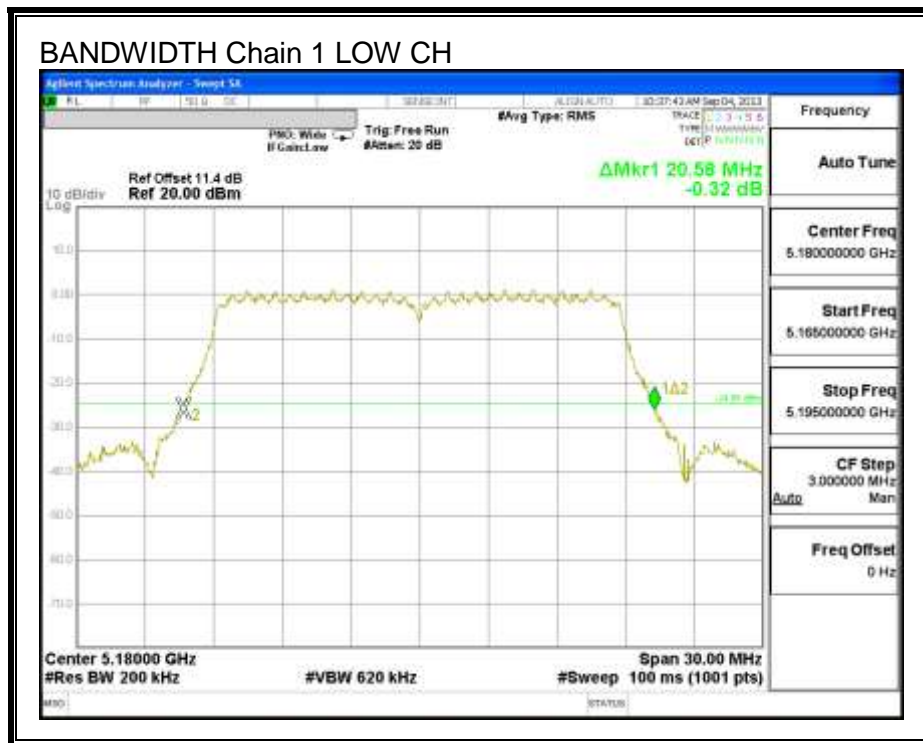

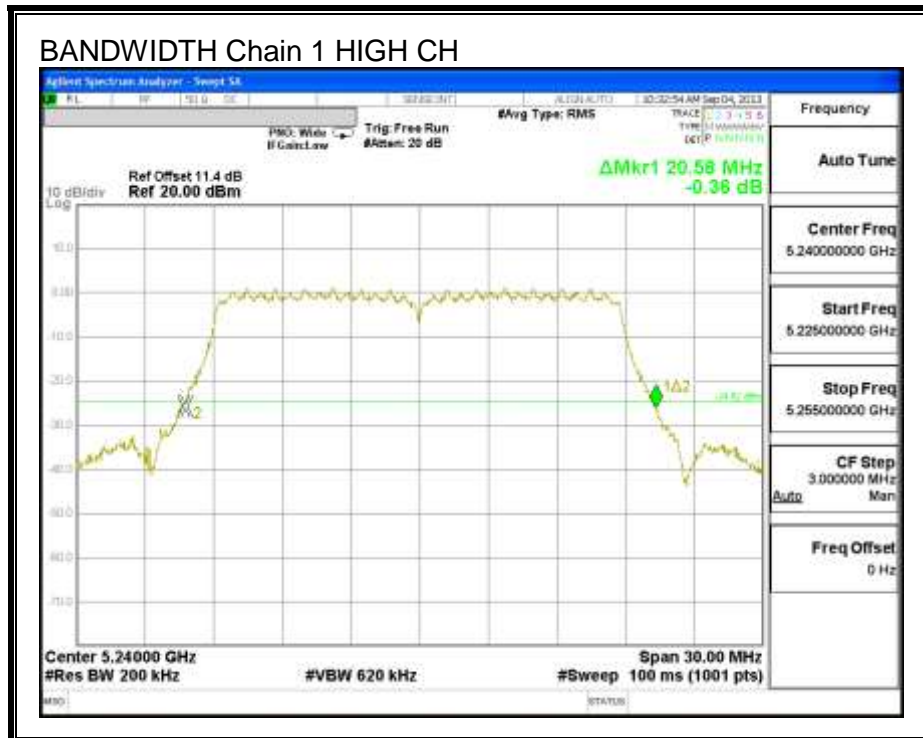
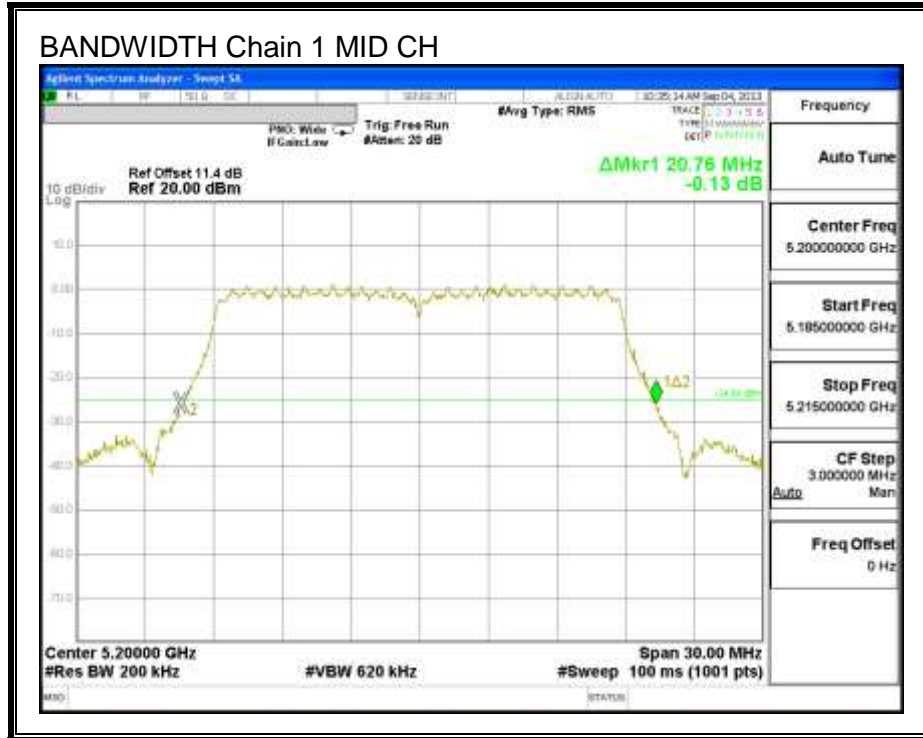

8.3.2. 99% BANDWIDTH

LIMITS

None; for reporting purposes only.

RESULTS

Channel	Frequency (MHz)	99% BW Chain 0 (MHz)	99% BW Chain 1 (MHz)
Low	5180	17.639	17.611
Mid	5200	17.642	17.689
High	5240	17.612	17.687

99% BANDWIDTH, Chain 0

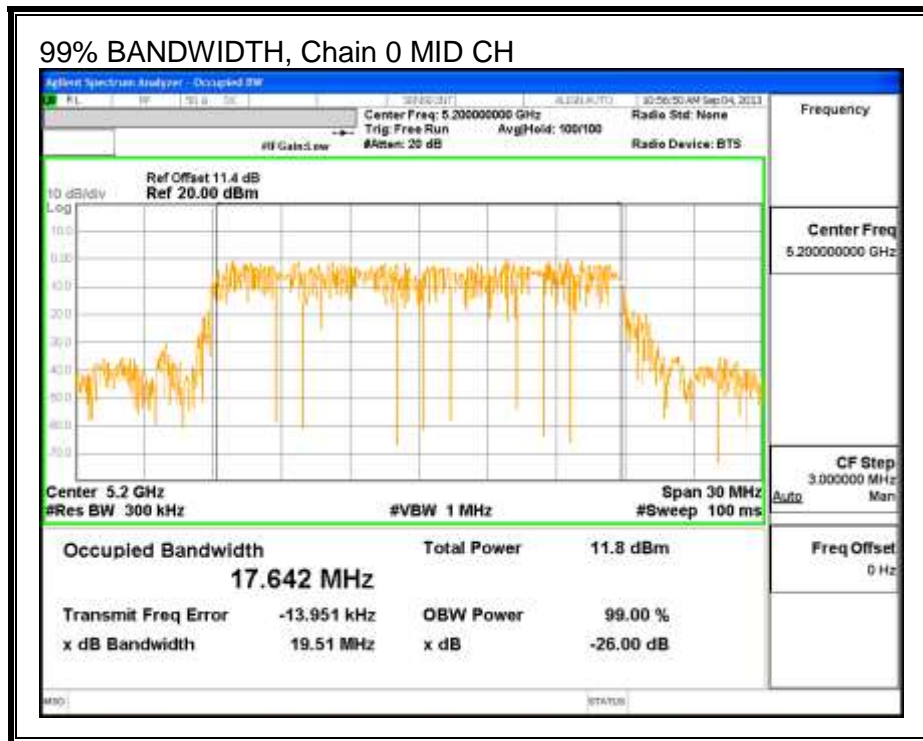
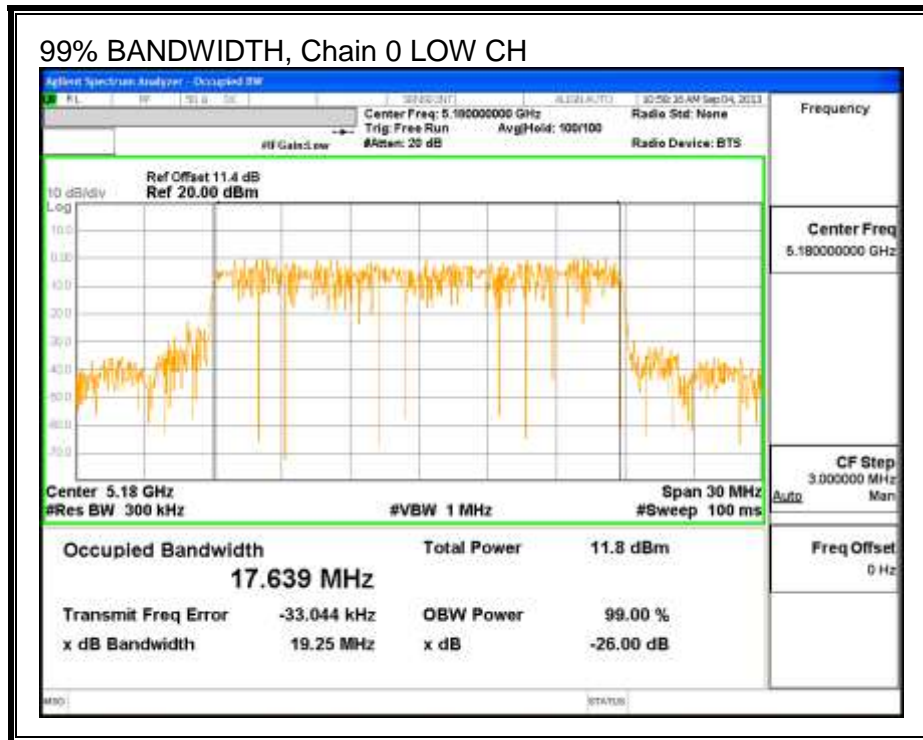

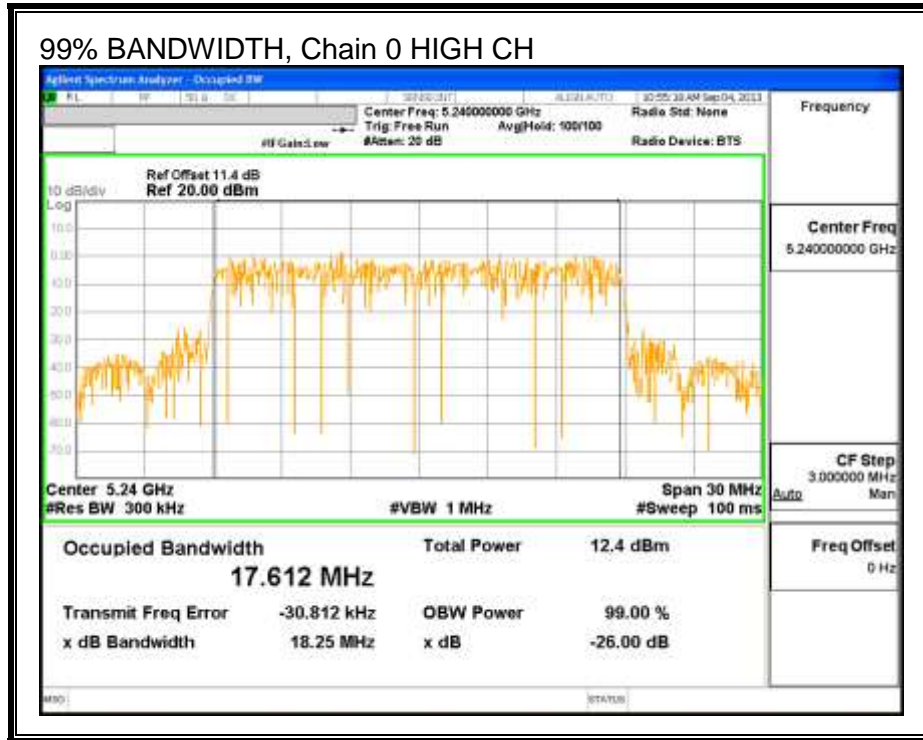

99% BANDWIDTH, Chain 1

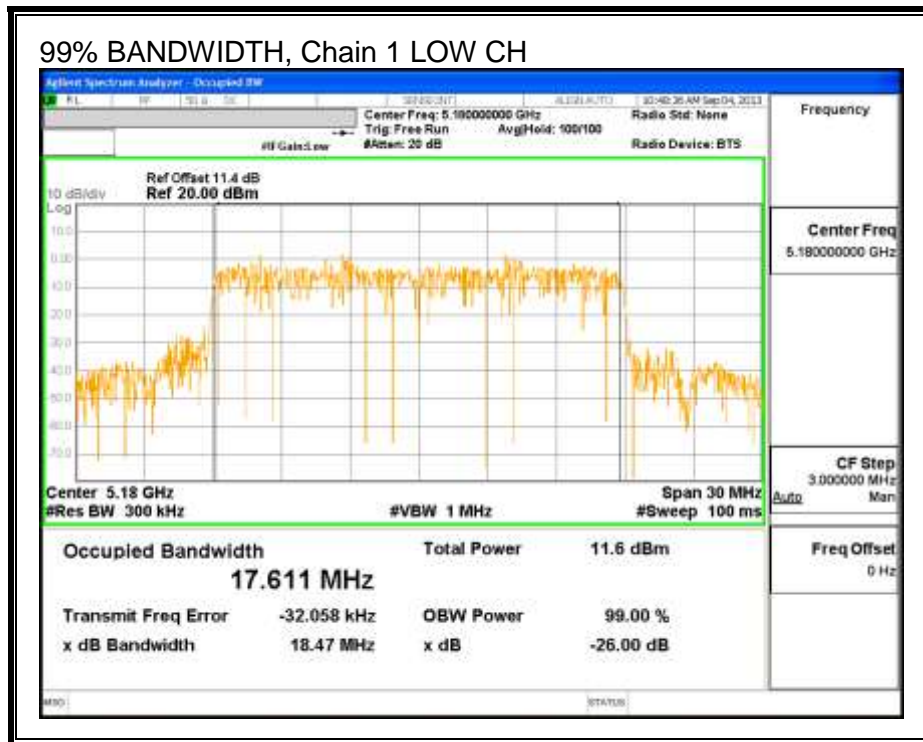

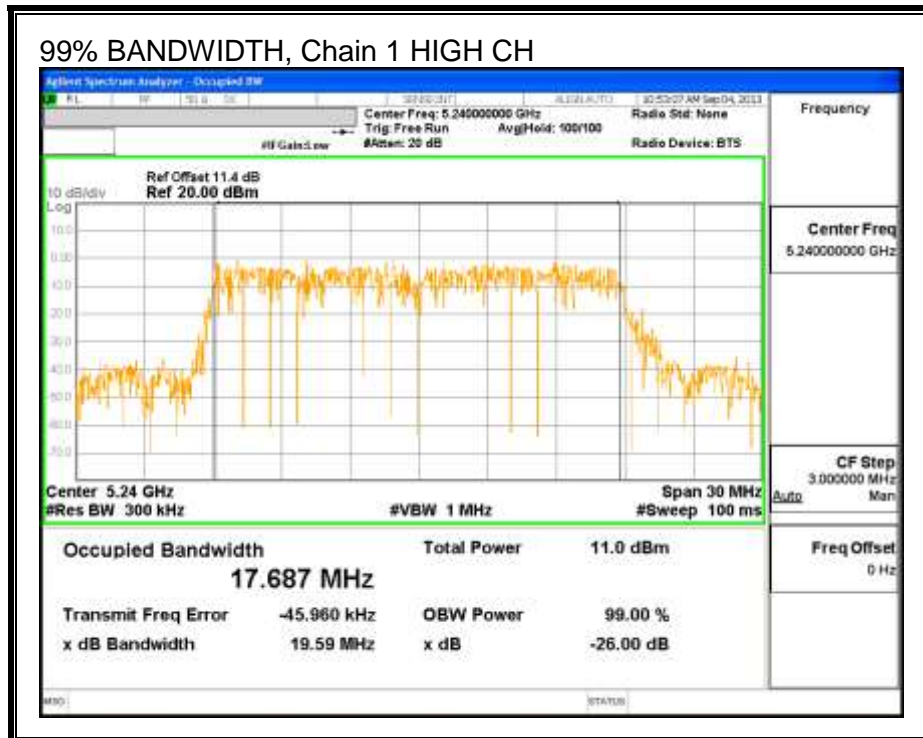
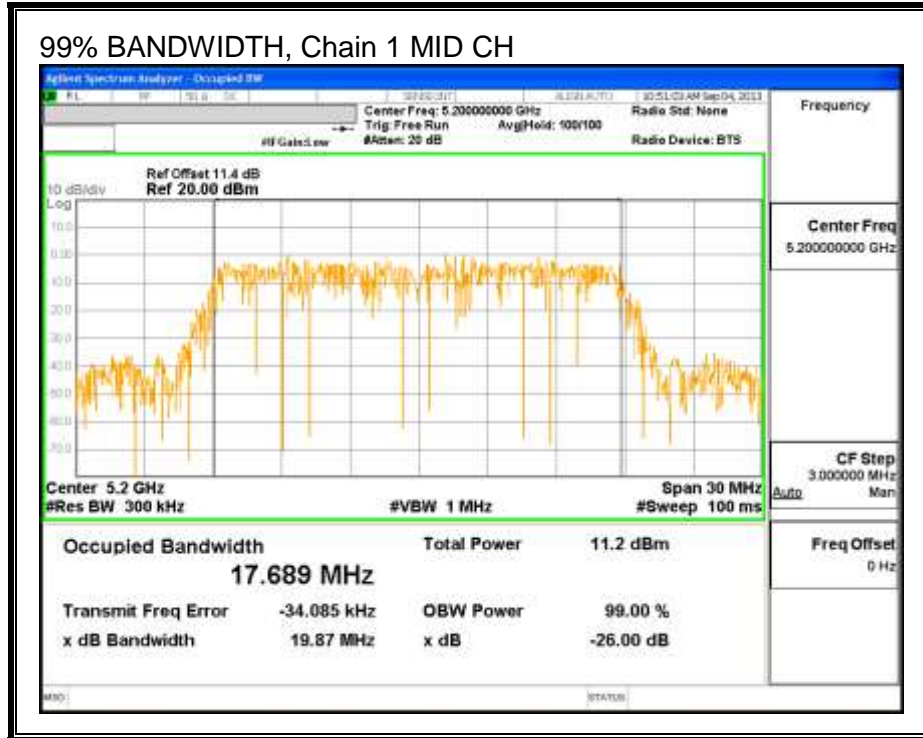

8.3.3. AVERAGE POWER

LIMITS

None; for reporting purposes only.

TEST PROCEDURE

The transmitter output is connected to a power meter.

The cable assembly insertion loss of 11.4 dB (including 10 dB pad and 1.4 dB cable) was entered as an offset in the power meter to allow for direct reading of power.

RESULTS

Average Power Results

Channel	Frequency (MHz)	Chain 0 Power (dBm)	Chain 1 Power (dBm)	Total Power (dBm)
Low	5180	10.99	10.90	13.96
Mid	5200	11.00	11.00	14.01
High	5240	11.00	10.99	14.01

8.3.4. OUTPUT POWER AND PPSD

LIMITS

FCC §15.407 (a) (1)

For the band 5.15–5.25 GHz, the maximum conducted output power over the frequency band of operation shall not exceed the lesser of 50 mW or 4 dBm + 10 log B, where B is the 26–dB emission bandwidth in MHz. In addition, the peak power spectral density shall not exceed 4 dBm in any 1–MHz band. If transmitting antennas of directional gain greater than 6 dBi are used, both the maximum conducted output power and the peak power spectral density shall be reduced by the amount in dB that the directional gain of the antenna exceeds 6 dBi.

IC RSS-210 A9.2 (1)

The maximum e.i.r.p. shall not exceed 200 mW or 10 + 10 log₁₀ B, dBm, whichever power is less. B is the 99% emission bandwidth in MHz. The e.i.r.p. spectral density shall not exceed 10 dBm in any 1.0 MHz band.

DIRECTIONAL ANTENNA GAIN

For output power, the TX chains are uncorrelated and the antenna gain is unequal among the chains. The directional gain is:

Chain 0 Antenna Gain (dBi)	Chain 1 Antenna Gain (dBi)	Uncorrelated Chains Directional Gain (dBi)
2.37	2.07	2.22

For PPSD, the TX chains are correlated and the antenna gain is unequal among the chains. The directional gain is:

Chain 0 Antenna Gain (dBi)	Chain 1 Antenna Gain (dBi)	Correlated Chains Directional Gain (dBi)
2.37	2.07	5.23

RESULTS

Limits

Channel	Frequency (MHz)	FCC Power Limit (dBm)	IC EIRP Limit (dBm)	Max IC Power (dBm)	Power Limit (dBm)	FCC PPSD Limit (dBm)	IC eirp PSD Limit (dBm)	PPSD Limit (dBm)
Low	5180	17.00	22.46	20.24	17.00	4.00	10.00	4.00
Mid	5200	17.00	22.47	20.25	17.00	4.00	10.00	4.00
High	5240	17.00	22.46	20.24	17.00	4.00	10.00	4.00

Duty Cycle CF (dB)	0.00	Included in Calculations of Corr'd Power & PPSD
---------------------------	------	--

Output Power Results

Channel	Frequency (MHz)	Chain 0 Meas Power (dBm)	Chain 1 Meas Power (dBm)	Total Corr'd Power (dBm)	Power Limit (dBm)	Power Margin (dB)
Low	5180	11.16	10.97	14.07	17.00	-2.93
Mid	5200	11.10	11.21	14.16	17.00	-2.84
High	5240	11.14	11.08	14.12	17.00	-2.88

PPSD Results

Channel	Frequency (MHz)	Chain 0 Meas PPSD (dBm)	Chain 1 Meas PPSD (dBm)	Total Corr'd PPSD (dBm)	PPSD Limit (dBm)	PPSD Margin (dB)
Low	5180	0.89	0.66	3.79	4.00	-0.21
Mid	5200	0.73	1.13	3.94	4.00	-0.06
High	5240	0.87	0.83	3.86	4.00	-0.14

OUTPUT POWER AND PPSD, Chain 0

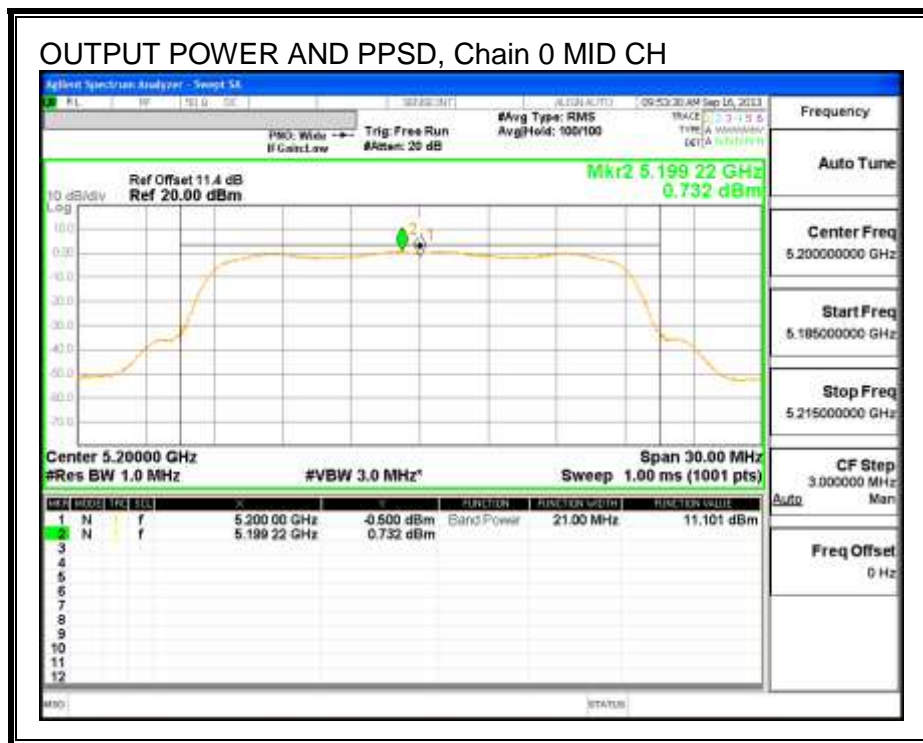
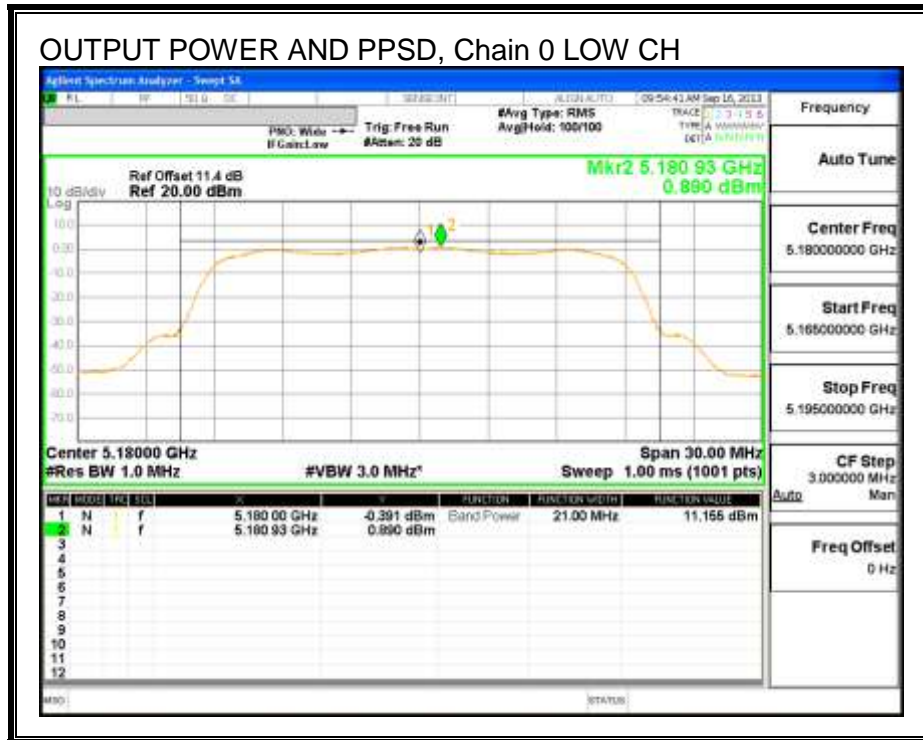

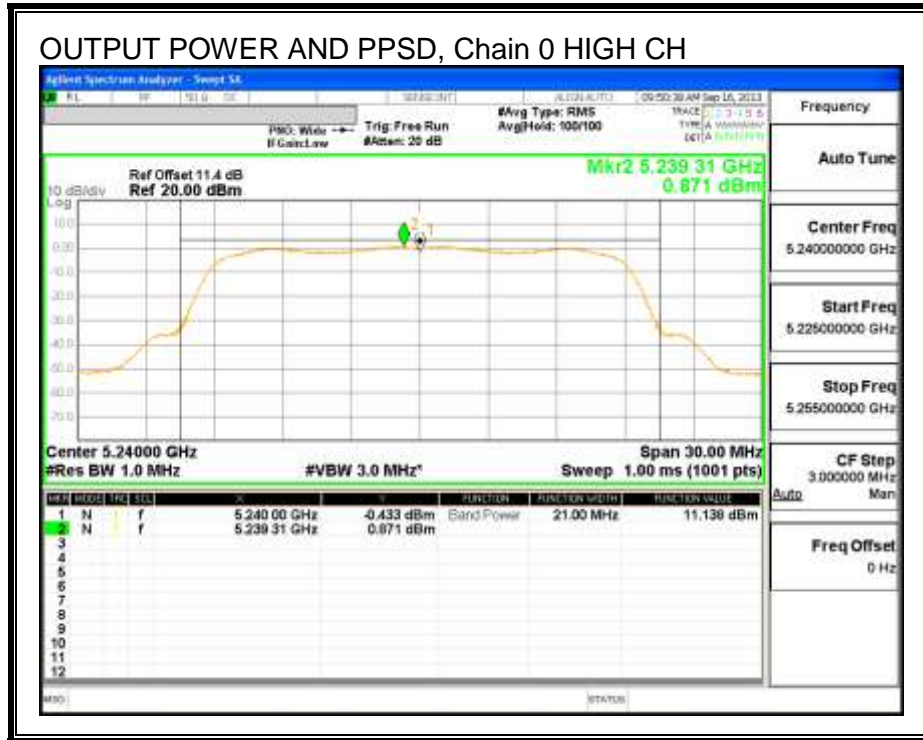

OUTPUT POWER AND PPSD, Chain 1

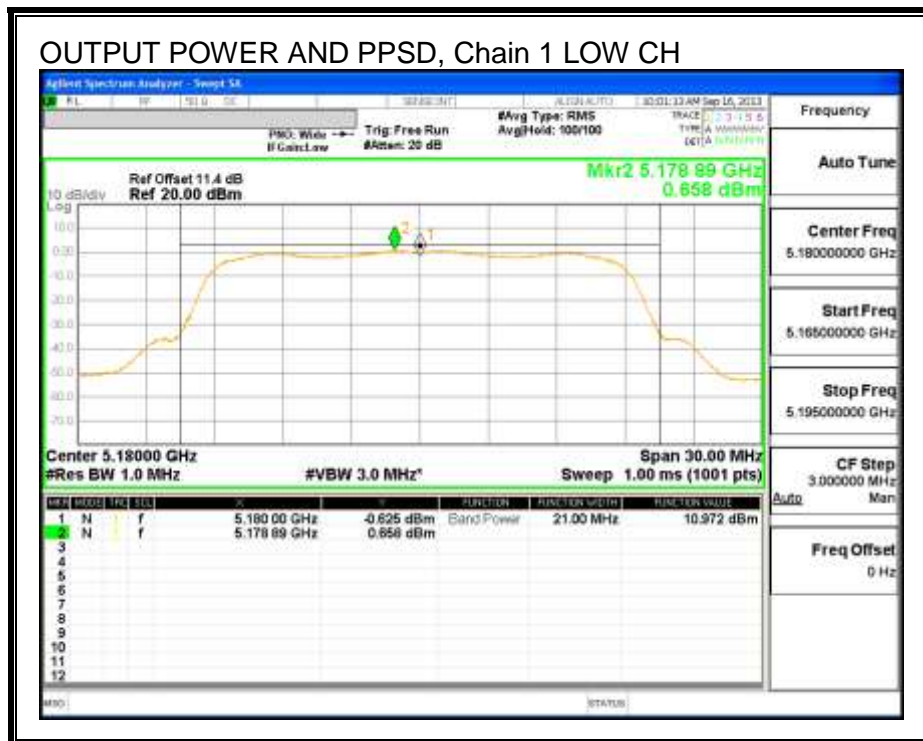

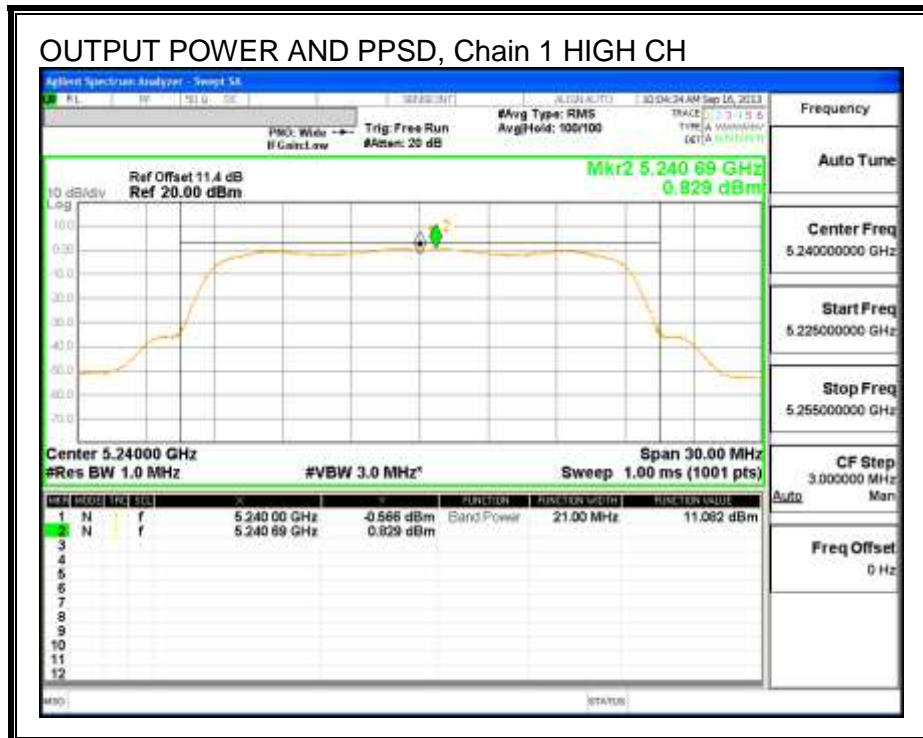
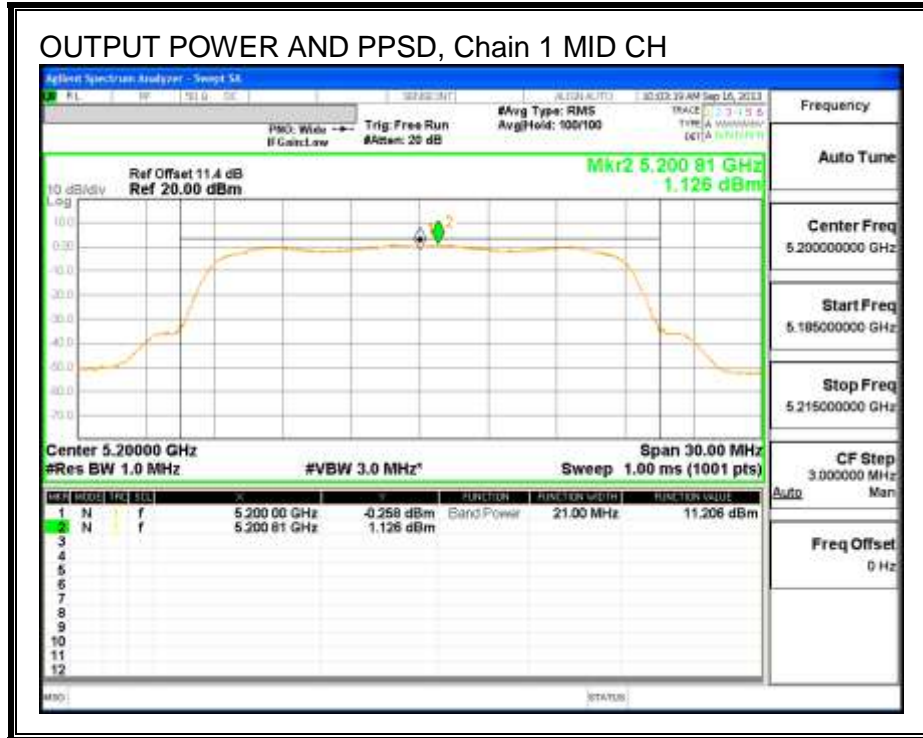

8.4. 802.11n HT40 SISO MODE IN THE 5.2 GHz BAND

8.4.1. 26 dB BANDWIDTH

LIMITS

None; for reporting purposes only.

RESULTS

Channel	Frequency (MHz)	26 dB Bandwidth (MHz)
Low	5190	40.11
High	5230	39.99

26 dB BANDWIDTH

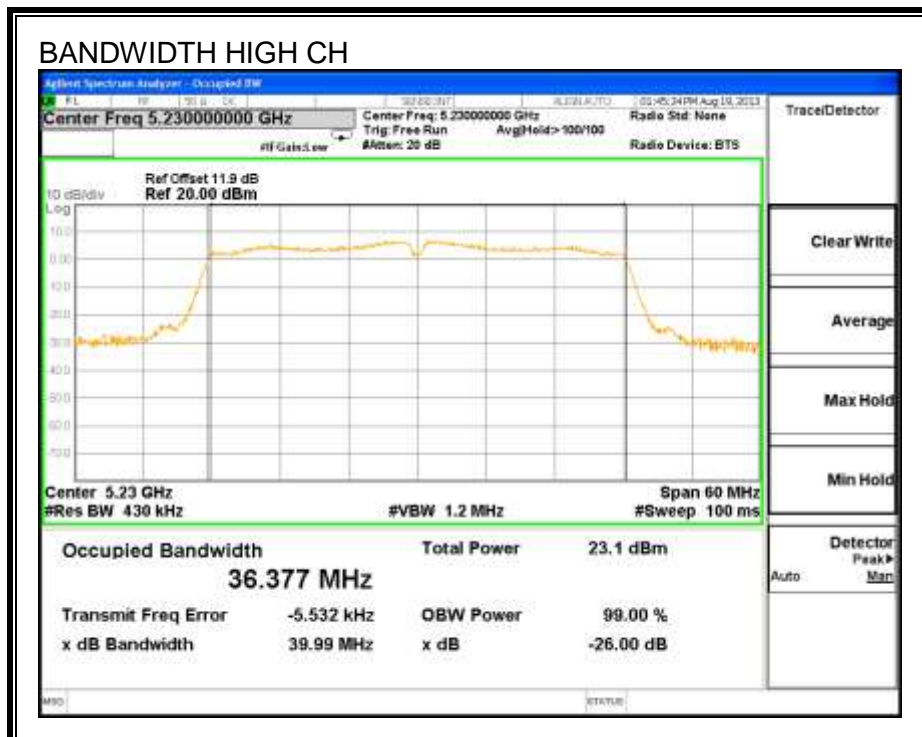
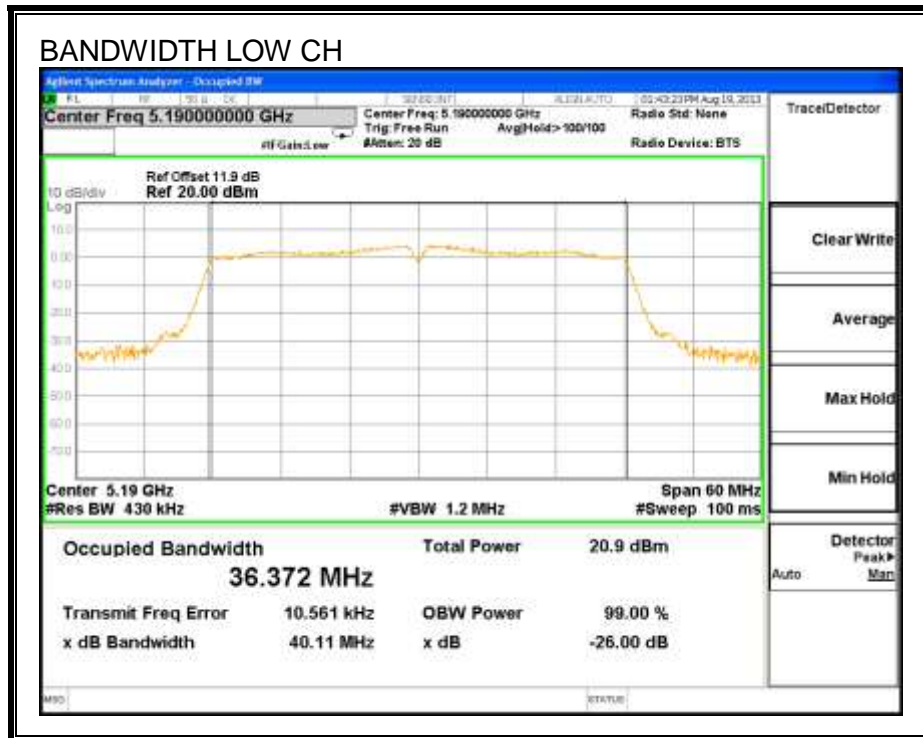

8.4.2. 99% BANDWIDTH

LIMITS

None; for reporting purposes only.

RESULTS

Channel	Frequency (MHz)	99% Bandwidth (MHz)
Low	5190	36.58
High	5230	36.45

99% BANDWIDTH

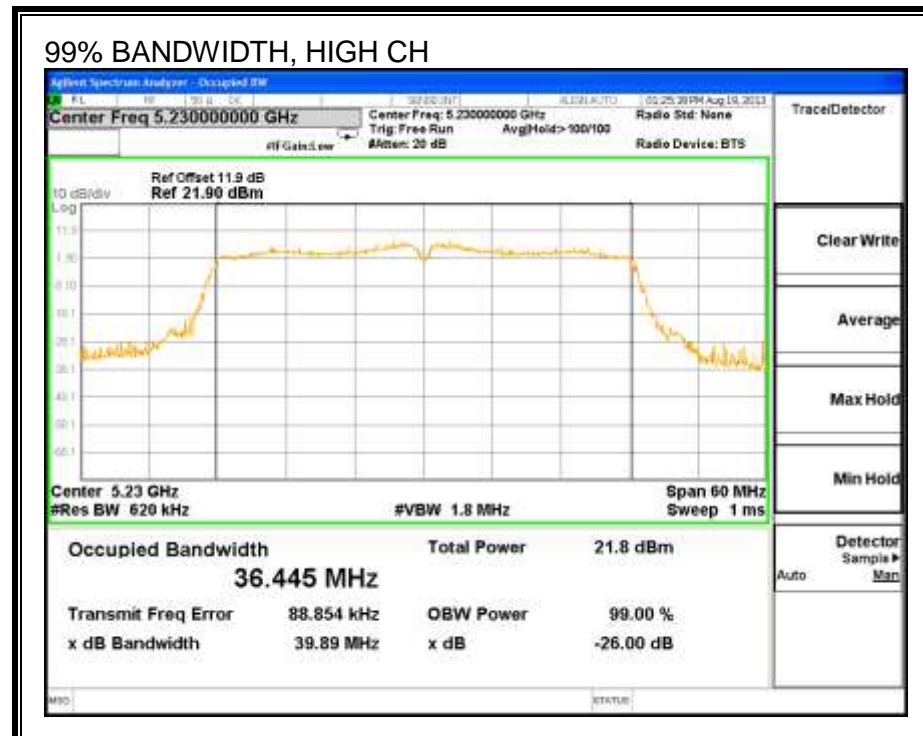
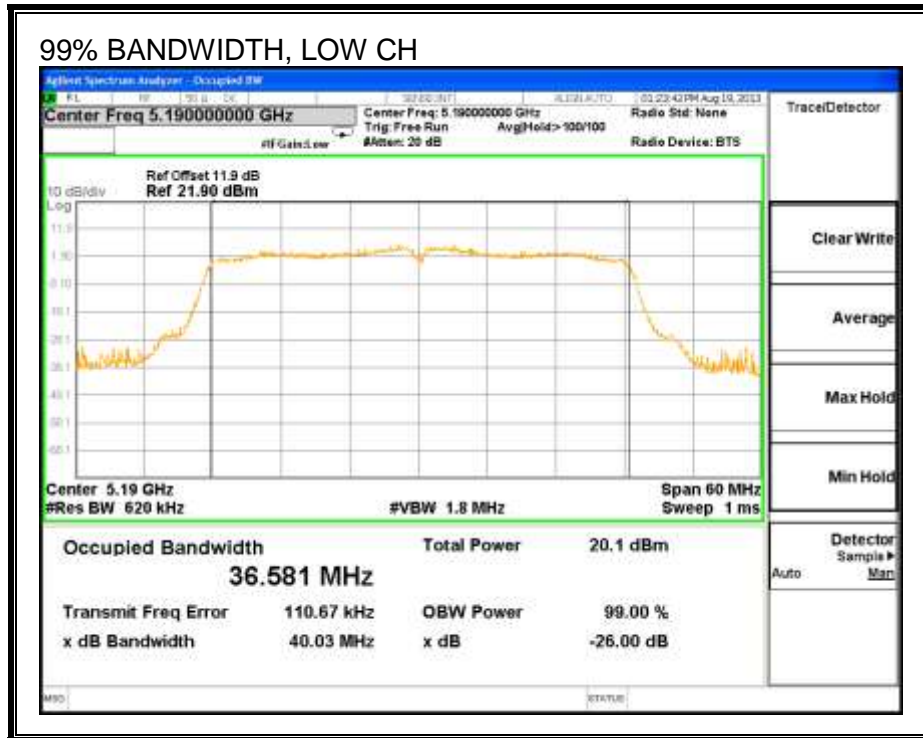

8.4.3. AVERAGE POWER

LIMITS

None; for reporting purposes only.

TEST PROCEDURE

The transmitter output is connected to a power meter.

The cable assembly insertion loss of 11.9 dB (including 10 dB pad and 1.9 dB cable) was entered as an offset in the power meter to allow for direct reading of power.

RESULTS

Channel	Frequency (MHz)	Power (dBm)
Low	5190	12.90
High	5230	15.50

8.4.4. OUTPUT POWER AND PPSD

LIMITS

FCC §15.407 (a) (1)

For the band 5.15–5.25 GHz, the maximum conducted output power over the frequency band of operation shall not exceed the lesser of 50 mW or $4 \text{ dBm} + 10 \log B$, where B is the 26–dB emission bandwidth in MHz. In addition, the peak power spectral density shall not exceed 4 dBm in any 1–MHz band. If transmitting antennas of directional gain greater than 6 dBi are used, both the maximum conducted output power and the peak power spectral density shall be reduced by the amount in dB that the directional gain of the antenna exceeds 6 dBi.

IC RSS-210 A9.2 (1)

The maximum e.i.r.p. shall not exceed 200 mW or $10 + 10 \log_{10} B$, dBm, whichever power is less. B is the 99% emission bandwidth in MHz. The e.i.r.p. spectral density shall not exceed 10 dBm in any 1.0 MHz band.

DIRECTIONAL ANTENNA GAIN

There is only one transmitter output therefore the directional gain is equal to the antenna gain.

RESULTS

Bandwidth and Antenna Gain

Channel	Frequency (MHz)	Min 26 dB BW (MHz)	Min 99% BW (MHz)	Directional Gain (dBi)
Low	5190	40.1	36.6	2.07
High	5230	40.0	36.4	2.07

Limits

Channel	Frequency (MHz)	FCC Power Limit (dBm)	IC EIRP Limit (dBm)	Max IC Power (dBm)	Power Limit (dBm)	FCC PPSD Limit (dBm)	IC eirp PSD Limit (dBm)	PPSD Limit (dBm)
Low	5190	17.00	23.00	20.93	17.00	4.00	10.00	4.00
High	5230	17.00	23.00	20.93	17.00	4.00	10.00	4.00

Duty Cycle CF (dB)	0.00	Included in Calculations of Corr'd Power & PPSD
---------------------------	------	--

Output Power Results

Channel	Frequency (MHz)	Chain 0 Meas Power (dBm)	Total Corr'd Power (dBm)	Power Limit (dBm)	Power Margin (dB)
Low	5190	13.02	13.02	17.00	-3.98
High	5230	15.54	15.54	17.00	-1.46

PPSD Results

Channel	Frequency (MHz)	Chain 0 Meas PPSD (dBm)	Total Corr'd PPSD (dBm)	PPSD Limit (dBm)	PPSD Margin (dB)
Low	5190	0.29	0.29	4.00	-3.71
High	5230	2.58	2.58	4.00	-1.42

OUTPUT POWER AND PPSD, Chain 0

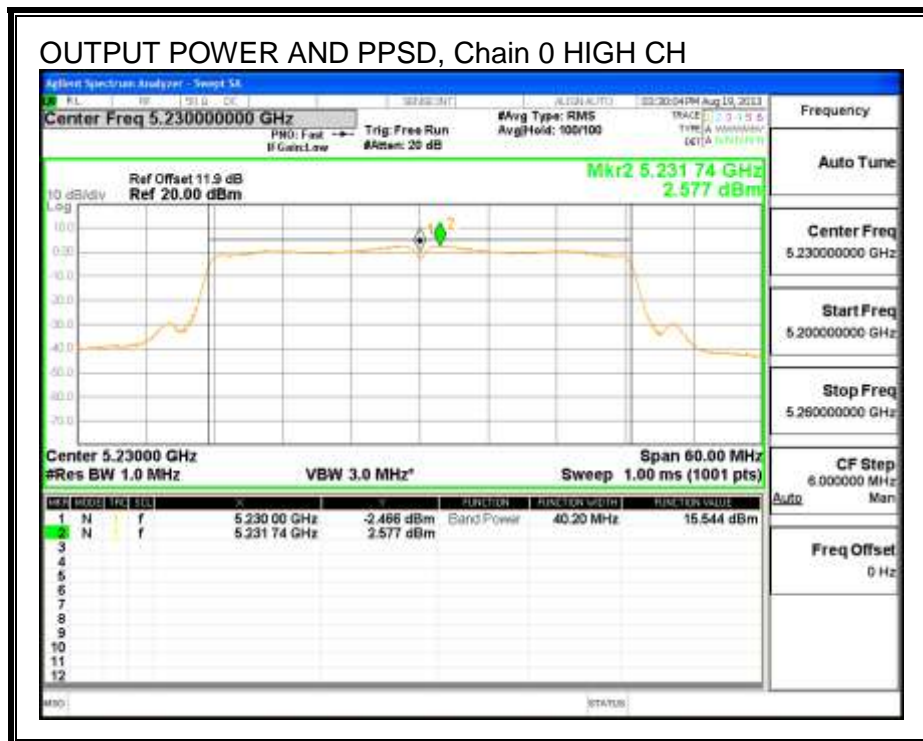
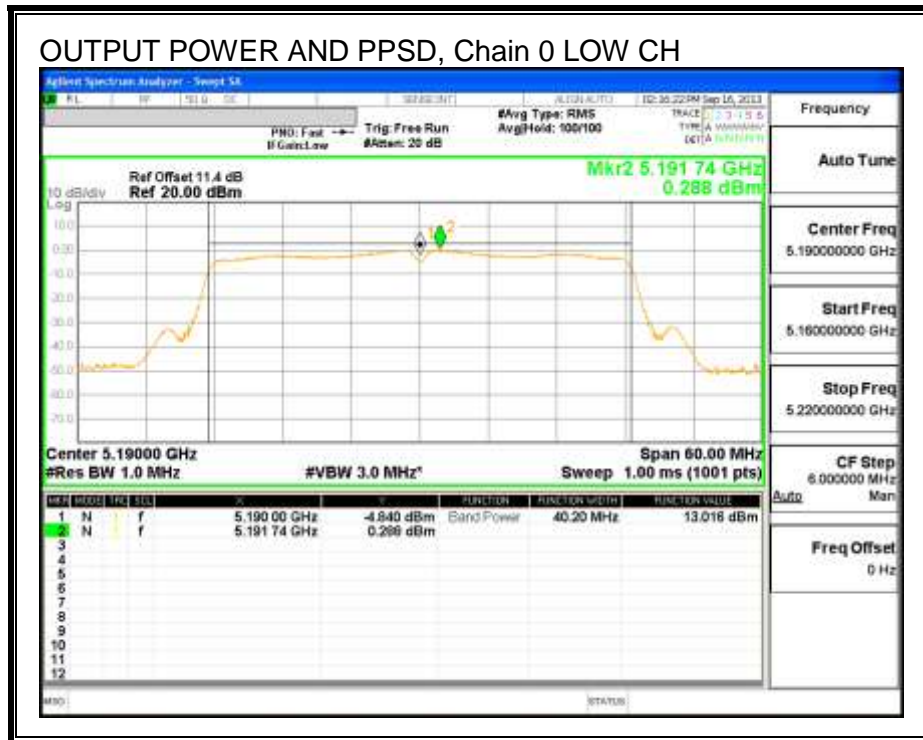

8.5. 802.11n HT40 2TX CDD MODE IN THE 5.2 GHZ BAND

8.5.1. 26 dB BANDWIDTH

LIMITS

None; for reporting purposes only.

RESULTS

Channel	Frequency (MHz)	26 dB BW Chain 0 (MHz)	26 dB BW Chain 1 (MHz)
Low	5190	40.04	39.51
High	5230	40.15	39.51

26 dB BANDWIDTH, Chain 0

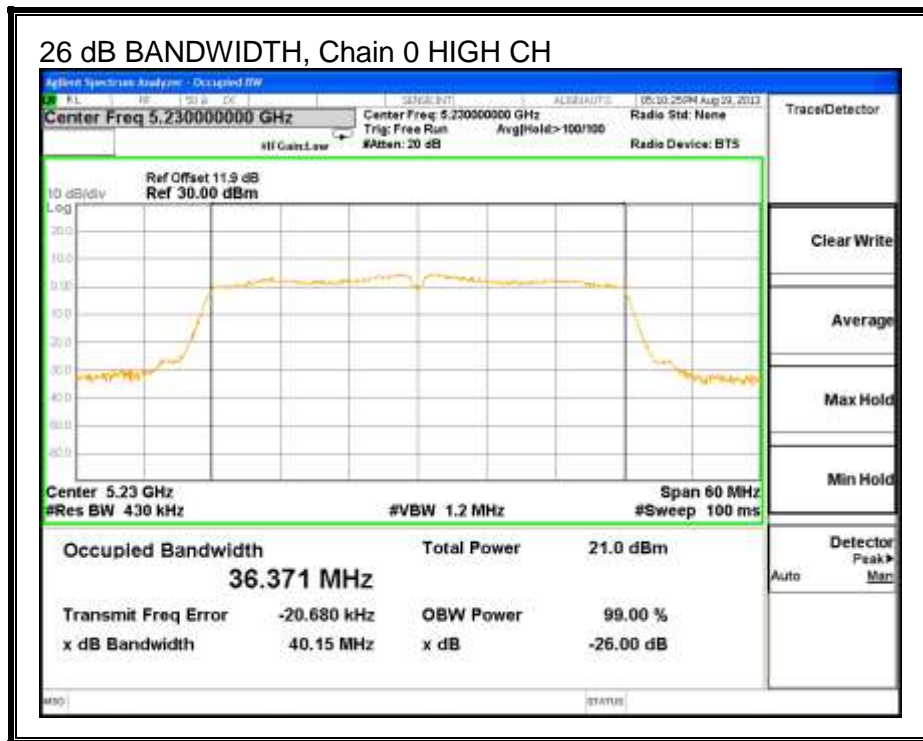
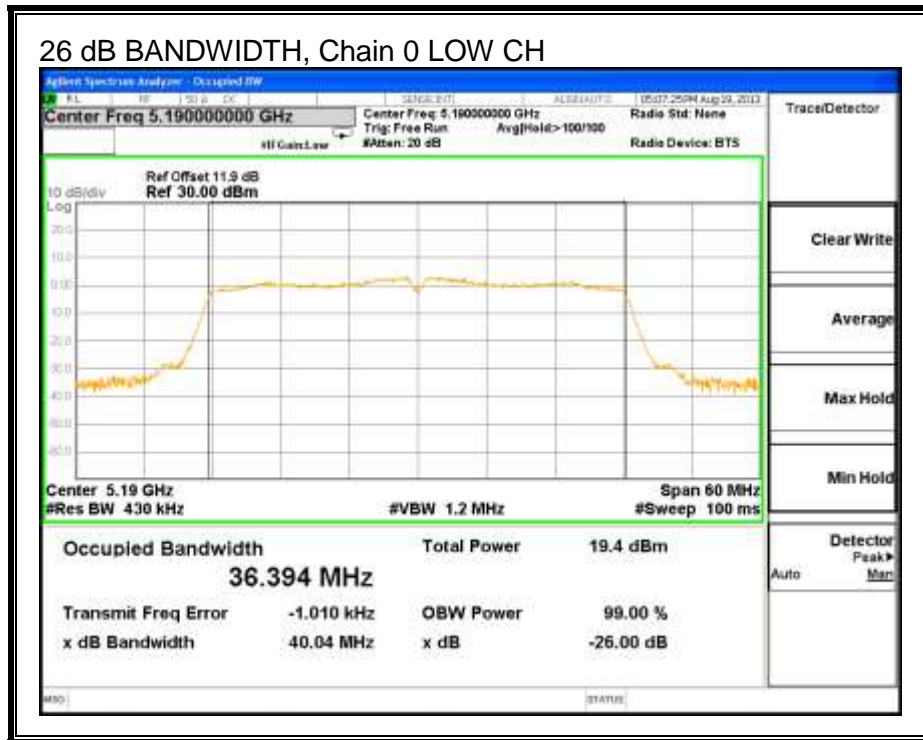

26 dB BANDWIDTH, Chain 1

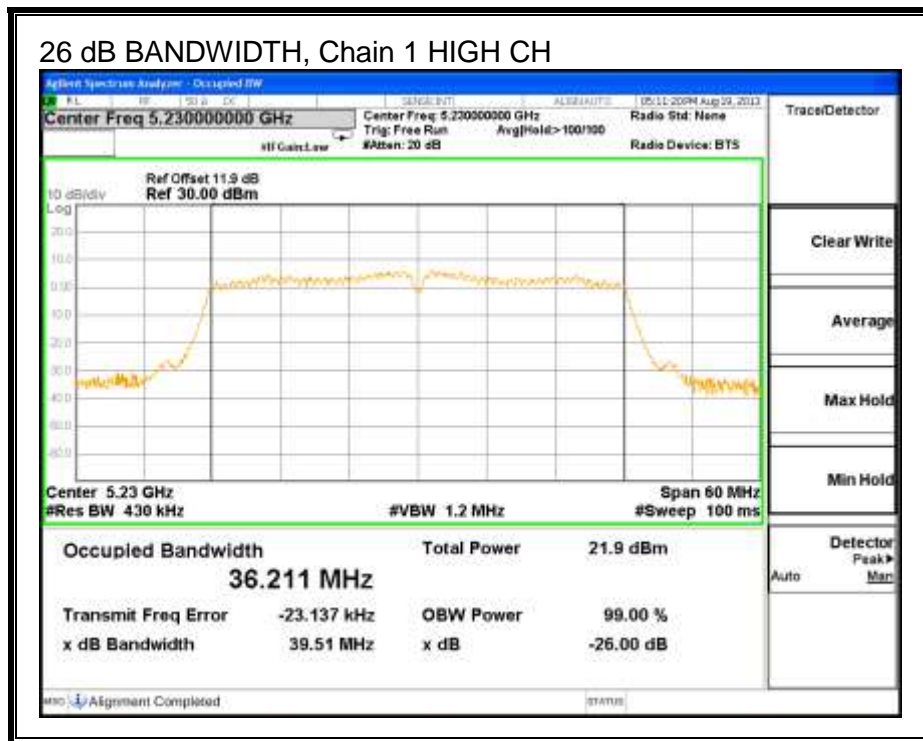
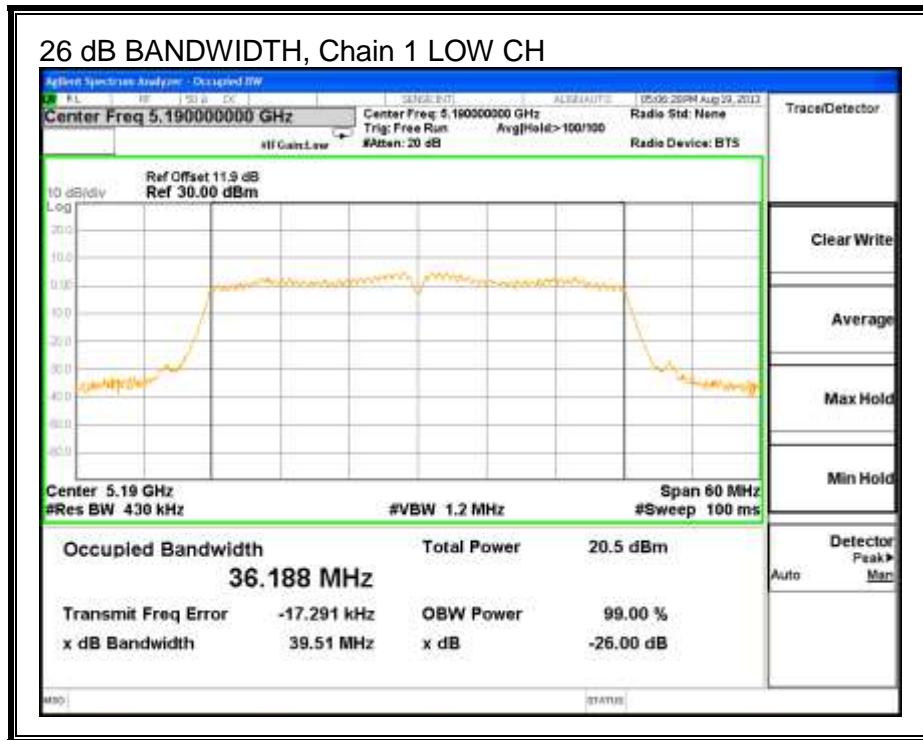

8.5.2. 99% BANDWIDTH

LIMITS

None; for reporting purposes only.

RESULTS

Channel	Frequency (MHz)	99% BW Chain 0 (MHz)	99% BW Chain 1 (MHz)
Low	5190	36.32	36.26
High	5230	36.31	36.28

99% BANDWIDTH, Chain 0

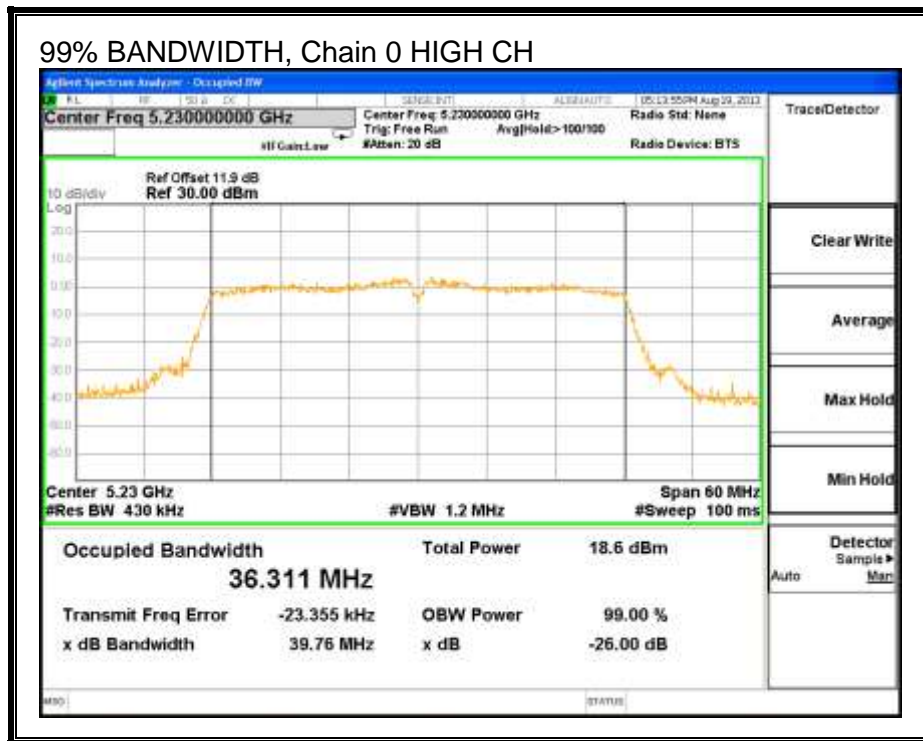
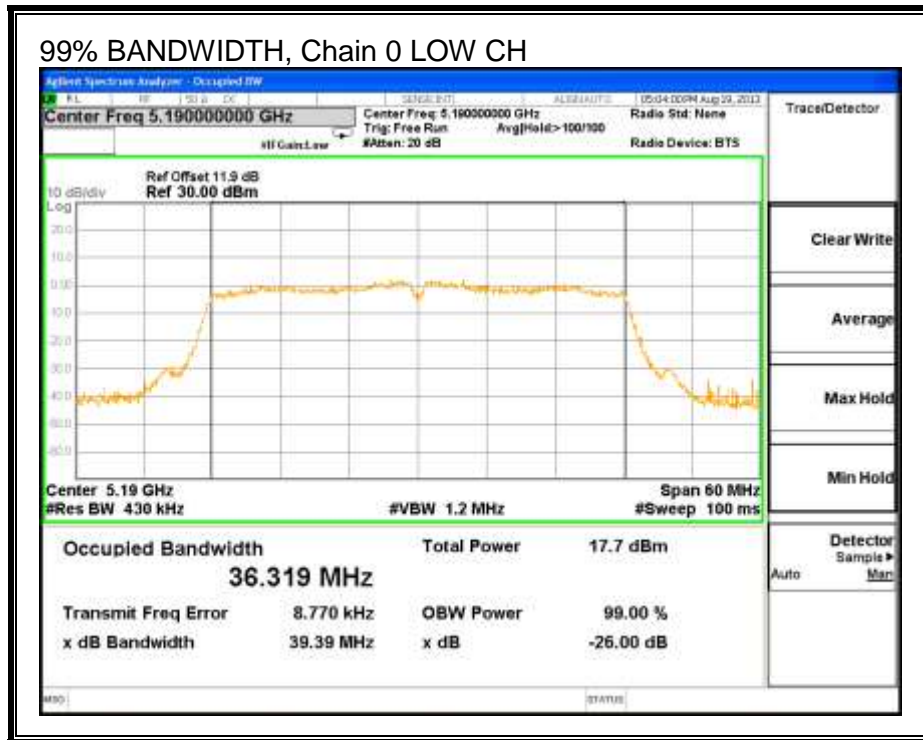

99% BANDWIDTH, Chain 1

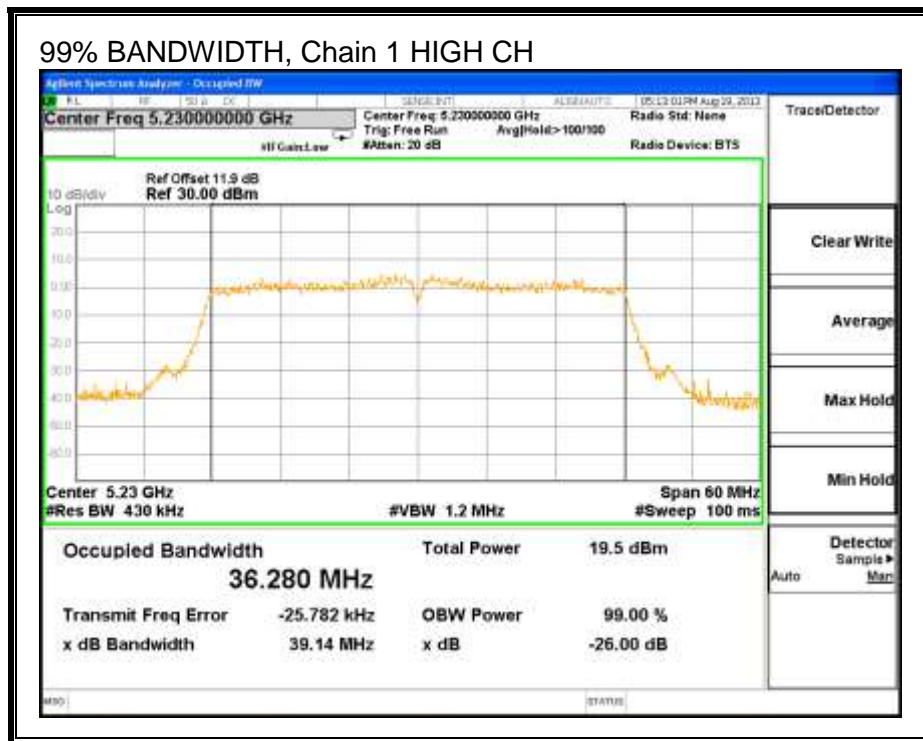
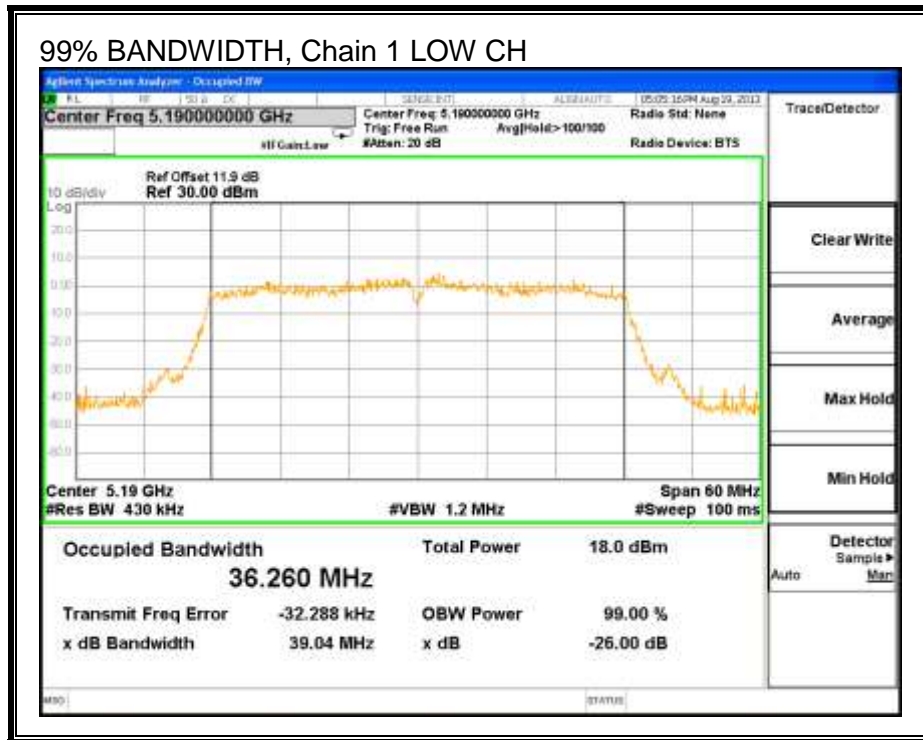

8.5.3. AVERAGE POWER

LIMITS

None; for reporting purposes only.

TEST PROCEDURE

The transmitter output is connected to a power meter.

The cable assembly insertion loss of 11.9 dB (including 10 dB pad and 1.9 dB cable) was entered as an offset in the power meter to allow for direct reading of power.

RESULTS

Average Power Results

Channel	Frequency (MHz)	Chain 0 Power (dBm)	Chain 1 Power (dBm)	Total Power (dBm)
Low	5190	11.00	10.78	13.90
High	5230	13.00	12.62	15.82

8.5.4. OUTPUT POWER AND PPSD

LIMITS

FCC §15.407 (a) (1)

For the band 5.15–5.25 GHz, the maximum conducted output power over the frequency band of operation shall not exceed the lesser of 50 mW or 4 dBm + 10 log B, where B is the 26–dB emission bandwidth in MHz. In addition, the peak power spectral density shall not exceed 4 dBm in any 1–MHz band. If transmitting antennas of directional gain greater than 6 dBi are used, both the maximum conducted output power and the peak power spectral density shall be reduced by the amount in dB that the directional gain of the antenna exceeds 6 dBi.

IC RSS-210 A9.2 (1)

The maximum e.i.r.p. shall not exceed 200 mW or 10 + 10 log₁₀ B, dBm, whichever power is less. B is the 99% emission bandwidth in MHz. The e.i.r.p. spectral density shall not exceed 10 dBm in any 1.0 MHz band.

DIRECTIONAL ANTENNA GAIN

For output power, the TX chains are uncorrelated and the antenna gain is unequal among the chains. The directional gain is:

Chain 0 Antenna Gain (dBi)	Chain 1 Antenna Gain (dBi)	Uncorrelated Chains Directional Gain (dBi)
2.37	2.07	2.22

For PPSD, the TX chains are correlated and the antenna gain is unequal among the chains. The directional gain is:

Chain 0 Antenna Gain (dBi)	Chain 1 Antenna Gain (dBi)	Correlated Chains Directional Gain (dBi)
2.37	2.07	5.23

RESULTS

Bandwidth and Antenna Gain

Channel	Frequency (MHz)	Min 26 dB BW (MHz)	Min 99% BW (MHz)	Uncorrelat Directional Gain (dBi)	Correlat Directional Gain (dBi)
Low	5190	39.5	36.3	2.22	5.23
High	5230	39.5	36.3	2.22	5.23

Limits

Channel	Frequency (MHz)	FCC Power Limit (dBm)	IC EIRP Limit (dBm)	Max IC Power (dBm)	Power Limit (dBm)	FCC PPSD Limit (dBm)	IC eirp PSD Limit (dBm)	PPSD Limit (dBm)
Low	5190	17.00	23.00	20.78	17.00	4.00	10.00	4.00
High	5230	17.00	23.00	20.78	17.00	4.00	10.00	4.00

Duty Cycle CF (dB)	0.00	Included in Calculations of Corr'd Power & PPSD
---------------------------	------	--

Output Power Results

Channel	Frequency (MHz)	Chain 0 Meas Power (dBm)	Chain 1 Meas Power (dBm)	Total Corr'd Power (dBm)	Power Limit (dBm)	Power Margin (dB)
Low	5190	11.21	10.95	14.10	17.00	-2.90
High	5230	13.25	12.85	16.07	17.00	-0.93

PPSD Results

Channel	Frequency (MHz)	Chain 0 Meas PPSD (dBm)	Chain 1 Meas PPSD (dBm)	Total Corr'd PPSD (dBm)	PPSD Limit (dBm)	PPSD Margin (dB)
Low	5190	-1.83	-1.64	1.28	4.00	-2.72
High	5230	0.28	0.05	3.18	4.00	-0.82

OUTPUT POWER AND PPSD, Chain 0

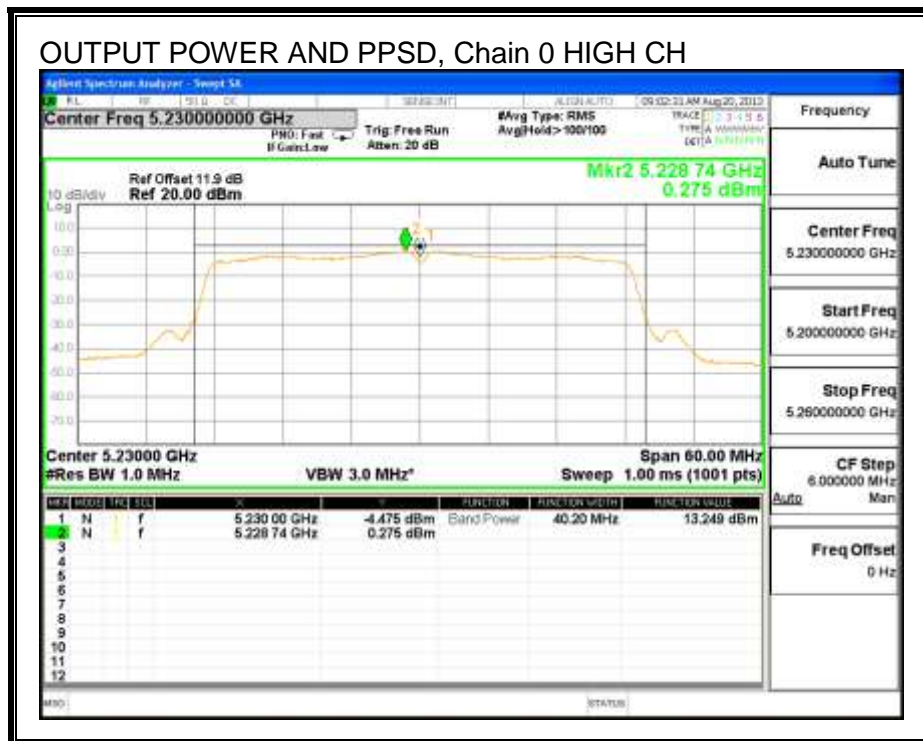
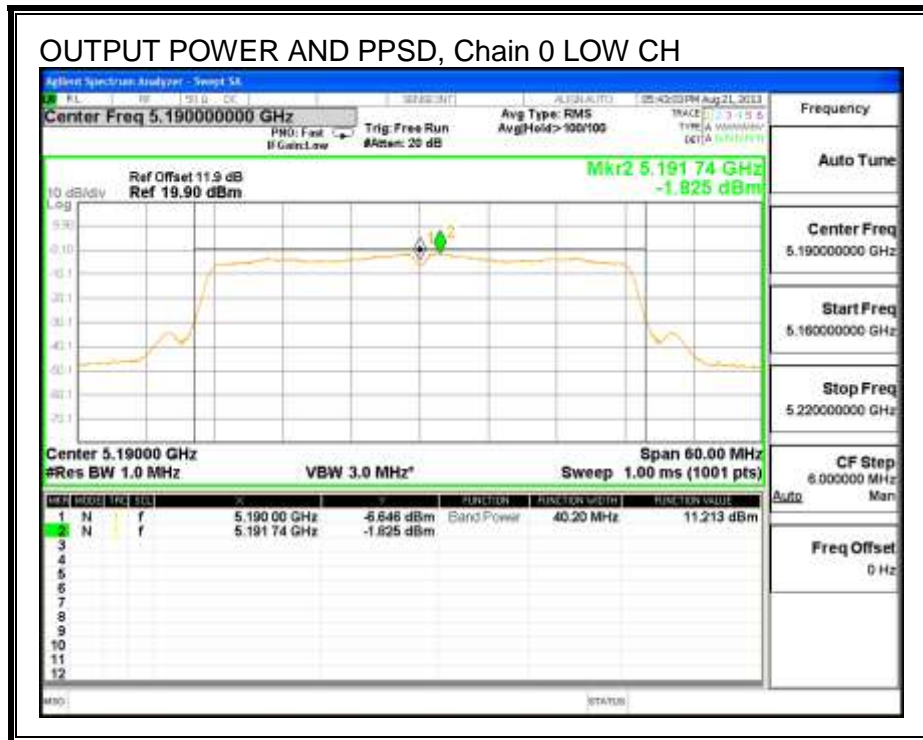

OUTPUT POWER AND PPSD, Chain 1

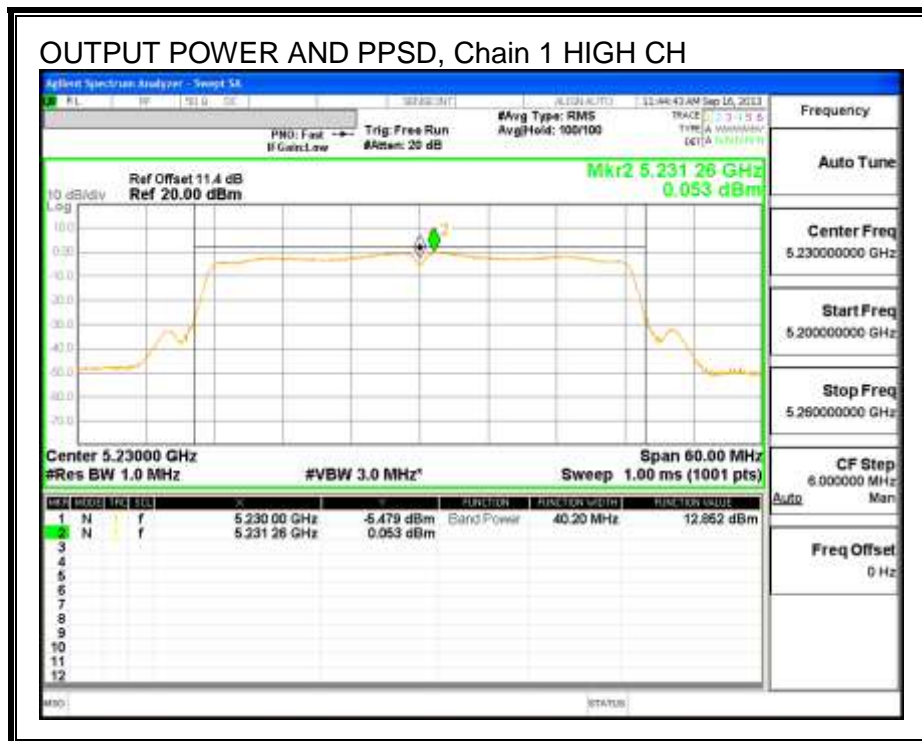
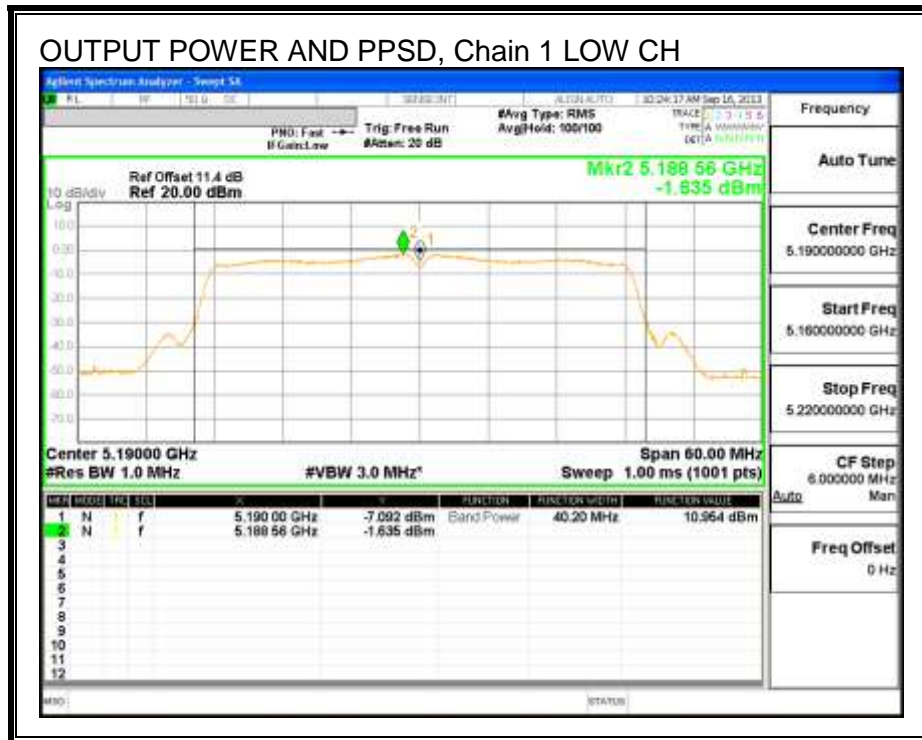

8.6. 802.11n HT40 2TX STBC MODE IN THE 5.2 GHz BAND

8.6.1. 26 dB BANDWIDTH

LIMITS

None; for reporting purposes only.

RESULTS

Channel	Frequency (MHz)	26 dB BW Chain 0 (MHz)	26 dB BW Chain 1 (MHz)
High	5230	40.20	39.66

26 dB BANDWIDTH, Chain 0

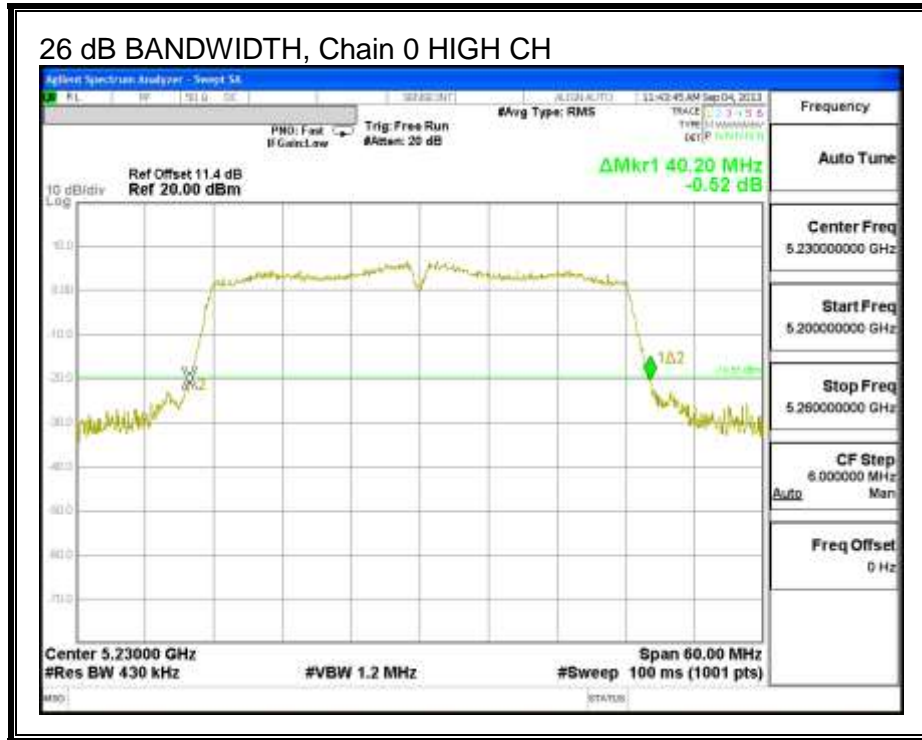

26 dB BANDWIDTH, Chain 1

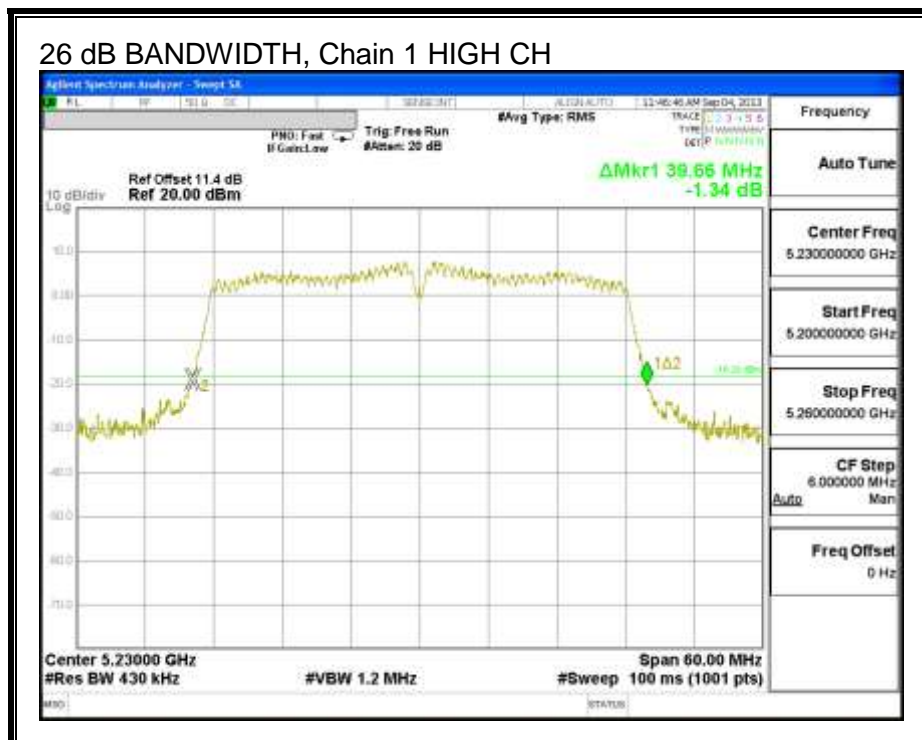

8.6.2. 99% BANDWIDTH

LIMITS

None; for reporting purposes only.

RESULTS

Channel	Frequency (MHz)	99% BW Chain 0 (MHz)	99% BW Chain 1 (MHz)
High	5230	36.6590	36.4090

99% BANDWIDTH, Chain 0

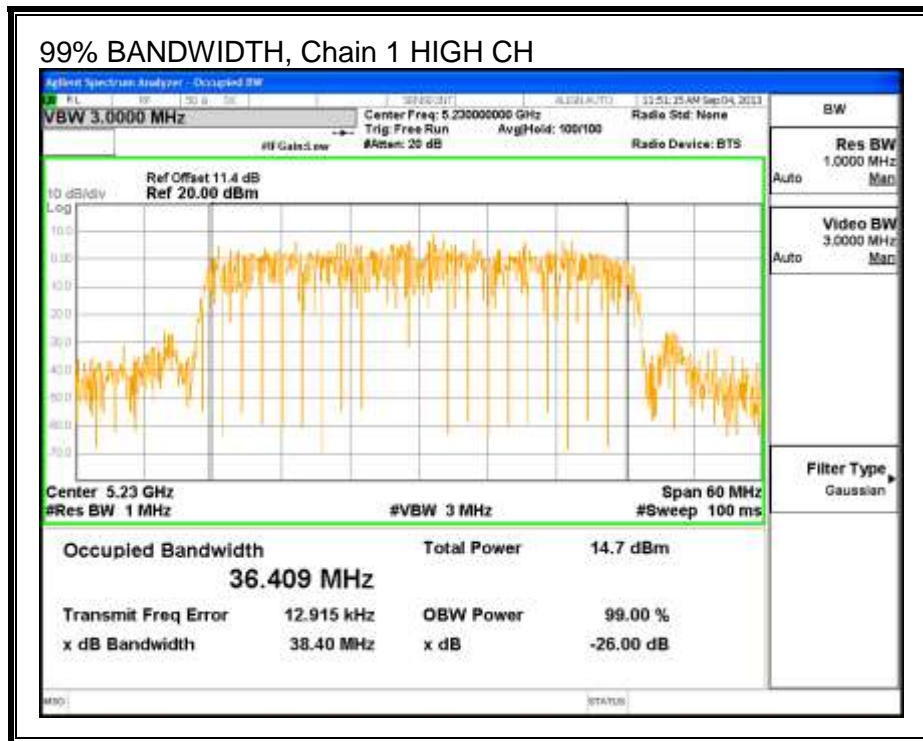
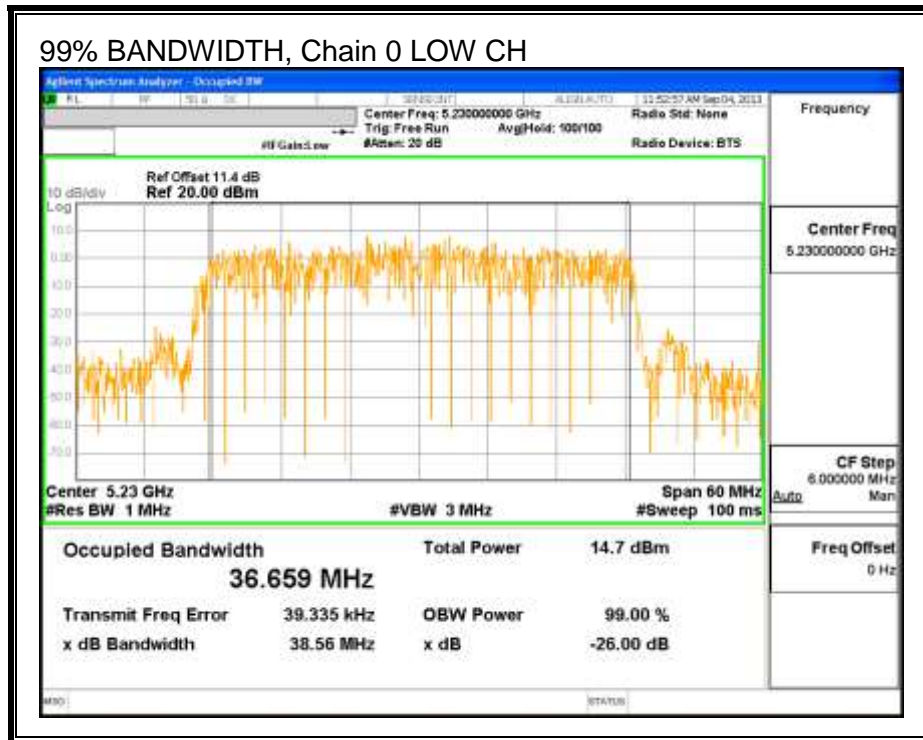

8.6.3. AVERAGE POWER

LIMITS

None; for reporting purposes only.

TEST PROCEDURE

The transmitter output is connected to a power meter.

The cable assembly insertion loss of 11.4 dB (including 10 dB pad and 1.4 dB cable) was entered as an offset in the power meter to allow for direct reading of power.

RESULTS

Average Power Results

Channel	Frequency (MHz)	Chain 0 Power (dBm)	Chain 1 Power (dBm)	Total Power (dBm)
High	5230	13.50	13.48	16.50

8.6.4. OUTPUT POWER AND PPSD

LIMITS

FCC §15.407 (a) (1)

For the band 5.15–5.25 GHz, the maximum conducted output power over the frequency band of operation shall not exceed the lesser of 50 mW or 4 dBm + 10 log B, where B is the 26–dB emission bandwidth in MHz. In addition, the peak power spectral density shall not exceed 4 dBm in any 1–MHz band. If transmitting antennas of directional gain greater than 6 dBi are used, both the maximum conducted output power and the peak power spectral density shall be reduced by the amount in dB that the directional gain of the antenna exceeds 6 dBi.

IC RSS-210 A9.2 (1)

The maximum e.i.r.p. shall not exceed 200 mW or 10 + 10 log₁₀ B, dBm, whichever power is less. B is the 99% emission bandwidth in MHz. The e.i.r.p. spectral density shall not exceed 10 dBm in any 1.0 MHz band.

DIRECTIONAL ANTENNA GAIN

For output power, the TX chains are uncorrelated and the antenna gain is unequal among the chains. The directional gain is:

Chain 0 Antenna Gain (dBi)	Chain 1 Antenna Gain (dBi)	Uncorrelated Chains Directional Gain (dBi)
2.37	2.07	2.22

For PPSD, the TX chains are correlated and the antenna gain is unequal among the chains. The directional gain is:

Chain 0 Antenna Gain (dBi)	Chain 1 Antenna Gain (dBi)	Correlated Chains Directional Gain (dBi)
2.37	2.07	5.23

RESULTS

Bandwidth and Antenna Gain

Channel	Frequency (MHz)	Min 26 dB BW (MHz)	Min 99% BW (MHz)	Uncorrelat Directional Gain (dBi)	Correlat Directio nal Gain (dBi)
High	5230	40.20	36.6590	2.22	5.23

Limits

Channel	Frequency (MHz)	FCC Power Limit (dBm)	IC EIRP Limit (dBm)	Max IC Power (dBm)	Power Limit (dBm)	FCC PPSD Limit (dBm)	IC eirp PSD Limit (dBm)	PPSD Limit (dBm)
High	5230	17.00	23.00	20.78	17.00	4.00	10.00	4.00

Duty Cycle CF (dB)	0.00	Included in Calculations of Corr'd Power & PPSD
---------------------------	------	--

Output Power Results

Channel	Frequency (MHz)	Chain 0 Meas Power (dBm)	Chain 1 Meas Power (dBm)	Total Corr'd Power (dBm)	Power Limit (dBm)	Power Margin (dB)
High	5230	13.54	13.58	16.57	17.00	-0.43

PPSD Results

Channel	Frequency (MHz)	Chain 0 Meas PPSD (dBm)	Chain 1 Meas PPSD (dBm)	Total Corr'd PPSD (dBm)	PPSD Limit (dBm)	PPSD Margin (dB)
High	5230	0.76	0.87	3.83	4.00	-0.17

OUTPUT POWER AND PPSD, Chain 0

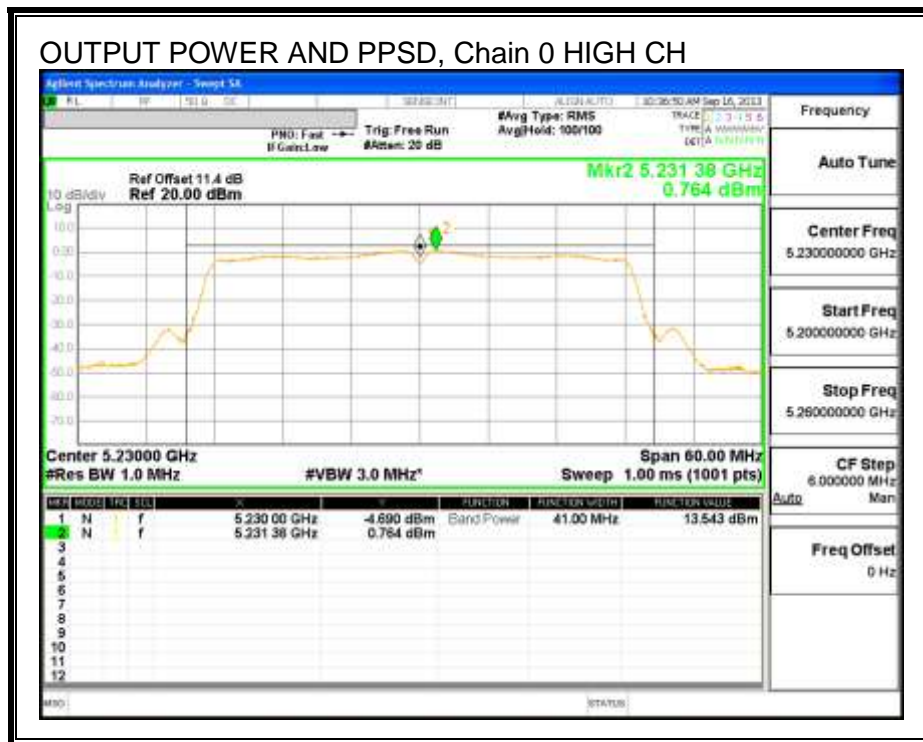

OUTPUT POWER AND PPSD, Chain 1

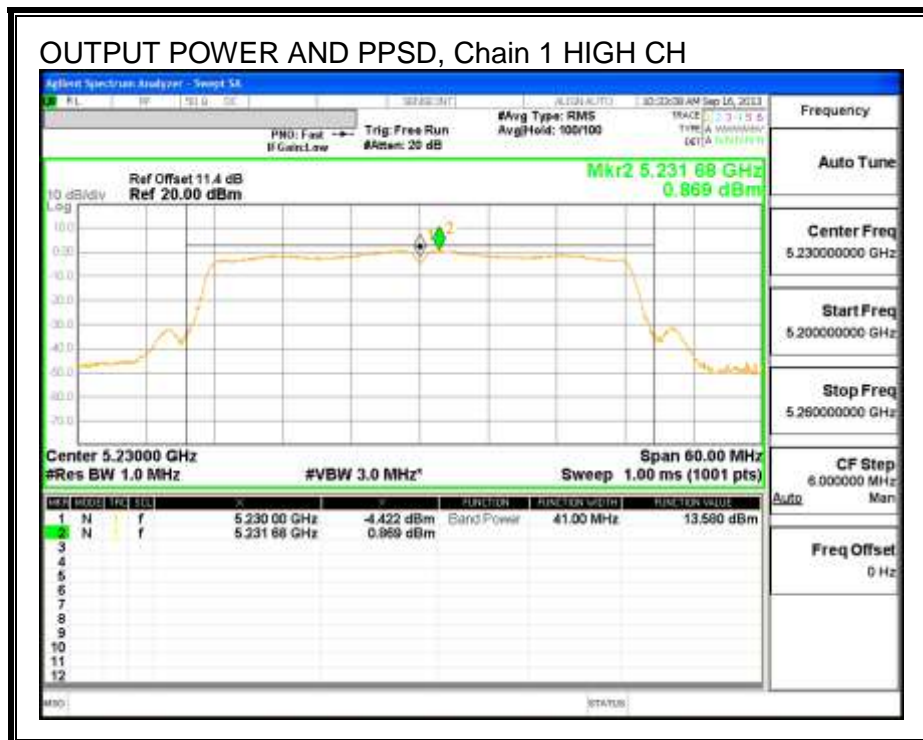

8.7. 802.11a SISO MODE IN THE 5.3 GHz BAND

8.7.1. 26 dB BANDWIDTH

LIMITS

None; for reporting purposes only.

RESULTS

Channel	Frequency (MHz)	26 dB Bandwidth (MHz)
Low	5260	19.22
Mid	5300	19.14
High	5320	19.46

26 dB BANDWIDTH

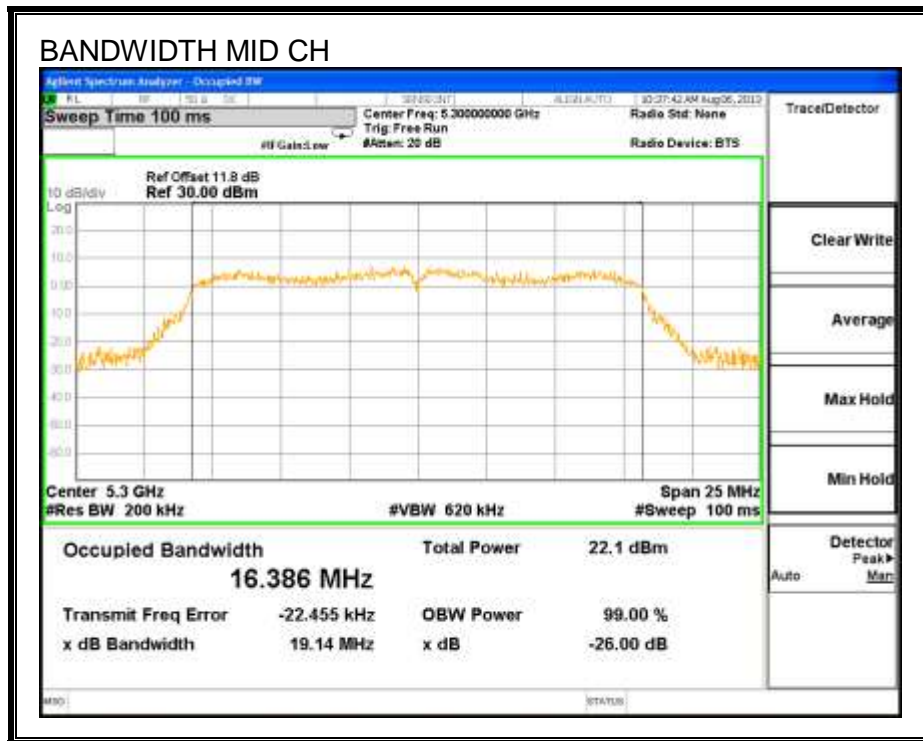
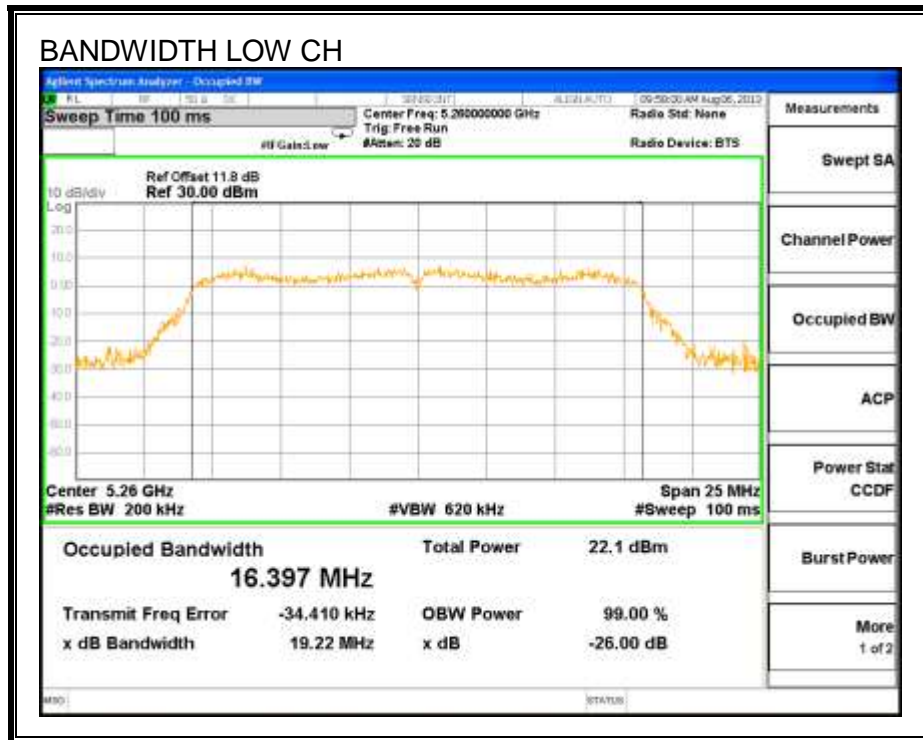

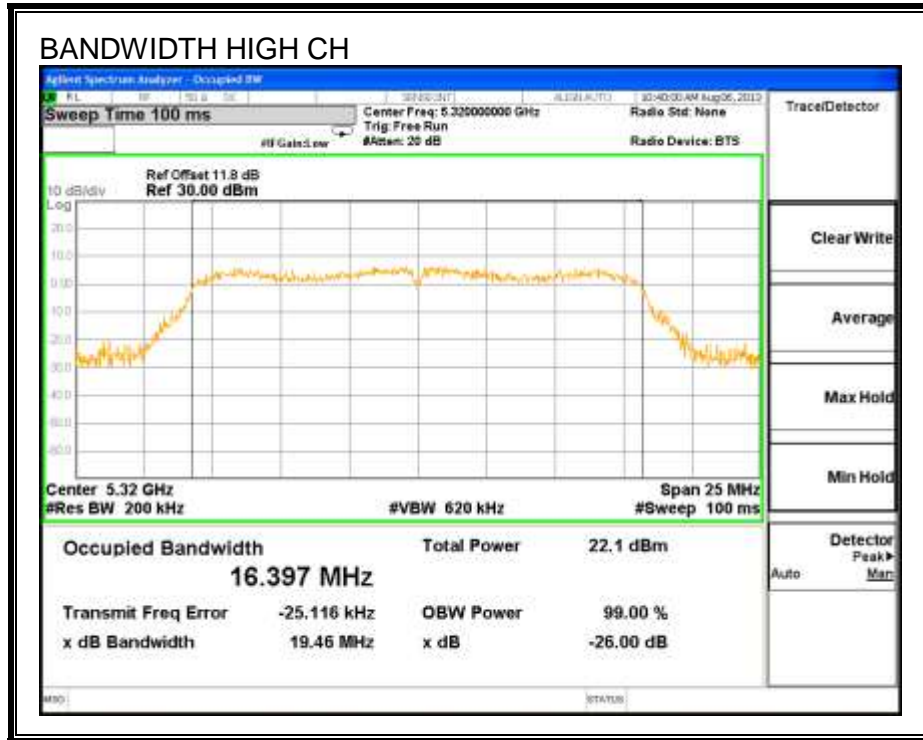

8.7.2. 99% BANDWIDTH

LIMITS

None; for reporting purposes only.

RESULTS

Channel	Frequency (MHz)	99% Bandwidth (MHz)
Low	5260	16.73
Mid	5300	16.41
High	5320	16.42

99% BANDWIDTH

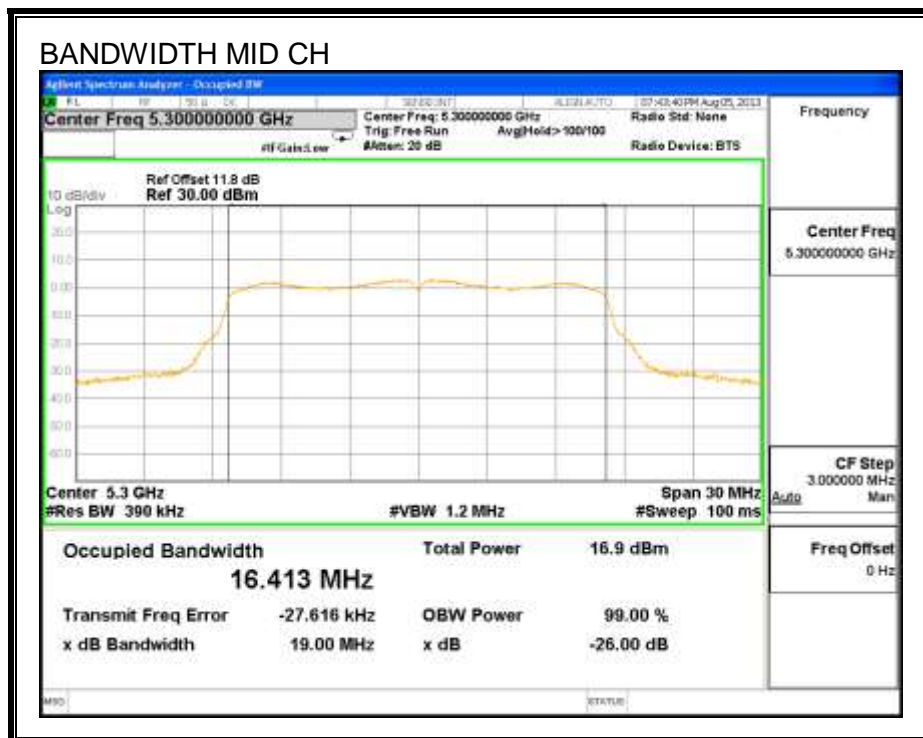
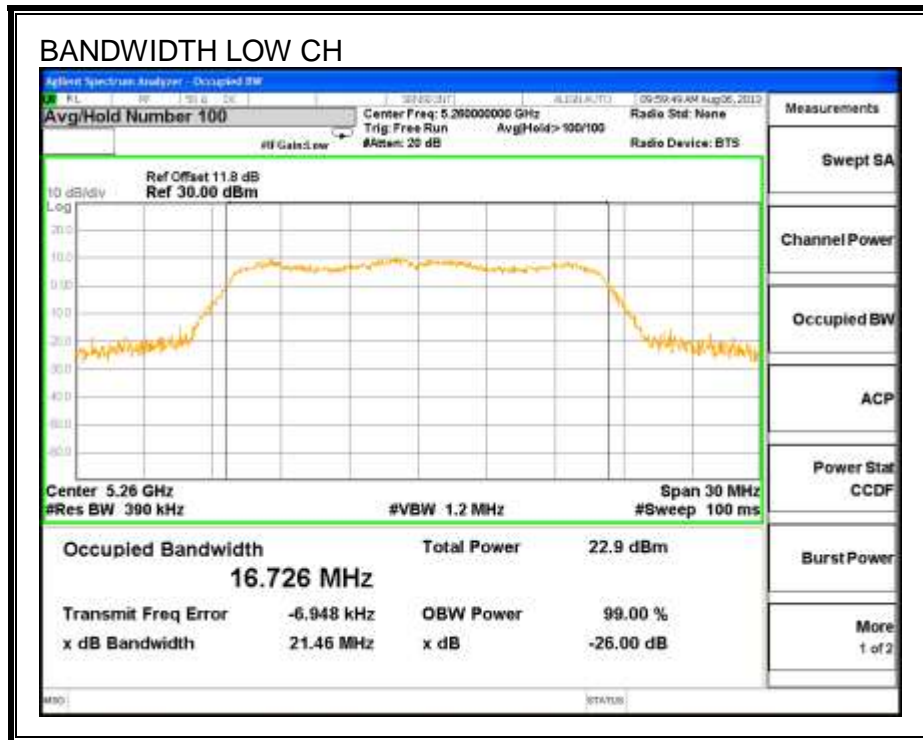

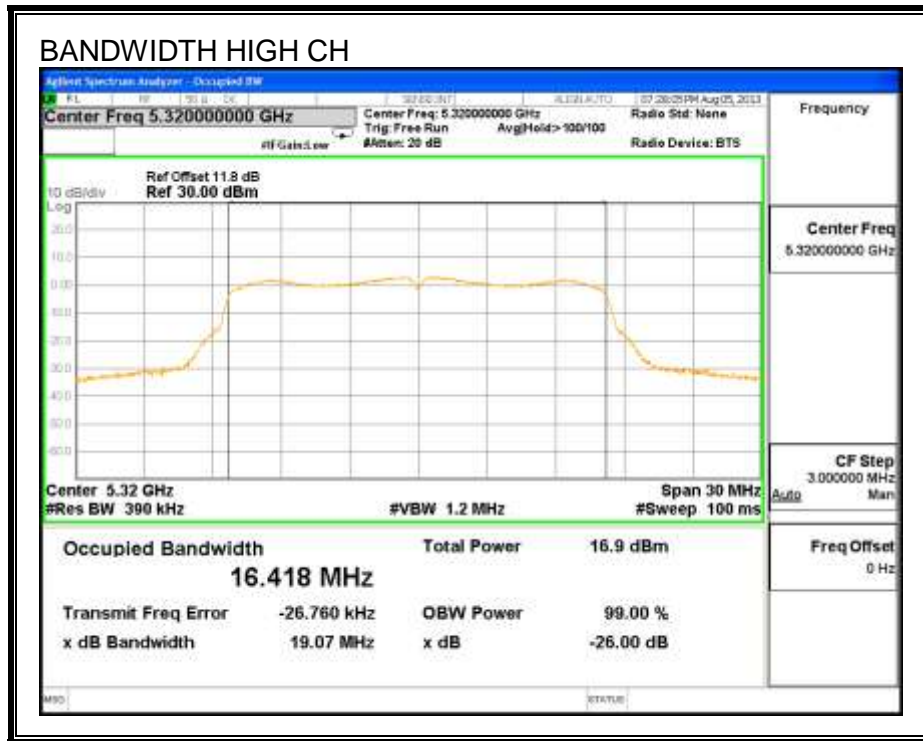

8.7.3. AVERAGE POWER

LIMITS

None; for reporting purposes only.

TEST PROCEDURE

The transmitter output is connected to a power meter.

The cable assembly insertion loss of 11.9 dB (including 10 dB pad and 1.9 dB cable) was entered as an offset in the power meter to allow for direct reading of power.

RESULTS

Channel	Frequency (MHz)	Power (dBm)
Low	5260	16.4
Mid	5300	16.5
High	5320	15.0

8.7.4. OUTPUT POWER AND PPSD

LIMITS

FCC §15.407 (a) (1)

For the band 5.25–5.35 GHz, the maximum conducted output power over the frequency band of operation shall not exceed the lesser of 250 mW or $11 \text{ dBm} + 10 \log B$, where B is the 26–dB emission bandwidth in MHz. In addition, the peak power spectral density shall not exceed 11 dBm in any 1–MHz band. If transmitting antennas of directional gain greater than 6 dBi are used, both the maximum conducted output power and the peak power spectral density shall be reduced by the amount in dB that the directional gain of the antenna exceeds 6 dBi.

IC RSS-210 A9.2 (1)

The maximum e.i.r.p. shall not exceed 200 mW or $10 + 10 \log_{10} B$, dBm, whichever power is less. B is the 99% emission bandwidth in MHz. The e.i.r.p. spectral density shall not exceed 10 dBm in any 1.0 MHz band.

DIRECTIONAL ANTENNA GAIN

There is only one transmitter output therefore the directional gain is equal to the antenna gain.

RESULTS

Bandwidth and Antenna Gain

Channel	Frequency (MHz)	Min 26 dB BW (MHz)	Min 99% BW (MHz)	Directional Gain (dBi)
Low	5260	19.2	16.7	2.11
Mid	5300	19.1	16.4	2.11
High	5320	19.5	16.4	2.11

Limits

Channel	Frequency (MHz)	FCC Power Limit (dBm)	IC Power Limit (dBm)	IC EIRP Limit (dBm)	Power Limit (dBm)	FCC PPSD Limit (dBm)	IC PSD Limit (dBm)	PPSD Limit (dBm)
Low	5260	23.83	23.23	29.23	23.23	11.00	11.00	11.00
Mid	5300	23.81	23.15	29.15	23.15	11.00	11.00	11.00
High	5320	23.90	23.15	29.15	23.15	11.00	11.00	11.00

Duty Cycle CF (dB)	0.00	Included in Calculations of Corr'd Power & PPSD
---------------------------	------	--

Output Power Results

Channel	Frequency (MHz)	Chain 0 Meas Power (dBm)	Total Corr'd Power (dBm)	Power Limit (dBm)	Power Margin (dB)
Low	5260	16.477	16.477	23.23	-6.75
Mid	5300	16.534	16.534	23.15	-6.61
High	5320	15.288	15.288	23.15	-7.86

PPSD Results

Channel	Frequency (MHz)	Chain 0 Meas PPSD (dBm)	Total Corr'd PPSD (dBm)	PPSD Limit (dBm)	PPSD Margin (dB)
Low	5260	6.35	6.35	11.00	-4.65
Mid	5300	6.44	6.44	11.00	-4.56
High	5320	6.14	6.14	11.00	-4.86

OUTPUT POWER AND PPSD, Chain 0

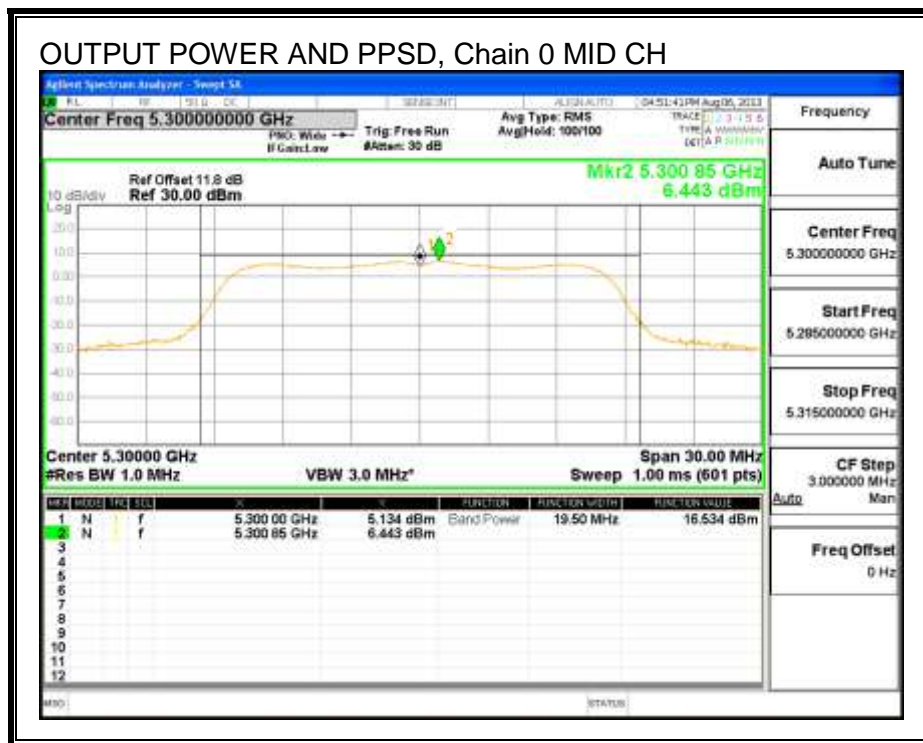
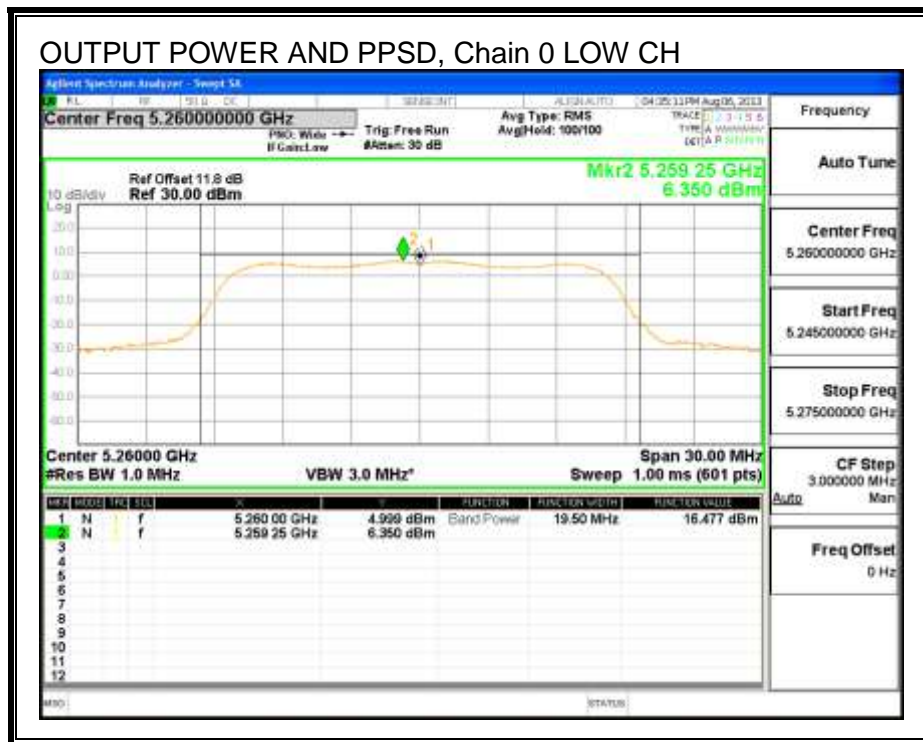

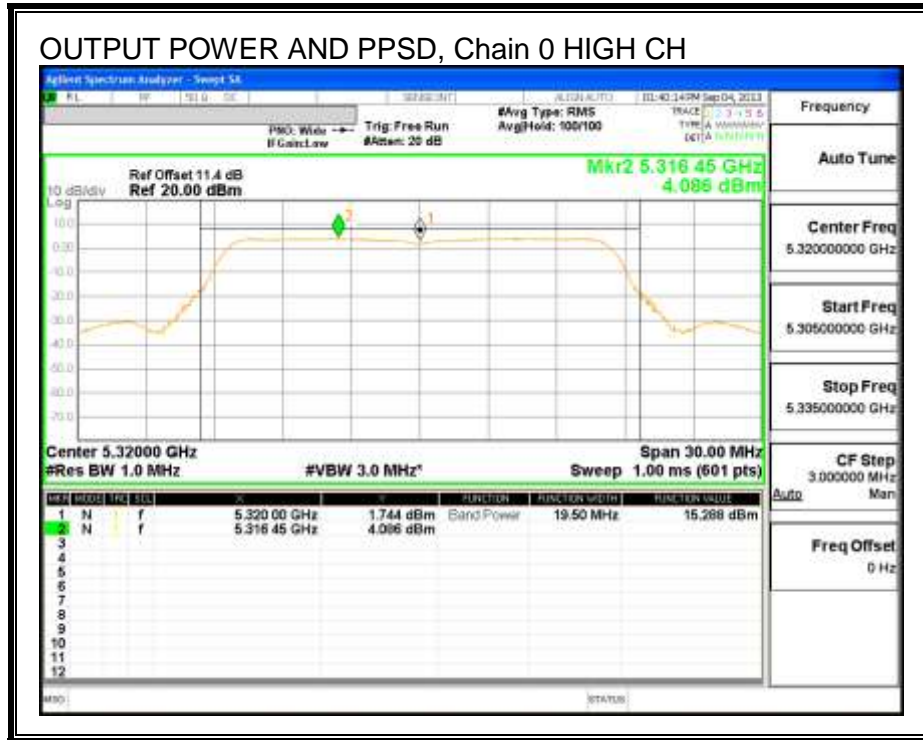

8.7.5. PEAK EXCURSION

LIMITS

FCC §15.407 (a) (6)

The ratio of the peak excursion of the modulation envelope (measured using a peak hold function) to the peak transmit power (measured as specified above) shall not exceed 13 dB across any 1 MHz bandwidth or the emission bandwidth whichever is less.

RESULTS

Channel	Frequency (MHz)	PK Level (dBm)	PSD (dBm)	DCCF (dB)	Peak Excursion (dB)	Limit (dB)	Margin (dB)
Mid	5300	15.13	6.44	0.00	8.69	13	-4.31

PEAK EXCURSION

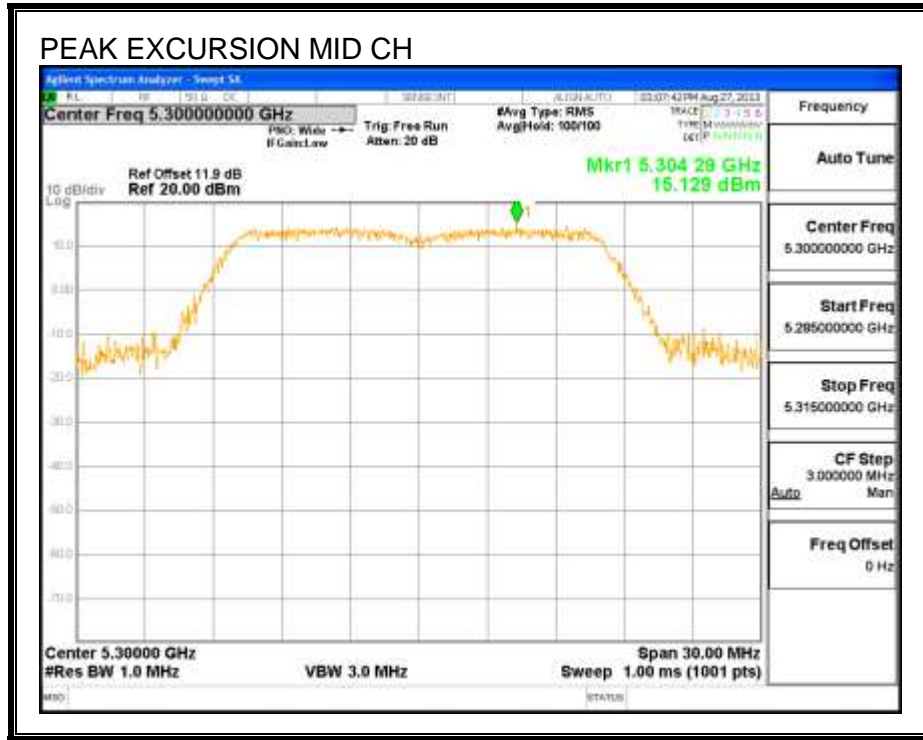

8.8. 802.11n HT20 CDD MODE IN THE 5.3 GHz BAND

8.8.1. 26 dB BANDWIDTH

LIMITS

None; for reporting purposes only.

RESULTS

Channel	Frequency (MHz)	26 dB BW Chain 0 (MHz)	26 dB BW Chain 1 (MHz)
Low	5260	21.08	20.40
Mid	5300	20.47	20.38
High	5320	20.36	20.73

26 dB BANDWIDTH, Chain 0

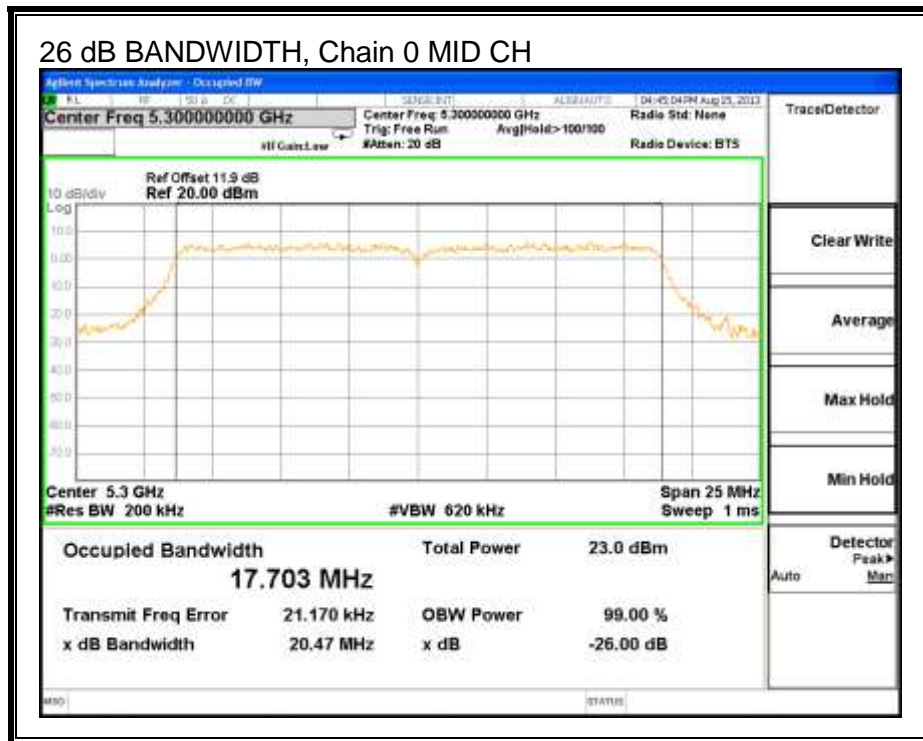
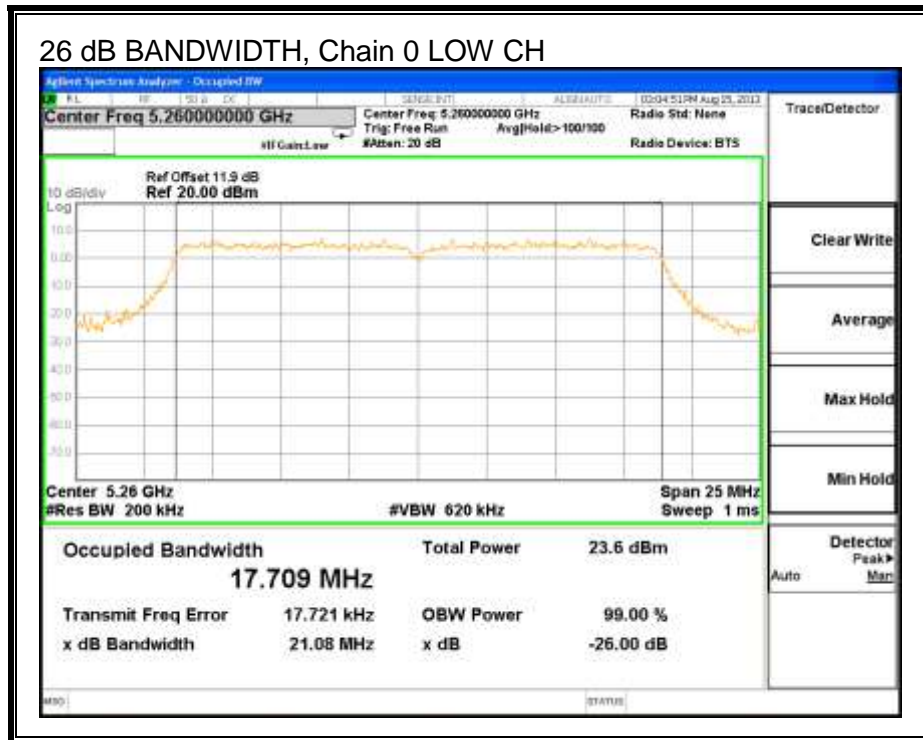

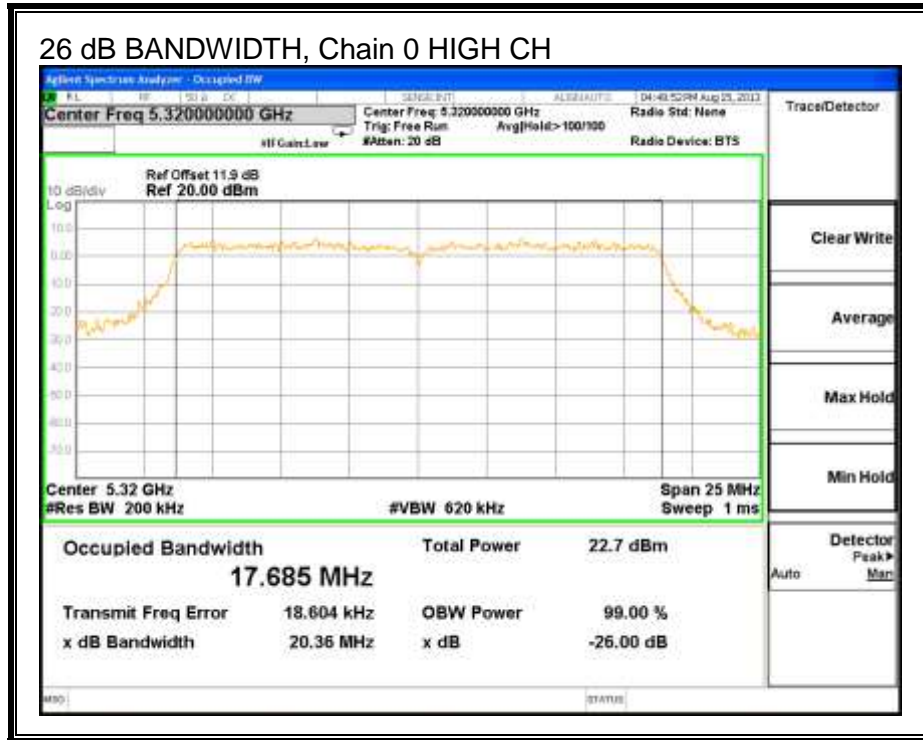

26 dB BANDWIDTH, Chain 1

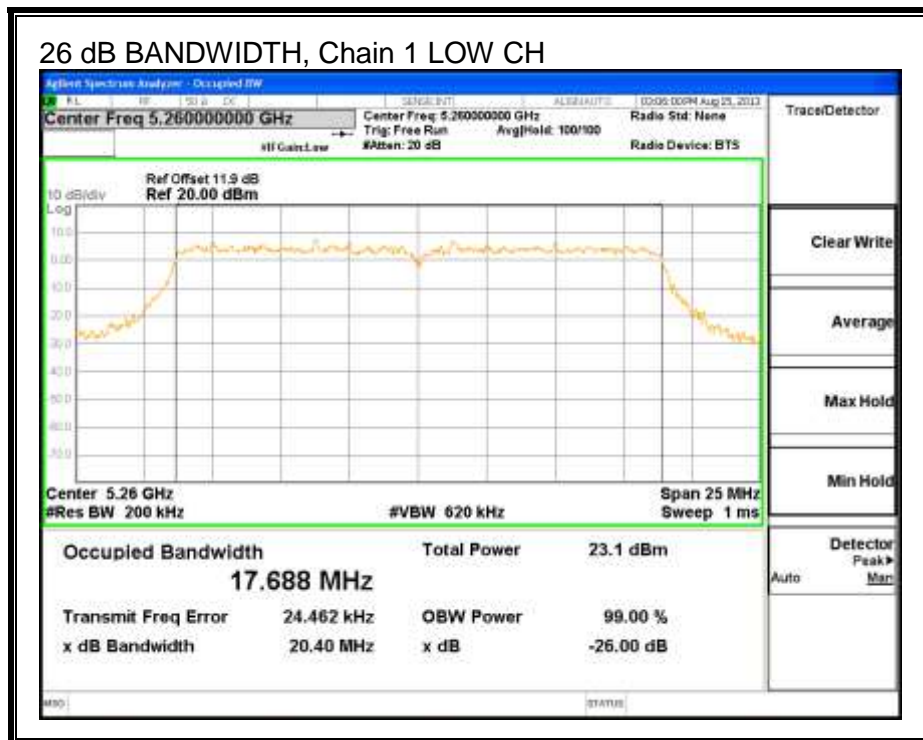

26 dB BANDWIDTH, Chain 1 MID CH

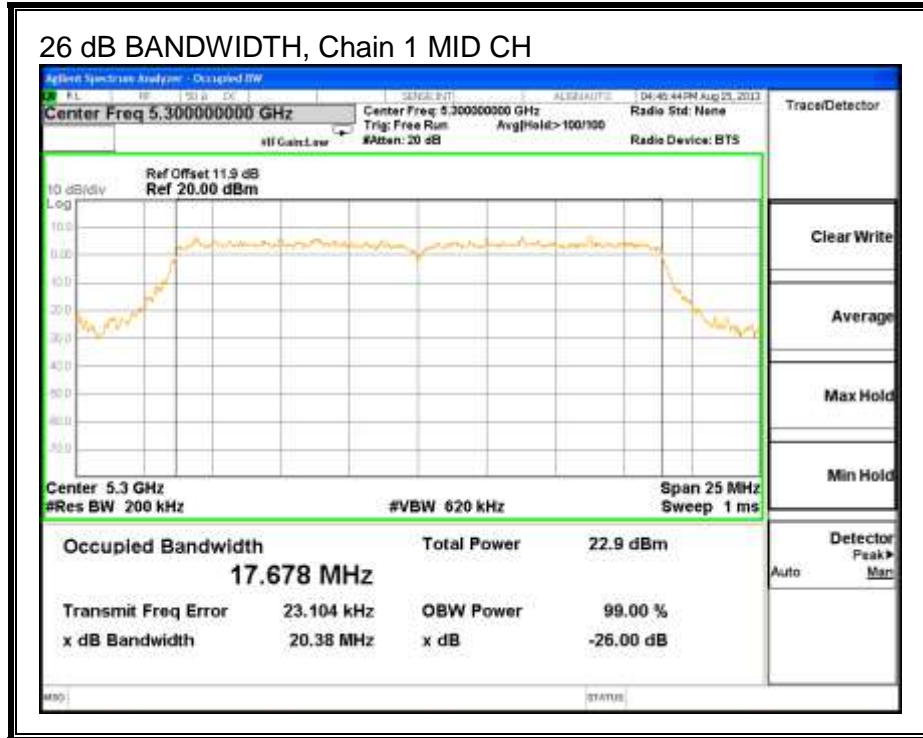

26 dB BANDWIDTH, Chain 1 HIGH CH

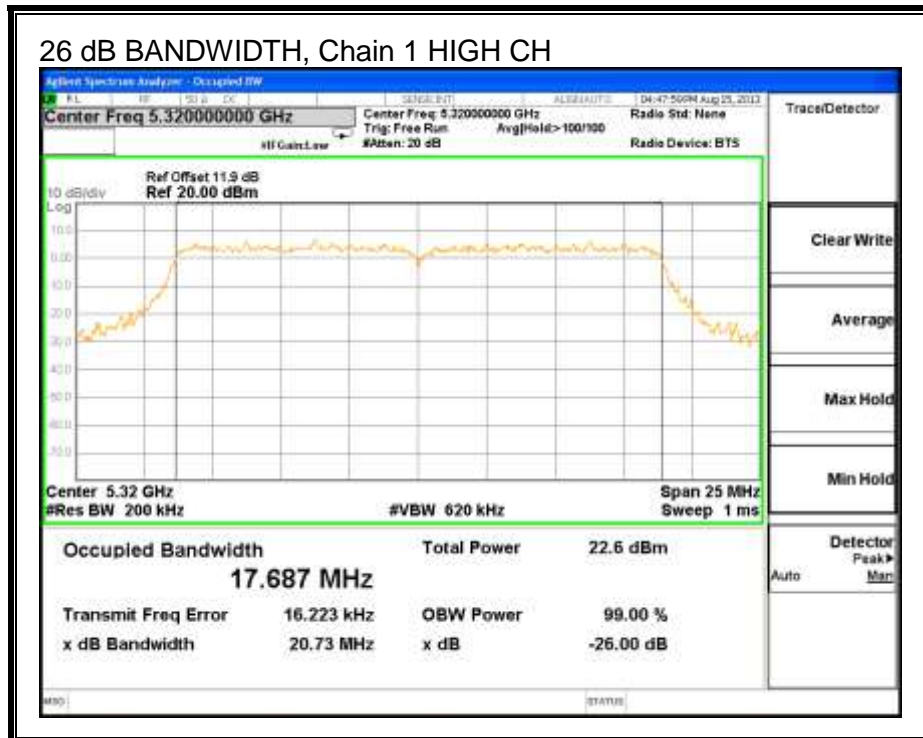

8.8.2. 99% BANDWIDTH

LIMITS

None; for reporting purposes only.

RESULTS

Channel	Frequency (MHz)	99% BW Chain 0 (MHz)	99% BW Chain 1 (MHz)
Low	5260	17.900	17.782
Mid	5300	17.890	17.823
High	5320	17.890	17.834

99% BANDWIDTH, Chain 0

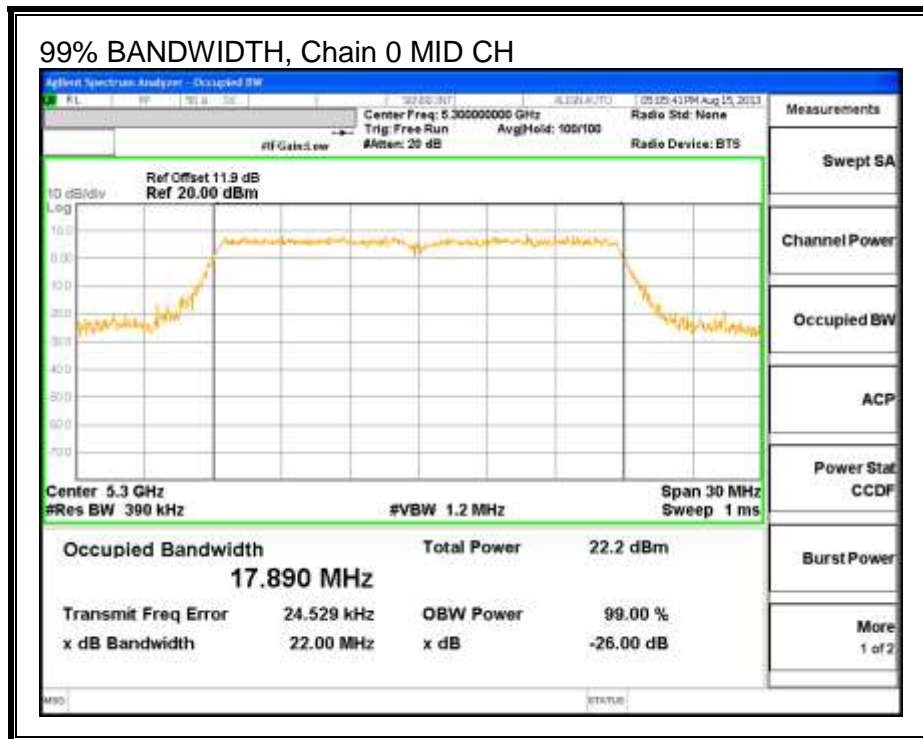
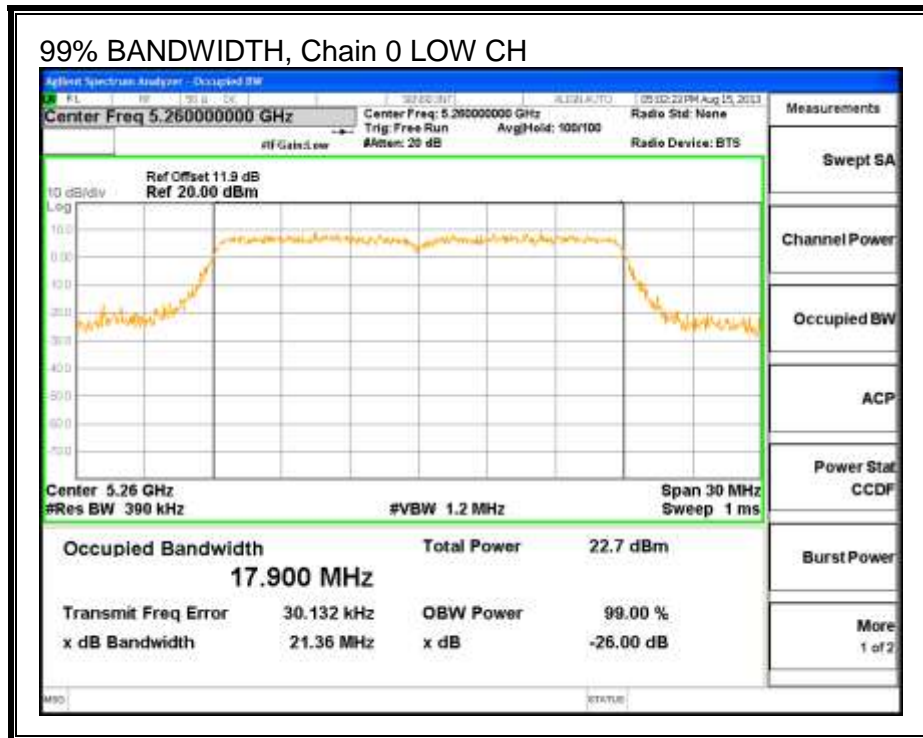

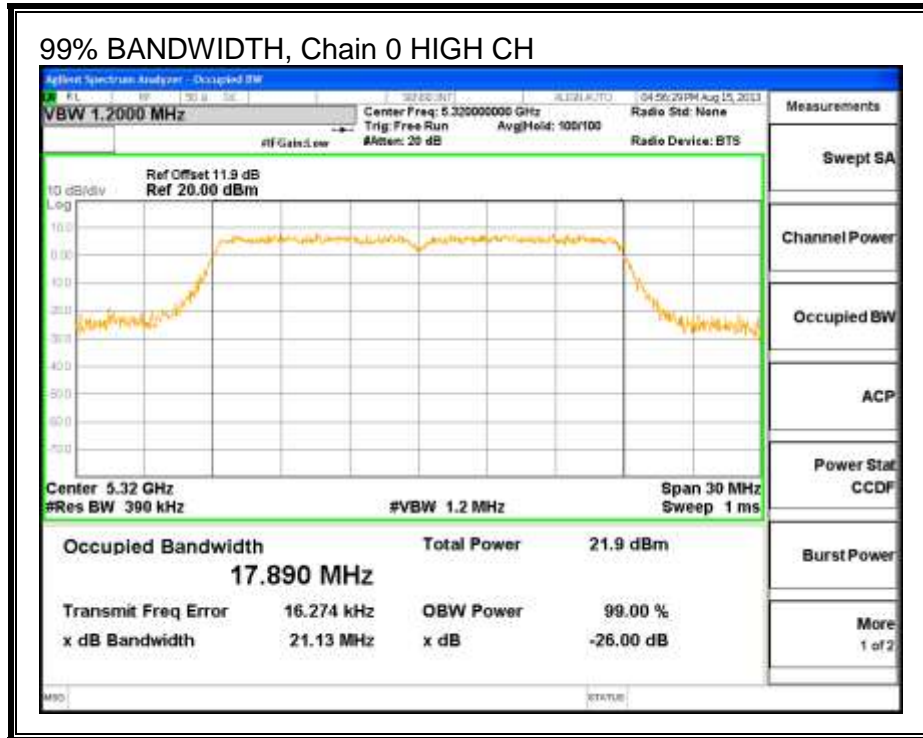

99% BANDWIDTH, Chain 1

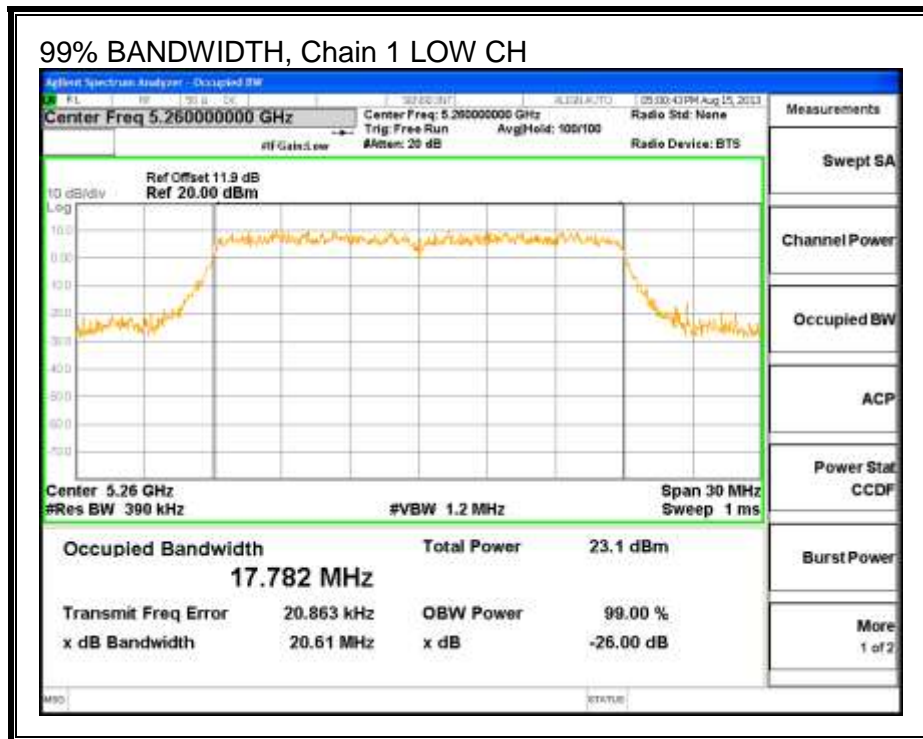

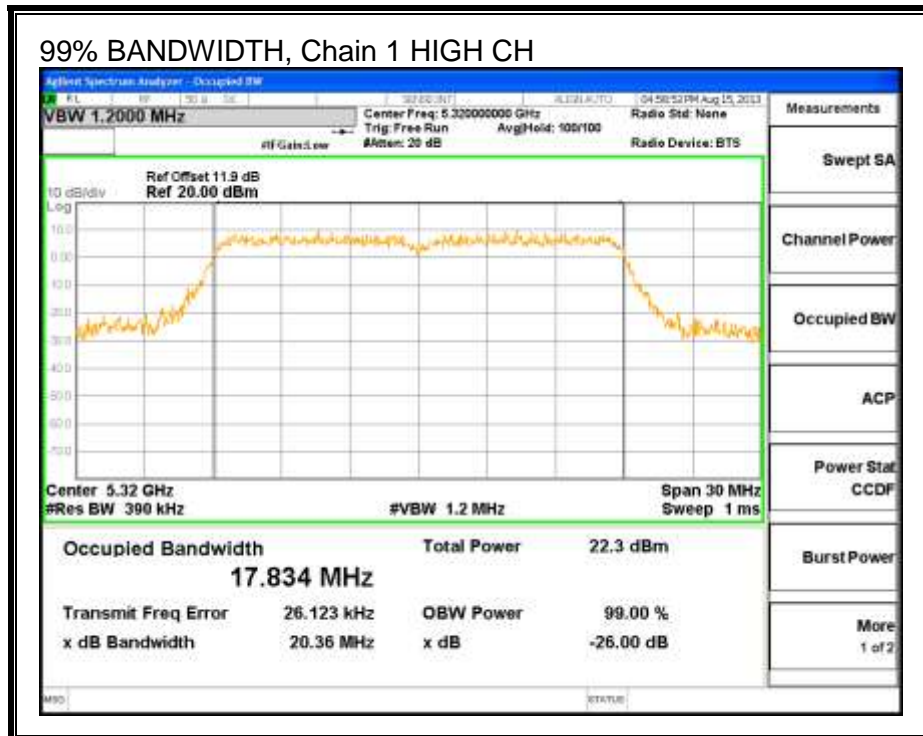
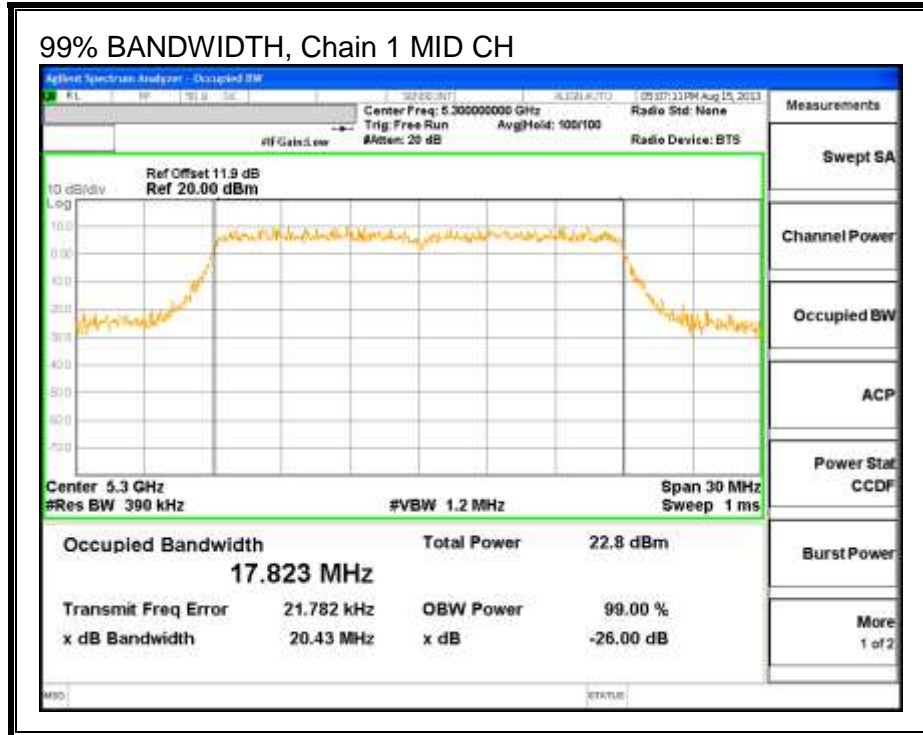

8.8.3. AVERAGE POWER

LIMITS

None; for reporting purposes only.

TEST PROCEDURE

The transmitter output is connected to a power meter.

The cable assembly insertion loss of 11.9 dB (including 10 dB pad and 1.9 dB cable) was entered as an offset in the power meter to allow for direct reading of power.

RESULTS

Average Power Results

Channel	Frequency (MHz)	Chain 0 Power (dBm)	Chain 1 Power (dBm)	Total Power (dBm)
Low	5260	16.50	16.48	19.50
Mid	5300	16.50	16.39	19.46
High	5320	14.00	13.91	16.97

8.8.4. OUTPUT POWER AND PPSD

LIMITS

FCC §15.407 (a) (1)

For the band 5.25–5.35 GHz, the maximum conducted output power over the frequency band of operation shall not exceed the lesser of 250 mW or 11 dBm + 10 log B, where B is the 26–dB emission bandwidth in MHz. In addition, the peak power spectral density shall not exceed 11 dBm in any 1–MHz band. If transmitting antennas of directional gain greater than 6 dBi are used, both the maximum conducted output power and the peak power spectral density shall be reduced by the amount in dB that the directional gain of the antenna exceeds 6 dBi.

IC RSS-210 A9.2 (1)

The maximum e.i.r.p. shall not exceed 200 mW or 10 + 10 log₁₀ B, dBm, whichever power is less. B is the 99% emission bandwidth in MHz. The e.i.r.p. spectral density shall not exceed 10 dBm in any 1.0 MHz band.

DIRECTIONAL ANTENNA GAIN

For output power, the TX chains are uncorrelated and the antenna gain is unequal among the chains. The directional gain is:

Chain 0 Antenna Gain (dBi)	Chain 1 Antenna Gain (dBi)	Uncorrelated Chains Directional Gain (dBi)
2.60	2.11	2.36

For PPSD, the TX chains are correlated and the antenna gain is unequal among the chains. The directional gain is:

Chain 0 Antenna Gain (dBi)	Chain 1 Antenna Gain (dBi)	Correlated Chains Directional Gain (dBi)
2.60	2.11	5.37

RESULTS

Bandwidth and Antenna Gain

Channel	Frequency (MHz)	Min 26 dB BW (MHz)	Min 99% BW (MHz)	Uncorrelated Directional Gain (dBi)	Correlated Directional Gain (dBi)
Low	5260	20.4	17.8	2.36	5.37
Mid	5300	20.4	17.8	2.36	5.37
High	5320	20.4	17.8	2.36	5.37

Limits

Channel	Frequency (MHz)	FCC Power Limit (dBm)	IC Power Limit (dBm)	IC EIRP Limit (dBm)	Power Limit (dBm)	FCC PPSD Limit (dBm)	IC PSD Limit (dBm)	PPSD Limit (dBm)
Low	5260	24.00	23.50	29.50	23.50	11.00	11.00	11.00
Mid	5300	24.00	23.51	29.51	23.51	11.00	11.00	11.00
High	5320	24.00	23.51	29.51	23.51	11.00	11.00	11.00

Duty Cycle CF (dB)	0.00	Included in Calculations of Corr'd Power & PPSD
---------------------------	------	--

Output Power Results

Channel	Frequency (MHz)	Chain 0 Meas Power (dBm)	Chain 1 Meas Power (dBm)	Total Corr'd Power (dBm)	Power Limit (dBm)	Power Margin (dB)
Low	5260	16.77	16.73	19.76	23.50	-3.74
Mid	5300	16.65	16.50	19.59	23.51	-3.92
High	5320	14.20	13.98	17.10	23.51	-6.41

PPSD Results

Channel	Frequency (MHz)	Chain 0 Meas PPSD (dBm)	Chain 1 Meas PPSD (dBm)	Total Corr'd PPSD (dBm)	PPSD Limit (dBm)	PPSD Margin (dB)
Low	5260	5.55	5.34	8.46	11.00	-2.54
Mid	5300	4.64	4.11	7.40	11.00	-3.60
High	5320	2.80	2.68	5.75	11.00	-5.25

OUTPUT POWER AND PPSD, Chain 0

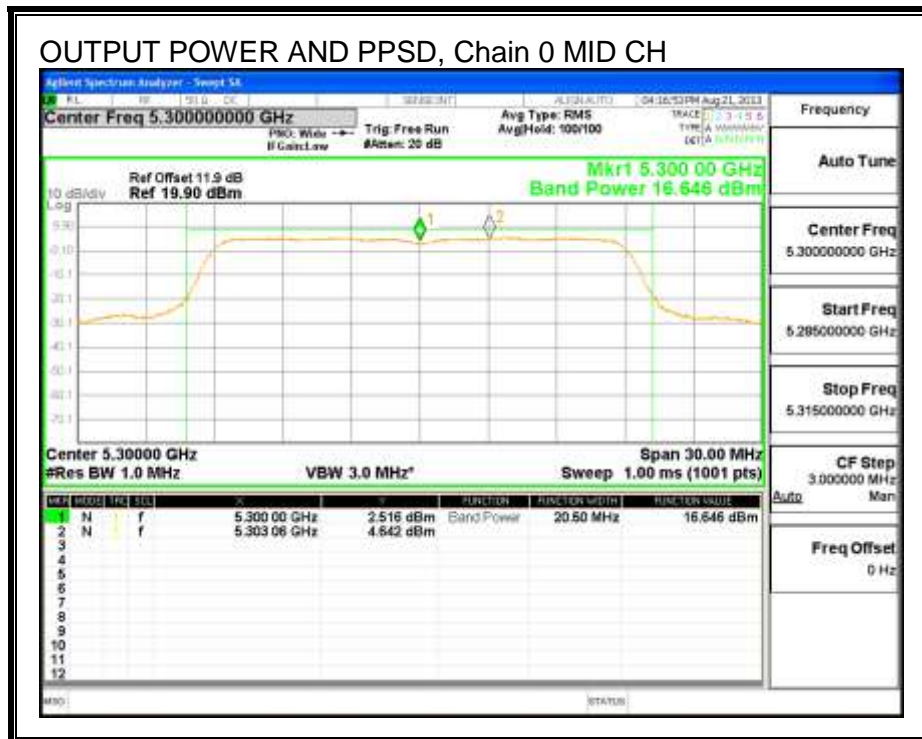
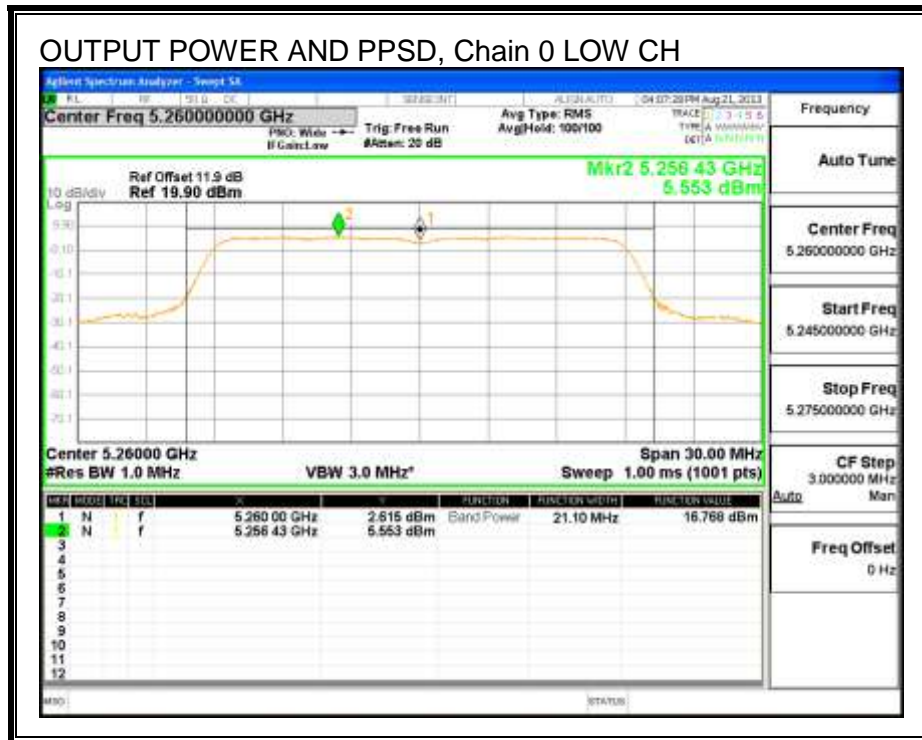

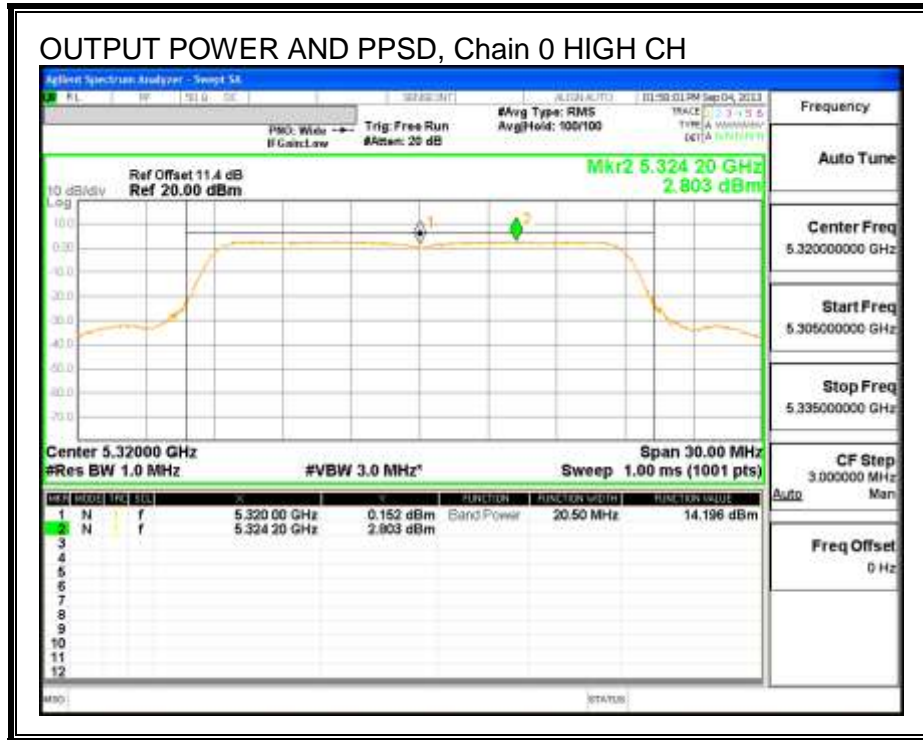

OUTPUT POWER AND PPSD, Chain 1

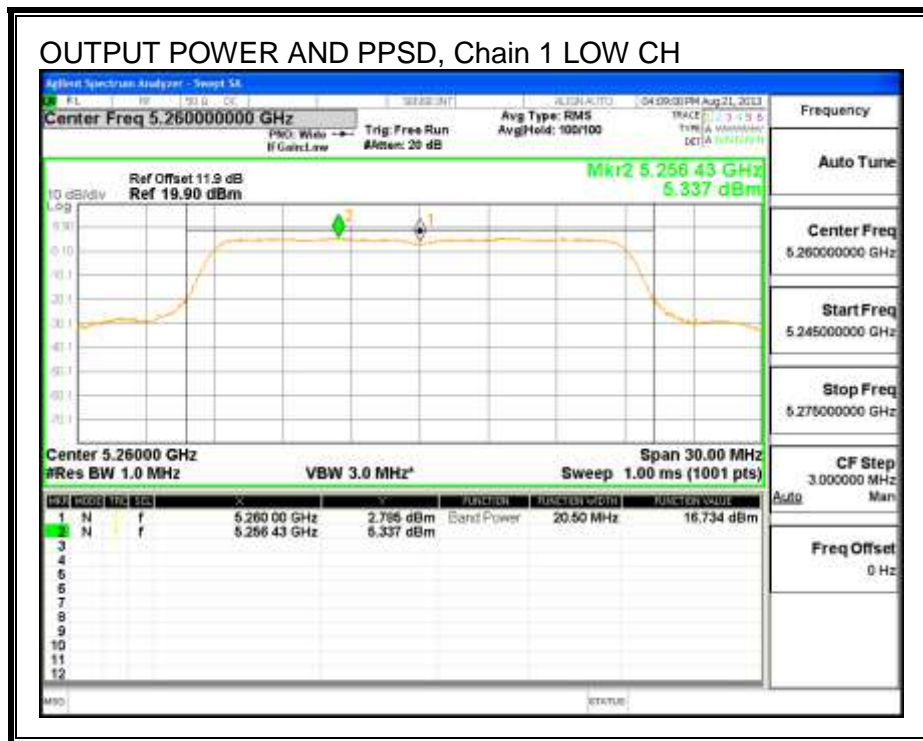

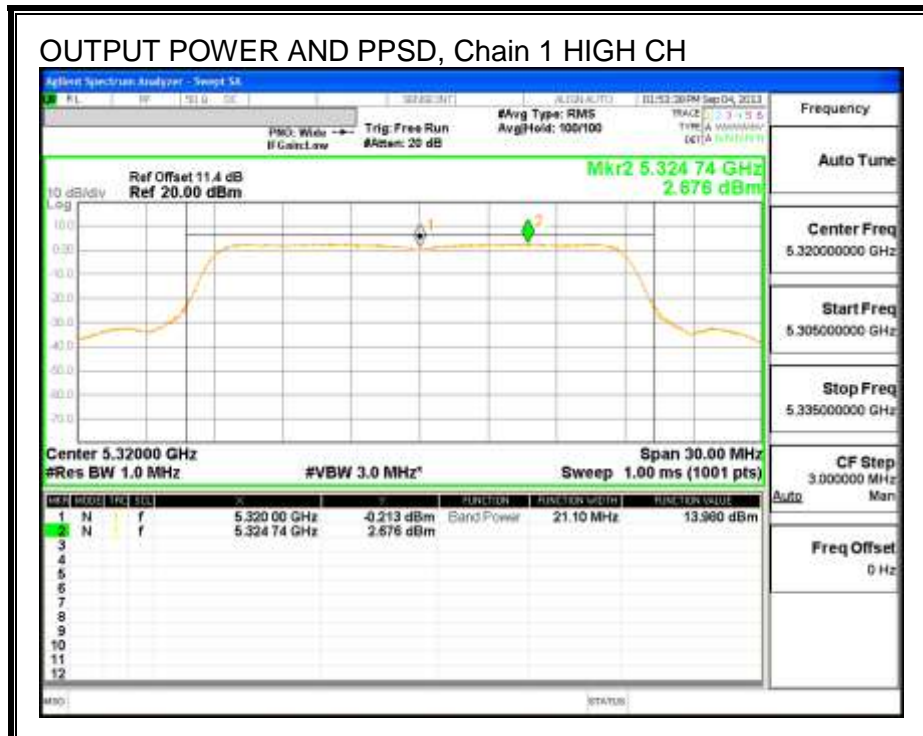
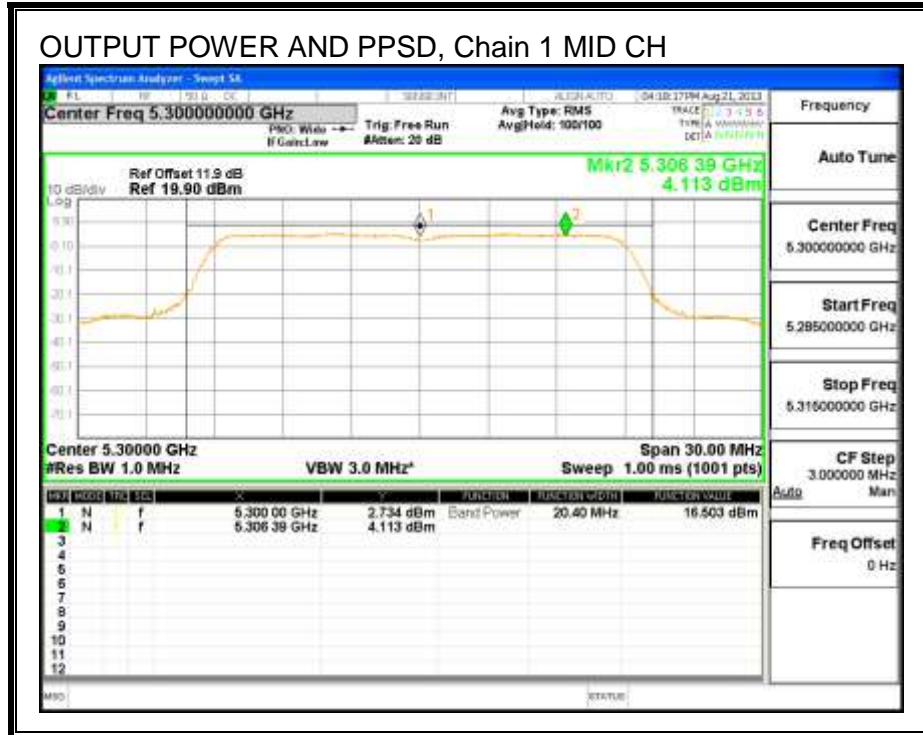

8.8.5. PEAK EXCURSION

LIMITS

FCC §15.407 (a) (6)

The ratio of the peak excursion of the modulation envelope (measured using a peak hold function) to the peak transmit power (measured as specified above) shall not exceed 13 dB across any 1 MHz bandwidth or the emission bandwidth whichever is less.

RESULTS

Chain 0

Channel	Frequency (MHz)	PK Level (dBm)	PSD (dBm)	DCCF (dB)	Peak Excursion (dB)	Limit (dB)	Margin (dB)
Mid	5300	12.25	4.64	0.00	7.61	13	-5.39

Chain 1

Channel	Frequency (MHz)	PK Level (dBm)	PSD (dBm)	DCCF (dB)	Peak Excursion (dB)	Limit (dB)	Margin (dB)
Mid	5300	13.15	4.11	0.00	9.04	13	-3.96

PEAK EXCURSION, Chain 0

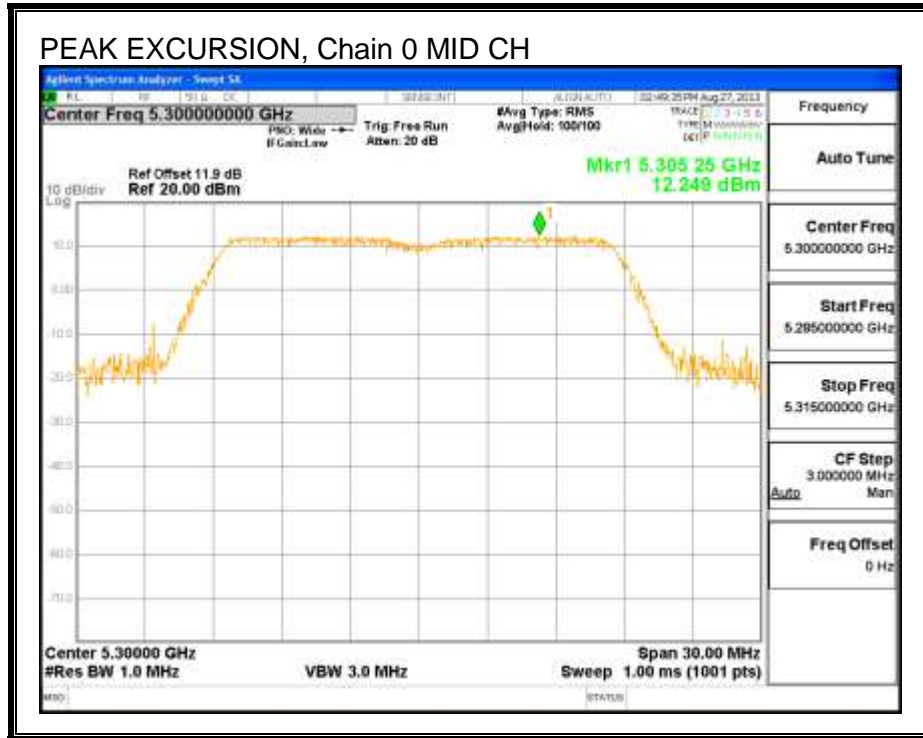

PEAK EXCURSION, Chain 1

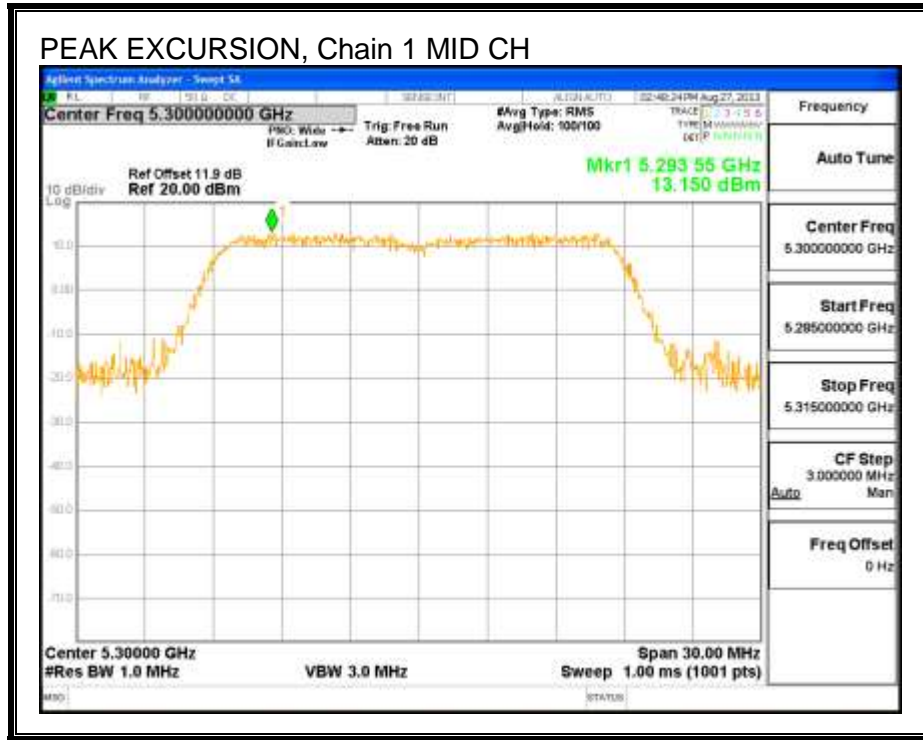

8.9. 802.11n HT40 SISO MODE IN THE 5.3 GHz BAND

8.9.1. 26 dB BANDWIDTH

LIMITS

None; for reporting purposes only.

RESULTS

Channel	Frequency (MHz)	26 dB Bandwidth (MHz)
Low	5270	40.08
High	5310	40.02

26 dB BANDWIDTH

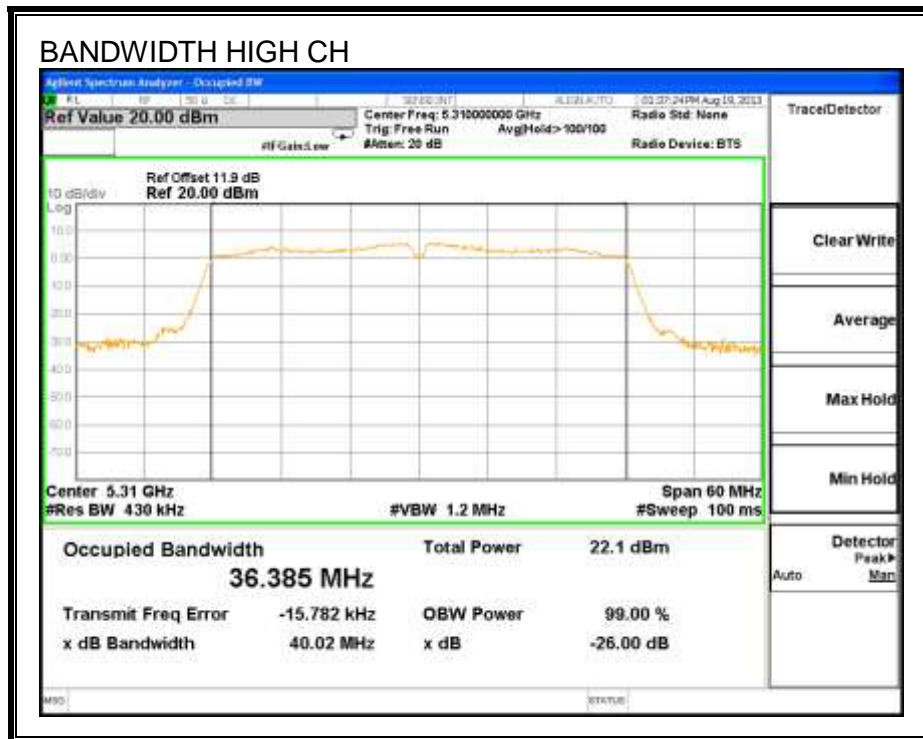
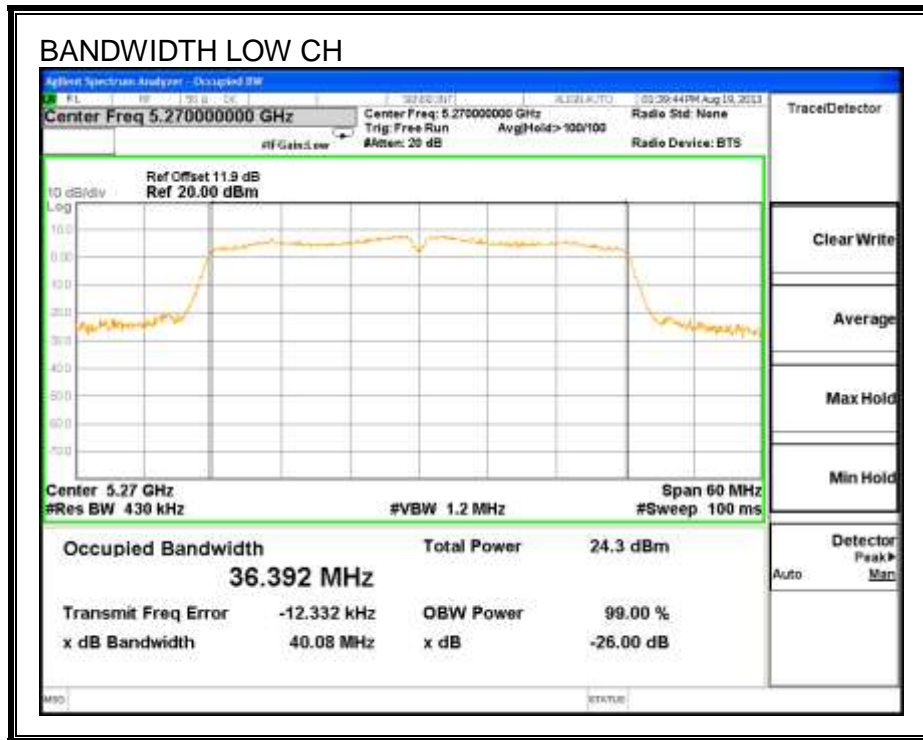

8.9.2. 99% BANDWIDTH

LIMITS

None; for reporting purposes only.

RESULTS

Channel	Frequency (MHz)	99% Bandwidth (MHz)
Low	5270	36.52
High	5310	36.52

99% BANDWIDTH

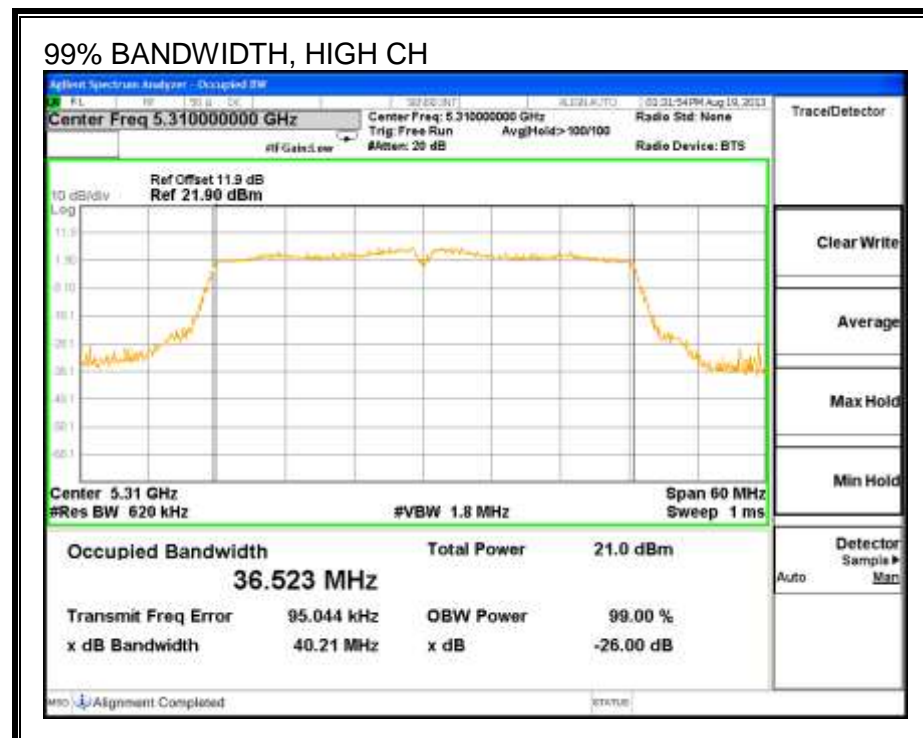
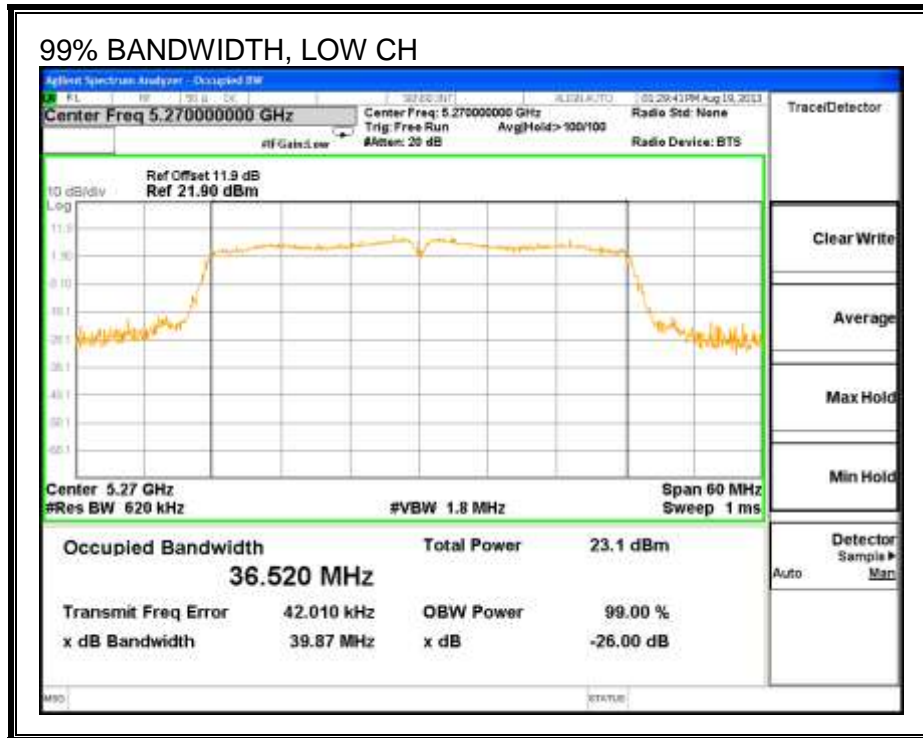

8.9.3. AVERAGE POWER

LIMITS

None; for reporting purposes only.

TEST PROCEDURE

The transmitter output is connected to a power meter.

The cable assembly insertion loss of 11.9 dB (including 10 dB pad and 1.9 dB cable) was entered as an offset in the power meter to allow for direct reading of power.

RESULTS

Channel	Frequency (MHz)	Power (dBm)
Low	5270	16.40
High	5310	14.50

8.9.4. OUTPUT POWER AND PPSD

LIMITS

FCC §15.407 (a) (1)

For the band 5.25–5.35 GHz, the maximum conducted output power over the frequency band of operation shall not exceed the lesser of 250 mW or $11 \text{ dBm} + 10 \log B$, where B is the 26–dB emission bandwidth in MHz. In addition, the peak power spectral density shall not exceed 11 dBm in any 1–MHz band. If transmitting antennas of directional gain greater than 6 dBi are used, both the maximum conducted output power and the peak power spectral density shall be reduced by the amount in dB that the directional gain of the antenna exceeds 6 dBi.

IC RSS-210 A9.2 (1)

The maximum e.i.r.p. shall not exceed 200 mW or $10 + 10 \log_{10} B$, dBm, whichever power is less. B is the 99% emission bandwidth in MHz. The e.i.r.p. spectral density shall not exceed 10 dBm in any 1.0 MHz band.

DIRECTIONAL ANTENNA GAIN

There is only one transmitter output therefore the directional gain is equal to the antenna gain.

RESULTS

Bandwidth and Antenna Gain

Channel	Frequency (MHz)	Min 26 dB BW (MHz)	Min 99% BW (MHz)	Directional Gain (dBi)
Low	5270	40.1	36.5	2.11
High	5310	40.0	36.5	2.11

Limits

Channel	Frequency (MHz)	FCC Power Limit (dBm)	IC Power Limit (dBm)	IC EIRP Limit (dBm)	Power Limit (dBm)	FCC PPSD Limit (dBm)	IC PSD Limit (dBm)	PPSD Limit (dBm)
Low	5270	24.00	24.00	30.00	24.00	11.00	11.00	11.00
High	5310	24.00	24.00	30.00	24.00	11.00	11.00	11.00

Duty Cycle CF (dB)	0.00	Included in Calculations of Corr'd Power & PSD
---------------------------	------	---

Output Power Results

Channel	Frequency (MHz)	Chain 0 Meas Power (dBm)	Total Corr'd Power (dBm)	Power Limit (dBm)	Power Margin (dB)
Low	5270	16.60	16.60	24.00	-7.40
High	5310	14.66	14.66	24.00	-9.34

PPSD Results

Channel	Frequency (MHz)	Chain 0 Meas PPSD (dBm)	Total Corr'd PPSD (dBm)	PPSD Limit (dBm)	PPSD Margin (dB)
Low	5270	3.94	3.94	11.00	-7.06
High	5310	1.70	1.70	11.00	-9.30

OUTPUT POWER AND PPSD, Chain 0

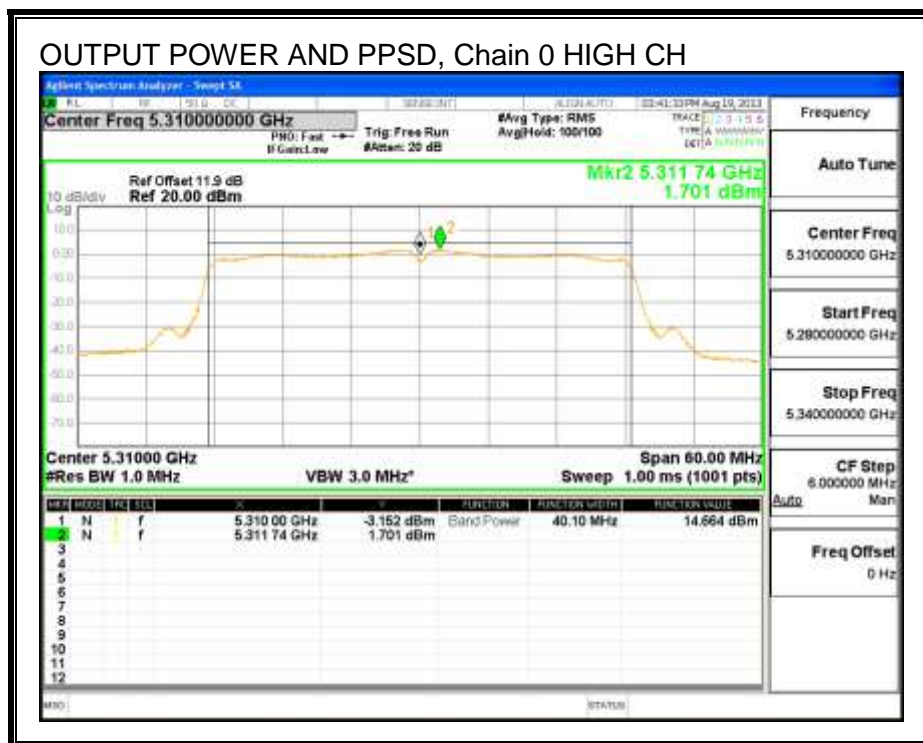
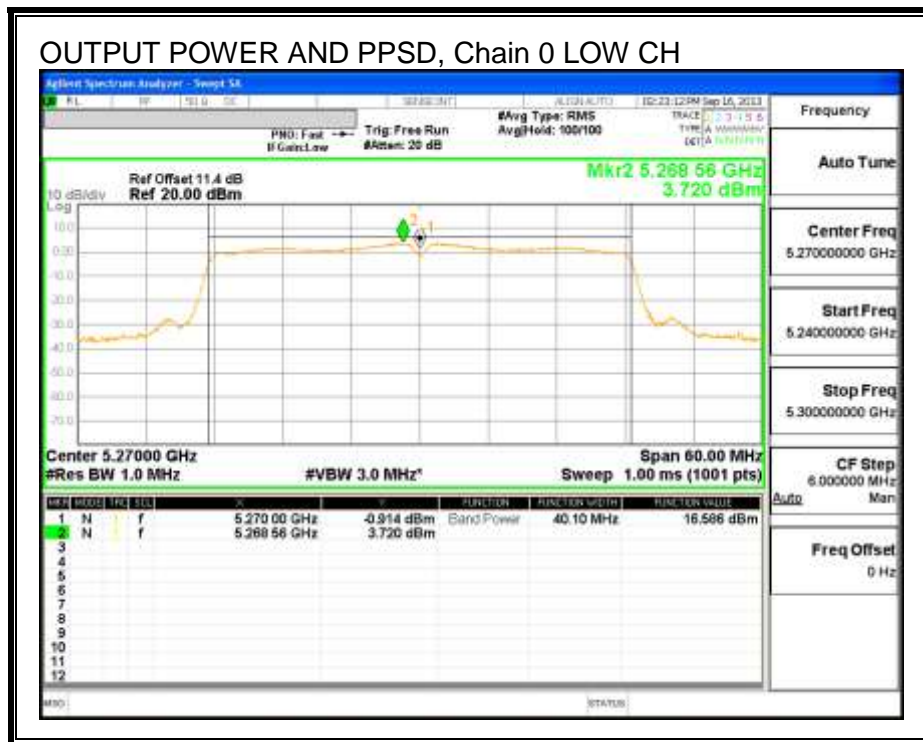

8.9.5. PEAK EXCURSION

LIMITS

FCC §15.407 (a) (6)

The ratio of the peak excursion of the modulation envelope (measured using a peak hold function) to the peak transmit power (measured as specified above) shall not exceed 13 dB across any 1 MHz bandwidth or the emission bandwidth whichever is less.

RESULTS

Channel	Frequency (MHz)	PK Level (dBm)	PSD (dBm)	DCCF (dB)	Peak Excursion (dB)	Limit (dB)	Margin (dB)
Mid	5270	11.461	3.94	0.00	7.52	13	-5.48

PEAK EXCURSION

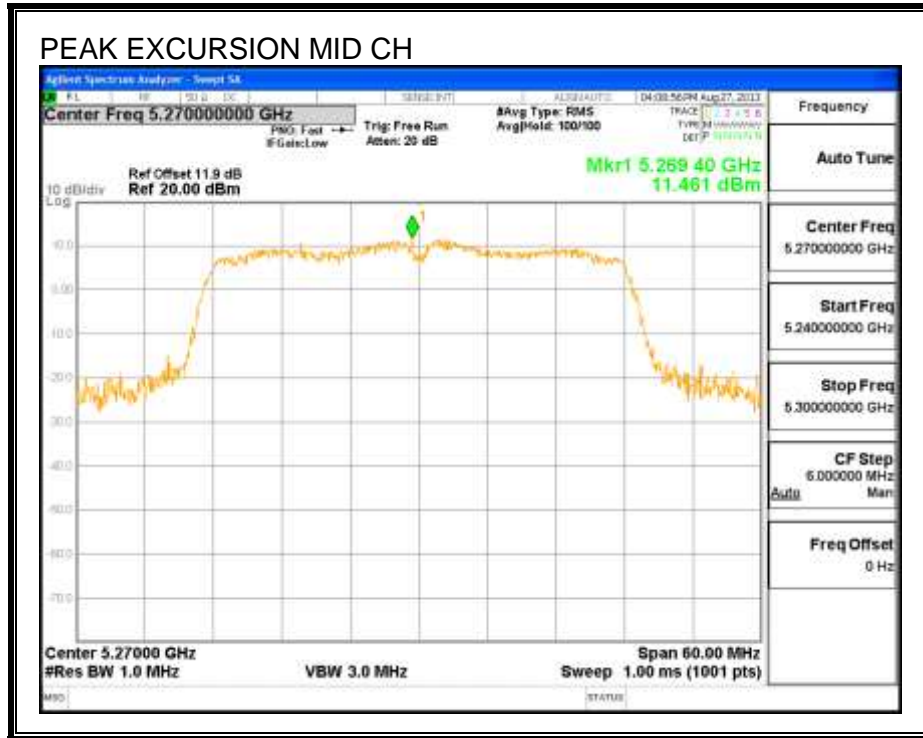

8.10. 802.11n HT40 2TX CDD MODE IN THE 5.3 GHZ BAND

8.10.1. 26 dB BANDWIDTH

LIMITS

None; for reporting purposes only.

RESULTS

Channel	Frequency (MHz)	26 dB BW Chain 0 (MHz)	26 dB BW Chain 1 (MHz)
Low	5270	42.30	39.63
High	5310	40.13	39.51

26 dB BANDWIDTH, Chain 0

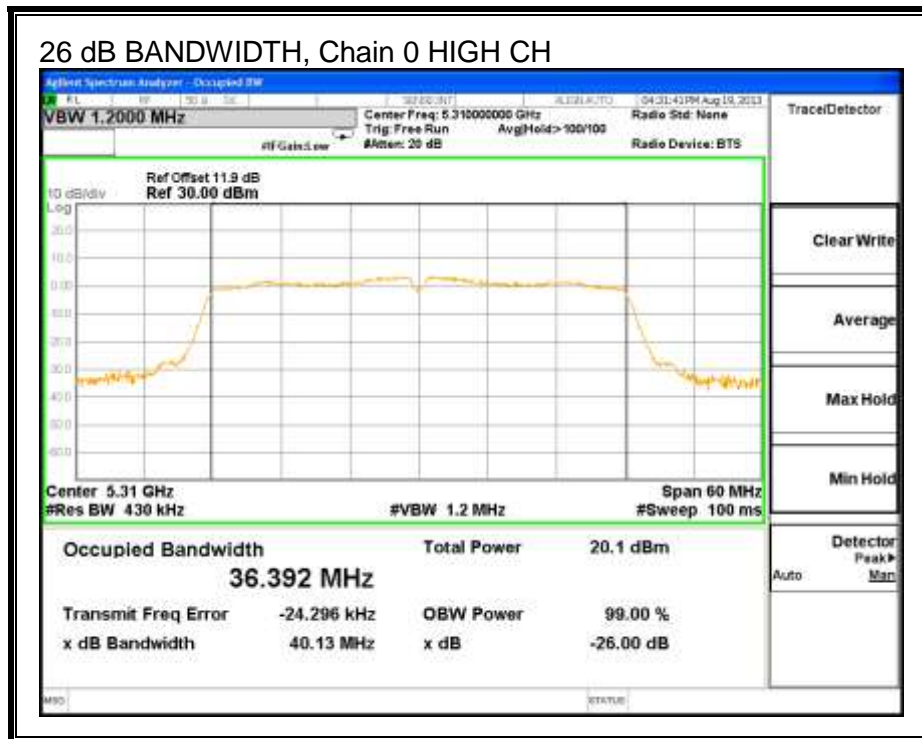
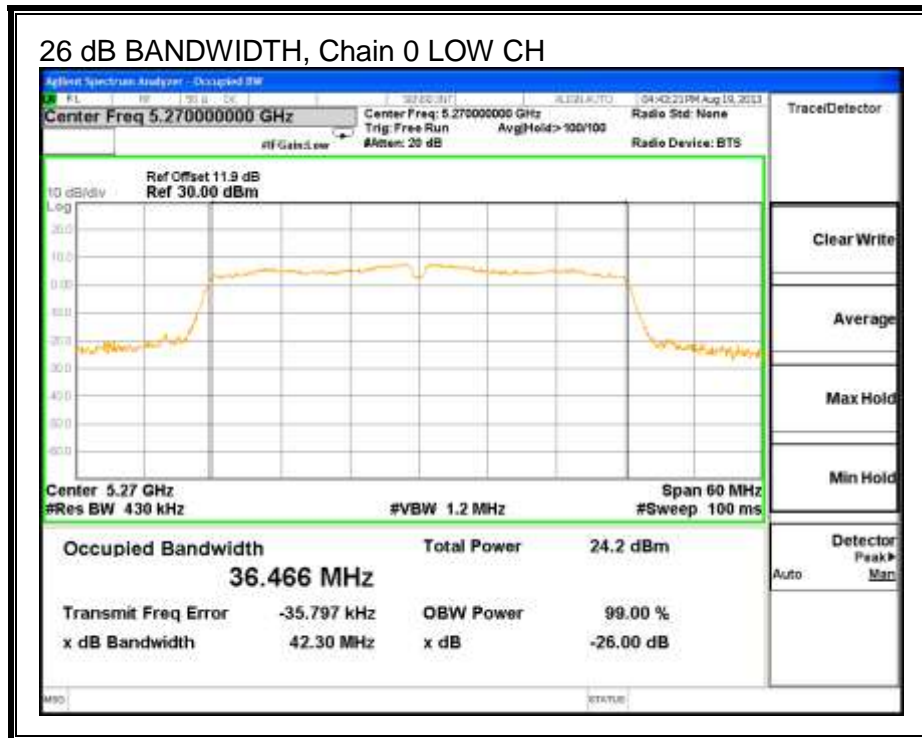

26 dB BANDWIDTH, Chain 1

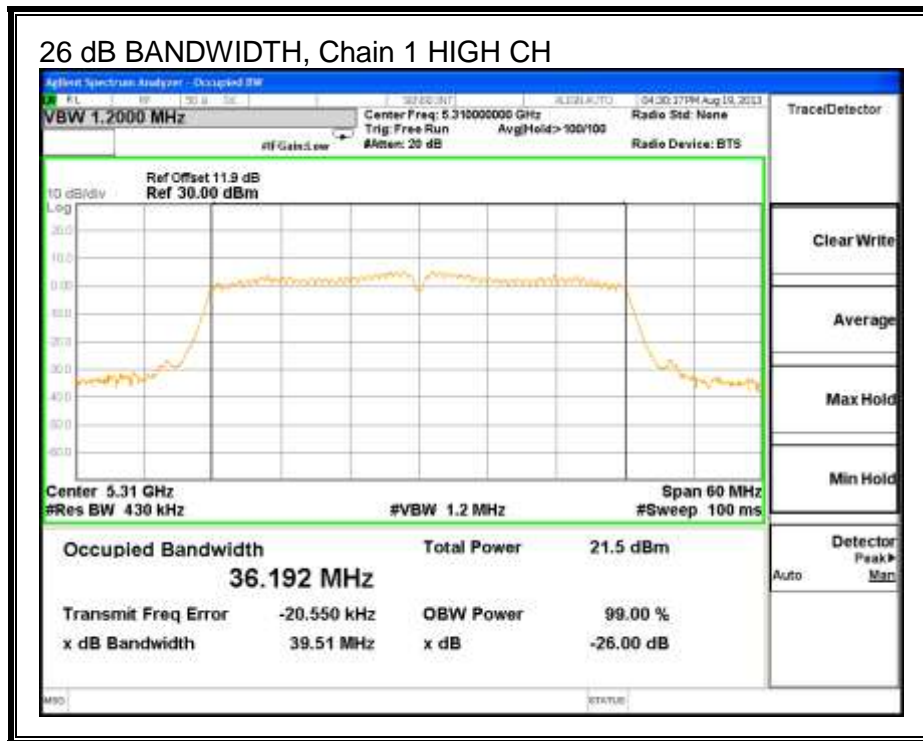
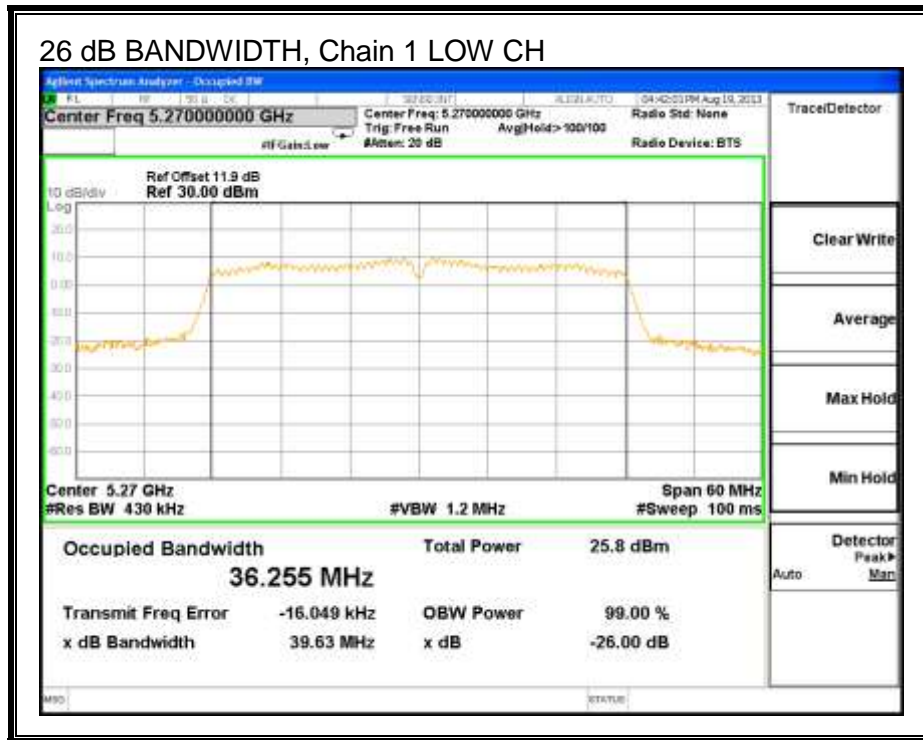

8.10.2. 99% BANDWIDTH

LIMITS

None; for reporting purposes only.

RESULTS

Channel	Frequency (MHz)	99% BW Chain 0 (MHz)	99% BW Chain 1 (MHz)
Low	5270	36.40	36.24
High	5310	36.31	36.21

99% BANDWIDTH, Chain 0

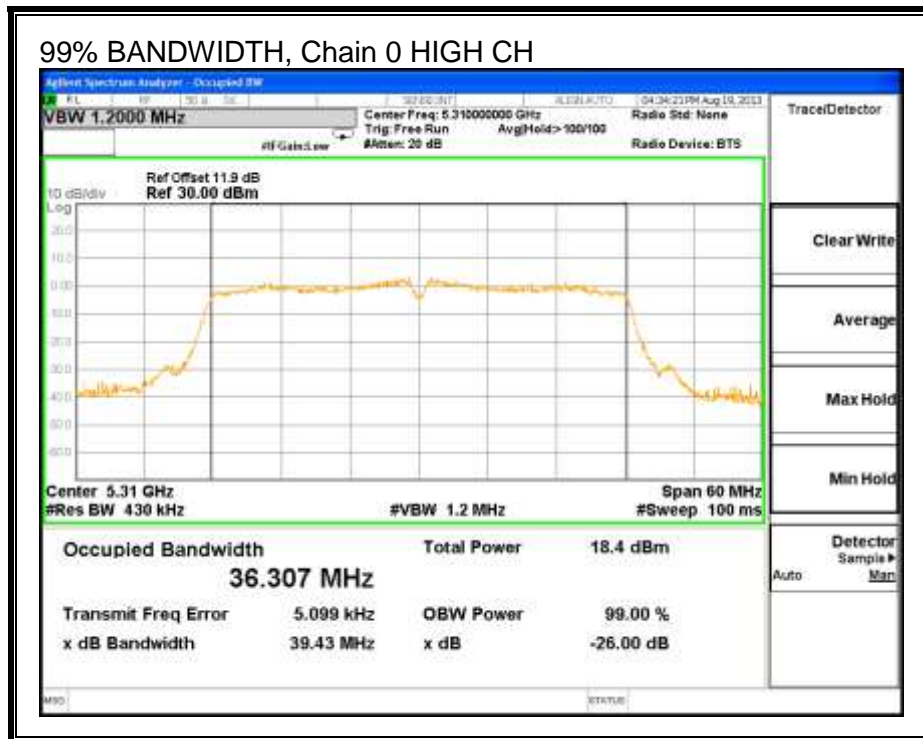
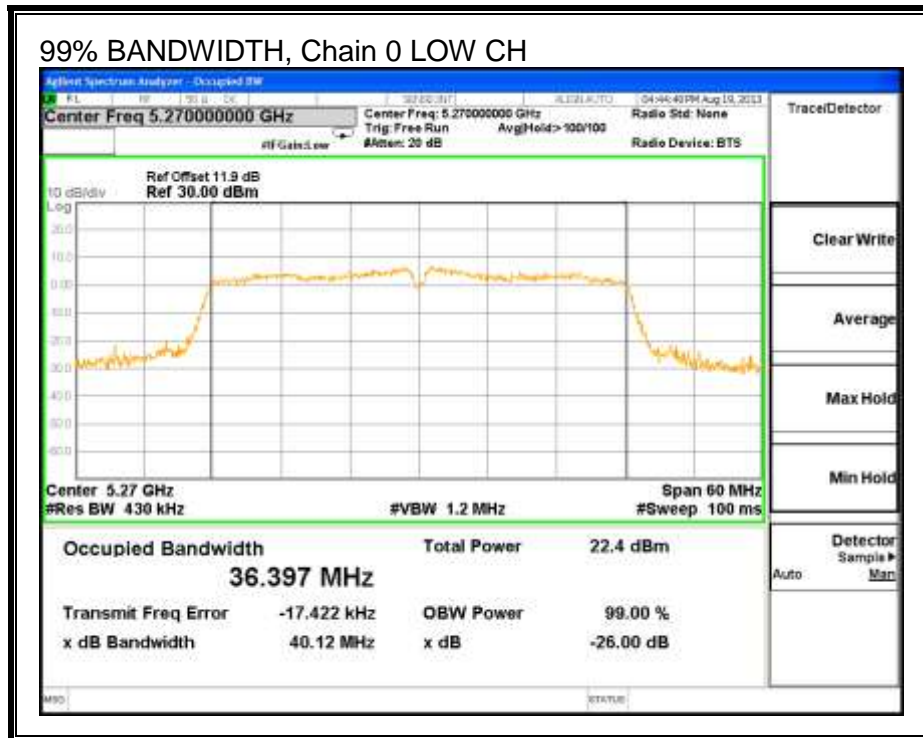

99% BANDWIDTH, Chain 1

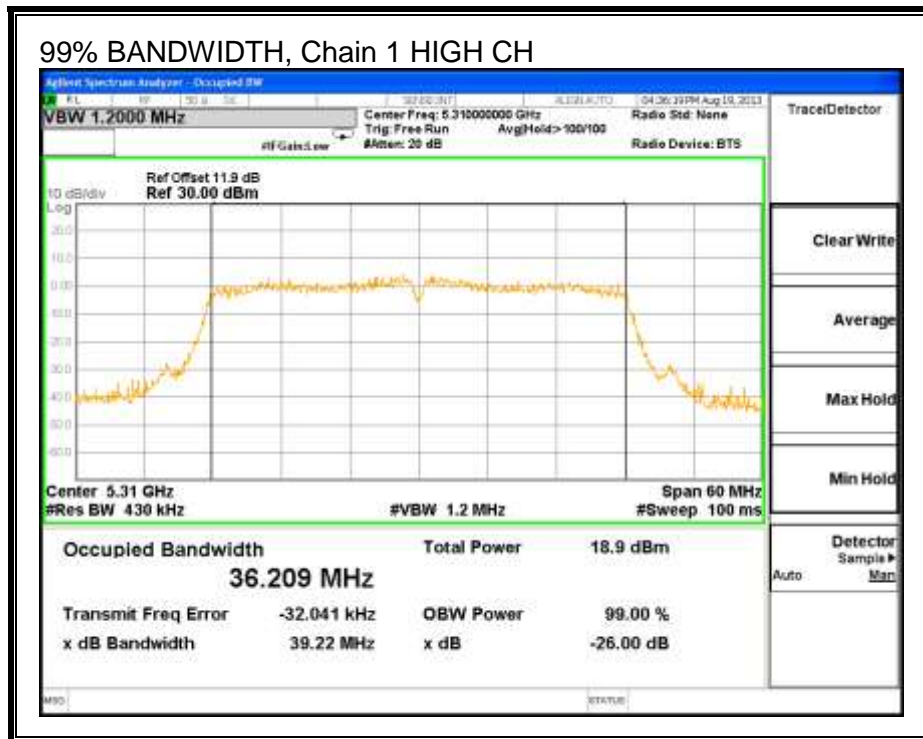
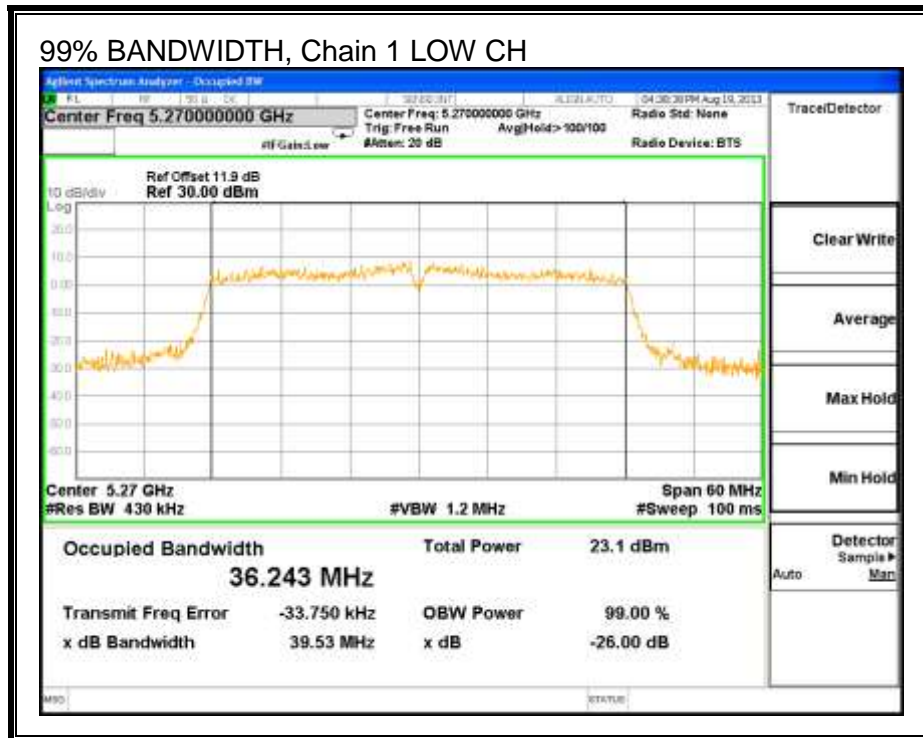

8.10.3. AVERAGE POWER

LIMITS

None; for reporting purposes only.

TEST PROCEDURE

The transmitter output is connected to a power meter.

The cable assembly insertion loss of 11.9 dB (including 10 dB pad and 1.9 dB cable) was entered as an offset in the power meter to allow for direct reading of power.

RESULTS

Average Power Results

Channel	Frequency (MHz)	Chain 0 Power (dBm)	Chain 1 Power (dBm)	Total Power (dBm)
Low	5270	16.48	16.50	19.50
High	5310	12.45	12.50	15.49

8.10.4. OUTPUT POWER AND PPSD

LIMITS

FCC §15.407 (a) (1)

For the band 5.25–5.35 GHz, the maximum conducted output power over the frequency band of operation shall not exceed the lesser of 250 mW or 11 dBm + 10 log B, where B is the 26–dB emission bandwidth in MHz. In addition, the peak power spectral density shall not exceed 11 dBm in any 1–MHz band. If transmitting antennas of directional gain greater than 6 dBi are used, both the maximum conducted output power and the peak power spectral density shall be reduced by the amount in dB that the directional gain of the antenna exceeds 6 dBi.

IC RSS-210 A9.2 (1)

The maximum e.i.r.p. shall not exceed 200 mW or 10 + 10 log₁₀ B, dBm, whichever power is less. B is the 99% emission bandwidth in MHz. The e.i.r.p. spectral density shall not exceed 10 dBm in any 1.0 MHz band.

DIRECTIONAL ANTENNA GAIN

For output power, the TX chains are uncorrelated and the antenna gain is unequal among the chains. The directional gain is:

Chain 0 Antenna Gain (dBi)	Chain 1 Antenna Gain (dBi)	Uncorrelated Chains Directional Gain (dBi)
2.60	2.11	2.36

For PPSD, the TX chains are correlated and the antenna gain is unequal among the chains. The directional gain is:

Chain 0 Antenna Gain (dBi)	Chain 1 Antenna Gain (dBi)	Correlated Chains Directional Gain (dBi)
2.60	2.11	5.37

RESULTS

Bandwidth and Antenna Gain

Channel	Frequency (MHz)	Min 26 dB BW (MHz)	Min 99% BW (MHz)	Uncorrelat Directional Gain (dBi)	Correlat Directio nal Gain (dBi)
Low	5270	39.6	36.2	2.36	5.37
High	5310	39.5	36.2	2.36	5.37

Limits

Channel	Frequency (MHz)	FCC Power Limit (dBm)	IC Power Limit (dBm)	IC EIRP Limit (dBm)	Power Limit (dBm)	FCC PPSD Limit (dBm)	IC PSD Limit (dBm)	PPSD Limit (dBm)
Low	5270	24.00	24.00	30.00	24.00	11.00	11.00	11.00
High	5310	24.00	24.00	30.00	24.00	11.00	11.00	11.00

Duty Cycle CF (dB)	0.00	Included in Calculations of Corr'd Power & PPSD
---------------------------	------	--

Output Power Results

Channel	Frequency (MHz)	Chain 0 Meas Power (dBm)	Chain 1 Meas Power (dBm)	Total Corr'd Power (dBm)	Power Limit (dBm)	Power Margin (dB)
Low	5270	16.69	16.68	19.69	24.00	-4.31
High	5310	12.61	12.69	15.66	24.00	-8.34

PPSD Results

Channel	Frequency (MHz)	Chain 0 Meas PPSD (dBm)	Chain 1 Meas PPSD (dBm)	Total Corr'd PPSD (dBm)	PPSD Limit (dBm)	PPSD Margin (dB)
Low	5270	4.15	3.86	7.02	11.00	-3.98
High	5310	-0.25	0.10	2.94	11.00	-8.06

OUTPUT POWER AND PPSD, Chain 0

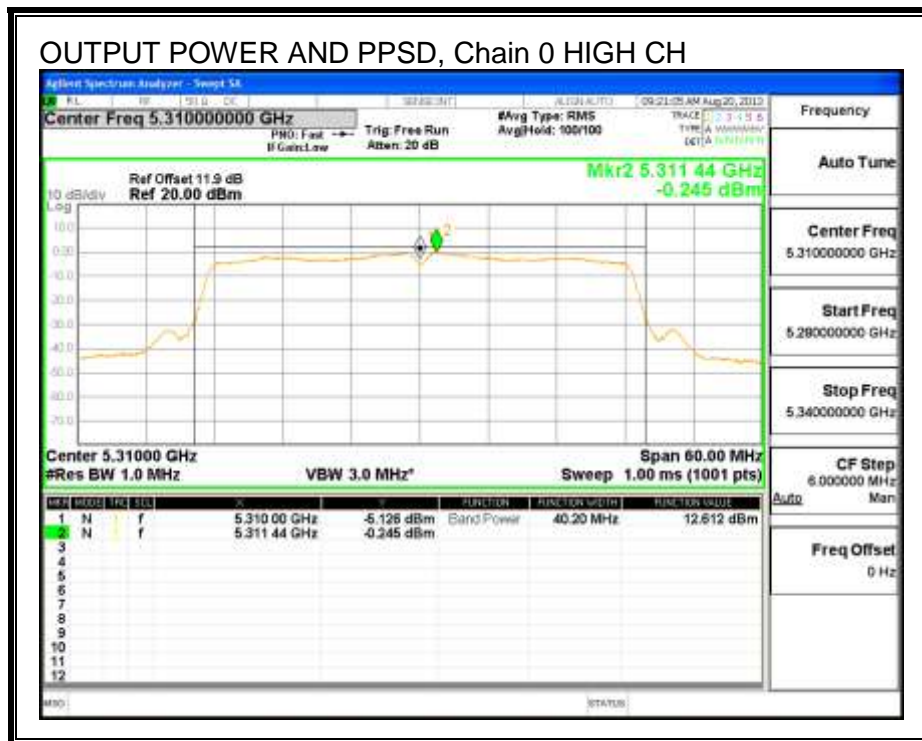
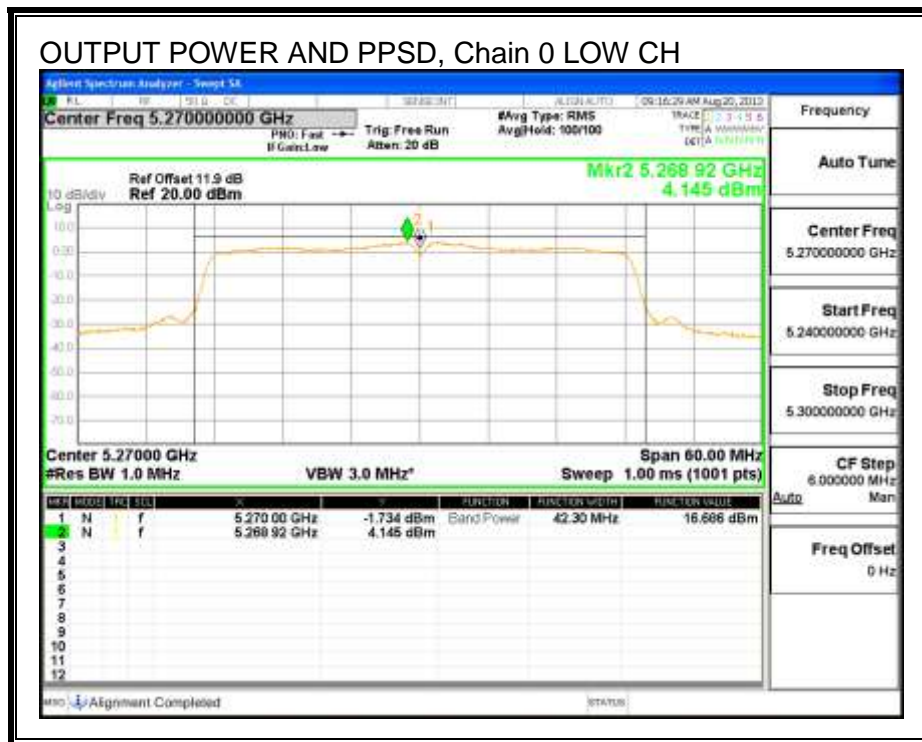

OUTPUT POWER AND PPSD, Chain 1

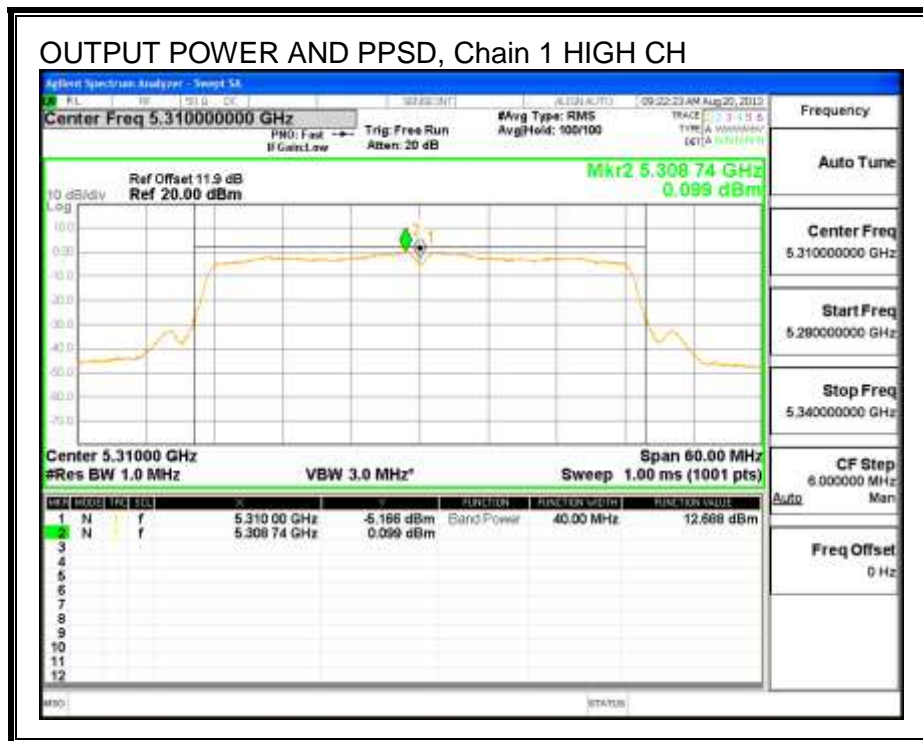
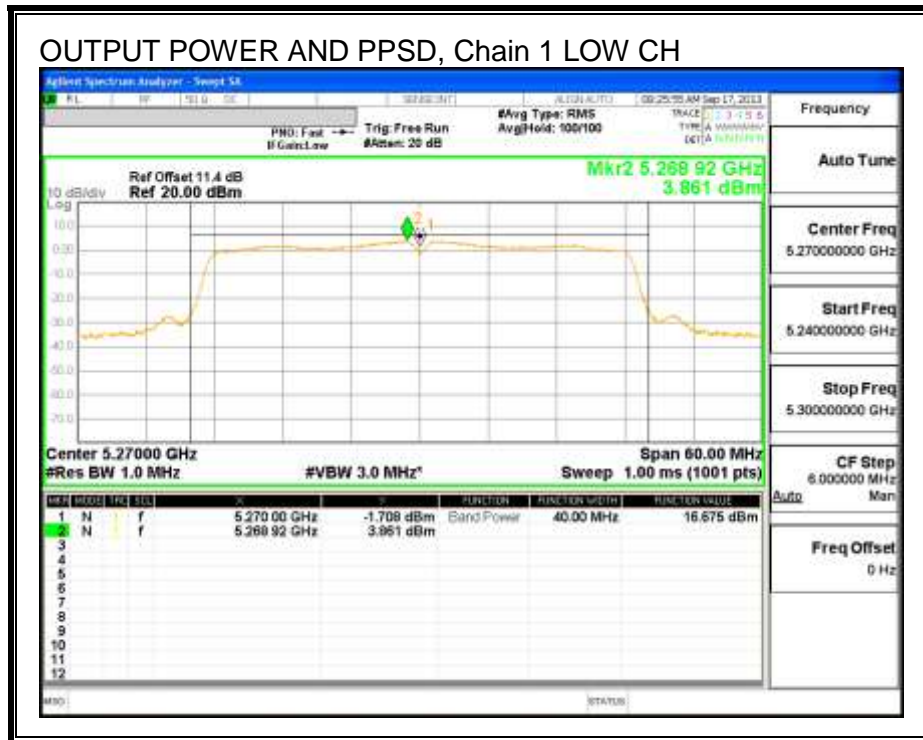

8.10.5. PEAK EXCURSION

LIMITS

FCC §15.407 (a) (6)

The ratio of the peak excursion of the modulation envelope (measured using a peak hold function) to the peak transmit power (measured as specified above) shall not exceed 13 dB across any 1 MHz bandwidth or the emission bandwidth whichever is less.

RESULTS

Chain 0

Channel	Frequency (MHz)	PK Level (dBm)	PSD (dBm)	DCCF (dB)	Peak Excursion (dB)	Limit (dB)	Margin (dB)
Mid	5270	11.71	4.15	0.00	7.56	13	-5.44

Chain 1

Channel	Frequency (MHz)	PK Level (dBm)	PSD (dBm)	DCCF (dB)	Peak Excursion (dB)	Limit (dB)	Margin (dB)
Mid	5270	12.36	3.51	0.00	8.85	13	-4.15

PEAK EXCURSION, Chain 0

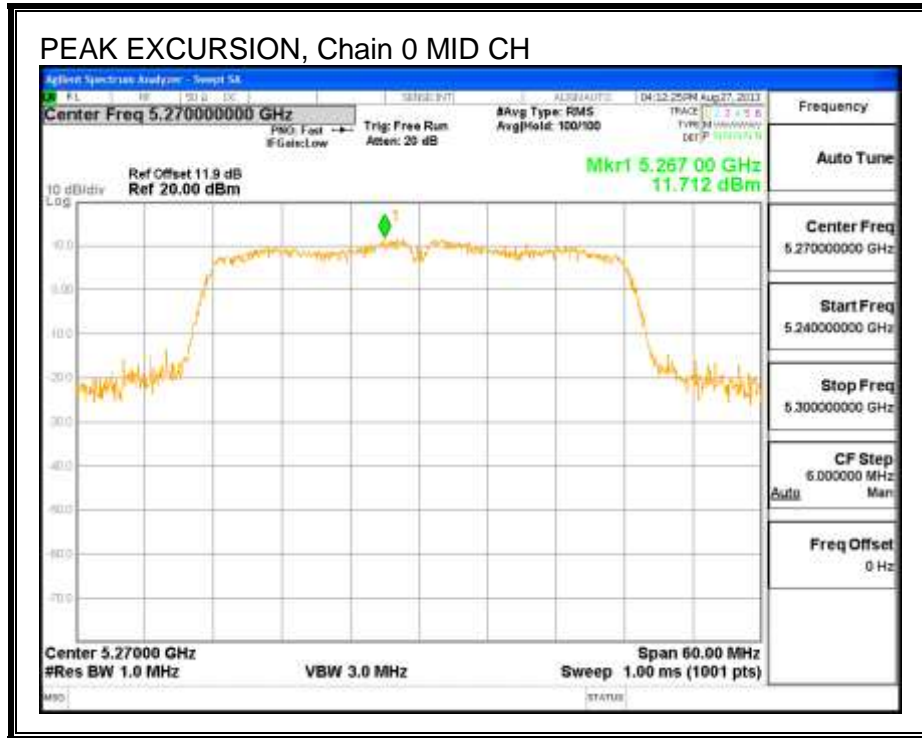

PEAK EXCURSION, Chain 1

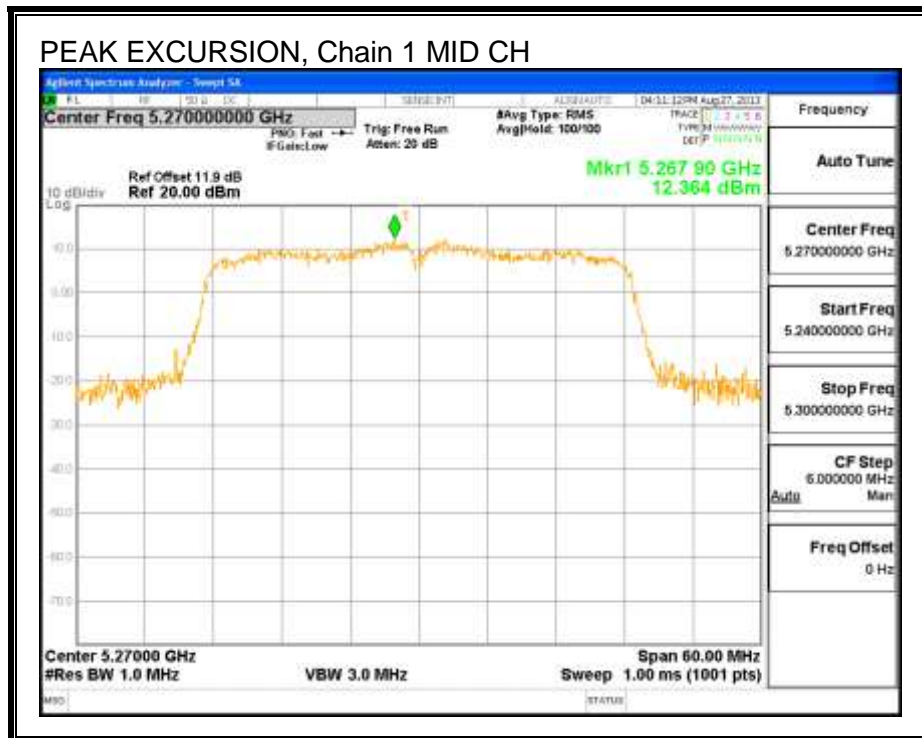

8.11. 802.11a SISO MODE IN THE 5.6 GHz BAND

8.11.1. 26 dB BANDWIDTH

LIMITS

None; for reporting purposes only.

RESULTS

Channel	Frequency (MHz)	26 dB Bandwidth (MHz)
Low	5500	20.50
Mid	5580	22.60
High	5700	20.33

26 dB BANDWIDTH

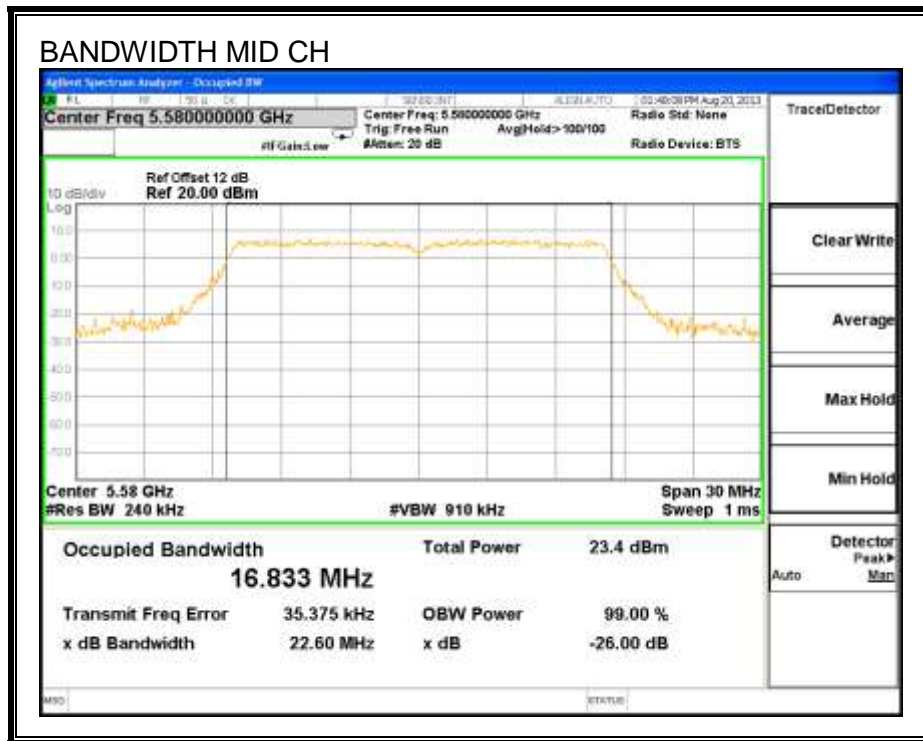
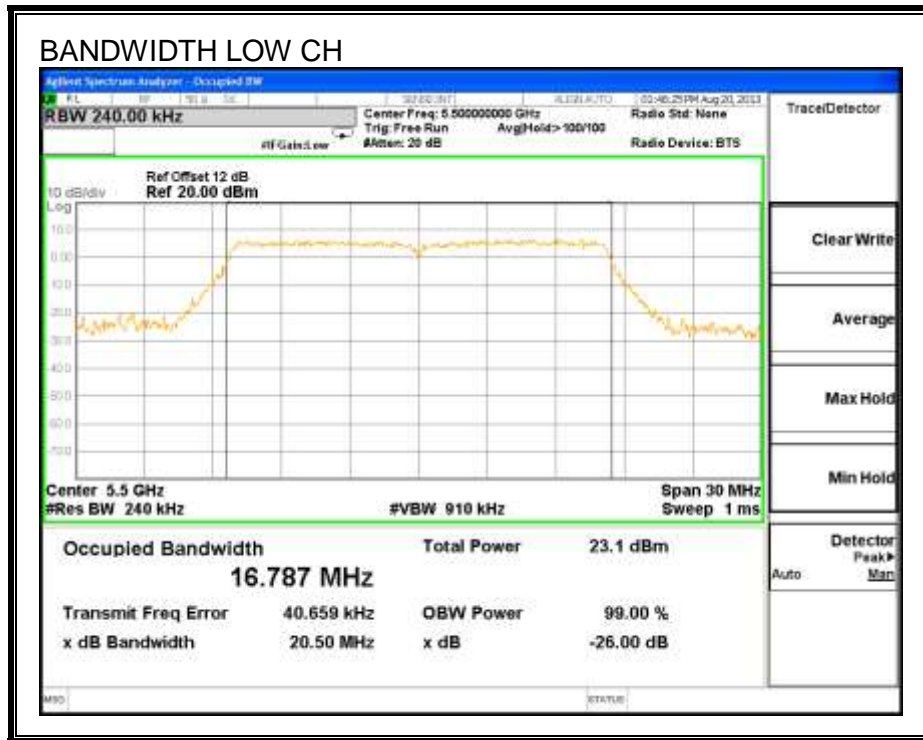

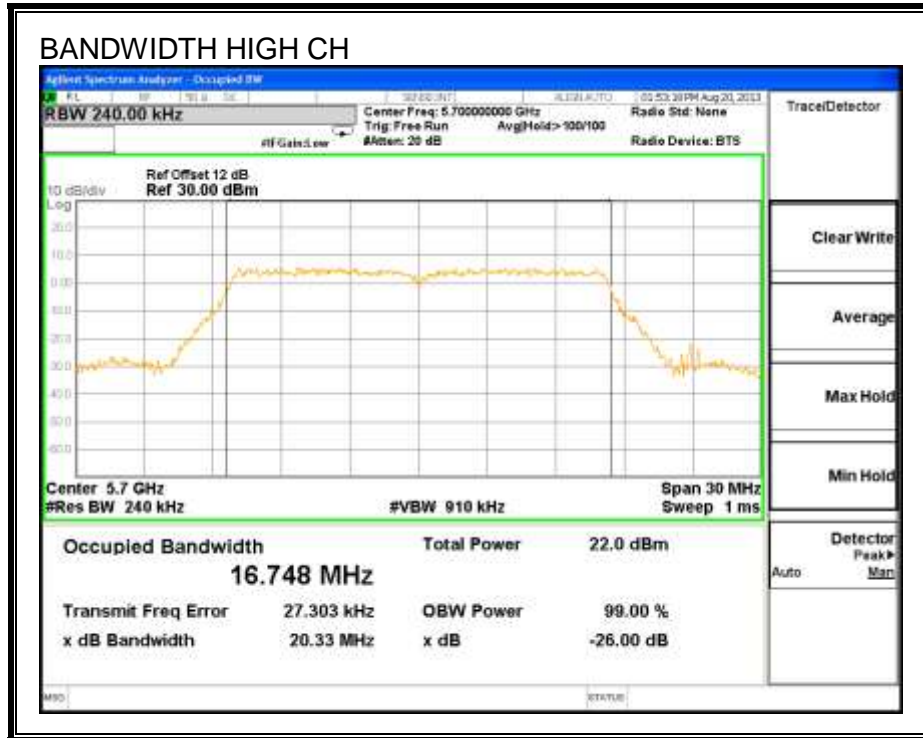

8.11.2. 99% BANDWIDTH

LIMITS

None; for reporting purposes only.

RESULTS

Channel	Frequency (MHz)	99% Bandwidth (MHz)
Low	5500	16.91
Mid	5580	16.83
High	5700	16.84

99% BANDWIDTH

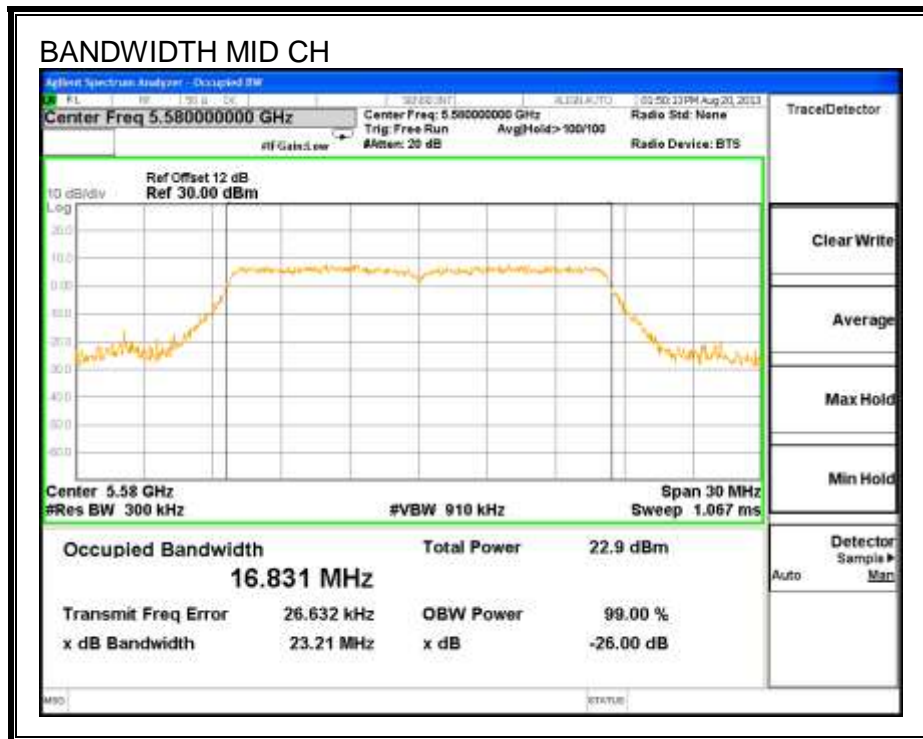
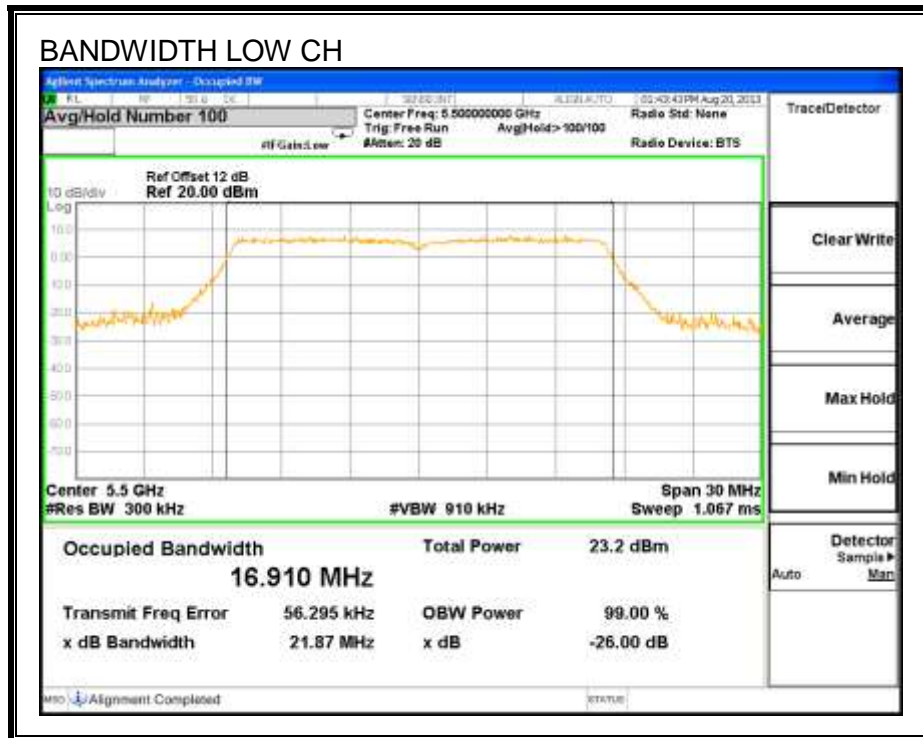

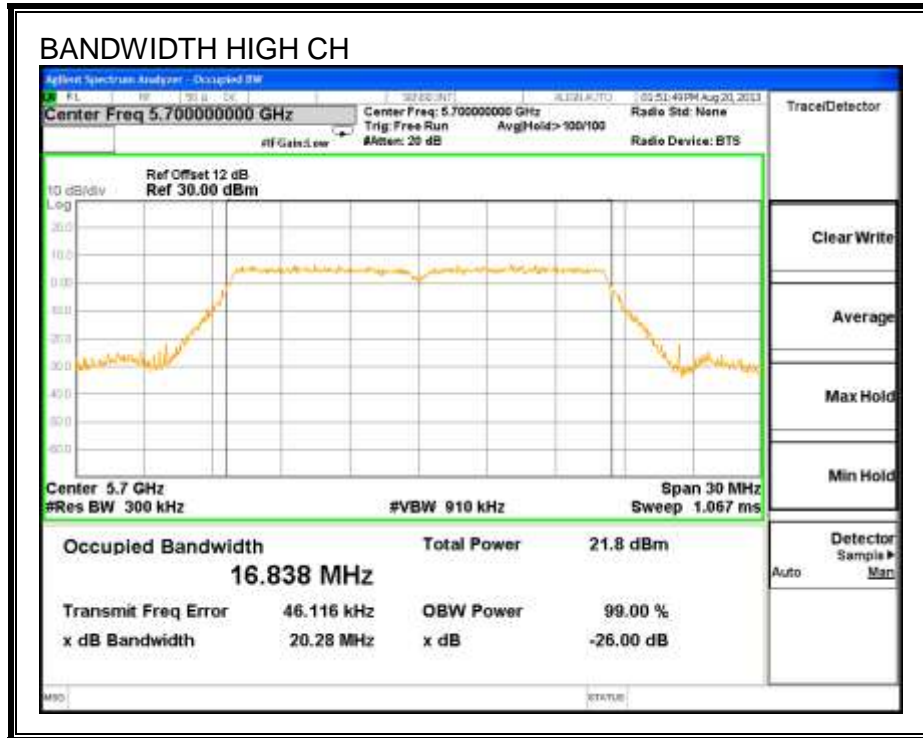

8.11.3. AVERAGE POWER

LIMITS

None; for reporting purposes only.

TEST PROCEDURE

The transmitter output is connected to a power meter.

The cable assembly insertion loss of 12 dB (including 10 dB pad and 2 dB cable) was entered as an offset in the power meter to allow for direct reading of power.

RESULTS

Channel	Frequency (MHz)	Power (dBm)
Low	5500	15.0
Mid	5580	16.5
High	5700	14.5

8.11.4. OUTPUT POWER AND PPSD

LIMITS

FCC §15.407 (a) (1)

For the band 5.5–5.7 GHz, the maximum conducted output power over the frequency band of operation shall not exceed the lesser of 250 mW or $11 \text{ dBm} + 10 \log B$, where B is the 26–dB emission bandwidth in MHz. In addition, the peak power spectral density shall not exceed 11 dBm in any 1–MHz band. If transmitting antennas of directional gain greater than 6 dBi are used, both the maximum conducted output power and the peak power spectral density shall be reduced by the amount in dB that the directional gain of the antenna exceeds 6 dBi.

IC RSS-210 A9.2 (1)

The maximum e.i.r.p. shall not exceed 200 mW or $10 + 10 \log_{10} B$, dBm, whichever power is less. B is the 99% emission bandwidth in MHz. The e.i.r.p. spectral density shall not exceed 10 dBm in any 1.0 MHz band.

DIRECTIONAL ANTENNA GAIN

There is only one transmitter output therefore the directional gain is equal to the antenna gain.

RESULTS

Bandwidth and Antenna Gain

Channel	Frequency (MHz)	Min 26 dB BW (MHz)	Min 99% BW (MHz)	Directional Gain (dBi)
Low	5500	20.5	16.9	3.66
Mid	5580	22.6	16.8	3.66
High	5700	20.3	16.8	3.66

Limits

Channel	Frequency (MHz)	FCC Power Limit (dBm)	IC Power Limit (dBm)	IC EIRP Limit (dBm)	Power Limit (dBm)	FCC PPSD Limit (dBm)	IC PSD Limit (dBm)	PPSD Limit (dBm)
Low	5500	24.00	23.28	29.28	23.28	11.00	11.00	11.00
Mid	5580	24.00	23.26	29.26	23.26	11.00	11.00	11.00
High	5700	24.00	23.26	29.26	23.26	11.00	11.00	11.00

Duty Cycle CF (dB)	0.00	Included in Calculations of Corr'd Power & PPSD
---------------------------	------	--

Output Power Results

Channel	Frequency (MHz)	Chain 0 Meas Power (dBm)	Total Corr'd Power (dBm)	Power Limit (dBm)	Power Margin (dB)
Low	5500	15.14	15.14	23.28	-8.15
Mid	5580	16.67	16.67	23.26	-6.60
High	5700	14.66	14.66	23.26	-8.61

PPSD Results

Channel	Frequency (MHz)	Chain 0 Meas PPSD (dBm)	Total Corr'd PPSD (dBm)	PPSD Limit (dBm)	PPSD Margin (dB)
Low	5500	4.04	4.04	11.00	-6.96
Mid	5580	5.07	5.07	11.00	-5.93
High	5700	3.61	3.61	11.00	-7.39

OUTPUT POWER AND PPSD, Chain 0

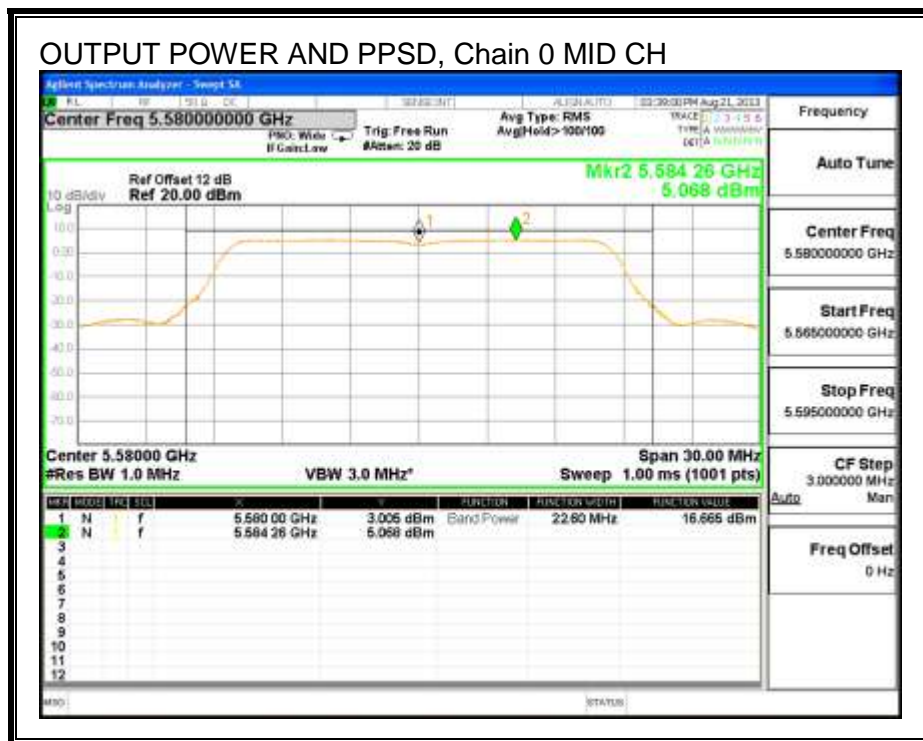
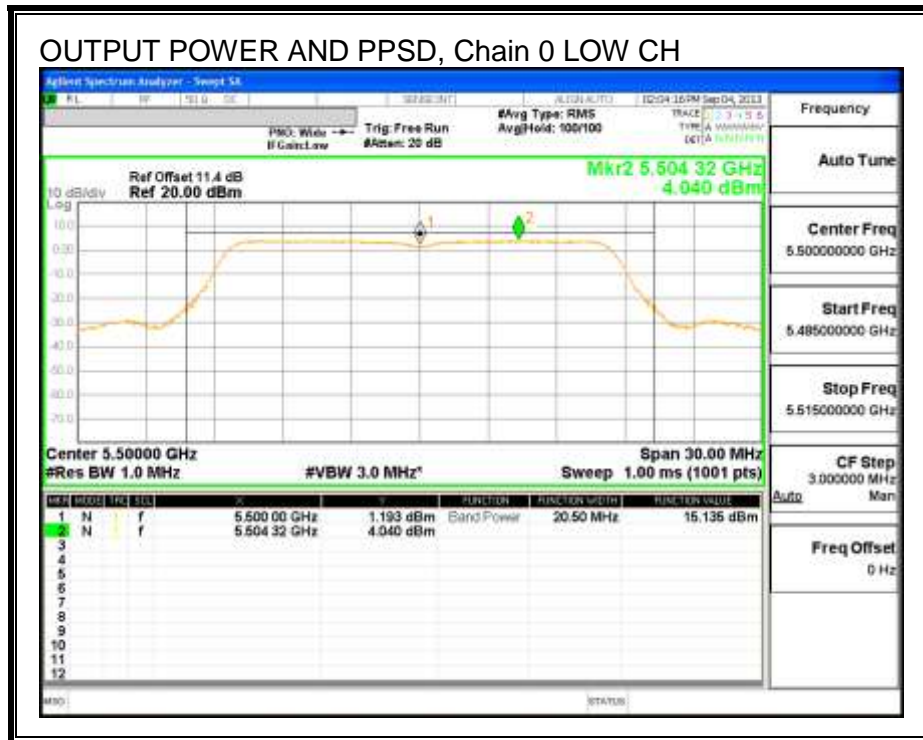

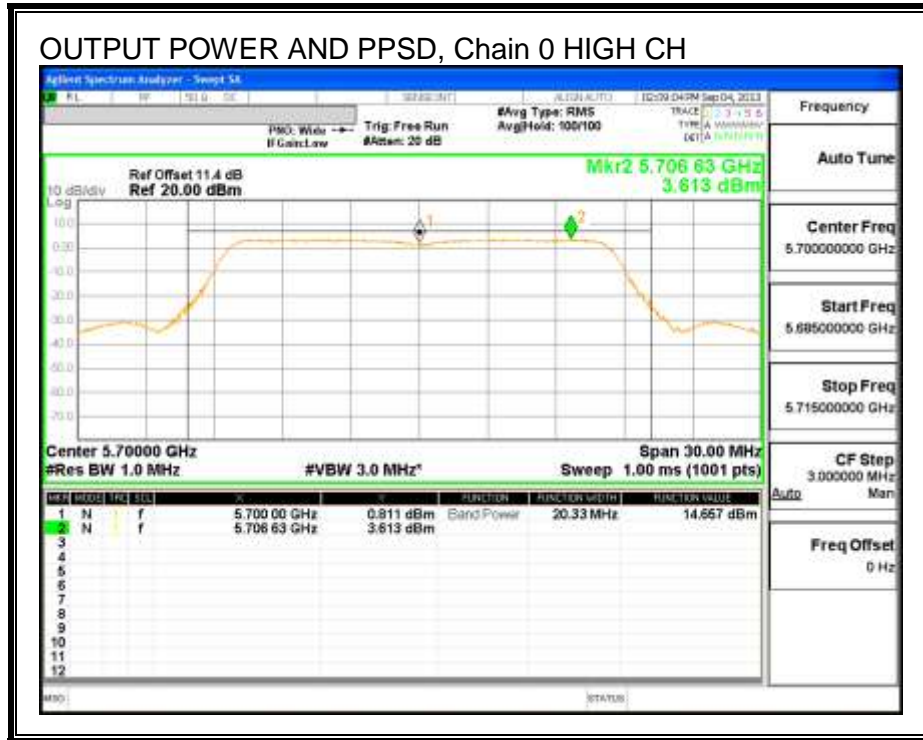

8.11.5. PEAK EXCURSION

LIMITS

FCC §15.407 (a) (6)

The ratio of the peak excursion of the modulation envelope (measured using a peak hold function) to the peak transmit power (measured as specified above) shall not exceed 13 dB across any 1 MHz bandwidth or the emission bandwidth whichever is less.

RESULTS

Channel	Frequency (MHz)	PK Level (dBm)	PSD (dBm)	DCCF (dB)	Peak Excursion (dB)	Limit (dB)	Margin (dB)
Mid	5580	13.39	5.07	0.00	8.32	13	-4.68

PEAK EXCURSION

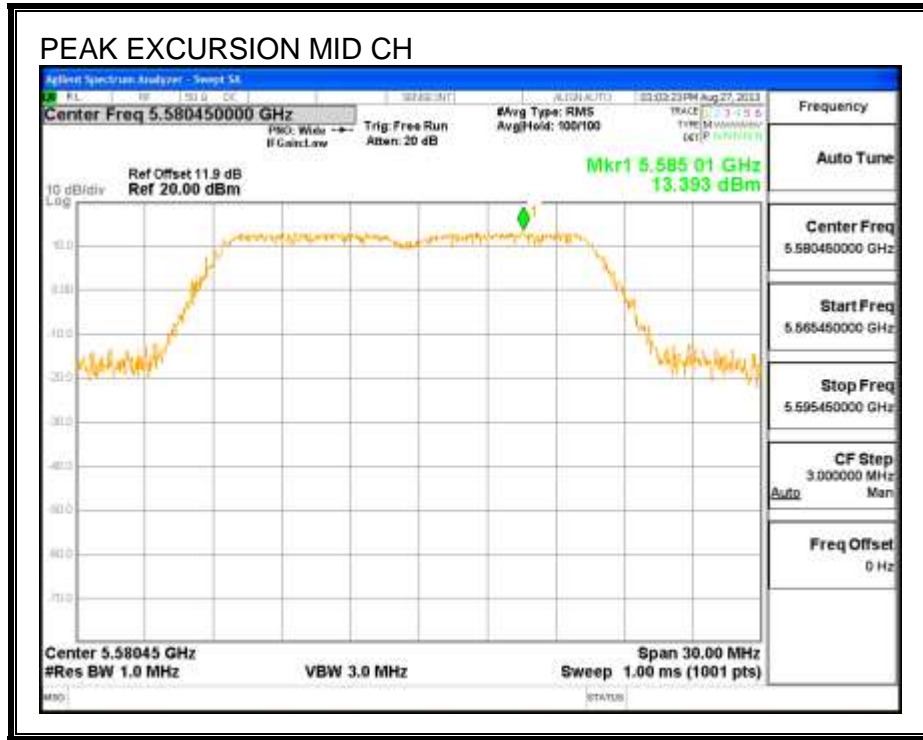

8.12. 802.11n HT20 2TX CDD MODE IN THE 5.6 GHZ BAND

8.12.1. 26 dB BANDWIDTH

LIMITS

None; for reporting purposes only.

RESULTS

Channel	Frequency (MHz)	26 dB BW Chain 0 (MHz)	26 dB BW Chain 1 (MHz)
Low	5500	20.50	20.59
Mid	5580	20.83	20.38
High	5700	20.34	20.39

26 dB BANDWIDTH, Chain 0

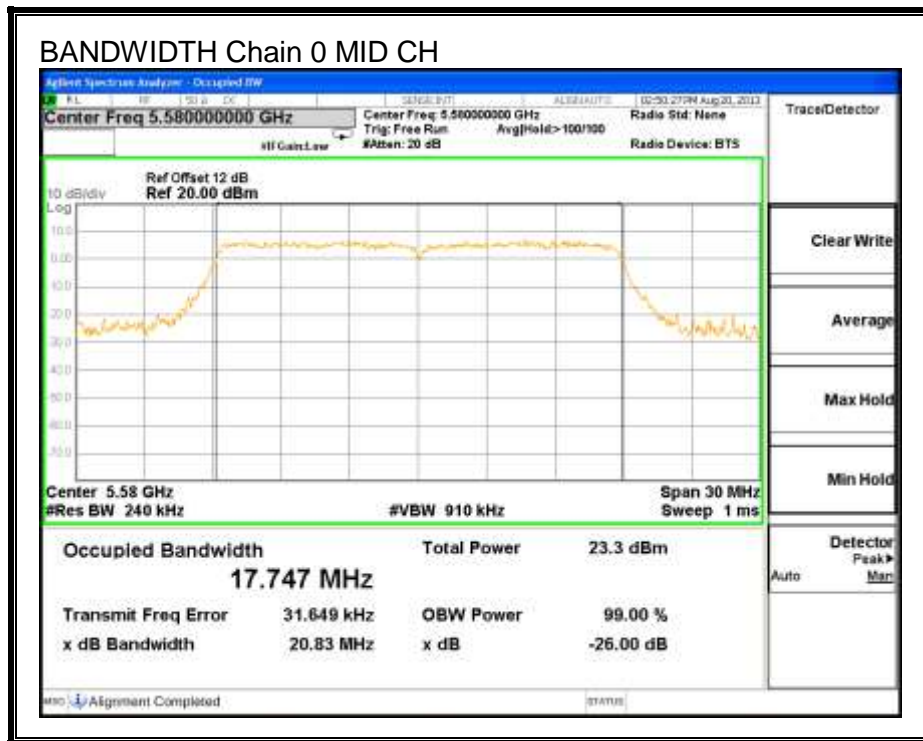
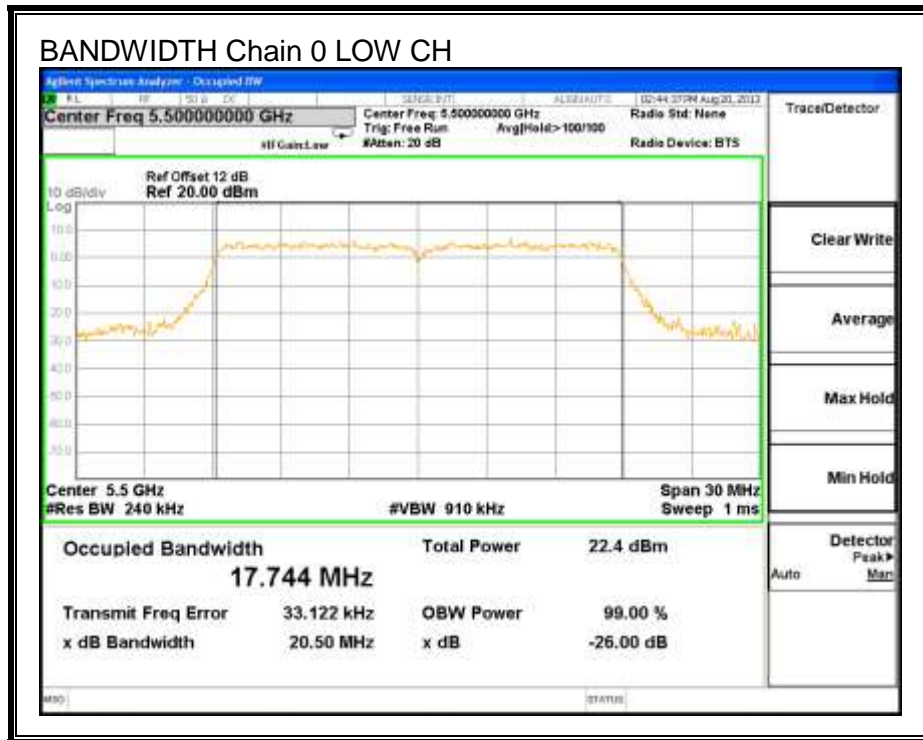

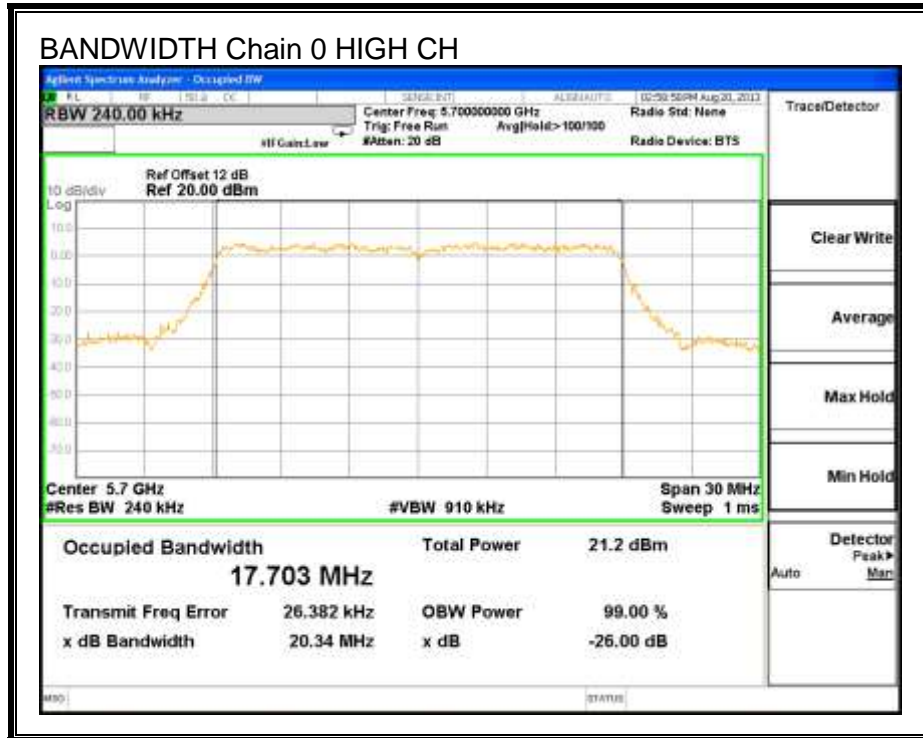

26 dB BANDWIDTH, Chain 1

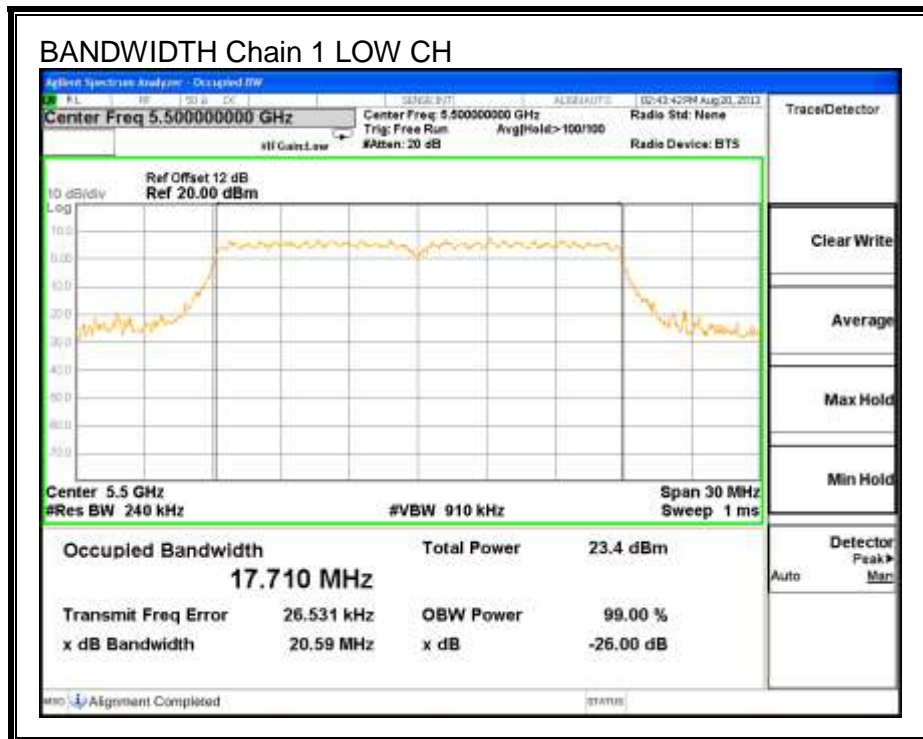

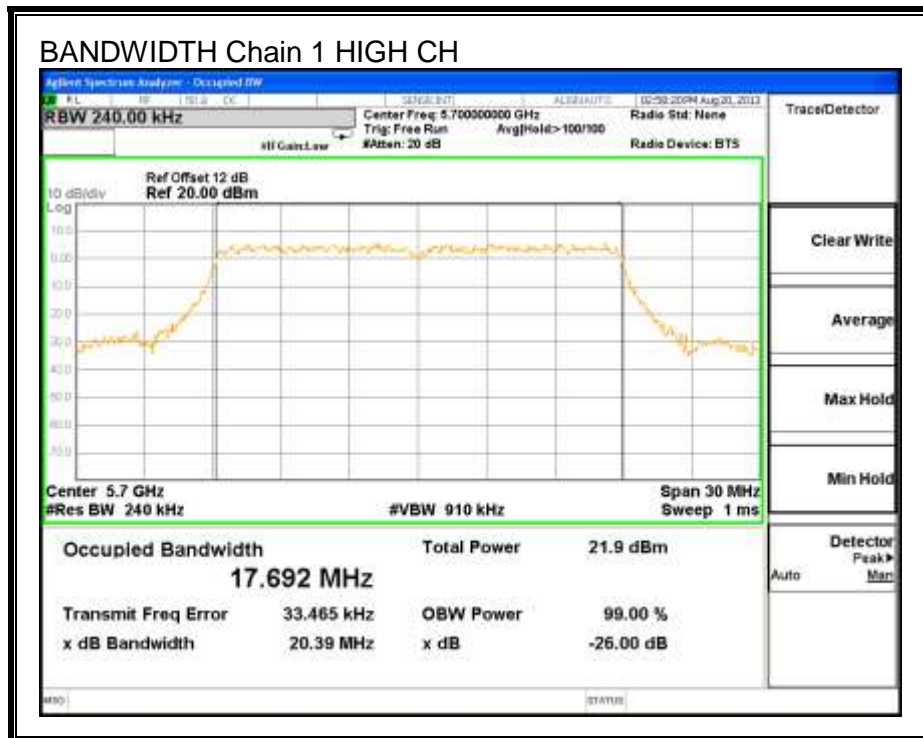
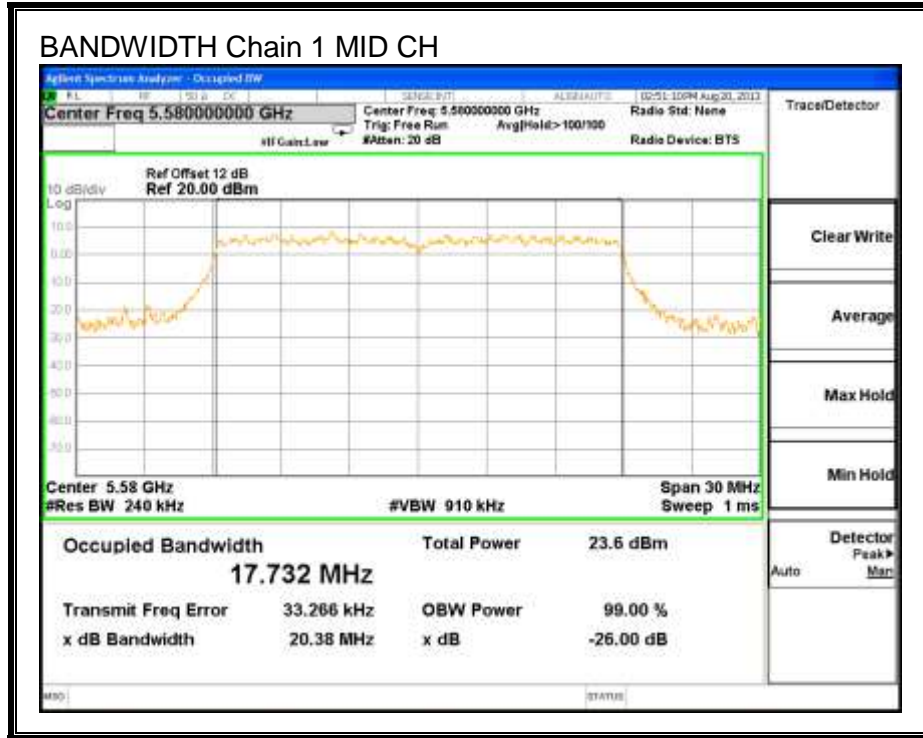

8.12.2. 99% BANDWIDTH

LIMITS

None; for reporting purposes only.

RESULTS

Channel	Frequency (MHz)	99% BW Chain 0 (MHz)	99% BW Chain 1 (MHz)
Low	5500	17.80	17.76
Mid	5580	17.80	17.76
High	5700	17.74	17.75

99% BANDWIDTH, Chain 0

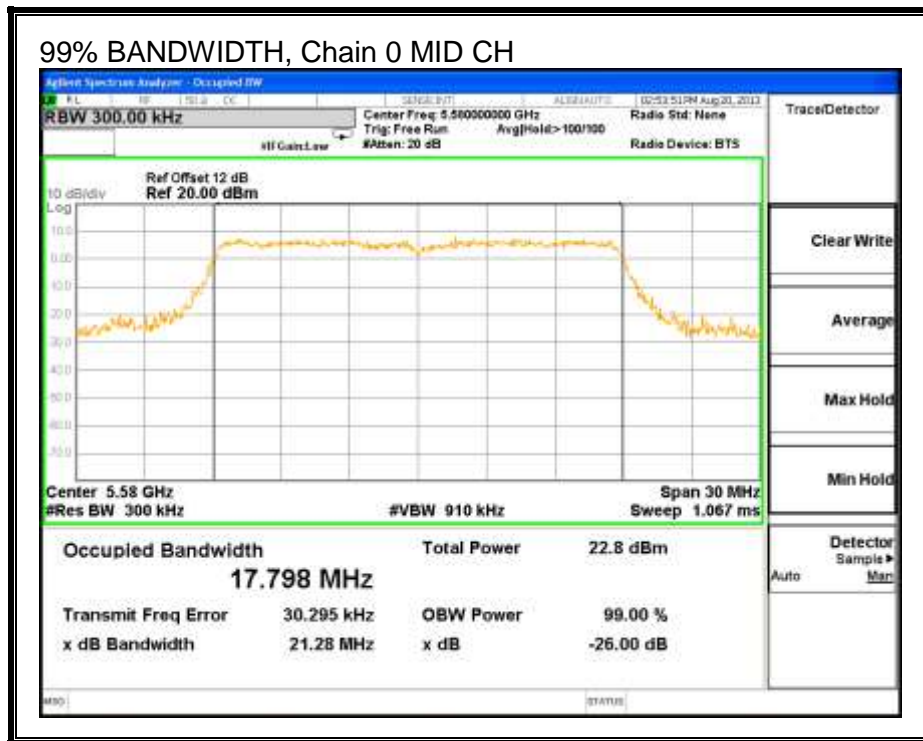
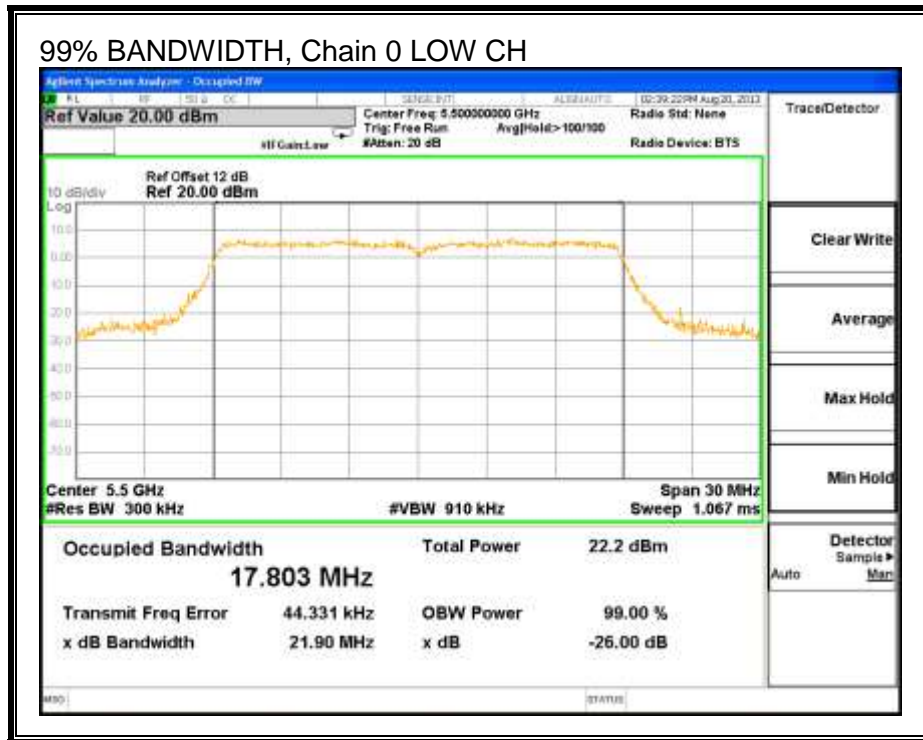

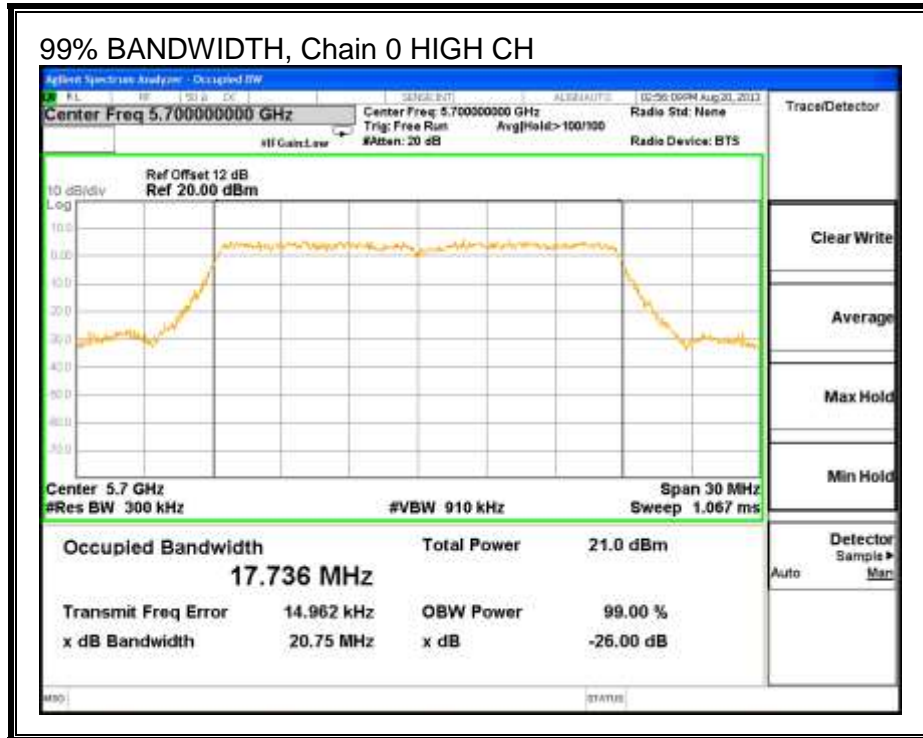

99% BANDWIDTH, Chain 1

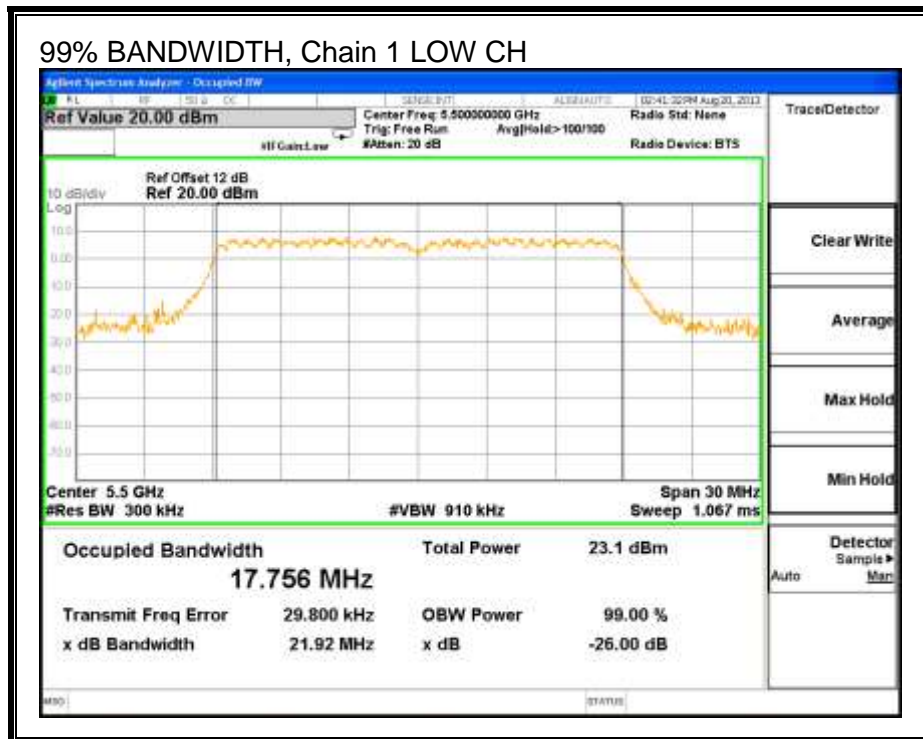

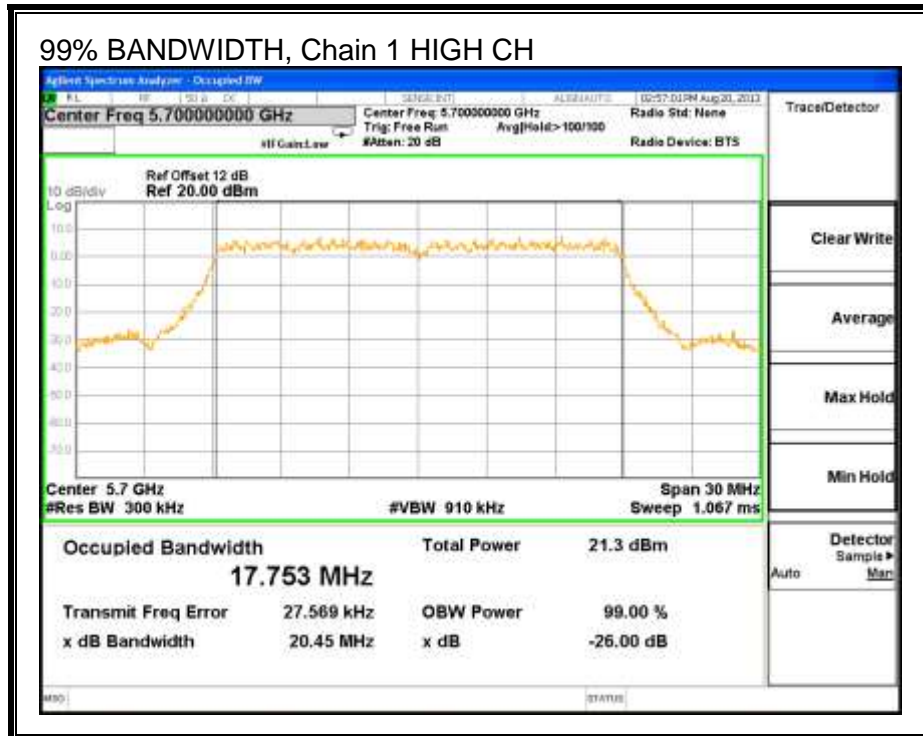
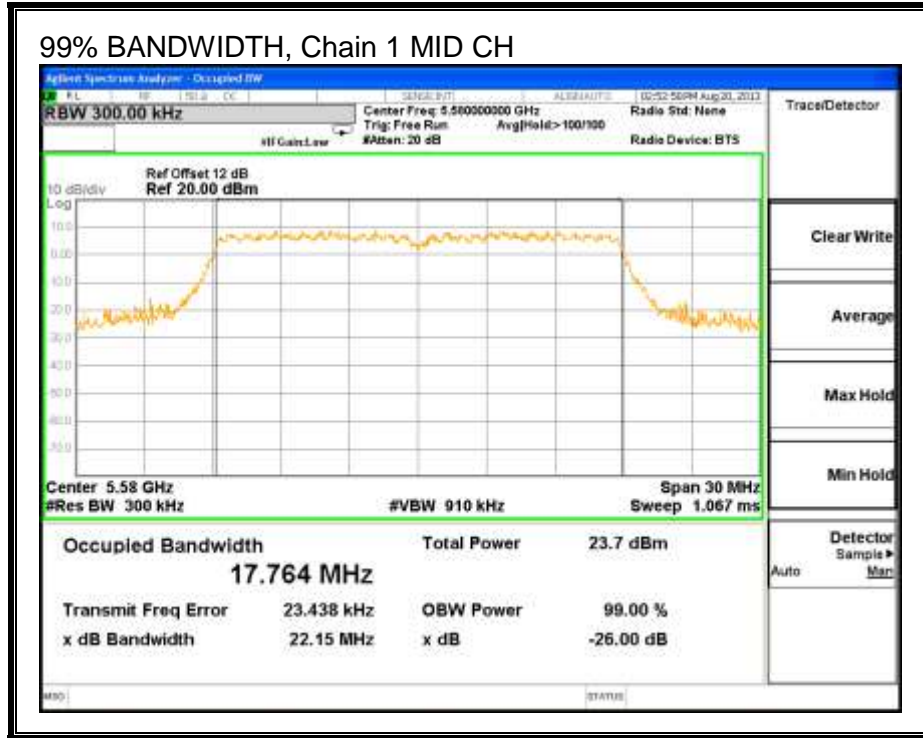

8.12.3. AVERAGE POWER

LIMITS

None; for reporting purposes only.

TEST PROCEDURE

The transmitter output is connected to a power meter.

The cable assembly insertion loss of 12 dB (including 10 dB pad and 2 dB cable) was entered as an offset in the power meter to allow for direct reading of power.

RESULTS

Average Power Results

Channel	Frequency (MHz)	Chain 0 Power (dBm)	Chain 1 Power (dBm)	Total Power (dBm)
Low	5500	14.00	13.88	16.95
Mid	5580	15.84	16.00	18.93
High	5700	13.00	13.00	16.01

8.12.4. OUTPUT POWER AND PPSD

LIMITS

FCC §15.407 (a) (1)

For the band 5.5–5.7 GHz, the maximum conducted output power over the frequency band of operation shall not exceed the lesser of 250 mW or 11 dBm + 10 log B, where B is the 26–dB emission bandwidth in MHz. In addition, the peak power spectral density shall not exceed 11 dBm in any 1–MHz band. If transmitting antennas of directional gain greater than 6 dBi are used, both the maximum conducted output power and the peak power spectral density shall be reduced by the amount in dB that the directional gain of the antenna exceeds 6 dBi.

IC RSS-210 A9.2 (1)

The maximum e.i.r.p. shall not exceed 200 mW or 10 + 10 log₁₀ B, dBm, whichever power is less. B is the 99% emission bandwidth in MHz. The e.i.r.p. spectral density shall not exceed 10 dBm in any 1.0 MHz band.

DIRECTIONAL ANTENNA GAIN

For output power, the TX chains are uncorrelated and the antenna gain is unequal among the chains. The directional gain is:

Chain 0 Antenna Gain (dBi)	Chain 1 Antenna Gain (dBi)	Uncorrelated Chains Directional Gain (dBi)
3.66	3.99	3.83

For PPSD, the TX chains are correlated and the antenna gain is unequal among the chains. The directional gain is:

Chain 0 Antenna Gain (dBi)	Chain 1 Antenna Gain (dBi)	Correlated Chains Directional Gain (dBi)
3.66	3.99	6.84

RESULTS

Bandwidth and Antenna Gain

Channel	Frequency (MHz)	Min 26 dB BW (MHz)	Min 99% BW (MHz)	Uncorrelated Directional Gain (dBi)	Correlated Directional Gain (dBi)
Low	5500	20.5	17.8	3.83	6.84
Mid	5580	20.4	17.8	3.83	6.84
High	5700	20.3	17.7	3.83	6.84

Limits

Channel	Frequency (MHz)	FCC Power Limit (dBm)	IC Power Limit (dBm)	IC EIRP Limit (dBm)	Power Limit (dBm)	FCC PPSD Limit (dBm)	IC PSD Limit (dBm)	PPSD Limit (dBm)
Low	5500	24.00	23.49	29.49	23.49	10.16	11.00	10.16
Mid	5580	24.00	23.49	29.49	23.49	10.16	11.00	10.16
High	5700	24.00	23.49	29.49	23.49	10.16	11.00	10.16

Duty Cycle CF (dB)	0.00	Included in Calculations of Corr'd Power & PPSP
---------------------------	------	--

Output Power Results

Channel	Frequency (MHz)	Chain 0 Meas Power (dBm)	Chain 1 Meas Power (dBm)	Total Corr'd Power (dBm)	Power Limit (dBm)	Power Margi n (dB)
Low	5500	14.15	13.92	17.05	23.49	-6.45
Mid	5580	16.02	16.24	19.14	23.49	-4.35
High	5700	13.23	13.20	16.23	23.49	-7.26

PPSD Results

Channel	Frequency (MHz)	Chain 0 Meas PPSD (dBm)	Chain 1 Meas PPSD (dBm)	Total Corr'd PPSD (dBm)	PPSD Limit (dBm)	PPSD Margi n (dB)
Low	5500	2.83	2.54	5.70	10.16	-4.46
Mid	5580	4.73	4.09	7.43	10.16	-2.73
High	5700	1.94	1.86	4.91	10.16	-5.25

OUTPUT POWER AND PPSD, Chain 0

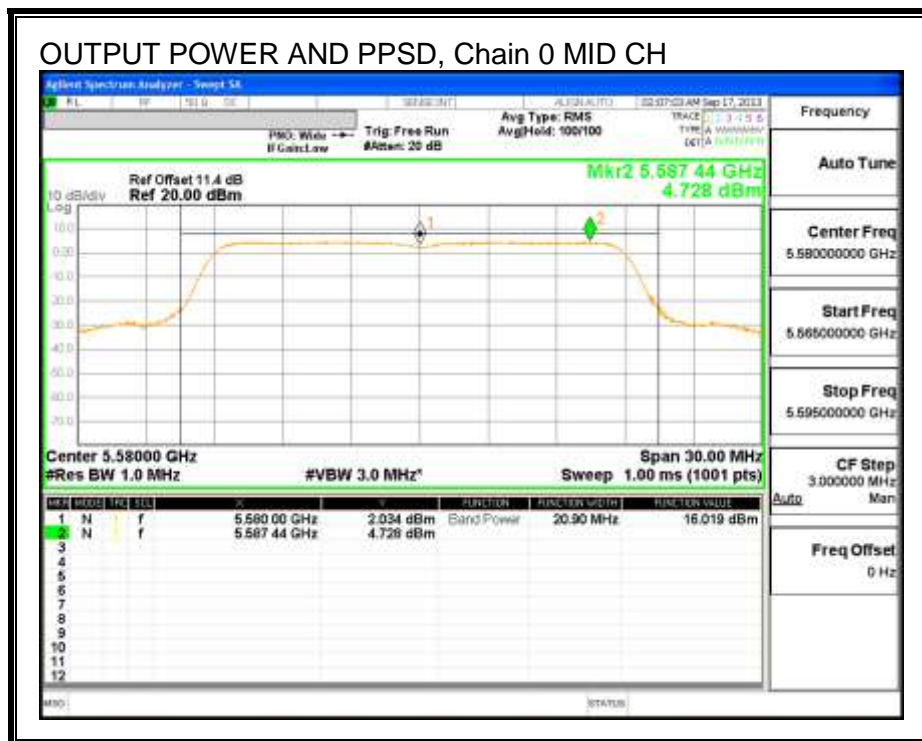
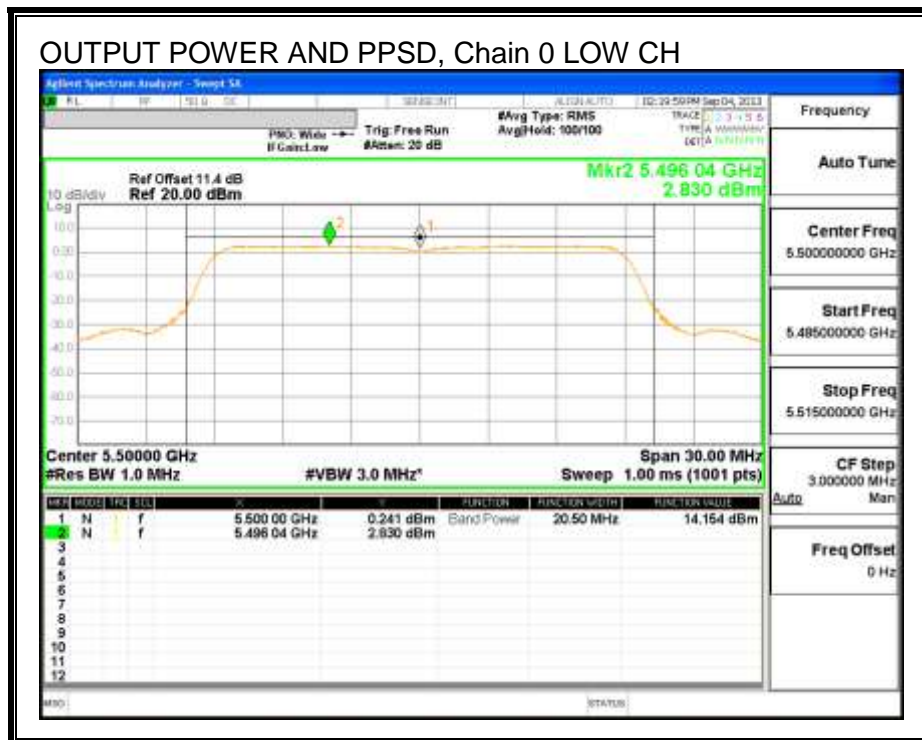

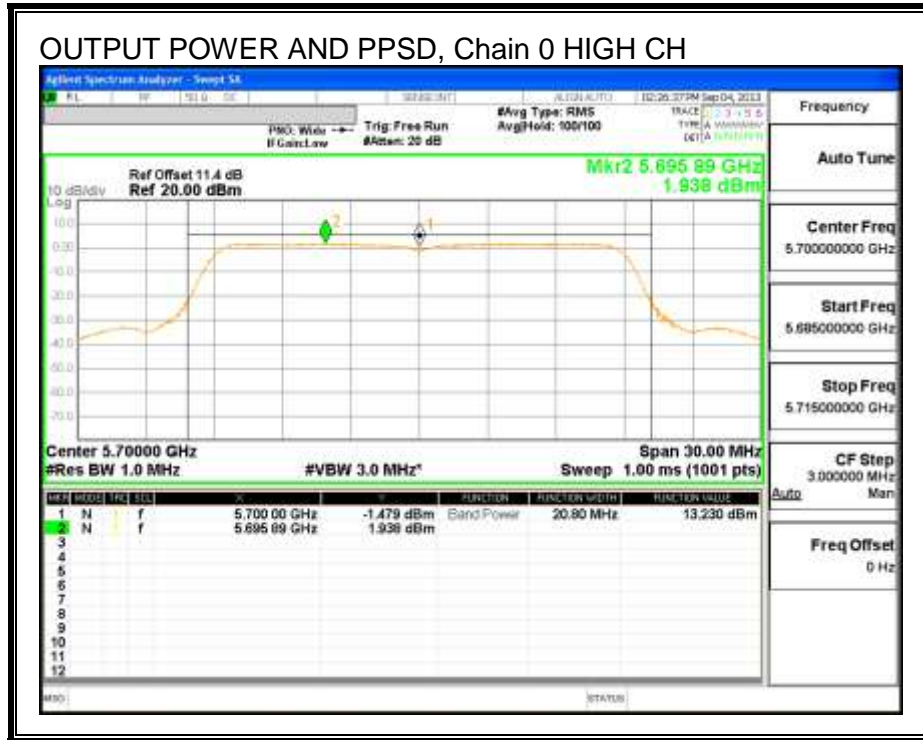

OUTPUT POWER AND PPSD, Chain 1

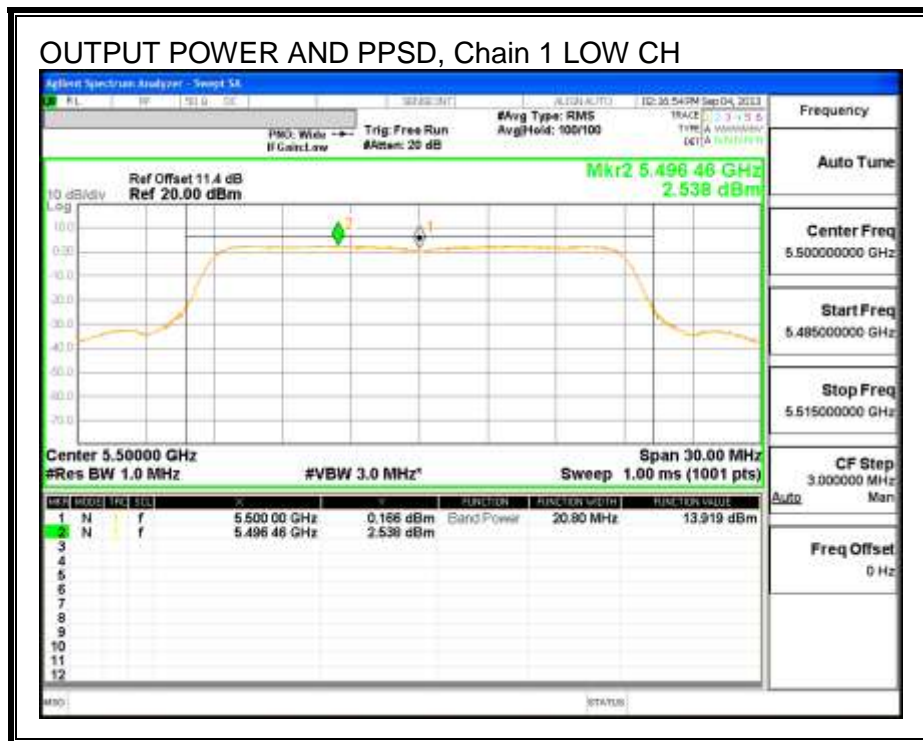

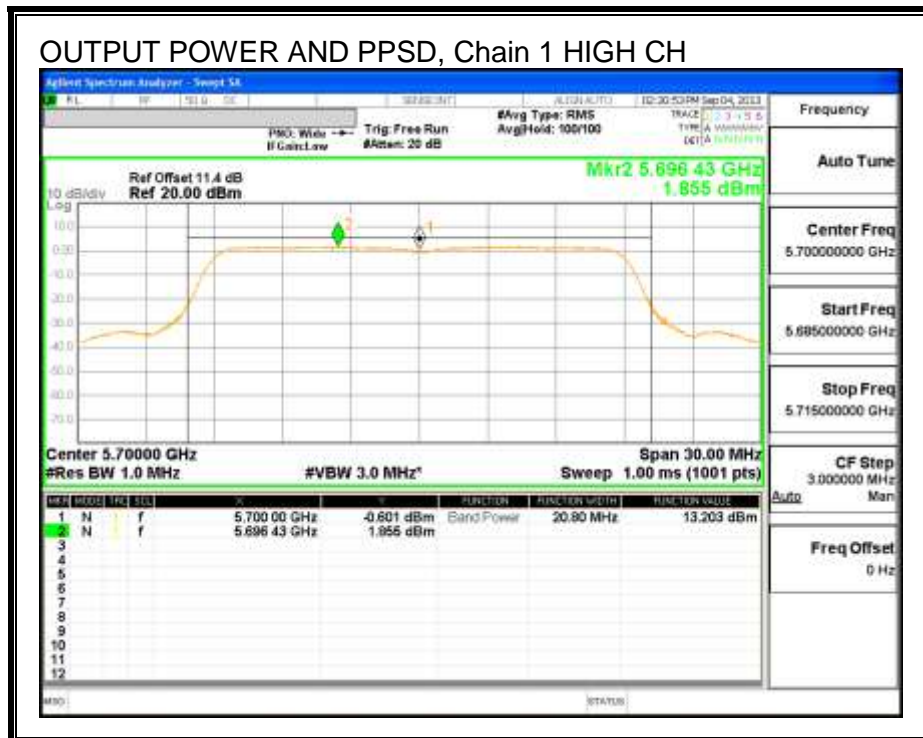
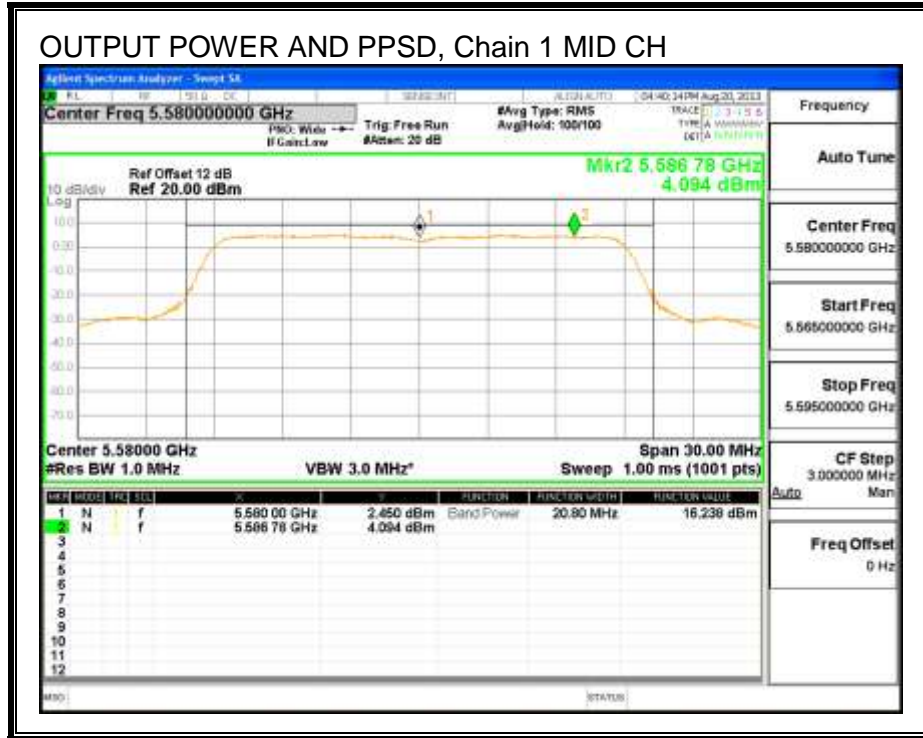

8.12.5. PEAK EXCURSION

LIMITS

FCC §15.407 (a) (6)

The ratio of the peak excursion of the modulation envelope (measured using a peak hold function) to the peak transmit power (measured as specified above) shall not exceed 13 dB across any 1 MHz bandwidth or the emission bandwidth whichever is less.

RESULTS

Chain 0

Channel	Frequency (MHz)	PK Level (dBm)	PSD (dBm)	DCCF (dB)	Peak Excursion (dB)	Limit (dB)	Margin (dB)
Mid	5580	11.96	5.03	0.00	6.93	13	-6.07

Chain 1

Channel	Frequency (MHz)	PK Level (dBm)	PSD (dBm)	DCCF (dB)	Peak Excursion (dB)	Limit (dB)	Margin (dB)
Mid	5580	13.50	4.09	0.00	9.41	13	-3.59

PEAK EXCURSION, Chain 0

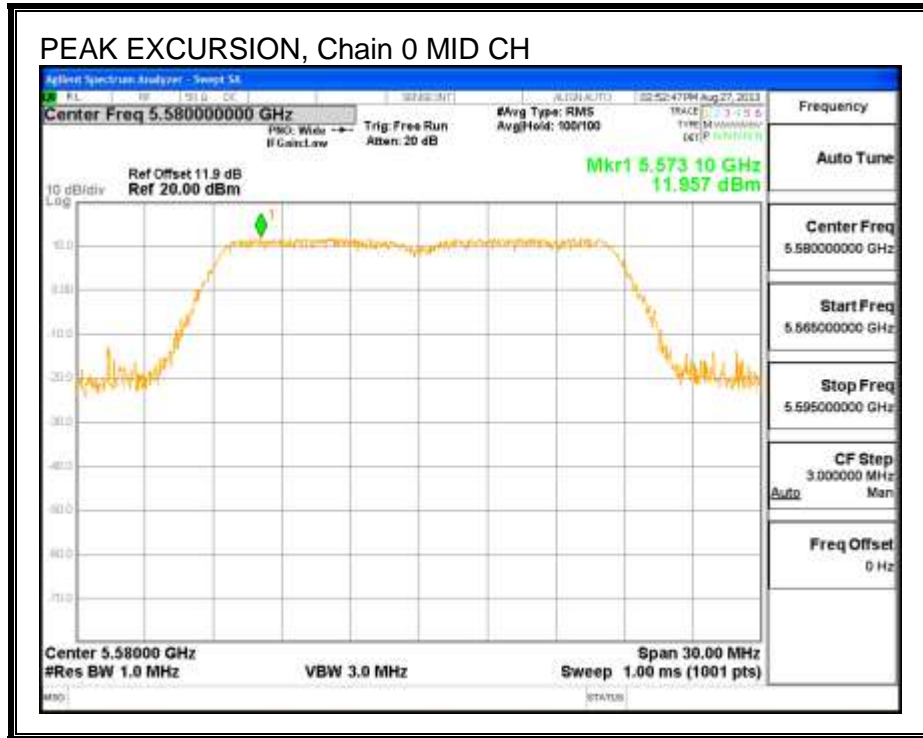

8.13. 802.11n HT20 2TX STBC MODE IN THE 5.6 GHz BAND

8.13.1. 26 dB BANDWIDTH

LIMITS

None; for reporting purposes only.

RESULTS

Channel	Frequency (MHz)	26 dB BW Chain 0 (MHz)	26 dB BW Chain 1 (MHz)
Mid	5580	21.00	21.07

26 dB BANDWIDTH

26 dB BANDWIDTH, Chain 0

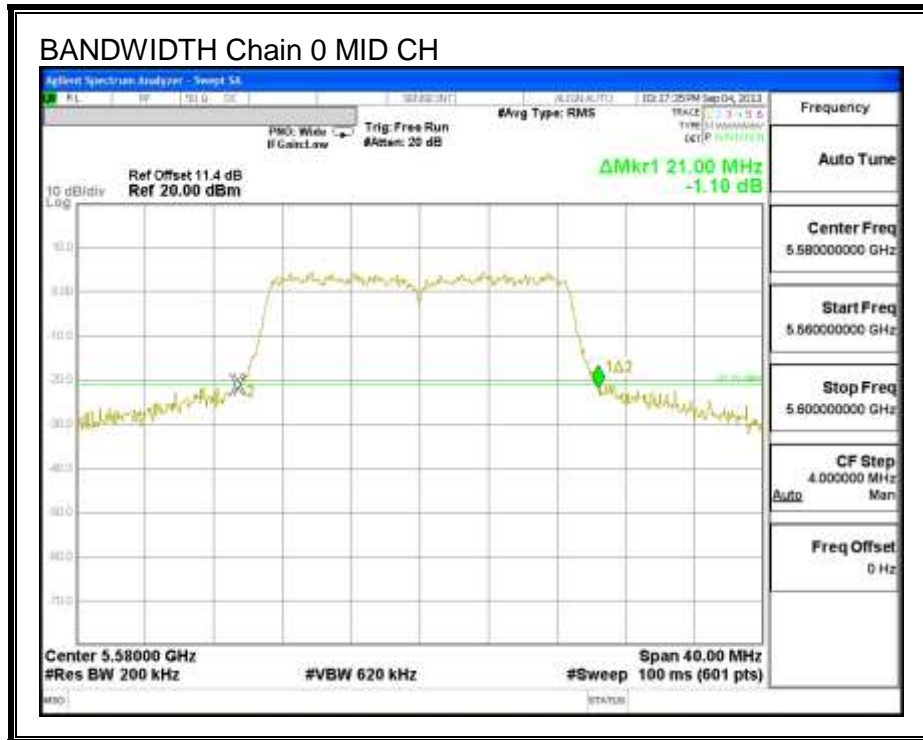

26 dB BANDWIDTH, Chain 1

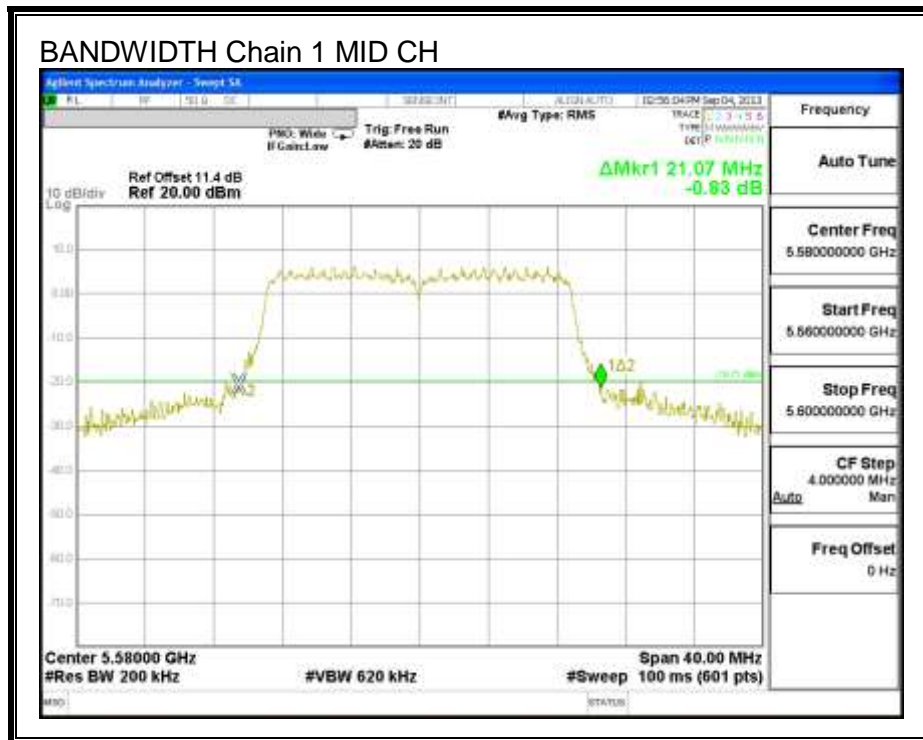

8.13.2. 99% BANDWIDTH

LIMITS

None; for reporting purposes only.

RESULTS

Channel	Frequency (MHz)	99% BW Chain 0 (MHz)	99% BW Chain 1 (MHz)
Mid	5580	17.6790	17.7050

99% BANDWIDTH

99% BANDWIDTH, Chain 0

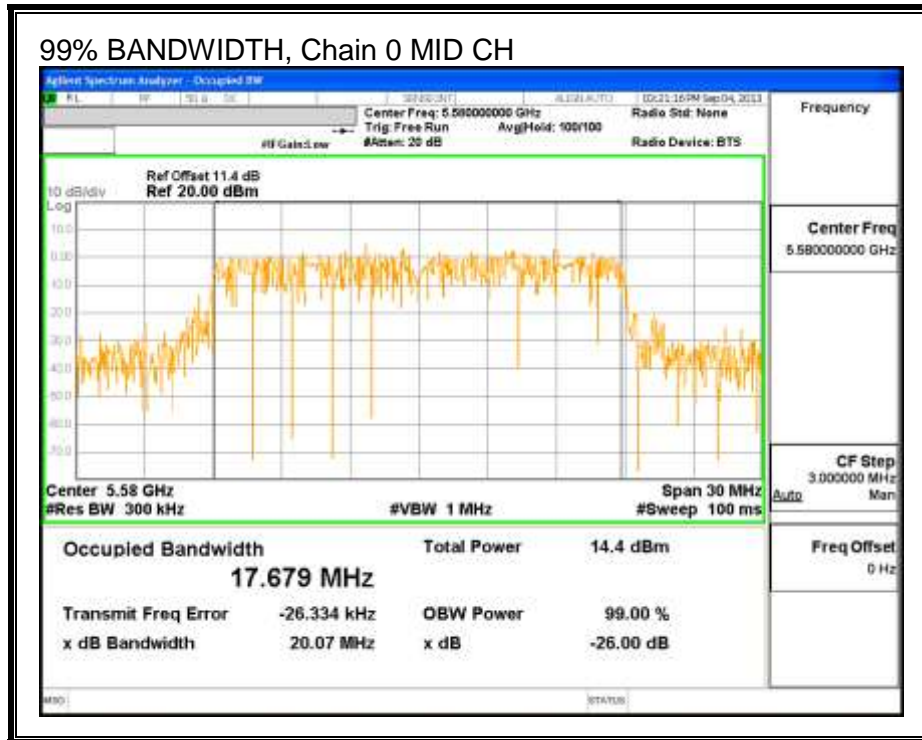

99% BANDWIDTH, Chain 1

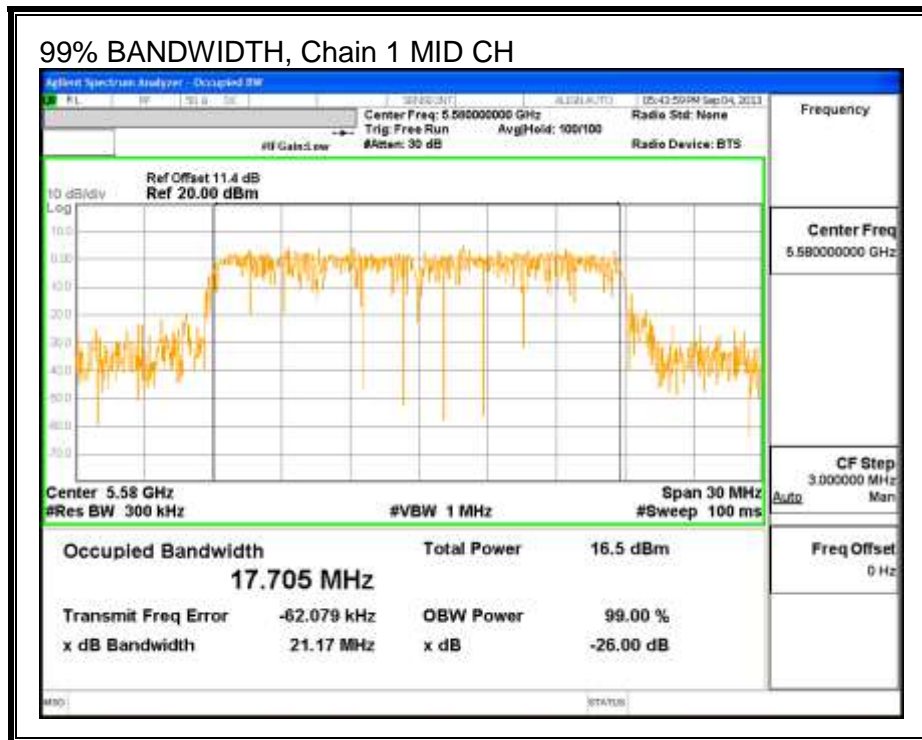

8.13.3. AVERAGE POWER

LIMITS

None; for reporting purposes only.

TEST PROCEDURE

The transmitter output is connected to a power meter.

The cable assembly insertion loss of 12 dB (including 10 dB pad and 2 dB cable) was entered as an offset in the power meter to allow for direct reading of power.

RESULTS

Average Power Results

Channel	Frequency (MHz)	Chain 0 Power (dBm)	Chain 1 Power (dBm)	Total Power (dBm)
Mid	5580	16.50	16.42	19.47