



**FCC CFR47 PART 15 SUBPART C
INDUSTRY CANADA RSS-210 ISSUE 8**

**BLUETOOTH LOW ENERGY
CERTIFICATION TEST REPORT**

FOR

The Apple iPad is a tablet device with multimedia functions (music, application support, and video), 802.11a/b/g/n radio, and Bluetooth radio functions

MODEL NUMBER: A1432, A1454, & A1455*

**FCC ID: BCGA1432
IC: 579C-A1432**

REPORT NUMBER: 12U14526-4, Revision A

ISSUE DATE: OCTOBER 03, 2012

Prepared for
**APPLE, INC.
1 INFINITE LOOP
CUPERTINO, CA 95014, U.S.A**

Prepared by
**UL CCS
47173 BENICIA STREET
FREMONT, CA 94538, U.S.A.
TEL: (510) 771-1000
FAX: (510) 661-0888**

*Models differences are detailed within the body of this report



NVLAP LAB CODE 200065-0

Revision History

<u>Rev.</u>	<u>Issue Date</u>	<u>Revisions</u>	<u>Revised By</u>
--	09/04/12	Initial Issue	F. Ibrahim
A	10/03/12	Updated Description of Model Differences section	A. Zaffar

TABLE OF CONTENTS

1. ATTESTATION OF TEST RESULTS	4
2. TEST METHODOLOGY	5
3. FACILITIES AND ACCREDITATION	5
4. CALIBRATION AND UNCERTAINTY	5
4.1. MEASURING INSTRUMENT CALIBRATION	5
4.2. SAMPLE CALCULATION	5
4.3. MEASUREMENT UNCERTAINTY	5
5. EQUIPMENT UNDER TEST	6
5.1. DESCRIPTION OF EUT	6
5.2. DESCRIPTION OF MODELS DIFFERENCES	6
5.3. MAXIMUM OUTPUT POWER	6
5.4. DESCRIPTION OF AVAILABLE ANTENNAS	7
5.5. SOFTWARE AND FIRMWARE	7
5.6. WORST-CASE CONFIGURATION AND MODE	8
5.7. DESCRIPTION OF TEST SETUP	9
6. TEST AND MEASUREMENT EQUIPMENT	11
7. ANTENNA PORT TEST RESULTS	12
7.1. 6 dB BANDWIDTH	12
7.2. 99% BANDWIDTH	16
7.3. OUTPUT POWER	20
7.4. AVERAGE POWER	24
7.5. POWER SPECTRAL DENSITY	25
7.6. CONDUCTED SPURIOUS EMISSIONS	29
8. RADIATED TEST RESULTS	36
8.1. LIMITS AND PROCEDURE	36
8.2. TRANSMITTER ABOVE 1 GHz	37
8.3. WORST-CASE BELOW 1 GHz	46
9. AC POWER LINE CONDUCTED EMISSIONS	49
10. SETUP PHOTOS	53

1. ATTESTATION OF TEST RESULTS

COMPANY NAME: APPLE, INC.
1 INFINITE LOOP
CUPERTINO, CA 95014, U.S.A.

EUT DESCRIPTION: The Apple iPad is a tablet device with iPod functions (music, application support, and video), 802.11a/b/g/n radio, and Bluetooth radio functions.

MODEL: A1432, A1454, & A1455

SERIAL NUMBER: 20558

DATE TESTED: AUGUST 16, 2012

APPLICABLE STANDARDS	
STANDARD	TEST RESULTS
CFR 47 Part 15 Subpart C	Pass
INDUSTRY CANADA RSS-210 Issue 8 Annex 8	Pass
INDUSTRY CANADA RSS-GEN Issue 3	Pass

UL CCS tested the above equipment in accordance with the requirements set forth in the above standards. All indications of Pass/Fail in this report are opinions expressed by UL CCS based on interpretations and/or observations of test results. Measurement Uncertainties were not taken into account and are published for informational purposes only. The test results show that the equipment tested is capable of demonstrating compliance with the requirements as documented in this report.

Note: The results documented in this report apply only to the tested sample, under the conditions and modes of operation as described herein. This document may not be altered or revised in any way unless done so by UL CCS and all revisions are duly noted in the revisions section. Any alteration of this document not carried out by UL CCS will constitute fraud and shall nullify the document. This report must not be used by the client to claim product certification, approval, or endorsement by NVLAP, NIST, any agency of the Federal Government, or any agency of any government.

Approved & Released For UL CCS By:

Tested By:



FRANK IBRAHIM
WISE PROJECT LEADER
UL CCS

TOM CHEN
EMC ENGINEER
UL CCS

2. TEST METHODOLOGY

The tests documented in this report were performed in accordance with ANSI C63.10-2003, FCC CFR 47 Part 2, FCC CFR 47 Part 15, RSS-GEN Issue 3, and RSS-210 Issue 8.

3. FACILITIES AND ACCREDITATION

The test sites and measurement facilities used to collect data are located at 47173 Benicia Street, Fremont, California, USA.

UL CCS is accredited by NVLAP, Laboratory Code 200065-0. The full scope of accreditation can be viewed at <http://www.ccsemc.com>.

4. CALIBRATION AND UNCERTAINTY

4.1. MEASURING INSTRUMENT CALIBRATION

The measuring equipment utilized to perform the tests documented in this report has been calibrated in accordance with the manufacturer's recommendations, and is traceable to recognized national standards.

4.2. SAMPLE CALCULATION

Where relevant, the following sample calculation is provided:

$$\begin{aligned} \text{Field Strength (dBuV/m)} &= \text{Measured Voltage (dBuV)} + \text{Antenna Factor (dB/m)} + \\ &\text{Cable Loss (dB)} - \text{Preamp Gain (dB)} \\ 36.5 \text{ dBuV} + 18.7 \text{ dB/m} + 0.6 \text{ dB} - 26.9 \text{ dB} &= 28.9 \text{ dBuV/m} \end{aligned}$$

4.3. MEASUREMENT UNCERTAINTY

Where relevant, the following measurement uncertainty levels have been estimated for tests performed on the apparatus:

PARAMETER	UNCERTAINTY
Conducted Disturbance, 0.15 to 30 MHz	3.52 dB
Radiated Disturbance, 30 to 1000 MHz	4.94 dB

Uncertainty figures are valid to a confidence level of 95%.

5. EQUIPMENT UNDER TEST

5.1. DESCRIPTION OF EUT

The EUT is a iPad tablet device with iPod functions (music, application support, and video), 802.11a/b/g/n radio, and Bluetooth radio functions.

5.2. DESCRIPTION OF MODELS DIFFERENCES

FCC ID: BCGA1432
IC ID: 579C-A1432
Model #: A1432

Model A1432, is a tablet with multimedia functions (music, application support, and video)IEEE 802.11a/b/g/n radio and Bluetooth radio. The rechargeable battery is not user accessible.

FCC ID: BCGA1454
IC ID: 579C-A1454
Model #: A1454

Model A1454 is a tablet with multimedia functions (music, application support, and video), cellular GSM/GPRS/EGPRS/WCDMA/HSPA+/DC-HSDPA/LTE radio, IEEE 802.11a/b/g/n and Bluetooth radio. The rechargeable battery is not user accessible.

FCC ID: BCGA1455
IC ID: 579C-A1455
Model #: A1455

Model A1455, is a tablet with multimedia functions (music, application support, and video), cellular GSM/GPRS/EGPRS/WCDMA/HSPA+/DC-HSDPA/CDMA1xRTT/ EV-DO Rev 0, A, B / LTE radio, IEEE 802.11a/b/g/n radio and Bluetooth radio. The rechargeable battery is not user accessible.

5.3. MAXIMUM OUTPUT POWER

The transmitter has a maximum peak conducted output power as follows:

Frequency Range (MHz)	Mode	Output Power (dBm)	Output Power (mW)
2402 - 2480	Bluetooth LE	8.34	6.82

5.4. DESCRIPTION OF AVAILABLE ANTENNAS

The radio utilizes a PIFA antenna, with a maximum gain as shown below:

<i>Frequency Band (GHz)</i>	<i>Antenna Gain (dBi)</i>
2.4-2.4835	1.41
5.15-5.25	4.70
5.25-5.35	5.08
5.5-5.7	5.42
5.725-5.85	5.27

5.5. SOFTWARE AND FIRMWARE

The firmware installed in the EUT during testing was 10A378

The EUT driver software installed during testing was Broadcom_Rel_6_10_56_166

The EUT is also linked in Bluetooth Enable Test mode with Rohde & Schwarz CBT Test box.

5.6. WORST-CASE CONFIGURATION AND MODE

For Radiated Emissions below 1 GHz and Power line Conducted Emissions, the channel with the highest conducted output power was selected as a worst-case scenario.

For the fundamental investigation, since the EUT is a portable device that has three orientations; X, Y and Z orientations have been investigated, also with AC/DC adapter, and earphone, and the worst case was found to be at X orientation without AC adapter and earphone.

For 2.4 GHz band, an investigation of the fundamental frequency on both Ant0 and Ant1 ports showed that Ant0 is worst-case; therefore, all final radiated testing was performed using Ant0.

For 5 GHz bands, an investigation of the fundamental frequency on both Ant0 and Ant1 ports showed that Ant1 is worst-case; therefore, all final radiated testing was performed using Ant1.

5.7. DESCRIPTION OF TEST SETUP

SUPPORT EQUIPMENT

Support Equipment List			
Description	Manufacturer	Model	Serial Number
AC Adapter	Apple	A1344	NA
Laptop PC	Apple	MacBook Pro	NA
Directional Coupler	RF-Lambda	RFDC5M06G15	NA
Headset	Apple	NA	NA

I/O CABLES (Conducted Setup)

I/O CABLE LIST						
Cable No.	Port	# of Identical Ports	Connector Type	Cable Type	Cable Length	Remarks
1	In/Out	1	SMA	Shielded	0.2m	NA
2	In/Out	1	SMA	Shielded	0.6m	NA
3	Antenna Port	1	SMA	Shielded	0.1m	NA
4	Laptop	1	USB	Un-shielded	1m	NA

I/O CABLES (Radiated Setup)

I/O CABLE LIST						
Cable No.	Port	# of Identical Ports	Connector Type	Cable Type	Cable Length	Remarks
1	AC	1	US115VAC	Un-Shielded	2m	NA
2	DC	1	DC	Un-Shielded	1m	NA
3	Jack	1	Earphone	Shielded	0.5m	NA
4	Antenna Port	1	Horn	Un-shielded	2m	NA

SETUP DIAGRAM FOR CONDUCTED TESTS

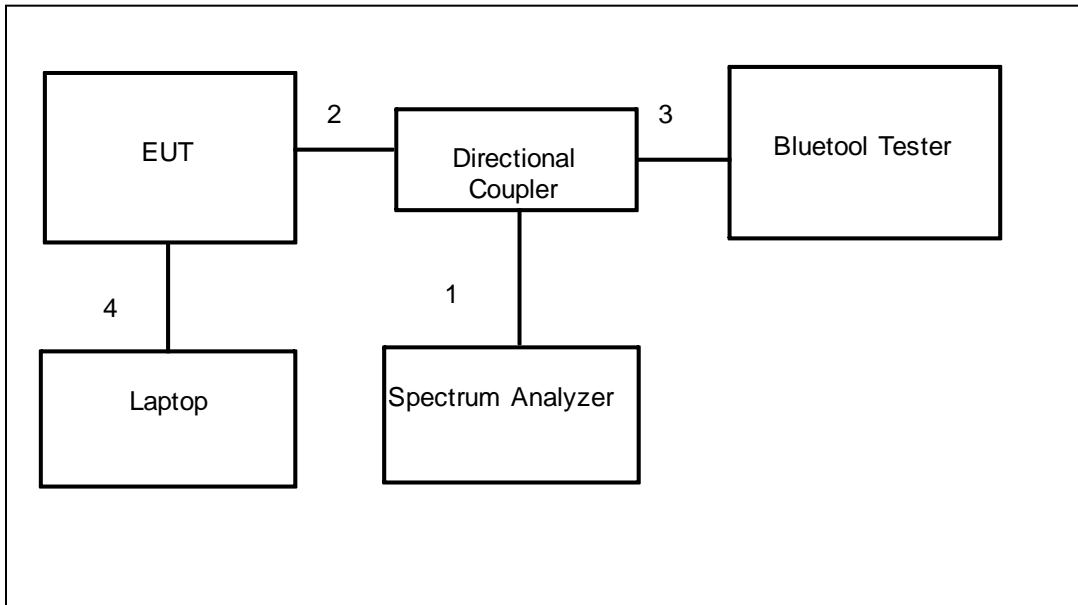

SETUP DIAGRAM FOR CONDUCTED TESTS

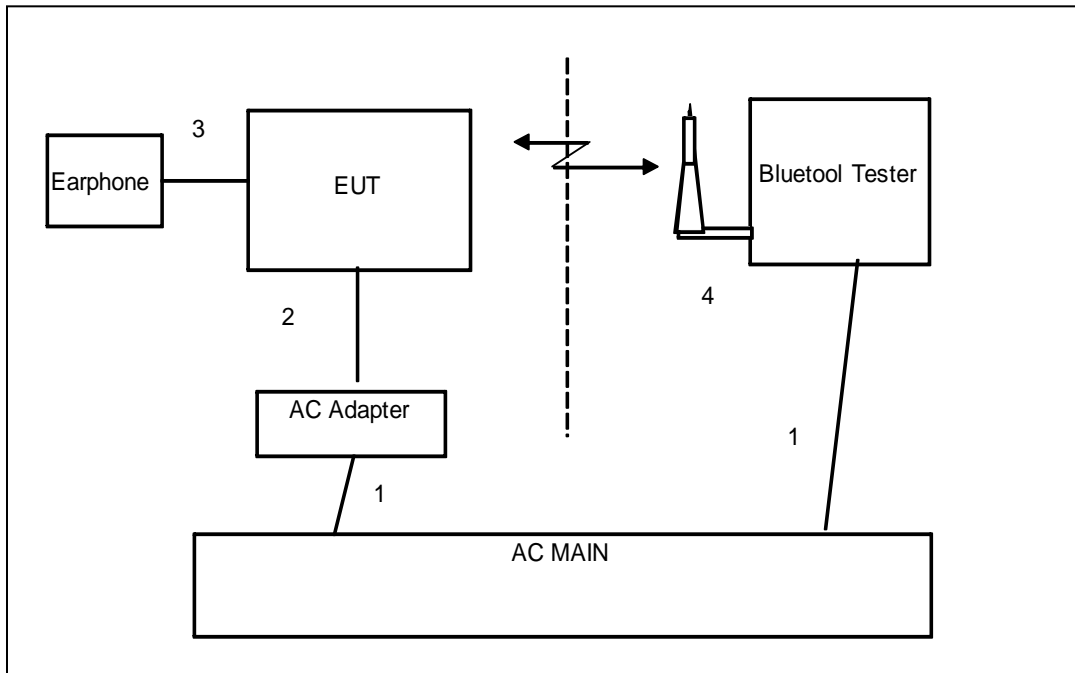

6. TEST AND MEASUREMENT EQUIPMENT

The following test and measurement equipment was utilized for the tests documented in this report:

TEST EQUIPMENT LIST				
Description	Manufacturer	Model	Asset	Cal Due
Preamplifier, 26.5 GHz	Agilent / HP	8449B	C01052	07/14/13
Antenna, Horn, 18 GHz	EMCO	3115	C00945	06/29/13
Preamplifier, 1300 MHz	Agilent / HP	8447D	C00580	11/11/12
Antenna, Bilog, 2 GHz	Sunol Sciences	JB1	C01016	07/12/13
Horn Antenna, 26.5 GHz	ARA	MWH-1826/B	C00589	07/28/13
Horn Antenna, 40 GHz	ARA	MWH-2640/B	C00981	05/10/13
Preamplifier, 40 GHz	Miteq	NSP4000-SP2	C00990	03/14/13
Reject Filter, 2.0-2.9 GHz	Micro-Tronics	BRM50702	N02684	CNR
High Pass Filter, 7.6 GHz	Micro-Tronics	HPM13195	N02682	CNR
Spectrum Analyzer, 44 GHz	Agilent / HP	E4446A	C01159	04/09/13
CBT Bluetooth tester	Rohde Schwarz	CBT	10090	05/15/2013
Reject Filter, 5.725-5.825 GHz	Micro-Tronics	BRC13192	N02676	CNR
Reject Filter, 2.4-2.5 GHz	Micro-Tronics	BRM50702	N02685	CNR
Highpass Filter, 7.6 GHz	Micro-Tronics	HPM13195	N02682	CNR
EMI Test Receiver, 30MHz	R & S	ESHS 20	N02396	08/19/13
LISN, 30 MHz	FCC	LISN-50/250-25-2	N02625	12/13/12

7. ANTENNA PORT TEST RESULTS

7.1. 6 dB BANDWIDTH

LIMITS

FCC §15.247 (a) (2)

IC RSS-210 A8.2 (a)

The minimum 6 dB bandwidth shall be at least 500 kHz.

TEST PROCEDURE

KDB 558074 D01 v01 "Guidance for Performing Compliance Measurements on Digital Transmission Systems (DTS) Operating Under 15.247".

RESULTS

Channel	Frequency (MHz)	6 dB Bandwidth (MHz)	Minimum Limit (MHz)
Low	2402	0.6830	0.5
Middle	2440	0.6420	0.5
High	2480	0.6670	0.5

6 dB BANDWIDTH

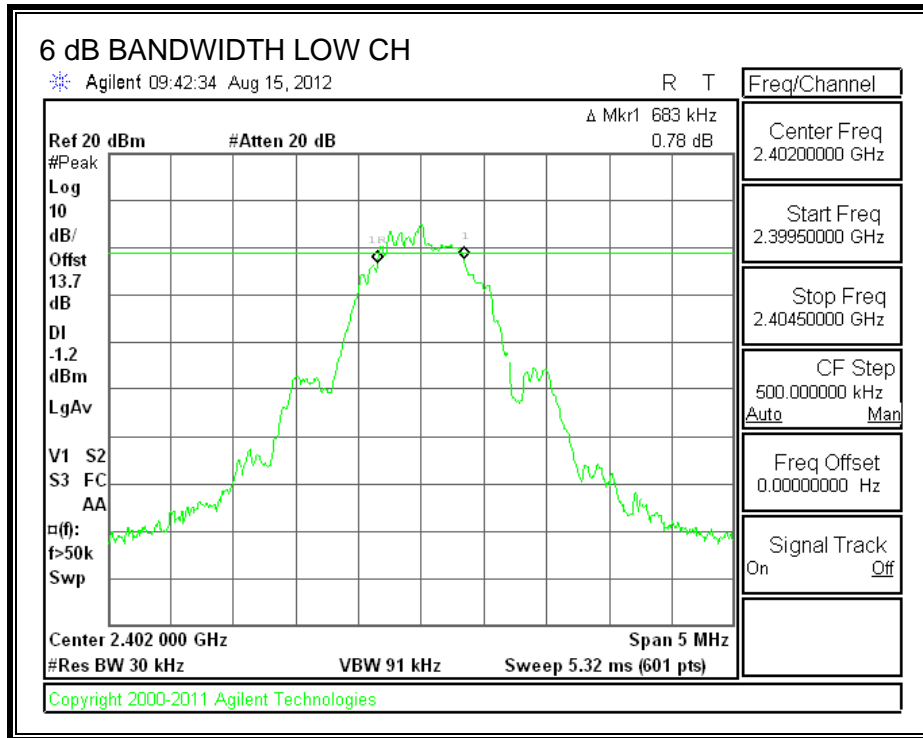

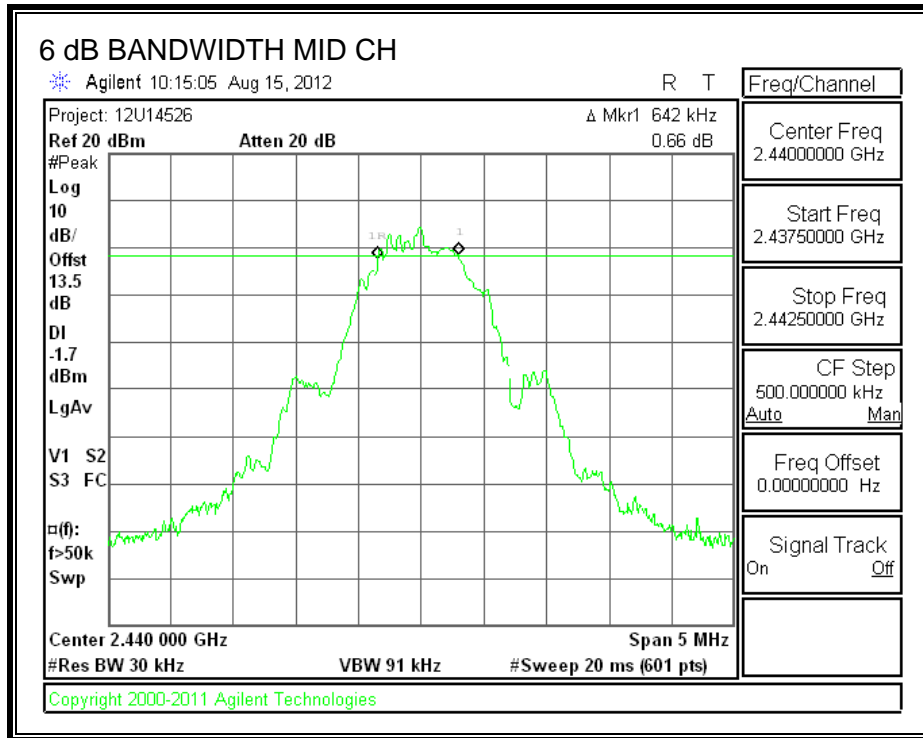

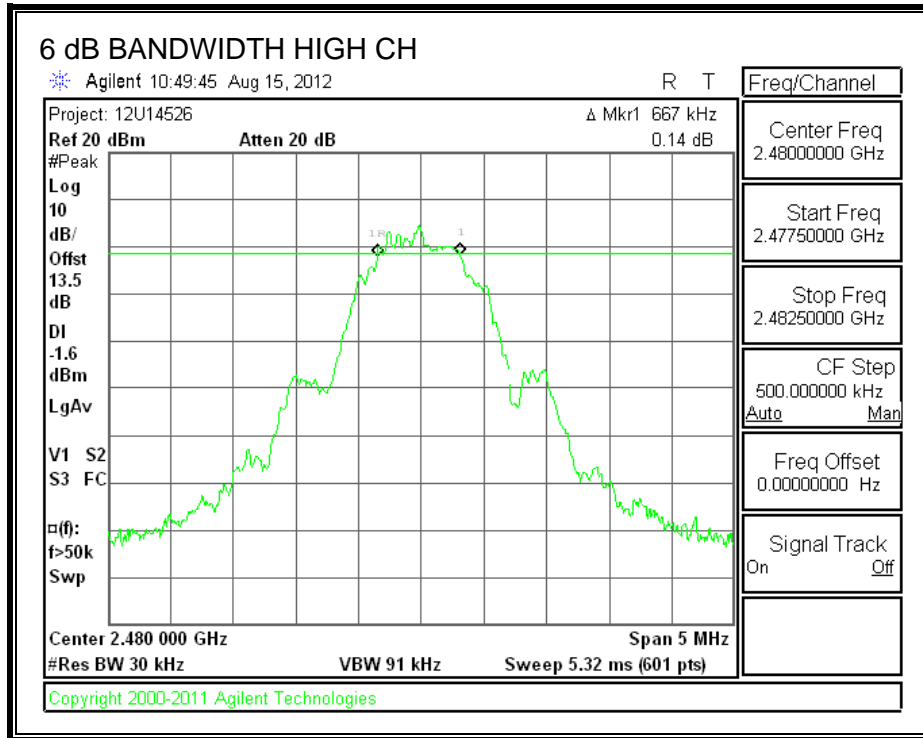

7.2. 99% BANDWIDTH

LIMITS

None; for reporting purposes only.

TEST PROCEDURE

The transmitter output is connected to the spectrum analyzer. The RBW is set to 1% to 3% of the 99 % bandwidth and to 1% of the span. The VBW is set to 3 times the RBW. The sweep time is coupled. The spectrum analyzer internal 99% bandwidth function is utilized.

RESULTS

Channel	Frequency (MHz)	99% Bandwidth (MHz)
Low	2402	1.0563
Middle	2440	1.0337
High	2480	1.0491

99% BANDWIDTH

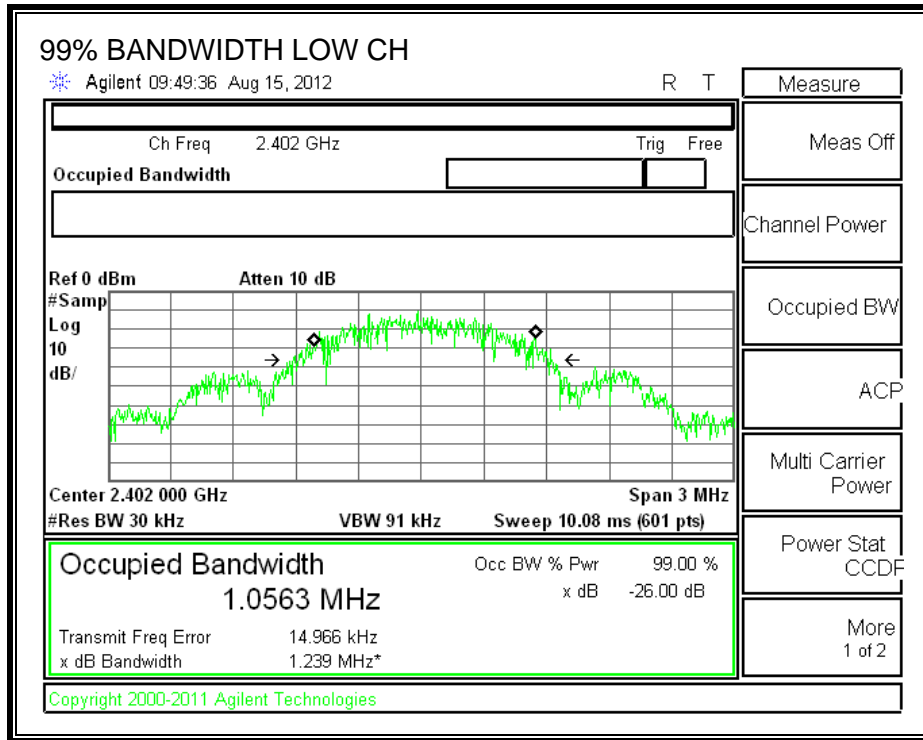

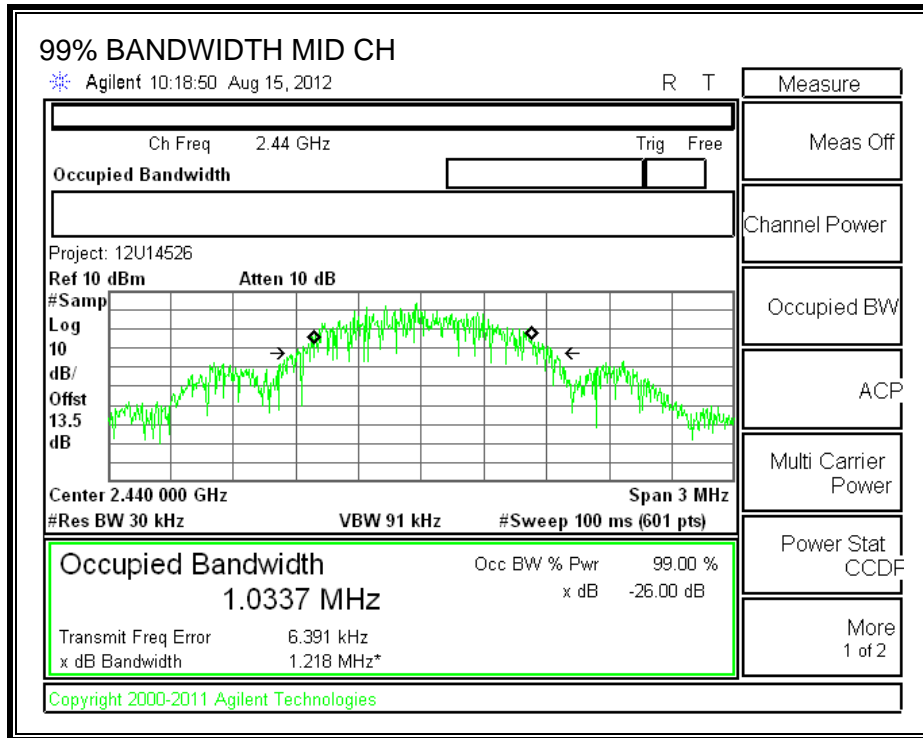

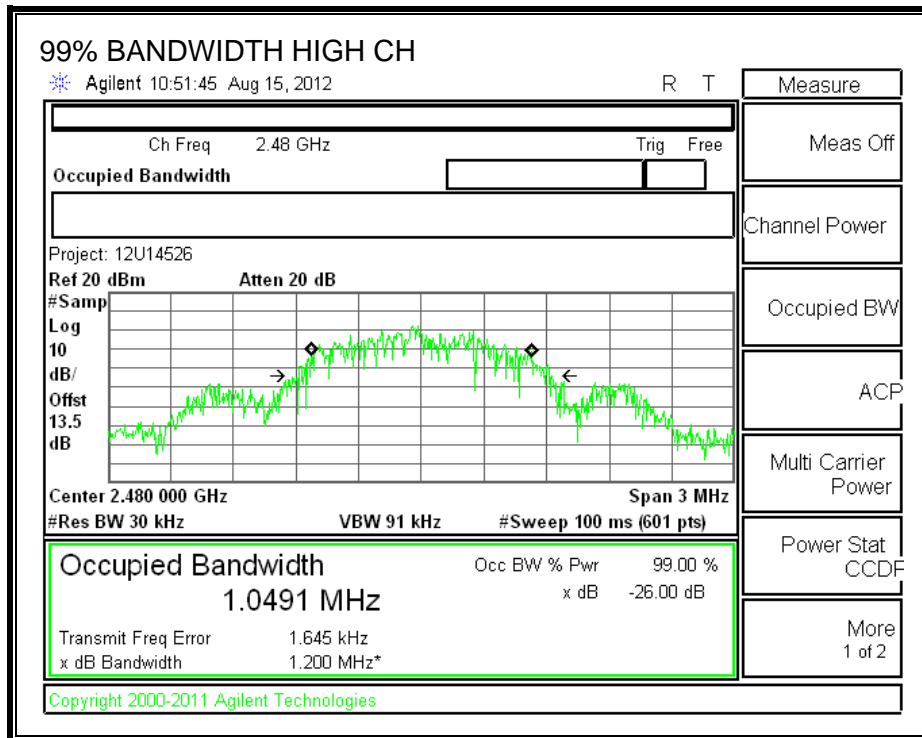

7.3. OUTPUT POWER

LIMITS

FCC §15.247 (b)

IC RSS-210 A8.4

The maximum antenna gain is less than or equal to 6 dBi, therefore the limit is 30 dBm.

TEST PROCEDURE

KDB 558074 D01 v01 "Guidance for Performing Compliance Measurements on Digital Transmission Systems (DTS) Operating Under 15.247".

RESULTS

Channel	Frequency (MHz)	Peak Power Reading (dBm)	Limit (dBm)	Margin (dB)
Low	2402	8.34	30	-21.66
Middle	2440	8.09	30	-21.91
High	2480	8.20	30	-21.80

OUTPUT POWER

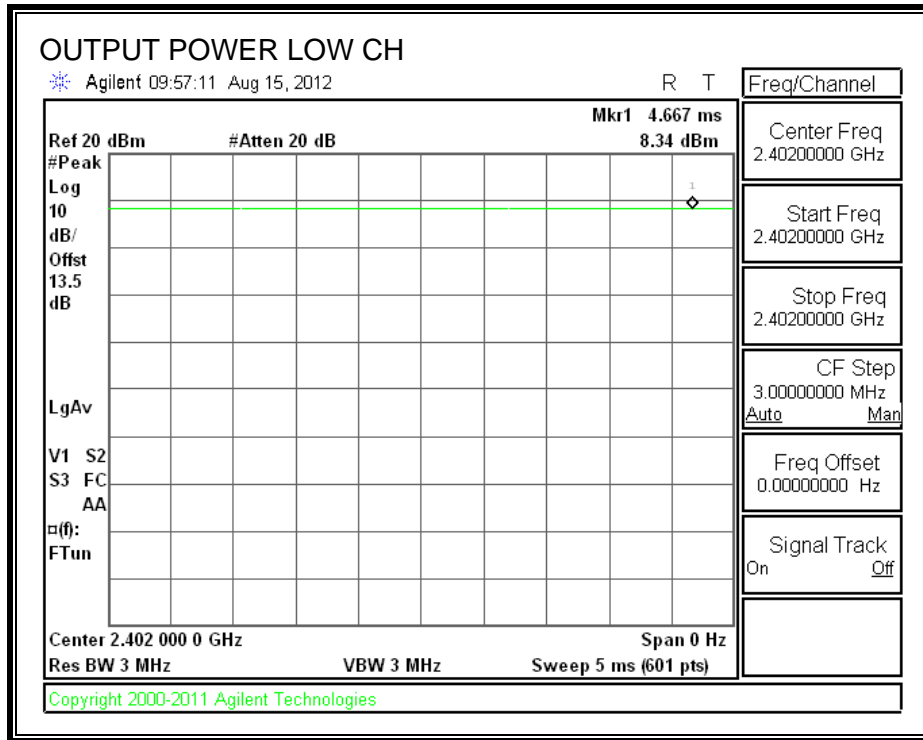

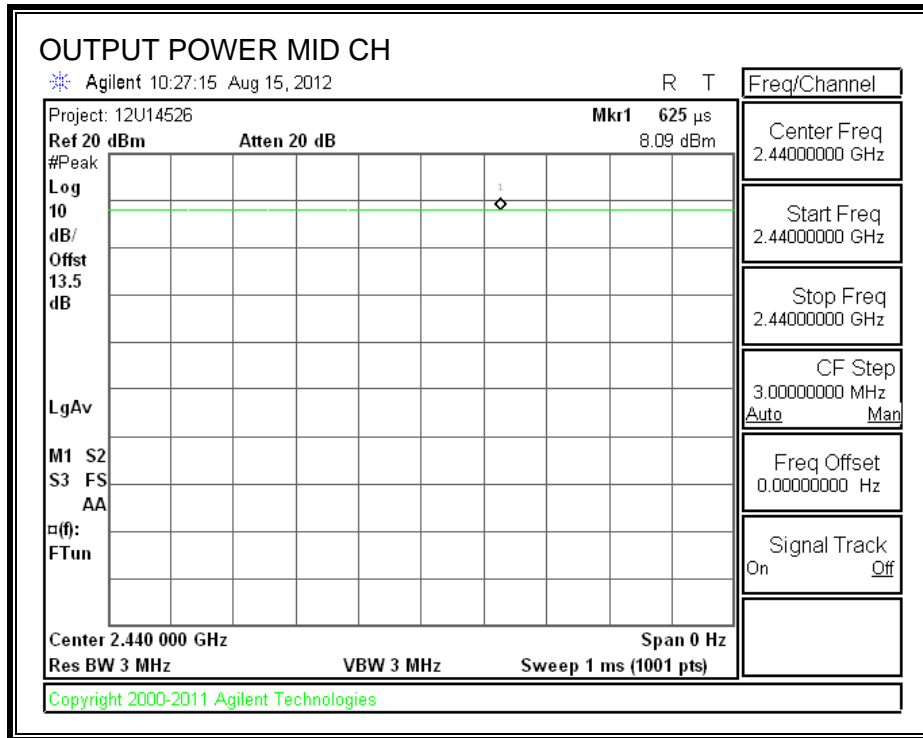

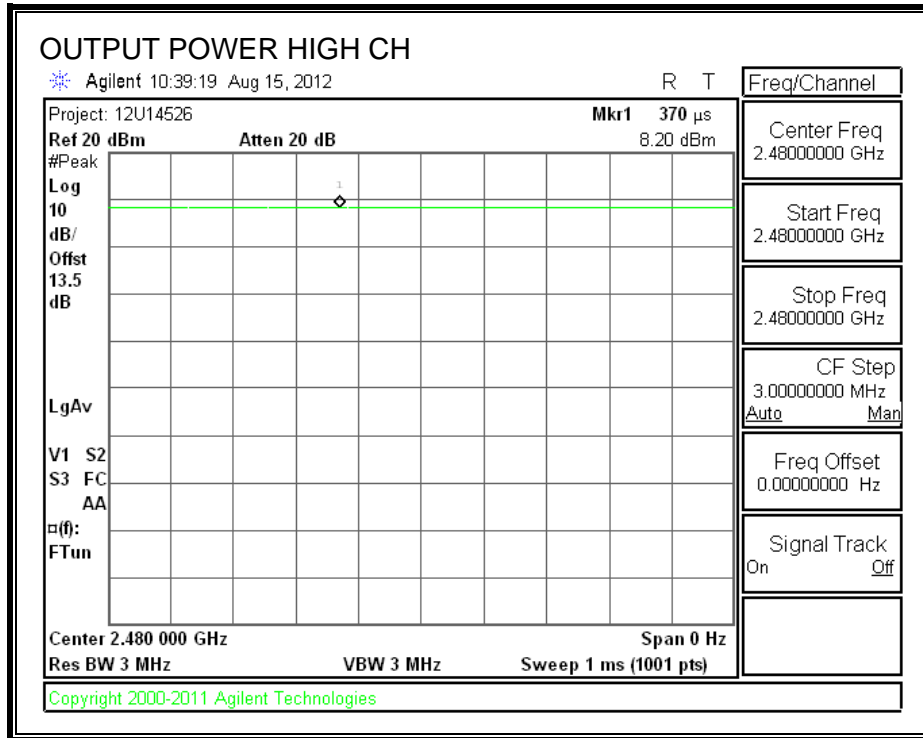

7.4. AVERAGE POWER

LIMITS

None; for reporting purposes only.

TEST PROCEDURE

The transmitter output is connected to a Bluetooth Tester

RESULTS

The cable assembly insertion loss of 11 dB (including 10 dB pad and 1 dB cable) was entered as an offset in the power meter to allow for direct reading of power.

Channel	Frequency (MHz)	AV power (dBm)
Low	2402	7.90
Middle	2440	7.80
High	2480	7.90

7.5. POWER SPECTRAL DENSITY

LIMITS

FCC §15.247 (e)

IC RSS-210 A8.2 (b)

TEST PROCEDURE

KDB 558074 D01 v01 "Guidance for Performing Compliance Measurements on Digital Transmission Systems (DTS) Operating Under 15.247".

RESULTS

Channel	Frequency (MHz)	PSD (dBm)	10log(3kHz/100kHz) (dBm)	Limit (dBm)	Margin (dB)
Low	2402	7.16	-15.2	8	-16.04
Middle	2440	6.94	-15.2	8	-16.26
High	2480	7.00	-15.2	8	-16.20

POWER SPECTRAL DENSITY

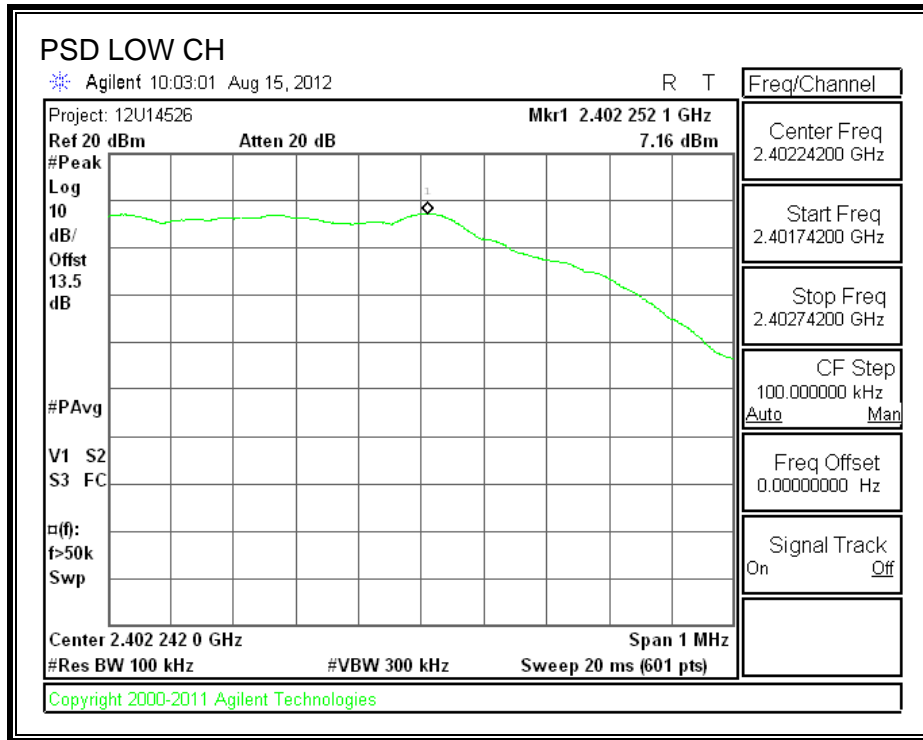

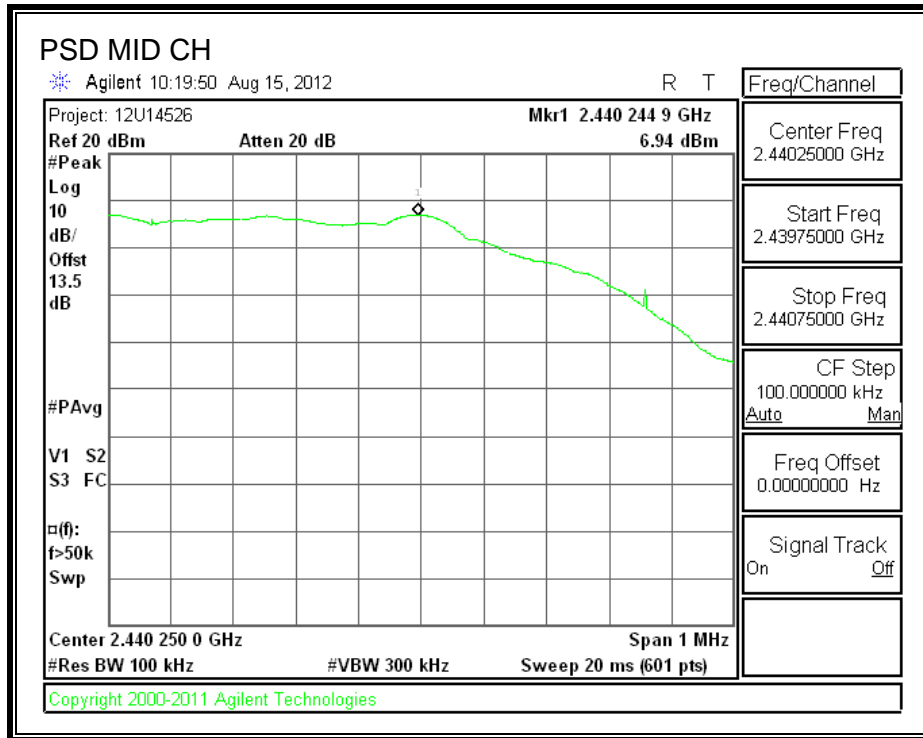

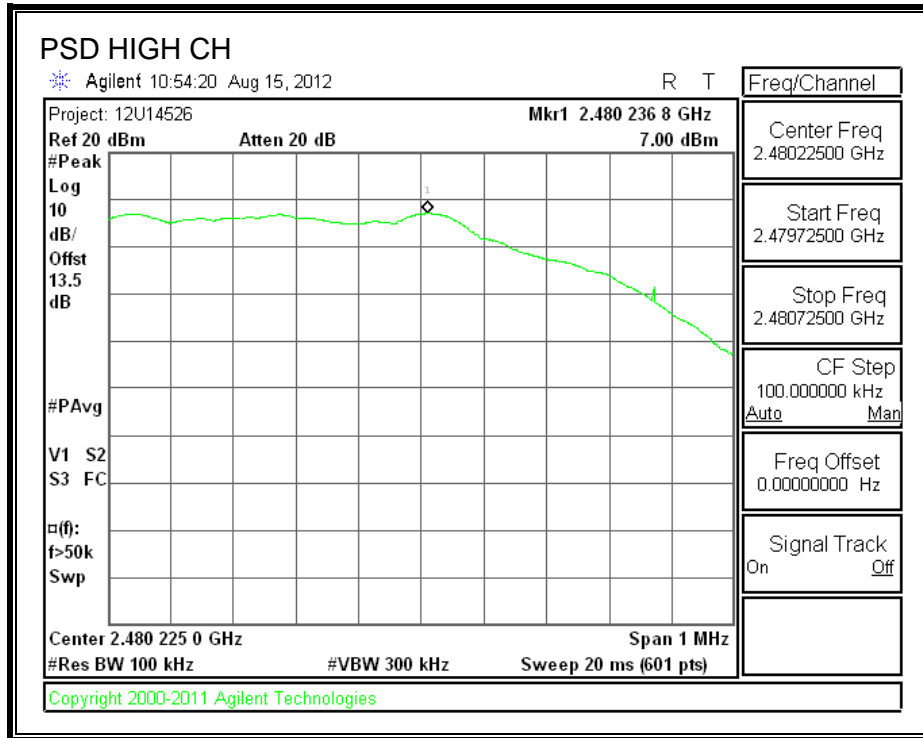

7.6. CONDUCTED SPURIOUS EMISSIONS

LIMITS

FCC §15.247 (d)

IC RSS-210 A8.5

Output power was measured based on the use of a peak measurement, therefore the required attenuation is 20 dB.

TEST PROCEDURE

KDB 558074 D01 v01 "Guidance for Performing Compliance Measurements on Digital Transmission Systems (DTS) Operating Under 15.247".

RESULTS

SPURIOUS EMISSIONS, LOW CHANNEL

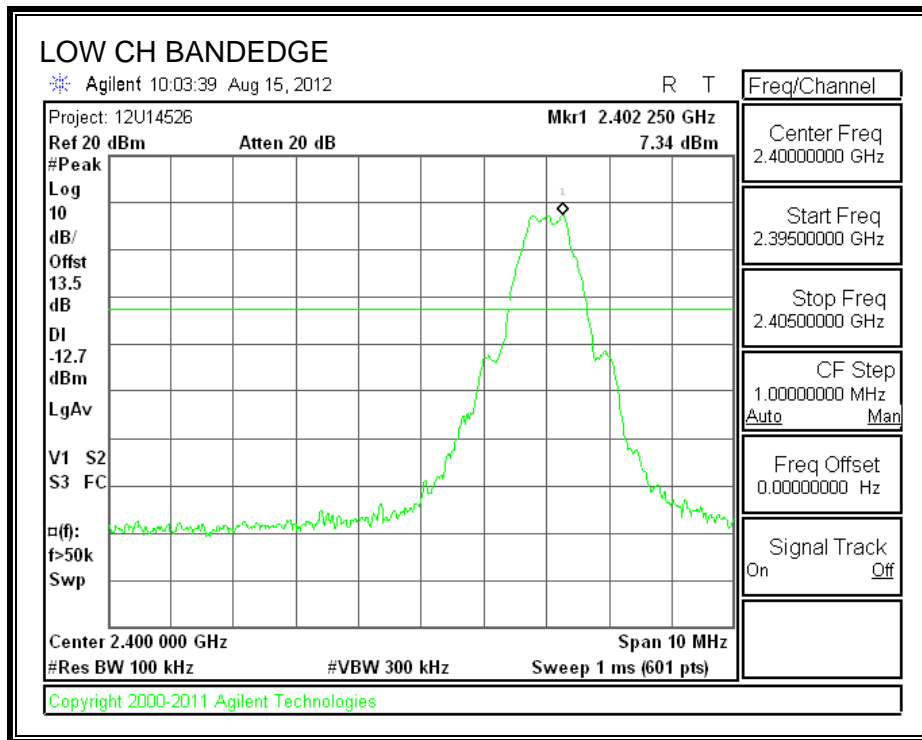

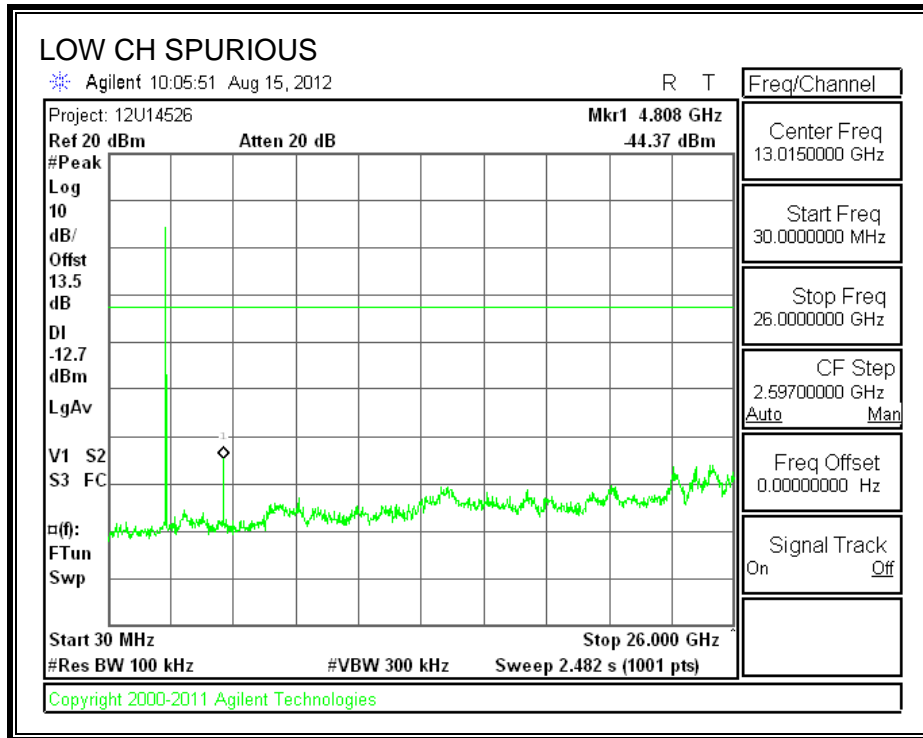

SPURIOUS EMISSIONS, MID CHANNEL

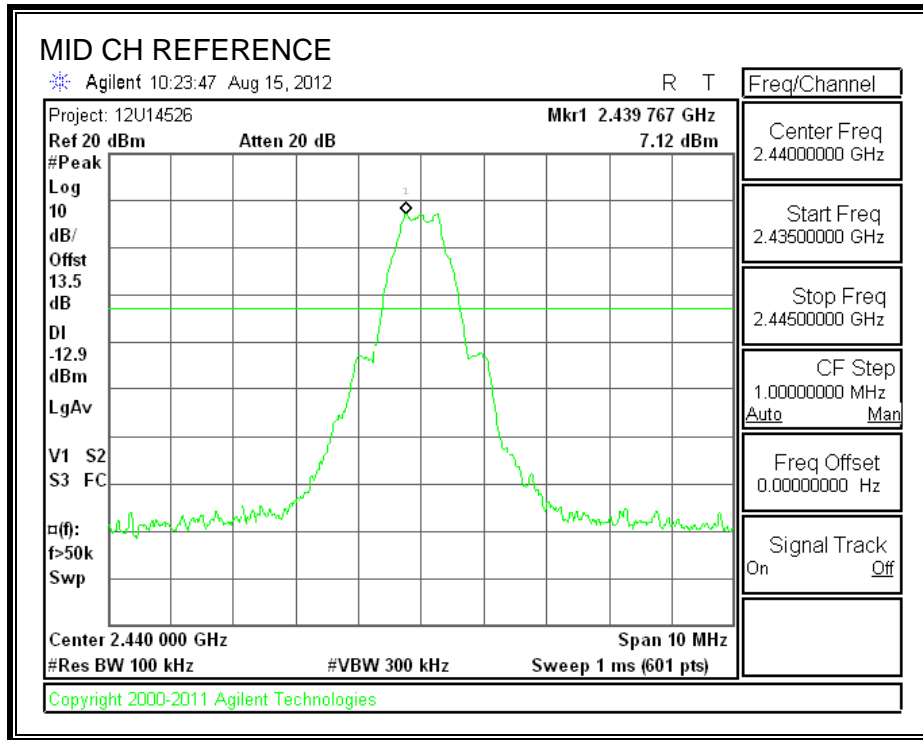

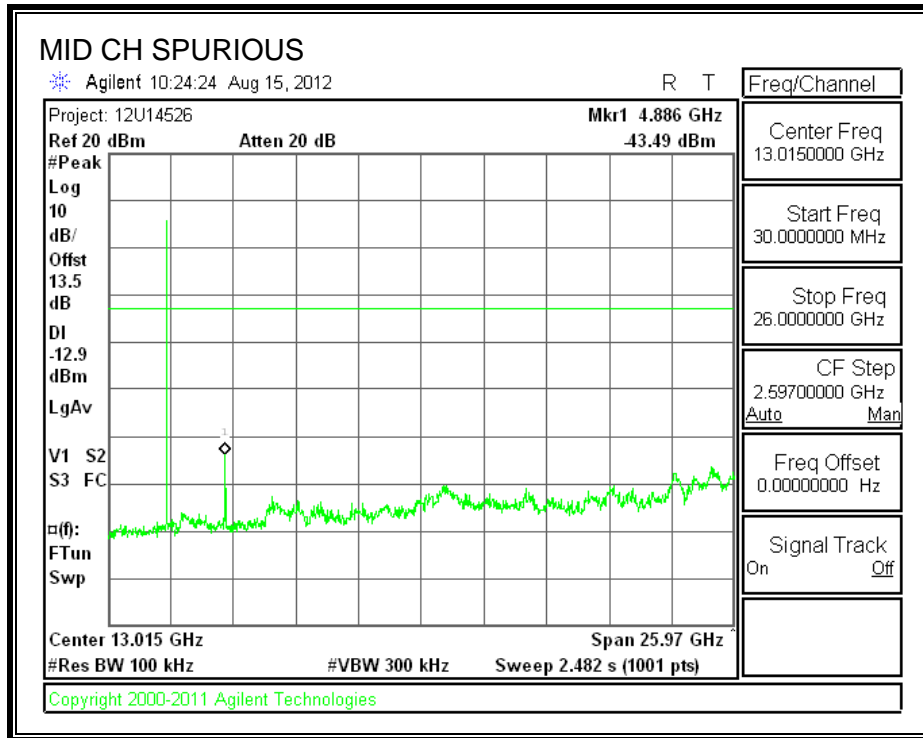

SPURIOUS EMISSIONS, HIGH CHANNEL

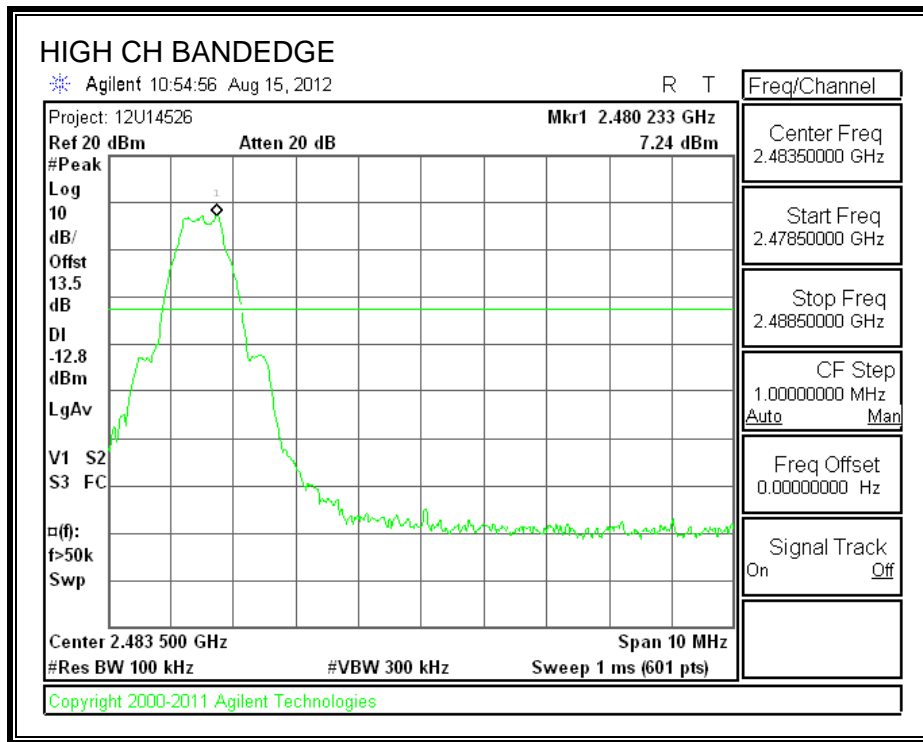

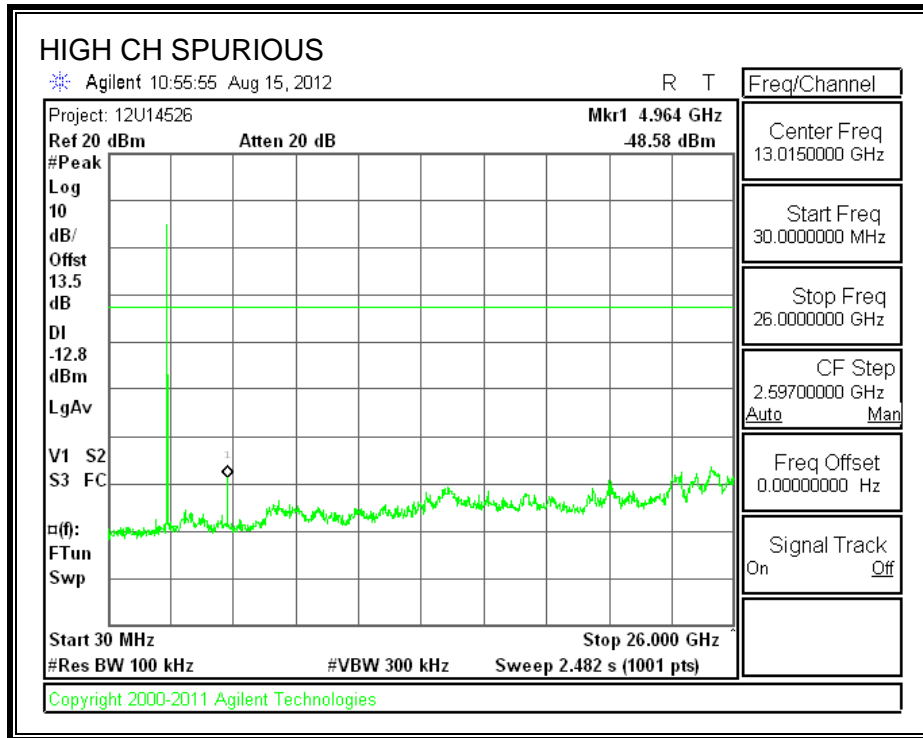

8. RADIATED TEST RESULTS

8.1. LIMITS AND PROCEDURE

LIMITS

FCC §15.205 and §15.209

IC RSS-210 Clause 2.6 (Transmitter)

IC RSS-GEN Clause 6 (Receiver)

Frequency Range (MHz)	Field Strength Limit (uV/m) at 3 m	Field Strength Limit (dBuV/m) at 3 m
30 - 88	100	40
88 - 216	150	43.5
216 - 960	200	46
Above 960	500	54

TEST PROCEDURE

The EUT is placed on a non-conducting table 80 cm above the ground plane. The antenna to EUT distance is 3 meters. The EUT is configured in accordance with ANSI C63.4. The EUT is set to transmit in a continuous mode.

For measurements below 1 GHz the resolution bandwidth is set to 100 kHz for peak detection measurements or 120 kHz for quasi-peak detection measurements. Peak detection is used unless otherwise noted as quasi-peak.

For measurements above 1 GHz the resolution bandwidth is set to 1 MHz, then the video bandwidth is set to 1 MHz for peak measurements and 10 Hz for average measurements.

The spectrum from 30 MHz to 26 GHz is investigated with the transmitter set to the lowest, middle, and highest channels in the 2.4 GHz band.

The spectrum from 30 MHz to 40 GHz is investigated with the transmitter set to the lowest, middle, and highest channels in each applicable band.

The frequency range of interest is monitored at a fixed antenna height and EUT azimuth. The EUT is rotated through 360 degrees to maximize emissions received. The antenna is scanned from 1 to 4 meters above the ground plane to further maximize the emission. Measurements are made with the antenna polarized in both the vertical and the horizontal positions.

8.2. TRANSMITTER ABOVE 1 GHz

RESTRICTED BANDEDGE (LOW CHANNEL, HORIZONTAL)

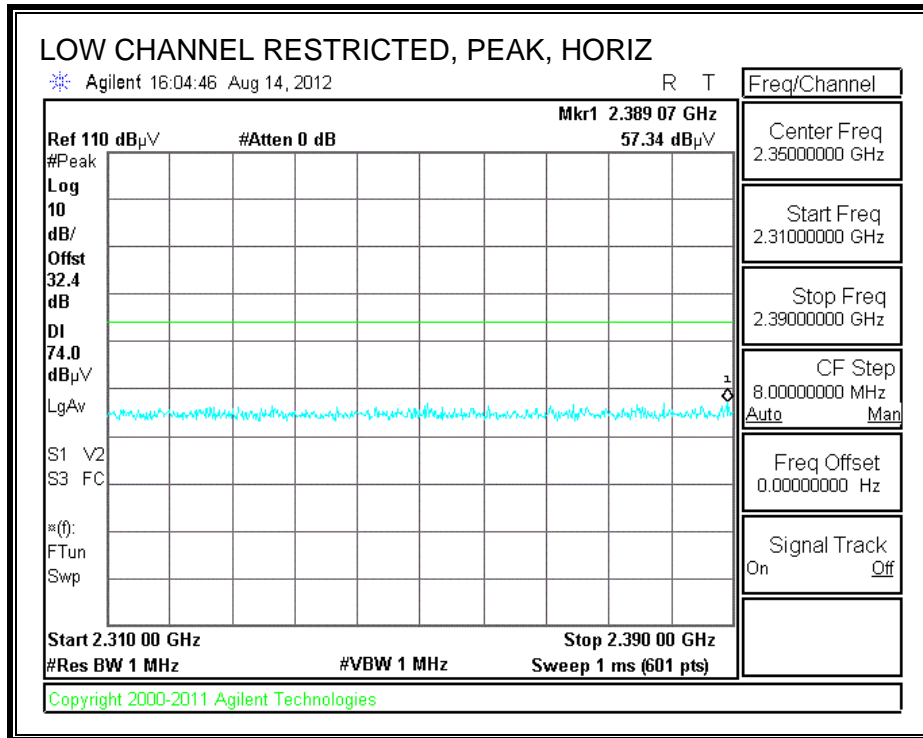

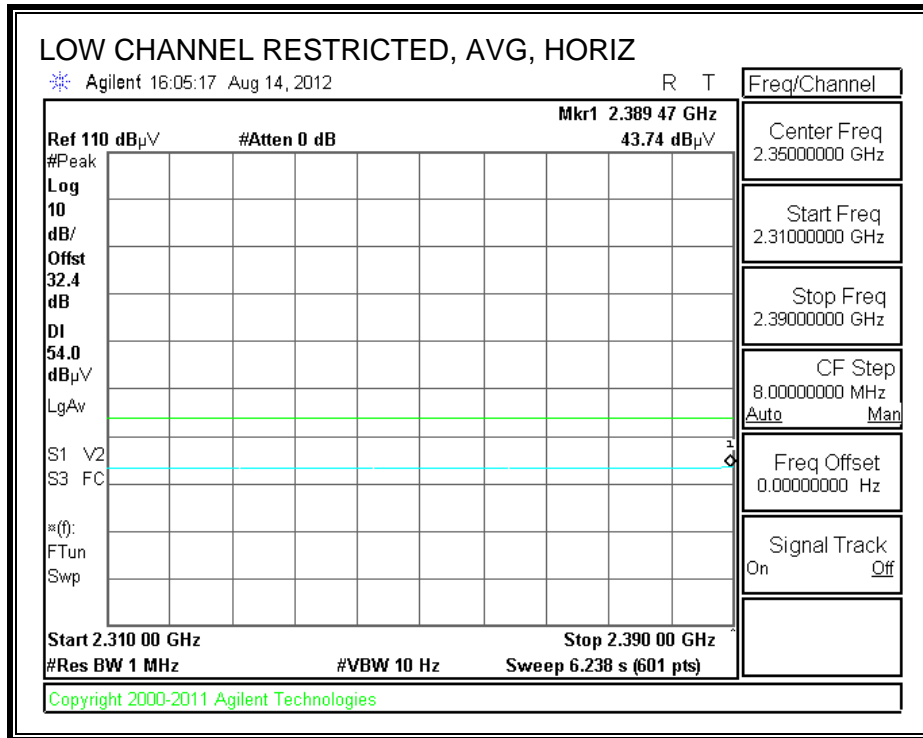

RESTRICTED BANDEDGE (LOW CHANNEL, VERTICAL)

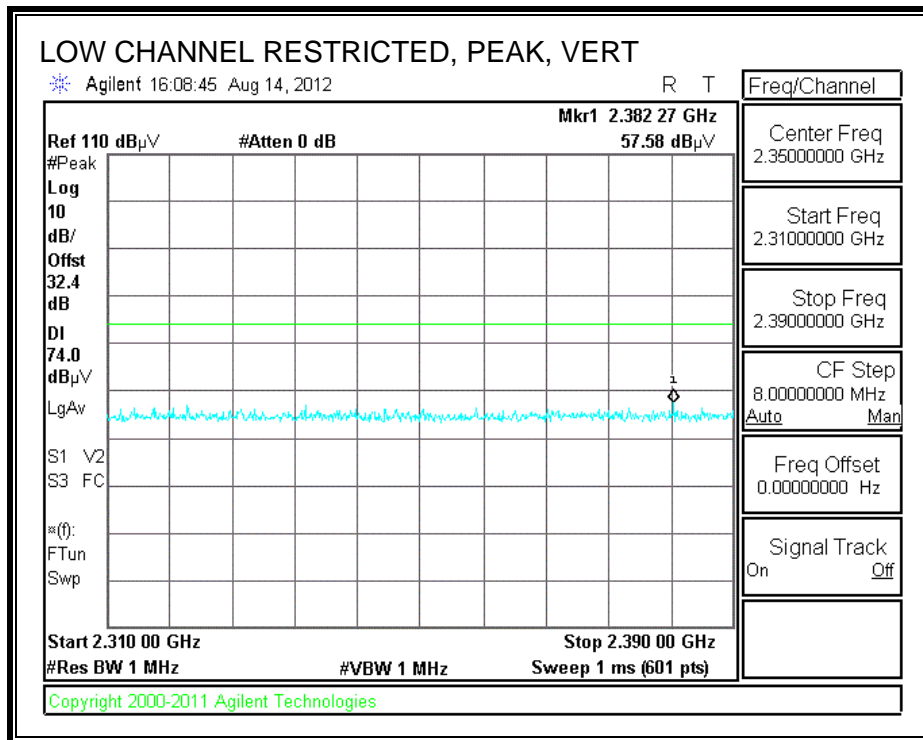

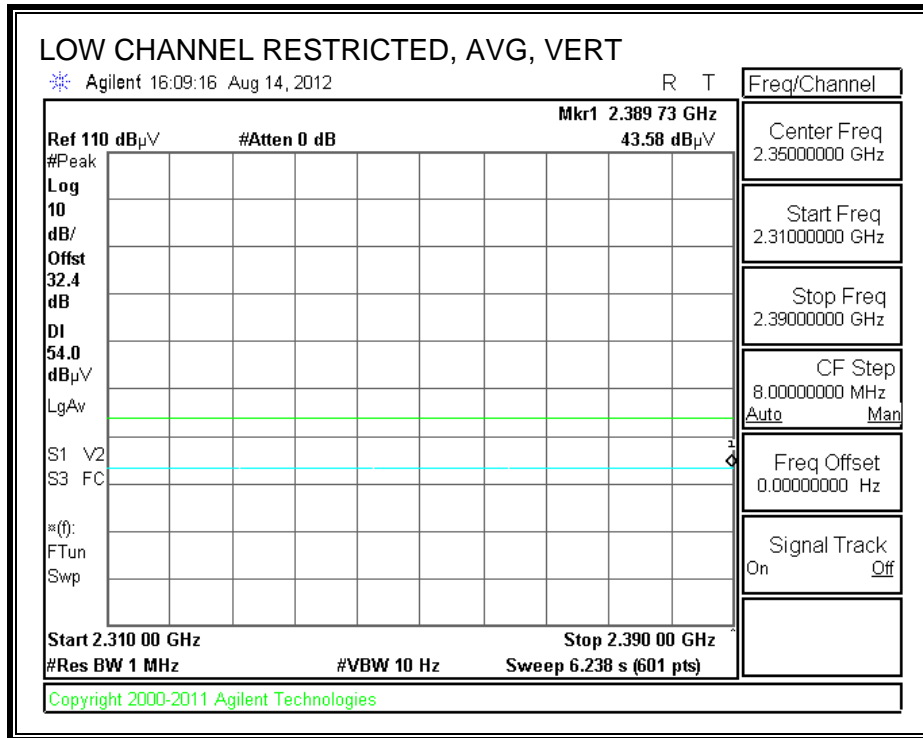

RESTRICTED BANDEDGE (HIGH CHANNEL, HORIZONTAL)

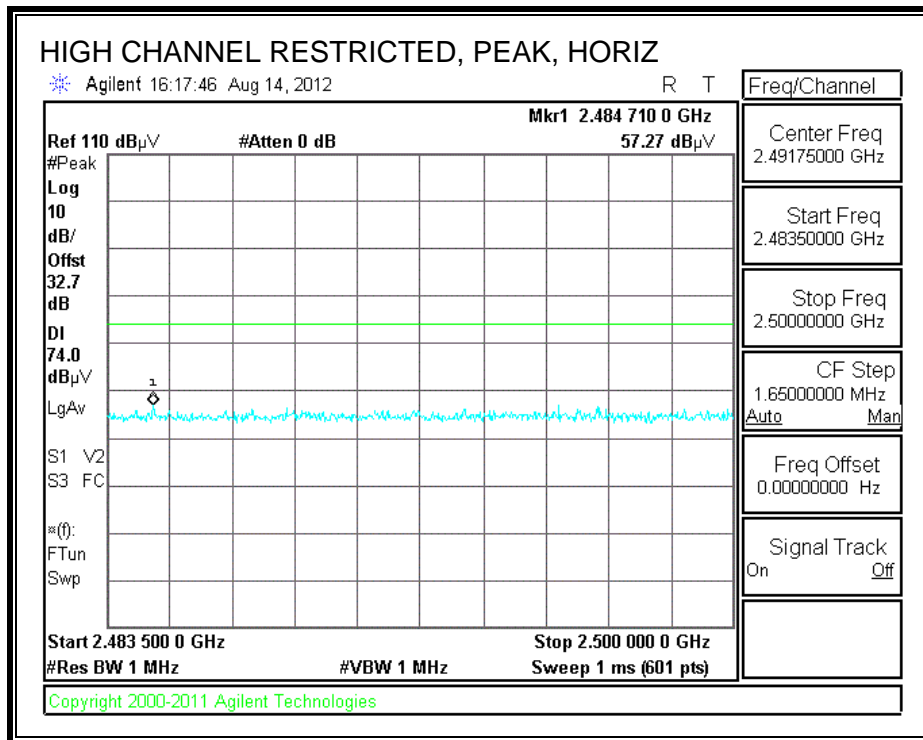

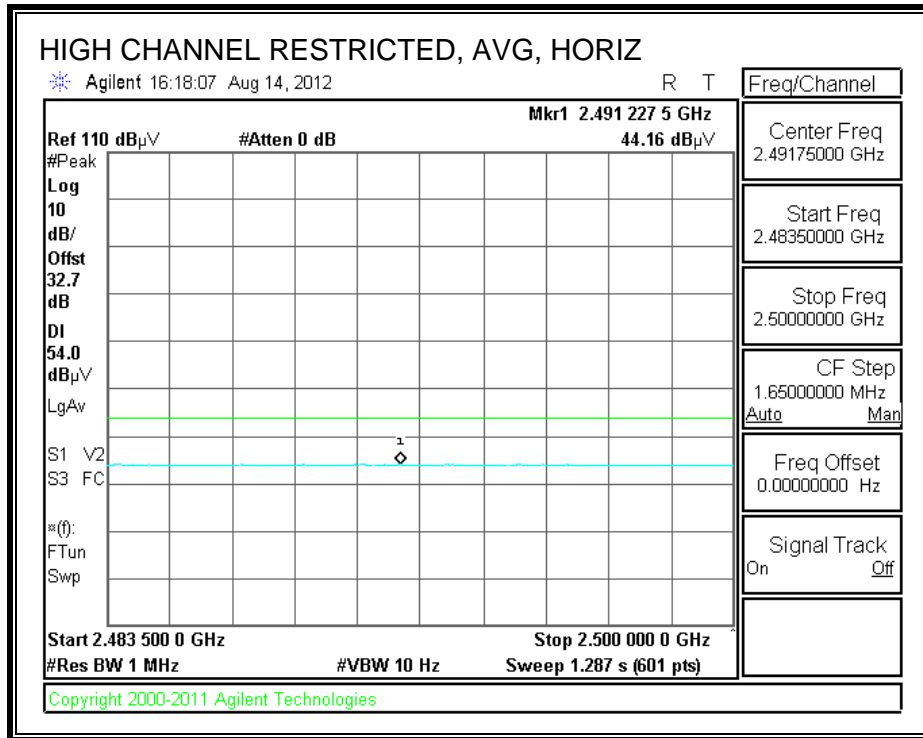

RESTRICTED BANDEDGE (HIGH CHANNEL, VERTICAL)

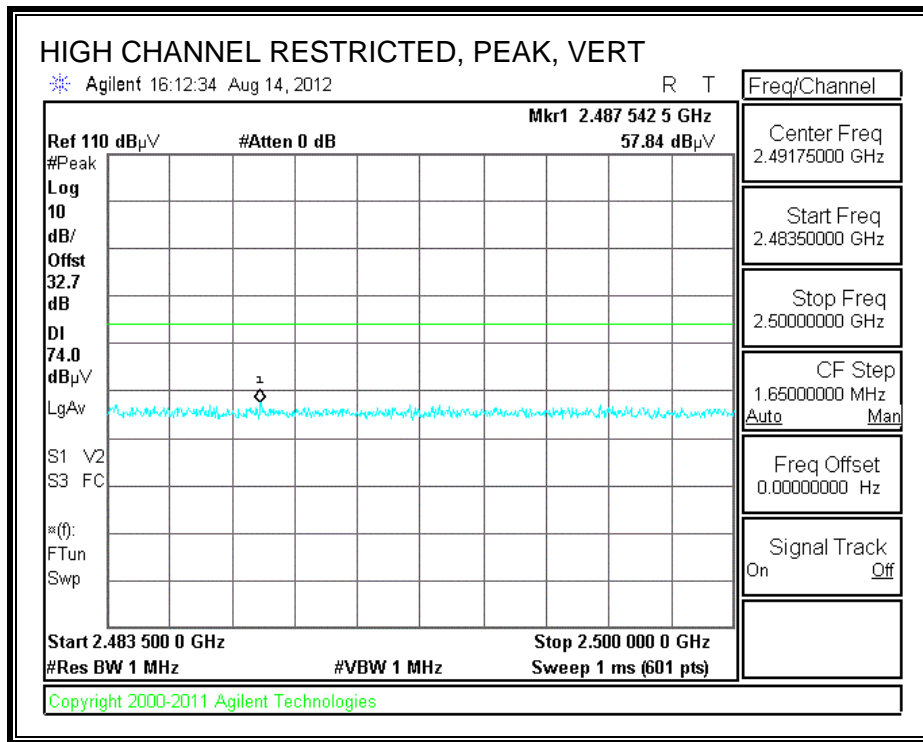

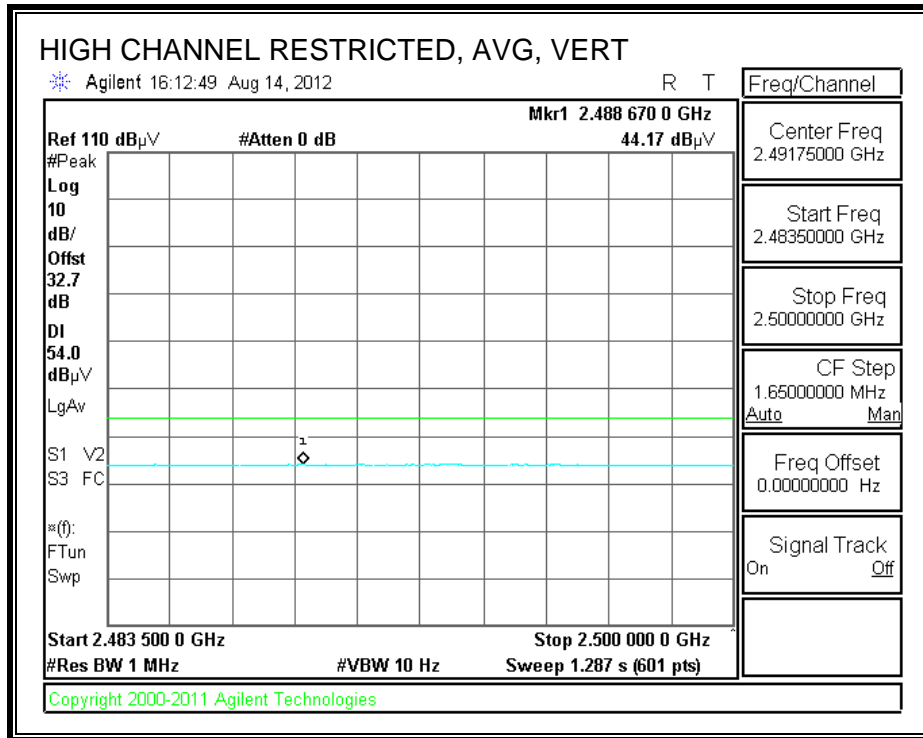

HARMONICS AND SPURIOUS EMISSIONS

**High Frequency Measurement
 Compliance Certification Services, Fremont 5m Chamber**

Test Engr: Chin Pang
 Date: 08/14/12
 Project #: 12U14526
 Company: Apple
 Test Target: FCC 15.247
 Mode Oper: TX, BLE

f Measurement Frequency Amp Preamp Gain Average Field Strength Limit
 Dist Distance to Antenna D Corr Distance Correct to 3 meters Peak Field Strength Limit
 Read Analyzer Reading Avg Average Field Strength @ 3 m Margin vs. Average Limit
 AF Antenna Factor Peak Calculated Peak Field Strength Margin vs. Peak Limit
 CL Cable Loss HPF High Pass Filter

f GHz	Dist (m)	Read dBuV	AF dB/m	CL dB	Amp dB	D Corr dB	Fltr dB	Corr. dB	Limit dBuV/m	Margin dB	Ant. Pol. V/H	Det. P/A/QP	Notes
Low Ch, 2402MHz													
4.804	3.0	38.1	33.4	6.3	-35.5	0.0	0.0	42.2	74.0	-31.8	V	P	
4.804	3.0	25.4	33.4	6.3	-35.5	0.0	0.0	29.6	54.0	-24.4	V	A	
4.804	3.0	38.0	33.4	6.3	-35.5	0.0	0.0	42.1	74.0	-31.9	H	P	
4.804	3.0	25.4	33.4	6.3	-35.5	0.0	0.0	29.6	54.0	-24.4	H	A	
Mid Ch, 2440MHz													
4.880	3.0	37.3	33.5	6.3	-35.5	0.0	0.0	41.6	74.0	-32.4	V	P	
4.880	3.0	25.0	33.5	6.3	-35.5	0.0	0.0	29.3	54.0	-24.7	V	A	
7.320	3.0	36.6	35.7	8.5	-35.4	0.0	0.0	45.4	74.0	-28.6	V	P	
7.320	3.0	24.0	35.7	8.5	-35.4	0.0	0.0	32.8	54.0	-21.2	V	A	
4.880	3.0	38.1	33.5	6.3	-35.5	0.0	0.0	42.4	74.0	-31.6	H	P	
4.880	3.0	25.0	33.5	6.3	-35.5	0.0	0.0	29.3	54.0	-24.7	H	A	
7.320	3.0	36.8	35.7	8.5	-35.4	0.0	0.0	45.6	74.0	-28.4	H	P	
7.320	3.0	24.0	35.7	8.5	-35.4	0.0	0.0	32.9	54.0	-21.2	H	A	
High Ch, 2480MHz													
4.960	3.0	36.9	33.6	6.4	-35.5	0.0	0.0	41.3	74.0	-32.7	V	P	
4.960	3.0	24.5	33.6	6.4	-35.5	0.0	0.0	29.0	54.0	-25.0	V	A	
7.440	3.0	36.1	35.9	8.5	-35.5	0.0	0.0	45.1	74.0	-28.9	V	P	
7.440	3.0	23.6	35.9	8.5	-35.5	0.0	0.0	32.6	54.0	-21.4	V	A	
4.960	3.0	36.8	33.6	6.4	-35.5	0.0	0.0	41.2	74.0	-32.8	H	P	
4.960	3.0	24.6	33.6	6.4	-35.5	0.0	0.0	29.0	54.0	-25.0	H	A	
7.440	3.0	37.7	35.9	8.5	-35.5	0.0	0.0	46.8	74.0	-27.2	H	P	
7.440	3.0	23.6	35.9	8.5	-35.5	0.0	0.0	32.6	54.0	-21.4	H	A	

Rev. 4.1.2.7

Note: No other emissions were detected above the system noise floor.

8.3. WORST-CASE BELOW 1 GHz

SPURIOUS EMISSIONS 30 TO 1000 MHz (WORST-CASE CONFIGURATION, HORIZONTAL)

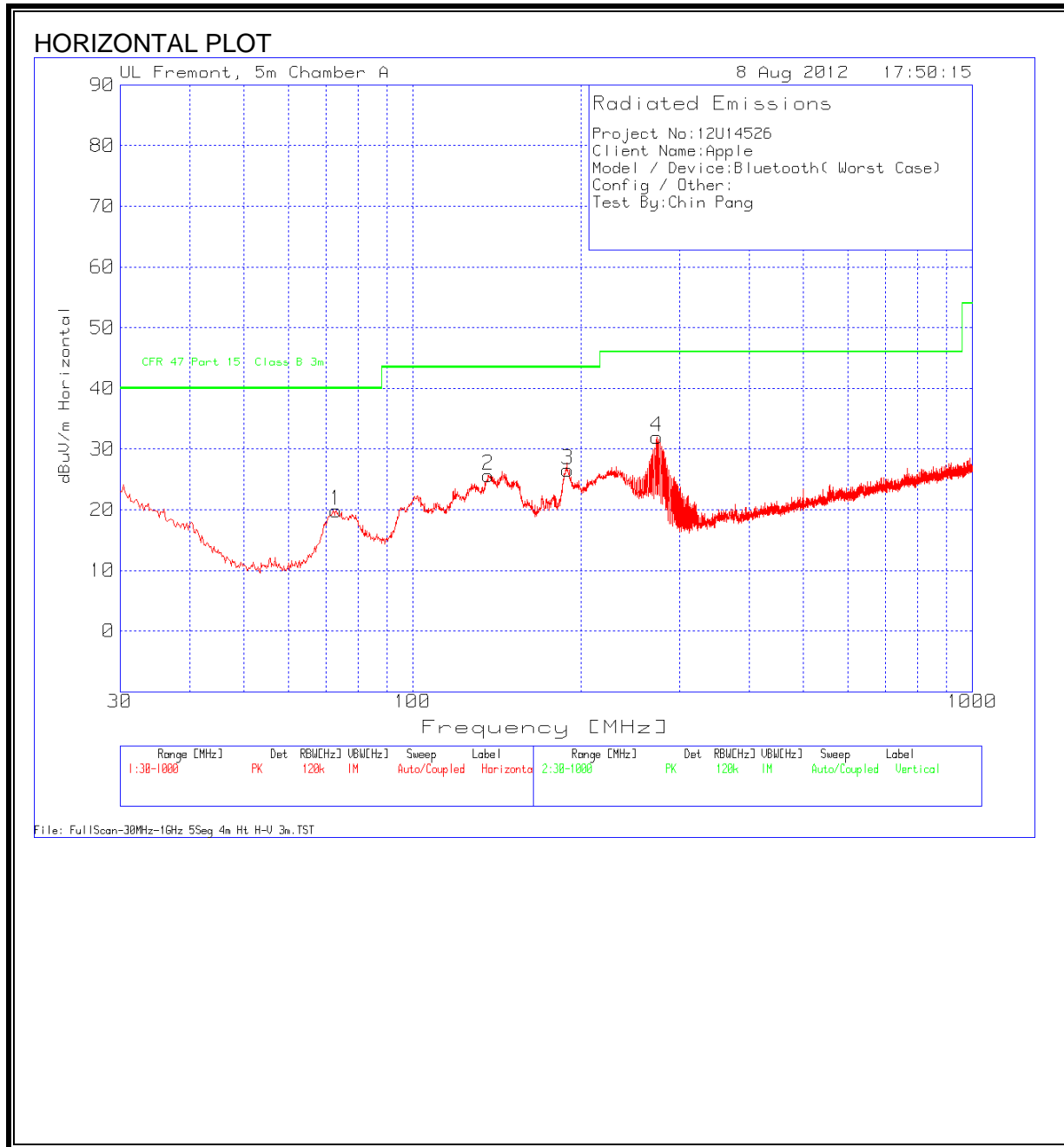

SPURIOUS EMISSIONS 30 TO 1000 MHz (WORST-CASE CONFIGURATION, VERTICAL)

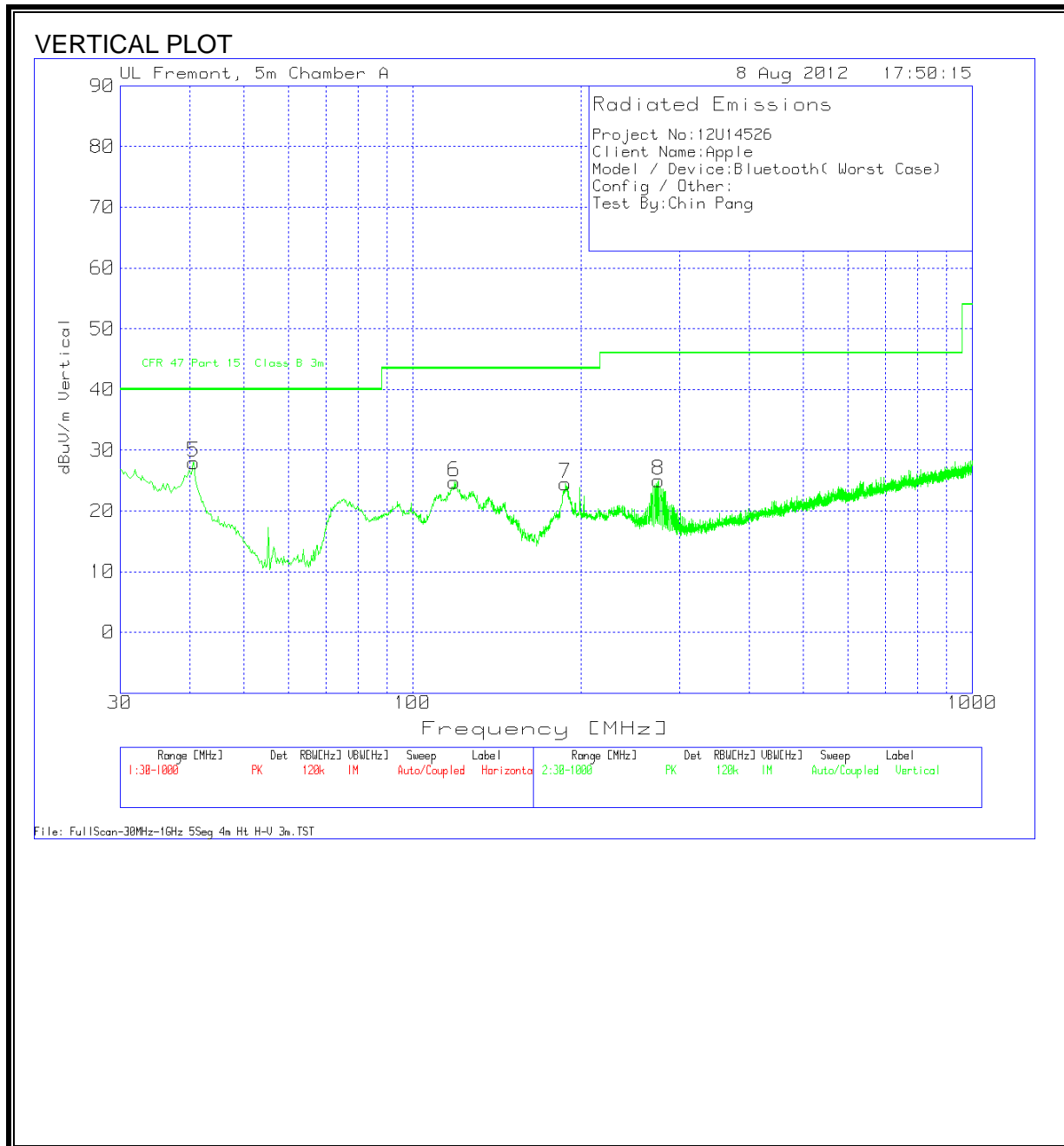

HORIZONTAL AND VERTICAL DATA

Project No:12U14526								
Client Name:Apple								
Model / Device:Bluetooth(Worst Case)								
Config / Other:								
Test By:Chin Pang								
Horizontal 30 - 1000MHz								
Frequency	Reading	Detector	25MHz-1GHz	T243 Sunol	dBuV/m	CFR 47 Part 15	Margin	Polarity
73.0336	38.91	PK	-27.1	8.1	19.91	40	-20.09	Horz
136.6147	39.34	PK	-26.7	13	25.64	43.5	-17.86	Horz
189.3405	41.57	PK	-26.3	11.3	26.57	43.5	-16.93	Horz
273.0815	44.69	PK	-25.9	13.2	31.99	46	-14.01	Horz
Vertical 30 - 1000MHz								
Frequency	Reading	Detector	25MHz-1GHz	T243 Sunol	dBuV/m	CFR 47 Part 15	Margin	Polarity
40.6615	41.74	PK	-27.3	13.5	27.94	40	-12.06	Vert
118.781	37.53	PK	-26.7	13.9	24.73	43.5	-18.77	Vert
187.5959	39.46	PK	-26.3	11.3	24.46	43.5	-19.04	Vert
275.02	37.57	PK	-25.9	13.3	24.97	46	-21.03	Vert

9. AC POWER LINE CONDUCTED EMISSIONS

LIMITS

FCC §15.207 (a)

RSS-Gen 7.2.2

Frequency of Emission (MHz)	Conducted Limit (dBuV)	
	Quasi-peak	Average
0.15-0.5	66 to 56	56 to 46
0.5-5	56	46
5-30	60	50

*Decreases with the logarithm of the frequency.

TEST PROCEDURE

ANSI C63.4

RESULTS

6 WORST EMISSIONS

Project No:12U14526									
Client Name:Apple									
Model/Device:Bluetooth (Worst Case)									
Test Volt/Freq:115VAC 60Hz									
Test By:Chin Pang									
Line-L1 .15 - 30MHz									
Test Freq	Meter Rea	Detector	T24 IL L1.T	LC Cables	dBuV	CISPR 22 C	Margin	CISPR 22 C	Margin
0.1635	63.18	PK	0.1	0	63.28	65.3	-2.02	-	-
0.1635	48.55	Av	0.1	0	48.65	-	-	55.3	-6.65
0.2445	55.66	PK	0.1	0	55.76	61.9	-6.14	-	-
0.2445	38.3	Av	0.1	0	38.4	-	-	51.9	-13.5
0.321	52.32	PK	0.1	0	52.42	59.7	-7.28	-	-
0.321	27.33	Av	0.1	0	27.43	-	-	49.7	-22.27
Line-L2 .15 - 30MHz									
Test Freq	Meter Rea	Detector	T24 IL L2.T	LC Cables	dBuV	CISPR 22 C	Margin	CISPR 22 C	Margin
0.159	53.36	PK	0.1	0	53.46	65.5	-12.04	-	-
0.159	40.25	Av	0.1	0	40.35	-	-	55.5	-15.15
0.2355	45.9	PK	0.1	0	46	62.3	-16.3	-	-
0.2355	28.74	Av	0.1	0	28.84	-	-	52.3	-23.46
0.312	43.07	PK	0.1	0	43.17	59.9	-16.73	-	-
0.312	23.15	Av	0.1	0	23.25	-	-	49.9	-26.65

LINE 1 RESULTS

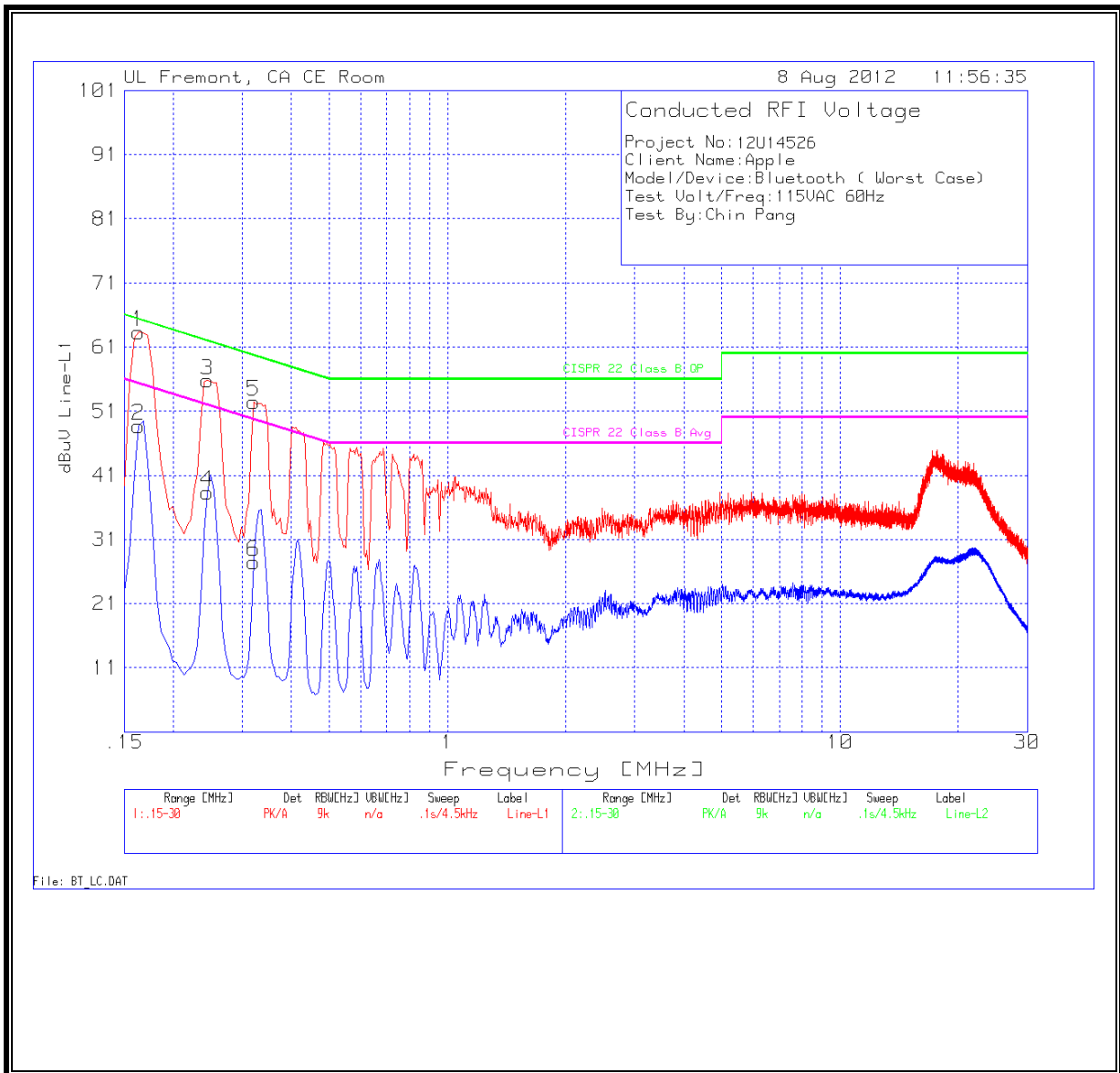

LINE 2 RESULTS

