



**FCC CFR47 PART 15 SUBPART C  
CERTIFICATION  
TEST REPORT**

**FOR**

**802.11b/g APPLE WIRELESS LAN CARD (AIRPORT)**

**MODEL NUMBER: A1026**

**BRAND NAME: APPLE AIRPORT WIRELESS LAN**

**FCC ID: BGCA1026**

**REPORT NUMBER: 02U1697-1C**

**ISSUE DATE: DECEMBER 31, 2002**

*Prepared for*  
**APPLE COMPUTER  
1 INFINITE LOOP  
CUPERTINO, CA 95014**

*Prepared by*  
**COMPLIANCE CERTIFICATION SERVICES  
561F MONTEREY ROAD,  
MORGAN HILL, CA 95037, USA  
TEL: (408) 463-0885  
FAX: (408) 463-0888**

## TABLE OF CONTENTS

<b>1. TEST RESULT CERTIFICATION .....</b>	<b>3</b>
<b>2. EUT DESCRIPTION .....</b>	<b>4</b>
<b>3. TEST METHODOLOGY .....</b>	<b>5</b>
<b>4. FACILITIES AND ACCREDITATION .....</b>	<b>5</b>
4.1. <i>FACILITIES AND EQUIPMENT .....</i>	<i>5</i>
4.2. <i>LABORATORY ACCREDITATIONS AND LISTINGS .....</i>	<i>5</i>
4.3. <i>TABLE OF ACCREDITATIONS AND LISTINGS .....</i>	<i>6</i>
<b>5. CALIBRATION AND UNCERTAINTY .....</b>	<b>7</b>
5.1. <i>MEASURING INSTRUMENT CALIBRATION .....</i>	<i>7</i>
5.2. <i>MEASUREMENT UNCERTAINTY .....</i>	<i>7</i>
5.3. <i>TEST AND MEASUREMENT EQUIPMENT .....</i>	<i>8</i>
<b>6. SETUP OF EQUIPMENT UNDER TEST .....</b>	<b>9</b>
<b>7. APPLICABLE RULES .....</b>	<b>13</b>
<b>8. TEST SETUP, PROCEDURE AND RESULT .....</b>	<b>16</b>
8.1. <i>WORST CASE MODES .....</i>	<i>16</i>
8.2. <i>6 dB BANDWIDTH .....</i>	<i>17</i>
8.3. <i>PEAK POWER .....</i>	<i>21</i>
8.4. <i>PEAK POWER SPECTRAL DENSITY .....</i>	<i>22</i>
8.5. <i>SPURIOUS EMISSIONS – CONDUCTED MEASUREMENTS .....</i>	<i>28</i>
8.6. <i>UNDESIRABLE EMISSIONS – RADIATED MEASUREMENTS .....</i>	<i>35</i>
8.7. <i>POWERLINE CONDUCTED EMISSIONS .....</i>	<i>38</i>
8.8. <i>SETUP PHOTOS .....</i>	<i>39</i>

# 1. TEST RESULT CERTIFICATION

**COMPANY NAME:** APPLE COMPUTER  
1 INFINITE LOOP  
CUPERTINO, CA 95014

**EUT DESCRIPTION:** 802.11B/G APPLE WIRELESS LAN CARD

**MODEL NAME:** A1026

**DATE TESTED:** DECEMBER 9 – DECEMBER 24, 2002

APPLICABLE STANDARDS	
STANDARD	TEST RESULTS
FCC PART 15 SUBPART C	NO NON-COMPLIANCE NOTED

Compliance Certification Services, Inc. tested the above equipment in accordance with the requirements set forth in the above standards. The test results show that the equipment tested is capable of demonstrating compliance with the requirements as documented in this report.

**Note:** This document reports conditions under which testing was conducted and results of tests performed. This document may not be altered or revised in any way unless done so by Compliance Certification Services and all revisions are duly noted in the revisions section. Any alteration of this document not carried out by Compliance Certification Services will constitute fraud and shall nullify the document.

Approved & Released For CCS By:

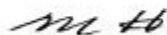

---

MIKE HECKROTTE  
CHIEF ENGINEER  
COMPLIANCE CERTIFICATION SERVICES

Tested By:



---

NEELESH RAJ  
EMC ENGINEER  
COMPLIANCE CERTIFICATION SERVICES

## 2. EUT DESCRIPTION

The Apple Wireless Lan Card (AirPort), code name P50, operates in the 2.4GHz unlicensed Industrial, Scientific and Medical band and used Direct Sequence Spread Spectrum and OFDM communication techniques. This device uses the Broadcom model BCM94306MP chip and is compliant with IEEE Std 802.11(b) – 1999 and draft IEEE Std 802.11g - 2002. The BCM94306MP provides wireless data communications at rates of up to 54Mbps, depending on the coding techniques employed and the range of the system.

Modulation	DSSS
Frequency Band	2400 - 2483.5 MHz
Operating Frequency	
Model A1026	2412 - 2462 (5 MHz Spacing)
Conducted Power	15 dBm
Channel Access Protocol	DSSS
Mode of Operation	Simplex
Antennas	Internal Inverted F Internal Patch External Patch External Dipole
Brand Name	Apple Airport Wireless LAN
Kind of Equipment	Transceiver, installed in a desktop, portable or base station (product is an internal plug-in card)
Application	Data transmission
Further Description	transmits and receives data from remote CPU
Standard Compliance	Compliant with Draft Std 802.11g - 2002

For P50, 802.11g  
Bandwidth: 22 MHz  
Emission Designator: 22M0F7D

The EUT has a peak output power of 18.4dBm and a max antenna gain of 6.24dBi.

### **3. TEST METHODOLOGY**

The tests documented in this report were performed in accordance with ANSI C63.4 and FCC CFR 47 2.1046, 2.1047, 2.1049, 2.1051, 2.1053, 2.1055, 2.1057, and 15.407.

### **4. FACILITIES AND ACCREDITATION**

#### **4.1. FACILITIES AND EQUIPMENT**

The open area test sites and conducted measurement facilities used to collect the radiated data are located at 561F Monterey Road, Morgan Hill, California, USA. The sites are constructed in conformance with the requirements of ANSI C63.7, ANSI C63.4 and CISPR Publication 22.







All receiving equipment conforms to CISPR Publication 16-1, "Radio Interference Measuring Apparatus and Measurement Methods."

Radiated Emission measurements were performed at the Apple Computer 10 meter semi-anechoic Test Site (Evelyn 1), located at 123 East Evelyn Ave., Mountain View, California. Conducted Emissions were performed at the Apple Computer EMC compliance lab located at 20650 Valley Green Drive, Cupertino, California

#### **4.2. LABORATORY ACCREDITATIONS AND LISTINGS**

The test facilities used to perform radiated and conducted emissions tests are accredited by National Voluntary Laboratory Accreditation Program for the specific scope of accreditation under Lab Code: 200065-0 to perform Electromagnetic Interference tests according to FCC PART 15 AND CISPR 22 requirements. No part of this report may be used to claim or imply product endorsement by NVLAP or any agency of the US Government. In addition, the test facilities are listed with Federal Communications Commission (reference no: 31040/SIT (1300B3) and 31040/SIT (1300F2)).

### 4.3. TABLE OF ACCREDITATIONS AND LISTINGS

Country	Agency	Scope of Accreditation	Logo
USA	NVLAP*	FCC Part 15, CISPR 22, AS/NZS 3548, IEC 61000-4-2, IEC 61000-4-3, IEC 61000-4-4, IEC 61000-4-5, IEC 61000-4-6, IEC 61000-4-8, IEC 61000-4-11, CNS 13438	 200065-0
USA	FCC	3/10 meter Open Area Test Sites to perform FCC Part 15/18 measurements	 1300
Japan	VCCI	CISPR 22 Two OATS and one conducted Site	 R-1014, R-619, C-640
Norway	NEMKO	EN50081-1, EN50081-2, EN50082-1, EN50082-2, IEC61000-6-1, IEC61000-6-2, EN50083-2, EN50091-2, EN50130-4, EN55011, EN55013, EN55014-1, EN55104, EN55015, EN61547, EN55022, EN55024, EN61000-3-2, EN61000-3-3, EN60945, EN61326-1	 ELA 117
Norway	NEMKO	EN60601-1-2 and IEC 60601-1-2, the Collateral Standards for Electro-Medical Products. MDD, 93/42/EEC, AIMD 90/385/EEC	 ELA-171
Taiwan	BSMI	CNS 13438	 SL2-IN-E-1012
Canada	Industry Canada	RSS210 Low Power Transmitter and Receiver	 IC2324 A,B,C, and F

\* No part of this report may be used to claim or imply product endorsement by NVLAP or any agency of the US Government.

## 5. CALIBRATION AND UNCERTAINTY

### 5.1. MEASURING INSTRUMENT CALIBRATION

The measurement instruments utilized to perform the tests documented in this report have been calibrated in accordance with the manufacturer's recommendations, and are traceable to national standards.

### 5.2. MEASUREMENT UNCERTAINTY

Where relevant, the following measurement uncertainty levels have been estimated for tests performed on the apparatus:

<b>Radiated Emission</b>	
30MHz – 200 MHz	+/- 3.3dB
200MHz – 1000MHz	+4.5/-2.9dB
1000MHz – 2000MHz	+4.6/-2.2dB
<b>Power Line Conducted Emission</b>	
150kHz – 30MHz	+/-2.9

Any results falling within the above values are deemed to be marginal.

### 5.3. TEST AND MEASUREMENT EQUIPMENT

The following test and measurement equipment was utilized for the tests documented in this report:

TEST EQUIPMENT LIST				
Name of Equipment	Manufacturer	Model No.	Serial No.	Due Date
Signal Generator, 10 MHz ~ 20 GHz	HP	83732B	US3449059	3/29/03
Quasi-Peak Adaptor	HP	85650A	2811A01335	5/23/03
SA Display Section 1	HP	85662A	3026A19146	5/23/03
SA RF Section, 22 GHz	HP	85660B	2140A01296	5/23/03
Oscilloscope, 100MHz 4Ch.	HP	54601A	3106A00123	11/6/03
Spectrum Analyzer	HP	8593EM	3710A00205	6/11/03
Spectrum Analyzer	HP	8564E	3943A01643	7/22/03
DC Power Supply	KENWOOD	PA36-3A	N/A	N/A
Environmental Test Chamber	THERMOTRON	SE600-10-10	29800	3/18/03
Power Meter	AGLIENT	E4416A	GB41291160	8/9/03
Power Sensor	AGLIENT	E44164	US40440755	8/9/03

Equipment Description	Model Number	Serial Number	Last Calibration	Next Calibration
Spectrum Analyzer	Rohde & Schwarz ESI	1088.7490_26	30 Aug 2002	30 Aug 2003
Receiver	ESI 26	1088.7490_26	30 Aug 2002	30 Aug 2003
Antenna	EMCO 3115	9205-3852	5 Sep 2000	5 Sep 2003
Antenna	18-26 GHz Horn	1264	1 Sep 2001	1 Nov 2003
Amplifier	Apple1m	1	12 Dec 2002	12 Dec 2003
Amplifier	HP 8449B (1-26.5 GHz)	3008A00713	4 Mar 2002	4 Mar 2003
Cable	Flexco FC182	FC182_4m	15 Dec 2002	15 Dec 2003



## 6. SETUP OF EQUIPMENT UNDER TEST

### SETUP INFORMATION FOR TRANSMITTER TESTS

#### SUPPORT EQUIPMENT

TEST PERIPHERALS				
Device Type	Manufacturer	Model Number	Serial Number	FCC ID
LAPTOP	APPLE	POWERBOOK G4	SQT24300RDT2	N/A
LAPTOP	APPLE	POWERBOOK G4	SQT20600IDUT	N/A
IBOOK	APPLE	IBOOK	PT324110	N/A
MONITOR	APPLE	M7768	N/A	DoC
MOUSE	APPLE	N/A	N/A	N/A
KYB	APPLE	N/A	NK9021G3UF86	N/A

#### I/O CABLES

TEST I / O CABLES								
Cable No	I/O Port	# of I/O Port	Connector Type	Type of Cable	Cable Length	Data Traffic	Bundled	Remark
1	PWR	1	AC PWR	UNSHIELDED	1.6M	NO	NO	
2	VIDEO/PWR	1	SCSI	SHIELDED	1M	YES	NO	
3	USB	1	USB	SHIELDED	1M	YES	NO	KEYBOARD
4	USB	1	USB	SHIELDED	0.62M	YES	NO	MOUSE

#### TEST SETUP

The EUT is installed in computer.

**SETUP DIAGRAM FOR TRANSMITTER TESTS**

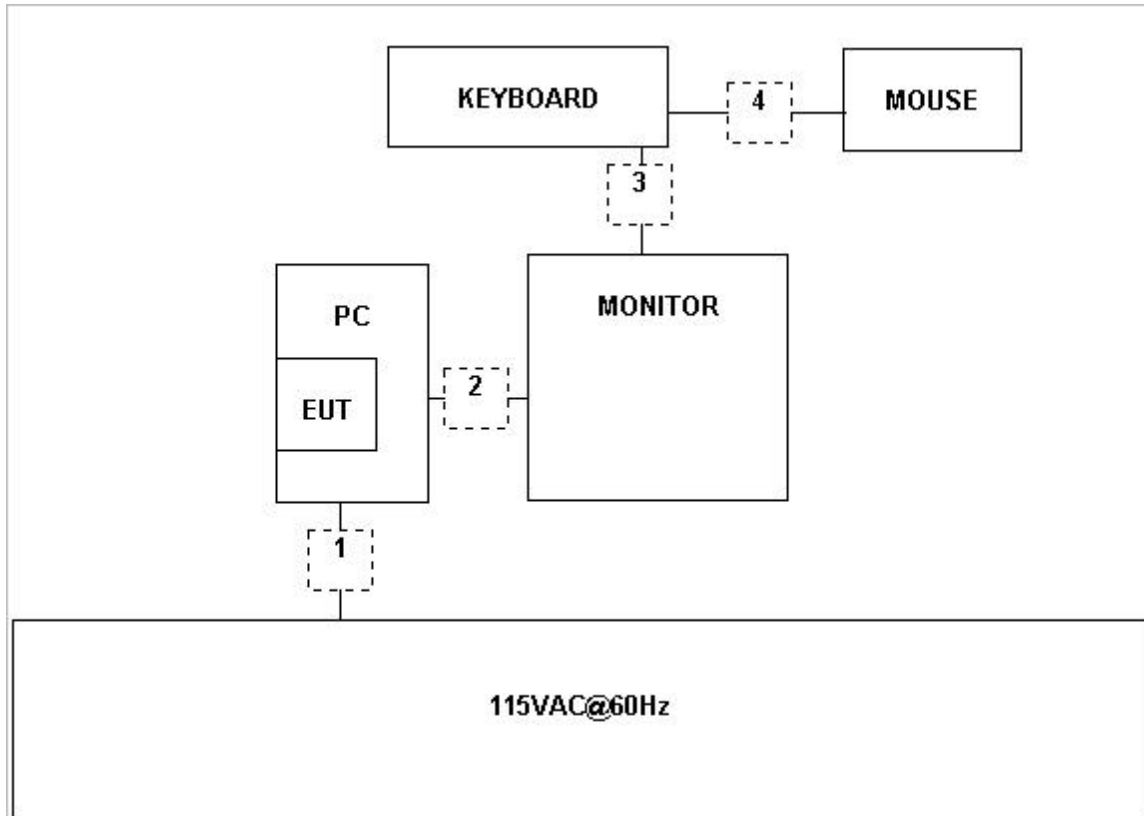

**SETUP INFORMATION FOR DIGITAL DEVICE TESTS**

**SUPPORT EQUIPMENT**

TEST PERIPHERALS				
Device Type	Manufacturer	Model Number	Serial Number	FCC ID
LAPTOP	APPLE	POWERBOOK G4	SQT24300RDT2	N/A
LAPTOP	APPLE	POWERBOOK G4	SQT20600IDUT	N/A
IBOOK	APPLE	IBOOK	PT324110	N/A
MONITOR	APPLE	M7768	N/A	DoC
MOUSE	APPLE	N/A	N/A	N/A
KYB	APPLE	N/A	NK9021 G3UF86	N/A

**I/O CABLES**

TEST I / O CABLES								
Cable No	I/O Port	# of I/O Port	Connector Type	Type of Cable	Cable Length	Data Traffic	Bundled	Remark
1	PWR	1	AC PWR	UNSHIELDED	1.6M	NO	NO	
2	VIDEO/PWR	1	SCSI	SHIELDED	1M	YES	NO	
3	USB	1	USB	SHIELDED	1M	YES	NO	KEYBOARD
4	USB	1	USB	SHIELDED	0.62M	YES	NO	MOUSE

**TEST SETUP**

The EUT is installed in the computer.

**SETUP DIAGRAM FOR DIGITAL DEVICE TESTS**

Radiated Test Setup - Top View

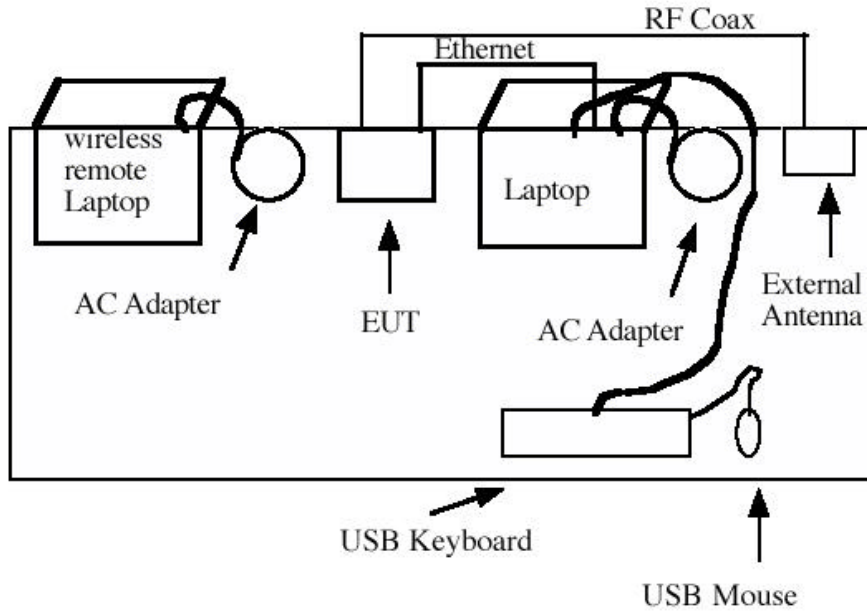

## 7. APPLICABLE RULES

### **§15.247 (a)- BANDWIDTH**

(2) For direct sequence systems, the minimum 6 dB bandwidth shall be at least 500 kHz.

### **§15.247 (b)- POWER OUTPUT**

The maximum peak output power of the intentional radiator shall not exceed the following:

(3) For systems using digital modulation in the 902-928 MHz, 2400-2483.5 MHz , and 5725-5850 MHz bands: 1 watt.

(4) Except as shown in paragraphs (b)(3) (i), (ii) and (iii) of this section, if transmitting antennas of directional gain greater than 6 dBi are used the peak output power from the intentional radiator shall be reduced below the stated values in paragraphs (b)(1) or (b)(2) of this section, as appropriate, by the amount in dB that the directional gain of the antenna exceeds 6 dBi.

### **§15.247 (b)- RADIO FREQUENCY EXPOSURE**

(5) Systems operating under the provisions of this section shall be operated in a manner that ensures that the public is not exposed to radio frequency energy levels in excess of the Commission's guidelines. See §1.1307(b)(1) of this chapter.

### **§15.247 (c)- SPURIOUS EMISSIONS**

In any 100 kHz bandwidth outside the frequency band in which the spread spectrum intentional radiator is operating, the radio frequency power that is produced by the intentional radiator shall be at least 20 dB below that in the 100 kHz bandwidth within the band that contains the highest level of the desired power, based on either an RF conducted or a radiated measurement. Attenuation below the general limits specified in §15.209(a) is not required. In addition, radiated emissions which fall in the restricted bands, as defined in §15.205(a), must also comply with the radiated emission limits specified in §15.209(a) (see §15.205(c)).

### **§15.247 (d)- PEAK POWER SPECTRAL DENSITY**

(d) For direct sequence systems, the peak power spectral density conducted from the intentional radiator to the antenna shall not be greater than 8 dBm in any 3 kHz band during any time interval of continuous transmission.

(f) The direct sequence operating of the hybrid system, with the frequency hopping operation turned off, shall comply with the power density requirements of paragraph (d) of this section.

**§15.205- RESTRICTED BANDS OF OPERATIONS**

(a) Except as shown in paragraph (d) of this section, only spurious emissions are permitted in any of the frequency bands listed below:

MHz	MHz	MHz	GHz
0.090 - 0.110	16.42 - 16.423	399.9 - 410	4.5 - 5.15
<sup>1</sup> 0.495 - 0.505	16.69475 - 16.69525	608 - 614	5.35 - 5.46
2.1735 - 2.1905	16.80425 - 16.80475	960 - 1240	7.25 - 7.75
4.125 - 4.128	25.5 - 25.67	1300 - 1427	8.025 - 8.5
4.17725 - 4.17775	37.5 - 38.25	1435 - 1626.5	9.0 - 9.2
4.20725 - 4.20775	73 - 74.6	1645.5 - 1646.5	9.3 - 9.5
6.215 - 6.218	74.8 - 75.2	1660 - 1710	10.6 - 12.7
6.26775 - 6.26825	108 - 121.94	1718.8 - 1722.2	13.25 - 13.4
6.31175 - 6.31225	123 - 138	2200 - 2300	14.47 - 14.5
8.291 - 8.294	149.9 - 150.05	2310 - 2390	15.35 - 16.2
8.362 - 8.366	156.52475 - 156.52525	2483.5 - 2500	17.7 - 21.4
8.37625 - 8.38675	156.7 - 156.9	2655 - 2900	22.01 - 23.12
8.41425 - 8.41475	162.0125 - 167.17	3260 - 3267	23.6 - 24.0
12.29 - 12.293	167.72 - 173.2	3332 - 3339	31.2 - 31.8
12.51975 - 12.52025	240 - 285	3345.8 - 3358	36.43 - 36.5
12.57675 - 12.57725	322 - 335.4	3600 - 4400	( <sup>2</sup> )
13.36 - 13.41			

<sup>1</sup> Until February 1, 1999, this restricted band shall be 0.490-0.510 MHz.

<sup>2</sup> Above 38.6

(b) Except as provided in paragraphs (d) and (e), the field strength of emissions appearing within these frequency bands shall not exceed the limits shown in Section 15.209. At frequencies equal to or less than 1000 MHz, compliance with the limits in Section 15.209 shall be demonstrated using measurement instrumentation employing a CISPR quasi-peak detector. Above 1000 MHz, compliance with the emission limits in Section 15.209 shall be demonstrated based on the average value of the measured emissions. The provisions in Section 15.35 apply to these measurements.

**§15.207- CONDUCTED LIMITS**

(a) For an intentional radiator which is designed to be connected to the public utility (AC) power line, the radio frequency voltage that is conducted back onto the AC power line on any frequency or frequencies within the band 450 kHz to 30 MHz shall not exceed 250 microvolts. Compliance with this provision shall be based on the measurement of the radio frequency voltage between each power line and ground at the power terminals.

**§15.209- RADIATED EMISSION LIMITS**

(a) Except as provided elsewhere in this Subpart, the emissions from an intentional radiator shall not exceed the field strength levels specified in the following table:

Frequency (MHz)	Field Strength (microvolts/meter)	Measurement Distance (meters)
30 - 88	100 **	3
88 - 216	150 **	3
216 - 960	200 **	3
Above 960	500	3

\*\* Except as provided in paragraph (g), fundamental emissions from intentional radiators operating under this Section shall not be located in the frequency bands 54-72 MHz, 76-88 MHz, 174-216 MHz or 470-806 MHz. However, operation within these frequency bands is permitted under other sections of this Part, e.g., Sections 15.231 and 15.241.

(b) In the emission table above, the tighter limit applies at the band edges.

Frequency Range (MHz)	Field Strength (uV/m at 3 m)	Field Strength (dBuV/m at 3 m)
30-88	100	40
88-216	150	43.5
216-960	200	46
Above 960	500	54

## 8. TEST SETUP, PROCEDURE AND RESULT

### 8.1. WORST CASE MODES

Three different data rates (1 Mb/s DSSS, 6 Mb/s OFDM, and 54 Mb/s OFDM) were investigated.

For radiated emissions below 1 GHz it was determined that the 54 Mb/s data rate produced the highest emissions.

For radiated emissions above 1 GHz it was determined that the 1 Mb/s data rate produced the highest output power.

For antenna port conducted tests it was determined that the 1 Mb/s data rate produced the highest output power.

For AC Mains power line emissions, the data rate had no effect.

Thus all final radiated emissions testing below 1 GHz was performed using the worst case 54 Mb/s OFDM modulation.

Thus all final radiated emissions testing above 1 GHz was performed using the worst case 1 Mb/s DSSS modulation.

Thus all final antenna port conducted tests were performed using the worst case 1 Mb/s DSSS modulation.

Thus all final AC Mains powerline emissions testing was performed using 54 Mb/s OFDM modulation.



## 8.2. 6 dB BANDWIDTH

### TEST SETUP

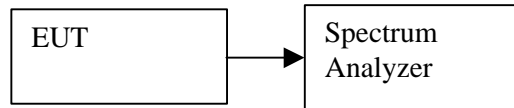

### TEST PROCEDURE

The transmitter output is connected to the spectrum analyzer. The RBW is set to 100 kHz and the VBW is set to 100 kHz. The sweep time is coupled.

### RESULTS

No non-compliance noted:

#### 2.4 GHz Band

Channel	Frequency (MHz)	B (kHz)	Limit (kHz)	Margin (kHz)
Low	2412	11230	500	10730
Middle	2437	10300	500	9800
High	2462	10270	500	9770

**6 DB BANDWIDTH (2.4 GHZ BAND)**

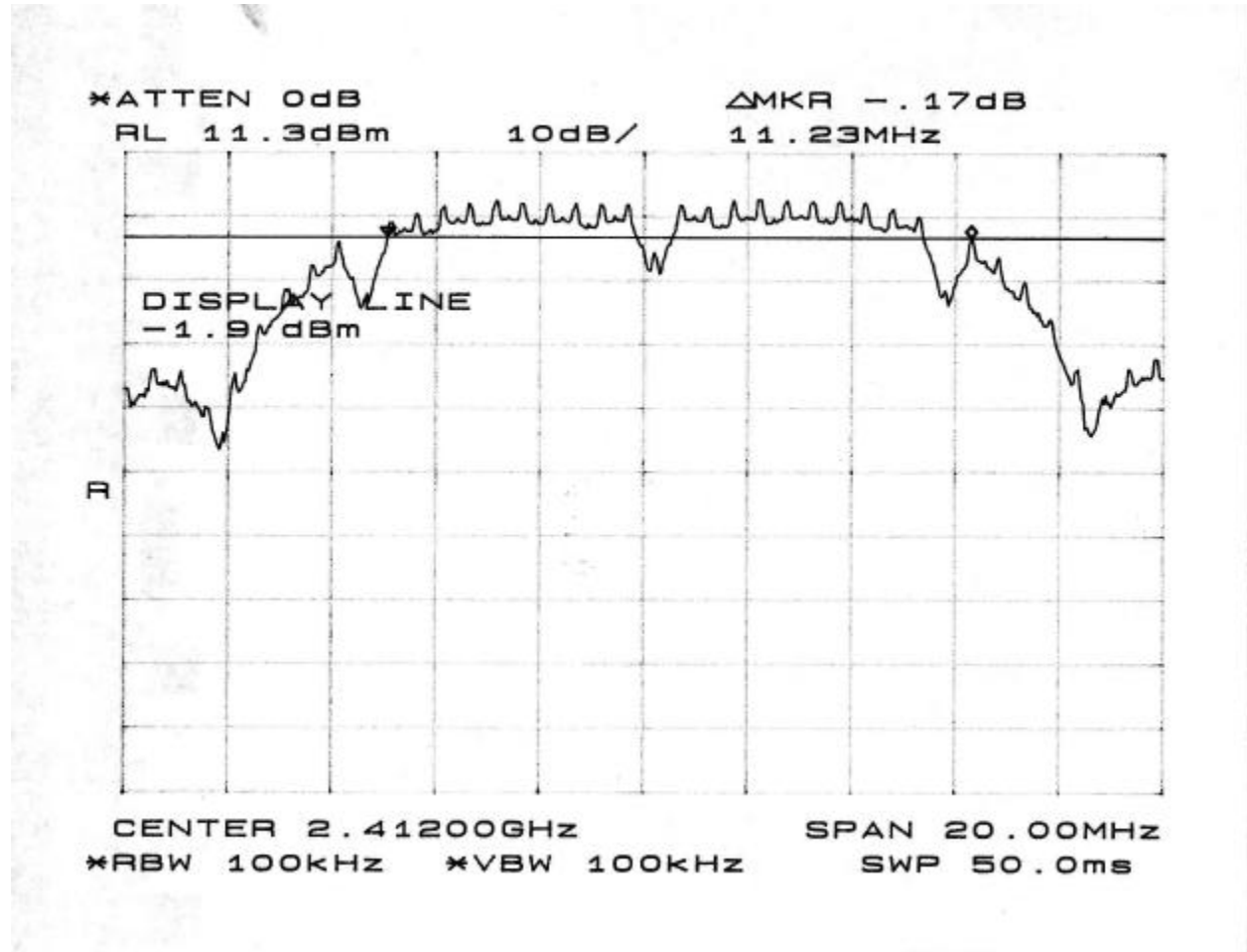

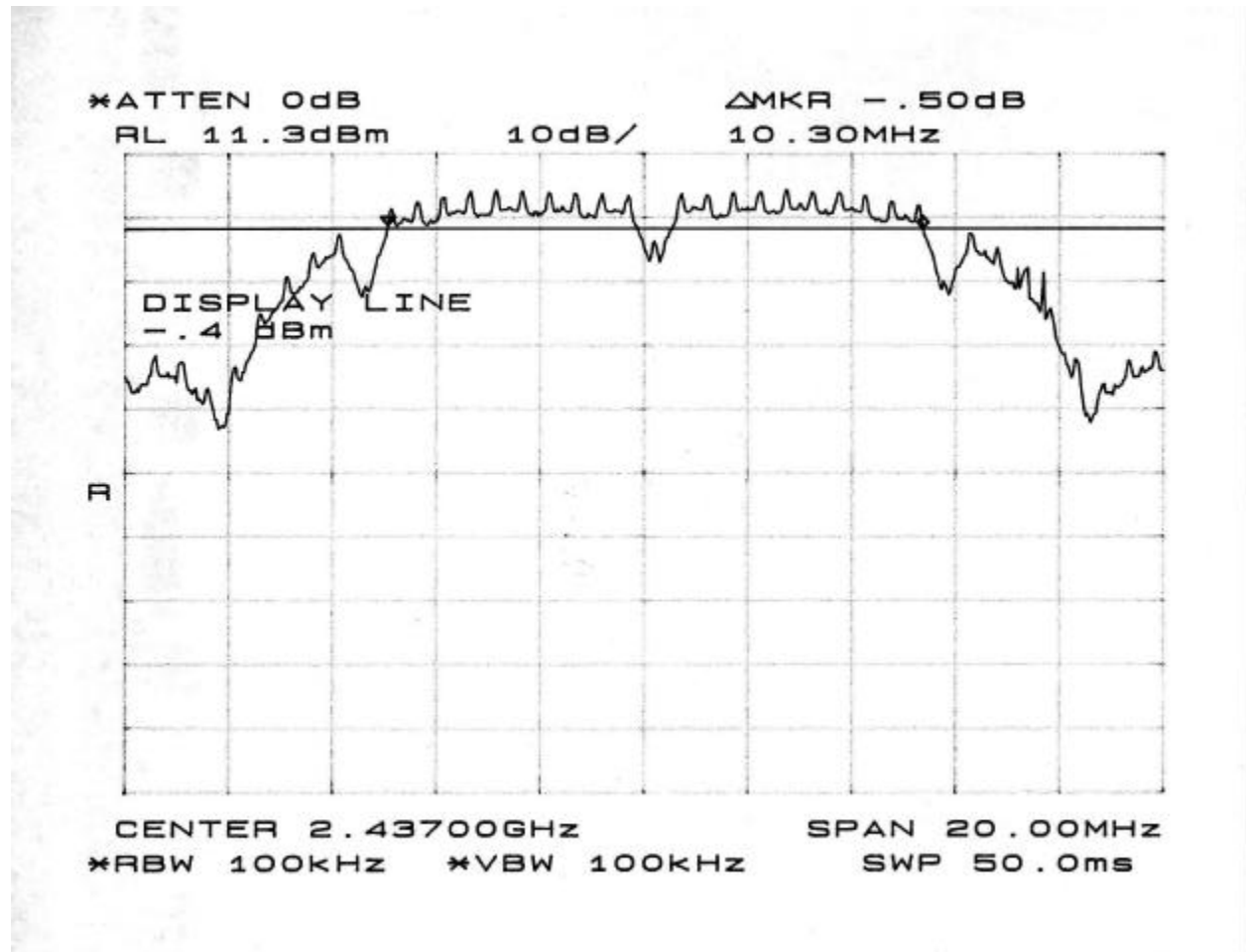

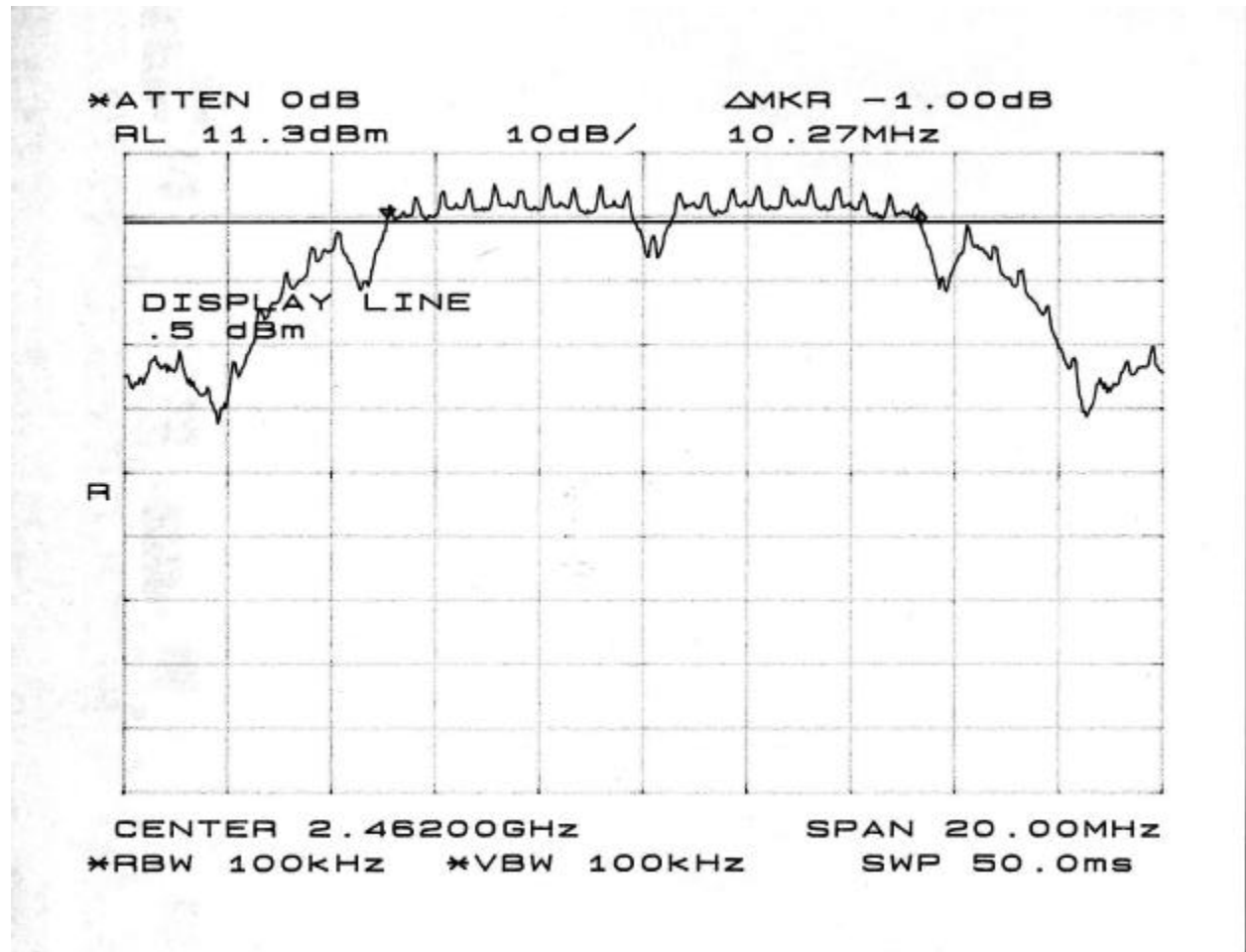

### 8.3. PEAK POWER

#### TEST SETUP

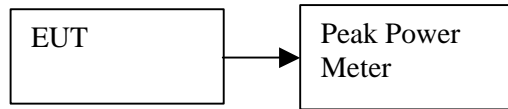

#### TEST PROCEDURE

The transmitter output is connected to the power meter. The power meter is set to read peak power.

#### LIMIT

The maximum antenna gain = 6.24 dBi, therefore the limit is 30 dBm.

#### RESULTS

No non-compliance noted:

##### 2.4 GHz Band

Channel	Frequency (MHz)	Peak Power (dBm)	Limit (dBm)	Margin (dB)
Low	2412	16.26	29.76	-13.50
Middle	2437	17.68	29.76	-12.8
High	2462	18.4	29.76	-11.36

## 8.4. PEAK POWER SPECTRAL DENSITY

### TEST SETUP

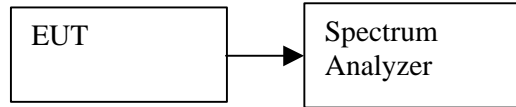

### TEST PROCEDURE

The transmitter output is connected to the spectrum analyzer, the maximum level in a 3 kHz bandwidth is measured with the spectrum analyzer using RBW = 3 kHz and VBW  $\geq$  3KHz, sweep time = span / 3 kHz, and video averaging is turned off. The PPSD is the highest level found across the emission in any 3 kHz band.

### RESULTS

No non-compliance noted:

#### 2.4 GHz Band

Channel	Frequency (MHz)	PPSD (dBm)	Limit (dBm)	Margin (dB)
Low	2412	-8.03	8	-16.03
Middle	2437	-8.20	8	-16.20
High	2462	-7.20	8	-15.20

**PPSD (2.4 GHZ BAND)**

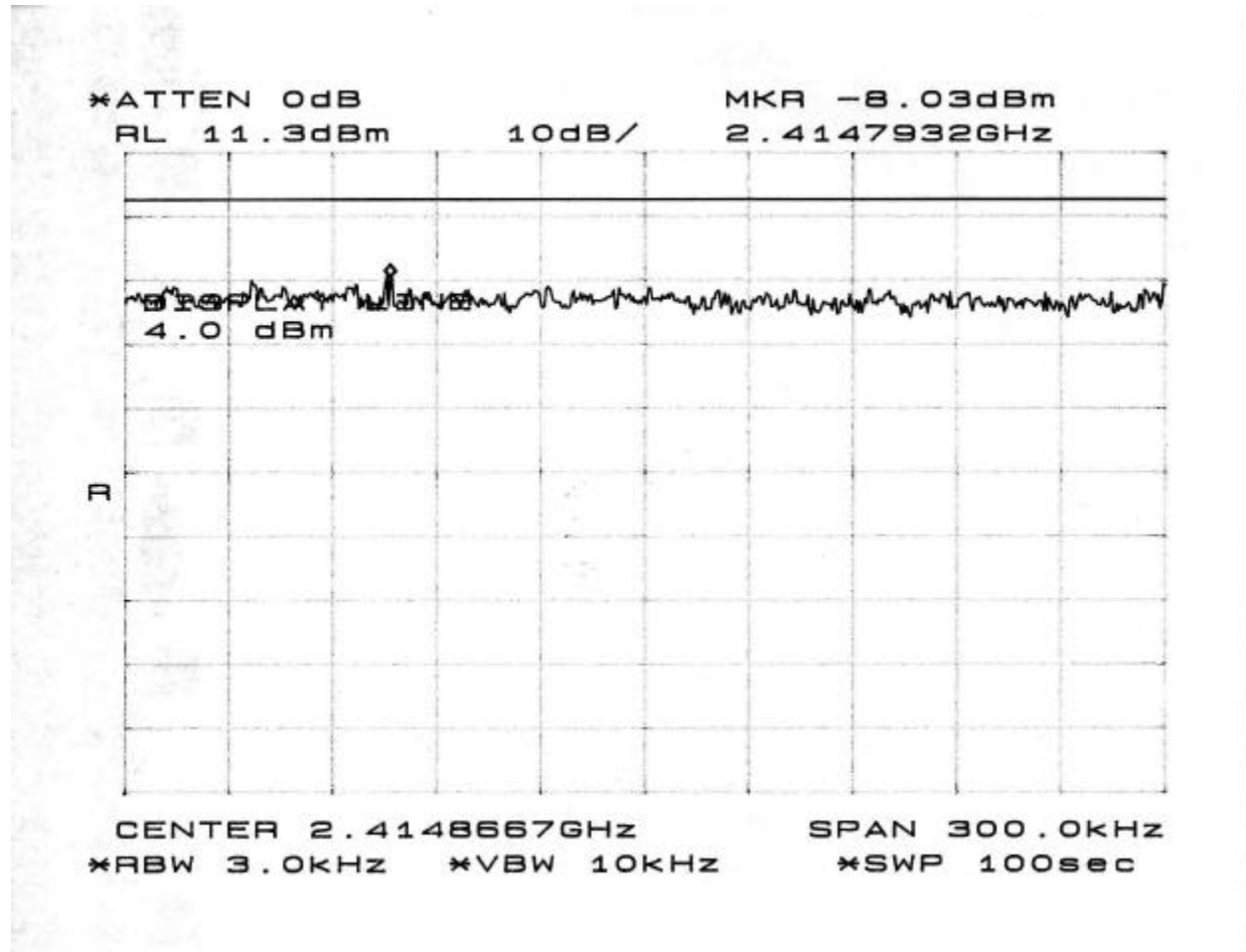

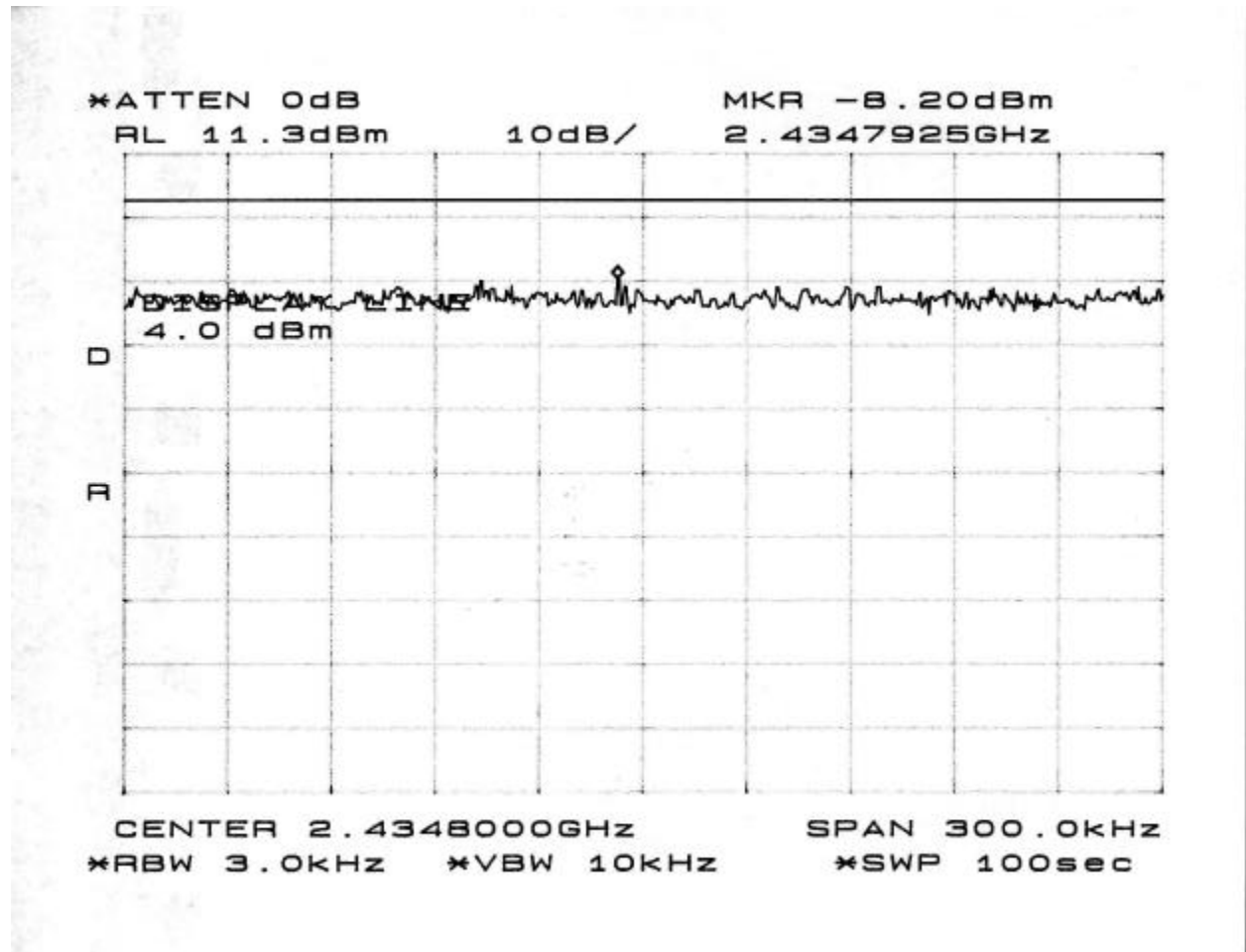



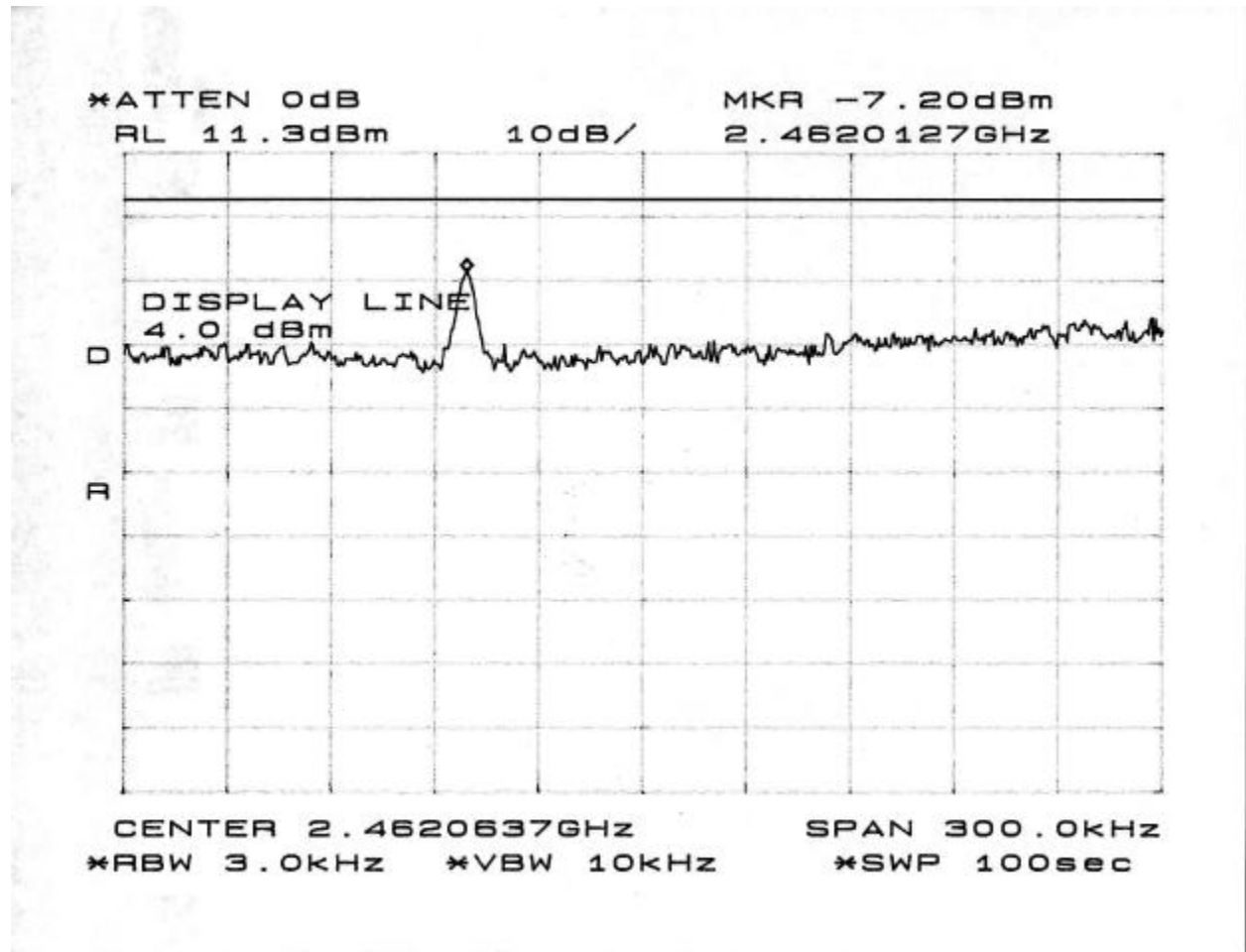

MAXIMUM PERMISSIBLE EXPOSURE

**CALCULATIONS**

Given

$$E = \sqrt{(30 * P * G) / d}$$

and

$$S = E^2 / 3770$$

where

E = Field Strength in Volts / meter

P = Power in Watts

G = Numeric antenna gain

d = distance in meters

S = Power Density in milliwatts / square centimeter

Combining equations and rearranging the terms to express the distance as a function of the remaining variables yields:

$$d = \sqrt{((30 * P * G) / (3770 * S))}$$

Changing to units of mW and cm, using:

$$P \text{ (mW)} = P \text{ (W)} / 1000 \text{ and}$$

$$d \text{ (cm)} = 100 * d \text{ (m)}$$

yields

$$d = 100 * \sqrt{((30 * (P / 1000) * G) / (3770 * S))}$$

$$d = 0.282 * \sqrt{(P * G / S)}$$

where

d = distance in cm

P = Power in mW

G = Numeric antenna gain

S = Power Density in mW / cm<sup>2</sup>

Substituting the logarithmic form of power and gain using:

$$P \text{ (mW)} = 10^{(P \text{ (dBm)} / 10)} \text{ and}$$

$$G \text{ (numeric)} = 10^{(G \text{ (dBi)} / 10)}$$

yields

$$d = 0.282 * 10^{((P + G) / 20)} / \sqrt{S} \quad \text{Equation (1)}$$

where

d = MPE safe distance in cm

P = Power in dBm

G = Antenna Gain in dBi

S = Power Density Limit in mW / cm<sup>2</sup>

## **RESULTS**

No non-compliance noted:

### **MAXIMUM PERMISSIBLE EXPOSURE (2.4 GHZ BAND)**

EUT output power = 18.4 dBm

Antenna Gain = 6.24 dBi

S = 1.0 mW / cm<sup>2</sup> from 1.1310 Table 1

Substituting these parameters into Equation (1) above:

MPE Safe Distance = 4.8 cm

## 8.5. SPURIOUS EMISSIONS – CONDUCTED MEASUREMENTS

Conducted RF measurements of the transmitter output were made to confirm that the EUT antenna port conducted emissions meet the specified limit and to identify any spurious signals that require further investigation or measurements on the radiated emissions site.

### TEST SETUP

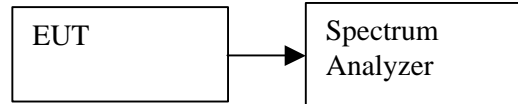

### TEST PROCEDURE

The transmitter output is connected to the spectrum analyzer. The resolution bandwidth is set to 100 kHz. The video bandwidth is set to 300 kHz.

Measurements are made over the 30 MHz to 26.5 GHz range with the transmitter set to the lowest, middle, and highest channels within the 2.4 GHz band.

Measurements are made over the 30 MHz to 40 GHz range with the transmitter set to the lowest, middle, and highest channels within the 5.8 GHz band.

### RESULTS

No non-compliance noted:

**CONDUCTED SPURIOUS EMISSIONS (2.4 GHZ BAND)**

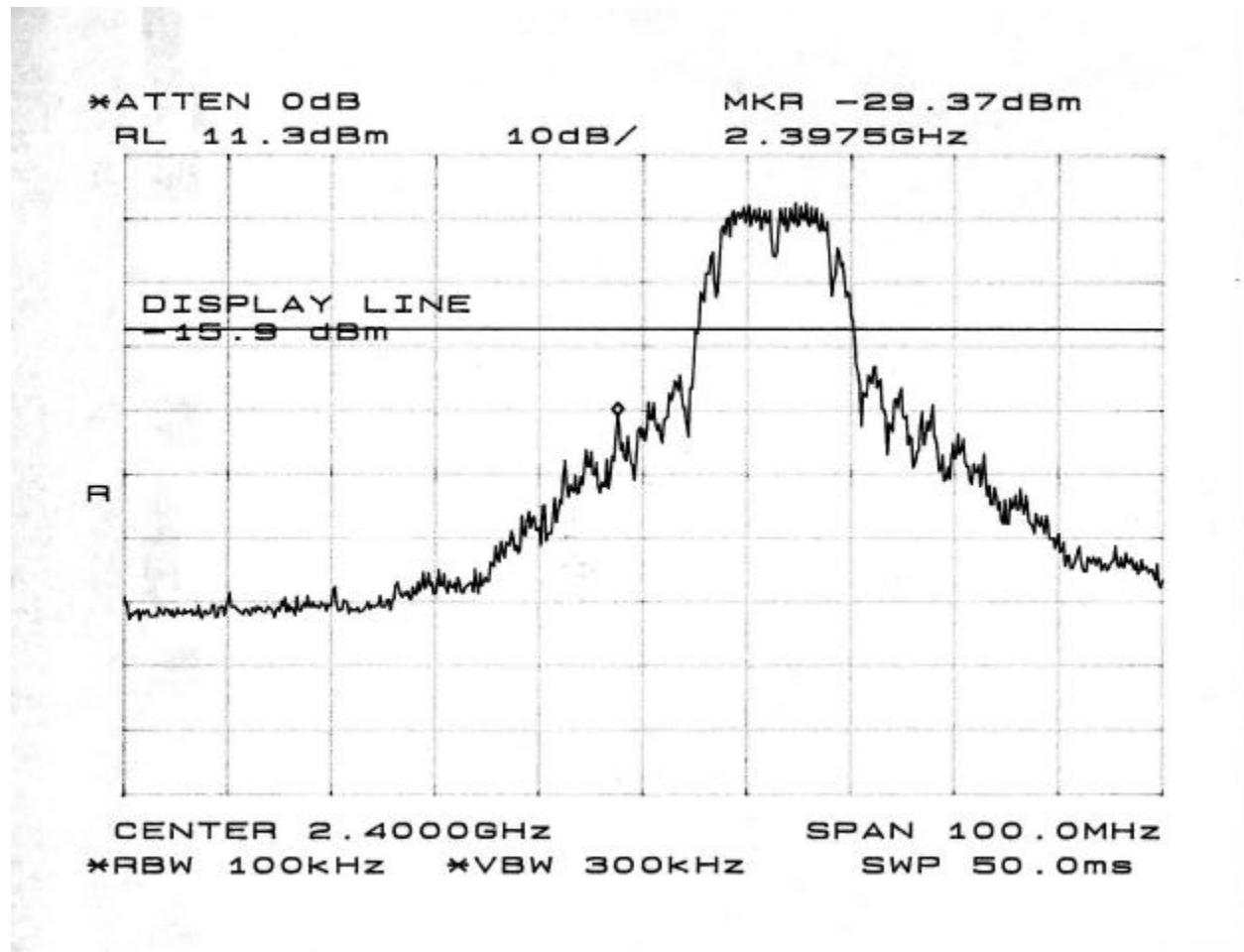

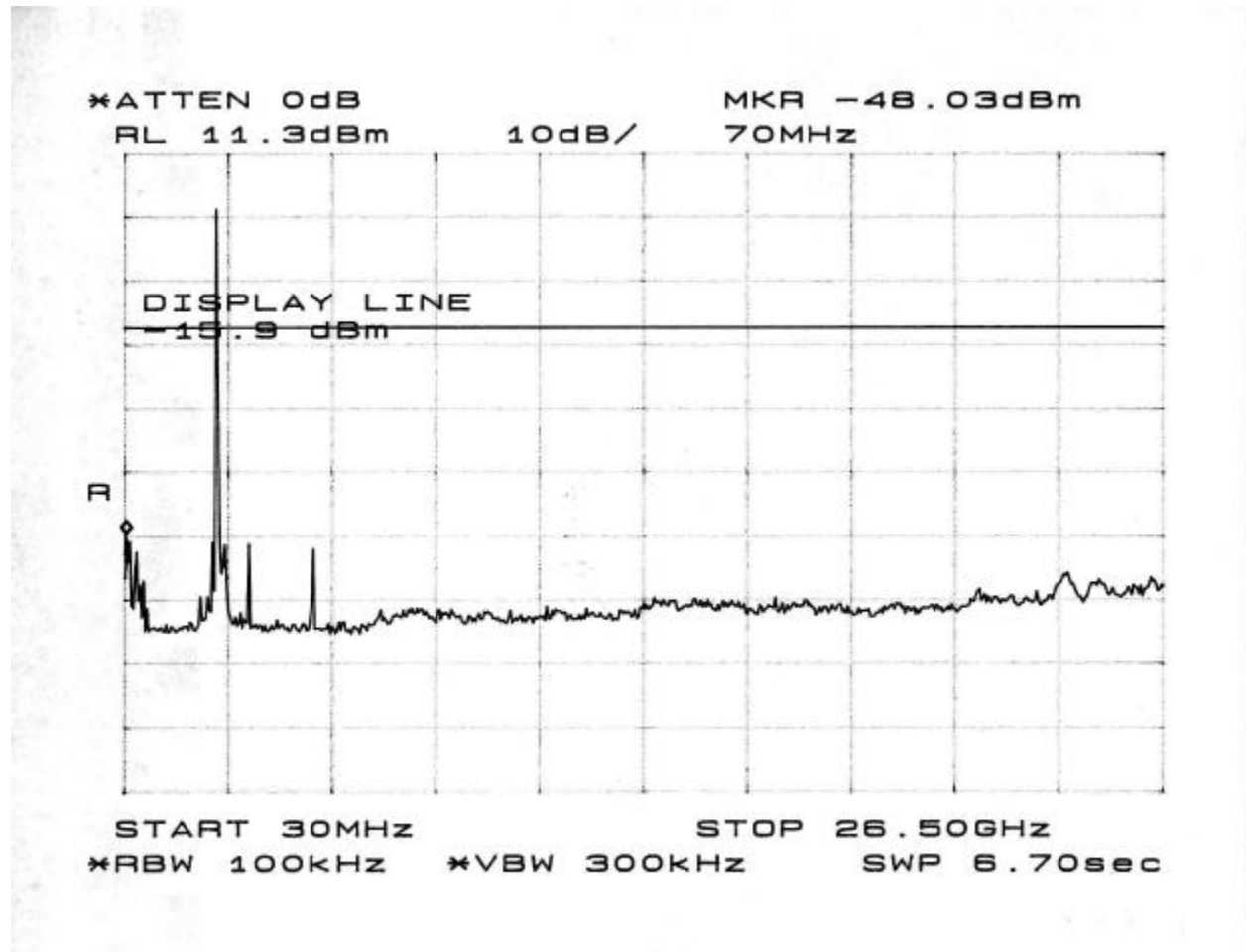

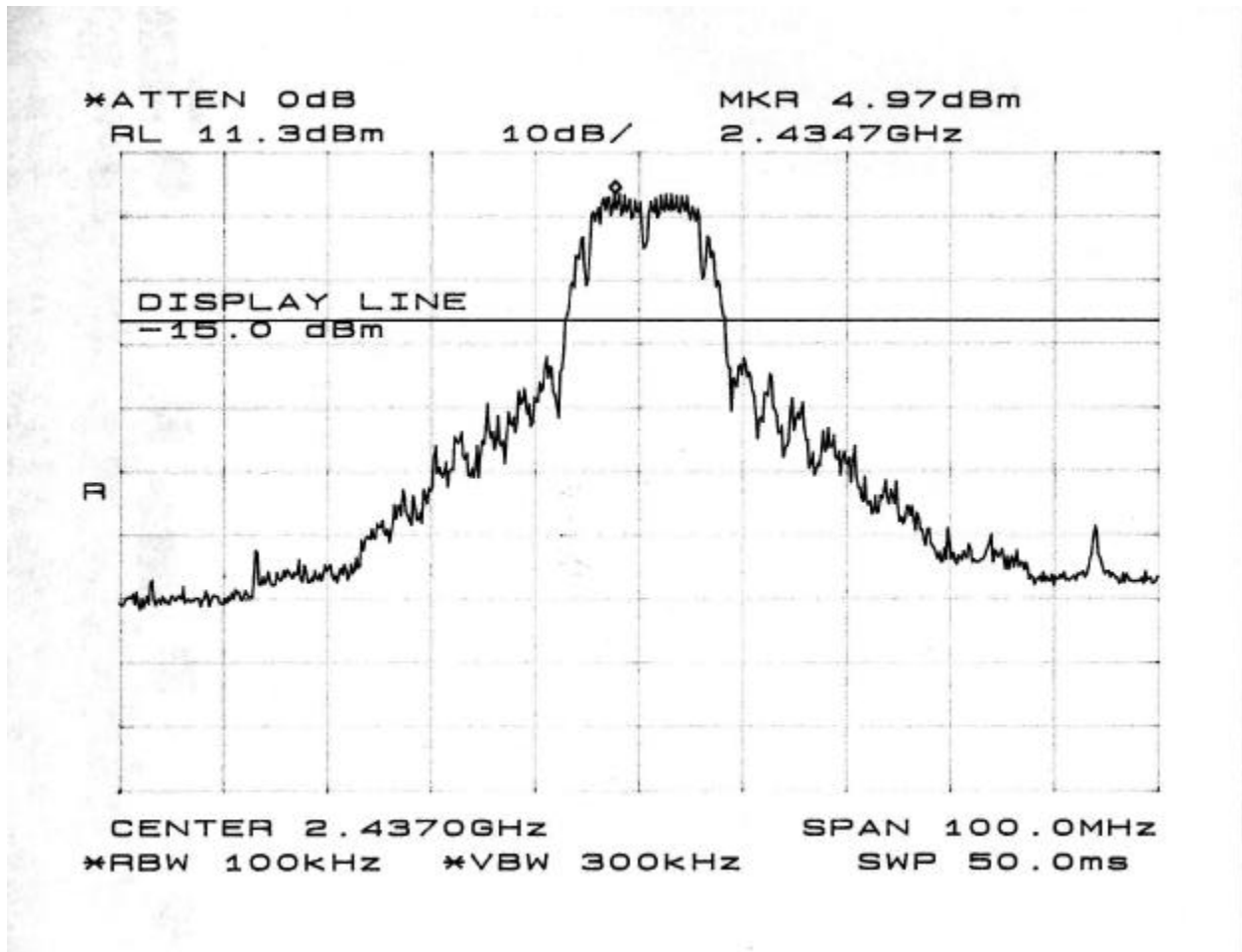

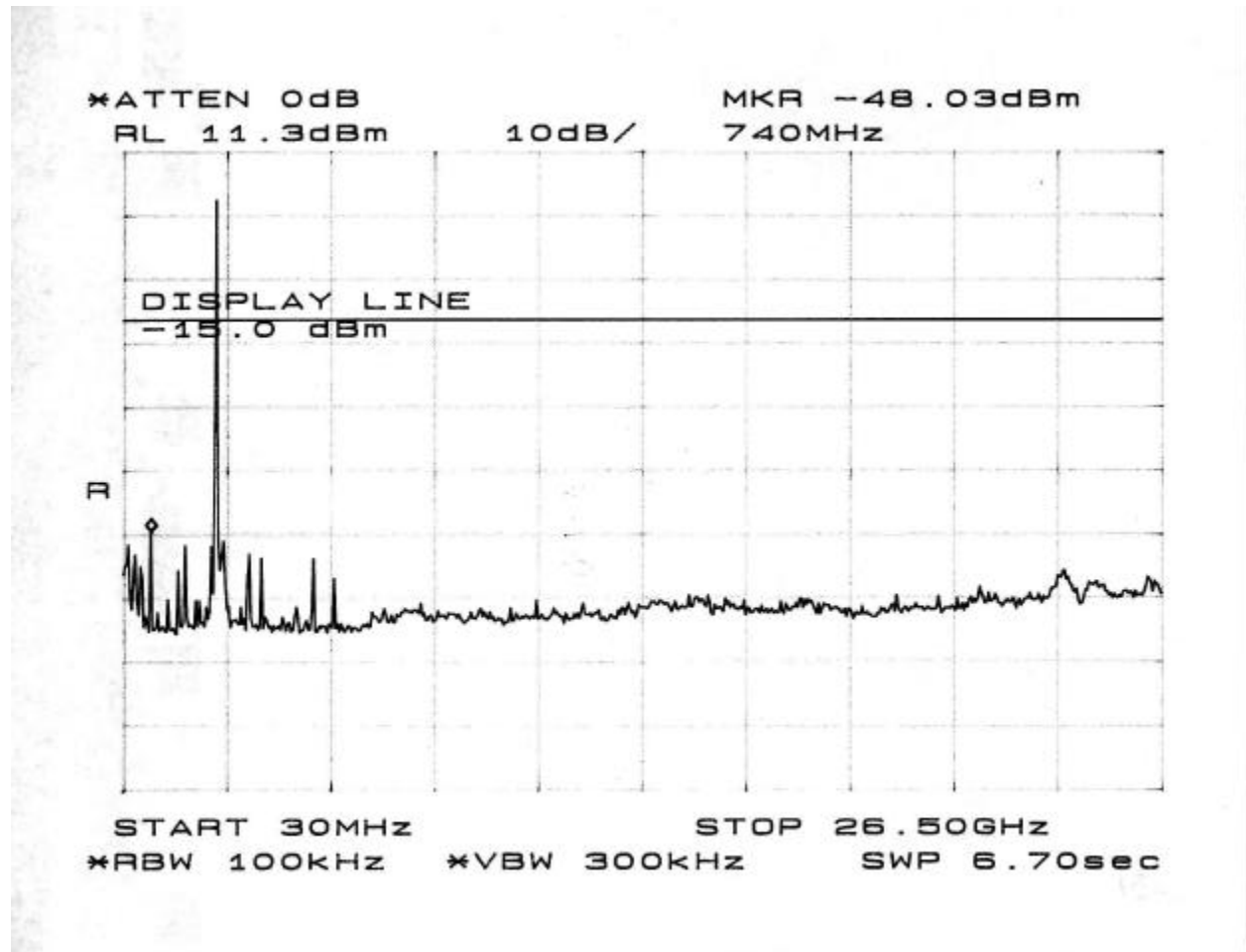



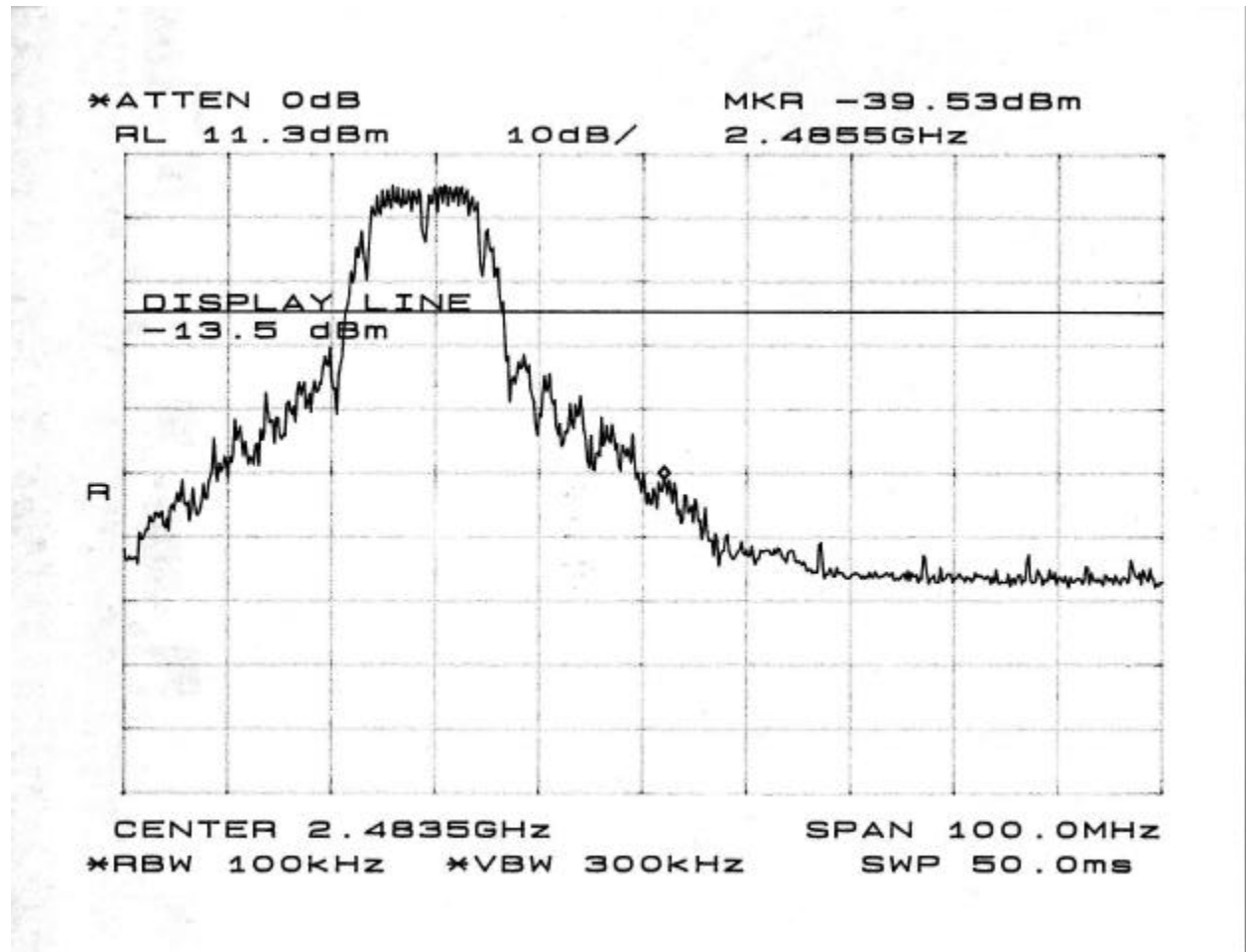

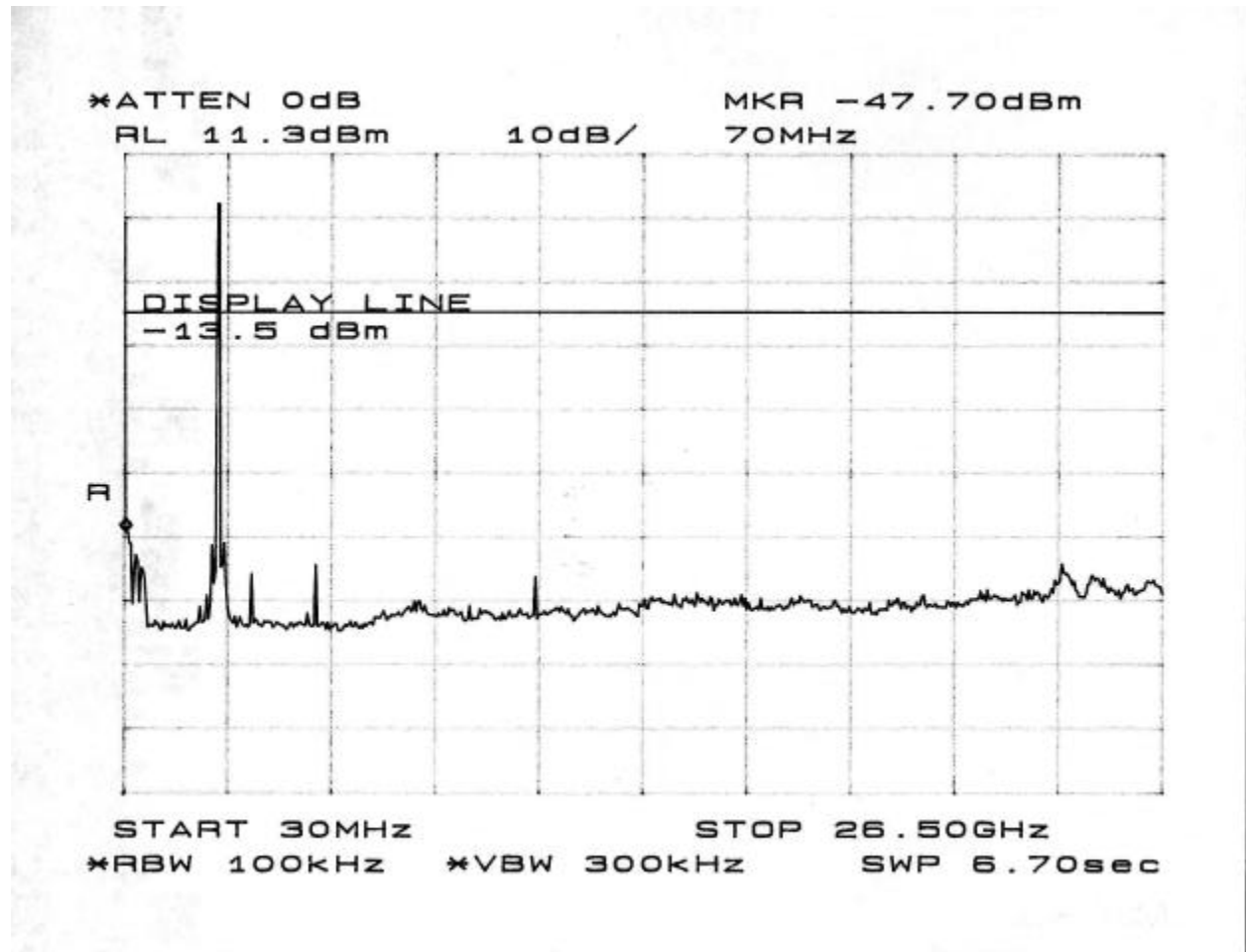

## **8.6. UNDESIRABLE EMISSIONS – RADIATED MEASUREMENTS**

### **TEST SETUP**

The EUT is placed on the wooden table. The antenna to EUT distance is 3 meters. The EUT is configured in accordance with ANSI C63.4/1992.

The EUT is set to transmit in a continuous mode.

### **TEST PROCEDURE**

For measurements below 1 GHz the resolution bandwidth is set to 100 kHz for peak detection measurements or 120 kHz for quasi-peak detection measurements. Peak detection is used unless otherwise noted as quasi-peak.

For measurements above 1 GHz, the resolution bandwidth is set to 1 MHz, then the video bandwidth is set to 1 MHz for peak measurements and 10 Hz for average measurements.

The spectrum from 30 MHz to 26 GHz is investigated with the transmitter set to the lowest, middle, and highest channels within the 2.4 GHz band.

The frequency range of interest is monitored at a fixed antenna height and EUT azimuth. The frequency span is set small enough to easily differentiate between broadcast stations, intermittent ambient signals and EUT emissions. The EUT is rotated through 360 degrees to maximize emissions received. The antenna is scanned from 1 to 4 meters above the ground plane to further maximize the suspected signal. Measurements were made with the antenna polarized in both the vertical and the horizontal positions.

### **TEST RESULTS**

No non-compliance noted:

**BAND EDGE RADIATED EMISSIONS (LOW CHANNEL, MIDDLE CHANNEL, HIGH CHANNEL)**

See Client's Harmonic, Spurious, & Bandedge Emissions Plots as an attachment.

**HARMONIC AND SPURIOUS RADIATED EMISSIONS (2.4 GHZ BAND)**

See Client's Harmonic, Spurious, & Bandedge Emissions Plots as an attachment.

DIGITAL DEVICE RADIATED EMISSIONS

See Client's Radiated Emissions Plot as an attachment.

## **8.7. POWERLINE CONDUCTED EMISSIONS**

### **TEST SETUP**

The EUT is placed on a wooden table 40 cm from the vertical ground plane and 80 cm above the horizontal ground plane on the floor.

The EUT is set to transmit in a continuous mode.

### **TEST PROCEDURE**

The resolution bandwidth is set to 10 kHz for both peak detection and quasi-peak detection measurements. Peak detection is used unless otherwise noted as quasi-peak.

Line conducted data is recorded for both NEUTRAL and HOT lines.

### **RESULTS**

See Client's Powerline Conducted Emission Plots as an attachment.

No non-compliance noted:

## 8.8. SETUP PHOTOS

### ANTENNA PORT CONDUCTED RF MEASUREMENT SETUP



**RADIATED RF MEASUREMENT SETUP**

See Client's Setup Photos as an attachment.



**DIGITAL DEVICE RADIATED EMISSIONS MEASUREMENT SETUP**

See Client's Setup Photos as an attachment.

**POWERLINE CONDUCTED EMISSIONS MEASUREMENT SETUP**

See Client's Setup Photos as an attachment.

**END OF REPORT**

Page 42 of 42