

TEST REPORT

Report Number: 14982489-E18V4

Applicant : APPLE, INC
1 APPLE PARK WAY
CUPERTINO, CA 95014, U.S.A.

Model : A3082

Brand : APPLE

FCC ID : BCG-E8692A

EUT Description : SMARTPHONE

Test Standard(s) : FCC 47 CFR PART 2, PART 22, PART 24, PART 27,
AND PART 90

Date Of Issue:
2024-08-27

Prepared by:
UL Verification Services Inc.
47173 Benicia Street
Fremont, CA 94538, U.S.A.
TEL: (510) 319-4000
FAX: (510) 661-0888



Revision History

<u>Rev.</u>	<u>Issue Date</u>	<u>Revisions</u>	<u>Revised By</u>
V1	2024-08-14	Initial Review	Mengistu Mekuria
V2	2024-08-22	Updated Section 6, 9 &10	Binod Sitaula
V3	2024-08-23	Updated Section 6.2 and 9.3.4	Binod Sitaula
V4	2024-08-27	Addressed TCB Questions at Section 9.5.	Mengistu Mekuria

TABLE OF CONTENTS

1. ATTESTATION OF TEST RESULTS	8
2. SUMMARY OF TEST RESULTS	9
3. TEST METHODOLOGY	11
4. FACILITIES AND ACCREDITATION	11
5. DECISION RULES AND MEASUREMENT UNCERTAINTY	12
5.1. METROLOGICAL TRACEABILITY	12
5.2. DECISION RULES	12
5.3. MEASUREMENT UNCERTAINTY	12
5.4. SAMPLE CALCULATION	12
6. EQUIPMENT UNDER TEST	13
6.1. DESCRIPTION OF EUT	13
6.2. MAXIMUM OUTPUT POWER	13
6.3. SOFTWARE AND FIRMWARE	25
6.4. MAXIMUM ANTENNA GAIN	25
6.5. WORST-CASE CONFIGURATION AND MODE	26
6.6. DESCRIPTION OF TEST SETUP	28
7. TEST AND MEASUREMENT EQUIPMENT	30
8. RF OUTPUT POWER MEASUREMENTS	31
8.1. LTE BAND 7 AND 5G NR n7	32
8.2. LTE BAND 12 AND 5G NR n12	38
8.3. LTE BAND 13	42
8.4. LTE BAND 14 AND 5G NR n14	43
8.5. LTE BAND 17	45
8.6. LTE BAND 25 AND 5G NR n25	46
8.7. LTE BAND 26 AND 5G NR n26 (FCC Part 90S)	53
8.8. LTE BAND 26 AND 5G NR n26 (FCC Part 22)	56
8.9. LTE BAND 30 AND 5G NR n30	60
8.10. LTE BAND 41 AND 5G NR n41	62
8.11. LTE BAND 66 AND 5G NR n66	70
8.12. 5G NR n70	77
8.13. LTE BAND 71 AND 5G NR n71	79

8.14. 5G NR n77 (FCC Part 27 3450-3550MHz) 83

8.15. 5G NR n77 (FCC Part 27 3700-3980MHz) 89

9. CONDUCTED TEST RESULTS 95

9.1. OCCUPIED BANDWIDTH 95

9.1.1. LTE BAND 7 AND 5G NR n7..... 107

9.1.2. LTE BAND 12 AND 5G NR n12..... 110

9.1.3. LTE BAND 13..... 112

9.1.4. LTE BAND 14 AND 5G NR n14..... 113

9.1.5. LTE BAND 17..... 115

9.1.6. LTE BAND 25 AND 5G NR n25..... 116

9.1.7. LTE BAND 26 AND 5G NR n26 (FCC PART 90S) 120

9.1.8. LTE BAND 26 AND 5G NR n26 (FCC PART 22)..... 122

9.1.9. LTE BAND 30 AND 5G NR n30..... 124

9.1.10. LTE BAND 41 AND 5G NR n41 126

9.1.11. LTE BAND 66 AND 5G NR n66 129

9.1.12. 5G NR n70..... 133

9.1.13. LTE BAND 71 AND 5G NR n71 134

9.1.14. 5G NR n77 (FCC Part 27 3450-3550MHz)..... 136

9.1.15. 5G NR n77 (FCC Part 27 3700-3980MHz)..... 138

9.2. EMISSION MASK AND ADJACENT CHANNEL POWER..... 140

9.2.1. LTE BAND 7 AND 5G NR n7..... 142

9.2.2. LTE BAND 12 AND 5G NR n12..... 161

9.2.3. LTE BAND 13..... 173

9.2.4. LTE BAND 14 AND 5G NR n14..... 176

9.2.5. LTE BAND 17..... 181

9.2.6. LTE BAND 25 AND 5G NR n25..... 184

9.2.7. LTE BAND 26 AND 5G NR n26 (FCC PART 90S) 195

9.2.8. LTE BAND 26 AND 5G NR n26 (FCC PART 22)..... 201

9.2.9. LTE BAND 30 AND 5G NR n30..... 207

9.2.10. LTE BAND 41 AND 5G NR n41 214

9.2.11. LTE BAND 66 AND 5G NR n66 238

9.2.12. 5G NR n70..... 249

9.2.13. LTE BAND 71 AND 5G NR n71 253

9.2.14. 5G NR n77 (FCC Part 27 3450-3550MHz)..... 266

9.2.15. 5G NR n77 (FCC Part 27 3700-3980MHz)..... 283

9.3. OUT OF BAND EMISSIONS 301

- 9.3.1. LTE BAND 7 AND 5G NR n7..... 302
- 9.3.2. LTE BAND 12 AND 5G NR n12..... 304
- 9.3.3. LTE BAND 13..... 306
- 9.3.4. LTE BAND 14 AND 5G NR n14..... 308
- 9.3.5. LTE BAND 17..... 311
- 9.3.6. LTE BAND 25 AND 5G NR n25..... 312
- 9.3.7. LTE BAND 26 AND 5G NR n26(FCC PART 90S) 314
- 9.3.8. LTE BAND 26 AND 5G NR n26 (FCC PART 22)..... 316
- 9.3.9. LTE BAND 30 AND 5G NR n30..... 318
- 9.3.10. LTE BAND 41 AND 5G NR n41 320
- 9.3.11. LTE BAND 66 AND 5G NR n66 322
- 9.3.12. 5G NR n70..... 324
- 9.3.13. LTE BAND 71 AND 5G NR n71 325
- 9.3.14. 5G NR n77 (FCC Part 27 3450-3550MHz)..... 327
- 9.3.15. 5G NR n77 (FCC Part 27 3700-3980MHz)..... 328

9.4. FREQUENCY STABILITY 329

- 9.4.1. LTE BAND 7 AND 5G NR n7..... 330
- 9.4.2. LTE BAND 12 AND 5G NR n12..... 332
- 9.4.3. LTE BAND 13..... 334
- 9.4.4. LTE BAND 14 AND 5G NR n14..... 335
- 9.4.5. LTE BAND 17..... 337
- 9.4.6. LTE BAND 25 AND 5G NR n25..... 338
- 9.4.7. LTE BAND 26 AND 5G NR n26(FCC PART 90S) 340
- 9.4.8. LTE BAND 26 AND 5G NR n26(FCC PART 22)..... 342
- 9.4.9. LTE BAND 30 AND 5G NR n30..... 344
- 9.4.10. LTE BAND 41 AND 5G NR n41 346
- 9.4.11. LTE BAND 66 AND 5G NR n66 348
- 9.4.12. 5G NR n70..... 350
- 9.4.13. LTE BAND 71 AND 5G NR n71 351
- 9.4.14. 5G NR n77 (FCC Part 27 3450-3550MHz)..... 353
- 9.4.15. 5G NR n77 (FCC Part 27 3700-3980MHz)..... 354

9.5. PEAK-TO-AVERAGE POWER RATIO 355

- 9.5.1. LTE BAND 7 AND 5G NR n7..... 356
- 9.5.2. LTE BAND 12 AND 5G NR n12..... 357

9.5.3. LTE BAND 13..... 357

9.5.4. LTE BAND 14 AND 5G NR n14..... 357

9.5.5. LTE BAND 17..... 358

9.5.6. LTE BAND 25 AND 5G NR n25..... 358

9.5.7. LTE BAND 26 AND 5G NR n26 (FCC PART 90S) 359

9.5.8. LTE BAND 26 AND 5G NR n26 (FCC PART 22)..... 359

9.5.9. LTE BAND 30 AND 5G NR N30 360

9.5.10. LTE BAND 41 AND 5G NR n41 360

9.5.11. LTE BAND 66 AND 5G NR n66 361

9.5.12. 5G NR n70..... 361

9.5.13. LTE BAND 71 AND 5G NR n71 362

9.5.14. 5G NR n77 (FCC Part 27 3450-3550MHz)..... 362

9.5.15. 5G NR n77 (FCC Part 27 3700-3980MHz)..... 363

10. RADIATED TEST RESULTS..... 364

10.1. FIELD STRENGTH OF SPURIOUS RADIATION, ANT1 367

10.1.1. LTE BAND 7 AND 5G NR n7 368

10.1.2. LTE BAND 12 AND 5G NR n12 371

10.1.3. LTE BAND 13 374

10.1.4. LTE BAND 14 AND 5G NR n14 376

10.1.5. LTE BAND 17 379

10.1.6. LTE BAND 25 AND 5G NR n25 381

10.1.7. LTE BAND 26 (FCC PART 90S)..... 384

10.1.8. LTE BAND 26 AND 5G NR n26 (FCC PART 22) 386

10.1.9. LTE BAND 30 AND 5G NR n30 389

10.1.10. LTE BAND 41 AND 5G NR n41 391

10.1.11. LTE BAND 66 AND 5G NR n66 393

10.1.12. 5G NR n70..... 396

10.1.13. LTE BAND 71 AND 5G NR n71 397

10.2. FIELD STRENGTH OF SPURIOUS RADIATION, ANT2 400

10.2.1. LTE BAND 7 AND 5G NR n7 401

10.2.2. LTE BAND 12 AND 5G NR n12 404

10.2.3. LTE BAND 13 407

10.2.4. LTE BAND 14 AND 5G NR n14 409

10.2.5. LTE BAND 17 412

10.2.6. LTE BAND 25 AND 5G NR n25 414

10.2.7.	LTE BAND 26 (FCC PART 90S).....	416
10.2.8.	LTE BAND 26 AND 5G NR n26 (FCC PART 22).....	419
10.2.9.	LTE BAND 30 AND 5G NR n30.....	422
10.2.10.	LTE BAND 41 AND 5G NR n41.....	424
10.2.11.	LTE BAND 66 AND 5G NR n66.....	427
10.2.12.	5G NR n70.....	430
10.2.13.	LTE BAND 71 AND 5G NR n71.....	431
10.3.	FIELD STRENGTH OF SPURIOUS RADIATION, ANT3.....	434
10.3.1.	LTE BAND 7 AND 5G NR n7.....	435
10.3.2.	LTE BAND 25 AND 5G NR n25.....	438
10.3.3.	LTE BAND 30 AND 5G NR n30.....	441
10.3.4.	LTE BAND 41 AND 5G NR n41.....	444
10.3.5.	LTE BAND 66 AND 5G NR n66.....	447
10.3.6.	5G NR n70.....	450
10.4.	FIELD STRENGTH OF SPURIOUS RADIATION, ANT4.....	451
10.4.1.	LTE BAND 7 AND 5G NR n7.....	452
10.4.2.	LTE BAND 25 AND 5G NR n25.....	455
10.4.3.	LTE BAND 30 AND 5G NR n30.....	458
10.4.4.	LTE BAND 41 AND 5G NR n41.....	461
10.4.5.	LTE BAND 66 AND 5G NR n66.....	464
10.4.6.	5G NR n70.....	467
10.4.7.	5G NR n77 (FCC Part 27 3450-3550MHz).....	468
10.4.8.	5G NR n77 (FCC Part 27 3700-3980MHz).....	469
10.5.	FIELD STRENGTH OF SPURIOUS RADIATION, ANT 7.....	471
10.5.1.	5G NR n77 (FCC Part 27 3450-3550MHz).....	472
10.5.2.	5G NR n77 (FCC Part 27 3700-3980MHz).....	473
10.6.	FIELD STRENGTH OF SPURIOUS RADIATION, ANT 8.....	475
10.6.1.	5G NR n77 (FCC Part 27 3450-3550MHz).....	476
10.6.2.	5G NR n77 (FCC Part 27 3700-3980MHz).....	477
10.7.	FIELD STRENGTH OF SPURIOUS RADIATION, ANT9.....	479
10.7.1.	5G NR n77 (FCC Part 27 3450-3550MHz).....	479
10.7.2.	5G NR n77 (FCC Part 27 3700-3980MHz).....	480
11.	SETUP PHOTOS.....	482



1. ATTESTATION OF TEST RESULTS

Applicant Name and Address	APPLE, INC 1 APPLE PARK WAY CUPERTINO, CA 95014, U.S.A.
Model	A3082
Brand	APPLE
FCC ID	BCG-E8692A
EUT Description	SMARTPHONE
Serial Number	Radiated: HJWN3127DQ, THVY70QKM3 Conducted: C7HH28000240000HBR, C7HH57000DM0000HBU, C7HH6000590000HBR
Sample Receipt Date	2024-02-02
Date Tested	2024-02-02 to 2024-07-30
Applicable Standards	FCC 47 CFR Part 2, Part 22, Part 24, Part 27, and Part 90
Test Results	COMPLIES

UL Verification Services Inc. tested the above equipment in accordance with the requirements set forth in the above standards. The test results show that the equipment tested is capable of demonstrating compliance with the requirements as documented in this report.

The results documented in this report apply only to the tested sample, under the conditions and modes of operation as described herein. It is the manufacturer's responsibility to assure that additional production units of this model are manufactured with identical electrical and mechanical components. All samples tested were in good operating condition throughout the entire test program. Measurement Uncertainties are published for informational purposes only and were not taken into account unless noted otherwise.

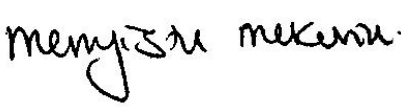
This document may not be altered or revised in any way unless done so by UL Verification Services Inc. and all revisions are duly noted in the revisions section. Any alteration of this document not carried out by UL Verification Services Inc. will constitute fraud and shall nullify the document.

Approved & Released By:	Reviewed By:	Prepared By:
		
Mengistu Mekuria Staff Laboratory Engineer UL Verification Services Inc.	Binod Sitaula Laboratory Engineer Associate UL Verification Services Inc.	Tewodros Woldemichael Project Engineer UL Verification Services Inc.

2. SUMMARY OF TEST RESULTS

This report contains data provided by the customer which can impact the validity of results. UL Verification Services Inc. is only responsible for correctly integrating customer-provided data with measurements performed by UL Verification Services Inc.

Below is a list of the data provided by the customer:

1. Antenna gain (see section 6.4)

Requirement Description	Band	Requirement Clause Number (FCC)	Result	Remarks
RF Conducted Output Power	26 (90S)	2.1046, 90.635 (b)	Complies	
Effective Radiated Power	5, 26	22.913 (a)(5)	Complies	
	12	27.50 (c) (10)	Complies	
	13	27.50 (b) (10)	Complies	
	14	90.541 (d)	Complies	
	17	27.50 (c) (10)	Complies	
Equivalent Isotropic Radiated Power	71	27.50 (c) (10)	Complies	
	2, 25	24.232 (c)	Complies	
	4, 66	27.50 (d) (4)	Complies	
	70	27.50 (d) (4)	Complies	
	30	27.50 (a) (3)	Complies	
	7, 41, 38	27.50 (h) (2)	Complies	
	77	27.50 (j) (3), (k) (3)	Complies	

Requirement Description	Requirement Clause Number (FCC)	Result	Remarks
Occupied Bandwidth	2.1049	Complies	
Band Edge and Emission Mask	2.1051, 22.917 (a), 24.238 (a), 27.53 (h), 27.53 (m)(4) & (m) (6), 27.53 (g), 27.53 (c) (f), 27.53(a), 27.53(l), 90.543 (e)(f), 90.691 (a)	Complies	
Out of Band Emissions	2.1051, 22.917 (a), 24.238 (a), 27.53 (h), 27.53 (m)(4) & (m) (6), 27.53 (g), 27.53 (c) (f), 27.53(a), 27.53(l), 90.543 (e)(f), 90.691 (a)	Complies	
Frequency Stability	2.1055, 22.355, 24.235, 27.54, 90.539, 90.213	Complies	
Peak-to-Average Ratio	22.913 (d), 24.232 (d), 27.50 (d) (5), 27.50 (j) (4)	Complies	
Field Strength of Spurious Radiation	2.1053, 22.917 (a), 24.238 (a), 27.53 (h), 27.53 (m)(4) & (m) (6), 27.53 (g), 27.53 (c) (f), 27.53(a), 27.53(l), 90.543 (e)(f), 90.691 (a)	Complies	

3. TEST METHODOLOGY

The tests documented in this report were performed in accordance with the following:

- ANSI C63.26:2015
- FCC 47 CFR Part 2, Part 22, Part 24, Part 27, and Part 90
- [FCC KDB 971168 D01](#) : Power Meas License Digital Systems
- [FCC KDB 971168 D02](#): Misc Rev Approv License Devices
- [FCC KDB 412172 D01](#) : Determining ERP and EIRP

4. FACILITIES AND ACCREDITATION

UL Verification Services Inc. is accredited by A2LA, certification #0751.05, for all testing performed within the scope of this report. Testing was performed at the locations noted below.

	Address	ISED CABID	ISED Company Number	FCC Registration
<input checked="" type="checkbox"/>	Building 1: 47173 Benicia Street, Fremont, CA 94538, USA	US0104	2324A	550739
<input checked="" type="checkbox"/>	Building 2: 47266 Benicia Street, Fremont, CA 94538, USA			
<input type="checkbox"/>	Building 3: 843 Auburn Court, Fremont, CA 94538 USA			
<input checked="" type="checkbox"/>	Building 4: 47658 Kato Rd, Fremont, CA 94538, USA			
<input checked="" type="checkbox"/>	Building 5: 47670 Kato Rd, Fremont, CA 94538 USA			

5. DECISION RULES AND MEASUREMENT UNCERTAINTY

5.1. METROLOGICAL TRACEABILITY

All test and measuring equipment utilized to perform the tests documented in this report are calibrated on a regular basis, with a maximum time between calibrations of one year or the manufacturers' recommendation, whichever is less, and where applicable is traceable to recognized national standards.

5.2. DECISION RULES

The Decision Rule is based on Simple Acceptance in accordance with ISO Guide 98-4:2012 Clause 8.2. (Measurement uncertainty is not taken into account when stating conformity with a specified requirement.)

5.3. MEASUREMENT UNCERTAINTY

Where relevant, the following measurement uncertainty levels have been estimated for tests performed on the apparatus:

PARAMETER	U _{Lab}
Conducted Antenna Port Emission Measurement	1.940 db
Power Spectral Density	2.466 db
Time Domain Measurements Using SA	3.39 %
RF Power Measurement Direct Method Using Power Meter	0.450 db Peak 1.300 db Ave.
Radio Frequency (Spectrum Analyzer)	141.16 Hz
Occupied Bandwidth	1.22%
Worst Case Conducted Disturbance, 9KHz to 0.15 MHz	3.78 db
Worst Case Conducted Disturbance, 0.15 to 30 MHz	3.40 db
Worst Case Radiated Disturbance, 9KHz to 30 MHz	2.87 db
Worst Case Radiated Disturbance, 30 to 1000 MHz	6.01 db
Worst Case Radiated Disturbance, 1000 to 18000 MHz	4.73 db
Worst Case Radiated Disturbance, 18000 to 26000 MHz	4.51 db
Worst Case Radiated Disturbance, 26000 to 40000 MHz	5.29 db

Uncertainty figures are valid to a confidence level of 95%.

5.4. SAMPLE CALCULATION

RADIATED EMISSIONS

Where relevant, the following sample calculation is provided:

$$\text{Field Strength (dBuV/m)} = \text{Measured Voltage (dBuV)} + \text{Antenna Factor (dB/m)} + \text{Cable Loss (dB)} - \text{Preamp Gain (dB)}$$

$$36.5 \text{ dBuV} + 18.7 \text{ dB/m} + 0.6 \text{ dB} - 26.9 \text{ dB} = 28.9 \text{ dBuV/m}$$

6. EQUIPMENT UNDER TEST

6.1. DESCRIPTION OF EUT

The Apple iPhone is a smartphone with cellular GSM, GPRS, EGPRS, WCDMA, LTE, 5G NR1, 5G NR2, IEEE 802.11a/b/g/n/ac/ax/be, Bluetooth (BT), Ultra-Wideband (UWB), Global Positioning System (GPS), Near-Field Communication (NFC), Narrow-Band (NB) UNII, 802.15.4, 802.15.4ab-Narrow Band (NB) and Mobile Satellite Service (MSS) technologies. The rechargeable battery is not user accessible. This device is not user-serviceable and requires special tools to disassemble.

6.2. MAXIMUM OUTPUT POWER

EIRP/ERP TEST PROCEDURE

ANSI C63.26:2015
KDB 971168 D01 Section 5.6

$$\text{ERP/EIRP} = \text{PMeas} + \text{GT} - \text{LC}$$

where: ERP/EIRP = effective or equivalent radiated power, respectively (expressed in the same units as PMeas, typically dBW or dBm);

PMeas = measured transmitter output power or PSD, in dBm or dBW;

GT = gain of the transmitting antenna, in dBd (ERP) or dBi (EIRP);

LC = signal attenuation in the connecting cable between the transmitter and antenna, in dB.

For devices utilizing multiple antennas, KDB 662911 provides guidance for determining the effective array transmit antenna gain term to be used in the above equation.

The transmitter has a maximum average conducted and ERP / EIRP output powers as follows:

LTE BAND 7

Part 27								
EIRP Limit (W)		2.00						
Antenna Gain (dBi)_Ant(3)		0.30						
Bandwidth (MHz)	Modulation	Low Frequency (MHz)	Upper Frequency (MHz)	Conducted Average (dBm)	EIRP Average (dBm)	EIRP Average (W)	99% BW (kHz)	Emission Designator
5.0	QPSK	2502.5	2567.5	25.00	25.30	0.339	4505	4M51G7W
	16QAM			24.49	24.79	0.301	4504	4M50D7W
10.0	QPSK	2505.0	2565.0	25.00	25.30	0.339	8992	8M99G7W
	16QAM			24.48	24.78	0.301	9003	9M00D7W
15.0	QPSK	2507.5	2562.5	25.00	25.30	0.339	13454	13M5G7W
	16QAM			24.48	24.78	0.301	13436	13M4D7W
20.0	QPSK	2510.0	2560.0	25.00	25.30	0.339	17869	17M9G7W
	16QAM			24.61	24.91	0.310	17924	17M9D7W

5G NR n7

Part 27								
EIRP Limit (W)		2.00						
Antenna Gain (dBi)_Ant(3)		0.30						
Bandwidth (MHz)	Modulation	Low Frequency (MHz)	Upper Frequency (MHz)	Conducted Average (dBm)	EIRP Average (dBm)	EIRP Average (W)	99% BW (kHz)	Emission Designator
5.0	BPSK	2502.5	2567.5	24.96	25.26	0.336	4494	4M49G7W
	QPSK			25.00	25.30	0.339	4476	4M48G7W
	16QAM			25.00	25.30	0.339	4480	4M48D7W
10.0	BPSK	2505.0	2565.0	24.91	25.21	0.332	8976	8M98G7W
	QPSK			25.00	25.30	0.339	8978	8M98G7W
	16QAM			24.89	25.19	0.330	8971	8M97D7W
15.0	BPSK	2507.5	2562.5	24.88	25.18	0.330	13400	13M4G7W
	QPSK			25.00	25.30	0.339	13433	13M4G7W
	16QAM			24.76	25.06	0.321	13395	13M4D7W
20.0	BPSK	2510.0	2560.0	25.00	25.30	0.339	17922	17M9G7W
	QPSK			24.94	25.24	0.334	17883	17M9G7W
	16QAM			24.87	25.17	0.329	17897	17M9D7W
25.0	BPSK	2512.5	2557.5	25.00	25.30	0.339	22927	22M9G7W
	QPSK			24.99	25.29	0.338	22978	23M0G7W
	16QAM			24.73	25.03	0.318	22923	22M9D7W
30.0	BPSK	2515.0	2555.0	24.95	25.25	0.335	28627	28M6G7W
	QPSK			25.00	25.30	0.339	28534	28M5G7W
	16QAM			24.82	25.12	0.325	28597	28M6D7W
35.0	BPSK	2517.5	2552.5	24.98	25.28	0.337	32112	32M1G7W
	QPSK			25.00	25.30	0.339	32089	32M1G7W
	16QAM			25.00	25.30	0.339	32190	32M2D7W
40.0	BPSK	2520.0	2550.0	24.91	25.21	0.332	38609	38M6G7W
	QPSK			25.00	25.30	0.339	38588	38M6G7W
	16QAM			24.92	25.22	0.333	38480	38M5D7W

LTE BAND 12

Part 27								
ERP Limit (W)		3.00						
Antenna Gain (dBi)_Ant(1)		-4.40						
Bandwidth (MHz)	Modulation	Low Frequency (MHz)	Upper Frequency (MHz)	Conducted Average (dBm)	ERP Average (dBm)	ERP Average (W)	99% BW (kHz)	Emission Designator
1.4	QPSK	699.7	715.3	25.70	19.15	0.082	1094	1M09G7W
	16QAM			25.46	18.91	0.078	1095	1M10D7W
3.0	QPSK	700.5	714.5	25.70	19.15	0.082	2701	2M70G7W
	16QAM			25.45	18.90	0.078	2705	2M71D7W
5.0	QPSK	701.5	713.5	25.70	19.15	0.082	4501	4M50G7W
	16QAM			25.40	18.85	0.077	4496	4M50D7W
10.0	QPSK	704.0	711.0	25.70	19.15	0.082	8969	8M97G7W
	16QAM			25.49	18.94	0.078	8975	8M98D7W

5G NR n12

Part 27								
ERP Limit (W)		3.00						
Antenna Gain (dBi)_Ant(1)		-4.40						
Bandwidth (MHz)	Modulation	Low Frequency (MHz)	Upper Frequency (MHz)	Conducted Average (dBm)	ERP Average (dBm)	ERP Average (W)	99% BW (kHz)	Emission Designator
5.0	BPSK	701.5	713.5	25.70	19.15	0.082	4502	4M50G7W
	QPSK			25.66	19.11	0.081	4457	4M46G7W
	16QAM			25.28	18.73	0.075	4486	4M49D7W
10.0	BPSK	704.0	711.0	25.69	19.14	0.082	8940	8M94G7W
	QPSK			25.70	19.15	0.082	8955	8M96G7W
	16QAM			25.38	18.83	0.076	8924	8M92D7W
15.0	BPSK	706.5	708.5	25.63	19.08	0.081	13415	13M4G7W
	QPSK			25.70	19.15	0.082	13337	13M3G7W
	16QAM			25.25	18.70	0.074	13432	13M4D7W

LTE BAND 13

Part 27								
ERP Limit (W)		3.00						
Antenna Gain (dBi)_Ant(1)		-5.10						
Bandwidth (MHz)	Modulation	Low Frequency (MHz)	Upper Frequency (MHz)	Conducted Average (dBm)	ERP Average (dBm)	ERP Average (W)	99% BW (kHz)	Emission Designator
5.0	QPSK	779.5	784.5	25.70	18.45	0.070	4507	4M51G7W
	16QAM			25.47	18.22	0.066	4504	4M50D7W
10.0	QPSK	782.0	782.0	25.70	18.45	0.070	8983	8M98G7W
	16QAM			25.50	18.25	0.067	8976	8M98D7W

LTE BAND 14

Part 90R								
ERP Limit (W)		3.00						
Antenna Gain (dBi)_Ant(1)		-5.10						
Bandwidth (MHz)	Modulation	Low Frequency (MHz)	Upper Frequency (MHz)	Conducted Average (dBm)	ERP Average (dBm)	ERP Average (W)	99% BW (kHz)	Emission Designator
5.0	QPSK	790.5	795.5	25.70	18.45	0.070	4507	4M51G7W
	16QAM			24.95	17.70	0.059	4501	4M50D7W
10.0	QPSK	793.0	793.0	25.70	18.45	0.070	8976	8M98G7W
	16QAM			24.98	17.73	0.059	8953	8M95D7W

5G NR n14

Part 90R								
ERP Limit (W)		3.00						
Antenna Gain (dBi)_Ant(1)		-5.10						
Bandwidth (MHz)	Modulation	Low Frequency (MHz)	Upper Frequency (MHz)	Conducted Average (dBm)	ERP Average (dBm)	ERP Average (W)	99% BW (kHz)	Emission Designator
5.0	BPSK	790.5	795.5	25.70	18.45	0.070	4487	4M49G7W
	QPSK			25.68	18.43	0.070	4492	4M49G7W
	16QAM			25.12	17.87	0.061	4476	4M48D7W
10.0	BPSK	793.0	793.0	25.70	18.45	0.070	8960	8M96G7W
	QPSK			25.65	18.40	0.069	8933	8M93G7W
	16QAM			25.61	18.36	0.069	8920	8M92D7W

LTE BAND 17

Part 27								
ERP Limit (W)		3.00						
Antenna Gain (dBi)_Ant(1)		-4.40						
Bandwidth (MHz)	Modulation	Low Frequency (MHz)	Upper Frequency (MHz)	Conducted Average (dBm)	ERP Average (dBm)	ERP Average (W)	99% BW (kHz)	Emission Designator
5.0	QPSK	706.5	713.5	25.70	19.15	0.082	4495	4M50G7W
	16QAM			25.39	18.84	0.077	4500	4M50D7W
10.0	QPSK	709.0	711.0	25.70	19.15	0.082	8966	8M97G7W
	16QAM			25.46	18.91	0.078	8968	8M97D7W

LTE BAND 25

Part 24								
EIRP Limit (W)		2.00						
Antenna Gain (dBi)_Ant(3)		-0.60						
Bandwidth (MHz)	Modulation	Low Frequency (MHz)	Upper Frequency (MHz)	Conducted Average (dBm)	EIRP Average (dBm)	EIRP Average (W)	99% BW (kHz)	Emission Designator
1.4	QPSK	1850.7	1914.3	25.50	24.90	0.309	1095	1M10G7W
	16QAM			25.07	24.47	0.280	1095	1M10D7W
3.0	QPSK	1851.5	1913.5	25.50	24.90	0.309	2702	2M70G7W
	16QAM			25.01	24.41	0.276	2708	2M71D7W
5.0	QPSK	1852.5	1912.5	25.50	24.90	0.309	4509	4M51G7W
	16QAM			25.03	24.43	0.277	4504	4M50D7W
10.0	QPSK	1855.0	1910.0	25.50	24.90	0.309	8986	8M99G7W
	16QAM			25.06	24.46	0.279	8994	8M99D7W
15.0	QPSK	1857.5	1907.5	25.50	24.90	0.309	13475	13M5G7W
	16QAM			25.04	24.44	0.278	13487	13M5D7W
20.0	QPSK	1860.0	1905.0	25.50	24.90	0.309	17937	17M9G7W
	16QAM			25.10	24.50	0.282	17947	17M9D7W

5G NR n25

Part 24								
EIRP Limit (W)		2.00						
Antenna Gain (dBi)_Ant(3)		-0.60						
Bandwidth (MHz)	Modulation	Low Frequency (MHz)	Upper Frequency (MHz)	Conducted Average (dBm)	EIRP Average (dBm)	EIRP Average (W)	99% BW (kHz)	Emission Designator
5.0	BPSK	1852.5	1912.5	25.50	24.90	0.309	4492	4M49G7W
	QPSK			25.46	24.86	0.306	4482	4M48G7W
	16QAM			25.02	24.42	0.277	4497	4M50D7W
10.0	BPSK	1855.0	1910.0	25.43	24.83	0.304	8962	8M96G7W
	QPSK			25.50	24.90	0.309	8983	8M98G7W
	16QAM			25.19	24.59	0.288	8934	8M93D7W
15.0	BPSK	1857.5	1907.5	25.50	24.90	0.309	13427	13M4G7W
	QPSK			25.44	24.84	0.305	13417	13M4G7W
	16QAM			25.15	24.55	0.285	13462	13M5D7W
20.0	BPSK	1860.0	1905.0	25.50	24.90	0.309	17881	17M9G7W
	QPSK			25.47	24.87	0.307	17879	17M9G7W
	16QAM			25.21	24.61	0.289	17874	17M9D7W
25.0	BPSK	1862.5	1902.5	25.50	24.90	0.309	22911	22M9G7W
	QPSK			25.46	24.86	0.306	22962	23M0G7W
	16QAM			25.04	24.44	0.278	22872	22M9D7W
30.0	BPSK	1865.0	1900.0	25.50	24.90	0.309	28650	28M7G7W
	QPSK			25.43	24.83	0.304	28573	28M6G7W
	16QAM			25.06	24.46	0.279	28591	28M6D7W
35.0	BPSK	1867.5	1897.5	25.45	24.85	0.305	32252	32M3G7W
	QPSK			25.50	24.90	0.309	32216	32M2G7W
	16QAM			25.12	24.52	0.283	32143	32M1D7W
40.0	BPSK	1870.0	1895.0	25.44	24.84	0.305	38548	38M5G7W
	QPSK			25.50	24.90	0.309	38578	38M6G7W
	16QAM			24.85	24.25	0.266	38625	38M6D7W

LTE BAND 26 (FCC Part 90S)

Part 90S									
Conducted Limit (W)		100.00							
Antenna Gain (dBi)_Ant(1)		-5.10							
Bandwidth (MHz)	Modulation	Low Frequency (MHz)	Upper Frequency (MHz)	Conducted Average (dBm)	Conducted Average (W)	ERP Average (dBm)	ERP Average (W)	99% BW (kHz)	Emission Designator
1.4	QPSK	814.7	823.3	25.70	0.37	18.45	0.070	1092	1M09G7W
	16QAM			25.42	0.35	18.17	0.066	1098	1M10D7W
3.0	QPSK	815.5	822.5	25.70	0.37	18.45	0.070	2703	2M70G7W
	16QAM			25.46	0.35	18.21	0.066	2711	2M71D7W
5.0	QPSK	816.5	821.5	25.70	0.37	18.45	0.070	4510	4M51G7W
	16QAM			25.50	0.35	18.25	0.067	4512	4M51D7W
10.0	QPSK	819.0	819.0	25.70	0.37	18.45	0.070	8974	8M97G7W
	16QAM			25.53	0.36	18.28	0.067	8982	8M98D7W

5G NR n26 (FCC Part 90S)

Part 90S									
Conducted Limit (W)		100.00							
Antenna Gain (dBi)_Ant(1)		-5.10							
Bandwidth (MHz)	Modulation	Low Frequency (MHz)	Upper Frequency (MHz)	Conducted Average (dBm)	Conducted Average (W)	ERP Average (dBm)	ERP Average (W)	99% BW (kHz)	Emission Designator
5.0	BPSK	816.5	821.5	25.70	0.37	18.45	0.070	4467	4M47G7W
	QPSK			25.69	0.37	18.44	0.070	4485	4M49G7W
	16QAM			25.28	0.34	18.03	0.064	4491	4M49D7W
10.0	BPSK	819.0	819.0	25.70	0.37	18.45	0.070	8989	8M99G7W
	QPSK			25.59	0.36	18.34	0.068	8969	8M97G7W
	16QAM			24.93	0.31	17.68	0.059	8948	8M95D7W

LTE BAND 26 (FCC Part 22)

Part 22									
ERP Limit (W)		7.00							
Antenna Gain (dBi)_Ant(1)		-5.10							
Bandwidth (MHz)	Modulation	Low Frequency (MHz)	Upper Frequency (MHz)	Conducted Average (dBm)	ERP Average (dBm)	ERP Average (W)	99% BW (kHz)	Emission Designator	
1.4	QPSK	824.7	848.3	25.70	18.45	0.070	1095	1M10G7W	
	16QAM			25.36	18.11	0.065	1096	1M10D7W	
3.0	QPSK	825.5	847.5	25.70	18.45	0.070	2702	2M70G7W	
	16QAM			25.55	18.30	0.068	2705	2M71D7W	
5.0	QPSK	826.5	846.5	25.70	18.45	0.070	4500	4M50G7W	
	16QAM			25.46	18.21	0.066	4502	4M50D7W	
10.0	QPSK	829.0	844.0	25.70	18.45	0.070	8988	8M99G7W	
	16QAM			25.47	18.22	0.066	8975	8M98D7W	

5G NR n26 (FCC Part 22)

Part 22								
ERP Limit (W)		7.00						
Antenna Gain (dBi)_Ant(1)		-5.10						
Bandwidth (MHz)	Modulation	Low Frequency (MHz)	Upper Frequency (MHz)	Conducted Average (dBm)	ERP Average (dBm)	ERP Average (W)	99% BW (kHz)	Emission Designator
5.0	BPSK	826.5	846.5	25.64	18.39	0.069	4456	4M46G7W
	QPSK			25.70	18.45	0.070	4483	4M48G7W
	16QAM			25.35	18.10	0.065	4472	4M47D7W
10.0	BPSK	829.0	844.0	25.70	18.45	0.070	8939	8M94G7W
	QPSK			25.61	18.36	0.069	8981	8M98G7W
	16QAM			25.52	18.27	0.067	8972	8M97D7W
15.0	BPSK	831.5	841.5	25.70	18.45	0.070	13396	13M4G7W
	QPSK			25.62	18.37	0.069	13421	13M4G7W
	16QAM			25.37	18.12	0.065	13395	13M4D7W
20.0	BPSK	834.0	839.0	25.70	18.45	0.070	17844	17M8G7W
	QPSK			25.70	18.45	0.070	17894	17M9G7W
	16QAM			25.29	18.04	0.064	17860	17M9D7W

LTE BAND 30

Part 27								
EIRP Limit (W)		0.25						
Antenna Gain (dBi)_Ant(3)		0.30						
Bandwidth (MHz)	Modulation	Low Frequency (MHz)	Upper Frequency (MHz)	Conducted Average (dBm)	EIRP Average (dBm)	EIRP Average (W)	99% BW (kHz)	Emission Designator
5.0	QPSK	2307.5	2312.5	23.20	23.50	0.224	4505	4M51G7W
	16QAM			22.41	22.71	0.187	4512	4M51D7W
10.0	QPSK	2310.0	2310.0	23.20	23.50	0.224	8995	9M00G7W
	16QAM			22.34	22.64	0.184	8995	9M00D7W

5G NR n30

Part 27								
EIRP Limit (W)		0.25						
Antenna Gain (dBi)_Ant(3)		0.30						
Bandwidth (MHz)	Modulation	Low Frequency (MHz)	Upper Frequency (MHz)	Conducted Average (dBm)	EIRP Average (dBm)	EIRP Average (W)	99% BW (kHz)	Emission Designator
5.0	BPSK	2307.5	2312.5	23.20	23.50	0.224	4492	4M49G7W
	QPSK			23.20	23.50	0.224	4485	4M49G7W
	16QAM			23.20	23.50	0.224	4479	4M48D7W
10.0	BPSK	2310.0	2310.0	23.20	23.50	0.224	8977	8M98G7W
	QPSK			23.18	23.48	0.223	8992	8M99G7W
	16QAM			23.15	23.45	0.221	8941	8M94D7W

LTE BAND 41

Part 27								
EIRP Limit (W)								
2.00								
Antenna Gain (dBi)_Ant(3)								
-0.30								
Bandwidth (MHz)	Modulation	Low Frequency (MHz)	Upper Frequency (MHz)	Conducted Average (dBm)	EIRP Average (dBm)	EIRP Average (W)	99% BW (kHz)	Emission Designator
5.0	QPSK	2498.5	2687.5	27.80	27.50	0.562	4487	4M49G7W
	16QAM			28.00	27.70	0.589	4484	4M48D7W
10.0	QPSK	2501.0	2685.0	27.88	27.58	0.573	8974	8M97G7W
	16QAM			28.00	27.70	0.589	8966	8M97D7W
15.0	QPSK	2503.5	2682.5	27.88	27.58	0.573	13474	13M5G7W
	16QAM			28.00	27.70	0.589	13453	13M5D7W
20.0	QPSK	2506.0	2680.0	27.86	27.56	0.570	17950	18M0G7W
	16QAM			28.00	27.70	0.589	17933	17M9D7W

5G NR n41

Part 27								
EIRP Limit (W)								
2.00								
Antenna Gain (dBi)_Ant(3)								
-0.30								
Bandwidth (MHz)	Modulation	Low Frequency (MHz)	Upper Frequency (MHz)	Conducted Average (dBm)	EIRP Average (dBm)	EIRP Average (W)	99% BW (kHz)	Emission Designator
10.0	BPSK	2501.0	2685.0	28.00	27.70	0.589	8616	8M62G7W
	QPSK			27.98	27.68	0.586	8570	8M57G7W
	16QAM			27.24	26.94	0.494	8635	8M64D7W
15.0	BPSK	2503.5	2682.5	28.00	27.70	0.589	12925	12M9G7W
	QPSK			27.91	27.61	0.577	12864	12M9G7W
	16QAM			27.00	26.70	0.468	12912	12M9D7W
20.0	BPSK	2506.5	2680.0	28.00	27.70	0.589	17886	17M9G7W
	QPSK			27.91	27.61	0.577	17922	17M9G7W
	16QAM			26.95	26.65	0.462	17919	17M9D7W
30.0	BPSK	2511.0	2675.0	28.00	27.70	0.589	26835	26M8G7W
	QPSK			27.63	27.33	0.541	26826	26M8G7W
	16QAM			27.00	26.70	0.468	26868	26M9D7W
40.0	BPSK	2516.0	2670.0	28.00	27.70	0.589	35808	35M8G7W
	QPSK			27.81	27.51	0.564	35685	35M7G7W
	16QAM			27.00	26.70	0.468	35703	35M7D7W
50.0	BPSK	2521.0	2665.0	28.00	27.70	0.589	45574	45M6G7W
	QPSK			27.61	27.31	0.538	45761	45M8G7W
	16QAM			26.85	26.55	0.452	45765	45M8D7W
60.0	BPSK	2526.0	2660.0	28.00	27.70	0.589	57884	57M9G7W
	QPSK			27.59	27.29	0.536	58028	58M0G7W
	16QAM			27.10	26.80	0.479	57834	57M8D7W
70.0	BPSK	2531.0	2655.0	28.00	27.70	0.589	64425	64M4G7W
	QPSK			27.72	27.42	0.552	64529	64M5G7W
	16QAM			27.00	26.70	0.468	64451	64M5D7W
80.0	BPSK	2536.0	2650.0	28.00	27.70	0.589	77108	77M1G7W
	QPSK			27.41	27.11	0.514	77372	77M4G7W
	16QAM			27.16	26.86	0.485	77157	77M2D7W
90.0	BPSK	2541.0	2645.0	28.00	27.70	0.589	86766	86M8G7W
	QPSK			27.38	27.08	0.511	86817	86M8G7W
	16QAM			26.68	26.38	0.435	87077	87M1D7W
100.0	BPSK	2546.0	2640.0	28.00	27.70	0.589	96682	96M7G7W
	QPSK			27.19	26.89	0.489	96648	96M6G7W
	16QAM			26.73	26.43	0.440	96848	96M8D7W

LTE BAND 66

Part 27								
EIRP Limit (W)		1.00						
Antenna Gain (dBi)_Ant(3)		-0.70						
Bandwidth (MHz)	Modulation	Low Frequency (MHz)	Upper Frequency (MHz)	Conducted Average (dBm)	EIRP Average (dBm)	EIRP Average (W)	99% BW (kHz)	Emission Designator
1.4	QPSK	1710.7	1779.3	25.50	24.80	0.302	1096	1M10G7W
	16QAM			25.07	24.37	0.274	1093	1M09D7W
3.0	QPSK	1711.5	1778.5	25.50	24.80	0.302	2699	2M70G7W
	16QAM			25.07	24.37	0.274	2701	2M70D7W
5.0	QPSK	1712.5	1777.5	25.50	24.80	0.302	4518	4M52G7W
	16QAM			25.02	24.32	0.270	4503	4M50D7W
10.0	QPSK	1715.0	1775.0	25.50	24.80	0.302	8986	8M99G7W
	16QAM			25.04	24.34	0.272	8988	8M99D7W
15.0	QPSK	1717.5	1772.5	25.50	24.80	0.302	13446	13M4G7W
	16QAM			25.12	24.42	0.277	13457	13M5D7W
20.0	QPSK	1720.0	1770.0	25.50	24.80	0.302	17927	17M9G7W
	16QAM			25.24	24.54	0.284	17926	17M9D7W

5G NR n66

Part 27								
EIRP Limit (W)		1.00						
Antenna Gain (dBi)_Ant(3)		-0.40						
Bandwidth (MHz)	Modulation	Low Frequency (MHz)	Upper Frequency (MHz)	Conducted Average (dBm)	EIRP Average (dBm)	EIRP Average (W)	99% BW (kHz)	Emission Designator
5.0	BPSK	1712.5	1777.5	25.44	25.04	0.319	4509	4M51G7W
	QPSK			25.50	25.10	0.324	4516	4M52G7W
	16QAM			24.99	24.59	0.288	4470	4M47D7W
10.0	BPSK	1715.0	1775.0	25.50	25.10	0.324	8935	8M94G7W
	QPSK			25.50	25.10	0.324	8970	8M97G7W
	16QAM			25.22	24.82	0.303	8992	8M99D7W
15.0	BPSK	1717.5	1772.5	25.45	25.05	0.320	13489	13M5G7W
	QPSK			25.50	25.10	0.324	13457	13M5G7W
	16QAM			25.15	24.75	0.299	13467	13M5D7W
20.0	BPSK	1720.0	1770.0	25.45	25.05	0.320	17922	17M9G7W
	QPSK			25.50	25.10	0.324	17911	17M9G7W
	16QAM			24.97	24.57	0.286	17827	17M8D7W
25.0	BPSK	1722.5	1767.5	25.50	25.10	0.324	22903	22M9G7W
	QPSK			25.44	25.04	0.319	22869	22M9G7W
	16QAM			25.39	24.99	0.316	22866	22M9D7W
30.0	BPSK	1725.0	1765.0	25.50	25.10	0.324	28590	28M6G7W
	QPSK			25.47	25.07	0.321	28574	28M6G7W
	16QAM			25.30	24.90	0.309	28600	28M6D7W
35.0	BPSK	1727.5	1767.5	25.50	25.10	0.324	30171	30M2G7W
	QPSK			25.21	24.81	0.303	30160	30M2G7W
	16QAM			24.67	24.27	0.267	30140	30M1D7W
40.0	BPSK	1730.0	1760.0	25.46	25.06	0.321	38641	38M6G7W
	QPSK			25.50	25.10	0.324	38618	38M6G7W
	16QAM			25.08	24.68	0.294	38604	38M6D7W

5G NR n70

Part 27								
EIRP Limit (W)		1.00						
Antenna Gain (dBi)_Ant(3)		-0.20						
Bandwidth (MHz)	Modulation	Low Frequency (MHz)	Upper Frequency (MHz)	Conducted Average (dBm)	EIRP Average (dBm)	EIRP Average (W)	99% BW (kHz)	Emission Designator
5.0	BPSK	1697.5	1707.5	25.50	25.30	0.339	4505	4M51G7W
	QPSK			25.49	25.29	0.338	4505	4M51G7W
	16QAM			24.92	24.72	0.296	4489	4M49D7W
10.0	BPSK	1700.0	1705.0	25.50	25.30	0.339	8965	8M97G7W
	QPSK			25.48	25.28	0.337	8978	8M98G7W
	16QAM			25.19	24.99	0.316	8969	8M97D7W
15.0	BPSK	1702.5	1702.5	25.50	25.30	0.339	13433	13M4G7W
	QPSK			25.41	25.21	0.332	13410	13M4G7W
	16QAM			24.81	24.61	0.289	13423	13M4D7W

LTE BAND 71

Part 27								
ERP Limit (W)		3.00						
Antenna Gain (dBi)_Ant(1)		-3.90						
Bandwidth (MHz)	Modulation	Low Frequency (MHz)	Upper Frequency (MHz)	Conducted Average (dBm)	ERP Average (dBm)	ERP Average (W)	99% BW (kHz)	Emission Designator
5.0	QPSK	665.5	695.5	25.70	19.65	0.092	4505	4M51G7W
	16QAM			25.70	19.65	0.092	4499	4M50D7W
10.0	QPSK	668.0	693.0	25.70	19.65	0.092	8953	8M95G7W
	16QAM			25.49	19.44	0.088	8967	8M97D7W
15.0	QPSK	670.5	690.5	25.70	19.65	0.092	13422	13M4G7W
	16QAM			25.48	19.43	0.088	13420	13M4D7W
20.0	QPSK	673.0	688.0	25.70	19.65	0.092	17880	17M9G7W
	16QAM			25.70	19.65	0.092	17888	17M9D7W

5G NR n71

Part 27								
ERP Limit (W)		3.00						
Antenna Gain (dBi)_Ant(1)		-3.90						
Bandwidth (MHz)	Modulation	Low Frequency (MHz)	Upper Frequency (MHz)	Conducted Average (dBm)	ERP Average (dBm)	ERP Average (W)	99% BW (kHz)	Emission Designator
5.0	BPSK	665.5	695.5	25.65	19.60	0.091	4457	4M46G7W
	QPSK			25.70	19.65	0.092	4491	4M49G7W
	16QAM			25.36	19.31	0.085	4487	4M49D7W
10.0	BOSK	668.0	693.0	25.70	19.65	0.092	8963	8M96G7W
	QPSK			25.68	19.63	0.092	8967	8M97G7W
	16QAM			25.52	19.47	0.089	8946	8M95D7W
15.0	BPSK	670.5	690.5	25.70	19.65	0.092	13385	13M4G7W
	QPSK			25.68	19.63	0.092	13422	13M4G7W
	16QAM			25.52	19.47	0.089	13383	13M4D7W
20.0	BPSK	673.0	688.0	25.70	19.65	0.092	17889	17M9G7W
	QPSK			25.64	19.59	0.091	17843	17M8G7W
	16QAM			25.32	19.27	0.085	17818	17M8D7W

5G NR n77 (FCC Part 27 3450-3550MHz)

Part 27								
EIRP Limit (W)		1.00						
Antenna Gain (dBi)_Ant(9)		-0.40						
Bandwidth (MHz)	Modulation	Low Frequency (MHz)	Upper Frequency (MHz)	Conducted Average (dBm)	EIRP Average (dBm)	EIRP Average (W)	99% BW (kHz)	Emission Designator
10.0	BPSK	3455.0	3545.0	28.67	28.27	0.671	8631	8M63G7W
	QPSK			28.70	28.30	0.676	8628	8M63G7W
	16QAM			28.07	27.67	0.585	8647	8M65D7W
15.0	BPSK	3457.5	3542.5	28.70	28.30	0.676	12907	12M9G7W
	QPSK			28.65	28.25	0.668	12892	12M9G7W
	16QAM			28.15	27.75	0.596	12910	12M9D7W
20.0	BPSK	3460.0	3540.0	28.70	28.30	0.676	17866	17M9G7W
	QPSK			28.70	28.30	0.676	17912	17M9G7W
	16QAM			28.13	27.73	0.593	17954	18M0D7W
30.0	BPSK	3465.0	3535.0	28.56	28.16	0.655	26798	26M8G7W
	QPSK			28.70	28.30	0.676	26799	26M8G7W
	16QAM			27.84	27.44	0.555	26816	26M8D7W
40.0	BPSK	3470.0	3530.0	28.70	28.30	0.676	35681	35M7G7W
	QPSK			28.69	28.29	0.675	35801	35M8G7W
	16QAM			28.05	27.65	0.582	35803	35M8D7W
50.0	BPSK	3475.0	3525.0	28.70	28.30	0.676	45745	45M7G7W
	QPSK			28.63	28.23	0.665	45662	45M7G7W
	16QAM			28.06	27.66	0.583	45826	45M8D7W
60.0	BPSK	3480.0	3520.0	28.70	28.30	0.676	57845	57M8G7W
	QPSK			28.63	28.23	0.665	57901	57M9G7W
	16QAM			28.06	27.66	0.583	57934	57M9D7W
70.0	BPSK	3485.0	3515.0	28.63	28.23	0.665	64320	64M3G7W
	QPSK			28.70	28.30	0.676	64337	64M3G7W
	16QAM			28.65	28.25	0.668	64267	64M3D7W
80.0	BPSK	3490.0	3510.0	28.57	28.17	0.656	77239	77M2G7W
	QPSK			28.70	28.30	0.676	77076	77M1G7W
	16QAM			28.18	27.78	0.600	77097	77M1D7W
90.0	BPSK	3495.0	3505.0	28.62	28.22	0.664	86900	86M9G7W
	QPSK			28.70	28.30	0.676	86696	86M7G7W
	16QAM			28.07	27.67	0.585	86757	86M8D7W
100.0	BPSK	3500.0	3500.0	28.50	28.10	0.646	96340	96M3G7W
	QPSK			28.70	28.30	0.676	96530	96M5G7W
	16QAM			27.87	27.47	0.558	96535	96M5D7W

5G NR n77 (FCC Part 27 3700-3980MHz)

Part 27								
EIRP Limit (W)		1.00						
Antenna Gain (dBi)_Ant(9)		-0.60						
Bandwidth (MHz)	Modulation	Low Frequency (MHz)	Upper Frequency (MHz)	Conducted Average (dBm)	EIRP Average (dBm)	EIRP Average (W)	99% BW (kHz)	Emission Designator
10.0	BPSK	3705.0	3975.0	28.69	28.09	0.644	8624	8M62G7W
	QPSK			28.70	28.10	0.646	8603	8M60G7W
	16QAM			28.08	27.48	0.560	8637	8M64D7W
15.0	BPSK	3707.5	3972.5	28.59	27.99	0.630	12886	12M9G7W
	QPSK			28.70	28.10	0.646	12920	12M9G7W
	16QAM			28.07	27.47	0.558	12896	12M9D7W
20.0	BPSK	3710.0	3970.0	28.70	28.10	0.646	17910	17M9G7W
	QPSK			28.64	28.04	0.637	17809	17M8G7W
	16QAM			27.91	27.31	0.538	17927	17M9D7W
30.0	BPSK	3715.0	3965.0	28.69	28.09	0.644	26756	26M8G7W
	QPSK			28.70	28.10	0.646	26979	27M0G7W
	16QAM			27.93	27.33	0.541	26885	26M9D7W
40.0	BPSK	3720.0	3960.0	28.70	28.10	0.646	35711	35M7G7W
	QPSK			28.70	28.10	0.646	35764	35M8G7W
	16QAM			27.87	27.27	0.533	35640	35M6D7W
50.0	BPSK	3725.0	3955.0	28.70	28.10	0.646	45852	45M9G7W
	QPSK			28.63	28.03	0.635	45778	45M8G7W
	16QAM			28.10	27.50	0.562	45675	45M7D7W
60.0	BPSK	3730.0	3950.0	28.70	28.10	0.646	57976	58M0G7W
	QPSK			28.57	27.97	0.627	57943	57M9G7W
	16QAM			27.89	27.29	0.536	57983	58M0D7W
70.0	BPSK	3735.0	3945.0	28.68	28.08	0.643	64370	64M4G7W
	QPSK			28.70	28.10	0.646	64347	64M3G7W
	16QAM			27.98	27.38	0.547	64557	64M6D7W
80.0	BPSK	3740.0	3940.0	28.66	28.06	0.640	77243	77M2G7W
	QPSK			28.70	28.10	0.646	77058	77M1G7W
	16QAM			27.88	27.28	0.535	77164	77M2D7W
90.0	BPSK	3745.0	3935.0	28.70	28.10	0.646	86741	86M7G7W
	QPSK			28.68	28.08	0.643	86882	86M9G7W
	16QAM			27.87	27.27	0.533	86690	86M7D7W
100.0	BPSK	3750.0	3930.0	28.69	28.09	0.644	96453	96M5G7W
	QPSK			28.70	28.10	0.646	96283	96M3G7W
	16QAM			27.91	27.31	0.538	96387	96M4D7W

6.3. SOFTWARE AND FIRMWARE

The EUT firmware installed during testing was version 0.02.01.

6.4. MAXIMUM ANTENNA GAIN

The antenna(s) gain and type, as provided by the manufacturer' are as follows:

LTE and 5G NR Bands	Frequency Range (MHz)	ANT 1 Antenn a Gain (dBi)	ANT 2 Antenn a Gain (dBi)	ANT 3 Antenn a Gain (dBi)	ANT 4 Antenn a Gain (dBi)	ANT 7 Antenn a Gain (dBi)	ANT 8 Antenn a Gain (dBi)	ANT 9 Antenn a Gain (dBi)
LTE Band 5, 5G NR n5	824 – 849	-5.1	-4.7					
LTE Band 7, 5G NR n7	2500 – 2570	-3.2	-1.4	0.3	-0.7			
LTE Band 12, 5G NR n12	699 – 716	-4.4	-4.7					
LTE Band 13	777 – 787	-5.1	-4.9					
LTE Band 14, 5G NR n14	788 – 798	-5.1	-4.9					
LTE Band 17	704 – 716	-4.4	-4.7					
LTE Band 25, 5G NR n25	1850 – 1915	-2.7	-2.5	-0.6	-0.5			
LTE Band 26 ,5G NR 26	814 – 849	-5.1	-4.7					
LTE Band 30, 5G NR n30	2305 – 2315	-4.1	0.8	0.3	-0.9			
LTE Band 41, 5G NR n41	2496 – 2690	-2.4	-1.4	-0.3	-1.2			
LTE Band 66, 5G NR n66	1710 – 1780	-3.2	-3.0	-0.7	-1.7			
5G NR n70	1695 – 1710	-3.0	-4.0	-0.2	-3.3			
LTE Band 71, 5G NR n71	663 – 698	-3.9	-4.8					
5G NR n77	3450 – 3550				-3.4	-2.8	-2.6	-0.4
5G NR n77	3700 – 3980				-3.3	-3.3	-3.4	-0.6

6.5. WORST-CASE CONFIGURATION AND MODE

The EUT supports the following LTE and 5G NRs:

Band 2, Band 4, Band 5, Band 7, Band 12, Band 13, Band 14, Band 17, Band 25, Band 26, Band 30, Band 41, Band 48, Band 53, Band 66, Band 71, 5G NR n2, 5G NR n5, 5G NR n7, 5G NR n12, 5G NR n14, 5G NR n25, 5G NR n26, 5G NR n30, 5G NR n41, 5G NR n53, 5G NR n66, 5G NR n70, 5G NR n71, and 5G NR n77.

LTE Band 2 and 5G NR n2 (1850-1910MHz) are covered by LTE Band 25 and 5G NR n25 respectively. Because they are the subset of LTE band 25 and 5G NR n25 with the same output power and supported bandwidths.

LTE Band 4 (1710-1755MHz, 5/10/15/20MHz bandwidth) is covered by LTE Band 66 because it is a subset of LTE band 66 and they have same output power.

FCC rule Part 22.905 of LTE Band 5 and 5G NR n5 (824-849MHz) is covered by LTE Band 26 and 5G NR n26 of same rule since they have the same output power and supported bandwidths.

For 5G NRs, conducted spurious emission tests were conducted on wider bandwidth with inner 1RB since this is the worst bandwidth and the highest output power.

BPSK modulation applied only for 5G NR frequencies and has the same tune up power as QPSK modulations.

The DFT-s-OFDM and CP-OFDM waveforms were investigated, and DFT-s-OFDM was found to be the worst case.

The worst-case scenario for all measurements is based on an engineering evaluation made on different modulations. Then, QPSK and BPSK were observed as the worst mode to LTE bands and 5G NR bands respectively and set for all conducted and radiated. Output power measurements were measured on BPSK, QPSK, 16QAM, 64QAM, and 256QAM modulations. For testing purposes emissions on sections 8 and 9 were measured while QPSK/BPSK was set at or above target power for all bands. Conducted tests were performed on the worst-case antenna port because it has the highest conducted power. The worst-case antenna port is shown in the table below.

LTE and 5G NR Bands	Worst case Antenna Port for Conducted Power
LTE BAND 26 and 5G NR n26	Ant 1
LTE BAND 7 and 5G NR n7	
LTE BAND 12 and 5G NR n12	
LTE BAND 13	
LTE BAND 14 and 5G NR n12	
LTE Band 17	
LTE BAND 25 and 5G NR n25	
LTE BAND 30 and 5G NR n30	
LTE BAND 41	
LTE BAND 66 and 5G NR n66	
LTE BAND 71 and 5G NR n71	
5G NR n41	
5G NR n77	Ant 7

The EUT was investigated in three orthogonal orientations X/Y/Z on all ANT 1, ANT2, ANT3, ANT4, ANT7, ANT8 and ANT 9 antennas to determine the worst case orientation. The following table exhibit the worst case orientation for different frequency bands. The full tests of the EUT have made upon the orientations that shown in the table below.

Frequency Bands	ANT1	ANT2	ANT3	ANT4	ANT7	ANT8	ANT9
663 – 849 MHz	X	X	N/A	N/A	N/A	N/A	N/A
1710 – 1915 MHz	X	Y	X	X	N/A	N/A	N/A
2300 – 2700 MHz	X	Z	Y	Y	N/A	N/A	N/A
3300 – 3980 MHz	N/A	N/A	N/A	X	X	X	X

Radiated spurious emissions were investigated from 9kHz to 30MHz, 30MHz-1GHz and above 18GHz. There were no emissions found with less than 20dB of margin from 9kHz to 30MHz, 30MHz-1GHz and above 18GHz.

For simultaneous transmission of multiple channels in the 2.4GHz/5GHz WLAN, UWB, and Cellular bands, tests were conducted for various configurations having the highest power, least separation in frequencies and widest operation bandwidths. No noticeable new emission was found.

6.6. DESCRIPTION OF TEST SETUP

SUPPORT TEST EQUIPMENT						
Description	Manufacturer	Model	Serial Number	FCC ID/ DoC		
Laptop	Apple	MacBook Pro	HRP082673	BCGA1708		
AC/DC adapter	Apple	A1718	C4H64450HH3GN8RA6	--		
I/O CABLES (RF CONDUCTED TEST)						
Cable No.	Port	# of Identical Ports	Connector Type	Cable Type	Cable Length (m)	Remarks
1	AC	3	US 115V	Un-shielded	2.0	N/A
2	USB	1	DC	Un-shielded	1.0	N/A
3	RF In/Out	1	EUT	Un-shielded	0.6	N/A
4	RF In/Out	1	Communication Test Set	Un-shielded	1.2	N/A
5	RF In/Out	1	Barrel	N/A	N/A	N/A
I/O CABLES (RF RADIATED TEST)						
Cable No.	Port	# of Identical Ports	Connector Type	Cable Type	Cable Length (m)	Remarks
1	RF In/Out	1	Antenna	Un-shielded	5.0	N/A

CONDUCTED SETUP

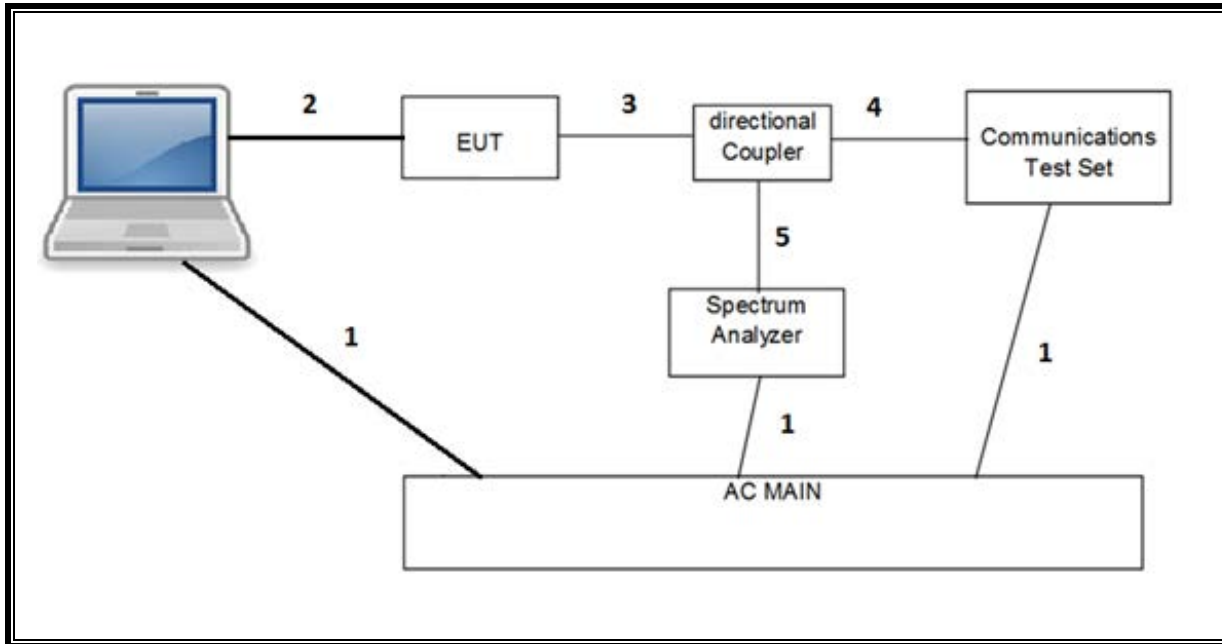

RADIATED SETUP

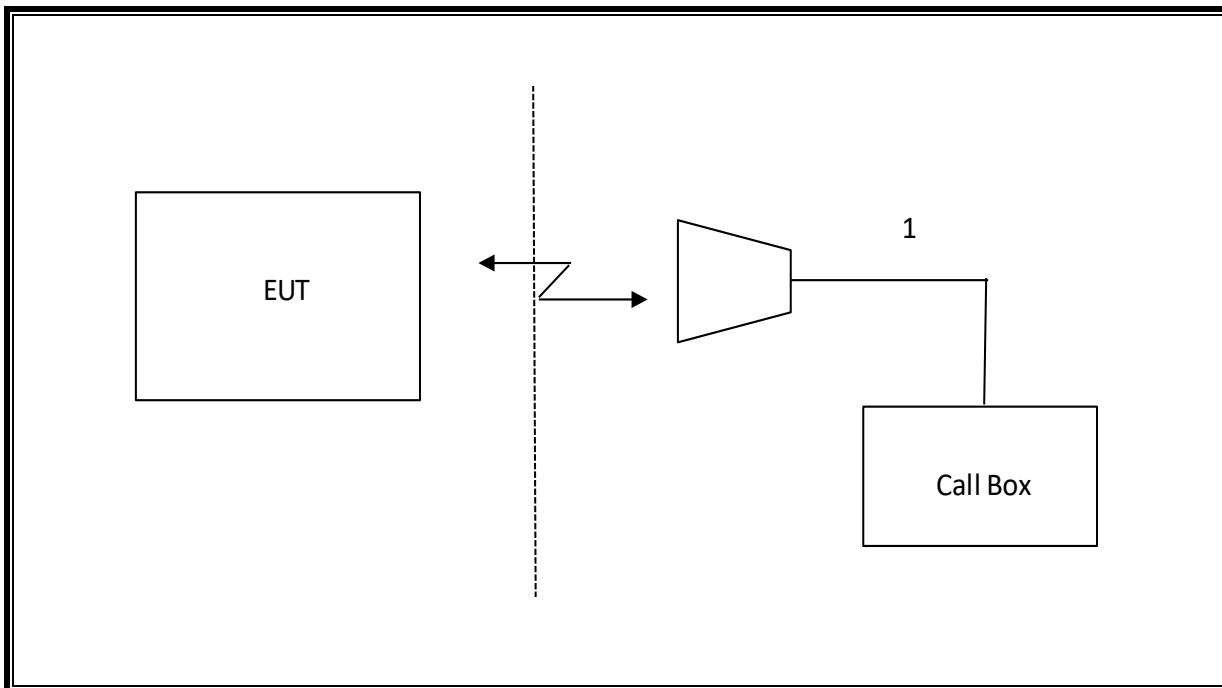

7. TEST AND MEASUREMENT EQUIPMENT

The following test and measurement equipment was utilized for the tests documented in this report:

TEST EQUIPMENT LIST				
Description	Manufacturer	Model	Asset	Cal Due
Antenna, Horn 1-18GHz	ETS-Lindgren	3117	80430	2024-08-31
Antenna, Horn 1-18GHz	ETS Lindgren	3117	79834	2024-06-30
Antenna, Broadband Hybrid, 30MHz to 3000MHz	SUNAR	JB3	222009	2024-10-31
Antenna, Passive Loop 30Hz - 1MHz	ELECTRO-METRICS	EM-6871	170014	2024-08-31
Antenna, Passive Loop 100KHz - 30MHz	ELECTRO-METRICS	EM-6872	170016	2024-08-31
RF Filter Box, 1-18GHz	UL-FR1	NA	217255	2024-10-31
RF Filter Box, 1-18GHz	UL-FR1	RATS 2	226781	2024-09-30
Amplifier, 10KHz to 1GHz, 32dB	Sonoma	310N	430250	2024-09-30
EMI TEST RECEIVER	Rohde & Schwarz	ESW44	169936	2025-02-28
EMI TEST RECEIVER	Rohde & Schwarz	ESW44	169935	2025-02-28
Wideband Communication Test Set, Call Box	R&S GmbH & Co. KG	CMW500	85943	2025-02-28
Directional Coupler	KRYTAR	152610	198816	2024-10-31
Directional Coupler	KRYTAR	152610	231664	2025-01-22
Power Meter, P-series single channel	Keysight	N1912A	90719	2025-01-31
Power Sensor, P - series, 50MHz to 18GHz, Wideband	Keysight	N1921A	81319	2025-01-31
Filter, HPF 1.2GHz	Wainwright Instruments GmbH	WHKX6-948-1.2/15G-40ST	99	2024-10-31
Spectrum Analyzer, PXA, 2Hz to 44GHz	Keysight	N9030B	231739	2025-01-31
Spectrum Analyzer, PXA, 2Hz to 44GHz	Keysight	N9030B	245120	2025-02-28
Spectrum Analyzer, PXA, 3Hz to 44GHz	Keysight	N9030A	85212	2025-02-28
Wideband Communication Test Set, Call Box	R&S GmbH & Co. KG	CMW500	222793	2025-02-28
Wideband Communication Test Set, Call Box	R&S GmbH & Co. KG	CMW500	222797	2025-02-28
Chamber, Environmental	Thermotron Corp.	SM-16C Mini-Max	179936	2024-06-30
Transmitting Antenna, Horn Antenna	TEKBOX Digital Solutions	TBMA4	226709	C.N.R.
Antenna, Horn 18 to 26.5GHz	A.R.A.	MWH-1826/B	199659	2024-12-31
*Amplifier 18-26.5GHz, +5Vdc, -54dBm P1dB	AMPLICAL	AMP18G26.5-60	234683	2024-03-29
DC Power Supply	GWINSTEK	GPS18500	N/A	C.N.R.
UL AUTOMATION SOFTWARE				
CLT Software	UL	UL RF	V2023.11.21.0	
Power Measurement Software	UL	UL RF	V2023.08.14.0	
Radiated test software	UL	UL RF	Ver 9.5 2023-05-01	

NOTES:

- * Testing is completed before equipment expiration date.

8. RF OUTPUT POWER MEASUREMENTS

CONDUCTED OUTPUT POWER MEASUREMENT PROCEDURE

All LTE bands conducted average power is obtained from the CMW500 telecommunication test set.

The following tests were conducted according to the test requirements outlined in section 6.2 of the 3GPP TS 36.101 specification.

UE Power Class: 3 (23 +/- 2dBm). Band 41 UE Power Class: 2 (26 +/-2 dBm).The allowed Maximum Power Reduction (MPR) for the maximum output power due to higher order modulation and transmit bandwidth configuration (resource blocks) is specified in Table 6.2.3-1 of the 3GPP TS 36.101.

Table 6.2.3-1: Maximum Power Reduction (MPR) for Power Class 1, 2 and 3

Modulation	Channel bandwidth / Transmission bandwidth (N_{RB})						MPR (dB)
	1.4 MHz	3.0 MHz	5 MHz	10 MHz	15 MHz	20 MHz	
QPSK	> 5	> 4	> 8	> 12	> 16	> 18	≤ 1
16 QAM	≤ 5	≤ 4	≤ 8	≤ 12	≤ 16	≤ 18	≤ 1
16 QAM	> 5	> 4	> 8	> 12	> 16	> 18	≤ 2
64 QAM	≤ 5	≤ 4	≤ 8	≤ 12	≤ 16	≤ 18	≤ 2
64 QAM	> 5	> 4	> 8	> 12	> 16	> 18	≤ 3
256 QAM	≥ 1						≤ 5

The allowed A-MPR values specified below in Table 6.2.4.-1 of 3GPP TS 36.101 are in addition to the allowed MPR requirements. All the measurements below were performed with A-MPR disabled, by using Network Signaling Value of "NS_01".

Table 6.2.4-1: Additional Maximum Power Reduction (A-MPR)

Network Signalling value	Requirements (subclause)	E-UTRA Band	Channel bandwidth (MHz)	Resources Blocks (N_{RB})	A-MPR (dB)
NS_01	6.6.2.1.1	Table 5.5-1	1.4, 3, 5, 10, 15, 20	Table 5.6-1	N/A
NS_03	6.6.2.2.1	2, 4, 10, 23, 25, 35, 36, 66, 70	3	>5	≤ 1
			5	>6	≤ 1
			10	>6	≤ 1
			15	>8	≤ 1
NS_04	6.6.2.2.2, 6.6.3.3.19	41	5, 10, 15, 20	Table 6.2.4-4, Table 6.2.4-4a	

RESULTS

EUT includes different power levels for head use configuration and body use configuration and the below tables contain the highest of all configurations average conducted output powers as follows:

8.1. LTE BAND 7 AND 5G NR n7

LTE BAND 7

Test Engineer ID:	12482	Test Date:	2024-02-22
-------------------	-------	------------	------------

OUTPUT POWER FOR LTE BAND 7 (5.0 MHz)

Bandwidth (MHz)	Modulation	RB Allocation	RB Offset	Conducted Average (dBm)											
				ANT 1			ANT 2			ANT 3			ANT 4		
				20775	21100	21425	20775	21100	21425	20775	21100	21425	20775	21100	21425
5.0	QPSK	1	0	25.29	25.25	25.47	23.45	23.49	23.56	24.31	24.42	24.80	22.56	22.45	22.51
		1	12	25.39	25.41	25.57	23.54	23.58	23.70	24.52	24.56	25.00	22.70	22.54	22.55
		1	24	25.30	25.34	25.54	23.45	23.47	23.31	24.49	24.48	24.89	22.68	22.42	22.06
		12	0	25.34	25.28	25.49	22.47	22.49	22.52	23.69	23.80	24.11	21.62	21.45	21.52
		12	6	25.36	25.42	25.60	22.51	22.53	22.64	23.76	23.83	24.15	21.68	21.48	21.58
	16QAM	1	0	25.34	25.37	25.56	22.49	22.48	22.63	23.81	23.81	24.20	21.65	21.42	21.56
		25	0	25.36	25.37	25.55	22.51	22.49	22.54	23.75	23.80	24.10	21.64	21.44	21.48
		1	0	25.51	25.36	25.70	22.69	22.62	22.68	23.80	24.01	24.35	21.67	21.61	21.69
		1	12	25.57	25.47	25.66	22.75	22.68	22.82	24.06	24.07	24.49	21.77	21.64	21.71
		1	24	25.49	25.46	25.29	22.67	22.60	22.62	24.03	23.96	24.38	21.74	21.62	21.33
	64QAM	12	0	24.40	24.30	24.58	21.57	21.49	21.47	22.70	22.77	23.11	20.69	20.45	20.65
		12	6	24.45	24.42	24.67	21.62	21.53	21.59	22.79	22.79	23.17	20.72	20.48	20.70
		12	11	24.40	24.36	24.64	21.56	21.52	21.55	22.82	22.77	23.21	20.71	20.45	20.67
		25	0	24.35	24.37	24.53	21.50	21.51	21.54	22.75	22.79	23.11	20.64	20.44	20.59
		1	0	24.62	24.50	24.77	21.72	21.73	21.77	22.79	23.04	23.33	20.81	20.72	20.82
	256QAM	1	12	24.64	24.62	24.80	21.75	21.68	21.83	23.00	23.08	23.45	20.87	20.67	20.87
		1	24	24.55	24.61	24.77	21.77	21.71	21.72	23.07	23.08	23.43	20.88	20.65	20.90
		12	0	23.36	23.23	23.43	20.49	20.45	20.47	21.61	21.75	22.23	19.62	19.50	19.58
		12	6	23.42	23.35	23.56	20.51	20.49	20.59	21.71	21.78	22.29	19.69	19.53	19.63
		12	11	23.38	23.31	23.51	20.51	20.47	20.57	21.72	21.74	22.38	19.68	19.54	19.63

OUTPUT POWER FOR LTE BAND 7 (10.0 MHz)

Bandwidth (MHz)	Modulation	RB Allocation	RB Offset	Conducted Average (dBm)											
				ANT 1			ANT 2			ANT 3			ANT 4		
				20800	21100	21400	20800	21100	21400	20800	21100	21400	20800	21100	21400
10.0	QPSK	1	0	25.34	25.32	25.44	23.55	23.57	23.67	24.47	24.64	24.90	22.62	22.45	22.54
		1	24	25.33	25.37	25.49	23.59	23.58	23.70	24.72	24.65	24.95	22.70	22.43	22.57
		1	49	25.32	25.35	25.52	23.52	23.56	23.36	24.75	24.65	25.00	22.68	22.46	22.58
		25	0	25.38	25.32	25.47	22.60	22.60	22.72	23.93	23.97	24.24	21.67	21.46	21.50
		25	12	25.42	25.41	25.60	22.55	22.63	22.75	23.95	24.01	24.25	21.61	21.47	21.55
	16QAM	25	24	25.38	25.40	25.58	22.51	22.60	22.73	23.97	23.99	24.36	21.61	21.45	21.60
		50	0	25.39	25.39	25.56	22.51	22.59	22.71	23.91	23.99	24.32	21.60	21.44	21.54
		1	0	25.58	25.46	25.64	22.76	22.79	22.84	24.01	24.14	24.46	21.69	21.62	21.71
		1	24	25.48	25.53	25.70	22.76	22.73	22.78	24.10	24.09	24.44	21.79	21.58	21.74
		1	49	25.45	25.53	25.58	22.67	22.77	22.85	24.21	24.16	24.48	21.82	21.59	21.73
	64QAM	25	0	24.37	24.33	24.46	21.59	21.61	21.71	22.95	23.02	23.23	20.67	20.47	20.54
		25	12	24.40	24.40	24.58	21.55	21.62	21.76	22.94	23.00	23.25	20.64	20.49	20.55
		25	24	24.37	24.39	24.54	21.54	21.61	21.74	22.98	22.98	23.34	20.64	20.48	20.63
		50	0	24.35	24.38	24.53	21.53	21.63	21.71	22.92	22.95	23.31	20.61	20.43	20.52
		1	0	24.53	24.59	24.72	21.88	21.86	21.85	23.05	23.21	23.47	20.90	20.76	20.87
	256QAM	1	24	24.54	24.56	24.78	21.86	21.88	21.87	23.26	23.21	23.52	20.93	20.69	20.87
		1	49	24.58	24.55	24.78	21.81	21.75	21.89	23.34	23.32	23.64	20.98	20.71	20.88
		25	0	23.36	23.29	23.47	20.63	20.53	20.64	21.91	22.02	22.19	19.69	19.47	19.52
		25	12	23.38	23.40	23.58	20.57	20.56	20.67	21.96	22.01	22.23	19.69	19.44	19.58
		25	24	23.34	23.35	23.55	20.55	20.53	20.65	21.95	21.96	22.31	19.67	19.46	19.62

OUTPUT POWER FOR LTE BAND 7 (15.0 MHz)

Bandwidth (MHz)	Modulation	RB Allocation	RB Offset	Conducted Average (dBm)											
				ANT 1			ANT 2			ANT 3			ANT 4		
				20825	21100	21375	20825	21100	21375	20825	21100	21375	20825	21100	21375
15.0	QPSK	1	0	25.32	25.31	25.46	23.53	23.60	23.61	24.57	24.77	24.88	22.67	22.49	22.54
		1	37	25.31	25.34	25.54	23.56	23.57	23.70	24.84	24.69	24.96	22.70	22.50	22.60
		1	74	25.26	25.27	25.51	23.45	23.53	23.59	24.80	24.74	25.00	22.59	22.46	22.55
		36	0	25.38	25.36	25.54	22.58	22.60	22.62	24.09	24.09	24.28	21.73	21.52	21.54
		36	16	25.41	25.45	25.54	22.61	22.61	22.66	24.10	24.09	24.31	21.69	21.52	21.63
		36	35	25.37	25.42	25.61	22.50	22.60	22.72	24.09	24.08	24.39	21.70	21.50	21.64
		75	0	25.39	25.42	25.61	22.51	22.58	22.63	24.05	24.10	24.30	21.67	21.51	21.61
		1	0	25.44	25.50	25.66	22.64	22.69	22.78	24.15	24.16	24.32	21.83	21.56	21.63
		1	37	25.48	25.57	25.70	22.69	22.68	22.83	24.38	24.12	24.48	21.92	21.66	21.74
		1	74	25.43	25.49	25.64	22.57	22.63	22.80	24.33	24.22	24.46	21.84	21.60	21.67
		36	0	24.40	24.38	24.53	21.61	21.64	21.63	23.07	23.08	23.29	20.73	20.55	20.53
		36	16	24.40	24.45	24.53	21.62	21.63	21.65	23.07	23.09	23.30	20.72	20.54	20.65
	36	35	24.35	24.40	24.59	21.53	21.60	21.74	23.07	23.07	23.38	20.71	20.54	20.63	
	75	0	24.38	24.40	24.59	21.53	21.62	21.63	23.06	23.09	23.30	20.69	20.55	20.64	
	1	0	24.61	24.59	24.78	21.81	21.78	21.90	23.19	23.27	23.46	21.01	20.80	20.74	
	1	37	24.63	24.65	24.82	21.87	21.79	21.92	23.42	23.32	23.54	21.09	20.79	20.87	
	1	74	24.61	24.64	24.79	21.79	21.75	21.88	23.42	23.27	23.48	21.00	20.79	20.78	
	36	0	23.37	23.36	23.48	20.57	20.51	20.53	22.07	22.08	22.26	19.81	19.57	19.54	
	36	16	23.38	23.43	23.48	20.61	20.53	20.55	22.08	22.08	22.28	19.80	19.57	19.65	
	36	35	23.35	23.38	23.53	20.52	20.48	20.63	22.08	22.05	22.35	19.78	19.58	19.64	
	75	0	23.38	23.40	23.56	20.52	20.51	20.57	22.06	22.08	22.27	19.77	19.59	19.65	
	1	0	21.38	21.37	21.56	18.61	18.63	18.48	20.01	20.15	20.27	17.84	17.57	17.59	
	1	37	21.45	21.46	21.59	18.65	18.60	18.59	20.20	20.08	20.29	17.97	17.57	17.65	
	1	74	21.46	21.47	21.66	18.63	18.63	18.69	20.19	20.19	20.41	17.91	17.72	17.77	
	36	0	21.34	21.31	21.44	18.59	18.53	18.52	20.06	20.03	20.21	17.76	17.57	17.56	
	36	16	21.34	21.37	21.45	18.59	18.52	18.53	20.07	20.05	20.22	17.74	17.58	17.63	
	36	35	21.34	21.36	21.51	18.51	18.52	18.63	20.07	20.03	20.31	17.74	17.59	17.65	
	75	0	21.33	21.37	21.53	18.53	18.52	18.55	20.05	20.05	20.27	17.73	17.58	17.65	

OUTPUT POWER FOR LTE BAND 7 (20.0 MHz)

Bandwidth (MHz)	Modulation	RB Allocation	RB Offset	Conducted Average (dBm)											
				ANT 1			ANT 2			ANT 3			ANT 4		
				20850	21100	21350	20850	21100	21350	20850	21100	21350	20850	21100	21350
20.0	QPSK	1	0	25.04	25.01	25.14	23.59	23.58	23.67	24.54	24.72	24.80	22.57	22.53	22.47
		1	49	25.00	25.05	25.18	23.57	23.60	23.70	24.81	24.71	24.88	22.70	22.49	22.56
		1	99	24.99	25.05	25.19	23.51	23.54	23.49	24.80	24.81	25.00	22.62	22.49	22.48
		50	0	25.04	25.09	25.24	22.65	22.68	22.68	24.10	24.12	24.21	21.79	21.59	21.52
		50	24	25.12	25.18	25.32	22.59	22.66	22.71	24.11	24.12	24.28	21.81	21.62	21.62
		50	49	25.08	25.14	25.28	22.56	22.63	22.75	24.09	24.09	24.27	21.71	21.57	21.61
		100	0	25.09	25.16	25.29	22.58	22.66	22.68	24.07	24.11	24.28	21.72	21.59	21.60
		1	0	25.19	25.29	25.49	22.77	22.68	22.76	24.02	24.26	24.26	21.79	21.74	21.58
		1	49	25.35	25.52	25.70	22.96	22.92	23.04	24.61	24.41	24.56	22.16	21.88	21.91
		1	99	25.04	25.25	25.46	22.70	22.62	22.83	24.23	24.26	24.40	21.80	21.74	21.69
		50	0	24.03	24.10	24.23	21.68	21.68	21.66	23.11	23.14	23.20	20.75	20.58	20.54
		50	24	24.11	24.16	24.26	21.59	21.68	21.70	23.10	23.10	23.29	20.80	20.57	20.62
	50	49	24.05	24.11	24.28	21.55	21.65	21.77	23.11	23.11	23.29	20.71	20.55	20.64	
	100	0	24.10	24.12	24.26	21.58	21.66	21.68	23.11	23.11	23.28	20.68	20.58	20.64	
	1	0	24.18	24.21	24.34	21.78	21.73	21.79	23.03	23.26	23.24	21.00	20.76	20.90	
	1	49	24.26	24.30	24.57	21.86	21.90	21.92	23.42	23.31	23.57	21.24	20.72	21.09	
	1	99	24.11	24.15	24.36	21.70	21.67	21.87	23.26	23.23	23.46	21.00	20.70	20.88	
	50	0	23.01	23.08	23.16	20.65	20.58	20.57	22.08	22.08	22.17	19.76	19.57	19.51	
	50	24	23.10	23.13	23.24	20.59	20.59	20.60	22.08	22.07	22.31	19.83	19.58	19.64	
	50	49	23.06	23.09	23.21	20.55	20.55	20.66	22.09	22.07	22.28	19.72	19.57	19.63	
	100	0	23.06	23.12	23.25	20.57	20.57	20.62	22.08	22.07	22.28	19.73	19.58	19.63	
	1	0	21.13	21.16	21.27	18.75	18.77	18.68	19.97	20.25	20.20	17.78	17.77	17.53	
	1	49	21.14	21.19	21.31	18.71	18.74	18.77	20.21	20.14	20.37	17.86	17.70	17.60	
	1	99	21.14	21.22	21.37	18.67	18.76	18.83	20.24	20.27	20.51	17.81	17.81	17.76	
	50	0	20.95	21.02	21.10	18.65	18.56	18.56	20.03	20.02	20.14	17.74	17.56	17.51	
	50	24	21.02	21.10	21.21	18.59	18.58	18.59	20.03	20.01	20.26	17.81	17.57	17.64	
	50	49	21.00	21.07	21.18	18.55	18.56	18.68	20.08	20.00	20.27	17.74	17.57	17.65	
	100	0	21.02	21.08	21.20	18.57	18.56	18.60	20.01	20.00	20.23	17.73	17.56	17.63	

5G NR n7

Test Engineer ID:	12482	Test Date:	2024-02-22
--------------------------	-------	-------------------	------------

OUTPUT POWER FOR 5G NR n7 (5.0 MHz)

Bandwidth (MHz)	Modulation	RB Allocation	RB Offset	Conducted Average (dBm)											
				ANT 1			ANT 2			ANT 3			ANT 4		
				500500	507000	513500	500500	507000	513500	500500	507000	513500	500500	507000	513500
5.0	BPSK	1	0	25.44	25.51	25.54	23.42	23.63	23.38	24.57	24.85	24.66	22.59	22.47	22.54
		1	1	25.51	25.52	25.50	23.36	23.45	23.43	24.63	24.87	24.68	22.65	22.43	22.57
		1	23	25.44	25.58	25.40	23.56	23.59	23.45	24.90	24.92	24.62	22.70	22.46	22.58
		1	24	25.47	25.57	24.95	23.47	23.52	23.44	24.79	24.96	24.58	22.69	22.38	22.52
		12	6	25.50	25.48	25.40	23.51	23.51	23.40	24.67	24.85	24.60	22.66	22.43	22.56
	25	0	25.45	25.52	25.39	23.46	23.48	23.36	24.65	24.84	24.58	22.61	22.36	22.49	
	QPSK	1	0	24.43	24.85	24.21	22.56	23.25	22.85	24.11	24.90	24.60	21.76	22.46	22.41
		1	1	25.48	25.53	25.07	23.48	23.50	23.42	24.68	24.87	24.57	22.62	22.52	22.56
		1	23	25.58	25.63	24.60	23.45	23.70	23.25	24.99	25.00	24.60	22.66	22.54	22.44
		1	24	24.79	24.70	23.68	22.96	23.53	22.36	24.46	24.97	24.14	22.40	22.51	21.52
		12	6	25.57	25.57	25.30	23.43	23.54	23.42	24.71	24.90	24.59	22.60	22.42	22.58
	25	0	25.16	25.39	24.39	23.02	23.44	22.65	24.67	24.88	24.24	22.52	22.41	21.83	
	16QAM	1	0	23.54	24.04	23.41	21.31	22.49	21.91	23.00	23.46	23.59	20.93	21.49	21.46
		1	1	24.41	24.55	24.28	22.42	23.41	23.15	23.96	24.90	24.49	21.72	22.31	22.29
		1	23	24.95	24.92	23.77	22.74	23.64	22.36	24.53	24.79	23.93	22.37	22.48	21.91
		1	24	24.18	23.83	22.94	22.23	22.38	21.20	23.57	23.37	23.38	21.60	21.43	20.62
		12	6	25.43	25.70	24.62	23.38	23.57	23.06	24.59	25.00	24.62	22.55	22.44	22.12
	25	0	24.25	24.54	23.62	22.10	22.52	21.96	23.69	23.92	23.61	21.53	21.43	20.94	
	64QAM	1	0	22.92	23.17	22.99	21.17	21.90	21.43	22.57	23.49	23.23	20.20	20.89	20.20
		1	1	23.13	23.34	22.89	21.13	21.81	21.61	22.53	23.47	23.04	20.20	21.00	20.61
		1	23	23.43	23.30	22.37	21.55	21.86	21.28	23.00	23.50	22.55	20.91	21.00	20.00
		1	24	23.42	23.06	22.55	21.29	21.97	21.04	22.98	23.36	22.78	20.88	20.75	19.93
		12	6	23.90	23.93	23.19	21.66	22.08	21.81	23.07	23.37	23.10	21.06	20.99	20.74
	25	0	23.72	24.05	23.29	21.68	21.99	21.60	23.13	23.45	23.07	21.04	20.98	20.57	
	256QAM	1	0	21.44	21.88	21.56	19.44	19.83	19.58	20.87	21.45	20.82	18.74	18.93	18.32
		1	1	21.63	21.80	21.43	19.49	19.70	19.72	21.02	21.22	21.17	18.50	18.69	18.75
		1	23	21.93	22.15	21.30	20.06	19.98	19.67	21.33	21.55	21.06	18.90	18.76	18.63
		1	24	21.89	21.90	21.16	19.79	20.01	19.56	21.15	21.50	20.99	18.84	18.74	18.70
		12	6	21.92	22.00	21.77	19.97	20.06	19.87	21.07	21.30	21.00	19.06	18.94	18.65
	25	0	22.02	22.02	21.98	19.99	20.19	19.87	21.10	21.32	21.08	19.13	19.01	18.66	

OUTPUT POWER FOR 5G NR n7 (10.0 MHz)

Bandwidth (MHz)	Modulation	RB Allocation	RB Offset	Conducted Average (dBm)											
				ANT 1			ANT 2			ANT 3			ANT 4		
				501000	507000	513000	501000	507000	513000	501000	507000	513000	501000	507000	513000
10.0	BPSK	1	0	25.63	25.62	25.63	23.63	23.66	23.41	24.43	24.83	24.62	22.22	22.62	22.62
		1	1	25.67	25.62	25.69	23.48	23.70	23.53	24.54	24.90	24.62	22.35	22.58	22.52
		1	50	25.70	25.66	25.57	23.57	23.69	23.46	24.87	24.83	24.53	22.54	22.56	22.57
		1	51	25.70	25.69	25.11	23.57	23.57	23.50	24.91	24.87	24.68	22.48	22.47	22.53
		12	6	25.65	25.51	25.55	23.49	23.54	23.44	24.67	24.78	24.47	22.39	22.45	22.49
	50	0	25.65	25.61	25.55	23.53	23.60	23.50	24.72	24.82	24.55	22.44	22.50	22.52	
	QPSK	1	0	24.60	24.94	24.72	22.64	23.01	22.85	23.97	24.77	24.62	21.56	22.51	22.57
		1	1	25.51	25.58	25.59	23.51	23.59	23.51	24.45	24.90	24.69	22.27	22.57	22.67
		1	50	25.52	25.62	24.75	23.59	23.66	23.32	24.94	24.83	24.61	22.54	22.54	22.47
		1	51	24.57	24.64	23.77	23.45	23.57	22.51	24.70	25.00	24.06	22.50	22.52	21.68
		12	6	25.67	25.57	25.62	23.53	23.60	23.48	24.72	24.87	24.65	22.34	22.46	22.47
	50	0	25.16	25.28	24.79	23.21	23.31	22.92	24.71	24.87	24.59	22.36	22.46	22.47	
	16QAM	1	0	23.65	24.10	23.98	21.93	21.75	21.85	23.09	23.88	23.31	20.47	21.61	21.32
		1	1	24.50	25.02	24.87	22.95	23.10	22.90	23.83	24.54	24.68	21.30	22.70	22.65
		1	50	24.35	24.48	23.75	23.70	23.46	22.50	24.71	24.86	24.29	22.43	22.33	21.79
		1	51	23.42	23.79	22.80	22.52	22.65	21.51	23.65	23.95	23.15	21.27	21.76	20.65
		12	6	25.56	25.65	25.27	23.50	23.52	23.44	24.72	24.89	24.65	22.39	22.43	22.49
	50	0	24.44	24.66	24.14	22.46	22.53	22.24	23.76	23.89	23.70	21.35	21.46	21.54	
	64QAM	1	0	22.79	23.45	23.46	21.13	21.52	21.23	22.30	23.33	23.28	19.89	20.99	20.88
		1	1	23.12	23.45	23.49	21.13	21.50	21.43	22.51	23.28	23.32	19.88	20.84	20.95
		1	50	23.03	23.16	22.52	22.09	22.02	21.32	23.01	23.27	22.93	20.91	20.90	20.51
		1	51	23.35	23.23	22.63	21.90	21.78	21.28	23.09	23.43	22.73	20.88	20.89	20.50
		12	6	24.07	24.19	24.02	22.05	22.19	21.99	23.21	23.39	23.18	20.81	20.97	20.97
	50	0	23.92	24.15	23.70	22.00	22.03	21.77	23.21	23.34	23.11	21.12	20.91	20.99	
	256QAM	1	0	21.45	22.27	21.96	19.45	19.87	19.68	20.90	21.24	20.98	18.62	18.52	18.78
		1	1	21.69	21.94	21.98	19.47	19.98	19.83	21.02	21.32	21.08	18.95	18.91	18.76
		1	50	22.19	22.26	21.44	19.84	19.81	19.80	21.31	21.51	21.34	18.94	18.86	18.81
		1	51	22.02	22.15	21.21	19.94	19.70	19.89	21.31	21.23	21.02	18.98	18.78	18.78
		12	6	22.03	22.14	22.15	20.13	20.20	19.95	21.12	21.25	21.04	19.11	18.97	19.10
	50	0	21.96	22.09	22.01	20.08	20.13	19.92	21.08	21.27	21.08	19.19	18.97	19.04	

OUTPUT POWER FOR 5G NR n7 (15.0 MHz)

Bandwidth (MHz)	Modulation	RB Allocation	RB Offset	Conducted Average (dBm)											
				ANT 1			ANT 2			ANT 3			ANT 4		
				501500	507000	512500	501500	507000	512500	501500	507000	512500	501500	507000	512500
15.0	BPSK	1	0	25.54	25.66	25.56	23.61	23.55	23.70	24.45	24.48	24.69	22.46	22.52	22.46
		1	1	25.63	25.58	25.70	23.42	23.67	23.64	24.51	24.80	24.62	22.56	22.53	22.52
		1	77	25.59	25.70	25.36	23.58	23.65	23.49	24.78	24.67	24.38	22.67	22.51	22.40
		1	78	25.55	25.62	24.90	23.62	23.57	23.51	24.77	24.61	24.45	22.66	22.43	22.40
		36	18	25.36	25.54	25.52	23.41	23.49	23.44	24.60	24.72	24.33	22.55	22.29	22.34
		75	0	25.38	25.57	25.54	23.49	23.59	23.52	24.64	24.72	24.43	22.62	22.39	22.40
		1	0	24.24	24.70	24.29	22.57	22.66	22.37	23.70	24.41	24.01	21.67	22.21	21.54
		1	1	25.26	25.68	25.32	23.47	23.57	23.31	24.46	25.00	24.48	22.56	22.52	22.17
		1	77	25.10	25.24	24.51	23.64	23.68	23.29	24.75	24.80	24.54	22.66	22.48	21.96
		1	78	24.06	24.32	23.51	23.20	23.37	22.38	24.10	24.23	23.70	22.43	22.40	21.05
		36	18	25.39	25.59	25.54	23.48	23.53	23.57	24.64	24.71	24.47	22.66	22.37	22.09
		75	0	24.90	25.02	24.64	23.20	23.20	22.73	24.43	24.69	24.38	22.53	22.40	21.90
	1	0	23.45	23.47	23.66	21.66	21.75	21.03	22.62	23.16	23.02	20.70	21.12	20.28	
	1	1	24.46	24.80	24.52	22.45	22.71	22.24	23.56	24.31	24.18	21.55	22.22	21.34	
	1	77	24.21	24.42	23.85	23.17	23.39	22.56	24.06	24.28	23.71	22.60	22.63	21.29	
	1	78	23.30	23.43	23.13	22.48	22.49	21.37	23.32	23.49	22.45	21.47	21.50	20.12	
	36	18	25.22	25.50	25.20	23.57	23.42	23.27	24.69	24.76	24.42	22.70	22.46	22.07	
	75	0	24.30	24.38	23.90	22.48	22.33	22.01	23.64	23.76	23.41	21.66	21.43	21.09	
	1	0	22.67	23.16	22.95	20.63	21.29	20.78	22.33	22.84	22.59	20.06	20.86	19.79	
	1	1	22.95	23.27	22.91	21.00	21.21	20.97	22.50	22.85	22.50	20.33	20.72	20.10	
	1	77	22.97	22.90	22.47	21.64	22.08	21.37	22.91	22.82	22.46	21.07	20.86	19.91	
	1	78	22.66	23.14	22.10	21.72	21.94	21.06	22.62	22.71	22.27	21.04	20.85	19.82	
	36	18	23.95	23.96	23.82	21.97	21.98	21.88	23.20	23.25	22.92	21.08	20.90	20.60	
	75	0	23.65	23.85	23.50	21.99	21.98	21.57	23.14	23.25	22.86	21.09	20.91	20.63	
	1	0	21.44	21.67	21.39	19.44	19.54	19.32	20.59	21.18	20.86	18.33	18.78	18.34	
	1	1	21.38	21.78	21.43	19.55	19.60	19.34	20.52	21.17	21.01	18.60	18.76	18.06	
	1	77	21.65	21.73	21.22	20.07	19.75	19.91	21.10	21.12	20.74	18.90	18.46	18.61	
	1	78	21.63	21.85	20.91	19.90	19.88	19.92	21.22	21.21	20.89	18.89	18.72	18.28	
	36	18	21.98	22.16	21.96	19.97	20.06	20.04	21.04	21.13	20.94	19.06	18.82	18.56	
	75	0	21.92	22.09	21.97	19.91	20.06	20.05	21.08	21.21	20.97	19.08	18.85	18.60	

OUTPUT POWER FOR 5G NR n7 (20.0 MHz)

Bandwidth (MHz)	Modulation	RB Allocation	RB Offset	Conducted Average (dBm)											
				ANT 1			ANT 2			ANT 3			ANT 4		
				502000	507000	512000	502000	507000	512000	502000	507000	512000	502000	507000	512000
20.0	BPSK	1	0	25.56	25.58	25.60	23.59	23.43	23.15	24.52	24.94	24.63	22.45	22.56	22.53
		1	1	25.61	25.68	25.70	23.56	23.59	23.59	24.55	24.86	24.73	22.60	22.57	22.53
		1	104	25.58	25.63	25.43	23.70	23.68	23.48	24.99	24.69	24.52	22.70	22.46	22.38
		1	105	25.62	25.41	24.90	23.49	23.61	23.02	25.00	24.70	24.43	22.65	22.50	22.28
		50	25	25.57	25.59	25.63	23.64	23.58	23.57	24.80	24.83	24.51	22.57	22.45	22.43
		100	0	25.56	25.57	25.58	23.64	23.60	23.40	24.81	24.83	24.53	22.55	22.46	22.42
		1	0	24.47	24.27	23.98	21.93	21.87	21.60	23.76	24.22	23.59	21.46	21.97	21.55
		1	1	25.40	25.32	25.04	22.88	22.94	22.59	24.50	24.94	24.52	22.46	22.52	22.48
		1	104	25.10	24.93	24.52	22.92	23.17	22.71	24.89	24.72	24.44	22.59	22.46	22.21
		1	105	24.17	23.99	23.69	21.98	22.25	21.87	23.88	23.92	23.80	21.80	22.29	21.39
		50	25	25.65	25.62	25.65	23.64	23.58	23.61	24.86	24.87	24.54	22.59	22.47	22.47
		100	0	25.01	24.98	24.49	22.95	22.88	22.29	24.42	24.83	24.20	22.52	22.45	22.04
	1	0	23.51	23.28	23.17	21.29	21.37	20.65	22.89	23.26	22.87	20.30	21.03	20.68	
	1	1	24.39	24.78	24.21	22.20	21.93	22.18	24.03	24.40	23.31	21.50	22.43	21.57	
	1	104	24.34	23.89	23.90	22.28	22.28	22.29	23.82	23.93	24.16	21.80	21.95	21.54	
	1	105	23.53	23.07	22.71	21.43	21.51	21.02	23.06	23.00	22.77	21.18	21.43	20.63	
	50	25	25.47	25.50	25.26	23.39	23.28	22.85	24.84	24.87	24.49	22.57	22.42	22.45	
	100	0	24.19	24.24	23.91	22.17	22.14	21.62	23.80	23.86	23.50	21.53	21.40	21.23	
	1	0	22.83	22.90	22.53	20.68	20.57	20.17	22.38	22.49	22.24	20.01	20.44	20.33	
	1	1	22.84	23.03	22.80	20.79	20.65	20.32	21.90	22.97	22.30	20.03	20.67	20.46	
	1	104	23.01	22.50	22.45	20.83	21.30	20.67	22.84	22.79	22.40	20.60	20.72	20.17	
	1	105	22.86	22.76	22.44	20.73	21.04	20.86	22.52	22.67	22.42	20.31	20.68	20.12	
	50	25	23.97	23.94	23.78	21.88	21.63	21.29	23.27	23.35	23.08	21.13	20.92	20.87	
	100	0	23.74	23.78	23.50	21.64	21.60	21.16	23.24	23.33	22.99	21.09	20.91	20.74	
	1	0	21.38	21.27	20.98	18.79	19.04	18.69	20.72	21.06	20.57	18.32	18.96	18.23	
	1	1	21.48	21.51	21.16	18.87	19.08	18.72	20.38	21.18	20.38	18.39	18.81	18.70	
	1	104	21.19	21.40	21.14	19.17	19.45	19.24	21.11	21.15	20.97	18.89	18.95	18.55	
	1	105	21.42	21.25	20.95	19.04	19.36	19.39	20.99	21.16	20.77	19.11	18.76	18.63	
	50	25	21.90	22.05	21.98	20.03	20.14	19.81	21.17	21.25	21.05	19.12	18.91	18.90	
	100	0	21.95	22.09	21.98	20.06	20.07	19.77	21.18	21.29	21.03	19.08	18.90	18.86	

OUTPUT POWER FOR 5G NR n7 (25.0 MHz)

Bandwidth (MHz)	Modulation	RB Allocation	RB Offset	Conducted Average (dBm)											
				ANT 1			ANT 2			ANT 3			ANT 4		
				502500	507000	511500	502500	507000	511500	502500	507000	511500	502500	507000	511500
25.0	BPSK	1	0	25.60	25.65	25.63	23.36	23.34	23.53	24.61	24.94	24.70	22.61	22.61	22.48
		1	1	25.64	25.56	25.59	23.70	23.50	23.54	24.63	25.00	24.73	22.52	22.66	22.56
		1	131	25.62	25.55	25.02	23.57	23.59	23.41	24.89	24.91	24.47	22.70	22.46	22.46
		1	132	25.56	25.59	24.52	23.20	23.35	22.93	24.89	24.86	24.53	22.60	22.54	22.51
		64	32	25.52	25.66	25.53	23.53	23.45	23.48	24.77	24.79	24.51	22.62	22.41	22.48
		128	0	25.56	25.63	25.49	23.55	23.43	23.48	24.72	24.73	24.52	22.52	22.47	22.43
	QPSK	1	0	24.48	24.78	24.03	21.80	21.73	21.89	23.68	24.10	23.91	21.53	21.94	22.11
		1	1	25.45	25.58	24.97	22.67	22.79	22.96	24.53	24.77	24.90	22.59	22.61	22.55
		1	131	25.70	25.04	24.06	22.71	22.88	22.61	24.99	24.64	24.51	22.70	22.53	22.24
		1	132	24.82	24.11	23.21	21.83	21.81	21.70	24.04	23.74	23.78	21.97	22.04	21.37
		64	32	25.54	25.64	25.55	23.55	23.44	23.25	24.71	24.79	24.51	22.67	22.46	22.49
		128	0	24.85	24.97	24.42	22.86	22.72	22.30	24.52	24.78	24.27	22.43	22.51	21.93
	16QAM	1	0	23.80	23.85	23.34	20.81	20.90	21.00	22.60	23.26	22.96	20.64	20.69	21.45
		1	1	24.49	24.81	24.56	21.73	21.62	22.25	23.95	23.75	23.63	21.61	22.13	22.14
		1	131	25.15	24.38	23.58	22.07	21.53	21.62	24.04	24.05	23.57	21.77	22.32	21.59
		1	132	23.78	23.42	22.45	21.14	20.89	20.79	23.14	22.54	22.87	21.24	21.15	20.52
		64	32	25.25	25.34	24.94	23.20	23.11	22.60	24.73	24.69	24.45	22.67	22.35	22.42
		128	0	24.04	24.24	23.88	22.06	21.94	21.60	23.79	23.70	23.46	21.56	21.52	21.33
	64QAM	1	0	23.06	23.24	22.95	20.57	20.70	20.61	22.23	22.50	22.40	19.91	20.50	20.74
		1	1	22.92	23.69	22.87	20.34	20.60	20.95	22.41	22.55	22.65	19.92	20.36	20.87
		1	131	23.53	22.71	22.15	20.64	20.55	20.54	22.69	22.43	22.52	20.72	20.66	20.47
		1	132	23.40	22.74	22.08	20.57	20.65	20.58	22.60	22.56	22.37	20.47	20.55	20.17
		64	32	23.80	23.96	23.52	21.78	21.66	21.13	23.25	23.35	23.03	21.09	21.08	20.94
		128	0	23.68	23.79	23.53	21.54	21.51	21.12	23.28	23.21	23.01	20.95	20.99	20.91
	256QAM	1	0	21.29	22.03	20.98	18.14	18.55	18.97	20.80	20.97	20.58	18.33	18.93	18.89
		1	1	21.54	22.10	21.35	18.70	18.78	18.95	20.72	20.87	20.88	18.23	18.94	19.00
		1	131	22.13	21.24	20.67	18.97	19.13	19.01	20.95	21.09	20.86	18.90	18.59	18.60
		1	132	22.20	21.49	20.78	18.85	19.16	19.03	21.35	21.00	20.90	19.01	18.93	18.84
		64	32	21.94	22.01	22.01	20.08	19.89	19.65	21.24	21.23	20.95	19.06	18.98	19.00
		128	0	21.98	22.04	22.06	20.05	19.98	19.63	21.24	21.25	21.03	19.06	18.95	18.98

OUTPUT POWER FOR 5G NR n7 (30.0 MHz)

Bandwidth (MHz)	Modulation	RB Allocation	RB Offset	Conducted Average (dBm)											
				ANT 1			ANT 2			ANT 3			ANT 4		
				503000	507000	511000	503000	507000	511000	503000	507000	511000	503000	507000	511000
30.0	BPSK	1	0	25.52	25.63	25.57	23.30	23.43	23.47	24.54	24.92	24.75	22.66	22.70	22.56
		1	1	25.50	25.66	25.63	23.67	23.70	23.56	24.60	24.95	24.87	22.54	22.66	22.48
		1	158	25.55	25.70	25.21	23.65	23.53	23.44	24.81	24.57	24.49	22.58	22.58	22.38
		1	159	25.52	25.37	24.62	23.46	23.10	22.95	24.85	24.66	24.48	22.56	22.52	22.35
		80	40	25.51	25.57	25.52	23.59	23.47	23.51	24.70	24.70	24.53	22.59	22.43	22.44
		160	0	25.55	25.65	25.02	23.62	23.54	23.04	24.82	24.74	24.57	22.58	22.55	22.45
	QPSK	1	0	24.50	24.85	24.90	21.79	21.89	22.56	23.80	23.94	24.45	21.51	21.84	22.57
		1	1	25.50	25.60	25.70	22.79	22.77	23.51	24.49	24.86	24.73	22.51	22.57	22.59
		1	158	25.61	24.80	24.21	22.96	22.63	22.64	25.00	24.58	24.47	22.66	22.54	22.28
		1	159	24.85	23.97	23.17	21.93	21.79	21.64	24.43	23.51	23.78	22.27	21.72	21.37
		80	40	25.52	25.59	25.54	23.61	23.47	23.34	24.69	24.70	24.49	22.62	22.44	22.48
		160	0	24.81	24.79	24.47	22.80	22.67	22.28	24.48	24.59	24.12	22.33	22.54	21.92
	16QAM	1	0	23.43	23.72	23.73	20.59	20.33	21.63	22.82	23.33	23.49	20.43	21.04	21.76
		1	1	24.48	25.04	24.96	21.83	22.15	22.44	23.71	24.24	24.35	21.81	21.36	22.53
		1	158	24.76	23.85	23.19	22.42	21.62	21.77	24.65	23.89	23.99	22.28	21.68	21.44
		1	159	23.97	22.94	22.38	20.71	20.72	20.90	23.66	22.31	22.80	21.43	20.42	20.25
		80	40	25.04	25.34	24.83	22.99	23.15	22.53	24.82	24.78	24.46	22.44	22.42	22.26
		160	0	24.10	24.09	23.72	22.01	21.89	21.61	23.69	23.69	23.50	21.57	21.52	21.27
	64QAM	1	0	22.89	23.30	23.19	20.36	20.67	21.16	22.39	22.68	23.14	19.97	20.44	21.06
		1	1	23.29	23.31	23.38	20.48	20.73	21.19	22.17	22.48	23.23	20.21	20.55	20.78
		1	158	23.29	22.68	21.79	21.06	20.62	20.60	23.00	22.19	22.41	20.83	20.20	20.17
		1	159	23.44	22.44	21.92	20.59	20.51	20.58	23.07	22.35	22.44	20.91	20.23	19.94
		80	40	23.63	23.97	23.50	21.64	21.63	21.20	23.34	23.34	23.14	21.09	20.95	20.82
		160	0	23.64	23.55	23.37	21.50	21.45	21.17	23.33	23.25	23.16	20.91	21.08	20.93
	256QAM	1	0	21.38	22.10	21.92	18.74	18.96	19.43	20.59	20.69	21.19	18.51	18.71	18.65
		1	1	21.50	21.96	21.88	18.97	18.76	19.69	20.54	20.70	21.08	18.25	18.79	19.13
		1	158	21.84	21.03	20.73	19.18	19.01	18.82	21.41	20.65	20.98	18.93	18.67	18.64
		1	159	22.42	21.72	20.85	19.17	18.85	19.22	21.24	20.62	20.85	18.99	18.55	18.82
		80	40	21.88	21.98	21.94	20.07	20.01	19.65	21.20	21.17	21.00	19.12	18.94	18.89
		160	0	21.92	22.00	22.01	19.95	19.96	19.85	21.25	21.25	21.06	19.18	18.97	18.96

OUTPUT POWER FOR 5G NR n7 (35.0 MHz)

Bandwidth (MHz)	Modulation	RB Allocation	RB Offset	Conducted Average (dBm)											
				ANT 1			ANT 2			ANT 3			ANT 4		
				50.5	507000	510500	50.5	507000	510500	50.5	507000	510500	50.5	507000	510500
35.0	BPSK	1	0	25.36	25.31	25.55	23.38	23.44	23.50	24.21	24.79	24.98	22.48	22.70	22.52
		1	1	25.46	25.40	25.48	23.39	23.32	23.54	24.15	24.80	24.85	22.47	22.64	22.54
		1	186	25.45	25.48	25.51	23.43	23.44	23.62	24.85	24.91	24.80	22.46	22.59	22.49
		1	187	25.43	25.50	25.40	23.43	23.40	23.70	24.95	24.81	24.69	22.52	22.57	22.54
		90	45	25.38	25.34	25.41	23.35	23.44	23.31	24.64	24.81	24.74	22.48	22.44	22.53
		180	0	25.43	25.36	25.46	23.28	23.44	23.33	24.64	24.85	24.76	22.55	22.46	22.57
	QPSK	1	0	25.33	25.31	25.49	22.86	23.49	23.57	24.08	24.84	24.96	21.45	22.49	22.45
		1	1	25.43	25.42	25.53	23.43	23.51	23.58	24.20	24.84	24.82	22.44	22.65	22.40
		1	186	25.47	25.56	25.34	23.34	23.24	23.70	25.00	24.90	24.76	22.43	22.69	22.53
		1	187	25.70	25.50	24.82	23.48	23.09	22.81	24.91	24.89	24.56	22.45	22.09	21.72
		90	45	25.44	25.33	25.46	23.35	23.49	23.35	24.66	24.90	24.80	22.58	22.47	22.54
		180	0	25.36	25.46	25.48	23.36	23.47	23.37	24.67	24.90	24.83	22.56	22.48	22.57
	16QAM	1	0	24.26	24.06	24.28	22.08	22.33	22.09	23.24	23.59	23.52	20.51	21.49	21.52
		1	1	25.30	25.41	25.53	23.12	23.54	23.48	24.33	24.69	25.00	21.55	22.59	22.57
		1	186	25.57	25.47	24.94	23.64	23.18	23.11	24.58	24.99	24.85	21.92	22.14	21.61
		1	187	24.52	24.46	23.80	22.54	22.10	21.66	23.89	23.73	23.88	21.31	21.23	21.19
		90	45	25.49	25.45	25.39	23.39	23.48	23.33	24.68	24.91	24.80	22.50	22.47	22.50
		180	0	24.47	24.47	24.43	22.43	22.49	22.32	23.68	23.85	23.84	21.58	21.48	21.56
	64QAM	1	0	23.77	24.09	24.01	21.43	22.01	21.95	22.73	23.39	23.59	19.98	21.24	20.87
		1	1	23.91	24.16	23.73	21.25	22.06	22.03	22.54	23.38	23.43	20.08	21.10	21.20
		1	186	24.17	24.29	23.70	21.92	22.00	21.94	23.59	23.35	23.11	20.90	20.53	20.52
		1	187	24.05	24.32	23.51	21.93	21.62	21.51	23.27	23.20	23.45	20.93	20.78	20.31
		90	45	23.86	23.94	23.91	21.90	21.97	21.74	23.21	23.35	23.29	21.02	20.97	21.05
		180	0	23.89	23.94	23.96	21.93	21.94	21.91	23.16	23.38	23.29	21.07	21.03	21.04
	256QAM	1	0	21.95	22.01	21.84	19.75	19.91	19.78	20.69	21.21	21.31	18.14	19.01	18.83
		1	1	21.98	21.86	22.21	19.94	20.13	19.81	20.90	21.32	21.48	18.25	18.87	19.06
		1	186	21.82	22.00	22.02	19.96	19.73	19.99	21.56	21.55	21.05	19.13	19.15	18.93
		1	187	21.80	22.24	21.72	19.74	19.94	20.06	21.50	21.48	21.25	19.16	19.03	19.02
		90	45	21.72	21.91	21.92	19.85	19.89	19.79	21.12	21.28	21.24	19.02	18.94	18.94
		180	0	21.77	21.93	21.88	19.86	19.91	19.84	21.18	21.27	21.28	18.94	19.05	18.98

OUTPUT POWER FOR 5G NR n7 (40.0 MHz)

Bandwidth (MHz)	Modulation	RB Allocation	RB Offset	Conducted Average (dBm)											
				ANT 1			ANT 2			ANT 3			ANT 4		
				504000	507000	510000	504000	507000	510000	504000	507000	510000	504000	507000	510000
40.0	BPSK	1	0	25.06	25.23	25.07	23.59	23.60	23.51	24.62	24.90	24.91	22.29	22.70	22.28
		1	1	25.15	25.16	25.11	23.53	23.56	23.46	24.60	24.86	24.91	22.16	22.45	22.40
		1	214	25.11	25.14	24.98	23.44	23.42	23.42	24.72	24.68	24.49	22.30	22.26	22.24
		1	215	25.05	25.70	25.02	23.48	23.37	23.42	24.74	24.78	24.49	22.28	22.27	22.24
		108	54	24.97	25.07	25.13	23.45	23.36	23.31	24.84	24.79	24.62	22.37	22.26	22.23
		216	0	25.06	25.09	25.13	23.48	23.41	23.35	24.85	24.81	24.67	22.38	22.26	22.26
	QPSK	1	0	25.13	25.15	25.19	22.87	23.49	23.44	24.72	25.00	25.00	22.27	22.36	22.34
		1	1	25.05	25.18	25.12	23.54	23.70	23.45	24.56	24.98	24.94	22.24	22.37	22.37
		1	214	25.22	25.23	25.04	23.51	23.54	23.38	24.78	24.84	24.57	22.14	22.31	22.27
		1	215	25.14	24.59	24.10	23.46	22.76	22.82	24.77	24.65	24.54	22.30	22.25	21.93
		108	54	25.08	25.13	25.17	23.47	23.30	23.41	24.92	24.87	24.67	22.43	22.33	22.22
		216	0	25.08	25.15	25.12	23.53	23.47	23.43	24.89	24.88	24.73	22.42	22.33	22.25
	16QAM	1	0	24.08	24.12	24.30	22.41	22.71	22.34	23.65	24.04	24.02	21.50	21.48	21.56
		1	1	25.00	24.92	25.00	23.22	23.23	23.53	24.34	24.77	24.74	22.11	22.39	22.17
		1	214	25.60	24.84	24.31	22.99	22.29	22.49	24.92	24.67	24.27	22.40	22.28	21.84
		1	215	24.15	23.79	23.30	22.48	21.22	21.81	23.56	23.72	23.54	21.26	21.31	21.31
		108	54	25.02	25.17	25.15	23.51	23.47	23.43	24.88	24.84	24.62	22.38	22.29	22.18
		216	0	24.01	24.15	24.15	22.47	22.46	22.38	23.86	23.84	23.70	21.42	21.35	21.22
	64QAM	1	0	23.46	23.72	23.66	21.77	22.22	22.13	22.65	23.39	23.38	20.66	20.90	20.77
		1	1	23.37	23.31	23.88	21.81	21.97	22.13	22.98	23.23	23.52	20.62	20.72	21.08
		1	214	23.80	23.28	22.83	22.33	21.56	21.83	23.32	23.12	22.88	20.78	20.67	20.58
		1	215	23.47	23.05	22.89	22.19	21.64	21.75	23.07	23.15	23.04	20.85	20.83	20.66
		108	54	23.57	23.52	23.61	21.91	21.92	21.85	23.37	23.39	23.14	20.90	20.80	20.73
		216	0	23.54	23.50	23.63	21.93	21.95	21.86	23.31	23.25	23.16	20.93	20.87	20.75
	256QAM	1	0	21.56	21.42	21.56	19.70	20.08	20.12	21.05	21.40	21.22	18.90	18.74	18.76
		1	1	21.69	21.64	21.57	19.56	20.18	20.06	21.03	21.35	21.32	18.69	18.85	18.97
		1	214	21.59	21.59	21.59	20.03	19.85	20.17	21.32	20.95	21.19	18.63	18.73	18.84
		1	215	21.72	21.67	21.66	19.88	19.69	20.08	21.33	21.10	21.07	18.82	18.76	18.53
		108	54	21.52	21.52	21.59	19.90	19.88	19.87	21.30	21.36	21.14	18.82	18.71	18.68
		216	0	21.57	21.54	21.61	19.94	19.88	19.92	21.25	21.29	21.11	18.88	18.85	18.68

8.2. LTE BAND 12 AND 5G NR n12

LTE BAND 12

Test Engineer ID:	12482	Test Date:	2024-03-01
-------------------	-------	------------	------------

OUTPUT POWER FOR LTE BAND 12 (1.4 MHz)

Bandwidth (MHz)	Modulation	RB Allocation	RB Offset	Conducted Average (dBm)					
				ANT 1			ANT 2		
				23017	23095	23173	23017	23095	23173
1.4	QPSK	1	0	25.46	25.49	25.64	25.03	25.15	25.07
		1	2	25.54	25.56	25.69	25.05	25.20	25.11
		1	5	25.48	25.53	25.65	25.01	25.20	25.11
		3	0	25.46	25.51	25.64	25.02	25.11	25.07
		3	1	25.47	25.53	25.70	24.99	25.10	25.11
		3	2	25.48	25.55	25.67	25.01	25.11	25.10
	16QAM	6	0	25.05	25.12	25.28	24.08	24.13	24.22
		1	0	25.18	25.29	25.18	24.28	24.35	24.32
		1	2	25.26	25.33	25.33	24.28	24.41	24.32
		1	5	25.27	25.36	25.46	24.29	24.57	24.53
		3	0	25.14	25.26	25.26	24.19	24.34	24.32
		3	1	25.19	25.25	25.37	24.19	24.36	24.32
	64QAM	3	2	25.19	25.26	25.36	24.19	24.36	24.32
		6	0	24.12	24.16	24.35	23.11	23.19	23.20
		1	0	24.46	24.46	24.38	23.42	23.34	23.31
		1	2	24.47	24.50	24.50	23.40	23.43	23.36
		1	5	24.40	24.50	24.55	23.43	23.39	23.37
		3	0	24.19	24.29	24.30	23.25	23.32	23.31
	256QAM	3	1	24.20	24.33	24.41	23.30	23.34	23.34
		3	2	24.24	24.32	24.45	23.24	23.36	23.33
		6	0	23.04	23.27	23.27	22.18	22.23	22.21
		1	0	21.09	21.16	21.26	20.18	20.25	20.17
		1	2	21.23	21.30	21.39	20.29	20.39	20.31
		1	5	21.13	21.23	21.35	20.27	20.35	20.23
256QAM	3	0	21.04	21.08	21.09	20.22	20.20	20.19	
	3	1	21.04	21.10	21.16	20.21	20.22	20.28	
	3	2	21.06	21.18	21.23	20.23	20.31	20.25	
	6	0	21.01	21.13	21.16	20.10	20.17	20.20	

OUTPUT POWER FOR LTE BAND 12 (3.0 MHz)

Bandwidth (MHz)	Modulation	RB Allocation	RB Offset	Conducted Average (dBm)					
				ANT 1			ANT 2		
				23025	23095	23165	23025	23095	23165
3.0	QPSK	1	0	25.51	25.55	25.35	24.97	25.03	24.94
		1	7	25.60	25.67	25.70	25.09	25.20	25.17
		1	14	25.49	25.56	25.70	24.98	25.03	25.04
		8	0	25.12	25.17	24.56	24.07	24.15	24.15
		8	4	25.23	25.20	24.86	24.18	24.20	24.18
		8	7	25.22	25.27	24.99	24.16	24.26	24.24
	16QAM	15	0	25.18	25.25	24.80	24.13	24.15	24.13
		1	0	25.20	25.39	24.55	24.24	24.36	24.11
		1	7	25.29	25.45	24.95	24.37	24.40	24.42
		1	14	25.24	25.33	25.24	24.19	24.32	24.28
		8	0	24.14	24.25	23.60	23.05	23.20	23.18
		8	4	24.26	24.26	23.91	23.19	23.22	23.20
	64QAM	8	7	24.27	24.34	24.14	23.18	23.32	23.29
		15	0	24.19	24.26	23.93	23.16	23.18	23.13
		1	0	24.44	24.50	23.84	23.45	23.52	23.31
		1	7	24.53	24.56	24.25	23.48	23.47	23.62
		1	14	24.40	24.46	24.49	23.30	23.52	23.55
		8	0	23.16	23.23	22.64	22.15	22.18	22.14
	256QAM	8	4	23.28	23.24	22.99	22.27	22.21	22.19
		8	7	23.28	23.30	23.17	22.25	22.29	22.25
		15	0	23.20	23.27	22.92	22.20	22.20	22.19
		1	0	21.21	21.27	20.92	20.19	20.14	20.26
		1	7	21.35	21.47	21.19	20.27	20.33	20.29
		1	14	21.28	21.36	21.24	20.24	20.30	20.21
256QAM	8	0	21.14	21.19	20.48	20.11	20.17	20.16	
	8	4	21.24	21.22	20.84	20.21	20.25	20.22	
	8	7	21.24	21.30	21.04	20.19	20.30	20.31	
	15	0	21.17	21.25	20.84	20.18	20.16	20.14	

OUTPUT POWER FOR LTE BAND 12 (5.0 MHz)

Bandwidth (MHz)	Modulation	RB Allocation	RB Offset	Conducted Average (dBm)					
				ANT 1			ANT 2		
				23035 701.5	23095 707.5	23155 713.5	23035 701.5	23095 707.5	23155 713.5
5.0	QPSK	1	0	25.53	25.56	25.35	24.98	25.07	24.51
		1	12	25.63	25.66	25.14	25.09	25.20	24.88
		1	24	25.51	25.59	25.70	24.99	25.02	25.07
		12	0	25.07	25.16	24.21	24.08	24.17	23.43
		12	6	25.18	25.18	24.27	24.17	24.22	23.84
		12	11	25.15	25.23	24.70	24.16	24.26	24.21
		25	0	25.17	25.24	24.37	24.17	24.16	23.91
	16QAM	1	0	25.14	25.23	24.54	24.25	24.40	23.76
		1	12	25.30	25.40	24.27	24.41	24.52	24.15
		1	24	25.15	25.19	24.85	24.32	24.28	24.39
		12	0	24.09	24.10	23.22	23.05	23.13	22.82
		12	6	24.19	24.12	23.34	23.15	23.16	23.23
		12	11	24.18	24.17	23.73	23.13	23.21	23.42
		25	0	24.17	24.23	23.53	23.17	23.17	23.07
	64QAM	1	0	24.43	24.42	23.76	23.32	23.41	23.02
		1	12	24.51	24.51	23.45	23.44	23.45	23.17
		1	24	24.38	24.47	23.89	23.37	23.29	23.40
		12	0	23.13	23.25	22.48	22.10	22.23	21.68
		12	6	23.25	23.27	22.54	22.21	22.24	22.07
		12	11	23.21	23.32	22.91	22.17	22.29	22.36
		25	0	23.17	23.24	22.60	22.15	22.15	22.07
	256QAM	1	0	21.18	21.26	20.92	20.24	20.21	20.14
		1	12	21.36	21.42	20.56	20.40	20.37	20.16
		1	24	21.26	21.32	20.60	20.27	20.32	20.30
		12	0	21.08	21.14	20.41	20.09	20.17	19.62
12		6	21.19	21.20	20.38	20.19	20.20	20.00	
12		11	21.17	21.23	20.77	20.16	20.25	20.23	
25		0	21.19	21.24	20.52	20.15	20.17	20.06	

OUTPUT POWER FOR LTE BAND 12 (10.0 MHz)

Bandwidth (MHz)	Modulation	RB Allocation	RB Offset	Conducted Average (dBm)					
				ANT 1			ANT 2		
				23060 704.0	23095 707.5	23130 711.0	23060 704.0	23095 707.5	23130 711.0
10.0	QPSK	1	0	25.58	25.58	25.68	25.10	25.08	25.17
		1	24	25.60	25.69	25.47	25.15	25.20	24.58
		1	49	25.65	25.16	25.70	25.14	24.50	25.05
		25	0	25.17	25.22	25.31	24.18	24.24	24.21
		25	12	25.29	25.23	24.69	24.27	24.24	23.69
		25	24	25.25	25.16	24.40	24.24	24.09	23.89
		50	0	25.24	25.22	24.90	24.25	24.23	23.93
	16QAM	1	0	25.36	25.36	25.49	24.29	24.36	24.43
		1	24	25.35	25.45	24.64	24.40	24.45	23.61
		1	49	25.41	24.24	24.78	24.43	23.57	24.17
		25	0	24.19	24.22	24.34	23.18	23.23	23.24
		25	12	24.29	24.25	23.96	23.29	23.26	22.90
		25	24	24.26	24.31	23.59	23.29	23.25	22.97
		50	0	24.25	24.23	24.12	23.26	23.22	23.19
	64QAM	1	0	24.46	24.49	24.58	23.53	23.51	23.67
		1	24	24.52	24.57	23.76	23.56	23.57	23.04
		1	49	24.56	23.69	23.58	23.62	22.89	23.51
		25	0	23.22	23.21	23.35	22.21	22.22	22.26
		25	12	23.30	23.24	23.04	22.30	22.24	21.97
		25	24	23.26	23.27	22.56	22.30	22.28	22.06
		50	0	23.26	23.22	23.17	22.27	22.23	22.22
	256QAM	1	0	21.24	21.31	21.30	20.22	20.33	20.32
		1	24	21.32	21.45	21.13	20.44	20.48	20.04
		1	49	21.36	20.49	20.44	20.39	19.80	19.75
		25	0	21.17	21.22	21.34	20.19	20.23	20.21
		25	12	21.27	21.21	21.15	20.28	20.25	20.02
		25	24	21.23	21.27	20.57	20.23	20.29	19.98
		50	0	21.22	21.20	21.27	20.25	20.20	20.26

5G NR n12

Test Engineer ID:	12482	Test Date:	2024-03-01
--------------------------	-------	-------------------	------------

OUTPUT POWER FOR 5G NR n12 (5.0 MHz)

Bandwidth (MHz)	Modulation	RB Allocation	RB Offset	Conducted Average (dBm)					
				ANT 1			ANT 2		
				140300 701.5	141500 707.5	142700 713.5	140300 701.5	141500 707.5	142700 713.5
5.0	BPSK	1	0	25.70	25.61	25.54	25.13	25.07	25.06
		1	1	25.68	25.59	25.59	25.17	25.03	25.15
		1	23	25.63	25.55	25.56	25.03	25.15	24.98
		1	24	25.60	25.62	25.54	25.01	25.15	25.02
		12	6	25.65	25.65	25.56	25.09	25.17	25.08
		25	0	25.59	25.61	25.52	25.07	25.13	25.00
	QPSK	1	0	25.07	25.20	24.24	24.65	24.72	23.85
		1	1	25.64	25.59	25.13	25.12	25.12	24.84
		1	23	25.64	25.60	25.54	25.04	25.20	25.05
		1	24	25.12	24.90	24.85	24.66	24.12	24.69
		12	6	25.59	25.66	25.12	25.14	25.18	25.15
		25	0	24.92	25.24	24.25	24.69	24.54	24.18
	16QAM	1	0	24.10	24.47	23.41	23.69	23.79	22.67
		1	1	25.21	25.23	24.12	24.82	24.97	23.99
		1	23	25.28	24.72	24.96	24.60	23.82	24.81
		1	24	24.20	23.57	23.91	23.76	23.42	23.64
		12	6	25.00	25.26	24.20	24.63	24.69	24.09
		25	0	24.03	24.21	23.30	23.65	23.61	23.18
	64QAM	1	0	23.56	23.59	22.92	23.29	23.48	22.47
		1	1	23.55	23.49	22.75	23.49	23.21	22.76
		1	23	23.63	23.55	23.21	23.29	22.93	23.31
		1	24	23.38	23.47	23.06	23.51	22.86	23.68
		12	6	23.64	23.65	22.66	23.13	23.30	22.55
		25	0	23.57	23.71	22.84	23.21	23.14	22.76
	256QAM	1	0	21.46	21.26	21.21	21.12	21.18	20.89
		1	1	21.40	21.45	21.45	21.31	21.14	20.98
		1	23	21.53	21.57	21.44	21.34	20.99	21.03
		1	24	21.41	21.65	21.24	21.09	21.20	21.30
12		6	21.70	21.67	21.13	21.22	21.22	21.13	
25		0	21.75	21.74	21.30	21.12	21.16	21.16	

OUTPUT POWER FOR 5G NR n12 (10.0 MHz)

Bandwidth (MHz)	Modulation	RB Allocation	RB Offset	Conducted Average (dBm)					
				ANT 1			ANT 2		
				140800 704.0	141500 707.5	142200 711.0	140800 704.0	141500 707.5	142200 711.0
10.0	BPSK	1	0	25.68	25.64	25.63	25.06	25.03	25.07
		1	1	25.69	25.66	25.61	25.14	25.09	25.05
		1	50	25.60	25.64	25.46	24.98	24.96	24.99
		1	51	25.53	25.55	25.42	25.00	25.02	25.01
		25	12	25.49	25.64	25.47	25.00	24.98	25.02
		50	0	25.59	25.65	25.52	25.04	25.04	25.09
	QPSK	1	0	25.16	24.87	25.24	24.68	24.64	24.68
		1	1	25.68	25.65	25.61	25.13	25.05	25.20
		1	50	25.70	25.17	25.48	25.04	24.77	25.10
		1	51	25.14	24.13	24.82	24.44	23.80	24.57
		25	12	25.52	25.62	25.28	25.00	24.97	24.76
		50	0	25.20	25.17	24.70	24.69	24.42	24.04
	16QAM	1	0	24.25	23.87	24.28	23.98	23.69	23.65
		1	1	24.98	24.74	25.38	24.65	24.62	24.76
		1	50	25.29	23.98	24.76	24.54	23.91	24.78
		1	51	24.32	23.33	23.50	23.44	22.61	23.82
		25	12	25.16	25.25	24.46	24.54	24.63	23.78
		50	0	24.17	24.21	23.71	23.71	23.50	23.07
	64QAM	1	0	23.63	23.12	23.82	23.53	23.21	23.38
		1	1	23.52	23.10	23.61	23.39	23.43	23.34
		1	50	23.66	22.65	23.08	23.50	22.54	23.07
		1	51	23.31	22.52	23.13	23.05	22.64	23.53
		25	12	23.67	23.64	23.04	23.11	23.24	22.41
		50	0	23.73	23.63	23.24	23.17	23.03	22.66
	256QAM	1	0	21.46	21.41	21.46	21.21	20.96	21.05
		1	1	21.61	21.42	21.61	21.08	21.04	21.16
		1	50	21.69	20.96	21.13	21.09	20.84	21.27
		1	51	21.30	20.82	21.29	20.95	20.72	21.28
		25	12	21.67	21.65	21.63	21.11	21.11	20.87
		50	0	21.59	21.64	21.56	21.17	21.11	21.18

OUTPUT POWER FOR 5G NR n12 (15.0 MHz)

Bandwidth (MHz)	Modulation	RB Allocation	RB Offset	Conducted Average (dBm)						
				ANT 1			ANT 2			
				141300	141500	141700	141300	141500	141700	
15.0	BPSK	1	0	25.62	25.48	25.60	25.20	25.15	25.11	
		1	1	25.58	25.63	25.58	25.15	25.19	25.17	
		1	77	25.60	25.61	25.53	25.17	25.18	25.10	
		1	78	25.61	25.58	25.62	25.10	25.13	25.13	
		36	18	25.50	25.49	25.45	25.08	25.10	25.02	
		75	0	25.58	25.60	25.57	25.12	25.13	25.08	
		1	0	24.90	24.72	24.74	24.77	24.76	24.79	
		1	1	25.70	25.65	25.51	25.20	25.18	25.10	
		1	77	25.11	25.32	25.53	25.00	25.17	25.09	
	QPSK	1	78	24.19	24.30	24.74	24.18	24.46	24.62	
		36	18	25.60	25.56	25.62	25.16	25.09	25.12	
		75	0	25.05	24.89	24.79	24.35	24.21	24.14	
		1	0	23.77	23.84	23.75	23.52	23.86	23.83	
		1	1	24.81	24.80	24.84	24.85	24.59	24.11	
		1	77	24.16	24.55	24.41	23.91	24.60	24.66	
		1	78	23.24	23.55	23.75	23.03	23.35	23.73	
		36	18	25.25	25.20	25.19	24.63	24.54	24.24	
		75	0	23.87	23.86	23.89	23.38	23.33	23.14	
	16QAM	1	0	23.41	23.29	23.50	23.54	23.49	23.40	
		1	1	23.33	23.17	23.33	23.45	23.46	23.34	
		1	77	22.75	22.90	23.10	22.87	23.13	23.15	
		1	78	22.78	22.78	23.27	22.85	22.99	23.44	
		36	18	23.69	23.69	23.75	23.24	23.19	22.90	
		75	0	23.51	23.40	23.43	22.90	22.80	22.76	
		1	0	21.77	21.47	21.57	21.32	21.35	21.28	
		1	1	21.61	21.45	21.65	21.26	21.33	21.21	
		1	77	20.83	20.93	21.31	20.94	21.28	21.41	
	64QAM	1	78	20.90	21.16	21.29	20.89	21.20	20.99	
		36	18	21.65	21.65	21.66	21.24	21.17	21.15	
		75	0	21.65	21.64	21.77	21.25	21.20	21.18	
		256QAM	1	0	21.65	21.64	21.77	21.25	21.20	21.18

8.3. LTE BAND 13

Test Engineer ID:	12482	Test Date:	2024-02-17
-------------------	-------	------------	------------

OUTPUT POWER FOR LTE BAND 13 (5.0 MHz)

Bandwidth (MHz)	Modulation	RB Allocation	RB Offset	Conducted Average (dBm)					
				ANT 1			ANT 2		
				23205	23230	23255	23205	23230	23255
5.0	QPSK	1	0	779.5	782.0	784.5	779.5	782.0	784.5
		1	12	25.54	25.52	25.60	24.94	24.98	25.07
		1	24	25.62	25.70	25.69	25.07	25.20	25.18
		1	24	25.61	25.62	25.59	25.04	25.07	25.05
		12	0	25.09	25.16	25.19	24.03	24.11	24.13
		12	6	25.21	25.23	25.30	24.14	24.17	24.21
		12	11	25.19	25.28	25.28	24.13	24.19	24.17
	25	0	25.20	25.21	25.26	24.13	24.12	24.19	
	16QAM	1	0	25.29	25.23	25.35	24.15	24.20	24.31
		1	12	25.33	25.47	25.46	24.28	24.49	24.39
		1	24	25.33	25.33	25.36	24.15	24.28	24.29
		12	0	24.16	24.18	24.15	23.08	23.20	23.16
		12	6	24.27	24.27	24.39	23.21	23.25	23.27
		12	11	24.28	24.38	24.25	23.18	23.30	23.22
		25	0	24.19	24.18	24.26	23.14	23.14	23.19
	64QAM	1	0	24.53	24.52	24.68	23.37	23.44	23.39
		1	12	24.61	24.69	24.68	23.54	23.64	23.49
		1	24	24.64	24.63	24.64	23.52	23.44	23.54
		12	0	23.03	23.18	23.14	22.13	22.22	22.16
		12	6	23.29	23.23	23.35	22.24	22.29	22.29
		12	11	23.19	23.26	23.38	22.24	22.30	22.24
		25	0	23.19	23.19	23.29	22.13	22.15	22.21
	256QAM	1	0	21.14	21.14	21.25	20.16	20.19	20.16
		1	12	21.37	21.51	21.42	20.35	20.43	20.45
		1	24	21.44	21.34	21.36	20.37	20.26	20.35
		12	0	21.11	21.18	21.18	20.03	20.12	20.14
		12	6	21.25	21.22	21.32	20.18	20.19	20.26
		12	11	21.22	21.25	21.27	20.14	20.21	20.21
		25	0	21.16	21.17	21.22	20.14	20.15	20.20

OUTPUT POWER FOR LTE BAND 13 (10.0 MHz)

Bandwidth (MHz)	Modulation	RB Allocation	RB Offset	Conducted Average (dBm)					
				ANT 1			ANT 2		
				N/A	23230	N/A	N/A	23230	N/A
10.0	QPSK	1	0		25.53			25.07	
		1	24		25.70			25.20	
		1	49		25.66			25.16	
		25	0		25.19			24.22	
		25	12		25.28			24.29	
		25	24		25.33			24.32	
		50	0		25.26			24.27	
	16QAM	1	0		25.32			24.39	
		1	24		25.50			24.47	
		1	49		25.45			24.44	
		25	0		24.20			23.21	
		25	12		24.28			23.30	
		25	24		24.34			23.32	
		50	0		24.27			23.30	
	64QAM	1	0		24.31			23.48	
		1	24		24.55			23.60	
		1	49		24.55			23.59	
		25	0		23.23			22.24	
		25	12		23.28			22.31	
		25	24		23.32			22.36	
		50	0		23.27			22.31	
	256QAM	1	0		21.11			20.19	
		1	24		21.46			20.44	
		1	49		21.42			20.39	
		25	0		21.16			20.21	
		25	12		21.28			20.29	
		25	24		21.32			20.34	
		50	0		21.29			20.27	

8.4. LTE BAND 14 AND 5G NR n14

Test Engineer ID:	12482	Test Date:	2024-02-21
-------------------	-------	------------	------------

OUTPUT POWER FOR LTE BAND 14 (5.0 MHz)

Bandwidth (MHz)	Modulation	RB Allocation	RB Offset	Conducted Average (dBm)					
				ANT 1			ANT 2		
				23305	23330	23355	23305	23330	23355
5.0	QPSK	1	0	25.54	25.61	25.61	25.06	25.01	25.01
		1	12	25.60	25.70	25.68	25.20	25.17	25.16
		1	24	25.55	25.55	25.58	25.06	25.01	25.00
		12	0	24.62	24.68	24.65	24.11	24.11	24.09
		12	6	24.73	24.70	24.71	24.21	24.14	24.12
		12	11	24.71	24.73	24.76	24.15	24.16	24.16
		25	0	24.70	24.66	24.73	24.16	24.09	24.09
	16QAM	1	0	24.80	24.86	24.89	24.32	24.35	24.33
		1	12	24.94	24.95	24.91	24.41	24.46	24.43
		1	24	24.82	24.82	24.86	24.32	24.33	24.33
		12	0	23.64	23.67	23.70	23.14	23.07	23.10
		12	6	23.79	23.77	23.67	23.25	23.12	23.12
		12	11	23.85	23.73	23.71	23.19	23.16	23.14
		25	0	23.70	23.67	23.74	23.18	23.09	23.08
	64QAM	1	0	24.00	24.04	24.08	23.40	23.46	23.43
		1	12	24.14	24.13	24.11	23.50	23.54	23.44
		1	24	24.07	24.01	24.05	23.45	23.43	23.42
		12	0	22.69	22.64	22.76	22.18	22.17	22.16
		12	6	22.84	22.67	22.75	22.27	22.17	22.18
		12	11	22.75	22.75	22.80	22.26	22.23	22.23
		25	0	22.74	22.68	22.77	22.20	22.08	22.09
	256QAM	1	0	20.65	20.74	20.69	20.26	20.24	20.21
		1	12	20.87	20.80	20.87	20.38	20.36	20.39
		1	24	20.79	20.82	20.82	20.26	20.32	20.27
		12	0	20.64	20.68	20.71	20.09	20.09	20.10
		12	6	20.75	20.67	20.67	20.21	20.11	20.12
		12	11	20.71	20.73	20.74	20.18	20.17	20.14
		25	0	20.70	20.64	20.71	20.16	20.10	20.10

OUTPUT POWER FOR LTE BAND 14 (10.0 MHz)

Bandwidth (MHz)	Modulation	RB Allocation	RB Offset	Conducted Average (dBm)					
				ANT 1			ANT 2		
				N/A	23330	N/A	N/A	23330	N/A
10.0	QPSK	1	0		25.70			25.12	
		1	24		25.70			25.20	
		1	49		25.67			25.09	
		25	0		24.77			24.23	
		25	12		24.78			24.24	
		25	24		24.82			24.28	
		50	0		24.74			24.22	
	16QAM	1	0		24.97			24.36	
		1	24		24.98			24.46	
		1	49		24.93			24.39	
		25	0		23.79			23.24	
		25	12		23.79			23.25	
		25	24		23.83			23.28	
		50	0		23.74			23.24	
	64QAM	1	0		23.97			23.60	
		1	24		24.05			23.63	
		1	49		23.97			23.57	
		25	0		22.73			22.26	
		25	12		22.78			22.29	
		25	24		22.81			22.28	
		50	0		22.75			22.24	
	256QAM	1	0		20.82			20.19	
		1	24		20.97			20.34	
		1	49		20.85			20.29	
		25	0		20.74			20.24	
		25	12		20.76			20.23	
		25	24		20.81			20.30	
		50	0		20.74			20.21	

5G NR n14

Test Engineer ID:	12482	Test Date:	2024-02-21
-------------------	-------	------------	------------

OUTPUT POWER FOR 5G NR n14 (5.0 MHz)

Bandwidth (MHz)	Modulation	RB Allocation	RB Offset	Conducted Average (dBm)					
				ANT 1			ANT 2		
				158100	158600	159100	158100	158600	159100
5.0	BPSK	1	0	23.59	23.70	23.70	23.20	23.20	23.20
		1	1	25.58	25.33	25.49	25.11	25.15	25.20
		1	23	25.59	25.35	25.48	25.08	25.01	25.07
		1	24	23.70	23.65	23.47	23.19	23.11	23.02
		12	6	25.70	25.30	25.45	25.10	25.05	25.12
		25	0	25.50	25.44	25.37	25.07	25.01	25.10
	QPSK	1	0	23.57	23.70	23.70	23.20	23.19	23.20
		1	1	25.68	25.49	25.50	25.20	25.12	25.18
		1	23	25.62	25.50	25.54	25.05	25.05	25.06
		1	24	23.70	23.69	23.60	23.11	23.20	23.01
		12	6	25.64	25.49	25.54	25.10	25.18	25.14
		25	0	25.17	25.04	25.12	24.81	24.82	24.74
	16QAM	1	0	23.70	23.56	23.50	22.81	23.20	23.08
		1	1	24.98	25.06	25.12	24.63	24.76	24.75
		1	23	25.06	24.94	25.01	24.86	24.54	24.39
		1	24	23.34	23.36	23.70	22.72	23.20	22.76
		12	6	24.88	25.11	25.11	24.59	24.80	24.73
		25	0	23.96	24.03	24.03	23.72	23.81	23.74
	64QAM	1	0	23.13	22.99	23.12	22.59	22.88	22.82
		1	1	22.90	23.22	23.58	22.52	22.79	22.94
		1	23	23.00	23.40	23.24	22.87	22.91	22.68
		1	24	22.86	23.04	23.30	22.77	22.93	22.63
		12	6	23.37	23.51	23.61	23.08	23.32	23.24
		25	0	23.36	23.50	23.58	23.11	23.26	23.20
	256QAM	1	0	21.32	21.38	21.58	21.08	21.15	20.93
		1	1	21.28	21.38	21.58	21.03	21.01	20.95
		1	23	21.43	21.38	21.45	20.79	21.24	21.06
		1	24	21.31	21.58	21.64	21.09	21.02	20.86
		12	6	21.54	21.68	21.66	21.29	21.39	21.29
		25	0	21.45	21.54	21.59	21.19	21.27	21.24

OUTPUT POWER FOR 5G NR n14 (10.0 MHz)

Bandwidth (MHz)	Modulation	RB Allocation	RB Offset	Conducted Average (dBm)					
				ANT 1			ANT 2		
				N/A	158600	N/A	N/A	158600	N/A
10.0	BPSK	1	0		23.70			23.20	
		1	1		25.70			25.12	
		1	50		25.63			25.03	
		1	51		23.70			23.20	
		25	12		25.57			25.06	
		50	0		25.61			25.06	
	QPSK	1	0		23.70			23.20	
		1	1		25.58			25.12	
		1	50		25.65			25.20	
		1	51		23.70			23.20	
		25	12		25.61			25.16	
		50	0		25.19			24.56	
	16QAM	1	0		23.70			23.20	
		1	1		25.20			24.83	
		1	50		25.61			25.04	
		1	51		23.70			23.20	
		25	12		25.24			24.88	
		50	0		24.21			23.79	
	64QAM	1	0		22.89			22.97	
		1	1		23.52			22.77	
		1	50		23.14			22.68	
		1	51		23.11			22.81	
		25	12		23.70			23.11	
		50	0		23.71			23.31	
	256QAM	1	0		21.42			21.31	
		1	1		21.77			21.20	
		1	50		21.84			21.13	
		1	51		21.64			21.13	
		25	12		21.76			21.12	
		50	0		21.71			21.08	

8.5. LTE BAND 17

Test Engineer ID:	32061	Test Date:	2024-02-24
-------------------	-------	------------	------------

OUTPUT POWER FOR LTE BAND 17 (5.0 MHz)

Bandwidth (MHz)	Modulation	RB Allocation	RB Offset	Conducted Average (dBm)					
				ANT 1			ANT 2		
				23755	23790	23825	23755	23790	23825
5.0	QPSK	1	0	25.54	25.57	25.25	25.05	25.13	24.85
		1	12	25.70	25.59	25.34	25.20	24.96	25.16
		1	24	25.57	24.98	25.63	25.10	24.50	25.16
		12	0	25.12	25.18	23.98	24.13	24.24	23.71
		12	6	25.25	24.75	24.27	24.27	24.15	24.09
		12	11	25.22	24.28	24.82	24.23	23.83	24.32
		25	0	25.21	24.74	24.34	24.22	24.03	24.09
	16QAM	1	0	25.23	25.39	24.42	24.29	24.43	24.05
		1	12	25.32	24.80	24.47	24.39	24.15	24.33
		1	24	25.34	24.13	24.98	24.33	23.74	24.44
		12	0	24.14	24.13	23.11	23.11	23.14	22.87
		12	6	24.27	23.91	23.44	23.24	23.16	23.24
		12	11	24.21	23.45	23.93	23.20	22.89	23.37
		25	0	24.23	23.89	23.50	23.24	23.23	23.25
	64QAM	1	0	24.42	24.49	23.70	23.40	23.50	23.23
		1	12	24.54	24.09	23.69	23.55	23.37	23.42
		1	24	24.50	23.44	24.21	23.44	22.94	23.51
		12	0	23.13	23.08	22.23	22.26	22.37	21.88
		12	6	23.24	22.97	22.50	22.39	22.38	22.19
		12	11	23.21	22.49	22.97	22.36	22.09	22.37
		25	0	23.25	22.98	22.60	22.25	22.24	22.25
	256QAM	1	0	21.27	21.34	20.90	20.27	20.31	20.36
		1	12	21.42	21.30	20.70	20.38	20.49	20.39
		1	24	21.32	20.67	20.92	20.38	19.97	20.40
		12	0	21.13	21.17	20.27	20.16	20.25	19.88
		12	6	21.25	21.17	20.43	20.29	20.28	20.18
		12	11	21.21	20.64	20.87	20.26	20.07	20.30
		25	0	21.21	21.12	20.56	20.25	20.20	20.23

OUTPUT POWER FOR LTE BAND 17 (10.0 MHz)

Bandwidth (MHz)	Modulation	RB Allocation	RB Offset	Conducted Average (dBm)					
				ANT 1			ANT 2		
				23780	23790	23800	23780	23790	23800
10.0	QPSK	1	0	25.62	25.65	25.65	25.13	25.15	25.19
		1	24	25.68	25.70	25.32	25.20	25.05	24.83
		1	49	25.16	25.44	25.63	24.72	25.15	25.13
		25	0	25.23	25.24	25.25	24.26	24.24	24.28
		25	12	25.23	24.82	24.48	24.35	24.15	23.96
		25	24	24.39	24.23	24.37	23.94	23.87	24.10
		50	0	24.98	24.80	24.66	24.26	24.17	24.09
	16QAM	1	0	25.41	25.46	25.40	24.43	24.43	24.47
		1	24	25.28	24.84	24.37	24.47	24.21	23.89
		1	49	24.26	24.44	24.61	23.90	24.34	24.30
		25	0	24.22	24.25	24.25	23.27	23.31	23.31
		25	12	24.32	24.02	23.61	23.36	23.30	23.10
		25	24	23.55	23.38	23.47	23.06	23.05	23.17
		50	0	24.18	24.00	23.91	23.25	23.27	23.26
	64QAM	1	0	24.53	24.51	24.54	23.51	23.59	23.63
		1	24	24.57	24.18	23.79	23.57	23.58	23.30
		1	49	23.61	23.71	24.06	23.20	23.54	23.55
		25	0	23.25	23.24	23.25	22.27	22.30	22.29
		25	12	23.37	23.16	22.79	22.36	22.34	22.15
		25	24	22.66	22.42	22.57	22.12	22.04	22.18
		50	0	23.21	23.10	22.97	22.28	22.28	22.29
	256QAM	1	0	21.24	21.30	21.28	20.32	20.29	20.36
		1	24	21.43	21.38	20.99	20.44	20.50	20.31
		1	49	20.41	20.57	20.50	19.86	20.07	20.08
		25	0	21.20	21.22	21.24	20.24	20.29	20.29
		25	12	21.31	21.23	20.96	20.35	20.31	20.18
		25	24	20.77	20.49	20.61	20.14	20.06	20.19
		50	0	21.23	21.19	21.16	20.27	20.25	20.28

8.6. LTE BAND 25 AND 5G NR n25

LTE BAND 25

Test Engineer ID:	32061	Test Date:	2024-02-24
-------------------	-------	------------	------------

OUTPUT POWER FOR LTE BAND 25 (1.4 MHz)

Bandwidth (MHz)	Modulation	RB Allocation	RB Offset	Conducted Average (dBm)												
				ANT 1			ANT 2			ANT 3			ANT 4			
				26047	26365	26683	26047	26365	26683	26047	26365	26683	26047	26365	26683	
1.4	QPSK	1	0	25.61	25.51	25.64	23.36	23.34	23.26	25.43	25.33	25.45	22.85	22.53	22.64	
		1	2	25.65	25.53	25.65	23.40	23.37	23.33	25.47	25.37	25.50	22.90	22.56	22.66	
		1	5	25.63	25.55	25.70	23.36	23.36	23.28	25.44	25.35	25.49	22.84	22.52	22.68	
		3	0	25.62	25.53	25.67	23.35	23.37	23.26	25.43	25.33	25.50	22.82	22.51	22.62	
		3	1	25.60	25.52	25.69	23.33	23.40	23.28	25.47	25.35	25.49	22.79	22.51	22.64	
		3	2	25.64	25.47	25.70	23.35	23.36	23.27	25.44	25.37	25.49	22.82	22.50	22.61	
	16QAM	6	0	25.21	25.08	25.20	22.34	22.33	22.25	24.83	24.81	24.86	21.81	21.47	21.56	
		1	0	25.38	25.26	25.40	22.42	22.43	22.40	24.96	24.96	25.07	22.04	21.60	21.80	
		1	2	25.47	25.29	25.41	22.55	22.48	22.49	25.00	25.00	25.03	22.02	21.72	21.84	
		1	5	25.34	25.31	25.44	22.57	22.46	22.46	25.01	24.94	25.06	21.97	21.70	21.74	
		3	0	25.31	25.15	25.35	22.42	22.39	22.40	24.91	24.92	24.91	21.99	21.57	21.77	
		3	1	25.33	25.11	25.40	22.45	22.44	22.41	24.91	24.93	24.89	21.94	21.59	21.73	
	64QAM	3	2	25.31	25.16	25.40	22.42	22.46	22.44	24.91	24.93	24.89	21.96	21.54	21.78	
		6	0	24.20	24.07	24.28	21.34	21.42	21.24	23.83	23.87	23.87	20.82	20.51	20.63	
		1	0	24.36	24.46	24.61	21.59	21.49	21.55	24.00	24.00	23.97	21.07	20.72	20.97	
		1	2	24.48	24.45	24.57	21.61	21.69	21.63	24.08	24.06	24.09	21.09	20.79	20.94	
		1	5	24.38	24.45	24.58	21.67	21.65	21.53	24.02	23.98	24.03	20.99	20.62	20.97	
		3	0	24.38	24.24	24.40	21.49	21.51	21.39	23.89	23.93	23.97	20.94	20.75	20.75	
	256QAM	3	1	24.44	24.22	24.44	21.47	21.48	21.42	23.91	23.95	23.97	21.00	20.74	20.78	
		3	2	24.42	24.27	24.42	21.46	21.49	21.38	23.93	23.94	23.98	20.96	20.75	20.78	
		6	0	23.29	23.14	23.26	20.39	20.38	20.33	22.78	22.86	22.81	19.87	19.67	19.62	
		1	0	21.25	21.15	21.34	18.42	18.41	18.50	20.94	20.88	20.88	17.84	17.73	17.70	
		1	2	21.30	21.23	21.45	18.49	18.46	18.47	20.95	20.92	20.94	17.92	17.67	17.76	
		1	5	21.26	21.24	21.36	18.46	18.40	18.46	20.89	20.88	20.94	17.89	17.63	17.77	
	1.4	256QAM	3	0	21.28	21.13	21.30	18.37	18.37	18.27	21.00	20.91	21.04	17.92	17.59	17.58
			3	1	21.25	21.16	21.38	18.38	18.40	18.29	21.05	20.91	21.06	17.91	17.59	17.63
			3	2	21.26	21.14	21.41	18.37	18.38	18.28	21.06	20.90	21.03	17.93	17.59	17.63
			6	0	21.20	21.06	21.13	18.38	18.38	18.32	20.77	20.81	20.79	17.81	17.60	17.57

OUTPUT POWER FOR LTE BAND 25 (3.0 MHz)

Bandwidth (MHz)	Modulation	RB Allocation	RB Offset	Conducted Average (dBm)												
				ANT 1			ANT 2			ANT 3			ANT 4			
				26055	26365	26675	26055	26365	26675	26055	26365	26675	26055	26365	26675	
3.0	QPSK	1	0	25.51	25.41	25.57	23.27	23.23	23.18	25.29	24.76	25.36	22.82	22.47	22.57	
		1	7	25.63	25.51	25.70	23.35	23.40	23.28	25.39	24.62	25.50	22.90	22.57	22.75	
		1	14	25.54	25.43	25.65	23.25	23.31	23.17	25.33	24.47	25.34	22.77	22.50	22.64	
		8	0	25.21	25.09	25.22	22.33	22.30	22.17	24.83	23.91	24.86	21.86	21.46	21.60	
		8	4	25.24	25.14	25.32	22.39	22.31	22.20	24.86	23.86	24.89	21.88	21.50	21.65	
		8	7	25.25	25.14	25.33	22.36	22.39	22.28	24.86	23.89	24.90	21.86	21.56	21.72	
	16QAM	15	0	25.13	25.08	25.32	22.31	22.27	22.17	24.81	23.73	24.84	21.86	21.53	21.61	
		1	0	25.26	25.28	25.43	22.38	22.34	22.34	24.94	23.81	24.87	21.95	21.53	21.84	
		1	7	25.39	25.29	25.53	22.57	22.51	22.42	25.00	23.78	25.01	22.07	21.70	21.96	
		1	14	25.38	25.28	25.33	22.37	22.43	22.35	24.90	23.76	24.90	21.97	21.66	21.88	
		8	0	24.22	24.11	24.16	21.35	21.32	21.21	23.83	22.91	23.86	20.88	20.51	20.63	
		8	4	24.31	24.13	24.31	21.38	21.37	21.26	23.89	22.92	23.89	20.91	20.52	20.67	
	64QAM	8	7	24.26	24.13	24.33	21.38	21.45	21.32	23.86	22.94	23.91	20.91	20.61	20.75	
		15	0	24.14	24.09	24.31	21.31	21.28	21.19	23.82	22.84	23.86	20.83	20.56	20.62	
		1	0	24.56	24.35	24.55	21.41	21.58	21.52	23.93	23.12	23.87	21.18	20.81	20.97	
		1	7	24.54	24.47	24.60	21.52	21.59	21.62	24.01	23.01	24.00	21.11	20.82	21.10	
		1	14	24.57	24.45	24.57	21.40	21.54	21.55	23.89	22.99	23.92	21.10	20.96	20.98	
		8	0	23.26	23.13	23.28	20.36	20.32	20.26	22.84	21.98	22.86	19.93	19.51	19.64	
	256QAM	8	4	23.32	23.16	23.40	20.42	20.37	20.33	22.85	22.01	22.87	19.99	19.54	19.68	
		8	7	23.30	23.14	23.39	20.39	20.47	20.41	22.86	22.02	22.86	19.96	19.62	19.76	
		15	0	23.12	23.16	23.33	20.36	20.30	20.21	22.85	21.93	22.88	19.89	19.59	19.65	
		1	0	21.23	21.16	21.26	18.31	18.44	18.33	20.87	20.12	20.86	17.85	17.55	17.70	
		1	7	21.42	21.28	21.43	18.47	18.60	18.42	20.97	20.09	20.93	17.94	17.79	17.89	
		1	14	21.18	21.19	21.32	18.40	18.47	18.32	20.77	20.05	20.82	17.89	17.70	17.75	
	3.0	256QAM	8	0	21.21	21.13	21.23	18.35	18.30	18.23	20.83	20.08	20.81	17.87	17.51	17.63
			8	4	21.27	21.15	21.35	18.41	18.34	18.24	20.87	20.07	20.84	17.94	17.52	17.66
			8	7	21.26	21.15	21.33	18.40	18.39	18.33	20.83	20.10	20.83	17.92	17.62	17.74
			15	0	21.11	21.10	21.28	18.32	18.30	18.21	20.82	20.02	20.82	17.85	17.56	17.64

OUTPUT POWER FOR LTE BAND 25 (5.0 MHz)

Bandwidth (MHz)	Modulation	RB Allocation	RB Offset	Conducted Average (dBm)											
				ANT 1			ANT 2			ANT 3			ANT 4		
				26065	26365	26665	26065	26365	26665	26065	26365	26665	26065	26365	26665
5.0	QPSK	1	0	25.50	25.32	25.52	23.27	23.28	23.29	25.37	25.34	25.37	22.83	22.45	22.64
		1	12	25.56	25.47	25.70	23.37	23.40	23.32	25.50	25.47	25.48	22.90	22.60	22.76
		1	24	25.42	25.38	25.56	23.26	23.31	23.23	25.35	25.38	25.41	22.77	22.48	22.65
		12	0	25.09	24.93	25.13	22.33	22.27	22.28	24.80	24.78	24.83	21.86	21.46	21.60
		12	6	25.09	25.05	25.16	22.38	22.29	22.29	24.86	24.82	24.84	21.84	21.50	21.70
		12	11	25.04	25.03	25.21	22.35	22.34	22.28	24.81	24.76	24.83	21.83	21.54	21.67
		25	0	25.04	25.02	25.12	22.33	22.27	22.26	24.81	24.78	24.84	21.83	21.54	21.66
	16QAM	1	0	25.30	25.09	25.37	22.52	22.44	22.31	24.85	24.94	24.87	22.02	21.66	21.86
		1	12	25.44	25.27	25.48	22.62	22.55	22.43	25.00	25.00	25.03	22.19	21.85	21.94
		1	24	25.27	25.21	25.39	22.51	22.49	22.31	24.84	24.88	24.92	22.00	21.70	21.87
		12	0	24.14	23.94	24.12	21.43	21.38	21.27	23.69	23.87	23.87	20.93	20.41	20.51
		12	6	24.08	24.07	24.18	21.48	21.44	21.29	23.71	23.87	23.88	20.93	20.45	20.61
		12	11	24.08	24.01	24.23	21.42	21.48	21.26	23.71	23.85	23.84	20.89	20.49	20.59
		25	0	24.04	24.02	24.11	21.35	21.30	21.27	23.81	23.79	23.84	20.83	20.58	20.69
	64QAM	1	0	24.36	24.23	24.43	21.52	21.59	21.55	23.97	23.99	23.93	21.09	20.82	20.87
		1	12	24.45	24.36	24.45	21.63	21.72	21.62	23.92	24.07	24.08	21.12	20.85	20.95
		1	24	24.40	24.27	24.46	21.59	21.63	21.55	23.96	23.94	24.00	21.00	20.82	20.89
		12	0	23.19	22.98	23.17	20.42	20.38	20.35	22.86	22.81	22.85	19.92	19.56	19.66
		12	6	23.12	23.10	23.22	20.44	20.42	20.41	22.85	22.84	22.89	19.94	19.58	19.77
		12	11	23.09	23.03	23.29	20.41	20.49	20.37	22.83	22.81	22.87	19.89	19.64	19.74
		25	0	23.05	23.02	23.13	20.35	20.25	20.29	22.81	22.81	22.83	19.89	19.56	19.71
	256QAM	1	0	21.25	21.07	21.20	18.35	18.37	18.39	20.86	20.87	20.90	17.99	17.61	17.69
		1	12	21.32	21.23	21.37	18.50	18.53	18.48	20.98	20.93	21.00	18.03	17.79	17.85
		1	24	21.17	21.16	21.30	18.44	18.47	18.40	20.86	20.71	20.90	17.95	17.74	17.80
		12	0	21.08	20.92	21.10	18.33	18.26	18.29	20.79	20.78	20.78	17.87	17.50	17.62
		12	6	21.05	21.04	21.13	18.35	18.32	18.32	20.81	20.81	20.85	17.87	17.52	17.72
		12	11	21.03	21.00	21.20	18.33	18.35	18.28	20.76	20.80	20.79	17.85	17.53	17.67
		25	0	21.02	21.00	21.11	18.33	18.28	18.26	20.75	20.78	20.82	17.85	17.57	17.71

OUTPUT POWER FOR LTE BAND 25 (10.0 MHz)

Bandwidth (MHz)	Modulation	RB Allocation	RB Offset	Conducted Average (dBm)											
				ANT 1			ANT 2			ANT 3			ANT 4		
				26090	26365	26640	26090	26365	26640	26090	26365	26640	26090	26365	26640
10.0	QPSK	1	0	25.59	25.48	25.63	23.29	23.34	23.31	25.29	25.08	25.43	22.90	22.57	22.64
		1	24	25.62	25.57	25.69	23.33	23.39	23.31	25.32	25.18	25.48	22.88	22.59	22.69
		1	49	25.57	25.55	25.70	23.29	23.40	23.27	25.24	25.18	25.50	22.80	22.53	22.70
		25	0	25.25	25.10	25.18	22.27	22.33	22.24	24.75	24.46	24.81	21.86	21.52	21.61
		25	12	25.28	25.21	25.35	22.37	22.34	22.26	24.68	24.51	24.84	21.88	21.54	21.72
		25	24	25.16	25.17	25.32	22.33	22.40	22.32	24.65	24.59	24.91	21.77	21.59	21.70
		50	0	25.25	25.15	25.33	22.34	22.32	22.26	24.66	24.57	24.81	21.78	21.61	21.71
	16QAM	1	0	25.33	25.18	25.45	22.48	22.40	22.45	24.85	24.69	25.06	22.04	21.77	21.88
		1	24	25.37	25.23	25.46	22.51	22.54	22.42	24.84	24.74	25.05	22.03	21.79	21.88
		1	49	25.38	25.25	25.45	22.48	22.52	22.38	24.79	24.76	25.06	21.97	21.73	21.85
		25	0	24.24	24.06	24.20	21.27	21.33	21.27	23.76	23.48	23.81	20.91	20.52	20.62
		25	12	24.27	24.16	24.35	21.38	21.36	21.25	23.70	23.52	23.84	20.92	20.56	20.74
		25	24	24.16	24.20	24.34	21.37	21.43	21.31	23.67	23.60	23.92	20.79	20.62	20.72
		50	0	24.25	24.16	24.31	21.37	21.33	21.24	23.63	23.55	23.80	20.80	20.60	20.72
	64QAM	1	0	24.42	24.37	24.52	21.63	21.59	21.46	23.85	23.70	23.89	21.16	20.81	20.96
		1	24	24.51	24.43	24.55	21.59	21.63	21.46	23.96	23.70	24.00	21.14	20.84	21.01
		1	49	24.51	24.47	24.59	21.60	21.65	21.44	23.84	23.77	24.03	21.11	20.67	21.00
		25	0	23.25	23.04	23.21	20.29	20.30	20.24	22.74	22.53	22.77	19.89	19.58	19.65
		25	12	23.30	23.16	23.34	20.39	20.36	20.27	22.65	22.57	22.82	19.92	19.62	19.74
		25	24	23.14	23.12	23.32	20.39	20.39	20.32	22.62	22.63	22.86	19.79	19.66	19.73
		50	0	23.22	23.14	23.30	20.34	20.30	20.26	22.64	22.61	22.78	19.78	19.64	19.74
	256QAM	1	0	21.21	21.08	21.26	18.36	18.32	18.31	20.77	20.45	20.85	18.02	17.71	17.74
		1	24	21.28	21.25	21.40	18.56	18.45	18.49	20.82	20.63	21.03	18.01	17.81	17.89
		1	49	21.15	21.18	21.36	18.47	18.40	18.44	20.59	20.68	20.85	17.87	17.78	17.82
		25	0	21.20	21.02	21.19	18.26	18.31	18.24	20.71	20.48	20.70	17.89	17.56	17.62
		25	12	21.24	21.14	21.30	18.37	18.35	18.27	20.65	20.51	20.72	17.88	17.58	17.74
		25	24	21.15	21.11	21.29	18.37	18.40	18.33	20.60	20.59	20.78	17.79	17.62	17.71
		50	0	21.23	21.09	21.26	18.35	18.30	18.25	20.62	20.58	20.73	17.80	17.64	17.72

OUTPUT POWER FOR LTE BAND 25 (15.0 MHz)

Bandwidth (MHz)	Modulation	RB Allocation	RB Offset	Conducted Average (dBm)											
				ANT 1			ANT 2			ANT 3			ANT 4		
				26115 1857.5	26365 1882.5	26615 1907.5	26115 1857.5	26365 1882.5	26615 1907.5	26115 1857.5	26365 1882.5	26615 1907.5	26115 1857.5	26365 1882.5	26615 1907.5
15.0	QPSK	1	0	25.61	25.56	25.63	23.34	23.38	23.26	25.26	25.15	25.36	22.90	22.63	22.70
		1	37	25.56	25.57	25.69	23.36	23.36	23.29	25.24	25.22	25.47	22.83	22.61	22.77
		1	74	25.61	25.54	25.70	23.40	23.33	23.22	25.28	25.20	25.50	22.78	22.55	22.73
		36	0	25.28	25.16	25.28	22.32	22.33	22.27	24.75	24.55	24.85	21.93	21.62	21.72
		36	16	25.19	25.23	25.33	22.41	22.33	22.33	24.73	24.56	24.86	21.81	21.61	21.71
		36	35	25.18	25.25	25.42	22.42	22.42	22.32	24.64	24.64	24.95	21.80	21.68	21.80
		75	0	25.17	25.21	25.31	22.40	22.32	22.33	24.70	24.63	24.86	21.80	21.68	21.80
	16QAM	1	0	25.47	25.33	25.47	22.47	22.45	22.41	24.82	24.73	24.94	22.13	21.86	21.86
		1	37	25.52	25.41	25.60	22.50	22.49	22.44	24.81	24.77	25.02	22.11	21.88	21.99
		1	74	25.48	25.36	25.58	22.62	22.43	22.33	24.83	24.72	25.04	22.03	21.78	21.90
		36	0	24.27	24.17	24.29	21.34	21.36	21.30	23.75	23.56	23.85	20.94	20.64	20.69
		36	16	24.21	24.24	24.34	21.42	21.35	21.35	23.74	23.57	23.85	20.85	20.64	20.72
		36	35	24.19	24.25	24.43	21.42	21.42	21.34	23.63	23.67	23.96	20.80	20.71	20.82
		75	0	24.19	24.23	24.32	21.44	21.34	21.36	23.73	23.62	23.88	20.83	20.70	20.81
	64QAM	1	0	24.47	24.41	24.52	21.65	21.64	21.58	23.85	23.66	23.97	21.17	20.89	20.98
		1	37	24.49	24.35	24.57	21.70	21.69	21.62	23.85	23.68	24.04	21.16	20.88	20.98
		1	74	24.62	24.50	24.63	21.81	21.65	21.56	23.86	23.68	24.07	21.15	20.83	21.05
		36	0	23.28	23.16	23.32	20.34	20.34	20.26	22.77	22.56	22.87	19.94	19.67	19.73
		36	16	23.20	23.23	23.31	20.42	20.33	20.34	22.74	22.58	22.85	19.84	19.64	19.73
		36	35	23.19	23.24	23.41	20.42	20.41	20.34	22.63	22.68	22.96	19.81	19.74	19.82
		75	0	23.19	23.22	23.30	20.43	20.33	20.33	22.74	22.64	22.87	19.82	19.73	19.80
	256QAM	1	0	21.37	21.29	21.32	18.30	18.34	18.37	20.80	20.74	20.86	18.09	17.75	17.77
		1	37	21.37	21.30	21.51	18.39	18.42	18.46	20.76	20.73	20.97	18.05	17.76	17.86
		1	74	21.29	21.42	21.57	18.43	18.47	18.44	20.70	20.79	21.04	18.00	17.88	17.94
36		0	21.25	21.11	21.22	18.32	18.34	18.27	20.71	20.54	20.83	17.95	17.70	17.73	
36		16	21.18	21.16	21.26	18.41	18.33	18.32	20.70	20.53	20.85	17.84	17.66	17.71	
36		35	21.17	21.20	21.39	18.40	18.40	18.31	20.62	20.63	20.92	17.81	17.74	17.81	
75		0	21.17	21.19	21.28	18.41	18.34	18.34	20.70	20.63	20.83	17.84	17.75	17.80	

OUTPUT POWER FOR LTE BAND 25 (20.0 MHz)

Bandwidth (MHz)	Modulation	RB Allocation	RB Offset	Conducted Average (dBm)											
				ANT 1			ANT 2			ANT 3			ANT 4		
				26140 1860.0	26365 1882.5	26590 1905.0	26140 1860.0	26365 1882.5	26590 1905.0	26140 1860.0	26365 1882.5	26590 1905.0	26140 1860.0	26365 1882.5	26590 1905.0
20.0	QPSK	1	0	25.62	25.53	25.56	23.33	23.40	23.31	25.25	25.15	25.35	22.90	22.67	22.72
		1	49	25.56	25.50	25.69	23.35	23.36	23.27	25.27	25.15	25.41	22.86	22.71	22.74
		1	99	25.54	25.56	25.70	23.32	23.31	23.28	25.18	25.17	25.50	22.80	22.66	22.80
		50	0	25.24	25.14	25.24	22.36	22.38	22.31	24.74	24.52	24.80	21.98	21.73	21.74
		50	24	25.28	25.24	25.35	22.44	22.39	22.38	24.63	24.64	24.91	21.97	21.79	21.88
		50	49	25.15	25.23	25.35	22.41	22.46	22.34	24.59	24.64	24.89	21.91	21.76	21.86
		100	0	25.24	25.23	25.34	22.41	22.38	22.39	24.63	24.62	24.91	21.94	21.77	21.88
	16QAM	1	0	25.34	25.30	25.31	22.49	22.52	22.47	24.67	24.59	24.87	22.09	21.90	21.95
		1	49	25.50	25.59	25.61	22.68	22.60	22.64	24.78	24.76	25.10	22.15	22.02	22.22
		1	99	25.28	25.31	25.47	22.50	22.43	22.43	24.61	24.63	25.08	22.02	21.84	21.98
		50	0	24.25	24.16	24.25	21.35	21.41	21.30	23.73	23.53	23.78	20.99	20.70	20.76
		50	24	24.26	24.25	24.34	21.44	21.41	21.39	23.64	23.64	23.90	20.97	20.79	20.87
		50	49	24.17	24.23	24.35	21.41	21.43	21.35	23.61	23.65	23.87	20.92	20.75	20.86
		100	0	24.25	24.22	24.34	21.42	21.39	21.39	23.62	23.62	23.89	20.94	20.79	20.88
	64QAM	1	0	24.33	24.34	24.48	21.52	21.75	21.66	23.86	23.70	24.90	21.22	20.98	20.96
		1	49	24.50	24.47	24.56	21.60	21.97	21.79	23.91	23.78	24.23	21.21	21.16	21.04
		1	99	24.35	24.40	24.56	21.51	21.69	21.67	23.78	23.71	24.21	21.05	20.88	21.05
		50	0	23.22	23.08	23.26	20.37	20.39	20.37	22.73	22.51	22.79	19.98	19.72	19.75
		50	24	23.24	23.23	23.38	20.44	20.40	20.42	22.64	22.61	22.89	19.95	19.78	19.87
		50	49	23.12	23.20	23.37	20.42	20.44	20.40	22.58	22.62	22.89	19.90	19.75	19.88
		100	0	23.22	23.21	23.36	20.43	20.38	20.42	22.61	22.61	22.90	19.97	19.79	19.86
	256QAM	1	0	21.40	21.27	21.29	18.46	18.48	18.46	20.81	20.69	20.92	18.16	17.88	17.92
		1	49	21.30	21.34	21.38	18.54	18.47	18.66	20.79	20.71	21.02	18.07	17.92	17.93
		1	99	21.26	21.33	21.49	18.58	18.50	18.48	20.71	20.80	21.10	18.12	17.93	18.07
50		0	21.20	21.08	21.21	18.33	18.38	18.33	20.68	20.48	20.75	17.98	17.72	17.74	
50		24	21.23	21.18	21.36	18.44	18.37	18.40	20.62	20.61	20.87	17.98	17.79	17.87	
50		49	21.15	21.20	21.36	18.42	18.46	18.40	20.59	20.59	20.87	17.94	17.77	17.86	
100		0	21.19	21.18	21.37	18.42	18.58	18.42	20.60	20.58	20.86	17.96	17.78	17.85	

5G NR n25

Test Engineer ID:	12482	Test Date:	2/24/2024
--------------------------	-------	-------------------	-----------

OUTPUT POWER FOR 5G NR n25 (5.0 MHz)

Bandwidth (MHz)	Modulation	RB Allocation	RB Offset	Conducted Average (dBm)											
				ANT 1			ANT 2			ANT 3			ANT 4		
				370500	376500	382500	370500	376500	382500	370500	376500	382500	370500	376500	382500
5.0	BPSK	1	0	25.61	25.49	25.40	23.17	23.22	23.22	25.09	25.27	25.33	22.57	22.80	22.58
		1	1	25.65	25.41	25.41	23.23	23.26	23.27	25.08	25.14	25.33	22.63	22.89	22.64
		1	23	25.62	25.43	25.45	23.18	23.22	23.18	25.16	25.18	25.50	22.58	22.90	22.60
		1	24	25.59	25.37	25.45	23.23	23.29	23.14	25.08	25.23	25.38	22.51	22.82	22.56
		12	6	25.64	25.41	25.46	23.22	23.22	23.22	25.10	25.17	25.39	22.54	22.79	22.62
		25	0	25.62	25.38	25.43	23.18	23.19	23.11	25.09	25.23	25.36	22.49	22.78	22.56
	QPSK	1	0	25.25	25.02	24.75	22.88	22.94	22.49	24.84	24.86	25.04	22.16	22.50	22.26
		1	1	25.70	25.44	25.50	23.40	23.31	23.31	25.24	25.33	25.46	22.66	22.89	22.62
		1	23	25.70	25.49	25.37	23.27	23.28	23.17	25.32	25.40	25.41	22.51	22.88	22.66
		1	24	25.26	25.10	24.43	22.91	22.82	22.17	24.82	24.91	24.55	22.24	22.45	22.18
		12	6	25.67	25.45	25.45	23.21	23.24	23.15	25.17	25.22	25.44	22.59	22.87	22.62
		25	0	25.05	24.88	24.79	22.63	22.75	22.81	24.59	24.36	24.86	22.19	22.38	22.23
	16QAM	1	0	24.09	23.95	23.85	21.90	21.90	21.68	23.90	23.99	23.99	21.54	21.55	20.98
		1	1	25.24	25.04	24.99	22.78	23.06	22.57	25.01	24.83	24.90	21.90	22.71	22.44
		1	23	25.01	25.17	24.58	22.61	22.80	22.37	24.65	24.93	24.77	22.46	22.22	22.33
		1	24	24.41	24.34	23.13	21.83	21.93	21.20	23.82	23.75	23.79	21.23	21.30	21.24
		12	6	25.25	25.01	25.07	22.86	22.88	22.80	24.73	24.75	25.02	22.25	22.38	22.18
		25	0	24.25	23.97	24.03	21.69	21.92	21.85	23.83	23.63	24.07	21.25	21.45	21.27
	64QAM	1	0	23.52	23.41	23.43	21.04	21.14	20.93	23.11	22.91	23.29	20.43	20.64	20.28
		1	1	23.81	23.35	23.44	21.22	21.36	20.95	23.09	22.80	23.35	20.27	20.76	20.47
		1	23	23.64	23.43	23.02	21.26	21.42	20.99	23.02	22.83	23.01	20.40	20.53	20.51
		1	24	23.87	23.61	23.01	21.51	21.34	20.79	23.00	23.17	23.23	20.68	20.37	20.45
		12	6	23.51	23.46	23.45	21.27	21.28	21.22	23.29	23.31	23.54	20.87	20.80	20.89
		25	0	23.66	23.49	23.48	21.36	21.32	21.34	23.31	23.18	23.51	20.71	20.89	20.83
	256QAM	1	0	21.74	21.65	21.44	19.39	19.52	19.42	21.17	21.26	21.47	18.74	18.85	18.81
1		1	21.76	21.52	21.64	19.41	19.45	19.32	21.27	21.13	21.62	18.90	19.08	18.72	
1		23	21.41	21.54	21.66	19.50	19.13	19.31	21.51	21.22	21.45	18.85	18.84	18.81	
1		24	21.78	21.54	21.32	19.25	19.40	19.22	21.07	21.31	21.59	18.63	18.82	18.96	
12		6	21.57	21.39	21.51	19.17	19.27	19.22	21.35	21.32	21.60	18.92	18.91	18.91	
25		0	21.70	21.42	21.50	19.33	19.33	19.29	21.26	21.26	21.55	18.89	18.83	18.82	

OUTPUT POWER FOR 5G NR n25 (10.0 MHz)

Bandwidth (MHz)	Modulation	RB Allocation	RB Offset	Conducted Average (dBm)											
				ANT 1			ANT 2			ANT 3			ANT 4		
				371000	376500	382000	371000	376500	382000	371000	376500	382000	371000	376500	382000
10.0	BPSK	1	0	25.63	25.42	25.46	23.20	23.32	23.26	25.22	25.17	25.16	22.73	22.86	22.81
		1	1	25.63	25.40	25.47	23.22	23.28	23.23	25.24	25.27	25.26	22.72	22.83	22.82
		1	50	25.60	25.42	25.50	23.18	23.29	23.23	25.20	25.28	25.36	22.66	22.89	22.76
		1	51	25.63	25.43	25.49	23.14	23.27	23.31	25.26	25.22	25.36	22.64	22.80	22.79
		25	12	25.61	25.44	25.49	23.15	23.25	23.24	25.28	25.25	25.37	22.68	22.84	22.75
		50	0	25.70	25.50	25.53	23.24	23.33	23.29	25.32	25.36	25.43	22.72	22.90	22.81
	QPSK	1	0	25.27	25.09	25.05	22.77	22.78	22.74	24.92	24.83	25.07	22.35	22.41	22.29
		1	1	25.69	25.44	25.53	23.23	23.33	23.19	25.26	25.41	25.50	22.78	22.82	22.79
		1	50	25.65	25.54	25.45	23.27	23.40	23.27	25.30	25.32	25.40	22.71	22.87	22.80
		1	51	25.22	25.05	24.45	22.80	22.90	22.25	24.82	24.91	24.61	22.23	22.40	22.34
		25	12	25.68	25.48	25.51	23.21	23.29	23.24	25.28	25.31	25.43	22.74	22.88	22.78
		50	0	25.09	24.84	24.96	22.67	22.80	22.81	24.81	24.35	24.85	22.31	22.25	22.36
	16QAM	1	0	23.85	24.01	23.95	21.91	22.10	21.93	23.73	23.86	24.08	21.18	21.20	21.32
		1	1	25.23	25.36	24.95	22.97	22.93	22.94	25.19	25.14	25.10	22.56	22.18	22.39
		1	50	25.41	24.83	24.37	23.00	23.10	22.56	24.87	25.18	24.78	22.27	22.68	22.74
		1	51	24.20	24.26	23.57	21.75	21.87	21.44	23.94	23.72	23.61	21.15	21.41	21.24
		25	12	25.27	25.11	25.18	22.93	22.90	22.88	24.94	24.55	25.07	22.33	22.42	22.38
		50	0	24.30	24.08	24.07	21.90	21.88	21.86	23.92	23.65	24.04	21.31	21.39	21.38
	64QAM	1	0	23.65	23.59	23.58	21.30	21.22	21.23	22.84	22.73	23.12	20.29	20.32	20.33
		1	1	23.49	23.75	23.43	21.32	21.14	21.12	23.06	22.97	23.12	20.47	20.67	20.66
		1	50	23.93	23.41	23.30	21.38	21.30	21.15	23.06	23.08	22.78	20.39	20.53	20.55
		1	51	23.50	23.38	23.03	21.12	21.20	20.84	22.96	23.04	22.82	20.48	20.42	20.16
		25	12	23.75	23.55	23.61	21.40	21.42	21.40	23.35	23.33	23.57	20.89	20.91	20.88
		50	0	23.76	23.57	23.61	21.40	21.44	21.40	23.36	23.14	23.48	20.90	20.93	20.96
	256QAM	1	0	21.59	21.60	21.66	19.49	19.35	19.42	21.20	21.09	21.49	18.44	19.00	18.53
1		1	21.64	21.45	21.45	19.38	19.56	19.51	21.20	21.23	21.47	18.64	18.78	18.95	
1		50	21.62	21.43	21.83	19.31	19.22	19.35	21.15	21.17	21.38	18.65	18.91	18.95	
1		51	21.74	21.53	21.43	19.02	19.34	19.08	21.27	21.35	21.32	18.84	19.02	18.71	
25		12	21.73	21.73	21.66	19.43	19.38	19.36	21.35	21.34	21.52	18.88	19.04	18.93	
50		0	21.67	21.55	21.57	19.32	19.29	19.28	21.36	21.16	21.34	18.91	19.01	18.87	

OUTPUT POWER FOR 5G NR n25 (15.0 MHz)

Bandwidth (MHz)	Modulation	RB Allocation	RB Offset	Conducted Average (dBm)											
				ANT 1			ANT 2			ANT 3			ANT 4		
				371500	376500	381500	371500	376500	381500	371500	376500	381500	371500	376500	381500
15.0	BPSK	1	0	1857.5	1882.5	1907.5	1857.5	1882.5	1907.5	1857.5	1882.5	1907.5	1857.5	1882.5	1907.5
		1	1	25.70	25.55	25.54	23.36	23.32	23.40	25.28	25.18	25.38	22.83	22.87	22.79
		1	1	25.70	25.57	25.63	23.34	23.28	23.35	25.29	25.25	25.36	22.82	22.80	22.86
		1	77	25.63	25.58	25.68	23.21	23.36	23.30	25.19	25.35	25.50	22.85	22.79	22.82
		1	78	25.58	25.66	25.56	23.32	23.25	23.22	25.20	25.29	25.37	22.69	22.86	22.84
		36	18	25.44	25.45	25.43	23.09	23.14	23.14	25.11	25.05	25.29	22.63	22.74	22.71
	75	0	25.50	25.57	25.50	23.17	23.18	23.27	25.16	25.14	25.32	22.68	22.80	22.82	
	QPSK	1	0	25.29	25.30	25.10	22.87	22.93	22.81	24.88	24.77	25.00	22.42	22.63	22.59
		1	1	25.60	25.61	25.60	23.30	23.37	23.21	25.35	25.19	25.44	22.84	22.89	22.89
		1	77	25.58	25.65	25.25	23.21	23.26	23.04	25.25	25.29	25.43	22.74	22.90	22.83
		1	78	25.13	25.13	24.28	22.81	22.82	22.09	24.87	24.92	24.45	22.34	22.56	22.53
		36	18	25.48	25.57	25.49	23.21	23.22	23.25	25.21	25.11	25.31	22.70	22.83	22.79
		75	0	25.19	25.03	25.02	22.83	22.84	22.88	24.87	24.49	24.84	22.32	22.43	22.42
	16QAM	1	0	24.09	24.13	24.07	21.59	22.00	22.18	23.85	23.90	23.92	21.42	21.38	21.14
		1	1	25.32	25.08	25.35	22.78	22.75	23.18	24.78	24.87	25.14	22.64	22.49	22.59
		1	77	25.21	25.20	24.32	22.76	23.01	22.18	24.30	25.15	24.57	22.39	22.50	22.63
		1	78	24.39	24.10	23.57	21.94	21.92	21.50	23.81	23.84	23.64	21.22	21.48	21.37
		36	18	25.28	25.16	25.19	22.83	22.87	22.87	24.82	24.50	24.80	22.33	22.42	22.38
		75	0	24.10	24.14	24.21	21.77	21.87	21.85	23.89	23.76	23.94	21.36	21.45	21.44
	64QAM	1	0	23.69	23.70	23.58	21.25	21.17	21.45	23.03	23.00	23.21	20.50	20.67	20.53
		1	1	23.73	23.87	23.69	21.57	21.50	21.09	22.99	23.08	23.10	20.62	20.40	20.44
		1	77	23.50	23.48	22.87	21.05	21.11	20.98	23.26	22.95	23.04	20.38	20.79	20.86
		1	78	23.51	23.63	23.00	21.12	21.47	20.59	23.04	23.11	22.69	20.74	20.14	20.60
		36	18	23.69	23.63	23.66	21.30	21.32	21.32	23.35	23.20	23.49	20.88	20.91	21.04
		75	0	23.72	23.64	23.71	21.37	21.35	21.32	23.39	23.29	23.46	20.85	20.86	20.92
	256QAM	1	0	21.66	21.73	21.90	19.29	19.35	19.09	21.35	21.31	21.04	19.00	18.78	18.74
		1	1	21.88	21.86	21.68	19.45	19.49	19.45	21.28	21.09	21.51	18.94	18.71	18.99
		1	77	21.52	21.69	21.43	19.73	19.38	19.44	21.33	21.48	21.39	18.91	18.82	18.80
		1	78	21.75	21.51	21.52	19.43	19.47	19.46	21.38	21.13	21.26	19.02	18.61	18.75
		36	18	21.69	21.62	21.69	19.37	19.48	19.35	21.32	21.37	21.46	18.88	18.94	18.86
75		0	21.69	21.57	21.71	19.36	19.43	19.40	21.32	21.35	21.53	18.95	18.90	18.86	

OUTPUT POWER FOR 5G NR n25 (20.0 MHz)

Bandwidth (MHz)	Modulation	RB Allocation	RB Offset	Conducted Average (dBm)											
				ANT 1			ANT 2			ANT 3			ANT 4		
				372000	376500	381000	372000	376500	381000	372000	376500	381000	372000	376500	381000
20.0	BPSK	1	0	1860.0	1882.5	1905.0	1860.0	1882.5	1905.0	1860.0	1882.5	1905.0	1860.0	1882.5	1905.0
		1	1	25.63	25.49	25.55	23.16	23.22	23.17	25.35	25.34	25.31	22.86	22.77	22.76
		1	104	25.62	25.48	25.54	23.27	23.22	23.13	25.50	25.37	25.32	22.84	22.70	22.80
		1	105	25.51	25.70	25.69	23.24	23.21	23.11	25.41	25.36	25.40	22.89	22.77	22.81
		1	105	25.54	25.63	25.65	23.17	23.24	23.15	25.46	25.41	25.33	22.80	22.76	22.71
		50	25	25.52	25.52	25.61	23.10	23.23	23.17	25.39	25.37	25.40	22.79	22.82	22.79
	QPSK	100	0	25.53	25.54	25.50	23.16	23.25	23.16	25.39	25.29	25.39	22.81	22.80	22.83
		1	0	25.18	25.17	25.16	22.13	22.94	22.83	25.04	24.94	24.96	22.32	22.43	22.34
		1	1	25.53	25.57	25.60	23.04	23.32	23.26	25.37	25.42	25.39	22.81	22.90	22.77
		1	104	25.60	25.68	25.21	23.13	23.21	23.10	25.46	25.47	25.44	22.86	22.87	22.69
		1	105	25.11	24.95	24.30	21.96	22.83	22.76	24.91	24.95	24.57	22.42	22.45	22.48
		50	25	25.47	25.60	25.50	23.40	23.24	23.17	25.38	25.27	25.37	22.82	22.78	22.79
	16QAM	100	0	25.11	24.87	24.83	22.86	22.84	22.75	24.98	24.54	24.72	22.41	22.41	22.17
		1	0	24.21	23.95	24.23	20.48	21.77	21.82	24.06	23.74	23.76	21.52	21.25	21.31
		1	1	25.15	25.03	24.91	21.68	22.55	22.71	25.03	25.21	24.64	22.54	22.70	22.33
		1	104	24.96	24.95	24.19	21.77	23.16	22.71	24.83	24.74	24.98	22.61	22.64	22.25
		1	105	24.37	24.35	23.25	20.46	22.06	21.87	24.12	23.82	23.94	21.34	21.69	21.18
		50	25	25.07	24.98	25.15	23.10	22.75	22.79	24.98	24.68	25.02	22.42	22.38	22.38
	64QAM	100	0	24.12	24.11	24.12	21.99	21.85	21.78	23.86	23.76	24.03	21.40	21.40	21.43
		1	0	23.56	23.27	23.67	21.49	21.14	21.51	22.67	23.03	22.91	20.46	20.37	20.49
		1	1	23.67	23.50	23.48	21.45	21.51	21.17	23.01	23.13	23.09	20.50	20.68	20.42
		1	104	23.48	23.48	23.05	21.15	21.34	21.28	23.22	23.17	22.98	20.69	20.24	20.49
		1	105	23.65	23.54	23.02	21.25	21.38	21.08	23.20	23.35	22.99	20.57	20.56	20.31
		50	25	23.70	23.63	23.68	21.40	21.34	21.30	23.46	23.26	23.50	20.92	20.92	20.89
	256QAM	100	0	23.57	23.61	23.63	21.37	21.31	21.31	23.41	23.29	23.54	20.89	20.90	20.91
		1	0	21.55	21.70	21.79	19.50	19.49	19.35	21.43	21.46	21.46	18.92	18.69	18.62
		1	1	21.84	21.17	21.73	19.37	19.35	19.30	21.18	21.25	21.46	19.01	18.99	18.89
		1	104	21.61	21.87	21.53	19.40	19.40	19.29	21.30	21.19	21.26	18.99	18.68	18.82
		1	105	21.63	21.40	21.57	19.24	19.30	19.20	21.14	21.39	21.42	18.46	18.64	18.80
		50	25	21.62	21.58	21.62	19.28	19.20	19.22	21.40	21.29	21.44	18.87	18.85	18.92
100	0	21.65	21.61	21.64	19.36	19.28	19.28	21.37	21.26	21.45	18.82	18.86	18.91		

OUTPUT POWER FOR 5G NR n25 (25.0 MHz)

Bandwidth (MHz)	Modulation	RB Allocation	RB Offset	Conducted Average (dBm)											
				ANT 1			ANT 2			ANT 3			ANT 4		
				372500 1862.5	376500 1882.5	380500 1902.5	372500 1862.5	376500 1882.5	380500 1902.5	372500 1862.5	376500 1882.5	380500 1902.5	372500 1862.5	376500 1882.5	380500 1902.5
25.0	BPSK	1	0	25.70	25.64	25.55	23.24	23.31	23.34	25.30	25.25	25.46	22.60	22.58	22.73
		1	1	25.68	25.62	25.61	23.22	23.26	23.26	25.23	25.34	25.32	22.63	22.58	22.78
		1	132	25.54	25.67	25.62	23.28	23.32	23.40	25.27	25.35	25.50	22.63	22.90	22.79
		1	131	25.60	25.56	25.63	23.32	23.29	23.32	25.28	25.42	25.47	22.73	22.82	22.54
		64	32	25.58	25.55	25.50	23.21	23.32	23.27	25.22	25.25	25.47	22.46	22.83	22.69
	QPSK	128	0	25.62	25.58	25.51	23.29	23.30	23.27	25.24	25.25	23.90	22.49	22.84	22.22
		1	0	25.29	25.11	25.18	22.94	22.90	22.94	24.91	24.92	24.90	22.29	22.39	22.26
		1	1	25.70	25.62	25.42	23.25	23.25	23.35	25.23	25.33	25.38	22.63	22.52	22.74
		1	132	25.60	25.68	25.41	23.35	23.38	23.32	25.28	25.31	25.46	22.60	22.68	22.78
		1	131	25.20	25.22	24.41	22.83	22.91	22.89	24.90	24.93	24.76	22.22	22.10	22.34
	16QAM	64	32	25.66	25.57	25.51	23.35	23.31	23.36	25.23	25.23	25.41	22.49	22.71	22.63
		128	0	25.26	24.98	24.70	22.92	22.93	22.84	24.83	24.66	24.76	22.17	22.26	22.30
		1	0	24.45	24.07	24.26	21.94	21.87	21.78	23.82	23.79	23.97	21.11	21.47	21.36
		1	1	25.25	25.12	25.29	22.76	22.95	23.11	24.68	24.61	24.75	22.49	22.26	22.26
		1	132	25.11	24.94	24.46	22.72	22.80	22.93	24.65	25.04	24.97	21.98	22.06	22.13
	64QAM	1	131	24.48	24.42	23.62	22.04	21.89	21.91	23.96	24.19	23.98	20.75	20.87	21.50
		64	32	25.22	25.16	25.08	22.88	22.97	22.94	24.96	24.53	25.00	22.11	22.26	22.32
		128	0	24.22	24.18	24.12	21.91	21.96	21.93	23.86	23.80	23.85	21.09	21.25	21.24
		1	0	23.65	23.70	23.42	21.35	21.35	21.51	22.80	22.86	23.14	20.35	20.32	20.41
		1	1	23.76	23.56	23.66	21.52	21.43	21.58	22.93	22.76	22.97	20.31	20.55	20.59
	256QAM	1	132	23.55	23.65	23.28	21.27	21.54	21.23	22.90	23.01	22.91	20.22	20.35	20.49
		1	131	23.71	23.64	23.16	21.37	21.62	21.30	22.98	23.14	22.82	20.06	20.40	20.32
		64	32	23.66	23.57	23.60	21.42	21.33	21.46	23.43	23.31	23.39	20.59	20.82	20.68
		128	0	23.74	23.63	23.55	21.42	21.41	21.45	23.41	23.36	23.47	20.58	20.78	20.74
		1	0	21.69	21.76	21.72	19.33	19.43	19.48	21.21	21.24	21.13	18.49	18.55	18.65
	256QAM	1	1	22.08	21.83	21.96	19.58	19.69	19.45	21.28	21.21	21.27	18.85	18.76	18.86
		1	132	21.29	21.53	21.75	19.51	19.33	19.32	21.24	21.42	21.45	18.78	18.67	18.55
		1	131	21.77	21.71	21.74	19.43	19.51	19.15	21.14	21.17	21.17	18.72	18.62	18.73
		64	32	21.69	21.59	21.65	19.35	19.44	19.37	21.44	21.38	21.40	18.57	18.82	18.89
		128	0	21.68	21.60	21.66	19.37	19.32	19.43	21.30	21.38	21.38	18.55	18.80	18.90

OUTPUT POWER FOR 5G NR n25 (30.0 MHz)

Bandwidth (MHz)	Modulation	RB Allocation	RB Offset	Conducted Average (dBm)											
				ANT 1			ANT 2			ANT 3			ANT 4		
				373000 1865.0	376500 1882.5	380000 1900.0	373000 1865.0	376500 1882.5	380000 1900.0	373000 1865.0	376500 1882.5	380000 1900.0	373000 1865.0	376500 1882.5	380000 1900.0
30.0	BPSK	1	0	25.60	25.58	25.53	23.12	23.22	23.26	25.24	25.23	25.32	22.77	22.69	22.83
		1	1	25.67	25.70	25.55	23.18	23.21	23.40	25.32	25.26	25.32	22.76	22.67	22.90
		1	158	25.55	25.54	25.63	23.23	23.30	23.30	25.32	25.31	25.50	22.87	22.83	22.69
		1	159	25.51	25.64	25.55	23.23	23.20	23.24	25.23	25.32	25.46	22.83	22.80	22.70
		80	40	25.59	25.57	25.49	23.12	23.27	23.21	25.26	25.26	25.33	22.71	22.89	22.81
	QPSK	160	0	25.64	25.61	25.51	23.20	23.27	23.27	25.25	25.29	25.32	22.79	22.79	22.86
		1	0	25.26	25.23	24.94	22.78	22.88	22.85	24.92	24.81	24.85	22.29	22.32	22.43
		1	1	25.59	25.54	25.60	23.14	23.36	23.35	25.41	25.22	25.29	22.81	22.67	22.88
		1	158	25.62	25.68	25.45	23.27	23.23	23.32	25.35	25.31	25.43	22.90	22.69	22.80
		1	159	25.16	25.20	24.46	22.84	22.82	22.81	24.91	24.93	24.54	22.43	22.41	22.25
	16QAM	80	40	25.65	25.56	25.51	23.17	23.21	23.18	25.27	25.27	25.31	22.75	22.79	22.77
		160	0	25.22	25.02	25.08	22.92	22.81	22.85	24.87	24.84	24.24	22.39	22.39	22.32
		1	0	24.49	24.40	24.11	21.79	21.94	21.86	23.88	23.90	23.84	21.19	21.32	21.45
		1	1	25.24	25.29	25.26	22.91	22.66	22.53	25.02	25.06	24.86	22.40	21.77	22.27
		1	158	25.16	25.32	24.82	22.58	23.00	22.61	24.80	24.79	24.42	22.49	22.26	22.47
	64QAM	1	159	23.88	24.10	23.58	21.74	22.25	22.07	24.17	23.68	23.76	21.56	21.30	21.11
		80	40	25.21	25.07	25.03	22.86	22.78	22.91	24.94	24.69	24.97	22.36	22.39	22.43
		160	0	24.22	24.13	24.07	21.86	21.82	21.88	23.89	23.86	23.58	21.34	21.41	21.42
		1	0	23.75	23.42	23.69	20.96	21.59	21.18	22.99	22.99	23.08	20.53	20.39	20.63
		1	1	23.64	23.59	23.47	21.10	21.13	21.31	22.77	23.06	22.81	20.59	20.28	20.61
	256QAM	1	158	23.47	23.66	22.95	21.36	21.53	21.56	22.75	22.93	23.09	20.72	20.31	20.25
		1	159	23.43	23.76	23.28	21.32	21.50	21.15	23.07	23.02	23.02	20.56	20.40	20.41
		80	40	23.65	23.67	23.54	21.41	21.47	21.40	23.37	23.36	23.51	20.83	20.96	20.91
		160	0	23.71	23.64	23.58	21.37	21.48	21.41	23.43	23.40	23.56	20.91	20.87	20.95
		1	0	21.96	22.03	21.67	19.25	19.64	19.47	21.39	21.33	21.22	18.81	18.90	19.16
	256QAM	1	1	21.76	22.00	21.40	19.23	19.40	19.64	21.23	21.02	21.68	18.79	18.84	19.13
		1	158	21.64	21.61	21.71	19.51	19.51	19.44	21.07	21.34	21.39	18.85	18.99	18.64
		1	159	21.35	21.44	21.50	19.51	19.41	19.29	21.26	21.54	21.56	19.13	18.95	18.76
		80	40	21.66	21.57	21.60	19.34	19.35	19.33	21.34	21.40	21.50	18.84	18.95	18.85
		160	0	21.69	21.63	21.63	19.33	19.40	19.40	21.35	21.38	21.53	18.86	18.97	18.95

OUTPUT POWER FOR 5G NR n25 (35.0 MHz)

Bandwidth (MHz)	Modulation	RB Allocation	RB Offset	Conducted Average (dBm)											
				ANT 1			ANT 2			ANT 3			ANT 4		
				373500	376500	397500	373500	376500	397500	373500	376500	397500	373500	376500	397500
35.0	BPSK	1	0	25.58	25.47	25.59	23.36	23.10	23.30	25.23	25.24	25.29	22.48	22.60	22.81
		1	1	25.55	25.43	25.64	23.40	23.10	23.24	25.36	25.29	25.22	22.63	22.56	22.81
		1	158	25.68	25.45	25.61	23.36	23.22	23.24	25.45	25.37	25.41	22.71	22.69	22.79
		1	159	25.68	25.43	25.67	23.36	23.25	23.34	25.42	25.35	25.45	22.80	22.66	22.90
		80	40	25.44	25.32	25.54	23.08	23.19	23.22	25.28	25.22	25.29	22.54	22.67	22.63
		160	0	25.51	25.37	25.57	23.19	23.24	23.28	22.80	24.62	25.35	22.58	22.75	22.69
	QPSK	1	0	25.23	25.00	25.18	22.86	22.78	22.90	24.89	24.85	24.93	22.33	22.21	22.37
		1	1	25.65	25.54	25.49	23.34	23.18	23.24	25.41	25.18	25.24	22.85	22.59	22.68
		1	158	25.66	25.62	25.70	23.36	23.24	23.25	25.28	25.34	25.50	22.83	22.66	22.68
		1	159	25.19	25.08	24.80	23.04	22.98	22.80	24.93	25.04	24.44	22.36	22.28	22.38
		80	40	25.56	25.45	25.55	23.12	23.17	23.25	25.35	25.26	25.29	22.64	22.73	22.72
		160	0	25.18	25.05	25.17	22.84	22.81	22.87	24.52	24.35	24.77	22.34	22.19	22.36
	16QAM	1	0	24.23	23.81	24.22	21.71	21.93	21.99	24.20	23.95	23.72	21.50	21.38	21.49
		1	1	25.33	24.74	24.98	22.70	22.80	22.93	24.90	24.85	24.59	22.30	22.25	21.90
		1	158	25.19	25.28	25.17	23.04	22.82	23.00	24.61	25.12	24.90	22.08	22.22	22.68
		1	159	24.29	23.90	23.88	22.08	21.72	21.78	23.79	24.21	23.59	21.24	21.46	21.60
		80	40	25.12	25.08	25.14	22.72	22.73	22.82	24.95	24.73	24.92	22.29	22.28	22.32
		160	0	24.12	24.11	24.10	21.84	21.79	21.91	23.92	23.91	23.78	21.31	21.31	21.38
	64QAM	1	0	23.86	23.67	23.49	21.47	21.06	21.53	22.95	23.11	22.90	20.86	20.65	20.91
		1	1	23.70	23.60	23.75	21.46	21.28	21.47	22.85	23.05	22.87	20.88	20.75	20.93
		1	158	23.64	23.53	23.41	21.59	21.33	21.36	23.16	23.13	23.24	21.06	20.97	21.01
		1	159	23.71	23.35	23.49	21.56	21.48	21.46	22.90	23.23	22.85	21.02	21.07	20.89
		80	40	23.58	23.57	23.52	21.24	21.26	21.32	23.39	23.37	23.43	20.80	20.80	20.87
		160	0	23.61	23.61	23.60	21.31	21.31	21.42	23.43	23.45	23.46	20.79	20.83	20.90
	256QAM	1	0	21.77	21.51	21.60	19.39	19.22	19.28	21.13	21.41	21.41	18.64	18.67	18.92
		1	1	21.78	21.74	21.54	19.17	19.28	19.38	21.41	21.70	21.38	18.81	18.99	18.88
		1	158	21.41	21.72	21.89	19.25	19.45	18.96	21.32	21.51	21.20	19.15	18.68	18.90
		1	159	21.77	21.65	21.63	19.05	19.56	19.26	21.41	21.68	21.55	19.14	18.85	19.23
		80	40	21.50	21.58	21.55	19.16	19.27	19.39	21.31	21.31	21.41	18.73	18.75	18.93
		160	0	21.53	21.59	21.58	19.24	19.33	19.45	21.36	21.39	21.50	18.71	18.81	18.98

OUTPUT POWER FOR 5G NR n25 (40.0 MHz)

Bandwidth (MHz)	Modulation	RB Allocation	RB Offset	Conducted Average (dBm)											
				ANT 1			ANT 2			ANT 3			ANT 4		
				374000	376500	379000	374000	376500	379000	374000	376500	379000	374000	376500	379000
40.0	BPSK	1	0	25.59	25.62	25.57	23.16	23.29	23.22	25.07	25.08	25.15	22.62	22.48	22.56
		1	1	25.67	25.70	25.60	23.20	23.35	23.30	25.37	25.34	25.42	22.78	22.51	22.61
		1	214	25.62	25.63	25.70	23.35	23.36	23.16	25.44	25.41	25.39	22.90	22.68	22.55
		1	215	25.60	25.63	25.57	23.22	23.38	23.26	25.30	25.19	25.23	22.77	22.64	22.53
		108	54	25.48	25.55	25.53	23.27	23.26	23.20	25.27	25.33	25.39	22.70	22.73	22.53
		216	0	25.60	25.64	25.64	23.28	23.29	23.40	22.22	21.92	25.13	20.77	22.72	22.59
	QPSK	1	0	25.25	25.28	25.17	22.87	22.77	22.96	24.62	24.61	24.60	22.29	22.20	22.14
		1	1	25.69	25.67	25.69	23.24	23.18	23.21	25.32	25.32	25.44	22.74	22.53	22.54
		1	214	25.56	25.58	25.51	23.26	23.38	23.32	25.35	25.50	25.37	22.71	22.64	22.48
		1	215	24.98	25.13	24.58	22.87	22.91	22.91	24.74	24.62	24.41	22.23	22.35	22.15
		108	54	25.56	25.63	25.55	23.33	23.31	23.28	25.31	25.40	25.44	22.65	22.73	22.52
		216	0	25.14	25.10	25.27	22.93	22.88	22.91	24.36	24.53	24.75	22.31	22.35	22.22
	16QAM	1	0	24.26	24.29	24.15	22.17	21.82	22.01	23.63	23.48	23.76	21.37	20.98	21.27
		1	1	25.27	25.28	25.23	22.82	22.67	22.96	24.14	24.41	24.74	22.45	22.26	21.87
		1	214	25.04	25.23	24.76	23.00	23.01	22.69	24.66	24.70	24.85	22.22	22.49	22.23
		1	215	24.26	24.62	23.41	21.86	21.98	21.74	23.83	23.65	23.22	21.20	21.39	20.89
		108	54	25.15	25.18	25.20	22.89	22.89	22.89	24.68	24.67	24.74	22.28	22.34	22.19
		216	0	24.14	24.21	24.30	21.88	21.90	21.88	23.64	23.73	23.73	21.31	21.42	21.21
	64QAM	1	0	23.64	23.91	23.62	21.31	21.35	21.38	23.34	22.91	23.52	20.42	20.55	20.30
		1	1	23.62	23.75	23.68	21.20	21.14	21.18	23.27	23.14	23.53	20.20	20.26	20.23
		1	214	23.49	23.83	23.22	21.57	21.08	21.43	23.33	23.40	23.01	20.29	20.25	20.33
		1	215	23.42	23.46	23.16	21.30	21.16	21.17	23.38	23.30	23.27	20.38	20.31	20.45
		108	54	23.68	23.58	23.64	21.35	21.26	21.32	23.17	23.19	23.18	20.77	20.83	20.77
		216	0	23.59	23.67	23.72	21.35	21.32	21.43	23.23	23.20	23.20	20.84	20.85	20.73
	256QAM	1	0	21.87	21.85	21.59	19.52	19.37	19.46	21.06	21.08	20.95	18.71	18.60	18.60
		1	1	21.69	21.93	21.77	19.37	19.47	19.41	21.00	20.85	21.34	18.82	18.68	18.66
		1	214	21.74	21.87	21.83	19.67	19.57	19.51	21.01	21.19	21.21	18.77	18.82	18.93
		1	215	21.90	21.83	21.60	19.71	19.51	19.45	21.19	21.23	21.12	18.69	18.67	18.69
		108	54	21.74	21.65	21.67	19.34	19.42	19.40	21.10	21.13	21.10	18.72	18.68	18.88
		216	0	21.65	21.71	21.73	19.40	19.47	19.44	21.10	21.13	21.11	18.77	18.77	18.89

8.7. LTE BAND 26 AND 5G NR n26 (FCC Part 90S)

LTE BAND 26

Test Engineer ID:	32061	Test Date:	2024-03-09
-------------------	-------	------------	------------

OUTPUT POWER FOR LTE BAND 26 (1.4 MHz)

Bandwidth (MHz)	Modulation	RB Allocation	RB Offset	Conducted Average (dBm)					
				ANT 1			ANT 2		
				26697	26740	26783	26697	26740	26783
1.4	QPSK	1	0	25.57	25.58	25.62	25.17	25.19	25.03
		1	2	25.56	25.70	25.66	25.18	25.20	25.07
		1	5	25.63	25.66	25.64	25.16	25.10	25.04
		3	0	25.54	25.64	25.63	25.15	25.03	25.02
		3	1	25.67	25.63	25.65	25.18	25.05	25.03
		3	2	25.66	25.63	25.66	25.16	25.01	25.00
	16QAM	6	0	25.21	25.22	25.22	24.25	24.10	24.12
		1	0	25.26	25.30	25.41	24.37	24.22	24.19
		1	2	25.35	25.40	25.39	24.45	24.26	24.33
		1	5	25.36	25.39	25.42	24.37	24.21	24.32
		3	0	25.26	25.35	25.30	24.38	24.23	24.21
		3	1	25.34	25.37	25.30	24.36	24.25	24.22
	64QAM	3	2	25.35	25.35	25.29	24.40	24.21	24.22
		6	0	24.35	24.26	24.28	23.28	23.21	23.12
		1	0	24.43	24.41	24.35	23.37	23.41	23.24
		1	2	24.50	24.59	24.42	23.46	23.48	23.33
		1	5	24.55	24.51	24.44	23.35	23.33	23.30
		3	0	24.36	24.36	24.33	23.41	23.20	23.29
	256QAM	3	1	24.42	24.38	24.34	23.43	23.17	23.28
		3	2	24.37	24.36	24.36	23.43	23.23	23.27
		6	0	23.42	23.25	23.30	22.22	22.17	22.18
		1	0	21.37	21.29	21.30	20.30	20.31	20.15
		1	2	21.38	21.37	21.30	20.30	20.35	20.21
		1	5	21.43	21.33	21.28	20.28	20.36	20.18
3	QPSK	3	0	21.29	21.36	21.26	20.25	20.10	20.21
		3	1	21.38	21.37	21.27	20.27	20.09	20.22
		3	2	21.39	21.37	21.29	20.25	20.14	20.22
		6	0	21.30	21.20	21.25	20.30	20.13	20.17

OUTPUT POWER FOR LTE BAND 26 (3.0 MHz)

Bandwidth (MHz)	Modulation	RB Allocation	RB Offset	Conducted Average (dBm)					
				ANT 1			ANT 2		
				26705	26740	26775	26705	26740	26775
3.0	QPSK	1	0	25.56	25.59	25.56	25.12	25.11	25.12
		1	7	25.70	25.68	25.63	25.14	25.17	25.20
		1	14	25.55	25.53	25.53	25.06	25.09	25.09
		8	0	25.29	25.26	25.25	24.22	24.27	24.31
		8	4	25.31	25.27	25.25	24.25	24.30	24.31
		8	7	25.29	25.28	25.25	24.23	24.31	24.29
	16QAM	15	0	25.24	25.20	25.24	24.21	24.25	24.28
		1	0	25.33	25.29	25.41	24.30	24.45	24.42
		1	7	25.46	25.44	25.45	24.45	24.51	24.52
		1	14	25.30	25.31	25.46	24.33	24.34	24.39
		8	0	24.29	24.28	24.25	23.24	23.27	23.35
		8	4	24.32	24.31	24.27	23.29	23.35	23.37
	64QAM	8	7	24.32	24.30	24.27	23.31	23.31	23.38
		15	0	24.25	24.25	24.24	23.21	23.26	23.29
		1	0	24.49	24.48	24.51	23.58	23.57	23.64
		1	7	24.58	24.59	24.59	23.59	23.58	23.64
		1	14	24.48	24.55	24.61	23.45	23.70	23.50
		8	0	23.22	23.32	23.30	22.38	22.35	22.36
	256QAM	8	4	23.26	23.32	23.33	22.40	22.41	22.40
		8	7	23.28	23.34	23.31	22.39	22.37	22.40
		15	0	23.26	23.24	23.25	22.27	22.31	22.34
		1	0	21.27	21.22	21.20	20.26	20.27	20.39
		1	7	21.42	21.34	21.33	20.35	20.32	20.43
		1	14	21.33	21.28	21.18	20.33	20.26	20.38
3	QPSK	8	0	21.26	21.26	21.26	20.28	20.29	20.33
		8	4	21.30	21.30	21.30	20.32	20.33	20.36
		8	7	21.31	21.27	21.30	20.31	20.32	20.34
		15	0	21.28	21.24	21.24	20.26	20.26	20.33

OUTPUT POWER FOR LTE BAND 26 (5.0 MHz)

Bandwidth (MHz)	Modulation	RB Allocation	RB Offset	Conducted Average (dBm)					
				ANT 1			ANT 2		
				26715	26740	26765	26715	26740	26765
5.0	QPSK	1	0	25.56	25.56	25.54	25.05	25.08	25.05
		1	12	25.70	25.67	25.67	25.12	25.20	25.20
		1	24	25.56	25.58	25.53	25.01	25.02	25.03
		12	0	25.14	25.15	25.14	24.17	24.18	24.12
		12	6	25.25	25.22	25.25	24.18	24.20	24.22
		12	11	25.23	25.22	25.23	24.17	24.17	24.17
		25	0	25.24	25.21	25.20	24.16	24.20	24.20
	16QAM	1	0	25.39	25.44	25.42	24.29	24.36	24.40
		1	12	25.46	25.50	25.46	24.45	24.42	24.52
		1	24	25.33	25.41	25.40	24.37	24.35	24.35
		12	0	24.23	24.07	24.10	23.11	23.22	23.10
		12	6	24.36	24.18	24.20	23.16	23.23	23.21
		12	11	24.29	24.13	24.19	23.11	23.19	23.18
		25	0	24.22	24.24	24.21	23.17	23.17	23.21
	64QAM	1	0	24.43	24.44	24.34	23.45	23.40	23.41
		1	12	24.54	24.57	24.52	23.42	23.53	23.57
		1	24	24.48	24.53	24.46	23.36	23.45	23.45
		12	0	23.15	23.18	23.11	22.14	22.28	22.13
		12	6	23.25	23.28	23.24	22.17	22.31	22.24
		12	11	23.25	23.26	23.19	22.15	22.27	22.22
		25	0	23.24	23.24	23.21	22.19	22.20	22.21
	256QAM	1	0	21.30	21.25	21.19	20.17	20.19	20.27
		1	12	21.35	21.31	21.36	20.23	20.34	20.30
		1	24	21.28	21.30	21.26	20.25	20.25	20.43
		12	0	21.17	21.14	21.12	20.22	20.19	20.15
		12	6	21.23	21.26	21.24	20.24	20.23	20.26
		12	11	21.22	21.22	21.17	20.21	20.15	20.23
		25	0	21.23	21.21	21.18	20.18	20.19	20.21

OUTPUT POWER FOR LTE BAND 26 (10.0 MHz)

Bandwidth (MHz)	Modulation	RB Allocation	RB Offset	Conducted Average (dBm)					
				ANT 1			ANT 2		
				N/A	26740	N/A	N/A	26740	N/A
10.0	QPSK	1	0		25.69			25.20	
		1	24		25.70			25.20	
		1	49		25.64			25.12	
		25	0		25.26			24.22	
		25	12		25.35			24.31	
		25	24		25.31			24.26	
		50	0		25.33			24.29	
	16QAM	1	0		25.53			24.48	
		1	24		25.46			24.47	
		1	49		25.41			24.40	
		25	0		24.27			23.23	
		25	12		24.38			23.32	
		25	24		24.33			23.25	
		50	0		24.35			23.30	
	64QAM	1	0		24.57			23.57	
		1	24		24.57			23.49	
		1	49		24.54			23.49	
		25	0		23.29			22.20	
		25	12		23.37			22.32	
		25	24		23.36			22.27	
		50	0		23.38			22.30	
	256QAM	1	0		21.26			20.32	
		1	24		21.40			20.39	
		1	49		21.41			20.38	
		25	0		21.27			20.21	
		25	12		21.35			20.30	
		25	24		21.33			20.25	
		50	0		21.34			20.28	

5G NR n26

Test Engineer ID:	12482	Test Date:	2024-02-24
--------------------------	-------	-------------------	------------

OUTPUT POWER FOR 5G NR n26 (5.0 MHz)

Bandwidth (MHz)	Modulation	RB Allocation	RB Offset	Conducted Average (dBm)					
				ANT 1			ANT 2		
				163300	163800	164300	163300	163800	164300
5.0	BPSK	1	0	24.20	25.62	25.57	23.70	25.09	25.02
		1	1	25.67	25.70	25.60	25.00	25.15	25.10
		1	23	25.62	25.63	25.70	25.15	25.16	24.96
		1	24	24.20	25.63	25.57	23.70	25.18	25.06
		12	6	25.48	25.55	25.53	25.07	25.06	25.00
		25	0	25.60	25.64	25.64	25.08	25.09	25.20
	QPSK	1	0	24.20	25.28	25.17	23.70	24.57	24.76
		1	1	25.69	25.67	25.69	25.04	24.98	25.01
		1	23	25.56	25.58	25.51	25.06	25.18	25.12
		1	24	24.20	25.13	24.58	23.70	24.71	24.71
		12	6	25.56	25.63	25.55	25.13	25.11	25.08
		25	0	25.14	25.10	25.27	24.73	24.68	24.71
	16QAM	1	0	24.26	24.29	24.15	23.97	23.62	23.81
		1	1	25.27	25.28	25.23	24.62	24.47	24.76
		1	23	25.04	25.23	24.76	24.80	24.81	24.49
		1	24	24.26	24.62	23.41	23.66	23.78	23.54
		12	6	25.15	25.18	25.20	24.69	24.69	24.69
		25	0	24.14	24.21	24.30	23.68	23.70	23.68
	64QAM	1	0	23.64	23.91	23.62	23.11	23.15	23.18
		1	1	23.62	23.75	23.68	23.00	22.94	22.98
		1	23	23.49	23.83	23.22	23.37	22.88	23.23
		1	24	23.42	23.46	23.16	23.10	22.96	22.97
		12	6	23.68	23.58	23.64	23.15	23.06	23.12
		25	0	23.59	23.67	23.72	23.15	23.12	23.23
	256QAM	1	0	21.87	21.85	21.59	21.32	21.17	21.26
		1	1	21.69	21.93	21.77	21.17	21.27	21.21
		1	23	21.74	21.87	21.83	21.47	21.37	21.31
		1	24	21.90	21.83	21.60	21.51	21.31	21.25
		12	6	21.74	21.65	21.67	21.14	21.22	21.20
		25	0	21.65	21.71	21.73	21.20	21.27	21.24

OUTPUT POWER FOR 5G NR n26 (10.0 MHz)

Bandwidth (MHz)	Modulation	RB Allocation	RB Offset	Conducted Average (dBm)					
				ANT 1			ANT 2		
				N/A	163800	N/A	N/A	163800	N/A
10.0	BPSK	1	0		25.58			25.11	
		1	1		25.70			25.15	
		1	50		25.56			25.03	
		1	51		25.48			24.97	
		25	12		25.55			25.08	
		50	0		25.60			25.09	
	QPSK	1	0		24.99			24.74	
		1	1		25.59			25.20	
		1	50		25.53			25.04	
		1	51		25.10			24.67	
		25	12		25.57			25.13	
		50	0		24.95			24.72	
	16QAM	1	0		23.93			23.65	
		1	1		24.89			25.08	
		1	50		24.83			24.77	
		1	51		24.28			23.67	
		25	12		24.93			24.72	
		50	0		24.07			23.69	
	64QAM	1	0		23.33			23.25	
		1	1		23.45			23.19	
		1	50		23.28			23.12	
		1	51		23.48			22.95	
		25	12		23.55			23.26	
		50	0		23.62			23.29	
	256QAM	1	0		21.93			21.56	
		1	1		21.93			21.59	
		1	50		21.75			21.49	
		1	51		21.66			21.43	
		25	12		21.69			21.15	
		50	0		21.69			21.19	

8.8. LTE BAND 26 AND 5G NR n26 (FCC Part 22)

LTE BAND 26

Test Engineer ID:	32061	Test Date:	2024-03-09
-------------------	-------	------------	------------

OUTPUT POWER FOR LTE BAND 26 (1.4 MHz)

Bandwidth (MHz)	Modulation	RB Allocation	RB Offset	Conducted Average (dBm)					
				ANT 1			ANT 2		
				26797	26915	27033	26797	26915	27033
1.4	QPSK	1	0	25.65	25.58	25.67	25.18	24.93	25.11
		1	2	25.69	25.59	25.70	25.17	25.05	25.12
		1	5	25.64	25.64	25.66	25.20	25.03	25.05
		3	0	25.58	25.52	25.68	24.97	24.92	25.11
		3	1	25.58	25.54	25.70	24.97	24.92	25.13
		3	2	25.56	25.56	25.69	24.95	24.99	25.13
	16QAM	6	0	25.16	25.10	25.07	24.03	24.08	24.18
		1	0	25.32	25.30	25.29	24.19	24.20	24.29
		1	2	25.36	25.32	25.27	24.19	24.25	24.37
		1	5	25.29	25.36	25.02	24.20	24.24	24.29
		3	0	25.27	25.18	25.27	24.12	24.11	24.25
		3	1	25.31	25.22	25.20	24.12	24.16	24.26
	64QAM	3	2	25.28	25.22	25.04	24.15	24.21	24.28
		6	0	24.07	24.06	24.10	23.16	23.19	23.14
		1	0	24.43	24.24	24.42	23.21	23.27	23.46
		1	2	24.52	24.38	24.52	23.24	23.49	23.56
		1	5	24.42	24.29	24.31	23.15	23.42	23.48
		3	0	24.33	24.19	24.36	23.20	23.16	23.32
	256QAM	3	1	24.30	24.24	24.36	23.19	23.13	23.33
		3	2	24.29	24.23	24.29	23.19	23.24	23.31
		6	0	23.23	23.11	23.37	22.09	22.16	22.26
		1	0	21.34	21.20	21.32	20.11	19.97	20.17
		1	2	21.36	21.26	21.37	20.17	20.12	20.25
		1	5	21.31	21.22	21.29	20.07	20.18	20.27
256QAM	3	0	21.17	21.22	21.31	19.99	20.02	20.37	
	3	1	21.15	21.20	21.31	20.01	20.03	20.38	
	3	2	21.15	21.17	21.31	19.99	20.14	20.36	
	6	0	21.05	21.06	21.14	19.99	20.08	20.21	

OUTPUT POWER FOR LTE BAND 26 (3.0 MHz)

Bandwidth (MHz)	Modulation	RB Allocation	RB Offset	Conducted Average (dBm)					
				ANT 1			ANT 2		
				26805	26915	27025	26805	26915	27025
3.0	QPSK	1	0	25.56	25.45	25.64	24.96	24.89	25.16
		1	7	25.58	25.64	25.70	25.07	25.07	25.20
		1	14	25.47	25.50	25.55	24.91	24.99	25.09
		8	0	25.17	25.09	25.26	24.10	24.05	24.26
		8	4	25.19	25.17	25.30	24.16	24.08	24.29
		8	7	25.18	25.21	25.28	24.17	24.17	24.29
	16QAM	15	0	25.13	25.10	25.27	24.08	24.14	24.23
		1	0	25.30	25.21	25.55	24.21	24.22	24.34
		1	7	25.40	25.36	25.50	24.29	24.32	24.47
		1	14	25.29	25.35	25.33	24.20	24.36	24.38
		8	0	24.19	24.15	24.27	23.14	23.12	23.32
		8	4	24.20	24.18	24.31	23.20	23.10	23.33
	64QAM	8	7	24.22	24.28	24.29	23.17	23.22	23.32
		15	0	24.16	24.12	24.26	23.10	23.16	23.29
		1	0	24.44	24.39	24.49	23.36	23.45	23.56
		1	7	24.51	24.51	24.58	23.41	23.45	23.64
		1	14	24.38	24.42	24.50	23.38	23.41	23.43
		8	0	23.26	23.20	23.29	22.19	22.16	22.33
	256QAM	8	4	23.30	23.28	23.35	22.22	22.17	22.38
		8	7	23.30	23.35	23.33	22.21	22.26	22.35
		15	0	23.21	23.16	23.26	22.13	22.18	22.30
		1	0	21.21	21.17	21.31	20.06	20.14	20.39
		1	7	21.37	21.34	21.45	20.25	20.29	20.44
		1	14	21.17	21.30	21.32	20.06	20.21	20.37
256QAM	8	0	21.19	21.14	21.24	20.12	20.07	20.31	
	8	4	21.24	21.17	21.31	20.16	20.12	20.35	
	8	7	21.23	21.26	21.30	20.16	20.18	20.36	
	15	0	21.18	21.11	21.27	20.08	20.13	20.32	

OUTPUT POWER FOR LTE BAND 26 (5.0 MHz)

Bandwidth (MHz)	Modulation	RB Allocation	RB Offset	Conducted Average (dBm)					
				ANT 1			ANT 2		
				26815	26915	27015	26815	26915	27015
5.0	QPSK	1	0	25.45	25.46	25.57	24.91	24.96	25.13
		1	12	25.57	25.60	25.70	25.05	25.10	25.20
		1	24	25.45	25.49	25.55	24.91	25.00	25.09
		12	0	25.09	25.03	25.15	24.00	23.99	24.16
		12	6	25.12	25.07	25.23	24.12	24.05	24.30
		12	11	25.11	25.12	25.21	24.09	24.07	24.27
		25	0	25.10	25.05	25.11	24.06	24.13	24.16
	16QAM	1	0	25.21	25.31	25.35	24.23	24.32	24.42
		1	12	25.40	25.46	25.45	24.30	24.38	24.47
		1	24	25.26	25.29	25.30	24.18	24.31	24.45
		12	0	24.20	24.04	24.15	23.09	23.06	23.19
		12	6	24.22	24.07	24.21	23.19	23.10	23.29
		12	11	24.18	24.14	24.17	23.14	23.15	23.26
		25	0	24.12	24.07	24.12	23.05	23.15	23.16
	64QAM	1	0	24.36	24.35	24.42	23.34	23.35	23.51
		1	12	24.38	24.42	24.49	23.42	23.46	23.61
		1	24	24.32	24.45	24.42	23.32	23.37	23.51
		12	0	23.11	23.17	23.15	22.02	21.94	22.21
		12	6	23.17	23.23	23.25	22.11	21.99	22.33
		12	11	23.12	23.27	23.25	22.08	22.05	22.28
		25	0	23.10	23.08	23.15	22.04	22.14	22.22
	256QAM	1	0	21.12	21.21	21.26	20.10	20.14	20.17
		1	12	21.20	21.40	21.34	20.21	20.34	20.48
		1	24	21.22	21.18	21.19	20.22	20.16	20.41
		12	0	21.10	21.04	21.11	19.98	20.03	20.20
		12	6	21.12	21.08	21.25	20.10	20.06	20.31
		12	11	21.09	21.15	21.19	20.07	20.10	20.25
		25	0	21.08	21.09	21.11	20.06	20.13	20.19

OUTPUT POWER FOR LTE BAND 26 (10.0 MHz)

Bandwidth (MHz)	Modulation	RB Allocation	RB Offset	Conducted Average (dBm)					
				ANT 1			ANT 2		
				26840	26915	26990	26840	26915	26990
10.0	QPSK	1	0	25.59	25.61	25.63	25.00	24.97	25.10
		1	24	25.59	25.59	25.70	25.00	25.07	25.20
		1	49	25.56	25.60	25.65	24.93	25.09	25.12
		25	0	25.11	25.15	25.21	24.04	24.08	24.22
		25	12	25.22	25.20	25.26	24.13	24.13	24.25
		25	24	25.18	25.26	25.30	24.08	24.20	24.30
		50	0	25.19	25.16	25.25	24.09	24.17	24.21
	16QAM	1	0	25.36	25.43	25.47	24.21	24.18	24.27
		1	24	25.32	25.40	25.47	24.22	24.24	24.49
		1	49	25.34	25.46	25.44	24.24	24.32	24.33
		25	0	24.14	24.18	24.23	23.06	23.11	23.21
		25	12	24.23	24.20	24.24	23.13	23.14	23.23
		25	24	24.20	24.25	24.29	23.08	23.20	23.33
		50	0	24.23	24.18	24.22	23.11	23.18	23.21
	64QAM	1	0	24.54	24.47	24.53	23.44	23.37	23.51
		1	24	24.60	24.49	24.55	23.41	23.50	23.53
		1	49	24.47	24.52	24.51	23.33	23.49	23.58
		25	0	23.15	23.17	23.21	22.04	22.11	22.24
		25	12	23.23	23.20	23.26	22.12	22.14	22.28
		25	24	23.22	23.29	23.32	22.08	22.22	22.34
		50	0	23.23	23.18	23.24	22.07	22.21	22.21
	256QAM	1	0	21.16	21.18	21.36	20.10	20.19	20.24
		1	24	21.28	21.29	21.47	20.19	20.36	20.51
		1	49	21.30	21.33	21.35	20.15	20.45	20.43
		25	0	21.13	21.17	21.23	20.02	20.10	20.23
		25	12	21.21	21.19	21.25	20.11	20.15	20.30
		25	24	21.18	21.24	21.30	20.07	20.22	20.33
		50	0	21.20	21.15	21.23	20.09	20.20	20.25

5G NR n26

Test Engineer ID:	25780	Test Date:	2024-02-27
-------------------	-------	------------	------------

OUTPUT POWER FOR 5G NR n26 (5.0 MHz)

Bandwidth (MHz)	Modulation	RB Allocation	RB Offset	Conducted Average (dBm)					
				ANT 1			ANT 2		
				165300	167300	169300	165300	167300	169300
5.0	BPSK	1	0	25.19	25.28	25.49	24.98	25.09	24.92
		1	1	25.09	25.34	25.53	25.05	25.16	25.08
		1	23	25.13	25.45	25.64	25.08	25.08	24.78
		1	24	25.25	25.43	25.57	25.06	25.03	24.74
		12	6	25.06	25.31	25.64	24.99	25.15	24.95
		25	0	24.98	25.27	25.55	24.83	25.04	24.79
	QPSK	1	0	24.69	24.85	25.17	24.42	24.63	24.42
		1	1	25.19	25.29	25.61	24.94	25.20	25.11
		1	23	25.16	25.43	25.70	24.94	25.13	24.78
		1	24	24.77	25.01	25.28	24.51	24.50	24.25
		12	6	25.04	25.27	25.64	25.02	25.18	24.92
		25	0	24.61	24.51	25.17	24.36	24.56	24.26
	16QAM	1	0	23.77	23.78	24.30	23.52	23.53	23.64
		1	1	24.71	25.02	25.19	24.19	24.65	24.53
		1	23	24.82	24.83	25.35	24.60	24.36	24.15
		1	24	24.06	24.16	24.20	23.45	23.63	23.40
		12	6	24.68	24.42	25.13	24.36	24.60	24.28
		25	0	23.60	23.48	24.15	23.46	23.52	23.35
	64QAM	1	0	22.93	23.36	23.59	22.65	22.97	22.97
		1	1	23.17	23.35	23.64	22.77	22.99	22.65
		1	23	23.24	23.41	23.63	22.99	22.96	22.42
		1	24	23.17	23.59	23.70	23.03	22.93	22.75
		12	6	23.12	23.00	23.74	22.87	23.12	22.80
		25	0	23.12	22.92	23.64	23.08	23.03	22.81
	256QAM	1	0	21.18	21.19	21.37	20.83	20.84	20.53
		1	1	21.06	21.07	21.36	20.69	20.48	20.74
		1	23	21.17	21.21	21.42	20.74	20.69	20.52
		1	24	20.86	21.28	21.45	20.89	20.87	20.48
		12	6	21.09	21.40	21.83	20.88	21.05	20.80
		25	0	21.30	21.51	21.77	20.91	21.14	20.85

OUTPUT POWER FOR 5G NR n26 (10.0 MHz)

Bandwidth (MHz)	Modulation	RB Allocation	RB Offset	Conducted Average (dBm)					
				ANT 1			ANT 2		
				165800	167300	168800	165800	167300	168800
10.0	BPSK	1	0	25.04	25.24	25.46	24.91	25.09	25.10
		1	1	25.15	25.26	25.46	24.99	25.20	25.16
		1	50	25.31	25.57	25.70	25.03	25.17	24.76
		1	51	25.27	25.43	25.54	25.00	24.97	24.67
		25	12	25.04	25.35	25.47	24.97	25.08	24.92
		50	0	25.18	25.34	25.52	24.95	25.01	24.88
	QPSK	1	0	24.64	24.66	24.97	24.25	24.41	24.43
		1	1	25.15	25.22	25.45	24.98	25.18	25.07
		1	50	25.27	25.47	25.61	25.02	25.17	24.85
		1	51	24.78	25.05	25.13	24.49	24.50	24.24
		25	12	25.09	25.34	25.60	24.98	25.12	24.88
		50	0	24.72	24.96	25.19	24.50	24.53	24.39
	16QAM	1	0	23.49	23.76	24.16	23.57	23.51	23.03
		1	1	24.59	24.73	25.12	24.42	24.45	24.38
		1	50	25.09	25.52	25.20	24.48	24.50	24.11
		1	51	23.75	24.16	24.13	23.35	23.28	23.12
		25	12	24.71	24.38	25.09	24.44	24.44	24.38
		50	0	23.74	23.93	24.11	23.46	23.54	23.39
	64QAM	1	0	22.98	23.35	23.36	22.74	23.14	22.98
		1	1	23.03	23.13	23.25	22.80	23.06	23.02
		1	50	23.32	23.68	23.81	23.21	22.80	22.87
		1	51	23.27	23.48	23.60	22.88	22.76	22.57
		25	12	23.22	22.95	23.59	22.88	22.98	22.86
		50	0	23.25	23.42	23.70	23.01	22.99	22.87
	256QAM	1	0	21.11	21.06	21.30	20.51	20.79	20.97
		1	1	20.98	20.89	21.41	20.58	20.83	20.84
		1	50	20.91	21.25	21.00	20.83	20.70	20.61
		1	51	20.98	21.44	21.46	20.65	20.91	20.40
		25	12	21.22	21.45	21.63	20.97	21.00	20.94
		50	0	21.25	21.46	21.63	21.00	21.01	20.89

OUTPUT POWER FOR 5G NR n26 (15.0 MHz)

Bandwidth (MHz)	Modulation	RB Allocation	RB Offset	Conducted Average (dBm)					
				ANT 1			ANT 2		
				163300	167300	168300	163300	167300	168300
15.0	BPSK	1	0	831.5	836.5	841.5	831.5	836.5	841.5
		1	1	23.53	25.15	25.12	23.63	24.89	24.97
		1	77	24.20	25.02	25.20	24.40	25.02	25.17
		1	78	25.17	25.50	25.64	25.02	25.07	24.88
		36	18	25.12	25.58	25.70	24.89	25.03	24.78
		75	0	25.08	25.05	25.25	24.62	25.01	24.88
	QPSK	1	0	22.06	24.80	24.63	22.01	24.45	24.61
		1	1	23.10	25.05	25.12	23.32	25.05	25.20
		1	77	25.15	25.62	25.61	25.05	25.14	24.88
		1	78	24.72	25.21	25.04	24.31	24.46	24.18
		36	18	25.19	25.10	25.35	24.68	25.09	24.97
		75	0	24.13	24.76	25.03	24.22	24.52	24.44
	16QAM	1	0	21.37	23.80	23.67	20.77	23.59	23.26
		1	1	22.26	24.56	24.66	21.98	24.33	24.75
		1	77	24.57	25.37	24.85	24.66	24.28	24.29
		1	78	23.89	24.28	24.07	23.56	23.69	23.35
		36	18	24.71	24.36	25.04	24.11	24.44	24.38
		75	0	23.39	23.78	24.06	23.02	23.46	23.36
	64QAM	1	0	20.63	23.02	23.27	20.67	23.04	22.98
		1	1	20.38	23.26	23.34	20.79	22.89	23.09
		1	77	23.30	23.38	23.54	22.76	23.00	22.53
		1	78	23.22	23.49	23.55	22.84	23.18	22.71
		36	18	23.27	22.91	23.41	22.61	22.97	22.94
		75	0	22.91	23.27	23.54	22.49	23.01	22.84
	256QAM	1	0	19.21	21.13	20.74	19.11	20.79	20.71
		1	1	19.23	21.03	20.94	19.25	20.63	21.14
		1	77	21.15	21.55	21.29	20.63	20.94	20.36
		1	78	20.64	21.30	21.48	20.59	20.86	20.66
		36	18	21.31	21.28	21.42	20.59	20.98	20.95
		75	0	21.33	21.34	21.46	20.77	21.00	20.97

OUTPUT POWER FOR 5G NR n26 (20.0 MHz)

Bandwidth (MHz)	Modulation	RB Allocation	RB Offset	Conducted Average (dBm)					
				ANT 1			ANT 2		
				162800	167300	167800	162800	167300	167800
20.0	BPSK	1	0	834.0	836.5	839.0	834.0	836.5	839.0
		1	1	25.08	25.17	25.23	25.10	25.09	25.06
		1	104	25.14	25.07	25.22	25.16	25.11	25.17
		1	105	25.57	25.60	25.70	25.14	25.13	24.92
		50	25	25.62	25.61	25.55	25.04	24.98	24.84
		100	0	25.21	25.26	25.44	25.11	25.17	25.17
	QPSK	1	0	25.24	25.32	25.44	25.00	25.13	25.07
		1	1	24.72	24.66	24.70	24.35	24.58	24.59
		1	104	25.02	25.17	25.18	25.07	25.16	25.19
		1	105	25.54	25.65	25.70	25.19	25.06	24.88
		50	25	25.17	25.16	25.31	24.64	24.47	24.28
		100	0	25.20	25.35	25.46	25.12	25.15	25.20
	16QAM	1	0	24.83	24.89	25.07	24.50	24.59	24.57
		1	1	23.46	23.77	23.60	23.64	23.33	23.49
		1	104	24.63	24.45	24.66	24.77	24.52	24.23
		1	105	25.19	25.29	25.02	24.43	24.64	24.29
		50	25	24.30	24.06	24.09	23.60	23.45	23.34
		100	0	24.82	25.02	25.02	24.47	24.58	24.61
	64QAM	1	0	23.84	23.91	24.00	23.48	23.54	23.55
		1	1	23.38	23.25	23.28	22.70	22.94	22.99
		1	104	23.23	23.26	23.16	22.88	23.04	22.85
		1	105	23.74	23.80	23.60	22.84	22.90	22.73
		50	25	23.52	23.71	23.55	23.00	23.09	22.71
		100	0	23.37	23.41	23.50	22.96	23.04	23.04
	256QAM	1	0	23.30	23.38	23.55	23.00	23.11	23.10
		1	1	21.23	21.37	21.18	20.85	20.70	20.75
		1	104	21.30	21.29	21.12	20.92	20.87	20.82
		1	105	21.75	21.65	21.60	20.75	20.76	20.68
		50	25	21.52	21.72	21.86	20.85	20.90	20.85
		100	0	21.21	21.42	21.45	21.05	21.12	21.07

8.9. LTE BAND 30 AND 5G NR n30

LTE BAND 30

Test Engineer ID:	32061	Test Date:	2024-02-27
-------------------	-------	------------	------------

OUTPUT POWER FOR LTE BAND 30 (5.0 MHz)

Bandwidth (MHz)	Modulation	RB Allocation	RB Offset	Conducted Average (dBm)											
				ANT 1			ANT 2			ANT 3			ANT 4		
				27685	27710	27735	27685	27710	27735	27685	27710	27735	27685	27710	27735
5.0	QPSK	1	0	25.64	25.57	25.57	22.52	22.46	22.47	22.82	22.96	23.09	22.65	22.53	22.52
		1	12	25.65	25.62	25.70	22.58	22.59	22.60	23.03	23.20	23.20	22.70	22.56	22.57
		1	24	25.57	25.57	25.57	22.45	22.42	22.40	23.06	23.07	23.05	22.53	22.51	22.45
		12	0	25.26	25.21	25.12	21.49	21.49	21.50	21.90	22.03	22.10	21.59	21.52	21.51
		12	6	25.28	25.23	25.17	21.46	21.43	21.56	22.04	22.06	22.13	21.59	21.59	21.51
		12	11	25.16	25.21	25.20	21.42	21.43	21.50	22.03	22.04	22.10	21.53	21.53	21.51
	16QAM	25	0	25.27	25.20	25.14	21.42	21.39	21.47	22.00	22.01	22.09	21.60	21.53	21.50
		1	0	25.39	25.46	25.37	21.69	21.67	21.72	22.02	22.16	22.29	21.77	21.72	21.66
		1	12	25.49	25.45	25.49	21.76	21.75	21.76	22.15	22.36	22.41	21.86	21.85	21.73
		1	24	25.33	25.38	25.35	21.72	21.66	21.64	22.15	22.26	22.25	21.67	21.66	21.71
		12	0	24.33	24.17	24.12	20.46	20.53	20.39	20.88	21.09	21.13	20.61	20.60	20.56
		12	6	24.36	24.21	24.19	20.43	20.47	20.42	21.01	21.14	21.15	20.63	20.67	20.61
	64QAM	12	11	24.25	24.16	24.19	20.41	20.43	20.42	20.99	21.10	21.11	20.51	20.59	20.57
		25	0	24.24	24.20	24.15	20.45	20.42	20.50	20.99	21.03	21.12	20.60	20.54	20.51
		1	0	24.49	24.53	24.47	20.78	20.82	20.78	21.13	21.27	21.40	20.97	20.83	20.79
		1	12	24.56	24.50	24.50	20.85	20.83	20.81	21.28	21.40	21.44	20.95	20.86	20.78
		1	24	24.41	24.41	24.47	20.70	20.69	20.69	21.34	21.35	21.30	20.88	20.72	20.83
		12	0	23.25	23.29	23.19	19.43	19.49	19.52	19.97	20.08	20.13	19.59	19.52	19.52
	256QAM	12	6	23.27	23.33	23.24	19.39	19.43	19.56	20.11	20.15	20.16	19.62	19.56	19.57
		12	11	23.16	23.27	23.29	19.38	19.41	19.51	20.07	20.12	20.15	19.50	19.49	19.54
		25	0	23.23	23.22	23.16	19.44	19.42	19.51	20.02	20.04	20.13	19.61	19.55	19.51
		1	0	21.36	21.31	21.21	17.65	17.60	17.57	17.96	18.07	18.24	17.77	17.68	17.62
		1	12	21.43	21.36	21.34	17.70	17.69	17.68	18.13	18.34	18.29	17.81	17.74	17.71
		1	24	21.29	21.28	21.31	17.57	17.53	17.51	18.21	18.24	18.17	17.64	17.59	17.62

OUTPUT POWER FOR LTE BAND 30 (10.0 MHz)

Bandwidth (MHz)	Modulation	RB Allocation	RB Offset	Conducted Average (dBm)											
				ANT 1			ANT 2			ANT 3			ANT 4		
				N/A	27710	N/A	N/A	27710	N/A	N/A	27710	N/A	N/A	27710	N/A
10.0	QPSK	1	0		25.70			22.60			22.98		22.70		
		1	24		25.69			22.54			23.20		22.68		
		1	49		25.67			22.45			23.15		22.57		
		25	0		25.33			21.57			22.00		21.68		
		25	12		25.32			21.51			22.12		21.70		
		25	24		25.28			21.47			22.16		21.57		
	16QAM	50	0		25.30			21.46			22.07		21.66		
		1	0		25.46			21.79			22.20		21.91		
		1	24		25.46			21.72			22.34		21.85		
		1	49		25.48			21.61			22.24		21.71		
		25	0		24.29			20.57			21.02		20.70		
		25	12		24.31			20.50			21.12		20.70		
	64QAM	25	24		24.28			20.48			21.20		20.58		
		50	0		24.30			20.49			21.06		20.68		
		1	0		24.61			20.85			21.25		21.00		
		1	24		24.56			20.82			21.46		20.95		
		1	49		24.55			20.77			21.36		20.88		
		25	0		23.30			19.58			20.02		19.69		
	256QAM	25	12		23.31			19.53			20.11		19.69		
		25	24		23.28			19.49			20.18		19.58		
		50	0		23.27			19.46			20.10		19.70		
		1	0		21.43			17.65			17.97		17.80		
		1	24		21.43			17.68			18.29		17.83		
		1	49		21.37			17.56			18.17		17.67		

5G NR n30

Test Engineer ID:	32061	Test Date:	2024-02-27
-------------------	-------	------------	------------

OUTPUT POWER FOR 5G NR n30 (5.0 MHz)

Bandwidth (MHz)	Modulation	RB Allocation	RB Offset	Conducted Average (dBm)											
				ANT 1			ANT 2			ANT 3			ANT 4		
				461500	462000	462500	461500	462000	462500	461500	462000	462500	461500	462000	462500
5.0	BPSK	1	0	20.70	20.68	20.70	18.68	18.68	18.70	19.92	19.96	20.00	17.61	17.70	17.69
		1	1	20.61	20.66	20.70	18.70	18.61	18.62	19.92	19.92	20.00	17.63	17.70	17.62
		1	23	20.63	20.59	20.70	18.63	18.70	18.63	19.99	19.98	20.00	17.60	17.66	17.70
		1	24	20.70	20.35	20.31	18.70	18.70	18.68	19.89	20.00	19.75	17.46	17.58	17.70
		12	6	20.57	20.66	20.70	18.70	18.70	18.59	20.00	20.00	19.85	17.65	17.69	17.70
		25	0	25.20	25.20	25.20	22.60	22.60	22.60	23.20	23.20	23.20	22.20	22.20	22.20
	QPSK	1	0	20.70	20.59	20.34	18.68	18.70	18.63	19.88	19.78	20.00	17.70	17.61	17.62
		1	1	20.70	20.64	20.29	18.66	18.70	18.69	19.91	19.76	20.00	17.70	17.57	17.47
		1	23	20.70	20.57	20.40	18.70	18.66	18.31	19.90	20.00	19.98	17.70	17.70	17.66
		1	24	20.70	20.47	20.33	18.70	18.57	18.54	19.97	19.95	20.00	17.53	17.70	17.60
		12	6	20.59	20.56	20.70	18.70	18.60	18.62	19.91	19.77	20.00	17.70	17.64	17.68
		25	0	24.74	24.80	24.71	22.55	22.53	22.60	22.93	23.03	23.20	21.88	21.85	21.87
	16QAM	1	0	20.70	20.37	20.62	18.57	18.70	18.54	19.21	19.86	20.00	17.70	17.29	17.13
		1	1	20.36	20.70	20.12	18.52	18.58	18.70	19.97	19.78	20.00	17.70	17.66	17.36
		1	23	20.70	20.09	20.25	18.70	18.48	18.44	19.97	19.66	20.00	17.60	17.70	17.52
		1	24	20.70	20.15	20.22	18.60	18.70	18.41	19.76	19.78	20.00	17.70	17.55	17.59
		12	6	20.58	20.67	20.70	18.70	18.61	18.43	19.89	19.93	20.00	17.56	17.49	17.70
		25	0	23.79	23.84	23.73	21.68	21.56	21.80	23.04	23.17	23.20	20.80	20.86	20.88
	64QAM	1	0	20.54	20.70	20.64	18.61	18.59	18.32	19.76	19.52	19.82	17.37	17.20	17.13
		1	1	20.09	19.96	19.69	18.57	18.48	18.66	19.66	19.75	19.82	17.30	16.93	17.33
		1	23	20.38	20.70	20.23	18.70	18.56	18.43	19.67	19.79	19.87	17.22	17.18	17.27
		1	24	20.60	20.49	20.51	18.57	18.45	18.33	19.69	20.00	19.58	17.40	17.43	17.31
		12	6	20.69	20.65	20.70	18.25	18.24	18.26	19.39	19.48	19.59	17.64	17.58	17.70
		25	0	23.37	23.31	23.24	21.17	21.05	21.23	22.57	22.76	22.80	20.31	20.26	20.32
	256QAM	1	0	20.37	20.47	20.26	18.54	18.44	18.55	19.90	19.96	19.81	17.68	17.37	17.63
		1	1	20.40	20.61	20.45	18.55	18.45	18.46	19.67	19.69	19.96	17.35	17.33	17.41
		1	23	20.48	20.44	20.20	18.56	18.48	18.55	19.90	20.00	19.82	17.56	17.50	17.29
		1	24	20.63	20.44	20.44	18.53	18.40	18.61	19.99	19.97	19.89	17.57	17.46	17.44
		12	6	20.59	20.70	20.67	18.70	18.64	18.61	19.92	19.89	19.78	17.65	17.70	17.69
		25	0	21.29	21.28	21.16	19.15	19.12	19.18	20.62	20.72	20.75	18.33	18.34	18.32

OUTPUT POWER FOR 5G NR n30 (10.0 MHz)

Bandwidth (MHz)	Modulation	RB Allocation	RB Offset	Conducted Average (dBm)											
				ANT 1			ANT 2			ANT 3			ANT 4		
				N/A	462000	N/A	N/A	462000	N/A	N/A	462000	N/A	N/A	462000	N/A
10.0	BPSK	1	0	20.70			18.25			19.86			17.68		
		1	1	20.65			18.68			19.81			17.62		
		1	50	20.66			18.70			20.00			17.70		
		1	51	20.30			18.23			19.92			17.63		
		25	12	20.61			18.63			19.91			17.55		
		50	0	25.20			22.60			23.20			22.20		
	QPSK	1	0	19.13			17.67			19.33			17.24		
		1	1	20.14			18.57			19.93			17.59		
		1	50	19.75			18.33			20.00			17.70		
		1	51	18.89			17.53			19.44			17.19		
		25	12	20.70			18.70			19.91			17.54		
		50	0	24.76			22.57			23.18			21.80		
	16QAM	1	0	19.48			17.57			18.51			16.53		
		1	1	20.70			18.70			20.00			17.25		
		1	50	20.36			18.48			19.43			17.70		
		1	51	19.18			17.59			19.00			16.16		
		25	12	20.70			18.70			20.00			17.70		
		50	0	23.77			21.70			23.15			20.79		
	64QAM	1	0	19.58			18.46			19.73			17.53		
		1	1	19.48			18.62			19.49			17.46		
		1	50	19.24			18.62			20.00			17.27		
		1	51	19.55			18.70			19.69			17.11		
		25	12	20.70			18.26			19.55			17.70		
		50	0	23.29			21.14			22.97			20.28		
	256QAM	1	0	20.70			18.22			19.71			17.36		
		1	1	20.61			18.34			19.62			17.55		
		1	50	20.57			18.70			19.82			17.54		
		1	51	20.70			18.40			19.82			17.42		
		25	12	20.69			18.51			20.00			17.70		
		50	0	21.07			19.21			21.02			22.20		

8.10. LTE BAND 41 AND 5G NR n41

LTE BAND 41

Test Engineer ID:	28774	Test Date:	2024-02-16
-------------------	-------	------------	------------

OUTPUT POWER FOR LTE BAND 41 (5.0 MHz)

Bandwidth (MHz)	Modulation	RB Allocation	RB Offset	Conducted Average (dBm)											
				ANT 1			ANT 2			ANT 3			ANT 4		
				39675	40620	41565	39675	40620	41565	39675	40620	41565	39675	40620	41565
5.0	QPSK	1	0	25.34	28.31	27.56	25.77	28.54	27.66	22.70	27.73	26.93	23.28	27.69	26.26
		1	12	27.70	28.43	27.70	27.80	28.70	27.80	26.08	27.76	27.00	26.29	27.70	26.30
		1	24	27.62	28.38	27.67	27.76	28.50	27.72	26.20	27.74	26.91	26.30	27.60	26.24
		12	0	24.43	28.35	27.39	24.75	28.58	27.84	21.91	27.76	26.07	22.33	27.53	25.46
		12	6	24.43	28.45	27.40	24.83	28.55	27.76	22.08	27.78	26.11	22.37	27.50	25.55
		12	11	27.39	28.47	27.40	27.81	28.49	27.83	25.16	27.73	26.04	25.43	27.43	25.49
		25	0	24.38	28.39	27.37	24.76	28.52	27.77	22.03	27.75	26.08	22.37	27.39	25.48
		25	0	24.44	28.52	27.51	24.88	28.58	27.89	21.93	27.93	26.10	22.39	27.54	25.55
	16QAM	1	12	27.56	28.70	27.49	28.00	28.62	28.00	25.20	28.00	26.23	25.53	27.59	25.65
		1	24	27.48	28.60	27.49	27.88	28.59	27.91	25.43	27.90	26.11	25.54	27.50	25.48
		12	0	23.45	28.15	26.38	23.89	28.26	26.78	21.01	26.73	25.12	21.23	26.50	24.57
		12	6	23.42	28.17	26.44	23.71	28.32	26.93	21.07	26.88	25.19	21.41	26.65	24.58
		12	11	26.50	28.19	26.46	26.82	28.27	26.92	24.12	26.85	25.00	24.34	26.47	24.65
		25	0	23.41	28.15	26.44	23.82	28.22	26.84	21.07	26.80	25.08	21.33	26.52	24.59
		1	0	23.72	28.30	26.62	24.05	28.54	27.03	21.08	27.07	25.30	21.53	26.79	24.77
		1	12	26.69	28.41	26.80	27.19	28.64	27.18	24.41	27.14	25.32	24.59	26.77	24.78
	64QAM	1	24	26.55	28.41	26.59	27.10	28.53	27.12	24.49	27.04	25.20	24.62	26.72	24.75
		12	0	22.47	27.17	25.44	22.78	27.40	25.83	20.05	25.81	24.18	20.37	25.70	23.65
		12	6	22.54	27.21	25.41	22.91	27.32	25.89	20.03	25.86	24.29	20.45	25.64	23.62
		12	11	25.41	27.26	25.44	25.91	27.19	25.93	23.30	25.67	23.99	23.31	25.52	23.70
		25	0	22.42	27.17	25.43	22.79	27.21	25.83	20.09	25.81	24.14	20.36	25.48	23.62
		1	0	20.56	25.31	23.56	20.92	25.34	23.98	17.98	23.95	22.14	18.37	23.63	21.68
		1	12	23.68	25.39	23.55	24.00	25.43	23.93	21.34	24.12	22.26	21.51	23.75	21.77
		1	24	23.54	25.25	23.52	24.00	25.20	23.90	21.45	23.86	22.20	21.59	23.58	21.57
	256QAM	12	0	20.44	25.11	23.41	20.82	25.24	23.85	17.91	23.80	22.11	18.35	23.63	21.55
		12	6	20.48	25.17	23.48	20.86	25.27	23.92	18.13	23.87	22.10	18.38	23.65	21.65
		12	11	23.46	25.22	23.46	23.81	25.25	23.86	21.18	23.81	22.03	21.43	23.51	21.65
		25	0	20.41	25.11	23.41	20.81	25.20	23.84	18.05	23.80	22.09	18.33	23.50	21.63

OUTPUT POWER FOR LTE BAND 41 (10.0 MHz)

Bandwidth (MHz)	Modulation	RB Allocation	RB Offset	Conducted Average (dBm)											
				ANT 1			ANT 2			ANT 3			ANT 4		
				39700	40620	41540	39700	40620	41540	39700	40620	41540	39700	40620	41540
10.0	QPSK	1	0	23.34	28.35	27.62	23.80	28.50	27.78	20.56	27.78	26.94	21.20	27.68	26.23
		1	24	27.70	28.67	27.69	27.88	28.59	27.89	26.06	27.87	27.00	26.30	27.70	26.30
		1	49	27.70	28.65	27.70	27.76	28.55	27.80	26.20	27.84	26.99	26.22	27.55	26.18
		25	0	24.50	28.41	27.45	24.88	28.70	27.94	21.94	27.87	26.10	22.34	27.53	25.50
		25	12	27.54	28.70	27.48	27.84	28.58	27.93	25.13	27.88	26.12	25.37	27.44	25.51
		25	24	26.51	28.69	27.47	26.82	28.60	27.96	24.25	27.87	26.05	24.35	27.42	25.47
		50	0	24.48	28.42	27.48	24.80	28.55	27.93	22.09	27.88	26.10	22.29	27.43	25.48
		1	0	22.47	28.51	27.40	22.86	28.56	27.88	19.73	27.85	26.03	20.29	27.48	25.52
	16QAM	1	24	27.49	28.58	27.54	28.00	28.70	28.00	25.19	28.00	26.16	25.42	27.52	25.47
		1	49	27.44	28.48	27.52	27.87	28.59	27.95	25.35	27.93	26.16	25.38	27.39	25.37
		25	0	23.54	28.12	26.48	23.90	28.28	26.90	20.97	26.88	25.12	21.37	26.58	24.56
		25	12	26.54	28.15	26.51	26.86	28.28	26.95	24.18	26.94	25.15	24.39	26.50	24.58
		25	24	25.51	28.21	26.54	25.80	28.23	26.96	23.28	26.90	25.08	23.36	26.50	24.56
		50	0	23.49	28.12	26.50	23.81	28.21	26.91	21.08	26.89	25.12	21.32	26.48	24.53
		1	0	21.62	28.31	26.59	22.00	28.40	27.05	18.86	27.05	25.21	19.36	26.69	24.64
		1	24	26.67	28.47	26.68	27.15	28.53	27.19	24.39	27.18	25.32	24.58	26.73	24.68
	64QAM	1	49	26.62	28.38	26.70	27.05	28.49	27.15	24.54	27.12	25.25	24.64	26.65	24.61
		25	0	22.55	27.14	25.53	22.92	27.29	25.91	19.98	25.90	24.13	20.39	25.63	23.56
		25	12	25.54	27.16	25.55	25.86	27.28	25.97	23.21	25.93	24.18	23.39	25.57	23.61
		25	24	24.54	27.23	25.52	24.82	27.27	26.00	22.30	25.91	24.07	22.37	25.50	23.59
		50	0	22.51	27.13	25.54	22.83	27.27	25.95	20.11	25.93	24.11	20.30	25.53	23.55
		1	0	18.55	25.23	23.53	18.94	25.25	23.87	15.77	23.88	22.12	16.33	23.59	21.59
		1	24	23.62	25.39	23.62	24.06	25.42	24.10	21.29	24.12	22.19	21.56	23.78	21.73
		1	49	23.61	25.19	23.60	23.95	25.34	23.91	21.44	24.03	22.15	21.44	23.60	21.53
	256QAM	25	0	20.53	25.16	23.47	20.91	25.32	23.98	17.97	23.93	22.08	18.34	23.64	21.59
		25	12	23.58	25.20	23.54	23.88	25.30	24.01	21.18	24.00	22.11	21.37	23.59	21.62
		25	24	22.53	25.24	23.51	22.88	25.28	23.98	20.31	23.94	22.04	20.38	23.57	21.61
		50	0	20.51	25.16	23.46	20.87	25.23	23.96	18.12	23.94	22.12	18.25	23.56	21.61

OUTPUT POWER FOR LTE BAND 41 (15.0 MHz)

Bandwidth (MHz)	Modulation	RB Allocation	RB Offset	Conducted Average (dBm)											
				ANT 1			ANT 2			ANT 3			ANT 4		
				39725	40620	41515	39725	40620	41515	39725	40620	41515	39725	40620	41515
15.0	QPSK	1	0	22.70	28.63	27.51	23.01	28.42	27.74	20.50	27.82	26.98	21.10	27.70	26.30
		1	37	27.70	28.61	27.56	27.88	28.49	27.83	26.06	27.81	26.98	26.30	27.64	26.17
		1	74	27.61	28.61	27.70	27.85	28.70	27.88	26.20	27.88	27.00	26.18	27.59	26.18
		36	0	22.63	28.64	27.31	23.06	28.57	27.88	20.83	27.80	26.02	21.26	27.52	25.49
		36	16	27.50	28.62	27.30	27.83	28.52	27.88	25.13	27.83	26.05	25.36	27.41	25.47
		36	35	23.70	28.70	27.33	24.00	28.54	27.85	22.18	27.86	25.99	22.30	27.37	25.43
	16QAM	75	0	22.73	28.62	27.32	23.02	28.53	27.90	21.05	27.82	26.02	21.28	27.39	25.47
		1	0	21.70	28.33	27.33	22.11	28.65	27.79	19.56	27.85	26.09	20.20	27.46	25.41
		1	37	27.61	28.35	27.34	28.00	28.65	27.89	25.28	28.00	26.08	25.40	27.44	25.42
		1	74	27.46	28.34	27.35	27.93	28.61	28.00	25.25	27.96	26.20	25.39	27.39	25.44
		36	0	21.65	27.92	26.23	22.06	28.30	26.89	19.82	26.83	25.04	20.25	26.56	24.55
		36	16	26.54	27.92	26.24	26.86	28.26	26.91	24.11	26.85	25.06	24.37	26.47	24.54
	64QAM	36	35	22.72	28.01	26.27	23.00	28.28	26.86	21.19	26.87	25.00	21.31	26.44	24.53
		75	0	21.75	27.95	26.28	22.02	28.27	26.90	20.08	26.85	25.05	20.29	26.48	24.54
		1	0	20.87	28.17	26.34	21.31	28.39	27.07	18.79	27.03	25.24	19.33	26.68	24.88
		1	37	26.66	28.12	26.49	27.11	28.41	27.04	24.30	27.05	25.21	24.62	26.64	24.64
		1	74	26.73	28.25	26.43	27.12	28.50	27.23	24.38	27.10	25.31	24.54	26.58	24.74
		36	0	20.69	26.93	25.25	21.08	27.31	25.90	18.86	25.81	24.04	19.25	25.57	23.57
	256QAM	36	16	25.55	26.94	25.25	25.90	27.25	25.91	23.15	25.85	24.07	23.35	25.46	23.56
		36	35	21.73	26.99	25.25	22.04	27.28	25.87	20.20	25.86	24.02	20.31	25.45	23.53
		75	0	20.76	26.93	25.26	21.03	27.29	25.97	19.12	25.85	24.08	19.31	25.47	23.55
		1	0	17.86	24.99	23.31	18.24	25.38	24.04	15.55	23.86	22.12	16.16	23.69	21.61
		1	37	23.68	25.00	23.38	24.09	25.39	23.96	21.23	24.03	22.04	21.42	23.63	21.62
		1	74	23.70	25.04	23.28	23.99	25.37	24.04	21.34	24.03	22.23	21.63	23.67	21.61
	256QAM	36	0	18.69	24.91	23.26	19.09	25.31	23.93	16.88	23.85	22.05	17.25	23.55	21.57
		36	16	23.56	24.91	23.26	23.88	25.26	23.92	21.13	23.88	22.09	21.38	23.49	21.58
		36	35	19.74	25.01	23.27	20.05	25.30	23.88	18.21	23.92	22.02	18.30	23.47	21.51
		75	0	18.76	24.92	23.28	19.02	25.26	23.92	17.12	23.90	22.08	17.26	23.48	21.57

OUTPUT POWER FOR LTE BAND 41 (20.0 MHz)

Bandwidth (MHz)	Modulation	RB Allocation	RB Offset	Conducted Average (dBm)											
				ANT 1			ANT 2			ANT 3			ANT 4		
				39750	40620	41490	39750	40620	41490	39750	40620	41490	39750	40620	41490
20.0	QPSK	1	0	22.70	28.58	27.54	22.98	28.50	27.84	20.51	27.78	26.89	21.17	27.70	26.30
		1	49	27.70	28.60	27.55	27.86	28.52	27.87	26.11	27.81	26.87	26.30	27.56	26.17
		1	99	27.61	28.63	27.70	27.85	28.70	27.97	26.20	27.86	27.00	26.23	27.49	26.14
		50	0	22.66	28.63	27.29	23.04	28.56	27.94	20.88	27.75	25.92	21.33	27.44	25.43
		50	24	27.47	28.61	27.35	27.98	28.55	27.98	25.16	27.80	25.99	25.45	27.35	25.43
		50	49	23.70	28.70	27.34	24.00	28.57	27.95	22.20	27.81	25.94	22.30	27.28	25.37
	16QAM	100	0	22.73	28.63	27.34	23.07	28.54	27.99	21.08	27.79	25.95	21.34	27.32	25.42
		1	0	21.73	27.93	27.19	21.89	28.48	27.94	19.52	27.79	25.82	20.24	27.58	25.45
		1	49	27.56	28.04	27.43	28.00	28.66	27.88	25.39	28.00	26.18	25.46	27.36	25.38
		1	99	27.40	27.96	27.32	27.98	28.70	28.00	25.49	27.83	25.99	25.27	27.23	25.41
		50	0	21.68	27.60	26.30	22.03	28.30	26.95	19.89	26.76	24.91	20.35	26.51	24.48
		50	24	26.49	27.61	26.32	27.02	28.30	27.03	24.17	26.81	25.00	24.44	26.41	24.51
	64QAM	50	49	22.71	27.71	26.38	23.03	28.30	27.00	21.21	26.84	24.94	21.26	26.36	24.44
		100	0	21.70	27.64	26.35	22.02	28.32	27.01	20.08	26.83	24.94	20.37	26.40	24.48
		1	0	20.75	27.82	26.42	21.27	28.47	27.17	18.65	27.08	25.08	19.36	26.63	24.64
		1	49	26.77	27.86	26.47	27.17	28.46	27.03	24.41	27.07	25.19	24.61	26.50	24.58
		1	99	26.41	27.81	26.69	26.97	28.58	27.23	24.36	27.11	25.16	24.39	26.37	24.76
		50	0	20.67	26.63	25.33	21.04	27.31	25.96	18.91	25.77	23.92	19.32	25.46	23.48
	256QAM	50	24	25.45	26.66	25.35	25.97	27.28	26.02	23.18	25.81	23.96	23.44	25.43	23.50
		50	49	21.67	26.67	25.38	21.99	27.30	25.97	20.19	25.83	23.93	20.27	25.38	23.44
		100	0	20.74	26.60	25.38	21.07	27.30	26.05	19.12	25.88	23.97	19.33	25.41	23.49
		1	0	17.68	24.67	23.31	18.17	25.34	24.13	15.69	23.89	22.18	16.33	23.61	21.60
		1	49	23.52	24.92	23.54	24.10	25.42	24.11	21.20	23.95	22.09	21.53	23.58	21.62
		1	99	23.59	24.77	23.61	23.90	25.49	24.20	21.42	24.06	22.01	21.51	23.60	21.39
	256QAM	50	0	18.67	24.61	23.36	19.06	25.33	23.98	16.93	23.83	21.94	17.32	23.48	21.46
		50	24	23.49	24.64	23.38	23.96	25.27	24.03	21.16	23.85	22.00	21.42	23.42	21.50
		50	49	19.71	24.66	23.40	20.02	25.31	23.94	18.22	23.85	21.90	18.28	23.36	21.40
		100	0	18.75	24.61	23.37	19.07	25.27	24.00	17.15	23.84	21.97	17.27	23.40	21.48

5G NR n41

Test Engineer ID:	25780	Test Date:	2/23/2024
-------------------	-------	------------	-----------

OUTPUT POWER FOR 5G NR n41 (10.0 MHz)

Bandwidth (MHz)	Modulation	RB Allocation	RB Offset	Conducted Average (dBm)											
				ANT 2			ANT 1			ANT 4			ANT 3		
				500200	518600	537000	500200	518600	537000	500200	518600	537000	500200	518600	537000
10.0	BPSK	1	0	22.47	25.20	24.22	22.07	25.15	24.09	20.80	23.88	22.80	20.22	24.27	23.37
		1	1	22.50	28.05	27.94	22.20	28.63	27.70	20.73	27.55	26.30	20.33	27.83	26.86
		1	22	27.97	28.70	28.00	27.70	28.66	27.43	26.29	27.70	26.22	26.14	27.50	26.85
		1	23	25.41	26.16	25.23	24.51	25.98	24.64	23.76	24.71	23.37	22.79	25.50	25.16
		12	6	24.36	28.46	27.93	24.20	28.68	26.92	22.80	27.58	26.09	22.64	27.99	26.85
		24	0	24.50	28.44	27.93	24.19	28.70	26.92	22.73	27.67	25.71	22.62	28.00	26.89
		1	0	21.92	25.03	24.23	21.83	25.20	24.20	20.27	23.69	22.26	19.80	24.50	23.50
		1	1	21.96	28.25	27.37	21.84	28.52	27.03	20.28	27.61	25.59	19.81	27.25	26.84
	1	22	28.00	28.51	27.77	27.15	28.15	26.68	26.30	27.40	25.61	26.20	27.01	27.00	
	1	23	25.38	26.08	25.10	24.58	26.11	24.55	23.71	24.62	23.22	22.85	25.40	25.15	
	12	6	23.47	28.38	27.71	23.19	28.24	26.33	21.70	27.64	25.51	21.63	27.98	26.84	
	24	0	23.47	28.23	27.06	23.28	27.62	25.65	21.68	27.04	24.83	21.62	27.46	26.92	
	1	0	21.85	25.15	24.50	21.76	25.05	24.18	20.13	24.20	22.40	19.85	24.27	23.34	
	1	1	22.12	27.91	26.38	21.96	27.96	26.41	20.16	27.22	24.96	19.81	26.58	26.81	
	1	22	27.44	28.03	27.31	26.10	27.40	25.85	26.23	27.04	24.85	25.18	26.43	27.00	
	1	23	25.52	26.30	25.29	24.66	26.06	24.49	23.56	24.75	23.09	23.20	25.33	25.06	
	12	6	23.05	28.27	27.01	22.67	27.50	25.62	21.17	26.93	24.93	21.19	27.24	26.83	
	24	0	22.91	27.26	26.26	22.69	26.76	24.77	21.34	26.34	24.28	21.19	26.38	26.14	
	1	0	21.39	24.89	23.96	21.20	25.20	24.07	20.01	23.88	22.63	19.08	24.32	23.41	
	1	1	21.35	26.33	25.27	-0.64	26.74	25.28	19.92	25.70	23.97	19.19	25.51	25.97	
	1	22	26.33	26.93	25.98	25.07	26.47	24.88	24.67	25.93	23.99	23.89	25.30	26.12	
	1	23	25.28	25.82	25.05	24.79	26.08	24.32	23.74	24.95	23.72	22.74	25.38	25.13	
	12	6	22.91	26.90	26.11	22.69	26.43	24.39	21.16	25.83	23.85	21.07	26.18	25.67	
	24	0	22.93	26.88	25.94	22.80	26.34	24.43	21.36	25.92	23.90	21.14	26.06	25.70	
	1	0	19.58	23.97	22.75	19.79	23.96	23.12	18.24	23.21	21.62	17.62	23.03	22.56	
	1	1	19.87	24.53	24.46	19.74	25.04	23.76	18.35	24.09	22.60	17.72	24.18	24.23	
	1	22	24.42	24.80	23.70	23.49	25.05	23.58	22.87	24.09	22.73	21.78	24.12	24.30	
	1	23	24.13	24.95	23.68	23.59	25.05	23.61	22.62	24.05	22.94	21.49	24.18	24.08	
	12	6	21.41	24.94	24.32	21.30	25.06	23.24	19.68	24.04	22.60	19.45	24.36	24.00	
	24	0	21.48	24.86	24.25	21.22	25.06	23.20	19.71	24.08	22.68	19.59	24.38	24.16	

OUTPUT POWER FOR 5G NR n41 (15.0 MHz)

Bandwidth (MHz)	Modulation	RB Allocation	RB Offset	Conducted Average (dBm)											
				ANT 2			ANT 1			ANT 4			ANT 3		
				500700	518600	536500	500700	518600	536500	500700	518600	536500	500700	518600	536500
15.0	BPSK	1	0	22.49	25.20	24.35	22.16	25.03	24.09	20.80	24.04	22.80	20.10	24.47	23.40
		1	1	22.50	28.23	27.60	22.20	28.58	27.70	20.74	27.70	26.30	20.21	27.53	26.58
		1	36	28.00	28.70	28.00	27.70	28.70	27.31	26.30	27.63	26.13	26.20	27.40	26.55
		1	37	25.25	26.38	25.38	24.45	26.09	24.82	23.64	24.80	23.31	22.89	25.45	24.96
		18	9	24.50	28.60	27.98	24.07	28.67	27.12	22.79	27.57	26.11	22.64	27.81	26.58
		36	0	24.50	28.60	27.66	24.20	28.66	27.10	22.80	27.56	25.67	22.63	28.00	26.64
		1	0	21.92	25.15	24.50	21.57	25.19	24.15	20.24	23.87	22.29	19.55	24.38	23.50
		1	1	21.91	28.19	26.87	21.63	28.19	27.22	20.27	27.69	25.70	19.61	27.00	26.61
	1	36	27.83	28.24	27.79	26.85	28.05	26.58	26.20	27.11	25.45	26.18	26.88	26.66	
	1	37	25.38	26.37	25.39	24.39	26.15	24.98	23.77	24.79	23.42	22.78	25.36	25.04	
	18	9	23.48	28.56	27.38	23.02	28.12	26.49	21.79	27.31	25.47	21.70	27.91	26.58	
	36	0	23.50	28.25	26.67	23.00	27.27	25.73	21.76	26.72	24.83	21.62	26.73	26.63	
	1	0	22.09	25.08	23.65	21.54	25.20	23.99	20.10	24.20	22.42	19.36	24.50	23.25	
	1	1	22.01	27.90	26.21	21.38	27.57	26.64	20.40	27.02	25.01	19.66	26.39	27.00	
	1	36	27.28	27.65	27.05	25.98	27.45	25.55	25.97	26.74	24.78	25.27	26.10	26.69	
	1	37	25.33	25.89	25.23	24.29	26.04	24.83	23.59	24.88	23.43	22.95	25.37	24.73	
	18	9	22.93	28.38	26.68	22.38	27.41	25.72	21.20	26.80	24.92	21.13	26.89	26.49	
	36	0	23.01	27.55	26.04	22.57	26.56	25.01	21.25	26.19	24.28	21.10	25.93	25.81	
	1	0	21.27	25.01	23.57	21.03	25.12	24.20	19.68	23.97	22.80	18.95	24.29	23.39	
	1	1	21.44	26.78	25.13	-0.64	26.33	25.60	19.72	25.86	24.10	19.17	25.20	25.87	
	1	36	26.34	26.62	26.22	25.01	26.20	24.97	24.69	25.96	23.79	23.84	25.37	25.54	
	1	37	25.37	26.17	25.16	24.48	26.12	24.80	23.79	24.88	23.57	22.66	25.15	24.91	
	18	9	22.92	27.07	25.68	22.66	26.23	24.74	21.21	25.93	23.95	21.09	25.82	25.56	
	36	0	22.93	27.05	25.70	22.70	26.26	24.63	21.22	25.84	23.95	21.08	25.68	25.59	
	1	0	19.59	23.89	22.70	19.60	24.08	22.87	17.92	23.04	21.74	17.26	22.68	22.23	
	1	1	19.33	24.33	23.97	19.59	24.86	23.83	18.29	23.97	22.90	17.62	23.90	23.88	
	1	36	24.27	25.22	24.34	23.40	24.97	23.59	22.50	23.98	22.71	21.51	23.92	23.75	
	1	37	24.10	25.23	24.03	23.32	24.82	23.55	22.74	23.94	22.43	21.49	24.10	23.73	
	18	9	21.31	25.01	24.39	21.06	25.01	23.37	19.69	23.91	22.73	19.63	24.17	23.88	
	36	0	21.50	25.02	24.54	21.04	25.01	23.66	19.65	23.87	22.65	19.50	24.28	23.78	

OUTPUT POWER FOR 5G NR n41 (20.0 MHz)

Bandwidth (MHz)	Modulation	RB Allocation	RB Offset	Conducted Average (dBm)											
				ANT 2			ANT 1			ANT 4			ANT 3		
				501200	518600	536000	501200	518600	536000	501200	518600	536000	501200	518600	536000
20.0	BPSK	1	0	22.50	25.20	24.48	22.20	24.87	23.97	20.76	24.06	22.80	20.09	24.50	23.45
		1	1	22.33	28.15	27.69	22.12	28.55	27.70	20.80	27.65	26.30	20.14	27.88	27.00
		1	49	28.00	28.59	28.00	27.70	28.63	27.16	26.28	27.70	26.03	26.20	27.84	26.91
		1	50	25.40	26.42	25.39	24.28	26.19	24.64	23.71	24.68	23.39	22.83	25.49	25.15
		25	12	24.50	28.64	27.77	24.20	28.59	27.11	22.74	27.54	26.09	22.68	27.22	26.87
		50	0	24.48	28.70	27.61	24.20	28.70	27.40	22.80	27.58	25.70	22.60	28.00	26.87
	QPSK	1	0	21.89	25.16	24.50	21.59	25.12	24.20	20.25	23.97	22.42	19.53	24.46	23.50
		1	1	22.00	28.09	27.18	21.52	28.31	27.12	20.36	27.63	25.75	19.60	27.13	26.89
		1	49	27.88	28.00	27.83	26.95	28.08	26.47	26.30	27.12	25.34	26.14	27.17	26.96
		1	50	25.47	26.50	25.29	24.30	26.12	24.63	23.77	24.79	23.22	22.84	25.57	25.18
		25	12	23.39	28.58	27.15	23.04	28.08	26.70	21.73	27.40	25.43	21.68	27.91	26.80
		50	0	23.39	28.14	26.67	23.21	27.59	26.04	21.76	26.79	24.82	21.61	27.12	26.82
	16QAM	1	0	22.07	25.04	24.08	21.47	24.81	24.16	20.25	24.20	22.21	19.81	24.38	23.40
		1	1	21.76	28.06	26.48	21.62	27.66	26.60	20.23	27.17	25.41	19.44	26.59	26.70
		1	49	27.76	27.31	27.26	25.93	27.55	25.78	25.87	26.44	24.85	25.67	26.41	26.95
		1	50	25.63	26.35	25.58	24.33	26.13	24.66	24.00	24.77	23.39	22.76	25.51	25.09
		25	12	22.83	28.33	26.56	22.49	27.37	25.81	21.23	26.81	24.83	21.11	26.83	26.95
		50	0	22.85	27.60	25.95	22.64	26.62	25.06	21.26	26.23	24.20	21.11	26.07	26.45
	64QAM	1	0	21.52	24.86	23.66	20.90	25.20	24.10	19.73	23.89	22.49	18.92	24.22	23.30
		1	1	21.04	26.54	25.36	-0.64	26.39	25.60	19.59	25.95	24.15	19.10	25.26	26.03
		1	49	25.99	26.61	26.33	24.71	25.97	24.43	24.78	25.67	23.67	23.72	25.47	25.63
		1	50	25.13	26.38	25.42	24.28	26.14	24.46	23.70	24.76	23.32	22.85	25.38	25.18
		25	12	22.86	27.14	25.51	22.60	26.22	24.84	21.22	25.69	24.02	21.25	25.94	26.05
		50	0	22.85	27.00	25.71	22.56	26.22	24.85	21.23	25.79	23.99	21.12	25.81	26.02
	256QAM	1	0	19.69	23.87	22.37	19.42	23.83	23.20	18.06	23.41	21.71	17.63	22.72	22.41
		1	1	19.69	24.37	24.54	19.55	24.98	23.74	18.30	24.11	22.79	17.47	23.70	24.17
		1	49	24.25	25.33	24.05	23.17	24.76	23.47	22.70	23.63	22.44	21.49	24.04	23.93
		1	50	24.05	25.38	24.08	23.38	24.37	23.50	22.55	23.80	22.55	21.90	23.96	24.14
25		12	21.35	25.08	24.49	21.10	24.94	23.70	19.64	23.92	22.72	19.52	24.43	24.08	
50		0	21.35	25.10	24.59	21.08	24.82	23.67	19.62	23.84	22.62	19.54	24.43	24.02	

OUTPUT POWER FOR 5G NR n41 (30.0 MHz)

Bandwidth (MHz)	Modulation	RB Allocation	RB Offset	Conducted Average (dBm)											
				ANT 2			ANT 1			ANT 4			ANT 3		
				502200	518600	525000	502200	518600	525000	502200	518600	525000	502200	518600	525000
30.0	BPSK	1	0	22.39	25.20	24.27	21.89	24.75	24.02	20.75	24.14	22.80	19.94	27.86	26.96
		1	1	22.50	28.00	28.00	21.83	28.36	27.70	20.80	27.68	26.27	19.85	27.96	26.89
		1	76	27.85	28.33	27.25	27.70	28.70	26.99	26.30	27.70	26.05	26.20	25.56	25.17
		1	77	25.17	26.52	24.52	24.09	26.03	24.27	23.54	24.88	23.25	22.74	27.88	26.82
		36	18	24.31	28.70	26.61	24.00	28.44	27.26	22.80	27.60	26.08	22.60	28.00	26.83
		75	0	24.50	28.61	26.72	24.00	28.28	27.07	22.71	27.68	25.94	22.66	24.50	23.26
	QPSK	1	0	21.94	25.16	24.32	21.45	24.86	24.14	20.22	24.05	22.29	19.42	27.40	26.90
		1	1	21.98	27.75	27.99	21.44	28.31	27.05	20.22	27.56	26.30	19.52	27.23	26.84
		1	76	28.00	27.79	26.83	27.14	28.16	26.33	26.07	27.06	25.28	26.15	25.56	25.14
		1	77	25.08	26.45	24.45	24.19	25.97	24.33	23.50	25.10	23.15	22.84	27.63	26.81
		36	18	23.27	28.64	26.05	22.96	28.06	26.77	21.83	27.41	25.61	21.58	26.63	26.82
		75	0	23.47	27.89	25.89	22.98	26.99	25.79	21.85	26.80	25.00	21.55	24.30	23.50
	16QAM	1	0	21.99	24.84	24.18	21.46	24.66	23.84	20.41	23.93	22.53	19.10	26.49	27.00
		1	1	22.08	26.82	27.45	21.00	27.26	26.60	20.16	27.49	25.53	19.41	26.36	26.96
		1	76	27.92	27.01	26.25	26.14	27.38	25.49	25.36	26.57	24.69	25.08	25.62	24.95
		1	77	25.24	26.33	24.04	24.37	25.92	24.34	23.67	25.03	23.12	22.80	26.81	26.78
		36	18	22.76	28.29	25.46	22.38	27.15	25.86	21.30	26.81	25.01	21.06	25.75	26.65
		75	0	22.85	27.36	25.34	22.59	26.37	25.00	21.30	26.24	24.35	21.06	24.32	23.21
	64QAM	1	0	21.42	24.85	24.50	20.78	25.20	24.20	19.77	24.20	22.28	18.98	25.30	26.16
		1	1	21.46	25.92	26.47	20.85	26.14	25.26	19.36	25.96	24.20	19.26	25.25	25.77
		1	76	26.29	26.36	25.22	24.91	26.02	24.26	24.54	25.83	23.72	23.66	25.22	24.98
		1	77	25.35	26.31	24.29	24.37	25.79	24.22	23.39	25.07	23.66	22.68	25.59	26.06
		36	18	22.65	27.06	24.49	22.49	26.09	24.70	21.33	25.75	24.07	21.08	25.38	26.12
		75	0	22.93	27.01	25.06	22.47	25.83	24.55	21.34	25.81	24.14	21.05	22.94	22.09
	256QAM	1	0	19.65	23.76	23.23	19.44	23.60	23.01	18.06	23.13	21.64	17.43	24.12	24.37
		1	1	19.38	24.19	23.91	19.31	24.68	23.24	18.22	23.94	22.80	17.28	23.96	24.28
		1	76	24.44	25.22	23.25	23.08	24.50	23.22	22.39	23.87	22.54	21.80	23.74	24.27
		1	77	24.03	25.18	23.21	23.12	24.76	22.86	22.43	24.17	22.38	21.76	24.22	23.98
		36	18	21.36	24.97	23.50	21.03	24.79	23.13	19.65	23.79	22.51	19.50	24.21	24.10
		75	0	21.52	24.93	23.99	21.06	24.59	23.19	19.75	23.99	22.60	19.54	24.21	24.10

OUTPUT POWER FOR 5G NR n41 (40.0 MHz)

Bandwidth (MHz)	Modulation	RB Allocation	RB Offset	Conducted Average (dBm)											
				ANT 2			ANT 1			ANT 4			ANT 3		
				503200	518600	534000	503200	518600	534000	503200	518600	534000	503200	518600	534000
40.0	BPSK	1	0	22.36	25.05	23.93	21.83	25.09	23.69	20.80	23.98	22.80	19.97	24.50	23.43
		1	1	22.44	27.68	27.01	21.95	28.52	27.70	20.77	27.62	26.30	19.98	27.76	26.96
		1	104	28.00	28.46	25.40	27.70	28.70	26.97	26.30	27.65	26.11	26.20	28.00	26.88
		1	105	25.57	26.42	24.73	23.96	26.20	24.34	23.43	24.62	24.65	22.83	25.43	25.08
		50	25	24.19	28.70	27.16	23.78	28.65	27.31	22.77	27.43	26.14	22.62	27.74	26.86
		100	0	24.42	28.63	27.68	23.98	28.67	27.28	22.80	27.47	26.20	22.60	27.85	26.78
	QPSK	1	0	21.66	25.12	24.50	21.25	25.20	23.74	20.31	23.78	22.30	19.60	24.41	23.50
		1	1	21.94	26.99	28.00	21.40	28.39	26.98	20.32	27.70	26.29	19.56	27.60	26.82
		1	104	27.94	27.91	27.14	26.93	28.10	26.27	26.27	26.87	25.31	26.18	27.09	26.90
		1	105	25.53	26.35	25.77	24.11	26.23	24.27	23.42	24.61	24.52	22.80	25.44	25.15
		50	25	22.99	28.68	27.31	22.88	28.36	26.97	21.85	27.34	25.94	21.59	27.81	26.77
		100	0	22.69	27.78	26.95	22.90	27.57	25.87	21.91	26.81	25.37	21.65	27.04	26.79
	16QAM	1	0	21.02	25.20	24.41	21.44	24.92	24.20	19.78	24.20	22.05	19.40	24.35	23.20
		1	1	21.04	26.45	27.67	21.42	27.62	26.31	20.33	27.19	26.13	19.54	26.87	27.00
		1	104	26.06	27.38	26.54	26.21	27.34	25.40	25.78	26.13	24.43	25.13	26.26	26.49
		1	105	24.97	26.32	25.73	23.85	26.53	24.17	23.53	24.72	24.05	22.52	25.44	25.23
		50	25	22.44	28.32	26.74	22.28	27.67	26.29	21.34	26.75	25.38	21.19	26.99	26.87
		100	0	22.78	27.16	26.28	22.44	26.71	25.25	21.31	26.18	24.69	21.12	25.92	26.44
	64QAM	1	0	20.83	24.91	24.36	21.02	25.14	24.12	19.64	24.18	22.52	18.86	24.45	23.50
		1	1	20.60	25.49	26.60	20.86	26.31	24.80	19.95	25.65	24.88	19.02	25.14	25.97
		1	104	25.13	26.04	25.41	25.07	26.10	24.60	24.54	25.26	23.48	23.69	24.86	25.36
		1	105	24.94	26.37	25.51	24.11	26.18	24.67	23.69	24.56	23.59	22.52	24.76	24.98
		50	25	22.18	27.14	25.86	22.33	26.48	25.36	21.43	25.63	24.44	21.17	25.86	26.12
		100	0	22.52	26.85	26.02	22.33	26.30	24.94	21.35	25.67	24.44	21.09	25.55	26.02
	256QAM	1	0	19.47	24.05	23.54	19.17	23.96	23.04	18.06	22.88	21.56	17.13	23.01	22.33
		1	1	19.60	23.98	24.94	19.39	25.01	23.24	18.46	23.97	23.74	17.39	23.89	23.93
		1	104	22.75	24.92	24.26	22.87	24.57	22.97	22.60	23.64	22.40	21.83	23.34	24.12
		1	105	22.44	24.98	24.30	22.85	24.85	23.19	22.74	23.63	22.33	21.65	23.66	23.83
		50	25	20.69	25.03	24.94	20.78	25.03	23.19	19.84	23.78	23.34	19.59	24.13	24.01
		100	0	20.61	24.97	24.99	20.77	24.84	23.26	19.89	23.85	23.37	19.59	24.14	24.10

OUTPUT POWER FOR 5G NR n41 (50.0 MHz)

Bandwidth (MHz)	Modulation	RB Allocation	RB Offset	Conducted Average (dBm)											
				ANT 2			ANT 1			ANT 4			ANT 3		
				504200	518600	533000	504200	518600	533000	504200	518600	533000	504200	518600	533000
50.0	BPSK	1	0	22.10	24.99	24.35	22.12	25.20	24.59	20.80	24.20	22.80	20.01	24.50	23.48
		1	1	21.98	27.16	26.84	22.20	28.70	27.70	20.58	27.70	26.02	20.17	27.65	26.94
		1	131	27.95	28.56	27.47	27.70	28.44	27.12	26.23	27.70	26.30	26.17	28.00	26.95
		1	132	25.45	26.00	25.61	24.06	25.95	24.68	23.69	24.78	24.59	22.80	25.38	25.08
		64	32	24.20	28.70	28.00	24.18	28.54	27.65	22.80	27.62	26.11	22.69	27.74	26.89
		128	0	24.52	28.38	27.32	24.20	27.91	26.31	22.73	27.62	26.13	22.65	26.91	26.88
	QPSK	1	0	21.53	24.90	24.34	21.62	25.15	24.71	20.11	24.12	22.54	19.61	24.40	23.50
		1	1	21.73	26.61	26.20	21.68	27.76	27.02	20.29	27.64	26.06	19.55	27.61	27.00
		1	131	28.00	28.12	26.99	26.87	27.75	26.36	26.30	27.57	25.83	26.20	27.12	26.94
		1	132	25.42	25.82	25.34	24.04	26.00	24.80	23.66	24.66	24.58	22.92	25.27	25.04
		64	32	23.26	28.64	27.54	23.25	27.68	26.95	21.77	27.58	26.14	21.65	26.82	26.91
		128	0	23.51	27.52	26.50	23.12	26.69	25.58	21.73	27.32	26.05	21.63	25.99	26.67
	16QAM	1	0	21.22	25.20	24.50	21.56	25.17	24.72	20.17	24.11	22.41	19.41	24.40	23.35
		1	1	21.83	26.47	25.85	21.66	27.01	26.34	20.29	27.48	26.09	19.52	26.48	26.61
		1	131	27.78	27.40	26.06	25.74	26.79	25.87	26.09	27.13	25.32	25.38	26.61	26.74
		1	132	25.57	26.05	25.69	24.22	26.18	24.82	23.56	24.90	24.43	22.83	25.51	25.25
		64	32	22.76	28.04	27.03	22.67	27.15	26.03	21.25	27.20	26.10	21.20	26.26	26.85
		128	0	22.96	26.88	25.91	22.64	25.94	25.00	21.20	26.18	25.44	21.15	25.23	26.06
	64QAM	1	0	21.10	24.78	24.19	21.07	24.99	24.51	19.91	24.10	22.49	18.53	24.30	23.40
		1	1	21.41	25.43	25.07	-0.64	25.60	24.58	19.68	25.80	25.64	18.95	25.43	25.64
		1	131	26.35	26.67	25.50	24.94	25.54	24.52	24.63	25.75	24.19	23.76	24.67	25.41
		1	132	25.38	26.10	25.42	24.11	25.46	24.46	23.42	24.50	24.14	22.66	24.87	25.07
		64	32	22.78	27.19	26.12	22.74	25.71	25.04	21.27	25.74	25.17	21.26	25.18	25.85
		128	0	22.99	26.62	25.66	22.70	25.49	24.54	21.25	25.68	25.13	21.14	24.91	25.62
	256QAM	1	0	19.13	23.79	22.93	19.64	23.57	23.39	18.05	23.26	21.52	17.63	23.12	22.30
		1	1	19.54	24.35	23.75	19.47	24.18	23.41	18.24	23.86	23.92	17.53	24.00	24.07
		1	131	24.13	24.78	24.17	22.98	24.36	22.75	22.62	23.88	23.34	21.62	23.57	24.34
		1	132	24.56	24.67	24.12	23.32	24.36	23.03	22.53	23.57	23.21	21.61	23.22	23.92
		64	32	21.17	25.17	25.11	21.20	24.46	23.60	19.72	23.73	23.97	19.66	23.76	24.12
		128	0	21.45	25.00	24.55	21.13	24.18	23.20	19.57	23.73	23.85	19.62	23.35	24.10

OUTPUT POWER FOR 5G NR n41 (60.0 MHz)

Bandwidth (MHz)	Modulation	RB Allocation	RB Offset	Conducted Average (dBm)											
				ANT 2			ANT 1			ANT 4			ANT 3		
				505200	518600	532000	505200	518600	532000	505200	518600	532000	505200	518600	532000
60.0	BPSK	1	0	22.50	27.34	26.51	21.88	25.01	24.20	20.73	24.15	22.80	20.00	24.27	23.34
		1	1	27.68	28.01	27.30	21.90	28.59	27.70	20.80	27.68	26.07	20.07	27.59	26.78
		1	160	25.09	25.49	25.54	27.70	28.62	26.54	26.29	27.59	26.25	26.17	28.00	27.00
		1	161	24.48	28.70	28.00	24.08	26.18	25.20	23.84	24.63	24.70	22.78	25.36	26.14
		81	40	24.50	28.25	27.15	23.92	28.70	27.01	22.80	27.70	26.23	22.70	27.27	26.95
		162	0	21.82	25.01	24.21	23.94	28.57	26.58	22.77	27.62	26.21	22.64	27.79	26.92
	QPSK	1	0	21.86	26.90	26.38	21.39	25.12	24.19	20.29	24.06	22.24	19.42	24.48	23.41
		1	1	27.64	27.88	26.76	21.40	27.75	26.79	20.19	27.63	26.10	19.55	27.59	26.89
		1	160	25.05	25.31	25.32	27.07	27.72	25.89	26.30	27.68	25.94	26.20	27.21	26.75
		1	161	23.45	28.45	27.43	24.09	25.91	25.01	23.70	24.66	24.53	22.85	25.32	26.12
		81	40	23.51	27.46	26.34	22.88	27.85	26.36	21.80	27.67	26.21	21.69	26.76	26.93
		162	0	21.91	25.20	24.50	22.91	26.86	25.07	21.80	27.38	26.19	21.62	26.26	26.77
	16QAM	1	0	22.18	26.27	26.25	21.23	25.20	24.02	20.15	24.01	22.33	19.07	24.50	23.50
		1	1	28.00	27.39	26.20	21.61	27.18	25.91	20.43	27.39	26.30	19.59	27.10	26.94
		1	160	24.89	25.69	25.30	26.39	27.11	25.15	26.17	27.21	25.38	25.38	26.26	26.62
		1	161	22.97	27.91	26.94	24.09	26.03	24.20	23.85	24.86	24.65	22.78	25.29	25.53
		81	40	23.00	26.83	25.72	22.50	27.21	25.50	21.30	27.32	26.23	21.23	26.15	26.93
		162	0	21.62	24.73	24.23	22.44	26.22	24.45	21.22	26.29	25.62	21.25	25.32	26.10
	64QAM	1	0	21.58	25.37	25.02	21.20	24.66	23.55	19.56	24.20	21.90	18.99	24.45	23.10
		1	1	26.05	26.18	25.43	20.82	25.85	24.38	19.91	25.96	25.50	19.07	25.57	26.05
		1	160	25.09	25.32	25.05	24.94	25.69	23.83	24.63	25.55	24.18	23.47	25.25	25.55
		1	161	22.94	27.00	25.97	24.17	26.13	23.94	23.63	24.93	24.43	23.01	25.09	25.25
		81	40	22.93	26.56	25.48	22.43	25.99	24.27	21.32	25.82	25.55	21.37	24.89	26.05
		162	0	20.01	23.68	23.36	22.44	25.94	24.13	21.26	25.85	25.35	21.27	24.83	25.72
	256QAM	1	0	19.70	24.05	23.47	19.20	23.32	22.19	18.00	23.17	21.49	17.23	23.46	21.68
		1	1	23.66	24.40	23.89	19.58	24.79	22.98	18.27	24.09	23.72	17.75	23.71	24.68
		1	160	24.07	24.28	24.37	23.06	24.20	22.51	22.40	23.92	23.40	21.80	23.81	24.13
		1	161	21.44	25.15	25.01	23.00	24.68	22.71	22.91	23.83	23.22	21.76	23.54	24.30
		81	40	21.50	24.87	24.49	20.87	24.73	22.99	19.71	23.79	24.04	19.70	23.71	24.59
		162	0	22.07	24.87	24.49	20.81	24.40	22.79	19.67	23.85	23.99	19.68	23.51	24.43

OUTPUT POWER FOR 5G NR n41 (70.0 MHz)

Bandwidth (MHz)	Modulation	RB Allocation	RB Offset	Conducted Average (dBm)											
				ANT 2			ANT 1			ANT 4			ANT 3		
				506200	518600	531000	506200	518600	531000	506200	518600	531000	506200	518600	531000
70.0	BPSK	1	0	22.50	23.20	24.43	22.20	23.20	24.09	20.74	22.20	22.77	20.55	22.50	23.43
		1	1	22.34	23.45	27.29	21.91	23.98	27.70	20.80	23.02	26.26	20.70	22.98	27.00
		1	187	28.00	27.70	27.51	27.70	28.60	26.30	26.27	27.54	26.30	25.96	28.00	26.86
		1	188	25.98	24.98	25.46	25.26	26.06	25.15	24.99	24.66	25.03	24.43	25.43	26.12
		90	45	24.50	28.70	28.00	24.20	28.70	27.13	21.64	27.65	26.16	22.01	27.83	26.94
		180	0	24.35	28.18	27.51	24.19	28.54	26.69	21.57	27.69	26.12	21.91	27.96	26.94
	QPSK	1	0	21.72	22.63	24.50	21.65	22.69	24.20	20.32	21.59	22.52	19.97	22.07	23.50
		1	1	22.01	23.04	27.35	21.79	23.54	26.74	20.17	22.42	26.00	20.21	22.64	26.91
		1	187	27.64	27.50	27.32	27.04	27.83	25.74	26.30	27.45	26.24	25.87	27.72	26.63
		1	188	25.86	25.20	25.51	25.12	26.15	24.84	25.10	24.82	25.05	24.40	25.39	26.18
		90	45	23.49	28.43	27.70	23.17	27.90	26.07	20.68	27.70	26.09	20.99	26.56	26.91
		180	0	23.33	27.39	26.69	23.19	26.84	25.19	20.66	27.41	26.14	20.95	26.60	26.89
	16QAM	1	0	21.59	22.51	24.36	21.59	22.48	23.62	20.08	21.74	22.44	19.85	22.19	23.39
		1	1	21.97	22.82	27.40	21.57	23.31	25.80	20.30	22.59	25.96	20.02	23.00	27.00
		1	187	27.09	27.07	26.33	26.41	26.75	24.92	26.12	27.21	25.81	26.20	26.87	26.86
		1	188	25.60	24.90	25.66	24.62	25.81	24.34	25.25	24.75	24.61	24.93	25.42	25.98
		90	45	22.95	27.82	27.12	22.69	27.07	25.65	20.19	27.48	26.10	20.53	26.33	26.98
		180	0	22.74	26.80	26.07	22.78	26.03	24.58	20.19	26.43	26.12	20.46	25.71	26.38
	64QAM	1	0	21.25	21.68	24.42	21.21	22.29	23.41	19.71	21.01	22.80	19.64	21.47	23.23
		1	1	21.17	22.44	25.99	-0.64	23.25	24.67	19.86	22.20	25.40	19.43	22.16	26.59
		1	187	26.21	26.11	25.33	25.31	25.49	23.61	25.76	25.78	25.37	24.91	25.83	25.55
		1	188	25.34	25.42	25.36	25.03	25.48	23.68	24.86	24.74	25.00	24.41	25.42	25.56
		90	45	22.97	26.87	26.23	22.70	25.79	24.23	20.22	25.97	26.13	20.61	24.98	26.15
		180	0	22.78	26.55	25.77	22.77	25.71	24.17	20.15	25.87	26.10	20.46	25.37	26.00
	256QAM	1	0	19.82	20.53	23.31	20.08	21.02	22.50	18.10	19.60	21.61	17.86	19.71	21.87
		1	1	19.63	20.91	24.40	19.68	21.56	23.37	18.31	20.33	24.11	18.17	20.54	24.81
		1	187	24.95	23.96	24.53	23.69	24.37	22.61	24.10	23.90	24.32	23.33	24.19	24.32
		1	188	24.37	23.70	24.50	23.90	24.29	22.50	23.96	24.03	23.47	23.39	24.00	24.20
		90	45	21.44	25.03	24.95	21.24	24.50	22.73	18.63	23.90	23.97	18.99	23.58	24.78
		180	0	21.23	24.77	24.68	21.15	24.36	22.68	18.62	23.94	24.04	18.97	23.84	24.67

OUTPUT POWER FOR 5G NR n41 (80.0 MHz)

Bandwidth (MHz)	Modulation	RB Allocation	RB Offset	Conducted Average (dBm)											
				ANT 2			ANT 1			ANT 4			ANT 3		
				507200	518600	530000	507200	518600	530000	507200	518600	530000	507200	518600	530000
80.0	BPSK	1	0	22.50	23.20	24.19	22.20	23.20	24.04	20.76	22.20	20.64	22.50	23.49	
		1	1	22.27	23.93	28.00	22.17	24.15	27.70	20.80	23.11	26.27	20.70	23.02	27.00
		1	215	28.00	27.77	27.48	27.70	28.62	26.31	26.08	27.68	25.70	26.09	27.89	26.88
		1	216	26.03	24.92	25.25	25.18	26.03	25.32	25.06	24.84	23.28	24.57	25.59	26.13
		108	54	24.50	28.70	27.57	24.20	28.70	27.19	21.75	27.67	26.30	21.27	28.00	26.81
		216	0	24.08	28.27	27.39	24.17	28.01	26.96	21.68	27.70	26.30	21.23	27.97	26.83
	QPSK	1	0	21.71	23.01	24.41	21.61	22.55	24.08	20.28	21.58	22.72	20.21	22.00	23.50
		1	1	21.94	23.37	27.54	21.52	23.76	26.77	20.32	22.56	26.20	20.09	22.45	26.98
		1	215	27.65	27.16	26.93	26.71	27.82	25.72	25.89	27.69	25.25	26.20	27.41	26.84
		1	216	26.05	25.05	25.39	25.34	26.44	24.89	25.10	24.70	23.31	24.51	25.45	26.12
		108	54	23.44	28.33	27.36	23.12	28.03	26.48	20.77	27.68	26.24	20.28	27.32	26.80
		216	0	22.98	27.46	26.61	23.21	27.21	25.50	20.76	27.40	25.70	20.23	26.81	26.86
	16QAM	1	0	22.20	22.99	24.50	21.42	22.72	24.20	20.27	21.69	22.80	19.55	22.16	23.27
		1	1	21.92	23.37	26.91	21.29	23.85	25.77	20.11	22.52	26.01	20.27	22.75	26.56
		1	215	26.87	26.73	26.30	26.41	26.76	24.97	25.95	27.20	24.90	25.69	27.16	26.60
		1	216	26.19	25.19	25.55	25.50	25.88	24.05	25.08	25.00	23.06	24.35	25.58	25.45
		108	54	22.91	27.83	26.76	22.60	27.86	25.83	20.24	27.33	25.88	19.71	26.25	26.83
		216	0	22.47	26.90	25.96	22.71	26.37	24.85	20.20	26.35	24.99	19.69	26.03	26.40
	64QAM	1	0	20.93	22.61	24.13	20.89	22.67	23.68	19.39	21.48	22.76	19.65	21.31	23.22
		1	1	21.53	22.90	25.83	-0.64	23.10	24.87	20.21	21.93	24.22	19.97	22.25	26.15
		1	215	26.00	26.09	25.01	25.45	25.53	24.02	26.30	25.44	23.79	24.84	25.74	25.56
		1	216	25.90	24.93	25.01	25.30	25.64	23.53	24.84	24.42	23.04	24.77	25.29	25.02
		108	54	22.94	26.94	25.87	22.63	25.94	24.53	20.30	25.93	24.43	19.79	24.96	26.08
		216	0	22.48	26.65	25.71	22.63	25.89	24.36	20.21	25.86	24.42	19.70	25.53	25.96
	256QAM	1	0	19.42	20.76	23.25	19.91	20.92	22.28	18.25	19.63	21.79	18.02	20.09	22.14
		1	1	19.47	21.28	24.80	19.40	22.02	23.33	18.21	20.54	22.19	18.03	20.32	25.09
		1	215	24.71	24.11	24.00	23.63	24.09	22.78	24.04	23.60	22.50	23.38	23.71	24.28
		1	216	24.45	24.03	23.59	23.92	24.56	22.56	23.85	23.82	22.45	24.13	23.82	24.22
		108	54	21.30	25.06	24.68	21.18	24.69	23.10	18.83	23.96	22.39	18.29	23.78	24.53
		216	0	20.93	24.85	24.62	21.17	24.53	23.07	18.68	23.87	22.34	18.23	24.09	24.66

OUTPUT POWER FOR 5G NR n41 (90.0 MHz)

Bandwidth (MHz)	Modulation	RB Allocation	RB Offset	Conducted Average (dBm)											
				ANT 2			ANT 1			ANT 4			ANT 3		
				508200	518600	529000	508200	518600	529000	508200	518600	529000	508200	518600	529000
90.0	BPSK	1	0	22.50	23.20	24.32	22.16	23.20	24.03	20.73	22.20	22.66	20.58	22.50	23.30
		1	1	22.41	24.16	28.00	22.20	24.04	27.70	20.80	22.81	26.01	20.70	22.96	26.21
		1	243	28.00	27.50	27.23	27.70	28.46	26.51	26.24	27.59	26.04	26.20	28.00	26.35
		1	244	26.07	25.29	25.20	25.61	26.29	25.32	24.83	24.53	25.05	24.71	25.24	25.63
		120	60	24.21	28.70	27.15	24.20	28.70	27.26	21.74	27.57	26.00	21.53	27.85	27.00
		243	0	23.79	28.32	27.14	24.13	28.28	27.28	21.75	27.65	25.98	21.46	27.95	26.36
	QPSK	1	0	21.76	22.86	24.44	21.91	22.86	24.00	20.40	21.72	22.80	20.09	21.86	23.50
		1	1	21.66	23.84	27.62	21.70	23.56	26.98	20.23	22.46	25.60	20.26	22.57	26.36
		1	243	27.99	27.06	26.62	27.12	27.55	25.71	26.11	27.70	26.18	26.20	27.38	26.26
		1	244	26.15	25.37	25.14	25.62	26.32	25.08	24.81	24.79	24.99	24.79	25.35	25.56
		120	60	23.18	28.27	27.07	23.17	27.65	26.44	20.77	27.63	26.06	20.53	26.73	26.24
		243	0	22.76	27.58	26.31	23.11	27.07	25.80	20.67	27.28	26.01	20.51	26.69	26.35
	16QAM	1	0	21.72	22.96	24.50	21.70	22.66	24.20	20.13	21.28	22.30	20.60	21.78	23.03
		1	1	21.72	23.63	26.62	21.44	23.52	25.90	19.82	22.32	25.75	20.27	22.60	26.40
		1	243	27.90	26.65	25.56	26.58	26.87	25.00	26.30	27.42	26.30	25.99	26.68	25.95
		1	244	26.07	25.37	25.48	25.64	25.53	24.37	24.80	24.66	25.15	24.40	25.23	25.17
		120	60	22.69	27.73	26.53	22.54	26.98	25.73	20.37	27.22	26.05	20.05	26.53	26.22
		243	0	22.22	26.99	25.77	22.66	26.07	24.94	20.22	26.36	25.99	19.98	26.00	25.89
	64QAM	1	0	21.40	22.33	24.07	21.31	22.24	23.56	19.64	21.21	22.59	19.32	21.41	23.19
		1	1	20.84	23.39	26.06	-0.64	23.33	25.13	19.83	22.04	25.71	19.65	21.73	25.81
		1	243	26.98	25.77	24.91	25.03	25.82	23.78	25.73	25.75	25.48	25.22	25.37	24.40
		1	244	25.77	25.17	25.12	25.15	25.00	24.11	24.99	24.87	25.34	24.59	25.17	24.54
		120	60	22.70	26.84	25.62	22.70	25.89	24.35	20.41	25.89	26.04	20.00	25.03	25.50
		243	0	22.18	26.71	25.46	22.64	25.78	24.46	20.28	25.82	26.05	19.95	25.61	25.45
	256QAM	1	0	19.19	20.76	23.32	19.38	20.64	22.65	18.28	19.68	21.39	18.39	19.85	22.36
		1	1	19.72	21.23	24.94	19.59	21.46	23.69	17.94	20.08	23.96	17.87	20.18	24.51
		1	243	24.84	24.20	24.11	23.96	23.84	22.35	24.19	24.18	23.97	23.67	23.99	23.27
		1	244	24.79	24.06	23.59	23.84	23.59	22.50	23.85	23.75	23.74	23.87	23.80	23.48
		120	60	21.10	25.09	24.08	21.07	24.41	22.91	18.88	23.76	23.95	18.48	23.61	24.10
		243	0	20.59	24.77	24.31	21.02	24.30	23.17	18.80	23.84	22.67	18.48	24.12	24.13

OUTPUT POWER FOR 5G NR n41 (100.0 MHz)

Bandwidth (MHz)	Modulation	RB Allocation	RB Offset	Conducted Average (dBm)											
				ANT 2			ANT 1			ANT 4			ANT 3		
				509200	528600	528000	509200	528600	528000	509200	528600	528000	509200	528600	528000
100.0	BPSK	1	0	22.50	23.20	24.32	22.20	23.20	23.86	17.22	22.20	22.80	20.52	22.50	23.47
		1	1	22.48	24.83	27.91	22.08	24.00	27.32	20.47	22.97	26.30	20.70	22.87	26.59
		1	271	28.00	27.58	27.47	27.70	27.92	26.04	26.08	27.64	25.61	26.12	27.79	26.45
		1	272	26.01	25.43	25.48	25.65	26.11	25.11	26.30	24.72	23.31	24.52	25.43	25.99
		135	67	24.50	28.70	27.45	24.20	28.48	27.10	22.80	27.63	26.18	22.34	26.39	26.61
		270	0	24.19	28.32	27.47	24.12	28.70	27.70	20.01	27.70	26.13	22.25	28.00	27.00
	QPSK	1	0	21.95	22.93	24.50	21.56	22.88	24.20	16.99	21.67	22.78	20.16	22.11	23.50
		1	1	21.85	24.33	27.83	21.59	23.58	26.49	20.32	22.49	26.25	20.13	22.43	26.63
		1	271	27.64	26.83	26.93	27.14	26.98	25.62	26.01	27.68	25.08	26.00	27.19	26.56
		1	272	25.81	25.57	25.40	25.71	26.02	24.64	25.32	24.81	23.13	24.53	25.22	26.13
		135	67	23.46	28.10	27.29	23.19	27.76	26.51	21.77	27.69	26.15	21.27	26.72	26.61
		270	0	23.20	27.53	26.64	23.03	27.07	25.72	19.96	27.42	25.36	21.20	26.94	26.59
	16QAM	1	0	22.29	22.55	24.31	21.53	23.03	24.19	16.72	21.87	22.62	20.23	21.79	23.32
		1	1	22.17	23.74	28.00	21.66	23.79	25.83	20.64	22.68	25.59	20.09	22.92	26.60
		1	271	27.63	26.69	26.24	26.70	26.38	24.82	26.17	27.59	24.47	26.20	26.48	25.77
		1	272	25.79	25.48	25.81	25.32	25.50	23.84	24.76	25.16	23.01	24.48	25.61	25.44
		135	67	22.97	27.51	26.72	22.71	26.99	25.80	21.27	27.45	25.73	20.74	26.73	26.65
		270	0	22.64	26.92	26.07	22.62	26.20	24.88	19.67	26.39	24.77	20.74	26.10	26.32
	64QAM	1	0	21.77	22.27	24.24	20.95	22.20	23.53	16.30	21.11	22.58	19.58	21.68	23.48
		1	1	21.08	23.84	27.25	-0.64	22.61	24.51	20.80	22.33	23.81	19.33	21.83	26.11
		1	271	26.87	25.57	25.23	25.14	25.10	23.46	25.96	25.90	23.56	24.31	25.02	24.89
		1	272	26.05	25.68	25.23	25.12	25.04	23.51	24.82	24.89	22.89	24.74	24.77	24.85
		135	67	22.95	26.56	25.73	22.64	25.90	24.25	21.28	25.89	24.25	20.82	25.13	25.55
		270	0	22.61	26.61	25.75	22.61	25.74	24.45	17.85	25.93	24.19	20.65	25.53	25.91
	256QAM	1	0	19.86	20.47	23.10	19.34	20.34	21.92	15.14	19.56	22.16	18.25	19.44	22.03
		1	1	19.84	21.50	24.67	19.46	21.50	23.32	18.35	20.69	22.83	17.70	20.24	24.39
		1	271	24.51	24.68	23.68	24.07	23.72	22.45	24.70	23.91	22.36	23.15	23.49	23.50
		1	272	24.50	24.60	23.97	23.47	23.43	22.42	23.40	23.92	22.24	23.06	23.10	23.50
		135	67	21.38	25.22	24.39	21.14	24.43	22.72	19.88	24.01	22.28	19.29	23.78	24.29
		270	0	21.08	25.02	24.67	21.08	24.50	23.11	21.83	23.90	22.26	19.22	24.22	24.53

8.11. LTE BAND 66 AND 5G NR n66

LTE BAND 66

Test Engineer ID:	32061	Test Date:	2024-03-02
-------------------	-------	------------	------------

OUTPUT POWER FOR LTE BAND 66 (1.4 MHz)

Bandwidth (MHz)	Modulation	RB Allocation	RB Offset	Conducted Average (dBm)											
				ANT 1			ANT 2			ANT 3			ANT 4		
				131979	132322	132665	131979	132322	132665	131979	132322	132665	131979	132322	132665
1.4	QPSK	1	0	25.44	25.64	25.56	25.70	25.65	25.62	25.42	25.33	25.39	25.08	25.02	25.20
		1	2	25.46	25.70	25.58	25.66	25.66	25.64	25.50	25.42	25.38	25.05	25.01	25.19
		1	5	25.50	25.63	25.55	25.61	25.62	25.58	25.46	25.38	25.39	24.99	24.99	25.18
		3	0	25.49	25.60	25.53	25.64	25.63	25.57	25.46	25.38	25.37	24.97	24.97	25.17
		3	1	25.52	25.60	25.55	25.66	25.63	25.56	25.47	25.38	25.39	25.00	24.99	25.17
		3	2	25.48	25.61	25.58	25.64	25.65	25.59	25.50	25.38	25.38	24.97	24.99	25.16
	16QAM	6	0	25.09	25.22	25.18	25.20	25.21	25.15	24.89	24.77	24.77	24.06	23.98	24.13
		1	0	25.14	25.35	25.39	25.29	25.39	25.31	25.00	24.88	24.97	24.33	24.29	24.38
		1	2	25.21	25.42	25.47	25.36	25.42	25.34	25.07	24.96	24.93	24.24	24.29	24.40
		1	5	25.21	25.37	25.27	25.39	25.36	25.28	24.95	24.78	25.03	24.29	24.23	24.41
		3	0	25.14	25.36	25.32	25.31	25.29	25.23	24.95	24.80	24.84	24.12	24.11	24.35
		3	1	25.21	25.39	25.28	25.31	25.31	25.21	24.90	24.90	24.85	24.16	24.12	24.30
	64QAM	3	2	25.23	25.44	25.31	25.33	25.31	25.25	24.95	24.86	24.80	24.18	24.06	24.29
		6	0	24.09	24.29	24.22	24.28	24.22	24.16	23.86	23.75	23.79	23.00	23.00	23.16
		1	0	24.19	24.57	24.44	24.50	24.46	24.40	24.14	24.01	24.06	23.29	23.31	23.50
		1	2	24.30	24.62	24.54	24.63	24.48	24.41	24.14	24.06	24.09	23.34	23.42	23.45
		1	5	24.21	24.49	24.49	24.49	24.45	24.33	24.14	24.12	24.07	23.32	23.39	23.48
		3	0	24.29	24.40	24.32	24.35	24.45	24.29	23.96	23.92	23.91	23.18	23.19	23.37
	256QAM	3	1	24.26	24.36	24.28	24.36	24.44	24.35	23.97	23.93	23.87	23.22	23.19	23.42
		3	2	24.29	24.42	24.34	24.38	24.41	24.34	23.95	23.89	23.97	23.20	23.18	23.41
		6	0	23.25	23.26	23.18	23.21	23.31	23.23	22.87	22.75	22.86	22.02	22.20	22.34
		1	0	21.06	21.29	21.23	21.16	21.23	21.34	20.99	20.85	20.88	19.95	20.10	20.40
		1	2	21.08	21.35	21.30	21.24	21.39	21.31	20.97	20.98	20.96	20.06	20.21	20.43
		1	5	21.12	21.32	21.32	21.30	21.30	21.34	20.95	20.86	20.91	20.04	20.17	20.35

OUTPUT POWER FOR LTE BAND 66 (3.0 MHz)

Bandwidth (MHz)	Modulation	RB Allocation	RB Offset	Conducted Average (dBm)											
				ANT 1			ANT 2			ANT 3			ANT 4		
				131987	132322	132657	131987	132322	132657	131987	132322	132657	131987	132322	132657
3.0	QPSK	1	0	25.47	25.57	25.54	25.61	25.56	25.56	25.39	25.28	25.30	24.87	24.90	25.11
		1	7	25.55	25.70	25.65	25.70	25.69	25.65	25.50	25.40	25.40	25.02	25.00	25.20
		1	14	25.45	25.59	25.55	25.57	25.56	25.54	25.39	25.29	25.31	24.87	24.92	25.06
		8	0	25.15	25.21	25.25	25.24	25.16	25.18	24.85	24.80	24.77	24.02	23.87	24.20
		8	4	25.16	25.22	25.25	25.25	25.25	25.20	24.87	24.82	24.81	23.99	23.99	24.26
		8	7	25.18	25.32	25.23	25.27	25.28	25.22	24.89	24.80	24.82	24.03	23.97	24.13
	16QAM	15	0	25.14	25.20	25.20	25.23	25.24	25.18	24.86	24.79	24.77	24.02	23.93	24.14
		1	0	25.22	25.39	25.37	25.43	25.43	25.31	24.99	24.97	24.85	24.14	24.14	24.23
		1	7	25.38	25.44	25.47	25.47	25.47	25.43	25.07	24.95	24.99	24.18	24.10	24.30
		1	14	25.24	25.36	25.34	25.38	25.37	25.31	24.89	24.86	24.94	24.12	24.03	24.23
		8	0	24.18	24.21	24.25	24.29	24.16	24.22	23.84	23.84	23.81	23.01	22.92	23.20
		8	4	24.22	24.26	24.29	24.30	24.33	24.25	23.87	23.83	23.87	23.06	23.10	23.26
	64QAM	8	7	24.21	24.31	24.28	24.33	24.33	24.26	23.88	23.81	23.87	23.06	23.11	23.26
		15	0	24.11	24.19	24.24	24.26	24.25	24.20	23.84	23.77	23.81	23.04	23.04	23.25
		1	0	24.24	24.54	24.43	24.52	24.52	24.52	24.16	24.09	24.02	23.30	23.30	23.43
		1	7	24.35	24.46	24.47	24.60	24.64	24.56	24.22	24.10	24.10	23.43	23.39	23.49
		1	14	24.33	24.44	24.39	24.48	24.52	24.46	24.09	23.99	24.08	23.25	23.30	23.40
		8	0	23.20	23.21	23.28	23.26	23.29	23.21	22.93	22.85	22.87	22.07	21.96	22.22
	256QAM	8	4	23.26	23.25	23.29	23.29	23.37	23.25	22.95	22.88	22.90	22.10	22.05	22.30
		8	7	23.27	23.30	23.30	23.30	23.36	23.24	22.96	22.87	22.89	22.09	22.07	22.26
		15	0	23.16	23.22	23.23	23.31	23.31	23.23	22.89	22.81	22.81	22.05	22.07	22.22
		1	0	21.12	21.31	21.24	21.20	21.28	21.27	20.88	20.93	20.88	19.90	19.98	20.26
		1	7	21.20	21.43	21.35	21.34	21.46	21.26	20.99	20.97	20.93	20.15	20.16	20.26
		1	14	21.18	21.31	21.21	21.37	21.28	21.31	20.84	20.91	20.86	20.06	20.11	20.24

OUTPUT POWER FOR LTE BAND 66 (5.0 MHz)

Bandwidth (MHz)	Modulation	RB Allocation	RB Offset	Conducted Average (dBm)											
				ANT 1			ANT 2			ANT 3			ANT 4		
				131997	132322	132647	131997	132322	132647	131997	132322	132647	131997	132322	132647
5.0	QPSK	1	0	25.39	25.53	25.45	25.59	25.55	25.50	25.41	25.23	25.23	24.82	24.88	25.12
		1	12	25.59	25.70	25.61	25.70	25.61	25.60	25.50	25.38	25.35	24.97	25.02	25.20
		1	24	25.42	25.56	25.50	25.57	25.55	25.49	25.37	25.22	25.24	24.89	24.89	25.10
		12	0	25.11	25.15	25.14	25.21	25.08	25.10	24.82	24.71	24.70	23.90	23.84	24.21
		12	6	25.13	25.17	25.18	25.29	25.21	25.17	24.85	24.76	24.73	24.06	23.92	24.25
		12	11	25.11	25.20	25.16	25.20	25.21	25.12	24.83	24.71	24.70	24.03	23.90	24.21
		25	0	25.10	25.15	25.14	25.21	25.18	25.15	24.81	24.70	24.71	23.91	24.04	24.15
	16QAM	1	0	25.26	25.34	25.29	25.30	25.39	25.36	24.89	24.94	24.88	24.13	24.03	24.30
		1	12	25.32	25.41	25.44	25.44	25.50	25.46	25.02	25.01	24.95	24.16	24.20	24.46
		1	24	25.24	25.39	25.34	25.47	25.41	25.30	24.98	24.86	24.91	24.09	24.17	24.34
		12	0	24.06	24.24	24.10	24.17	24.00	24.11	23.90	23.63	23.72	22.84	22.98	23.24
		12	6	24.08	24.27	24.15	24.19	24.11	24.14	23.93	23.65	23.76	22.97	23.06	23.29
		12	11	24.05	24.30	24.13	24.18	24.06	24.11	23.90	23.64	23.71	22.95	23.04	23.24
		25	0	24.08	24.13	24.15	24.26	24.19	24.12	23.82	23.71	23.71	23.02	23.02	23.24
	64QAM	1	0	24.23	24.40	24.38	24.45	24.41	24.37	24.01	23.87	23.94	23.24	23.27	23.51
		1	12	24.37	24.52	24.47	24.55	24.45	24.46	24.12	23.98	23.94	23.36	23.37	23.50
		1	24	24.37	24.48	24.38	24.35	24.36	24.35	24.03	23.90	24.01	23.22	23.30	23.41
		12	0	23.11	23.18	23.20	23.31	23.11	23.16	22.91	22.79	22.74	21.90	21.92	22.34
		12	6	23.09	23.22	23.25	23.36	23.22	23.18	22.91	22.81	22.79	22.02	22.06	22.38
		12	11	23.07	23.29	23.21	23.33	23.22	23.16	22.87	22.79	22.74	21.97	22.00	22.32
		25	0	23.06	23.11	23.13	23.21	23.20	23.18	22.86	22.72	22.71	22.03	22.04	22.25
	256QAM	1	0	21.08	21.26	21.24	21.19	21.11	21.13	20.90	20.83	20.84	20.02	19.99	20.28
		1	12	21.19	21.40	21.36	21.31	21.39	21.25	20.99	20.85	20.85	20.24	20.12	20.36
		1	24	21.13	21.31	21.27	21.38	21.26	21.19	20.92	20.80	20.83	20.18	20.05	20.30
		12	0	21.03	21.12	21.09	21.21	21.07	21.14	20.77	20.70	20.70	19.91	19.97	20.24
12		6	21.07	21.14	21.11	21.25	21.19	21.19	20.81	20.73	20.74	20.03	20.08	20.27	
12		11	21.04	21.21	21.11	21.24	21.15	21.14	20.81	20.68	20.70	20.02	20.06	20.23	
25		0	21.05	21.10	21.07	21.23	21.14	21.19	20.79	20.70	20.70	19.99	20.03	20.21	

OUTPUT POWER FOR LTE BAND 66 (10.0 MHz)

Bandwidth (MHz)	Modulation	RB Allocation	RB Offset	Conducted Average (dBm)											
				ANT 1			ANT 2			ANT 3			ANT 4		
				132022	132322	132622	132022	132322	132622	132022	132322	132622	132022	132322	132622
10.0	QPSK	1	0	25.50	25.64	25.63	25.63	25.61	25.60	25.45	25.36	25.40	25.09	25.11	21.72
		1	24	25.54	25.70	25.61	25.70	25.66	25.66	25.50	25.42	25.42	25.18	25.20	21.66
		1	49	25.53	25.65	25.59	25.62	25.60	25.56	25.44	25.35	25.39	25.08	25.08	21.39
		25	0	25.09	25.22	25.24	25.26	25.16	25.15	24.93	24.75	24.84	24.13	24.13	20.48
		25	12	25.22	25.26	25.29	25.32	25.20	25.18	24.95	24.87	24.87	24.19	24.25	20.56
		25	24	25.19	25.32	25.26	25.29	25.27	25.22	24.92	24.83	24.86	24.11	24.22	20.54
		50	0	25.19	25.23	25.26	25.28	25.22	25.13	24.90	24.75	24.83	24.21	24.24	20.40
	16QAM	1	0	25.26	25.40	25.38	25.38	25.41	25.35	25.04	24.96	24.99	24.20	24.27	20.70
		1	24	25.27	25.39	25.41	25.42	25.45	25.36	25.04	24.98	24.97	24.37	24.38	20.72
		1	49	25.22	25.42	25.35	25.37	25.44	25.40	25.03	24.97	24.95	24.31	24.28	20.71
		25	0	24.11	24.25	24.24	24.28	24.19	24.13	23.93	23.77	23.84	23.14	23.17	19.45
		25	12	24.19	24.27	24.28	24.30	24.24	24.17	23.94	23.86	23.88	23.21	23.25	19.27
		25	24	24.19	24.31	24.25	24.27	24.28	24.20	23.91	23.85	23.87	23.20	23.25	19.22
		50	0	24.15	24.23	24.26	24.27	24.19	24.14	23.91	23.77	23.83	23.21	23.24	19.45
	64QAM	1	0	24.43	24.50	24.44	24.52	24.50	24.51	24.13	24.02	24.08	23.48	23.58	19.72
		1	24	24.46	24.56	24.47	24.51	24.56	24.54	24.11	24.10	24.10	23.58	23.58	19.70
		1	49	24.41	24.57	24.46	24.47	24.50	24.42	24.17	24.09	24.08	23.51	23.49	19.62
		25	0	23.09	23.25	23.23	23.27	23.21	23.15	22.93	22.75	22.84	22.19	22.17	18.64
		25	12	23.21	23.26	23.25	23.30	23.24	23.19	22.95	22.88	22.86	22.29	18.69	18.72
		25	24	23.17	23.32	23.25	23.26	23.31	23.23	22.91	22.84	22.86	22.25	18.65	18.60
		50	0	23.18	23.23	23.25	23.26	23.20	23.16	22.92	22.75	22.88	22.25	18.70	18.51
	256QAM	1	0	21.17	21.26	21.36	21.18	21.23	21.18	20.99	20.88	20.90	20.24	16.52	16.54
		1	24	21.29	21.42	21.39	21.38	21.33	21.34	21.11	20.98	20.93	20.37	16.66	16.72
		1	49	21.22	21.36	21.35	21.32	21.25	21.22	21.05	20.87	20.88	20.32	16.66	16.69
		25	0	21.07	21.18	21.23	21.26	21.22	21.15	20.92	20.72	20.84	20.17	16.60	16.58
25		12	21.16	21.24	21.26	21.30	21.24	21.16	20.94	20.84	20.86	20.29	16.72	16.72	
25		24	21.13	21.29	21.21	21.25	21.29	21.20	20.91	20.81	20.84	20.26	16.67	16.65	
50		0	21.15	21.21	21.21	21.24	21.21	21.14	20.89	20.77	20.83	20.27	16.70	16.56	

OUTPUT POWER FOR LTE BAND 66 (15.0 MHz)

Bandwidth (MHz)	Modulation	RB Allocation	RB Offset	Conducted Average (dBm)											
				ANT 1			ANT 2			ANT 3			ANT 4		
				132047	132322	132597	132047	132322	132597	132047	132322	132597	132047	132322	132597
15.0	QPSK	1	0	25.32	25.43	25.46	25.63	25.51	25.55	25.47	25.35	25.35	25.20	25.20	25.20
		1	37	25.39	25.48	25.43	25.62	25.50	25.53	25.46	25.38	25.39	24.85	24.90	25.13
		1	74	25.42	25.54	25.37	25.70	25.47	25.40	25.50	25.45	25.38	25.00	24.73	24.71
		36	0	24.12	24.25	24.26	25.28	25.07	25.07	24.96	24.81	24.78	24.12	23.93	24.20
		36	16	24.20	24.28	24.25	25.25	25.14	25.05	24.95	24.88	24.77	23.92	23.89	24.09
		36	35	24.21	24.34	24.23	25.12	25.12	25.11	24.92	24.86	24.85	23.79	23.86	23.96
		75	0	24.20	24.23	24.25	25.12	25.12	25.04	24.95	24.77	24.76	23.81	23.88	23.89
	16QAM	1	0	24.43	24.53	24.42	25.29	25.26	25.29	25.08	25.04	25.01	24.19	24.20	24.18
		1	37	24.50	24.57	24.49	25.20	25.23	25.32	25.12	25.10	25.05	24.20	24.02	24.14
		1	74	24.43	24.58	24.40	25.18	25.23	25.19	25.07	25.05	25.00	24.16	24.14	24.04
		36	0	23.15	23.25	23.25	24.18	24.08	24.08	23.98	23.81	23.79	23.14	23.00	23.02
		36	16	23.22	23.25	23.24	24.20	24.15	24.06	23.95	23.88	23.81	23.14	22.90	23.14
		36	35	23.22	23.32	23.22	24.24	24.13	24.11	23.93	23.86	23.86	23.14	22.90	23.12
		75	0	23.21	23.24	23.23	24.25	24.15	24.07	23.92	23.81	23.77	23.14	22.70	23.13
	64QAM	1	0	21.26	21.36	21.30	24.53	24.45	24.38	24.17	24.01	24.04	23.20	23.20	23.20
		1	37	21.34	21.38	21.28	24.55	24.46	24.36	24.17	24.19	24.14	23.03	22.96	23.14
		1	74	21.34	21.45	21.32	24.54	24.50	24.23	24.21	24.13	24.06	22.83	22.96	22.95
		36	0	21.09	21.19	21.22	23.28	23.07	23.12	22.99	22.77	22.79	22.19	22.20	22.16
		36	16	21.17	21.21	21.21	23.26	23.13	23.09	22.96	22.87	22.78	22.15	22.17	22.20
		36	35	21.17	21.30	21.19	23.23	23.13	23.15	22.96	22.87	22.85	22.20	22.16	22.17
		75	0	21.16	21.21	21.23	23.24	23.14	23.08	22.94	22.77	22.78	22.16	22.18	22.19
	256QAM	1	0	25.63	25.59	25.55	21.25	21.09	21.09	21.04	20.98	20.86	20.08	20.09	20.07
		1	37	25.65	25.58	25.51	21.25	21.23	21.20	21.02	20.99	20.93	20.16	20.10	20.18
		1	74	25.70	25.50	25.57	21.26	21.24	21.22	21.08	20.98	20.95	20.08	20.15	20.16
		36	0	25.25	25.25	25.14	21.25	21.05	21.08	20.95	20.77	20.77	20.20	20.16	20.18
		36	16	25.26	25.25	25.24	21.24	21.13	21.06	20.93	20.85	20.77	20.13	20.12	20.13
		36	35	25.32	25.23	25.22	21.19	21.11	21.12	20.91	20.84	20.83	20.09	20.10	20.20
		75	0	25.25	25.25	25.21	21.24	21.11	21.07	20.92	20.76	20.75	20.11	20.20	20.16

OUTPUT POWER FOR LTE BAND 66 (20.0 MHz)

Bandwidth (MHz)	Modulation	RB Allocation	RB Offset	Conducted Average (dBm)											
				ANT 1			ANT 2			ANT 3			ANT 4		
				132072	132322	132572	132072	132322	132572	132072	132322	132572	132072	132322	132572
20.0	QPSK	1	0	25.59	25.69	25.62	25.70	25.60	25.48	25.50	25.45	25.41	25.20	25.20	25.20
		1	49	25.55	25.70	25.58	25.62	25.56	25.48	25.49	25.41	25.33	24.79	24.81	24.90
		1	99	25.61	25.70	25.60	25.65	25.57	25.44	25.48	25.50	25.35	24.72	24.75	24.97
		50	0	25.18	25.32	25.30	25.22	25.13	25.08	24.97	24.82	24.80	23.85	23.93	23.90
		50	24	25.28	25.32	25.31	25.30	25.19	25.17	24.96	24.84	24.81	23.83	23.94	23.97
		50	49	25.26	25.31	25.28	25.24	25.16	25.14	24.93	24.89	24.79	23.79	23.82	23.91
		100	0	25.25	25.30	25.30	25.29	25.17	25.13	24.92	24.82	24.78	23.81	23.83	23.90
	16QAM	1	0	25.46	25.41	25.37	25.42	25.16	25.28	25.05	24.93	24.94	24.20	24.20	24.11
		1	49	25.52	25.58	25.56	25.36	25.23	25.38	25.24	25.17	25.17	24.05	24.12	24.20
		1	99	25.46	25.45	25.36	25.37	25.12	25.19	25.02	24.98	24.95	24.03	24.07	23.92
		50	0	24.19	24.30	24.31	24.17	24.00	24.09	23.98	23.81	23.79	22.77	22.96	22.75
		50	24	24.29	24.31	24.30	24.30	24.18	24.17	23.97	23.80	23.79	22.85	23.02	22.98
		50	49	24.27	24.27	24.28	24.28	24.19	24.15	23.92	23.87	23.76	22.89	22.98	22.83
		100	0	24.27	24.30	24.28	24.29	24.17	24.18	23.93	23.79	23.77	22.91	22.98	22.75
	64QAM	1	0	24.46	24.46	24.50	24.49	24.45	24.38	24.33	24.13	23.98	23.20	23.20	23.20
		1	49	24.51	24.70	24.61	24.52	24.34	24.32	24.37	24.31	24.08	22.87	23.04	23.18
		1	99	24.49	24.54	24.41	24.43	24.34	24.29	24.23	24.12	24.12	22.92	22.99	22.90
		50	0	23.17	23.29	23.30	23.19	23.13	23.10	22.97	22.83	22.76	22.16	22.20	22.19
		50	24	23.28	23.28	23.30	23.27	23.20	23.16	22.97	22.83	22.79	22.20	22.10	22.20
		50	49	23.25	23.28	23.28	23.24	23.18	23.14	22.93	22.89	22.75	22.17	22.14	22.12
		100	0	23.26	23.28	23.29	23.26	23.18	23.15	22.93	22.81	22.77	22.13	22.10	22.06
	256QAM	1	0	21.20	21.42	21.47	21.31	21.31	21.27	20.98	20.89	20.87	20.09	20.20	20.06
		1	49	21.32	21.44	21.31	21.37	21.30	21.26	21.00	20.91	20.83	20.20	20.02	20.16
		1	99	21.42	21.37	21.34	21.34	21.33	21.29	21.01	20.98	20.94	20.15	20.17	20.20
		50	0	21.16	21.27	21.24	21.16	21.10	21.05	20.95	20.78	20.75	20.00	20.09	19.94
		50	24	21.23	21.28	21.27	21.25	21.17	21.13	20.95	20.78	20.77	19.97	20.11	20.14
		50	49	21.23	21.25	21.25	21.22	21.14	21.09	20.90	20.88	20.74	20.00	20.02	20.10
		100	0	21.22	21.26	21.25	21.24	21.14	21.13	20.91	20.78	20.74	20.06	20.14	20.13

5G NR n66

Test Engineer ID:	32061	Test Date:	2024-02-23
-------------------	-------	------------	------------

OUTPUT POWER FOR 5G NR n66 (5.0 MHz)

Bandwidth (MHz)	Modulation	RB Allocation	RB Offset	Conducted Average (dBm)											
				ANT 1			ANT 2			ANT 3			ANT 4		
				342500	349000	355500	342500	349000	355500	342500	349000	355500	342500	349000	355500
5.0	BPSK	1	0	25.15	25.58	25.54	25.56	25.59	25.58	25.22	25.34	25.37	25.04	25.04	24.99
		1	1	25.28	25.55	25.46	25.60	25.60	25.53	25.28	25.20	25.44	25.11	25.01	24.85
		1	23	25.22	25.63	25.47	25.54	25.67	25.44	25.22	25.36	25.39	25.03	25.06	24.88
		1	24	25.34	25.54	25.53	25.53	25.70	25.49	25.33	25.34	25.38	25.05	25.04	24.92
		12	6	25.45	25.57	25.52	25.56	25.66	25.54	25.34	25.38	25.44	25.07	25.07	24.91
	25	0	25.35	25.47	25.42	25.52	25.56	25.46	25.31	25.21	25.37	25.06	24.96	24.87	
	QPSK	1	0	25.09	25.32	25.10	25.11	25.14	25.16	24.49	24.91	25.07	24.79	24.59	24.55
		1	1	25.60	25.49	25.70	25.51	25.62	25.54	25.36	25.33	25.50	25.20	25.05	24.92
		1	23	25.54	25.55	25.61	25.60	25.63	25.47	25.39	25.36	25.46	25.16	25.00	24.90
		1	24	25.04	25.15	25.22	25.22	25.21	25.04	24.40	24.79	25.01	24.71	24.57	24.59
		12	6	25.50	25.54	25.46	25.68	25.61	25.59	25.17	25.29	25.41	25.15	25.04	24.93
	25	0	25.07	25.10	25.10	25.18	25.21	25.07	24.22	24.90	25.00	24.71	24.52	24.51	
	16QAM	1	0	24.24	23.85	24.20	24.13	24.14	24.03	23.55	23.73	24.16	23.48	23.52	23.63
		1	1	25.01	25.24	25.06	25.01	25.41	25.21	24.39	24.89	24.99	24.71	24.47	24.79
		1	23	25.27	25.09	25.49	25.38	25.25	25.07	24.44	24.91	24.87	24.66	24.89	24.58
		1	24	23.95	24.41	24.19	24.20	24.05	24.29	23.50	23.78	23.73	23.62	23.54	23.87
		12	6	25.07	25.11	25.01	25.16	25.19	25.17	24.44	24.81	24.90	24.67	24.62	24.48
	25	0	24.12	24.08	24.04	24.15	24.19	24.13	23.34	23.90	23.91	23.78	23.62	23.48	
	64QAM	1	0	23.85	23.73	23.54	23.79	23.78	23.97	23.24	23.43	23.65	23.46	23.82	23.24
		1	1	23.62	23.73	23.73	23.66	23.81	23.93	23.11	23.45	23.51	23.31	23.31	23.13
		1	23	23.72	23.76	23.51	24.02	23.65	23.63	22.92	23.30	23.58	23.39	23.01	23.46
		1	24	23.79	23.83	23.56	23.70	23.67	23.88	22.72	23.51	23.18	23.32	23.26	23.21
		12	6	23.50	23.66	23.45	23.63	23.66	23.61	22.97	23.32	23.42	23.23	23.15	22.98
	25	0	23.62	23.67	23.60	23.75	23.73	23.79	23.03	23.44	23.49	23.34	23.15	23.12	
	256QAM	1	0	21.68	21.56	21.68	21.63	21.72	21.64	21.73	21.38	21.54	21.32	21.25	21.20
		1	1	21.51	21.68	21.47	21.90	21.57	21.62	21.56	21.48	21.49	21.35	21.07	21.25
		1	23	21.58	21.51	21.61	21.80	21.69	21.67	21.67	21.58	21.37	21.36	21.07	21.11
		1	24	21.56	21.67	21.48	21.87	21.85	21.68	21.48	21.31	21.35	21.27	21.33	21.36
		12	6	21.61	21.73	21.59	21.76	21.72	21.73	21.55	21.43	21.49	21.33	21.10	21.15
	25	0	21.56	21.65	21.63	21.78	21.66	21.63	21.42	21.37	21.40	21.24	21.06	21.10	

OUTPUT POWER FOR 5G NR n66 (10.0 MHz)

Bandwidth (MHz)	Modulation	RB Allocation	RB Offset	Conducted Average (dBm)											
				ANT 1			ANT 2			ANT 3			ANT 4		
				343000	349000	355000	343000	349000	355000	343000	349000	355000	343000	349000	355000
10.0	BPSK	1	0	25.55	25.63	25.70	25.51	25.54	25.54	25.40	25.27	25.47	24.99	25.00	24.88
		1	1	25.51	25.66	25.64	25.59	25.60	25.52	25.41	25.20	25.46	25.07	24.90	24.95
		1	50	25.56	25.64	25.59	25.53	25.53	25.43	25.35	25.17	25.46	25.07	24.95	24.84
		1	51	25.49	25.55	25.55	25.59	25.49	25.46	25.32	25.30	25.40	25.05	24.97	24.78
		25	12	25.56	25.65	25.54	25.57	25.56	25.55	25.34	25.22	25.43	25.14	25.00	24.88
	50	0	25.50	25.62	25.58	25.70	25.57	25.60	25.40	25.27	25.50	25.15	25.05	24.96	
	QPSK	1	0	25.17	25.21	25.21	25.31	25.20	25.30	24.51	24.81	25.02	24.87	24.65	24.55
		1	1	25.58	25.60	25.59	25.65	25.56	25.56	25.47	25.27	25.50	25.12	24.96	24.91
		1	50	25.53	25.53	25.63	25.62	25.54	25.59	25.28	25.31	25.42	25.13	25.20	24.87
		1	51	25.21	25.17	25.23	25.17	25.18	25.09	24.57	24.88	25.04	24.68	24.52	24.42
		25	12	25.66	25.63	25.57	25.66	25.56	25.60	25.27	25.30	25.47	25.17	25.07	24.96
	50	0	25.19	25.26	25.25	25.28	25.15	25.17	24.15	24.92	25.05	24.72	24.61	24.54	
	16QAM	1	0	24.22	24.04	24.58	24.32	24.48	24.22	23.53	23.56	24.00	23.83	23.65	23.40
		1	1	25.25	25.39	25.04	25.14	25.20	25.17	24.53	24.77	24.70	24.72	24.64	25.03
		1	50	25.11	25.06	25.25	25.21	25.39	25.06	24.47	24.87	25.22	24.32	24.60	24.71
		1	51	24.73	24.02	24.18	24.16	24.08	23.86	23.44	24.00	23.90	23.81	23.49	23.33
		25	12	25.24	25.20	25.12	25.23	25.15	25.22	24.31	24.88	24.98	24.80	24.69	24.66
	50	0	24.33	24.26	24.15	24.25	24.32	24.14	23.30	23.92	24.01	23.75	23.61	23.62	
	64QAM	1	0	23.81	24.05	23.83	23.92	23.75	23.68	23.21	23.43	23.27	23.40	23.21	23.18
		1	1	23.77	23.72	23.66	24.02	23.42	23.93	23.01	23.50	23.46	23.27	23.14	23.22
		1	50	23.90	23.74	23.86	23.76	23.76	23.82	23.10	23.43	23.51	23.16	22.96	22.99
		1	51	23.80	23.84	23.77	23.93	23.48	24.02	23.00	23.18	23.33	23.55	23.10	23.30
		25	12	23.91	23.81	23.71	23.81	23.82	23.81	22.92	23.55	23.47	23.33	23.21	23.20
	50	0	23.87	23.85	23.73	23.76	23.78	23.78	22.85	23.52	23.54	23.35	23.15	23.23	
	256QAM	1	0	21.80	21.83	21.65	21.66	21.90	21.74	21.41	21.58	21.42	21.37	21.22	21.38
		1	1	21.64	21.78	21.76	21.88	21.86	21.77	21.54	21.54	21.30	21.23	21.09	21.16
		1	50	21.88	21.83	21.72	21.77	21.72	21.84	21.46	21.33	21.39	21.14	21.00	21.06
		1	51	21.44	21.93	21.56	21.88	21.72	21.71	21.20	21.50	21.43	21.43	21.24	21.39
		25	12	21.64	21.80	21.67	21.79	21.72	21.65	21.33	21.50	21.49	21.25	21.15	21.25
	50	0	21.76	21.81	21.61	21.79	21.71	21.70	21.34	21.43	21.43	21.22	21.09	21.20	

OUTPUT POWER FOR 5G NR n66 (15.0 MHz)

Bandwidth (MHz)	Modulation	RB Allocation	RB Offset	Conducted Average (dBm)											
				ANT 1			ANT 2			ANT 3			ANT 4		
				343500	349000	354500	343500	349000	354500	343500	349000	354500	343500	349000	354500
15.0	BPSK	1	0	25.50	25.52	25.50	25.54	25.52	25.34	25.36	25.37	25.45	25.13	24.83	24.77
		1	1	25.48	25.49	25.60	25.52	25.46	25.49	25.37	25.31	25.42	25.20	24.85	24.73
		1	77	25.52	25.48	25.49	25.49	25.56	25.34	25.34	25.39	25.39	25.08	24.69	24.71
		1	78	25.48	25.50	25.44	25.52	25.52	25.35	25.28	25.43	25.43	25.09	24.74	24.61
		36	18	25.32	25.33	25.36	25.32	25.41	25.28	25.23	25.18	25.35	24.97	24.67	24.53
		75	0	25.40	25.40	25.40	25.48	25.38	25.36	25.30	25.26	25.37	25.06	24.71	24.62
	QPSK	1	0	25.10	25.12	25.14	25.05	25.06	25.03	24.46	24.92	24.96	24.75	24.43	24.28
		1	1	25.59	25.47	25.57	25.53	25.60	25.47	25.46	25.47	25.43	25.15	24.87	24.81
		1	77	25.70	25.45	25.52	25.70	25.40	25.44	25.36	25.36	25.50	25.04	24.83	24.80
		1	78	25.22	25.02	25.01	25.19	24.82	24.96	24.65	25.05	25.05	24.74	24.40	24.21
		36	18	25.45	25.42	25.41	25.37	25.38	25.32	25.20	25.23	25.38	25.00	24.66	24.68
		75	0	25.04	25.12	25.02	24.99	24.83	24.98	24.29	24.87	25.01	24.63	24.32	24.37
	16QAM	1	0	24.20	24.16	24.24	24.17	24.06	23.96	23.66	24.11	23.88	23.88	23.60	23.15
		1	1	25.19	25.58	25.28	25.09	25.16	25.08	24.34	24.90	25.15	24.86	24.60	24.37
		1	77	25.06	25.12	24.95	24.89	24.76	25.32	24.60	25.02	24.90	24.91	24.45	24.32
		1	78	24.05	24.05	23.76	24.25	23.73	24.37	23.45	24.10	24.00	23.68	23.20	23.60
		36	18	25.08	25.11	24.98	24.91	24.73	24.96	24.32	24.84	24.93	24.64	24.37	24.44
		75	0	24.10	24.10	24.05	24.06	24.00	23.99	23.48	23.87	23.95	23.66	23.35	23.44
	64QAM	1	0	23.69	23.70	23.50	23.71	23.61	23.32	23.12	23.48	23.50	23.30	23.03	23.23
		1	1	23.76	23.79	23.69	23.69	23.91	23.68	22.97	23.49	23.64	23.29	23.20	22.94
		1	77	23.81	23.64	23.41	23.68	23.63	23.39	23.31	23.53	23.50	23.30	22.83	23.01
		1	78	23.60	23.49	23.46	23.37	23.59	23.50	23.03	23.48	23.81	23.39	23.10	23.00
		36	18	23.63	23.62	23.55	23.67	23.58	23.48	22.93	23.36	23.50	23.15	22.84	22.99
		75	0	23.54	23.61	23.46	23.52	23.52	23.47	22.99	23.35	23.47	23.13	22.85	22.97
	256QAM	1	0	21.52	21.30	21.55	21.65	21.68	21.39	21.70	21.34	21.55	21.25	20.93	21.03
		1	1	21.73	21.58	21.43	21.74	21.57	21.79	21.54	21.73	21.61	21.19	20.93	21.07
		1	77	21.51	21.46	21.47	21.66	21.48	21.64	21.65	21.64	21.31	21.13	20.80	20.81
		1	78	21.44	21.66	21.46	21.72	21.61	21.60	21.44	21.55	21.39	21.05	20.66	21.11
		36	18	21.53	21.59	21.41	21.59	21.56	21.57	21.37	21.36	21.39	21.10	20.87	20.91
		75	0	21.49	21.58	21.41	21.57	21.61	21.55	21.38	21.38	21.36	21.09	20.84	20.91

OUTPUT POWER FOR 5G NR n66 (20.0 MHz)

Bandwidth (MHz)	Modulation	RB Allocation	RB Offset	Conducted Average (dBm)											
				ANT 1			ANT 2			ANT 3			ANT 4		
				344000	349000	354000	344000	349000	354000	344000	349000	354000	344000	349000	354000
20.0	BPSK	1	0	25.47	25.54	25.49	25.36	25.56	25.53	25.33	25.39	25.38	25.19	24.89	24.86
		1	1	25.49	25.52	25.43	25.43	25.46	25.56	25.35	25.37	25.45	25.08	24.89	24.71
		1	104	25.52	25.52	25.38	25.42	25.44	25.50	25.41	25.36	25.42	25.06	24.79	24.72
		1	105	25.55	25.51	25.41	25.37	25.35	25.42	25.38	25.42	25.44	25.05	24.79	24.66
		50	25	25.44	25.55	25.40	25.24	25.43	25.47	25.29	25.31	25.37	24.99	24.86	24.72
		100	0	25.46	25.46	25.43	25.39	25.45	25.48	25.28	25.32	25.37	24.97	24.85	24.74
	QPSK	1	0	25.01	25.18	25.01	25.00	25.01	25.21	24.34	24.92	25.04	24.68	24.43	24.36
		1	1	25.50	25.61	25.42	25.54	25.35	25.70	25.36	25.34	25.36	25.03	24.85	24.86
		1	104	25.51	25.70	25.48	25.38	25.41	25.43	25.50	25.38	25.32	25.01	24.79	24.70
		1	105	25.20	25.10	25.09	25.01	24.91	25.13	24.93	24.95	24.89	24.60	24.42	24.41
		50	25	25.43	25.47	25.41	25.36	25.42	25.52	25.33	25.31	25.37	24.99	24.80	24.81
		100	0	25.07	25.06	24.93	25.05	25.09	25.15	24.34	24.93	24.80	24.58	24.46	24.42
	16QAM	1	0	24.07	24.22	23.98	24.02	24.35	24.12	23.42	24.08	23.92	23.77	23.12	23.14
		1	1	25.16	25.37	25.22	25.10	25.67	25.14	24.29	24.80	24.74	25.20	24.60	24.70
		1	104	24.94	25.20	24.98	24.69	25.14	25.17	24.97	24.96	24.83	24.81	24.39	24.64
		1	105	24.23	24.03	23.74	23.75	24.31	24.22	24.01	24.12	23.88	23.58	23.49	23.57
		50	25	25.00	25.09	25.03	25.08	25.19	25.21	24.46	24.90	24.92	24.56	24.45	24.41
		100	0	24.03	24.11	24.05	24.10	24.20	24.24	23.55	23.98	23.98	23.68	23.54	23.45
	64QAM	1	0	23.47	23.72	23.58	23.33	23.80	23.77	23.17	23.42	23.46	23.30	23.05	23.12
		1	1	23.65	23.65	23.78	23.79	23.48	23.56	22.89	23.79	23.41	23.22	23.15	23.18
		1	104	23.62	23.36	23.64	23.74	23.93	23.67	23.45	23.60	23.31	23.22	22.68	23.31
		1	105	24.01	23.65	23.44	23.86	23.71	23.60	23.44	23.53	23.37	23.10	22.93	22.72
		50	25	23.53	23.56	23.52	23.53	23.73	23.71	23.03	23.44	23.48	23.17	22.92	22.95
		100	0	23.58	23.54	23.50	23.60	23.67	23.73	23.08	23.47	23.50	23.13	22.98	22.99
	256QAM	1	0	21.50	21.43	21.60	21.78	21.76	21.59	21.52	21.49	21.66	21.10	20.92	21.05
		1	1	21.64	21.53	21.47	21.54	21.74	21.67	21.65	21.65	21.49	21.49	20.86	21.10
		1	104	21.73	21.74	21.43	21.67	21.81	21.48	21.52	21.56	21.13	21.10	20.90	21.12
		1	105	21.63	21.45	21.44	21.68	21.80	21.76	21.23	21.64	21.53	21.03	21.02	21.00
		50	25	21.51	21.58	21.49	21.51	21.61	21.58	21.35	21.35	21.46	21.09	20.88	20.96
		100	0	21.56	21.47	21.47	21.64	21.53	21.65	21.43	21.37	21.49	21.09	20.90	20.84

OUTPUT POWER FOR 5G NR n66 (25.0 MHz)

Bandwidth (MHz)	Modulation	RB Allocation	RB Offset	Conducted Average (dBm)												
				ANT 1			ANT 2			ANT 3			ANT 4			
				344500	349000	353500	344500	349000	353500	344500	349000	353500	344500	349000	353500	
25.0	BPSK	1	0	25.58	25.69	25.65	25.51	25.65	25.58	25.58	25.50	25.33	25.42	25.15	25.01	24.97
		1	1	25.54	25.65	25.60	25.51	25.58	25.44	25.47	25.35	25.44	25.14	24.95	24.94	
		1	104	25.60	25.51	25.55	25.52	25.49	25.34	25.30	25.35	25.45	25.07	24.85	24.76	
		1	105	25.48	25.54	25.46	25.46	25.42	25.35	25.42	25.44	25.33	24.91	24.90	24.83	
		50	25	25.35	25.54	25.46	25.49	25.42	25.34	25.30	25.25	25.28	24.93	24.84	24.69	
	100	0	25.43	25.59	25.46	25.49	25.47	25.36	25.26	25.27	25.28	24.95	24.80	24.75		
	QPSK	1	0	24.95	25.22	25.18	25.26	25.18	25.06	24.33	24.96	25.03	24.73	24.59	24.55	
		1	1	25.62	25.69	25.70	25.58	25.70	25.68	25.34	25.44	25.44	25.20	24.97	24.95	
		1	104	25.49	25.67	25.51	25.58	25.64	25.52	25.37	25.37	25.34	24.78	24.93	24.73	
		1	105	25.08	25.16	25.09	25.08	24.91	25.04	24.92	25.01	24.97	24.53	24.52	24.45	
		50	25	25.35	25.58	25.45	25.52	25.43	25.34	25.30	25.28	25.22	24.90	24.84	24.86	
	100	0	24.94	25.20	25.09	25.13	24.99	24.94	24.46	24.92	24.87	24.52	24.42	24.51		
	16QAM	1	0	24.19	24.29	24.05	24.26	24.13	24.14	23.25	23.85	23.95	23.81	23.61	23.64	
		1	1	25.00	25.23	25.14	25.20	25.27	25.03	24.13	25.10	24.80	24.81	24.61	24.53	
		1	104	24.94	25.00	24.91	24.95	24.86	24.86	25.39	25.37	24.88	24.59	24.50	24.55	
		1	105	24.47	24.53	23.96	23.87	24.12	24.07	23.85	24.21	23.99	23.63	23.57	23.15	
		50	25	24.97	25.19	25.05	25.12	24.93	25.05	24.49	24.86	24.77	24.51	24.48	24.48	
	100	0	23.97	24.18	24.07	24.05	24.04	24.12	23.66	23.91	23.96	23.53	23.47	23.53		
	64QAM	1	0	23.42	23.86	23.74	23.76	23.67	23.68	22.66	23.69	23.65	23.31	23.07	23.09	
		1	1	23.78	23.77	23.89	23.92	23.78	23.54	22.60	23.39	23.45	23.16	23.29	23.38	
		1	104	23.65	23.70	23.71	23.93	23.41	23.61	23.61	23.55	23.35	23.08	23.14	22.76	
		1	105	23.63	23.55	23.78	23.98	23.67	23.43	23.39	23.55	23.53	23.35	22.86	23.10	
		50	25	23.40	23.63	23.49	23.58	23.50	23.52	23.05	23.38	23.45	23.00	22.92	23.02	
	100	0	23.53	23.64	23.53	23.63	23.53	23.53	23.12	23.43	23.47	23.11	22.96	23.02		
	256QAM	1	0	21.58	21.50	21.80	21.47	21.67	21.32	21.18	21.57	21.43	21.16	21.28	21.15	
		1	1	21.64	21.80	21.68	21.39	21.53	21.65	21.34	21.28	21.62	20.90	21.07	20.93	
		1	104	21.63	21.64	21.52	21.66	21.82	21.59	21.41	21.24	21.54	20.69	20.83	20.86	
		1	105	21.58	21.61	21.55	21.45	21.45	21.39	21.14	21.59	21.48	21.15	20.73	21.27	
		50	25	21.49	21.58	21.46	21.50	21.56	21.49	21.27	21.33	21.40	21.03	20.97	21.00	
	100	0	21.52	21.47	21.54	21.49	21.57	21.48	21.29	21.32	21.41	21.06	20.86	20.94		

OUTPUT POWER FOR 5G NR n66 (30.0 MHz)

Bandwidth (MHz)	Modulation	RB Allocation	RB Offset	Conducted Average (dBm)											
				ANT 1			ANT 2			ANT 3			ANT 4		
				345000	349000	353000	345000	349000	353000	345000	349000	353000	345000	349000	353000
30.0	BPSK	1	0	25.67	25.64	25.51	25.51	25.44	25.42	25.39	25.26	25.32	25.06	25.06	24.88
		1	1	25.64	25.52	25.52	25.59	25.57	25.48	25.42	25.28	25.42	25.10	25.00	24.82
		1	158	25.65	25.51	25.33	25.41	25.34	25.30	25.39	25.32	25.44	25.12	24.93	24.72
		1	159	25.63	25.59	25.39	25.37	25.35	25.36	25.39	25.35	25.34	24.96	24.86	24.90
		80	40	25.57	25.61	25.46	25.46	25.54	25.51	25.33	25.32	25.47	25.05	24.94	24.92
		160	0	25.66	25.67	25.51	25.49	25.56	25.47	25.36	25.36	25.50	25.13	25.01	24.98
	QPSK	1	0	25.14	25.23	24.97	25.24	25.13	25.01	24.26	24.86	24.97	24.69	24.52	24.37
		1	1	25.70	25.58	25.45	25.43	25.70	25.34	25.37	25.16	25.47	25.20	24.94	24.87
		1	158	25.68	25.49	25.47	25.47	25.47	25.39	25.39	25.42	25.38	25.00	25.01	24.65
		1	159	25.29	25.14	24.98	25.09	25.05	24.81	24.95	24.94	24.97	24.52	24.56	24.39
		80	40	25.59	25.61	25.50	25.48	25.43	25.49	25.38	25.38	25.46	25.13	24.97	24.95
		160	0	25.18	25.26	25.21	25.16	25.13	25.15	24.93	24.99	25.01	24.86	24.60	24.55
	16QAM	1	0	24.08	23.98	24.24	23.97	24.09	24.19	23.27	23.65	24.08	23.75	23.88	23.27
		1	1	25.18	25.26	24.99	25.22	24.97	25.09	24.23	24.61	25.05	24.99	24.22	25.08
		1	158	24.65	24.79	25.08	25.27	24.88	24.80	25.03	24.95	25.30	24.50	24.41	24.28
		1	159	24.13	24.42	23.91	23.71	24.28	24.30	24.07	23.78	23.89	23.60	23.40	23.92
		80	40	25.24	25.20	25.21	25.11	25.15	25.08	24.86	24.93	24.97	24.73	24.67	24.56
		160	0	24.23	24.28	24.21	24.23	24.13	24.11	23.90	23.98	24.04	23.83	23.68	23.65
	64QAM	1	0	23.45	23.65	23.65	23.85	23.52	23.45	22.59	23.35	23.48	23.57	23.30	23.25
		1	1	23.85	23.68	23.60	23.67	23.77	23.67	22.81	23.30	23.49	23.50	23.46	23.13
		1	158	23.93	23.68	23.78	23.47	23.70	23.58	23.30	23.50	23.61	23.13	23.20	22.78
		1	159	23.51	23.98	23.60	23.76	23.65	23.57	23.62	23.16	23.65	22.87	23.20	23.25
		80	40	23.63	23.67	23.66	23.68	23.63	23.58	23.37	23.44	23.47	23.21	23.14	23.05
		160	0	23.73	23.82	23.71	23.72	23.70	23.64	23.48	23.47	23.56	23.33	23.19	23.09
	256QAM	1	0	21.74	21.74	21.73	21.90	21.58	21.60	21.14	21.21	21.55	21.25	21.29	21.09
		1	1	21.85	21.52	21.86	21.85	21.58	21.44	21.57	21.34	21.79	21.46	21.40	21.29
		1	158	21.96	21.30	21.67	21.81	21.60	21.50	21.53	21.33	21.47	21.49	20.95	21.18
		1	159	21.80	21.52	21.59	21.41	21.63	21.79	21.25	21.26	21.13	21.09	20.82	21.21
		80	40	21.59	21.72	21.63	21.66	21.60	21.49	21.37	21.36	21.39	21.20	21.07	21.08
	160	0	21.66	21.70	21.64	21.64	21.64	21.61	21.40	21.42	21.46	21.29	21.20	21.15	

OUTPUT POWER FOR 5G NR n66 (35.0 MHz)

Bandwidth (MHz)	Modulation	RB Allocation	RB Offset	Conducted Average (dBm)											
				ANT 1			ANT 2			ANT 3			ANT 4		
				345500	349000	352500	345500	349000	352500	4E+06	349000	352500	345500	349000	352500
35.0	BPSK	1	0	25.54	25.19	25.58	25.61	25.42	25.54	25.50	25.02	25.25	25.20	24.84	25.09
		1	1	25.48	25.24	25.70	25.61	25.38	25.65	25.31	25.03	25.21	25.14	24.92	24.87
		1	104	25.51	25.31	25.35	25.42	25.41	25.15	25.22	24.95	24.94	24.78	24.75	24.51
		1	105	25.50	25.24	25.36	25.42	25.32	25.18	25.22	24.95	24.84	24.39	24.75	24.62
		50	25	25.34	25.29	25.35	25.34	25.35	25.32	25.03	25.00	25.02	24.45	24.84	24.81
		100	0	25.40	25.31	25.40	25.43	25.47	25.42	25.13	25.03	25.09	24.05	24.78	24.77
	QPSK	1	0	24.96	24.84	25.30	24.85	25.02	25.18	23.85	24.33	24.83	23.27	24.48	24.55
		1	1	25.45	25.13	25.58	25.58	25.39	25.70	24.85	24.95	25.12	24.01	25.05	24.96
		1	104	25.56	25.17	25.44	25.36	25.21	25.23	25.21	25.14	24.90	23.32	24.79	24.74
		1	105	25.24	24.81	25.13	24.65	24.95	24.90	24.79	24.36	24.49	22.38	24.39	24.10
		50	25	25.43	25.34	25.43	25.37	25.41	25.34	25.08	25.10	25.09	23.53	24.85	24.86
		100	0	25.00	24.96	25.05	25.02	25.07	25.01	24.44	24.67	24.54	22.56	24.43	24.49
	16QAM	1	0	24.27	23.91	24.00	24.20	24.16	24.08	22.92	23.51	23.83	21.87	23.56	23.65
		1	1	24.56	25.11	25.24	25.05	24.86	25.00	24.22	24.60	24.54	22.68	24.38	24.63
		1	104	25.11	25.32	25.18	24.62	25.19	24.67	24.65	24.22	24.60	22.04	24.51	24.23
		1	105	24.17	23.61	24.06	23.78	23.93	23.96	24.12	23.64	23.40	20.75	23.23	23.59
		50	25	24.96	24.99	25.00	24.98	24.99	24.95	24.64	24.67	24.44	22.18	24.52	24.44
		100	0	24.02	23.98	24.10	24.03	24.06	23.98	23.55	23.66	23.68	21.16	23.52	23.52
	64QAM	1	0	23.40	23.36	23.94	23.34	23.57	23.67	22.52	23.11	23.46	20.87	23.05	22.90
		1	1	23.43	23.26	23.80	23.60	23.73	23.68	22.48	22.84	23.40	21.03	23.27	23.06
		1	104	23.76	23.79	23.60	23.62	23.45	23.10	23.23	22.95	23.44	20.43	23.04	22.68
		1	105	23.64	23.57	23.49	23.13	23.46	23.42	23.35	22.93	23.09	20.31	22.92	22.87
		50	25	23.48	23.38	23.55	23.54	23.46	23.42	23.02	23.12	23.09	20.60	23.00	23.00
		100	0	23.51	23.46	23.57	23.63	23.54	23.45	23.10	23.19	23.21	20.56	22.99	23.02
	256QAM	1	0	21.77	21.43	21.76	21.60	21.65	21.96	21.08	21.27	21.27	19.25	21.34	21.24
		1	1	21.76	21.47	21.56	21.84	21.58	21.63	20.70	21.32	21.29	19.28	21.02	21.40
		1	104	21.37	21.44	21.39	21.35	21.77	21.26	20.97	21.33	21.11	18.76	20.94	20.76
		1	105	21.52	21.49	21.56	21.76	21.70	21.66	21.04	21.22	21.14	18.70	20.83	20.69
		50	25	21.35	21.42	21.45	21.55	21.54	21.53	21.09	21.05	21.15	19.09	20.95	21.02
		100	0	21.41	21.39	21.48	21.54	21.58	21.54	21.09	21.08	21.17	19.07	20.94	20.93

OUTPUT POWER FOR 5G NR n66 (40.0 MHz)

Bandwidth (MHz)	Modulation	RB Allocation	RB Offset	Conducted Average (dBm)											
				ANT 1			ANT 2			ANT 3			ANT 4		
				346000	349000	352000	346000	349000	352000	346000	349000	352000	346000	349000	352000
40.0	BPSK	1	0	25.59	25.51	25.52	25.62	25.64	25.31	25.32	25.36	25.34	25.06	25.07	25.01
		1	1	25.56	25.42	25.70	25.62	25.63	25.56	25.38	25.38	25.38	25.16	25.09	24.86
		1	214	25.54	25.48	25.44	25.54	25.48	25.38	25.19	25.32	25.35	24.98	25.09	24.83
		1	215	25.55	25.53	25.49	25.57	25.56	25.43	25.24	25.43	25.40	24.99	24.89	24.85
		108	54	25.45	25.55	25.51	25.58	25.59	25.45	25.34	25.43	25.41	25.01	24.98	24.89
		216	0	25.57	25.58	25.58	25.70	25.68	25.50	25.35	25.45	25.46	25.09	25.08	24.93
	QPSK	1	0	25.00	24.99	25.28	25.29	25.19	24.99	24.23	24.67	25.05	24.80	24.66	24.58
		1	1	25.30	25.53	25.59	25.64	25.52	25.66	25.09	25.34	25.37	25.20	25.06	24.91
		1	214	25.51	25.46	25.42	25.52	25.57	25.33	25.26	25.28	25.37	24.99	24.99	24.92
		1	215	25.22	24.99	25.03	25.12	25.28	25.21	24.82	24.71	25.02	24.57	24.43	24.53
		108	54	25.46	25.59	25.58	25.66	25.62	25.44	25.29	25.39	25.50	25.09	25.04	25.03
		216	0	25.09	25.17	25.17	25.30	25.32	25.10	24.69	25.02	24.94	24.73	24.70	24.57
	16QAM	1	0	24.12	23.98	24.26	24.12	24.26	24.29	23.70	23.85	23.89	23.77	23.68	23.70
		1	1	25.09	25.15	25.23	25.44	25.17	25.11	24.54	24.62	25.02	24.38	24.84	24.77
		1	214	25.29	25.27	24.72	25.26	25.28	24.99	24.90	24.47	25.08	24.31	24.88	24.43
		1	215	23.65	23.78	24.06	24.18	24.08	23.77	23.64	23.74	23.95	23.86	23.69	23.44
		108	54	25.04	25.22	25.15	25.29	25.22	25.15	24.95	25.01	24.91	24.68	24.67	24.64
		216	0	24.17	24.16	24.21	24.28	24.28	24.15	24.01	24.00	24.10	23.72	23.71	23.68
	64QAM	1	0	23.77	23.61	24.06	23.94	23.84	23.67	23.15	23.24	23.24	23.20	23.22	23.23
		1	1	23.44	23.57	23.92	23.77	23.93	23.74	23.08	23.30	23.52	23.37	23.45	23.08
		1	214	23.48	23.99	23.56	23.56	23.63	23.74	23.43	23.38	23.61	23.14	23.20	22.97
		1	215	23.53	23.68	23.61	23.72	23.80	23.62	23.22	23.13	23.58	23.12	23.19	23.07
		108	54	23.52	23.69	23.68	23.73	23.70	23.72	23.53	23.46	23.58	23.16	23.16	23.13
		216	0	23.67	23.73	23.66	23.78	23.77	23.70	23.59	23.47	23.60	23.28	23.20	23.20
	256QAM	1	0	21.37	21.92	22.09	21.62	21.91	21.86	21.59	21.51	21.45	21.67	21.22	21.38
		1	1	21.90	21.95	21.99	21.82	22.13	22.11	21.72	21.36	21.80	21.40	21.17	21.18
		1	214	21.84	21.96	21.67	21.75	21.84	21.73	21.28	21.61	21.55	21.38	21.29	21.12
		1	215	21.79	21.63	21.64	21.78	21.86	21.72	21.63	21.46	21.51	21.25	21.24	21.26
		108	54	21.46	21.70	21.53	21.72	21.63	21.64	21.53	21.39	21.47	21.25	21.09	21.12
		216	0	21.69	21.65	21.57	21.73	21.65	21.66	21.46	21.42	21.50	21.29	21.16	21.13

8.12. 5G NR n70

Test Engineer ID:	25780	Test Date:	2024-02-24
-------------------	-------	------------	------------

OUTPUT POWER FOR 5G NR n70 (5.0 MHz)

Bandwidth (MHz)	Modulation	RB Allocation	RB Offset	Conducted Average (dBm)											
				ANT 1			ANT 2			ANT 3			ANT 4		
				339500	340500	341500	339500	340500	341500	339500	340500	341500	339500	340500	341500
5.0	BPSK	1	0	25.50	25.37	25.44	25.46	25.29	25.29	25.17	25.15	25.31	24.77	24.68	24.72
		1	1	25.69	25.65	25.63	25.52	25.70	25.60	25.30	25.41	25.42	25.02	24.98	24.99
		1	23	25.70	25.56	25.56	25.49	25.51	25.59	25.37	25.50	25.35	24.96	24.94	24.80
		1	24	25.39	25.33	25.30	25.27	25.00	24.76	25.13	25.15	25.23	24.60	24.58	24.61
		12	6	25.58	25.54	25.57	25.54	25.18	25.32	25.33	25.32	25.40	24.89	24.95	24.91
		25	0	25.30	25.30	25.27	25.13	24.76	24.85	25.08	25.06	25.14	24.63	24.52	24.51
	QPSK	1	0	24.93	24.86	24.79	24.65	24.40	24.42	24.67	24.54	24.64	24.10	24.06	24.26
		1	1	25.61	25.61	25.45	25.53	25.48	25.43	25.49	25.29	25.35	24.97	24.93	25.20
		1	23	25.65	25.66	25.47	25.61	25.34	25.51	25.39	25.34	25.35	24.97	24.85	24.87
		1	24	24.81	24.79	24.73	24.61	24.37	24.41	24.53	24.64	24.60	24.04	23.96	24.20
		12	6	25.59	25.58	25.46	25.64	25.46	25.47	25.32	25.41	25.36	24.96	24.90	24.96
		25	0	24.83	24.85	24.83	24.57	24.29	24.55	24.63	24.68	24.51	24.05	24.08	24.09
	16QAM	1	0	24.11	24.04	23.73	23.35	23.50	23.42	23.68	23.71	23.69	23.32	23.21	23.35
		1	1	24.73	24.83	25.18	24.68	24.63	24.82	24.92	24.67	24.56	24.06	24.14	23.93
		1	23	24.69	24.77	25.04	24.79	24.83	24.67	24.72	24.86	24.67	23.63	24.48	24.34
		1	24	23.75	23.66	23.82	23.68	23.64	23.97	23.84	23.90	23.99	23.37	23.23	23.21
		12	6	24.80	24.85	24.68	24.76	24.56	24.73	24.58	24.66	24.57	24.17	24.24	24.17
		25	0	23.73	23.81	23.78	23.73	23.61	23.60	23.54	23.61	23.56	23.23	23.19	23.29
	64QAM	1	0	23.30	23.34	23.16	23.40	23.07	23.22	23.33	22.90	23.22	22.77	22.76	22.79
		1	1	23.19	23.24	23.08	23.35	23.32	23.54	22.96	22.94	22.95	22.86	22.79	22.79
		1	23	23.50	23.36	23.19	23.52	23.57	23.33	23.12	23.09	23.30	22.63	22.64	22.88
		1	24	23.46	23.59	23.35	23.26	23.36	23.40	23.15	23.05	23.13	22.83	22.81	22.88
		12	6	23.46	23.33	23.38	23.25	23.32	23.34	23.25	23.12	23.29	22.65	22.67	22.62
		25	0	23.46	23.39	23.30	23.32	23.25	23.27	23.12	23.18	23.22	22.73	22.68	22.67
	256QAM	1	0	21.39	21.44	21.44	21.40	21.43	21.37	21.36	21.48	21.40	20.60	20.52	20.55
		1	1	21.49	21.44	21.77	21.42	21.01	21.37	21.39	21.35	21.34	20.68	20.73	20.64
		1	23	21.22	21.55	21.43	21.40	21.53	21.43	21.06	21.46	21.35	20.87	20.68	20.43
		1	24	21.53	21.50	21.33	21.59	21.41	21.32	21.09	21.18	21.61	20.53	20.31	20.48
		12	6	21.29	21.25	21.26	21.31	21.35	21.22	21.15	21.02	21.09	20.78	20.69	20.73
		25	0	21.36	21.31	21.30	21.36	21.33	21.30	21.19	21.15	21.27	20.74	20.69	20.64

OUTPUT POWER FOR 5G NR n70 (10.0 MHz)

Bandwidth (MHz)	Modulation	RB Allocation	RB Offset	Conducted Average (dBm)											
				ANT 1			ANT 2			ANT 3			ANT 4		
				340000	340500	341000	340000	340500	341000	340000	340500	341000	340000	340500	341000
10.0	BPSK	1	0	25.47	25.35	25.40	24.90	25.33	25.29	25.20	25.24	25.19	24.68	24.64	24.62
		1	1	25.69	25.70	25.62	25.43	25.70	25.63	25.39	25.44	25.50	24.91	24.86	24.94
		1	50	25.51	25.58	25.64	25.43	25.41	25.13	25.39	25.47	25.44	24.88	24.91	24.80
		1	51	25.33	25.39	25.26	24.95	24.96	24.88	25.17	25.10	25.27	24.50	24.36	24.54
		25	12	25.58	25.58	25.51	25.47	25.55	25.34	25.31	25.35	25.37	24.90	24.78	24.86
		50	0	25.45	25.45	25.33	25.00	24.77	24.92	25.15	25.28	25.29	24.61	24.58	24.55
	QPSK	1	0	24.91	24.84	24.83	24.41	24.37	24.61	24.72	24.68	24.60	23.97	24.14	24.13
		1	1	25.58	25.55	25.57	25.30	25.41	25.45	25.48	25.34	25.35	25.20	24.92	25.00
		1	50	25.59	25.50	25.42	25.24	25.33	25.37	25.41	25.33	25.37	24.94	24.85	24.92
		1	51	24.82	24.80	24.75	24.31	24.39	24.40	24.62	24.64	24.62	23.82	23.87	24.00
		25	12	25.63	25.65	25.64	25.38	25.41	25.26	25.37	25.43	25.41	24.93	24.86	24.93
		50	0	24.90	24.90	24.89	24.51	24.48	24.41	24.65	24.74	24.72	24.04	24.04	24.11
	16QAM	1	0	23.89	23.79	23.90	23.72	23.95	23.85	23.67	23.66	23.78	22.93	22.73	22.66
		1	1	24.68	25.20	24.73	24.33	24.29	24.77	24.66	24.89	25.19	24.00	24.16	24.11
		1	50	25.12	24.95	24.68	24.65	24.86	24.41	24.88	24.46	24.67	24.34	24.12	23.94
		1	51	23.62	23.80	23.71	23.43	23.47	23.73	23.91	23.84	23.57	23.00	22.88	22.83
		25	12	24.86	24.87	24.81	24.67	24.73	24.70	24.72	24.65	24.63	24.14	24.27	24.11
		50	0	23.96	23.99	23.89	23.85	23.44	23.66	23.66	23.78	23.79	23.18	23.19	23.14
	64QAM	1	0	23.34	23.39	23.43	23.33	23.40	23.09	23.11	23.25	22.99	22.79	22.60	22.66
		1	1	23.35	23.23	23.13	23.65	23.13	23.45	23.27	23.25	23.32	22.63	22.71	22.77
		1	50	23.21	23.30	23.34	22.97	23.13	23.50	23.20	22.91	23.10	22.67	22.67	22.46
		1	51	23.32	23.32	23.21	23.14	23.39	23.31	22.95	23.13	23.35	22.80	22.56	22.47
		25	12	23.37	23.39	23.42	23.27	23.32	23.42	23.21	23.24	23.36	22.75	22.73	22.68
		50	0	23.37	23.44	23.35	23.42	23.44	23.40	23.16	23.20	23.31	22.76	22.72	22.69
	256QAM	1	0	21.46	21.39	21.51	21.57	21.28	21.40	21.42	21.50	21.31	20.73	20.84	20.48
		1	1	21.39	21.36	21.21	21.70	21.22	21.20	21.39	21.36	21.23	20.64	20.52	20.50
		1	50	21.50	21.60	21.62	21.44	21.37	21.39	21.21	21.35	21.20	20.37	20.52	20.24
		1	51	21.31	21.27	21.33	21.65	21.55	21.48	21.16	21.03	21.33	20.25	20.59	20.24
		25	12	21.40	21.35	21.28	21.21	21.39	21.38	21.18	21.15	21.27	20.65	20.65	20.64
		50	0	21.36	21.29	21.27	21.42	21.35	21.46	21.15	21.18	21.26	20.71	20.63	20.71

OUTPUT POWER FOR 5G NR n70 (15.0 MHz)

Bandwidth (MHz)	Modulation	RB Allocation	RB Offset	Conducted Average (dBm)											
				ANT 1			ANT 2			ANT 3			ANT 4		
				N/A	340500	N/A	N/A	340500	N/A	N/A	340500	N/A	N/A	340500	N/A
15.0	BPSK	1	0		25.41			25.51			25.22		25.07		
		1	1		25.67			25.41			25.50		25.15		
		1	77		25.67			25.52			25.41		25.12		
		1	78		25.52			25.02			25.16		24.65		
		36	18		25.53			25.47			25.27		24.99		
		75	0		25.38			25.07			25.10		24.74		
	QPSK	1	0		25.01			24.69			24.72		24.30		
		1	1		25.70			25.70			25.37		25.20		
		1	77		25.56			25.39			25.41		25.17		
		1	78		24.86			24.63			24.65		24.19		
		36	18		25.60			25.49			25.28		25.04		
		75	0		24.98			24.58			24.67		24.24		
	16QAM	1	0		24.30			23.58			23.98		23.33		
		1	1		25.13			24.50			24.50		24.41		
		1	77		24.95			24.49			24.81		24.52		
		1	78		24.04			23.28			23.93		23.00		
		36	18		24.96			24.63			24.64		24.32		
		75	0		23.86			23.64			23.67		23.41		
	64QAM	1	0		23.19			23.15			23.15		23.05		
		1	1		23.32			23.33			23.06		23.18		
		1	77		23.18			23.14			22.96		22.85		
		1	78		23.21			23.26			23.05		23.00		
		36	18		23.42			23.34			23.20		22.90		
		75	0		23.42			23.33			23.15		22.98		
	256QAM	1	0		21.48			21.63			21.37		20.86		
		1	1		21.45			21.75			21.41		20.98		
		1	77		21.16			21.56			21.15		20.79		
		1	78		21.29			21.47			21.26		20.79		
		36	18		21.32			21.58			21.20		20.89		
		75	0		21.31			21.56			21.20		20.87		

8.13. LTE BAND 71 AND 5G NR n71

LTE BAND 71

Test Engineer ID:	12482	Test Date:	2023-08-27
-------------------	-------	------------	------------

OUTPUT POWER FOR LTE BAND 71 (5.0 MHz)

Bandwidth (MHz)	Modulation	RB Allocation	RB Offset	Conducted Average (dBm)					
				ANT 1			ANT 2		
				133147	133297	133447	133147	133297	133447
5.0	QPSK	1	0	25.08	25.17	25.23	25.10	25.09	25.06
		1	12	25.14	25.07	25.22	25.16	25.11	25.17
		1	24	25.57	25.60	25.70	25.14	25.13	24.92
		12	0	25.62	25.61	25.55	25.04	24.98	24.84
		12	6	25.21	25.26	25.44	25.11	25.17	25.17
		12	11	25.24	25.32	25.44	25.00	25.13	25.07
		25	0	24.72	24.66	24.70	24.35	24.58	24.59
	16QAM	1	0	25.02	25.17	25.18	25.07	25.16	25.19
		1	12	25.54	25.65	25.70	25.19	25.06	24.88
		1	24	25.17	25.16	25.31	24.64	24.47	24.28
		12	0	25.20	25.35	25.46	25.12	25.15	25.20
		12	6	24.83	24.89	25.07	24.50	24.59	24.57
		12	11	23.46	23.77	23.60	23.64	23.33	23.49
		25	0	24.63	24.45	24.66	24.77	24.52	24.23
	64QAM	1	0	25.19	25.29	25.02	24.43	24.64	24.29
		1	12	24.30	24.06	24.09	23.60	23.45	23.34
		1	24	24.82	25.02	25.02	24.47	24.58	24.61
		12	0	23.84	23.91	24.00	23.48	23.54	23.55
		12	6	23.38	23.25	23.28	22.70	22.94	22.99
		12	11	23.23	23.26	23.16	22.88	23.04	22.85
		25	0	23.74	23.80	23.60	22.84	22.90	22.73
	256QAM	1	0	23.52	23.71	23.55	23.00	23.09	22.71
		1	12	23.37	23.41	23.50	22.96	23.04	23.04
		1	24	23.30	23.38	23.55	23.00	23.11	23.10
		12	0	21.23	21.37	21.18	20.85	20.70	20.75
12		6	21.30	21.29	21.12	20.92	20.87	20.82	
12		11	21.75	21.65	21.60	20.75	20.76	20.68	
25		0	21.52	21.72	21.86	20.85	20.90	20.85	

OUTPUT POWER FOR LTE BAND 71 (10.0 MHz)

Bandwidth (MHz)	Modulation	RB Allocation	RB Offset	Conducted Average (dBm)					
				ANT 1			ANT 2		
				133172	133322	133422	133172	133322	133422
10.0	QPSK	1	0	25.58	25.61	25.63	25.10	25.09	25.17
		1	24	25.52	25.56	25.70	25.10	25.08	25.20
		1	49	25.47	25.54	25.62	25.00	25.07	25.08
		25	0	25.12	25.14	25.28	24.15	24.16	24.26
		25	12	25.18	25.22	25.31	24.23	24.24	24.23
		25	24	25.14	25.17	25.35	24.15	24.19	24.27
		50	0	25.16	25.17	25.27	24.19	24.20	24.25
	16QAM	1	0	25.38	25.32	25.42	24.39	24.35	24.44
		1	24	25.30	25.29	25.49	24.36	24.31	24.45
		1	49	25.29	25.32	25.37	24.28	24.37	24.42
		25	0	24.12	24.14	24.30	23.13	23.18	23.26
		25	12	24.20	24.22	24.30	23.22	23.27	23.26
		25	24	24.14	24.21	24.35	23.17	23.21	23.28
		50	0	24.18	24.20	24.27	23.17	23.22	23.22
	64QAM	1	0	24.42	24.55	24.57	23.44	23.59	23.59
		1	24	24.47	24.48	24.60	23.48	23.51	23.56
		1	49	24.37	24.57	24.48	23.40	23.53	23.47
		25	0	23.12	23.16	23.29	22.15	22.19	22.26
		25	12	23.23	23.25	23.29	22.21	22.27	22.27
		25	24	23.15	23.18	23.33	22.17	22.23	22.27
		50	0	23.17	23.21	23.27	22.20	22.23	22.26
	256QAM	1	0	21.20	21.23	21.24	20.27	20.23	20.35
		1	24	21.29	21.32	21.38	20.38	20.33	20.45
		1	49	21.17	21.33	21.29	20.29	20.31	20.38
		25	0	21.11	21.12	21.28	20.14	20.16	20.24
		25	12	21.19	21.23	21.29	20.20	20.22	20.27
		25	24	21.14	21.16	21.34	20.16	20.21	20.29
		50	0	21.15	21.19	21.28	20.19	20.22	20.21

OUTPUT POWER FOR LTE BAND 71 (15.0 MHz)

Bandwidth (MHz)	Modulation	RB Allocation	RB Offset	Conducted Average (dBm)					
				ANT 1			ANT 2		
				133197 670.5	133297 680.5	133397 690.5	133197 670.5	133297 680.5	133397 690.5
15.0	QPSK	1	0	25.51	25.56	25.64	25.10	25.13	25.20
		1	37	25.57	25.56	25.70	25.12	25.18	25.19
		1	74	25.44	25.47	25.50	25.07	25.10	25.12
		36	0	25.16	25.20	25.26	24.24	24.28	24.33
		36	16	25.22	25.14	25.25	24.33	24.23	24.33
		36	35	25.15	25.17	25.28	24.25	24.27	24.36
		75	0	25.21	25.23	25.25	24.32	24.31	24.33
	16QAM	1	0	25.21	25.36	25.45	24.44	24.47	24.54
		1	37	25.22	25.42	25.48	24.52	24.46	24.59
		1	74	25.10	25.36	25.33	24.46	24.41	24.40
		36	0	24.20	24.21	24.27	23.25	23.27	23.35
		36	16	24.23	24.18	24.26	23.32	23.26	23.34
		36	35	24.18	24.19	24.27	23.27	23.29	23.37
		75	0	24.24	24.23	24.25	23.33	23.34	23.37
	64QAM	1	0	24.45	24.47	24.47	23.50	23.47	23.61
		1	37	24.45	24.41	24.53	23.50	23.53	23.62
		1	74	24.27	24.30	24.38	23.44	23.57	23.47
		36	0	23.17	23.20	23.25	22.25	22.26	22.35
		36	16	23.22	23.18	23.24	22.31	22.24	22.35
		36	35	23.14	23.20	23.26	22.24	22.29	22.35
		75	0	23.25	23.26	23.24	22.32	22.34	22.37
	256QAM	1	0	21.22	21.25	21.28	20.40	20.35	20.40
		1	37	21.24	21.26	21.35	20.41	20.46	20.49
		1	74	21.34	21.34	21.30	20.44	20.53	20.39
36		0	21.18	21.22	21.24	20.29	20.29	20.36	
36		16	21.23	21.15	21.21	20.32	20.25	20.32	
36		35	21.19	21.20	21.25	20.29	20.30	20.38	
75		0	21.25	21.24	21.22	20.33	20.32	20.34	

OUTPUT POWER FOR LTE BAND 71 (20.0 MHz)

Bandwidth (MHz)	Modulation	RB Allocation	RB Offset	Conducted Average (dBm)					
				ANT 1			ANT 2		
				133222 673.0	133322 683.0	133372 688.0	133222 673.0	133322 683.0	133372 688.0
20.0	QPSK	1	0	25.56	25.70	25.63	25.16	25.16	25.14
		1	49	25.61	25.61	25.66	25.13	25.13	25.20
		1	99	25.59	25.70	25.59	25.09	25.16	25.11
		50	0	25.29	25.33	25.27	24.29	24.31	24.29
		50	24	25.29	25.33	25.29	24.35	24.35	24.39
		50	49	25.28	25.31	25.28	24.27	24.33	24.34
		100	0	25.33	25.32	25.30	24.34	24.35	24.33
	16QAM	1	0	25.41	25.39	25.41	24.44	24.36	24.40
		1	49	25.66	25.56	25.70	24.56	24.70	24.69
		1	99	25.34	25.34	25.38	24.36	24.44	24.42
		50	0	24.29	24.30	24.27	23.29	23.28	23.29
		50	24	24.31	24.33	24.28	23.34	23.33	23.39
		50	49	24.28	24.31	24.30	23.26	23.32	23.34
		100	0	24.35	24.32	24.30	23.36	23.35	23.32
	64QAM	1	0	24.53	24.65	24.68	23.55	23.55	23.49
		1	49	24.67	24.74	24.78	23.60	23.55	23.66
		1	99	24.47	24.60	24.56	23.44	23.48	23.47
		50	0	23.33	23.31	23.29	22.29	22.31	22.31
		50	24	23.34	23.35	23.32	22.32	22.36	22.41
		50	49	23.30	23.30	23.33	22.27	22.34	22.35
		100	0	23.36	23.32	23.33	22.35	22.38	22.35
	256QAM	1	0	21.43	21.46	21.40	20.57	20.64	20.50
		1	49	21.41	21.42	21.49	20.53	20.50	20.49
		1	99	21.44	21.48	21.50	20.62	20.71	20.55
50		0	21.28	21.30	21.27	20.30	20.30	20.30	
50		24	21.33	21.33	21.28	20.32	20.34	20.39	
50		49	21.32	21.32	21.32	20.28	20.36	20.35	
100		0	21.34	21.32	21.31	20.33	20.37	20.34	

5G NR n71

Test Engineer ID:	25780	Test Date:	2024-02-23
-------------------	-------	------------	------------

OUTPUT POWER FOR 5G NR n71 (5.0 MHz)

Bandwidth (MHz)	Modulation	RB Allocation	RB Offset	Conducted Average (dBm)					
				ANT 1			ANT 2		
				133100	136100	139100	133100	136100	139100
5.0	BPSK	1	0	25.08	25.61	25.02	25.16	24.84	24.90
		1	1	25.17	25.65	25.00	25.20	24.73	24.86
		1	23	25.30	25.61	24.76	24.98	24.70	24.91
		1	24	25.31	25.64	24.78	25.03	24.81	24.91
		12	6	25.25	25.64	24.91	25.10	24.79	24.99
		25	0	25.13	25.57	24.88	24.94	24.73	24.76
	QPSK	1	0	24.69	25.26	24.63	24.79	24.37	24.47
		1	1	25.17	25.70	25.03	25.18	24.91	24.92
		1	23	25.28	25.41	24.82	25.03	24.74	24.82
		1	24	24.84	24.43	24.30	24.34	24.32	24.37
		12	6	25.25	25.65	24.84	25.08	24.85	24.82
		25	0	24.70	25.21	24.18	24.69	24.35	24.42
	16QAM	1	0	23.16	24.24	23.71	24.02	23.39	23.46
		1	1	24.74	25.36	24.81	25.12	24.17	24.56
		1	23	24.75	24.60	24.28	24.49	24.51	24.77
		1	24	24.21	23.55	23.13	23.40	23.54	23.38
		12	6	24.79	25.16	23.85	24.66	24.45	24.46
		25	0	23.70	24.25	23.10	23.60	23.28	23.45
	64QAM	1	0	23.10	23.82	22.95	22.89	22.81	22.76
		1	1	23.16	23.59	22.99	23.17	22.83	22.86
		1	23	23.29	23.23	22.92	22.82	22.92	22.59
		1	24	23.36	23.00	22.71	22.95	22.89	22.99
		12	6	23.26	23.65	22.21	23.22	22.88	23.06
		25	0	23.26	23.62	22.66	23.16	22.88	22.97
	256QAM	1	0	21.03	21.58	20.76	20.81	20.62	20.67
		1	1	20.77	21.73	21.04	20.89	20.91	20.92
		1	23	21.23	21.60	20.64	20.86	20.81	20.77
		1	24	20.92	21.42	20.62	20.92	20.63	20.83
		12	6	21.30	21.67	20.97	21.09	20.85	21.06
		25	0	21.29	21.80	20.98	21.20	20.97	21.01

OUTPUT POWER FOR 5G NR n71 (10.0 MHz)

Bandwidth (MHz)	Modulation	RB Allocation	RB Offset	Conducted Average (dBm)					
				ANT 1			ANT 2		
				133600	136600	138600	133600	136600	138600
10.0	BPSK	1	0	25.12	25.65	25.39	25.20	24.87	25.08
		1	1	25.13	25.70	25.41	25.19	24.92	24.98
		1	50	25.37	25.52	24.77	24.94	24.99	24.92
		1	51	25.39	25.54	24.77	24.89	24.93	24.94
		25	12	25.14	25.55	25.02	24.92	24.81	24.80
		50	0	25.17	25.55	25.07	24.96	24.83	24.85
	QPSK	1	0	24.64	25.15	24.99	24.76	24.53	24.62
		1	1	25.02	25.68	25.40	25.18	24.92	24.96
		1	50	25.40	25.51	24.80	24.88	24.99	24.95
		1	51	24.68	24.98	24.42	24.50	24.51	24.56
		25	12	25.16	25.13	25.06	24.98	24.82	24.89
		50	0	24.76	24.91	24.61	24.60	24.47	24.49
	16QAM	1	0	23.48	24.52	24.16	24.49	23.63	23.92
		1	1	24.51	25.52	25.00	24.92	24.65	24.55
		1	50	24.40	24.78	24.42	24.69	24.61	24.48
		1	51	23.83	24.10	23.18	23.76	23.57	23.49
		25	12	24.80	24.18	24.64	24.57	24.34	24.51
		50	0	23.82	23.87	23.62	23.60	23.45	23.51
	64QAM	1	0	22.91	23.55	23.34	23.09	23.05	23.00
		1	1	22.98	23.32	23.56	23.12	22.90	22.98
		1	50	23.08	23.48	22.93	22.88	22.85	23.21
		1	51	23.25	23.48	22.70	23.22	22.89	23.11
		25	12	23.21	22.65	23.07	23.14	22.82	23.02
		50	0	23.34	23.29	23.12	23.13	22.95	23.05
	256QAM	1	0	20.60	21.39	21.17	20.91	20.89	20.99
		1	1	20.75	21.57	21.16	20.96	20.83	20.96
		1	50	20.83	21.35	20.67	20.91	20.53	20.92
		1	51	21.03	21.22	20.51	21.02	20.75	20.85
		25	12	21.24	21.21	21.09	21.11	21.04	21.14
		50	0	21.33	21.59	21.12	21.14	20.99	21.08

OUTPUT POWER FOR 5G NR n71 (15.0 MHz)

Bandwidth (MHz)	Modulation	RB Allocation	RB Offset	Conducted Average (dBm)					
				ANT 1			ANT 2		
				134100	136100	138100	134100	136100	138100
15.0	BPSK	1	0	25.12	25.65	25.39	25.20	24.87	25.08
		1	1	25.13	25.70	25.41	25.19	24.92	24.98
		1	77	25.37	25.52	24.77	24.94	24.99	24.92
		1	78	25.39	25.54	24.77	24.89	24.93	24.94
		36	18	25.14	25.55	25.02	24.92	24.81	24.80
		75	0	25.17	25.55	25.07	24.96	24.83	24.85
	QPSK	1	0	24.64	25.15	24.99	24.76	24.53	24.62
		1	1	25.02	25.68	25.40	25.18	24.92	24.96
		1	77	25.40	25.51	24.80	24.88	24.99	24.95
		1	78	24.68	24.98	24.42	24.50	24.51	24.56
		36	18	25.16	25.13	25.06	24.98	24.82	24.89
		75	0	24.76	24.91	24.61	24.60	24.47	24.49
	16QAM	1	0	23.48	24.52	24.16	24.49	23.63	23.92
		1	1	24.51	25.52	25.00	24.92	24.65	24.55
		1	77	24.40	24.78	24.42	24.69	24.61	24.48
		1	78	23.83	24.10	23.18	23.76	23.57	23.49
		36	18	24.80	24.18	24.64	24.57	24.34	24.51
		75	0	23.82	23.87	23.62	23.60	23.45	23.51
	64QAM	1	0	22.91	23.55	23.34	23.09	23.05	23.00
		1	1	22.98	23.32	23.56	23.12	22.90	22.98
		1	77	23.08	23.48	22.93	22.88	22.85	23.21
		1	78	23.25	23.48	22.70	23.22	22.89	23.11
		36	18	23.21	22.65	23.07	23.14	22.82	23.02
		75	0	23.34	23.29	23.12	23.13	22.95	23.05
	256QAM	1	0	20.60	21.39	21.17	20.91	20.89	20.99
		1	1	20.75	21.57	21.16	20.96	20.83	20.96
		1	77	20.83	21.35	20.67	20.91	20.53	20.92
		1	78	21.03	21.22	20.51	21.02	20.75	20.85
		36	18	21.24	21.21	21.09	21.11	21.04	21.14
		75	0	21.33	21.59	21.12	21.14	20.99	21.08

OUTPUT POWER FOR 5G NR n71 (20.0 MHz)

Bandwidth (MHz)	Modulation	RB Allocation	RB Offset	Conducted Average (dBm)					
				ANT 1			ANT 2		
				134600	136600	137600	134600	136600	137600
20.0	BPSK	1	0	25.04	25.40	25.70	25.15	24.84	24.80
		1	1	25.04	25.33	25.59	25.20	24.77	24.77
		1	104	25.51	25.07	24.76	24.73	24.73	24.79
		1	105	25.60	25.00	24.72	24.70	24.71	24.86
		50	25	25.43	25.44	25.30	24.99	24.79	24.84
		100	0	25.44	25.41	25.22	24.93	24.73	24.77
	QPSK	1	0	24.71	24.99	25.22	24.79	24.46	24.37
		1	1	25.13	25.33	25.64	25.06	24.87	24.76
		1	104	25.31	24.95	24.72	24.73	24.70	24.74
		1	105	24.42	24.58	24.23	24.43	24.44	24.45
		50	25	25.43	25.49	25.29	24.85	24.86	24.89
		100	0	25.05	25.03	24.88	24.49	24.36	24.34
	16QAM	1	0	23.62	24.24	24.09	23.32	23.42	23.33
		1	1	24.65	24.62	25.32	25.09	24.42	24.30
		1	104	24.34	24.67	24.11	24.61	24.42	24.14
		1	105	23.22	23.51	23.25	23.31	23.39	23.64
		50	25	25.09	24.93	24.95	24.55	24.36	24.45
		100	0	24.01	24.01	23.83	23.54	23.38	23.35
	64QAM	1	0	23.23	23.37	23.56	23.23	23.05	22.84
		1	1	23.04	23.27	23.59	23.23	22.71	22.73
		1	104	23.02	22.77	22.86	22.99	22.82	22.65
		1	105	22.64	23.01	22.68	22.72	23.00	22.85
		50	25	23.51	23.49	23.34	22.97	22.93	22.98
		100	0	23.56	23.47	23.35	22.96	22.86	22.83
	256QAM	1	0	20.70	21.43	21.53	20.61	20.86	20.78
		1	1	20.89	21.54	21.74	20.67	20.98	20.95
		1	104	21.26	20.79	20.70	20.83	20.69	20.59
		1	105	20.97	21.19	20.59	20.72	21.02	20.80
		50	25	21.51	21.60	21.42	20.96	20.85	20.95
		100	0	21.49	21.45	21.33	20.96	20.85	20.95

8.14. 5G NR n77 (FCC Part 27 3450-3550MHz)

Test Engineer ID:	28774	Test Date:	2024-02-21
-------------------	-------	------------	------------

OUTPUT POWER FOR 5G NR n77 (10.0 MHz)

Bandwidth (MHz)	Modulation	RB Allocation	RB Offset	Conducted Average (dBm)											
				ANT 7			ANT 8			ANT 9			ANT 4		
				630333 3455.0	633332 3500.0	636333 3545.0	630333 3455.0	633332 3500.0	636333 3545.0	630333 3455.0	633332 3500.0	636333 3545.0	630333 3455.0	633332 3500.0	636333 3545.0
10.0	BPSK	1	0	25.27	25.40	25.36	22.37	22.37	22.26	25.35	25.36	25.58	21.19	21.30	21.33
		1	1	28.50	28.65	28.54	25.56	25.56	25.32	28.49	28.53	28.56	24.49	24.44	24.63
		1	22	28.59	28.55	28.64	25.62	25.51	25.32	28.58	28.64	28.67	24.59	24.54	24.58
		1	23	25.25	25.39	25.34	22.37	22.34	22.27	25.41	25.35	25.40	21.34	21.32	21.28
		12	6	28.60	28.56	28.61	25.58	25.70	25.42	28.49	28.58	28.55	24.57	24.55	24.53
		24	0	28.44	28.39	28.41	25.44	25.35	25.25	28.30	28.32	28.44	24.40	24.36	24.32
	QPSK	1	0	25.35	25.48	25.43	22.51	22.43	22.26	25.43	25.42	25.48	21.36	21.29	21.32
		1	1	28.64	28.64	28.57	25.67	25.56	25.40	28.57	28.65	28.57	24.49	24.48	24.56
		1	22	28.64	28.70	28.67	25.68	25.55	25.53	28.62	28.63	28.70	24.70	24.51	24.55
		1	23	25.42	25.30	25.41	22.37	22.30	22.22	25.30	25.33	25.38	21.42	21.24	21.26
		12	6	28.57	28.63	28.58	25.63	25.53	25.43	28.57	28.62	28.59	24.57	24.48	24.47
		24	0	27.93	27.94	27.90	24.89	24.86	24.85	27.89	27.93	27.90	23.73	23.82	23.78
	16QAM	1	0	25.52	25.65	25.26	22.42	22.22	22.24	25.71	25.51	25.41	21.40	21.40	21.25
		1	1	27.77	28.35	27.79	25.19	24.74	24.79	27.68	27.89	27.65	23.71	23.74	23.60
		1	22	27.98	27.90	27.77	24.72	24.62	25.07	27.84	27.96	28.07	23.96	23.69	23.85
		1	23	25.86	25.18	25.39	21.75	22.30	22.36	25.24	25.19	25.70	21.14	21.46	21.05
		12	6	27.80	27.80	27.94	24.90	24.84	24.76	27.84	27.85	27.82	23.89	23.88	23.79
		24	0	26.85	26.85	26.88	23.88	23.82	23.77	26.83	27.00	26.91	22.73	22.86	22.78
	64QAM	1	0	25.35	25.41	25.36	22.14	22.26	21.52	25.32	25.36	25.18	20.84	20.78	20.74
		1	1	26.10	26.29	26.43	22.75	22.85	22.65	26.24	26.44	26.33	21.87	22.13	21.84
		1	22	26.47	26.37	26.52	23.10	23.07	22.65	26.50	26.32	26.17	22.03	21.93	21.89
		1	23	25.15	24.92	25.27	21.85	22.08	21.81	25.54	25.16	25.52	21.10	21.15	20.97
		12	6	26.27	26.36	26.32	23.40	23.28	23.17	26.34	26.45	26.40	22.35	22.39	22.19
		24	0	26.35	26.39	26.35	23.28	23.37	23.26	26.30	26.39	26.41	22.28	22.38	22.30
	256QAM	1	0	24.02	23.95	23.97	21.16	21.00	21.29	24.09	24.11	24.16	20.17	20.42	20.14
		1	1	23.73	24.07	24.14	21.28	21.17	21.16	24.05	24.05	24.21	20.14	20.22	19.88
		1	22	24.26	24.25	24.15	21.69	21.09	21.27	24.07	24.12	23.98	20.10	20.13	20.38
		1	23	23.96	24.33	24.14	21.32	21.20	21.22	24.02	24.05	23.98	20.31	20.21	20.24
		12	6	24.30	24.39	24.28	21.48	21.39	21.39	24.33	24.33	24.29	20.28	20.31	20.33
		24	0	24.31	24.37	24.43	21.49	21.37	21.35	24.33	24.41	24.42	20.31	20.39	20.29

OUTPUT POWER FOR 5G NR n77 (15.0 MHz)

Bandwidth (MHz)	Modulation	RB Allocation	RB Offset	Conducted Average (dBm)											
				ANT 7			ANT 8			ANT 9			ANT 4		
				630500 3457.5	633332 3500.0	636166 3542.5	630500 3457.5	633332 3500.0	636166 3542.5	630500 3457.5	633332 3500.0	636166 3542.5	630500 3457.5	633332 3500.0	636166 3542.5
15.0	BPSK	1	0	25.16	25.34	25.40	22.48	22.41	22.18	25.34	25.39	25.63	21.30	21.43	21.40
		1	1	28.27	28.65	28.63	25.70	25.53	25.45	28.60	28.61	28.70	24.52	24.64	24.54
		1	36	28.34	28.61	28.59	25.60	25.57	25.38	28.49	28.63	28.58	24.63	24.64	24.65
		1	37	25.06	25.34	25.38	22.42	22.39	22.24	25.41	25.32	25.49	21.37	21.46	21.43
		18	9	28.30	28.59	28.58	25.60	25.61	25.33	28.41	28.53	28.63	24.49	24.64	24.61
		36	0	28.15	28.40	28.40	25.40	25.40	25.27	28.25	28.35	28.35	24.30	24.44	24.41
	QPSK	1	0	25.11	25.40	25.38	22.44	22.36	22.31	25.33	25.40	25.33	21.32	21.49	21.41
		1	1	28.35	28.59	28.70	25.62	25.57	25.52	28.50	28.53	28.50	24.66	24.70	24.68
		1	36	28.45	28.66	28.70	25.68	25.60	25.52	28.61	28.60	28.65	24.55	24.60	24.59
		1	37	25.15	25.52	25.43	22.45	22.48	22.32	25.44	25.49	25.40	21.43	21.44	21.41
		18	9	28.22	28.63	28.62	25.59	25.54	25.37	28.53	28.48	28.52	24.59	24.55	24.56
		36	0	27.55	27.94	27.96	24.88	24.82	24.62	27.87	27.81	27.88	23.82	23.83	23.89
	16QAM	1	0	24.94	25.59	25.60	22.27	22.30	22.25	25.18	25.43	25.34	21.38	21.54	21.33
		1	1	27.71	27.79	27.32	24.90	25.04	24.61	27.88	27.92	27.81	23.98	23.84	23.82
		1	36	28.09	28.07	27.89	24.75	24.87	24.46	27.95	28.02	28.15	24.14	23.97	24.00
		1	37	25.50	25.55	25.46	22.20	22.54	22.38	24.99	25.53	25.51	21.63	21.38	21.45
		18	9	27.79	27.91	27.91	24.80	24.85	24.71	27.92	27.76	27.75	23.90	23.90	23.85
		36	0	26.81	26.86	26.87	23.86	23.78	23.66	26.82	26.81	26.82	22.77	22.74	22.84
	64QAM	1	0	25.38	25.33	25.60	22.08	21.71	21.73	25.45	25.28	25.17	20.93	21.23	21.29
		1	1	26.13	26.40	26.35	23.13	22.75	23.08	26.50	26.58	26.42	22.29	21.97	21.92
		1	36	26.11	26.45	26.48	23.05	22.80	22.99	26.31	26.23	26.46	22.01	21.71	21.81
		1	37	25.23	25.26	25.14	22.04	22.07	21.96	25.47	25.45	25.43	21.20	20.96	21.04
		18	9	26.38	26.43	26.42	23.45	23.31	23.21	26.39	26.50	26.46	22.55	22.40	22.45
		36	0	26.26	26.37	26.36	23.37	23.20	23.22	26.39	26.49	26.43	22.34	22.36	22.37
	256QAM	1	0	24.08	24.06	24.23	21.27	21.36	20.89	24.06	24.35	23.98	20.04	20.21	20.38
		1	1	24.23	24.14	24.13	21.04	20.99	21.13	24.03	24.33	24.57	20.27	20.15	20.31
		1	36	24.05	24.16	24.24	21.12	20.82	21.04	24.38	24.52	24.31	20.41	20.50	20.11
		1	37	24.15	24.11	23.93	21.35	20.97	21.11	24.16	24.49	24.32	20.24	20.63	20.29
		18	9	24.40	24.39	24.22	21.23	21.06	21.00	24.33	24.54	24.56	20.32	20.27	20.25
		36	0	24.26	24.28	24.21	21.42	21.29	21.19	24.37	24.50	24.44	20.48	20.43	20.32

OUTPUT POWER FOR 5G NR n77 (20.0 MHz)

Bandwidth (MHz)	Modulation	RB Allocation	RB Offset	ANT 7			ANT 8			ANT 9			ANT 4		
				630666	633332	635998	630666	633332	635998	630666	633332	635998	630666	633332	635998
				3460.0	3500.0	3540.0	3460.0	3500.0	3540.0	3460.0	3500.0	3540.0	3460.0	3500.0	3540.0
20.0	BPSK	1	0	25.04	24.99	25.26	22.35	22.27	22.07	25.36	25.29	25.48	21.48	21.08	21.24
		1	1	28.26	28.39	28.59	25.63	25.45	25.34	28.59	28.47	28.67	24.70	24.48	24.41
		1	49	28.35	28.41	28.70	25.61	25.45	25.32	28.59	28.53	28.70	24.69	24.48	24.50
		1	50	25.06	25.10	25.47	22.40	22.17	22.13	25.43	25.28	25.52	21.34	21.24	21.35
		25	12	28.28	28.30	28.55	25.58	25.45	25.25	28.55	28.48	28.60	24.38	24.52	24.51
		50	0	28.02	28.12	28.40	25.39	25.11	25.14	28.37	28.27	28.40	23.99	24.33	24.26
	QPSK	1	0	25.02	25.09	25.34	22.37	22.26	22.11	25.41	25.34	25.49	20.95	21.37	21.21
		1	1	28.29	28.34	28.69	25.66	25.53	25.39	28.51	28.59	28.65	24.07	24.58	24.57
		1	49	28.29	28.37	28.63	25.70	25.32	25.30	28.70	28.56	28.70	24.25	24.48	24.58
		1	50	25.11	25.18	25.39	22.40	22.18	22.10	25.48	25.35	25.46	20.96	21.28	21.30
		25	12	28.24	28.32	28.61	25.51	25.43	25.30	28.62	28.53	28.58	24.16	24.58	24.48
		50	0	27.54	27.63	27.90	24.77	24.76	24.62	27.79	27.86	27.88	23.44	23.84	23.83
	16QAM	1	0	25.14	24.80	25.73	22.29	22.43	21.82	25.40	25.37	24.89	20.72	21.53	20.92
		1	1	27.59	27.59	28.06	24.61	24.89	24.53	27.91	28.01	28.02	23.24	23.33	23.63
		1	49	27.40	27.75	27.70	24.93	24.51	24.85	28.06	28.13	28.13	23.55	23.97	24.07
		1	50	24.93	25.23	25.61	22.14	22.15	22.29	25.41	25.38	25.56	20.78	21.32	21.26
		25	12	27.56	27.63	27.89	24.81	24.66	24.54	27.82	28.00	27.85	23.40	23.84	23.83
		50	0	26.55	26.63	26.96	23.78	23.64	23.55	26.82	26.84	26.88	22.39	22.80	22.82
	64QAM	1	0	25.09	25.16	25.49	22.07	21.81	21.44	25.10	25.38	24.85	20.78	20.89	21.03
		1	1	25.96	26.16	26.38	22.48	22.96	22.80	26.21	26.54	26.40	21.58	22.03	21.87
		1	49	26.03	26.05	26.45	23.10	22.85	22.77	26.11	26.71	26.52	21.67	21.96	22.11
		1	50	25.08	25.17	25.29	22.00	21.94	21.65	25.57	25.29	25.23	20.74	20.93	20.71
		25	12	26.04	26.20	26.25	23.31	23.17	23.05	26.27	26.44	26.45	21.96	22.28	22.25
		50	0	26.01	26.09	26.33	23.21	23.16	23.08	26.30	26.38	26.36	21.86	22.34	22.28
	256QAM	1	0	23.76	23.94	24.23	21.21	21.42	20.82	24.05	24.15	24.03	19.60	20.26	20.10
		1	1	23.69	23.89	24.25	21.16	21.29	20.81	24.14	24.52	24.08	19.46	20.33	20.36
		1	49	23.75	23.81	24.32	21.15	21.03	21.01	24.11	24.34	24.14	19.71	20.03	19.88
		1	50	23.75	23.92	23.99	21.32	20.95	20.91	24.18	24.39	24.14	19.78	20.50	20.32
		25	12	23.94	24.19	24.37	21.24	21.12	21.03	24.23	24.43	24.56	19.94	20.23	20.30
		50	0	24.03	24.22	24.43	21.25	21.17	21.03	24.25	24.49	24.37	19.93	20.27	20.32

OUTPUT POWER FOR 5G NR n77 (30.0 MHz)

Bandwidth (MHz)	Modulation	RB Allocation	RB Offset	Conducted Average (dBm)											
				ANT 7			ANT 8			ANT 9			ANT 4		
				631000	633332	635666	631000	633332	635666	631000	633332	635666	631000	633332	635666
30.0	BPSK	1	0	25.23	25.21	25.16	22.42	22.39	22.28	25.23	25.26	24.96	21.29	21.35	21.42
		1	1	28.42	28.59	28.40	25.59	25.54	25.42	28.45	28.51	28.24	24.58	24.63	24.49
		1	76	28.70	28.58	28.33	25.62	25.53	25.50	28.56	28.51	28.12	24.70	24.51	24.50
		1	77	25.28	25.36	25.21	22.43	22.40	22.27	25.44	25.28	25.12	21.33	21.31	21.34
		36	18	28.50	28.51	28.33	25.68	25.57	25.42	28.47	28.41	28.09	24.61	24.56	24.58
		75	0	28.30	28.30	28.13	25.36	25.33	25.21	28.23	28.29	27.88	24.41	24.32	24.36
	QPSK	1	0	25.29	25.34	25.09	22.33	22.50	22.28	25.33	25.24	24.92	21.43	21.35	21.34
		1	1	28.57	28.66	28.35	25.57	25.55	25.58	28.57	28.57	28.20	24.62	24.56	24.53
		1	76	28.70	28.42	28.47	25.68	25.67	25.43	28.70	28.44	28.19	24.68	24.55	24.64
		1	77	25.37	25.26	25.11	22.43	22.34	22.23	25.53	25.23	25.03	21.41	21.45	21.36
		36	18	28.56	28.51	28.27	25.57	25.55	25.40	28.53	28.49	28.09	24.56	24.51	24.50
		75	0	27.81	27.80	27.69	24.88	24.81	24.75	27.84	27.82	27.39	23.93	23.85	23.78
	16QAM	1	0	25.73	25.44	25.45	22.17	22.43	22.12	25.25	25.48	25.19	21.66	21.47	21.40
		1	1	28.06	28.29	28.01	24.92	24.65	24.82	27.62	27.70	27.42	24.02	24.27	23.92
		1	76	27.60	27.84	27.70	24.99	24.71	24.16	27.84	27.46	27.79	24.22	23.80	23.69
		1	77	25.29	25.22	25.43	22.14	22.16	22.49	25.36	25.02	24.84	21.92	21.35	21.29
		36	18	27.81	27.85	27.59	24.87	24.86	24.68	27.80	27.46	27.26	23.92	23.79	23.80
		75	0	26.83	26.89	26.64	23.90	23.87	23.70	26.88	26.42	26.35	22.82	22.86	22.86
	64QAM	1	0	24.92	25.27	24.99	21.94	22.05	21.72	25.60	24.78	24.98	20.83	21.16	21.16
		1	1	26.15	26.11	25.64	22.88	22.53	22.74	26.17	26.01	25.97	21.88	21.74	22.08
		1	76	25.93	25.79	25.62	23.05	23.02	22.81	26.51	25.77	25.86	22.05	21.69	21.99
		1	77	24.89	24.68	24.34	22.25	21.67	21.75	25.34	24.94	25.07	20.94	21.05	21.08
		36	18	26.30	26.24	26.01	23.35	23.30	23.06	26.36	25.93	25.99	22.27	22.30	22.37
		75	0	26.37	26.26	26.13	23.39	23.33	23.12	26.24	25.92	25.93	22.33	22.32	22.34
	256QAM	1	0	24.32	24.52	24.24	21.36	21.41	21.39	24.14	24.17	23.68	20.06	20.47	20.34
		1	1	24.57	24.11	23.99	21.11	21.24	21.10	24.18	23.87	23.61	19.96	20.22	20.51
		1	76	24.11	24.19	24.20	21.38	21.45	20.97	23.95	23.55	23.54	20.09	20.32	20.56
		1	77	24.28	24.28	24.09	21.20	21.51	21.09	24.07	23.74	23.66	20.24	20.12	20.39
		36	18	24.26	24.18	24.02	21.35	21.33	21.26	24.21	23.91	23.86	20.31	20.29	20.32
		75	0	24.29	24.20	24.09	21.42	21.32	21.15	24.22	24.00	23.87	20.26	20.32	20.37

OUTPUT POWER FOR 5G NR n77 (40.0 MHz)

Bandwidth (MHz)	Modulation	RB Allocation	RB Offset	Conducted Average (dBm)											
				ANT 7			ANT 8			ANT 9			ANT 4		
				631332 3470.0	633332 3500.0	635332 3530.0	631332 3470.0	633332 3500.0	635332 3530.0	631332 3470.0	633332 3500.0	635332 3530.0	631332 3470.0	633332 3500.0	635332 3530.0
40.0	BPSK	1	0	25.29	25.33	25.42	22.52	22.27	22.28	25.40	25.57	25.40	21.44	21.42	21.42
		1	1	28.52	28.60	28.48	25.67	25.52	25.43	28.60	28.53	28.57	24.58	24.70	24.57
		1	104	28.42	28.52	28.61	25.70	25.38	25.31	28.70	28.49	28.61	24.69	24.60	24.68
		1	105	25.24	25.35	25.40	22.48	22.09	22.15	25.50	25.42	25.49	21.46	21.28	21.35
		50	25	28.40	28.45	28.49	25.63	25.29	25.24	28.43	28.51	28.52	24.59	24.55	24.54
	100	0	28.22	28.39	28.33	25.35	25.13	25.02	28.30	28.39	28.39	24.44	24.47	24.38	
	1	0	25.19	25.50	25.41	22.38	22.14	22.14	25.44	25.49	25.47	21.43	21.42	21.38	
	1	1	28.49	28.70	28.68	25.56	25.54	25.42	28.58	28.69	28.63	24.60	24.67	24.68	
	1	104	28.63	28.68	28.59	25.64	25.26	25.37	28.68	28.49	28.59	24.66	24.54	24.59	
	1	105	25.28	25.27	25.38	22.34	22.13	22.16	25.48	25.41	25.53	21.58	21.40	21.36	
	50	25	28.38	28.52	28.47	25.53	25.33	25.29	28.48	28.52	28.55	24.60	24.59	24.58	
	100	0	27.76	27.87	27.82	24.93	24.64	24.66	27.87	27.86	27.88	23.95	23.87	23.92	
	1	0	25.56	25.62	25.09	22.64	22.26	22.00	25.35	25.71	25.61	21.62	21.38	21.29	
	1	1	27.88	28.04	27.56	24.95	25.03	24.84	28.00	27.73	27.58	23.90	24.13	23.97	
	1	104	28.12	27.44	28.33	25.20	24.57	24.73	28.05	27.88	27.66	24.07	23.97	24.08	
	1	105	25.01	25.47	24.96	22.69	22.08	22.65	25.26	25.65	25.56	21.45	21.33	21.28	
	50	25	27.67	27.86	27.91	24.74	24.67	24.62	27.82	27.68	27.77	23.93	23.82	23.84	
	100	0	26.73	26.87	26.85	23.89	23.65	23.59	26.88	26.86	26.88	23.03	22.94	22.90	
	1	0	25.30	25.43	25.42	21.87	22.08	21.85	25.67	25.51	25.52	21.11	20.89	21.05	
	1	1	26.09	26.56	26.29	22.78	22.79	22.66	26.41	26.31	26.48	22.05	21.99	21.93	
	1	104	26.32	26.23	26.39	22.72	22.85	22.72	26.51	26.22	26.63	21.92	21.94	22.13	
	1	105	25.33	25.40	25.30	21.82	21.72	21.59	25.38	25.39	25.23	21.08	21.08	21.44	
	50	25	26.35	26.43	26.39	23.24	23.16	23.10	26.36	26.38	26.32	22.46	22.38	22.36	
	100	0	26.30	26.35	26.44	23.30	23.22	23.20	26.38	26.38	26.36	22.41	22.36	22.38	
	1	0	24.23	23.97	24.32	21.10	21.30	20.80	24.03	24.28	24.33	20.61	20.40	20.27	
	1	1	24.21	23.95	23.85	21.06	21.01	21.18	24.51	24.26	24.57	20.16	20.40	20.44	
	1	104	24.18	23.96	23.84	21.17	21.07	20.95	23.99	24.08	24.06	20.22	20.30	20.37	
	1	105	24.04	24.23	23.96	21.07	20.87	20.99	24.17	24.12	24.28	20.38	20.32	20.24	
	50	25	24.28	24.31	24.08	21.22	21.16	21.00	24.37	24.35	24.32	20.35	20.36	20.33	
	100	0	24.37	24.24	24.16	21.29	21.17	21.02	24.45	24.39	24.47	20.39	20.36	20.42	

OUTPUT POWER FOR 5G NR n77 (50.0 MHz)

Bandwidth (MHz)	Modulation	RB Allocation	RB Offset	Conducted Average (dBm)											
				ANT 7			ANT 8			ANT 9			ANT 4		
				631666 3475.0	633332 3500.0	634998 3525.0	631666 3475.0	633332 3500.0	634998 3525.0	631666 3475.0	633332 3500.0	634998 3525.0	631666 3475.0	633332 3500.0	634998 3525.0
50.0	BPSK	1	0	25.16	25.35	25.34	22.30	22.42	22.34	25.37	25.46	25.42	21.29	21.47	21.34
		1	1	28.41	28.57	28.61	25.64	25.63	25.67	28.39	28.54	28.44	24.63	24.69	24.56
		1	131	28.41	28.70	28.62	25.70	25.58	25.53	28.47	28.45	28.70	24.67	24.66	24.65
		1	132	25.13	25.37	25.45	22.42	22.27	22.33	25.33	25.30	25.29	21.39	21.29	21.42
		64	32	28.26	28.49	28.48	25.54	25.60	25.51	28.34	28.42	28.33	24.54	24.47	24.49
	128	0	28.09	28.29	28.33	25.31	25.38	25.27	28.10	28.21	28.13	24.25	24.24	24.26	
	1	0	25.10	25.46	25.35	22.36	22.45	22.39	25.26	25.36	25.30	21.43	21.37	21.37	
	1	1	28.32	28.59	28.63	25.67	25.68	25.64	28.35	28.55	28.43	24.66	24.64	24.60	
	1	131	28.39	28.60	28.67	25.56	25.52	25.68	28.63	28.47	28.55	24.70	24.49	24.61	
	1	132	25.19	25.30	25.44	22.30	22.39	22.43	25.29	25.41	25.27	21.46	21.29	21.32	
	64	32	28.31	28.49	28.50	25.56	25.51	25.41	28.34	28.41	28.35	24.60	24.49	24.45	
	128	0	27.58	27.83	27.83	24.71	24.89	24.80	27.69	27.77	27.70	23.83	23.79	23.78	
	1	0	25.42	25.59	25.40	22.04	22.30	22.21	25.10	25.28	25.46	21.61	21.19	21.79	
	1	1	27.57	27.85	28.16	25.13	24.80	25.11	27.60	28.04	27.31	24.10	23.97	23.69	
	1	131	27.60	27.94	27.96	24.84	24.99	25.15	27.58	28.06	28.00	24.23	23.61	23.75	
	1	132	25.27	25.72	25.37	22.25	22.26	22.50	25.33	25.35	25.48	21.21	21.45	21.96	
	64	32	27.66	27.80	27.83	24.81	24.83	24.73	27.78	27.74	27.64	23.93	23.77	23.99	
	128	0	26.65	26.85	26.89	23.89	23.91	23.81	26.73	26.74	26.71	22.81	22.85	22.97	
	1	0	25.11	25.32	25.43	21.81	22.21	21.99	25.56	25.43	25.24	20.66	20.92	20.93	
	1	1	26.07	26.51	26.10	23.12	23.20	23.12	25.99	26.32	26.48	21.91	22.04	21.57	
	1	131	26.17	26.26	26.43	23.51	23.19	22.96	26.50	26.19	26.13	21.78	22.27	22.65	
	1	132	25.22	25.38	25.06	21.76	21.84	21.97	25.36	25.20	25.56	20.90	20.99	21.25	
	64	32	26.13	26.30	26.31	23.27	23.33	23.20	26.35	26.20	26.21	22.31	22.18	22.42	
	128	0	26.12	26.28	26.27	23.31	23.35	23.21	26.34	26.20	26.32	22.31	22.32	22.46	
	1	0	23.96	24.32	24.05	21.23	21.39	21.19	24.10	24.11	24.07	20.02	20.53	20.39	
	1	1	24.04	24.03	24.05	21.32	21.03	20.91	24.15	24.02	24.08	20.55	20.42	20.53	
	1	131	24.05	24.00	23.84	21.25	20.95	21.11	24.20	24.41	24.10	20.19	20.18	20.42	
	1	132	24.26	24.08	24.11	21.07	21.42	21.36	24.12	24.13	24.09	20.49	20.25	20.52	
	64	32	24.23	24.18	24.25	21.25	21.39	21.23	24.30	24.20	24.28	20.32	20.26	20.46	
	128	0	24.28	24.27	24.29	21.23	21.38	21.24	24.32	24.23	24.29	20.31	20.31	20.44	

OUTPUT POWER FOR 5G NR n77 (60.0 MHz)

Bandwidth (MHz)	Modulation	RB Allocation	RB Offset	Conducted Average (dBm)											
				ANT 7			ANT 8			ANT 9			ANT 4		
				632000	633332	634666	632000	633332	634666	632000	633332	634666	632000	633332	634666
60.0	BPSK	1	0	25.16	25.35	25.34	22.30	22.42	22.34	25.37	25.46	25.42	21.29	21.47	21.34
		1	1	28.41	28.57	28.61	25.64	25.63	25.67	28.39	28.54	28.44	24.63	24.69	24.56
		1	160	28.41	28.70	28.62	25.70	25.58	25.53	28.47	28.45	28.70	24.67	24.66	24.65
		1	161	25.13	25.37	25.45	22.42	22.27	22.33	25.33	25.30	25.29	21.39	21.29	21.42
		81	40	28.26	28.49	28.48	25.54	25.60	25.51	28.34	28.42	28.33	24.54	24.47	24.49
		162	0	28.09	28.29	28.33	25.31	25.38	25.27	28.10	28.21	28.13	24.25	24.24	24.26
	QPSK	1	0	25.10	25.46	25.35	22.36	22.45	22.39	25.26	25.36	25.30	21.43	21.37	21.37
		1	1	28.32	28.59	28.63	25.67	25.68	25.64	28.35	28.55	28.43	24.66	24.64	24.60
		1	160	28.39	28.60	28.67	25.56	25.52	25.68	28.63	28.47	28.55	24.70	24.49	24.61
		1	161	25.19	25.30	25.44	22.30	22.39	22.43	25.29	25.41	25.27	21.46	21.29	21.32
		81	40	28.31	28.49	28.50	25.56	25.51	25.41	28.34	28.41	28.35	24.60	24.49	24.45
		162	0	27.58	27.83	27.83	24.71	24.89	24.80	27.69	27.77	27.70	23.83	23.79	23.78
	16QAM	1	0	25.42	25.59	25.40	22.04	22.30	22.21	25.10	25.28	25.46	21.61	21.19	21.79
		1	1	27.57	27.85	28.16	25.13	24.80	25.11	27.60	28.04	27.31	24.10	23.97	23.69
		1	160	27.60	27.94	27.96	24.84	24.99	25.15	27.58	28.06	28.00	24.23	23.61	23.75
		1	161	25.27	25.72	25.37	22.25	22.26	22.50	25.33	25.35	25.48	21.21	21.45	21.96
		81	40	27.66	27.80	27.83	24.81	24.83	24.73	27.78	27.74	27.64	23.93	23.77	23.99
		162	0	26.65	26.85	26.89	23.89	23.91	23.81	26.73	26.74	26.71	22.81	22.85	22.97
	64QAM	1	0	25.11	25.32	25.43	21.81	22.21	21.99	25.56	25.43	25.24	20.66	20.92	20.93
		1	1	26.07	26.51	26.10	23.12	23.20	23.12	25.99	26.32	26.48	21.91	22.04	21.57
		1	160	26.17	26.26	26.43	23.51	23.19	22.96	26.50	26.19	26.13	21.78	22.27	22.65
		1	161	25.22	25.38	25.06	21.76	21.84	21.97	25.36	25.20	25.56	20.90	20.99	21.25
		81	40	26.13	26.30	26.31	23.27	23.33	23.20	26.35	26.20	26.21	22.31	22.18	22.42
		162	0	26.12	26.28	26.27	23.31	23.35	23.21	26.34	26.20	26.32	22.31	22.32	22.46
	256QAM	1	0	23.96	24.32	24.05	21.23	21.39	21.19	24.10	24.11	24.07	20.02	20.53	20.39
		1	1	24.04	24.03	24.05	21.32	21.03	20.91	24.15	24.02	24.08	20.55	20.42	20.53
		1	160	24.05	24.00	23.84	21.25	20.95	21.11	24.20	24.41	24.10	20.19	20.18	20.42
		1	161	24.26	24.08	24.11	21.07	21.42	21.36	24.12	24.13	24.09	20.49	20.25	20.52
		81	40	24.23	24.18	24.25	21.25	21.39	21.23	24.30	24.20	24.28	20.32	20.26	20.46
		162	0	24.28	24.27	24.29	21.23	21.38	21.24	24.32	24.23	24.29	20.31	20.31	20.44

OUTPUT POWER FOR 5G NR n77 (70.0 MHz)

Bandwidth (MHz)	Modulation	RB Allocation	RB Offset	Conducted Average (dBm)											
				ANT 7			ANT 8			ANT 9			ANT 4		
				632333	633332	634333	632333	633332	634333	632333	633332	634333	632333	633332	634333
70.0	BPSK	1	0	25.12	25.29	24.95	22.39	22.27	22.36	25.26	25.20	25.23	21.39	21.26	21.40
		1	1	28.56	28.39	28.25	25.70	25.53	25.68	28.53	28.61	28.63	24.63	24.49	24.58
		1	187	28.53	28.42	28.39	25.42	25.34	25.40	28.63	28.53	28.39	24.51	24.49	24.51
		1	188	25.35	25.19	25.22	22.35	22.01	22.10	25.16	25.24	25.16	21.31	21.28	21.24
		90	45	28.55	28.31	28.29	25.62	25.54	25.46	28.63	28.63	28.35	24.70	24.54	24.55
		180	0	28.31	28.23	28.02	25.44	25.35	25.27	28.30	28.40	28.13	24.44	24.35	24.34
	QPSK	1	0	25.46	25.22	25.09	22.33	22.30	22.28	25.36	25.41	25.32	21.38	21.45	21.36
		1	1	28.56	28.70	28.38	25.55	25.69	25.53	28.65	28.53	28.49	24.67	24.60	24.53
		1	187	28.50	28.38	28.19	25.50	25.39	25.49	28.44	28.70	28.49	24.64	24.67	24.52
		1	188	25.36	25.26	25.06	22.27	22.24	22.06	25.14	25.41	25.12	21.43	21.39	21.18
		90	45	28.57	28.42	28.27	25.64	25.60	25.47	28.57	28.56	28.32	24.66	24.57	24.49
		180	0	27.82	27.74	27.51	24.95	24.83	24.69	27.83	27.89	27.59	23.90	23.86	23.79
	16QAM	1	0	25.13	25.15	25.42	22.20	22.34	22.42	25.51	24.87	25.29	21.62	21.72	21.49
		1	1	27.67	27.38	27.55	24.64	24.92	25.06	27.83	27.91	27.55	24.36	23.90	24.08
		1	187	27.57	27.76	27.83	24.44	24.95	24.38	28.34	28.65	27.73	23.38	23.82	23.82
		1	188	25.16	25.41	25.09	22.37	22.55	22.34	25.60	25.24	25.35	21.03	21.52	21.03
		90	45	27.81	27.79	27.53	24.90	24.90	24.74	27.83	27.82	27.69	23.93	23.94	23.92
		180	0	26.62	26.74	26.44	23.85	23.88	23.76	26.90	26.87	26.67	22.91	22.93	22.88
	64QAM	1	0	24.83	25.58	24.84	22.21	22.16	21.53	24.85	24.73	24.73	20.58	21.03	21.36
		1	1	26.30	26.26	25.79	22.63	23.19	22.77	25.85	26.11	25.70	22.06	21.66	22.16
		1	187	26.30	26.43	26.42	22.85	22.65	22.61	25.61	25.99	25.75	21.70	22.18	21.73
		1	188	25.40	25.06	24.85	21.55	21.70	21.63	25.26	24.86	24.83	20.89	20.88	20.89
		90	45	26.18	26.25	26.21	23.42	23.34	23.27	26.43	26.44	26.21	22.44	22.39	22.43
		180	0	26.16	26.23	26.04	23.30	23.31	23.26	26.42	26.39	26.11	22.39	22.36	22.40
	256QAM	1	0	23.84	24.10	23.81	21.46	21.41	21.27	24.16	24.14	24.01	20.42	20.14	20.40
		1	1	24.38	24.39	23.93	21.26	21.25	21.28	24.07	23.84	23.96	20.19	20.23	20.50
		1	187	24.02	24.17	23.80	21.20	20.99	21.22	24.25	24.47	24.06	20.08	20.02	20.29
		1	188	23.86	23.84	23.75	21.18	21.02	21.05	24.35	24.69	23.95	20.28	19.99	20.35
		90	45	24.27	24.06	24.12	21.34	21.36	21.25	24.48	24.41	24.15	20.36	20.36	20.38
		180	0	24.26	24.04	24.17	21.33	21.34	21.24	24.29	24.39	24.20	20.34	20.37	20.39

OUTPUT POWER FOR 5G NR n77 (80.0 MHz)

Bandwidth (MHz)	Modulation	RB Allocation	RB Offset	Conducted Average (dBm)											
				ANT 7			ANT 8			ANT 9			ANT 4		
				632666	633332	633998	632666	633332	633998	632666	633332	633998	632666	633332	633998
80.0	BPSK	1	0	25.30	25.38	25.45	22.33	22.53	22.35	25.26	25.26	25.29	21.27	21.52	21.37
		1	1	28.60	28.66	28.60	25.62	25.68	25.66	28.46	28.50	28.44	24.59	24.69	24.65
		1	215	28.44	28.54	28.70	25.32	25.38	25.41	28.45	28.48	28.37	24.53	24.70	24.59
		1	216	25.29	25.49	25.35	22.15	22.08	22.11	25.31	25.16	25.11	21.30	21.27	21.34
		108	54	28.61	28.64	28.60	25.58	25.50	25.49	28.56	28.55	28.53	24.53	24.68	24.49
		216	0	28.36	28.45	28.41	25.32	25.35	25.32	28.36	28.25	28.36	24.35	24.49	24.30
	QPSK	1	0	25.38	25.55	25.39	22.31	22.42	22.44	25.44	25.52	25.16	21.36	21.42	21.34
		1	1	28.56	28.63	28.60	25.64	25.70	25.63	28.46	28.70	28.68	24.54	24.66	24.62
		1	215	28.65	28.59	28.45	25.38	25.49	25.38	28.61	28.44	28.49	24.57	24.64	24.42
		1	216	25.38	25.32	25.38	22.12	22.07	22.15	25.24	25.36	25.13	21.28	21.31	21.48
		108	54	28.62	28.65	28.57	25.52	25.52	25.48	28.55	28.48	28.51	24.54	24.66	24.48
		216	0	27.90	27.95	27.85	24.86	24.81	24.74	27.84	27.80	27.86	23.84	23.83	23.76
	16QAM	1	0	24.94	25.74	25.45	22.38	22.22	21.96	25.61	25.13	25.38	21.19	21.37	21.54
		1	1	27.90	28.02	27.97	25.24	24.81	25.15	28.05	28.01	27.67	23.98	23.89	23.89
		1	215	28.03	28.06	28.07	25.06	24.85	24.67	28.18	27.82	27.71	23.61	24.09	23.89
		1	216	25.32	25.83	25.62	22.10	22.06	22.08	25.41	25.40	25.14	21.11	21.46	21.43
		108	54	27.94	27.91	27.99	24.85	24.76	24.71	27.78	27.86	27.82	23.75	23.89	23.83
		216	0	26.88	26.95	26.96	23.89	23.75	23.73	26.79	26.73	26.84	22.79	22.77	22.90
	64QAM	1	0	25.13	25.37	25.32	21.69	21.79	21.60	24.82	24.75	24.65	21.16	21.09	21.14
		1	1	26.38	26.18	26.35	22.84	23.10	22.61	25.70	25.53	26.13	21.95	22.01	22.33
		1	215	26.33	26.54	26.38	22.92	22.64	23.08	25.89	25.58	25.77	21.55	22.05	22.09
		1	216	25.45	25.51	25.28	21.76	21.85	21.85	24.88	25.23	24.83	20.85	21.15	21.04
		108	54	26.44	26.51	26.47	23.41	23.30	23.18	26.28	26.42	26.28	22.42	22.43	22.38
		216	0	26.43	26.39	26.34	23.35	23.24	23.24	26.26	26.33	26.33	22.44	22.36	22.40
	256QAM	1	0	24.52	23.90	23.88	21.34	21.30	21.25	24.22	24.15	24.05	20.21	20.33	20.03
		1	1	24.57	24.38	24.21	21.56	21.16	21.45	24.59	24.22	24.19	20.32	20.25	20.41
		1	215	24.18	24.41	24.12	20.91	20.99	21.06	24.19	23.85	23.89	20.20	20.08	20.16
		1	216	24.08	24.23	24.33	21.17	20.94	20.91	24.08	24.20	24.10	20.23	20.12	20.35
		108	54	24.63	24.36	24.43	21.38	21.25	21.13	24.22	24.35	24.22	20.44	20.36	20.33
		216	0	24.62	24.33	24.49	21.34	21.24	21.20	24.26	24.39	24.19	20.42	20.34	20.40

OUTPUT POWER FOR 5G NR n77 (90.0 MHz)

Bandwidth (MHz)	Modulation	RB Allocation	RB Offset	Conducted Average (dBm)											
				ANT 7			ANT 8			ANT 9			ANT 4		
				633000	633332	633666	633000	633332	633666	633000	633332	633666	633000	633332	633666
90.0	BPSK	1	0	25.36	25.46	25.20	22.36	22.45	25.09	25.26	25.03	21.05	21.23	21.45	
		1	1	28.66	28.70	28.44	25.47	25.66	25.60	28.35	28.44	28.43	24.53	24.42	24.62
		1	243	28.57	28.61	28.58	25.46	25.42	25.51	28.55	28.45	28.62	24.54	24.38	24.63
		1	244	25.41	25.36	25.27	22.12	22.29	22.29	25.16	25.23	25.25	21.21	21.26	21.44
		120	60	28.54	28.55	28.52	25.54	25.62	25.60	28.48	28.44	28.54	24.52	24.54	24.55
		243	0	28.35	28.33	28.36	25.38	25.39	25.39	28.28	28.23	28.30	24.25	24.37	24.29
	QPSK	1	0	25.33	25.19	25.44	22.55	22.37	22.54	25.16	25.21	25.29	21.18	21.13	21.30
		1	1	28.59	28.45	28.54	25.56	25.41	25.70	28.30	28.66	28.47	24.66	24.53	24.70
		1	243	28.45	28.51	28.57	25.41	25.50	25.47	28.49	28.56	28.70	24.42	24.53	24.58
		1	244	25.40	25.41	25.32	22.17	22.14	22.24	25.20	25.33	25.16	21.37	21.27	21.15
		120	60	28.53	28.51	28.50	25.62	25.61	25.56	28.57	28.50	28.50	24.55	24.60	24.49
		243	0	27.77	27.80	27.87	24.84	24.88	24.77	27.83	27.84	27.89	23.72	23.85	23.83
	16QAM	1	0	24.64	25.15	25.67	22.40	22.58	22.41	25.37	25.16	25.21	21.15	20.65	21.51
		1	1	28.31	27.77	27.97	25.33	25.26	25.22	27.62	27.41	27.83	23.83	23.95	23.70
		1	243	28.01	28.40	27.67	24.44	24.67	24.71	28.02	27.56	27.66	23.56	23.85	23.83
		1	244	25.61	25.29	25.66	22.20	22.30	22.23	25.10	25.41	25.05	21.41	21.23	21.26
		120	60	27.77	27.77	27.86	24.90	24.80	24.96	27.79	27.80	27.82	23.71	23.83	23.56
		243	0	26.85	26.80	26.74	23.85	23.88	23.85	26.75	26.79	26.87	22.70	22.84	22.81
	64QAM	1	0	24.93	25.15	25.10	22.13	22.12	22.02	24.36	24.43	24.67	20.81	20.60	20.95
		1	1	26.12	26.06	26.11	22.91	22.68	23.10	26.02	26.31	25.61	21.78	21.61	22.00
		1	243	26.27	26.34	26.58	22.96	22.89	22.87	25.97	25.73	26.13	21.89	22.20	22.06
		1	244	25.42	25.37	25.09	21.87	21.43	21.50	25.03	25.06	24.69	20.74	21.19	20.69
		120	60	26.38	26.37	26.46	23.39	23.36	23.34	26.29	26.28	26.36	22.24	22.39	22.32
		243	0	26.33	26.33	26.29	23.43	23.40	23.35	26.24	26.28	26.37	22.20	22.45	22.45
	256QAM	1	0	24.02	23.75	24.14	21.12	21.33	21.32	24.13	24.51	24.02	20.00	20.29	20.59
		1	1	24.08	24.02	24.03	21.24	21.06	21.51	24.29	23.93	24.18	19.81	20.04	20.33
		1	243	24.11	24.07	24.18	21.35	21.55	20.96	23.82	24.21	23.99	20.10	20.21	20.20
		1	244	24.13	24.38	24.12	20.84	21.37	20.92	24.12	24.31	24.34	19.78	20.29	19.72
		120	60	24.39	24.38	24.34	21.36	21.34	21.29	24.28	24.36	24.25	20.27	20.28	20.24
		243	0	24.37	24.23	24.36	21.37	21.38	21.32	24.27	24.32	24.32	20.19	20.38	20.34

OUTPUT POWER FOR 5G NR n77 (100.0 MHz)

Bandwidth (MHz)	Modulation	RB Allocation	RB Offset	Conducted Average (dBm)											
				ANT 7			ANT 8			ANT 9			ANT 4		
				N/A	633332	N/A	N/A	633332	N/A	N/A	633332	N/A	N/A	633332	N/A
100.0	BPSK	1	0		25.28			22.12			25.08			21.48	
		1	1		28.51			25.58			28.45			24.42	
		1	271		28.70			25.48			28.50			24.70	
		1	272		25.19			22.27			25.34			21.45	
		135	67		28.59			25.58			28.48			24.69	
		270	0		28.23			25.36			28.22			24.35	
	QPSK	1	0		25.29			22.49			25.37			21.32	
		1	1		28.42			25.70			28.38			24.48	
		1	271		28.54			25.49			28.70			24.68	
		1	272		25.19			22.31			25.18			21.34	
		135	67		28.50			25.54			28.40			24.64	
		270	0		27.81			24.82			27.68			23.83	
	16QAM	1	0		25.62			22.36			25.07			21.71	
		1	1		27.92			24.39			27.66			24.13	
		1	271		27.90			24.61			27.87			23.84	
		1	272		25.56			22.40			25.36			21.10	
		135	67		27.97			24.92			27.72			23.94	
		270	0		26.87			23.90			26.73			22.95	
	64QAM	1	0		24.99			22.26			24.53			21.14	
		1	1		26.84			22.58			25.97			22.15	
		1	271		26.40			22.84			25.76			22.25	
		1	272		25.31			21.85			25.11			21.15	
		135	67		26.49			23.38			26.27			22.53	
		270	0		26.43			23.37			26.33			22.47	
	256QAM	1	0		24.56			21.16			23.97			20.52	
		1	1		24.17			21.33			24.15			20.20	
		1	271		24.36			20.90			24.68			20.41	
		1	272		24.20			21.03			23.92			19.97	
		135	67		24.51			21.28			24.32			20.52	
		270	0		24.40			21.28			24.34			20.48	

8.15. 5G NR n77 (FCC Part 27 3700-3980MHz)

Test Engineer ID:	25780	Test Date:	2024-02-19
-------------------	-------	------------	------------

OUTPUT POWER FOR 5G NR n77 (10.0 MHz)

Bandwidth (MHz)	Modulation	RB Allocation	RB Offset	Conducted Average (dBm)											
				ANT 7			ANT 8			ANT 9			ANT 4		
				647000 3705.0	656000 3840.0	665000 3975.0	647000 3705.0	656000 3840.0	665000 3975.0	647000 3705.0	656000 3840.0	665000 3975.0	647000 3705.0	656000 3840.0	665000 3975.0
10.0	BPSK	1	0	24.98	25.19	25.36	22.18	21.96	22.90	25.15	25.20	24.97	21.40	20.74	20.87
		1	1	28.42	28.44	28.70	24.48	24.27	25.21	28.36	28.47	28.18	24.57	23.91	24.00
		1	22	28.47	28.49	28.67	24.75	24.12	25.70	28.56	28.69	28.65	24.58	23.87	24.17
		1	23	25.14	25.33	25.38	22.52	21.86	23.49	25.30	25.54	25.42	21.49	20.61	20.83
		12	6	28.44	28.49	28.60	24.67	24.21	25.37	28.22	28.55	28.43	24.70	23.91	24.10
	QPSK	24	0	28.21	28.32	28.45	24.59	24.19	24.10	27.96	28.39	28.20	24.17	23.68	23.93
		1	0	25.05	25.19	25.37	22.32	22.08	21.47	25.14	25.22	24.87	21.10	20.77	20.93
		1	1	28.25	28.52	28.59	24.58	24.18	24.68	28.29	28.31	28.12	24.41	23.94	24.05
		1	22	28.46	28.41	28.69	24.74	24.01	24.57	27.59	28.65	28.70	24.45	23.78	24.30
		1	23	25.18	25.27	25.40	22.59	21.74	22.32	25.33	25.49	25.44	21.25	20.57	20.92
	16QAM	12	6	28.29	28.40	28.67	24.65	24.16	24.00	27.35	28.53	28.40	24.45	23.90	24.02
		24	0	27.22	27.29	27.88	24.67	24.14	24.03	26.35	27.86	27.73	23.65	23.23	23.43
		1	0	25.46	25.15	25.55	22.52	22.26	21.67	25.14	25.07	25.03	21.50	20.85	20.20
		1	1	27.58	27.75	28.06	24.26	24.21	24.06	27.06	27.51	27.41	23.99	23.18	23.85
		1	22	27.89	27.42	27.86	24.66	24.25	24.41	26.75	27.79	28.08	23.53	23.26	23.53
	64QAM	1	23	25.24	24.90	25.44	22.43	22.27	22.36	25.04	25.83	25.86	21.21	20.59	20.96
		12	6	27.37	27.40	27.93	24.66	24.17	23.95	26.45	27.86	27.79	23.68	23.22	23.42
		24	0	26.15	26.29	26.87	23.96	23.56	23.33	25.41	26.90	26.78	22.65	22.30	22.38
		1	0	25.27	24.92	25.28	22.58	22.20	21.89	25.14	25.18	25.29	20.99	20.40	20.58
		1	1	26.24	25.87	26.41	23.53	23.29	22.50	26.08	26.02	25.89	21.72	21.43	21.16
	256QAM	1	22	26.28	26.03	26.04	23.49	23.12	23.53	25.16	26.44	26.67	21.99	21.43	21.96
		1	23	25.19	25.00	25.45	22.72	21.99	22.44	25.41	25.39	25.27	20.86	20.06	20.44
		12	6	25.91	25.99	26.37	23.43	22.81	22.79	24.83	26.30	26.10	22.22	21.72	21.88
		24	0	25.94	25.85	26.28	23.46	22.85	22.86	24.92	26.30	26.18	22.21	21.72	21.86
		1	0	23.89	24.00	24.28	21.29	21.09	20.47	24.01	24.01	23.84	20.03	19.49	19.86

OUTPUT POWER FOR 5G NR n77 (15.0 MHz)

Bandwidth (MHz)	Modulation	RB Allocation	RB Offset	Conducted Average (dBm)											
				ANT 7			ANT 8			ANT 9			ANT 4		
				647166 3707.5	656000 3840.0	664833 3972.5	647166 3707.5	656000 3840.0	664833 3972.5	647166 3707.5	656000 3840.0	664833 3972.5	647166 3707.5	656000 3840.0	664833 3972.5
15.0	BPSK	1	0	25.39	25.31	25.49	22.29	23.14	21.71	24.97	25.02	24.28	21.41	21.19	20.91
		1	1	28.65	28.49	28.70	24.42	25.22	23.96	28.39	28.30	27.65	24.70	24.44	24.26
		1	36	28.52	28.53	28.60	24.89	25.48	25.05	28.43	28.59	28.35	24.62	24.23	24.38
		1	37	25.24	25.29	25.42	22.61	23.31	22.94	25.43	25.45	25.14	21.44	21.03	21.09
		18	9	28.56	28.49	28.63	24.60	25.25	24.29	27.84	28.45	27.90	24.62	24.36	24.23
	QPSK	36	0	28.37	28.30	28.48	24.61	25.29	24.37	27.39	28.26	27.69	24.44	24.18	24.05
		1	0	25.39	25.26	25.38	22.28	23.03	21.78	25.14	25.00	24.46	21.52	21.17	21.07
		1	1	28.50	28.30	28.65	24.44	25.37	23.96	28.16	27.76	27.64	24.63	24.41	24.28
		1	36	28.36	28.26	28.56	24.81	25.54	25.12	27.39	28.70	28.32	24.64	24.31	24.26
		1	37	25.35	25.20	25.45	22.62	23.30	22.97	25.30	25.46	25.05	21.43	21.17	21.04
	16QAM	18	9	27.97	27.96	28.60	24.57	25.22	24.27	26.86	28.46	27.89	24.59	24.33	24.26
		36	0	27.09	27.10	27.92	24.63	25.29	24.36	25.90	27.75	27.12	23.89	23.64	23.55
		1	0	25.37	25.28	25.30	21.94	22.85	21.78	25.16	24.82	24.52	21.13	20.99	21.14
		1	1	27.43	27.74	28.01	24.84	24.99	23.59	27.12	26.90	27.01	23.85	23.92	23.59
		1	36	27.57	27.52	27.74	24.77	25.70	25.27	26.43	28.07	27.48	24.10	23.42	23.71
	64QAM	1	37	25.20	25.13	25.64	22.64	23.38	23.12	25.34	25.39	25.08	21.41	20.96	20.86
		18	9	27.08	26.95	27.84	24.63	25.34	24.34	25.85	27.71	27.16	23.79	23.60	23.55
		36	0	26.11	26.17	26.85	23.86	24.43	23.69	24.97	26.74	26.13	22.81	22.52	22.48
		1	0	25.37	25.33	25.62	22.37	23.41	22.06	24.89	24.99	24.55	21.04	20.83	20.48
		1	1	26.30	25.93	26.28	23.46	24.07	23.08	25.77	25.52	25.16	22.08	22.00	21.63
	256QAM	1	36	26.18	25.71	26.14	24.15	24.59	24.06	24.91	26.43	26.06	22.05	21.58	21.78
		1	37	25.04	25.09	25.48	22.70	23.58	23.25	25.23	25.34	25.22	21.04	20.57	20.36
		18	9	25.55	25.57	26.36	23.33	23.86	23.07	24.47	26.21	25.60	22.42	22.11	21.87
		36	0	25.58	25.67	26.42	23.40	23.92	23.12	24.46	26.22	25.62	22.45	22.07	21.95
		1	0	24.28	23.74	24.22	21.31	22.22	20.55	24.03	23.81	23.52	20.47	20.03	19.91

OUTPUT POWER FOR 5G NR n77 (20.0 MHz)

Bandwidth (MHz)	Modulation	RB Allocation	RB Offset	Conducted Average (dBm)											
				ANT 7			ANT 8			ANT 9			ANT 4		
				647333	656000	664666	647333	656000	664666	647333	656000	664666	647333	656000	664666
20.0	BPSK	1	0	25.40	25.22	25.44	22.19	22.95	21.67	25.10	24.98	24.16	21.40	21.15	21.09
		1	1	28.51	28.52	28.65	24.53	25.17	23.93	28.34	28.22	27.36	24.70	24.40	24.30
		1	49	28.24	28.49	28.70	24.98	24.64	24.50	28.58	28.70	28.11	24.66	24.22	24.32
		1	50	25.22	25.21	25.37	23.07	22.48	22.16	25.49	25.40	24.90	21.38	20.95	21.04
		25	12	28.45	28.47	28.66	25.67	24.96	23.91	27.78	28.46	27.62	24.53	24.39	24.30
		50	0	28.21	28.29	28.45	25.60	24.94	23.99	27.57	28.32	27.47	24.38	24.16	23.97
	QPSK	1	0	25.29	25.26	25.57	23.31	22.88	21.65	25.13	24.86	24.03	21.32	21.05	20.94
		1	1	28.14	28.17	28.57	25.54	24.99	23.80	28.07	27.54	27.41	24.59	24.42	24.26
		1	49	28.22	28.10	28.41	25.39	24.72	24.46	27.59	28.64	28.13	24.56	24.17	24.17
		1	50	25.07	25.26	25.34	23.23	22.46	22.29	25.44	25.48	24.92	21.34	20.89	21.06
		25	12	28.00	27.98	28.66	25.70	24.97	23.87	26.81	28.49	27.64	24.51	24.34	24.21
		50	0	27.04	27.16	27.90	25.59	24.95	24.03	25.93	27.72	26.99	23.82	23.56	23.48
	16QAM	1	0	25.41	25.26	25.47	23.62	23.05	21.54	25.07	25.15	23.84	21.16	21.05	21.10
		1	1	27.28	27.05	27.40	25.66	25.27	24.04	27.26	26.48	26.83	23.88	23.56	23.32
		1	49	26.99	27.42	27.25	25.41	25.05	24.58	26.74	27.91	27.62	24.07	23.22	23.74
		1	50	25.36	25.04	25.55	23.41	22.26	22.09	25.23	25.43	24.86	21.28	20.90	20.99
		25	12	27.03	27.07	27.70	25.67	24.95	23.87	25.78	27.66	26.89	23.79	23.59	23.42
		50	0	26.04	26.03	26.88	24.95	24.25	23.27	25.01	26.79	26.03	22.75	22.58	22.44
	64QAM	1	0	25.16	25.06	25.38	23.73	23.21	22.03	25.17	25.27	24.11	20.86	20.84	20.56
		1	1	25.87	25.75	26.14	24.09	24.04	22.77	25.87	25.07	25.06	21.98	21.21	21.50
		1	49	25.74	25.71	25.82	24.57	23.63	23.49	25.04	26.35	25.95	21.97	21.30	21.86
		1	50	25.21	25.11	25.40	23.62	22.76	22.29	25.21	25.57	24.83	20.82	20.16	21.12
		25	12	25.58	25.66	26.39	24.44	23.68	22.70	24.39	26.33	25.45	22.27	22.05	22.38
		50	0	25.55	25.55	26.36	24.31	23.74	22.63	24.51	26.26	25.41	22.27	22.00	22.42
	256QAM	1	0	23.61	24.02	24.11	22.14	21.81	20.54	24.25	23.35	23.17	20.34	19.83	20.21
		1	1	24.02	24.02	24.13	22.28	21.90	20.41	24.20	23.64	23.06	20.10	19.67	20.51
		1	49	23.69	24.03	24.35	22.53	21.32	21.44	23.89	24.59	24.00	20.25	19.80	20.42
		1	50	24.25	23.96	24.06	22.28	20.99	21.32	24.07	24.48	23.81	20.11	19.92	20.37
		25	12	24.18	24.24	24.39	22.42	21.74	20.60	22.83	24.28	23.36	20.42	20.07	20.26
		50	0	24.27	24.22	24.34	22.34	21.72	20.75	23.01	24.21	23.41	20.52	20.02	20.32

OUTPUT POWER FOR 5G NR n77 (30.0 MHz)

Bandwidth (MHz)	Modulation	RB Allocation	RB Offset	Conducted Average (dBm)											
				ANT 7			ANT 8			ANT 9			ANT 4		
				647666	656000	664333	647666	656000	664333	647666	656000	664333	647666	656000	664333
30.0	BPSK	1	0	24.66	24.47	23.95	22.81	22.88	21.45	24.52	24.31	23.00	21.36	21.15	20.72
		1	1	28.01	27.83	27.14	25.54	25.36	23.98	27.80	27.41	26.31	24.70	24.42	24.07
		1	76	28.27	28.68	27.86	25.26	24.87	24.55	28.69	28.05	26.94	24.57	24.04	24.16
		1	77	25.02	25.33	24.64	22.68	22.25	22.11	25.43	24.71	23.53	21.34	20.78	20.95
		36	18	27.94	27.76	27.25	25.70	25.16	23.81	27.93	27.60	26.21	24.59	24.24	23.95
		75	0	27.78	27.88	27.00	25.58	25.15	23.92	28.01	27.44	26.14	24.34	24.07	23.76
	QPSK	1	0	24.60	24.54	23.87	22.86	22.85	21.60	24.54	24.21	23.15	21.41	21.12	20.63
		1	1	27.99	27.50	26.30	25.41	25.33	23.98	27.64	27.50	26.24	24.58	24.46	23.86
		1	76	27.78	28.70	27.84	25.34	24.91	24.62	28.70	28.08	26.91	24.54	24.15	24.13
		1	77	25.09	25.18	24.63	22.77	22.34	22.05	25.48	24.69	23.66	21.41	20.81	20.82
		36	18	27.93	26.65	27.17	25.67	25.14	23.83	26.97	27.58	26.17	24.65	24.24	23.85
		75	0	27.23	26.19	26.46	25.57	25.09	23.94	26.44	26.94	25.60	23.96	23.42	23.18
	16QAM	1	0	24.81	24.40	24.12	22.84	22.54	21.34	24.51	24.07	23.42	21.28	20.96	20.49
		1	1	27.42	26.40	25.68	25.00	25.30	23.78	26.79	26.80	25.50	24.00	23.55	22.93
		1	76	26.82	27.71	27.05	25.33	24.52	24.74	27.93	27.45	25.72	24.24	23.36	23.38
		1	77	24.93	25.38	24.71	23.01	22.23	21.65	25.30	24.62	23.47	21.32	20.69	21.19
		36	18	27.16	25.75	26.58	25.64	24.66	23.83	25.94	26.87	25.23	24.00	23.51	23.31
		75	0	26.21	25.10	25.50	24.59	24.00	22.89	25.37	25.93	24.34	22.93	22.50	22.31
	64QAM	1	0	24.70	24.42	23.71	22.57	23.00	21.19	23.90	23.94	22.67	21.07	20.72	20.35
		1	1	25.46	25.04	24.05	23.84	23.65	22.17	25.34	24.93	23.83	21.95	21.55	21.13
		1	76	25.43	25.99	25.58	23.57	23.20	23.15	26.33	25.78	24.30	22.02	21.23	21.65
		1	77	24.88	25.12	24.48	22.63	22.26	22.01	24.99	24.88	23.40	20.84	20.57	20.67
		36	18	25.66	24.33	24.88	24.15	23.17	22.25	24.54	25.37	23.72	22.21	22.02	21.78
		75	0	25.68	24.69	25.05	24.07	23.53	22.39	24.85	25.38	23.91	22.25	21.99	21.81
	256QAM	1	0	23.91	23.72	22.66	22.17	22.15	20.54	23.65	23.33	22.33	20.06	20.33	19.70
		1	1	23.98	23.75	22.46	22.24	22.08	20.67	23.79	23.79	22.04	20.11	20.01	19.66
		1	76	24.46	24.53	23.77	22.07	21.53	21.40	24.54	23.98	22.70	20.25	19.63	19.83
		1	77	24.16	24.41	23.68	21.68	21.63	21.41	24.47	24.27	22.64	20.06	19.80	19.91
		36	18	23.63	22.81	22.93	22.21	21.57	20.47	23.11	23.31	21.73	20.24	20.02	19.76
		75	0	23.68	23.14	22.98	22.05	21.52	20.54	23.42	23.39	21.79	20.12	20.01	19.81

OUTPUT POWER FOR 5G NR n77 (40.0 MHz)

Bandwidth (MHz)	Modulation	RB Allocation	RB Offset	Conducted Average (dBm)											
				ANT 7			ANT 8			ANT 9			ANT 4		
				648000	656000	664000	648000	656000	664000	648000	656000	664000	648000	656000	664000
40.0	BPSK	1	0	24.73	25.03	25.29	23.20	22.93	21.92	24.82	24.74	23.73	21.32	21.39	20.79
		1	1	28.05	28.23	28.67	25.41	25.16	24.21	28.00	27.93	26.98	24.40	24.57	24.08
		1	104	28.00	28.70	28.59	25.28	24.71	24.16	28.70	28.62	27.54	24.67	24.37	24.21
		1	105	24.85	25.41	25.11	22.93	22.52	22.01	25.48	25.33	24.09	21.47	21.05	20.93
		50	25	27.98	28.42	28.47	25.68	25.03	23.62	27.48	28.32	26.87	24.54	24.61	24.02
	QPSK	100	0	27.72	28.25	28.30	25.55	24.99	23.80	27.40	28.12	26.75	24.34	24.34	23.90
		1	0	24.81	24.97	25.43	23.24	22.97	22.00	24.90	24.82	23.61	21.34	21.59	20.94
		1	1	27.72	28.02	28.42	25.43	25.34	24.15	27.82	27.20	26.87	24.48	24.70	24.05
		1	104	27.82	28.35	28.34	25.30	24.75	24.07	28.70	28.48	27.50	24.58	24.33	24.19
		1	105	24.77	25.25	25.17	22.94	22.38	21.89	25.60	25.34	24.18	21.35	20.86	21.06
	16QAM	50	25	27.43	27.91	28.47	25.70	24.95	23.61	26.63	28.34	26.81	24.49	24.52	24.12
		100	0	26.47	27.06	27.68	25.62	25.03	23.75	26.02	27.54	26.28	23.67	23.84	23.45
		1	0	24.61	25.23	25.65	23.25	23.01	21.76	24.71	24.74	23.59	21.46	21.38	21.15
		1	1	26.48	27.60	27.40	25.69	25.07	24.54	26.67	25.80	25.84	23.65	23.84	23.76
		1	104	27.19	27.17	27.03	25.63	24.82	23.90	27.68	27.87	26.53	24.06	23.75	23.45
	64QAM	1	105	24.66	25.55	25.15	23.43	22.85	21.92	25.58	25.56	24.38	21.45	20.95	21.30
		50	25	26.35	26.92	27.57	25.62	25.01	23.57	25.40	27.16	26.15	23.70	23.80	23.33
		100	0	25.54	26.08	26.65	24.79	24.30	23.09	24.98	26.57	25.20	22.81	22.82	22.54
		1	0	24.45	24.63	25.51	23.25	22.86	22.05	24.84	24.43	23.97	20.78	21.03	20.40
		1	1	25.12	25.49	26.10	24.42	24.06	22.70	25.46	24.80	24.68	22.43	22.26	21.42
	256QAM	1	104	25.50	26.14	25.83	24.29	23.71	23.17	26.34	26.24	25.03	21.72	21.52	21.57
		1	105	24.64	25.32	25.12	23.15	22.48	22.48	25.44	25.17	24.02	20.78	20.69	20.87
		50	25	24.95	25.47	26.06	24.25	23.75	22.39	24.04	26.04	24.53	22.22	22.29	21.97
		100	0	25.10	25.67	26.18	24.29	23.77	22.53	24.46	26.14	24.68	22.24	22.27	22.00
		1	0	23.77	23.77	24.12	22.04	22.05	20.67	24.09	23.32	22.58	20.22	20.22	19.49

OUTPUT POWER FOR 5G NR n77 (50.0 MHz)

Bandwidth (MHz)	Modulation	RB Allocation	RB Offset	Conducted Average (dBm)											
				ANT 7			ANT 8			ANT 9			ANT 4		
				648333	656000	663666	648333	656000	663666	648333	656000	663666	648333	656000	663666
50.0	BPSK	1	0	24.92	24.94	25.40	23.08	22.99	22.34	25.36	25.07	24.24	21.22	21.51	20.50
		1	1	28.13	28.22	28.70	25.34	25.07	24.45	28.57	28.19	27.62	24.64	24.70	23.68
		1	131	28.03	28.48	28.33	24.39	24.65	23.93	28.52	28.70	27.80	24.65	24.01	23.88
		1	132	24.69	25.23	25.11	22.27	22.40	21.71	25.45	25.37	24.45	21.33	20.72	20.71
		64	32	27.91	28.41	28.48	25.22	24.86	23.46	28.00	28.37	27.07	24.43	24.20	23.60
	QPSK	128	0	27.69	28.17	28.20	25.16	24.79	23.67	28.14	28.26	26.94	24.25	24.02	23.48
		1	0	24.89	24.91	25.40	23.09	22.95	22.34	25.18	24.91	24.31	21.45	21.41	20.38
		1	1	27.88	27.74	28.41	25.40	25.11	24.39	27.95	27.16	26.82	24.57	24.58	23.67
		1	131	27.99	28.02	28.01	24.55	24.53	24.01	28.63	28.61	27.82	24.62	24.06	24.07
		1	132	24.86	25.43	25.28	22.24	22.41	21.56	25.23	25.54	24.47	21.27	20.70	20.75
	16QAM	64	32	27.56	27.90	28.39	25.30	24.73	23.53	27.22	28.46	26.98	24.36	24.20	23.70
		128	0	26.70	26.89	27.63	25.15	24.85	23.69	26.85	27.77	26.42	23.71	23.51	23.09
		1	0	24.54	25.22	25.39	23.12	22.93	22.66	25.20	24.98	24.45	21.22	21.40	20.34
		1	1	26.73	26.71	27.08	25.70	24.75	24.43	26.98	26.14	25.97	23.94	24.19	23.36
		1	131	27.10	27.30	27.79	23.90	24.55	24.26	27.99	28.10	27.11	23.06	23.08	23.28
	64QAM	1	132	24.82	25.61	25.25	22.38	22.29	21.74	25.32	25.66	24.31	21.46	20.80	20.64
		64	32	26.55	26.88	27.51	25.20	24.77	23.56	26.11	27.58	26.46	23.60	23.44	23.00
		128	0	25.68	25.99	26.64	24.44	24.12	23.02	25.82	26.67	25.61	22.67	22.49	22.07
		1	0	24.91	25.18	25.00	23.48	23.00	22.29	25.23	24.90	24.17	20.89	20.98	20.19
		1	1	25.39	25.27	26.02	24.40	24.19	23.45	25.43	25.11	24.71	22.00	21.72	21.53
	256QAM	1	131	25.18	25.52	25.74	23.11	23.83	23.13	26.23	26.02	25.83	21.98	21.28	21.35
		1	132	24.80	25.22	24.75	22.62	22.68	22.48	25.23	25.37	24.49	20.80	20.54	20.47
		64	32	25.05	25.45	26.17	23.93	23.52	22.33	24.73	26.04	24.98	22.13	21.98	21.48
		128	0	25.19	25.48	26.21	23.89	23.59	22.55	25.31	26.19	25.17	22.18	22.00	21.60
		1	0	23.88	23.60	24.07	22.09	21.65	21.31	24.23	23.53	22.97	19.91	19.99	19.43

OUTPUT POWER FOR 5G NR n77 (60.0 MHz)

Bandwidth (MHz)	Modulation	RB Allocation	RB Offset	Conducted Average (dBm)											
				ANT 7			ANT 8			ANT 9			ANT 4		
				648666	656000	663333	648666	656000	663333	648666	656000	663333	648666	656000	663333
60.0	BPSK	1	0	24.91	24.94	25.41	23.02	22.39	21.79	24.95	24.99	24.27	21.31	21.19	20.63
		1	1	28.12	28.19	28.69	25.15	24.64	23.99	27.93	28.28	27.48	24.59	24.70	23.94
		1	160	28.32	28.70	28.55	23.88	24.39	23.83	27.69	28.48	27.73	24.55	23.97	24.03
		1	161	25.06	25.53	25.24	21.64	22.13	21.54	24.43	25.42	24.56	21.34	20.79	20.76
		81	40	28.13	28.48	28.58	24.98	24.64	23.57	28.70	28.57	27.07	24.63	24.29	23.82
		162	0	27.92	28.23	28.36	24.90	24.62	23.63	28.29	28.32	27.00	24.40	24.05	23.68
	QPSK	1	0	24.93	24.90	25.40	23.00	22.41	21.68	24.91	25.07	24.34	21.41	21.25	20.68
		1	1	27.99	27.79	28.58	25.15	24.67	24.13	28.05	27.77	27.22	24.58	24.54	23.90
		1	160	28.54	28.48	28.55	23.88	24.31	23.77	27.70	28.54	27.74	24.45	24.01	24.09
		1	161	25.14	25.39	25.34	21.66	22.23	21.78	24.47	25.32	24.47	21.38	20.85	20.84
		81	40	27.84	28.12	28.60	24.99	24.63	23.59	27.98	28.57	27.12	24.65	24.31	23.96
		162	0	27.05	27.33	27.85	24.90	24.58	23.67	27.60	27.84	26.53	23.90	23.52	23.20
	16QAM	1	0	24.63	25.05	25.29	22.84	22.38	21.73	25.38	25.01	24.35	21.19	20.96	20.48
		1	1	27.11	27.12	27.89	25.70	24.23	23.70	26.86	26.52	26.63	23.87	23.74	23.74
		1	160	27.82	27.19	27.44	24.23	24.08	24.30	26.25	27.89	26.63	23.41	23.01	23.34
		1	161	24.96	25.52	25.32	22.16	22.12	21.64	24.48	25.53	24.43	20.94	20.95	20.88
		81	40	26.76	27.03	27.68	25.07	24.66	23.66	27.13	27.82	26.34	23.80	23.60	23.18
		162	0	26.04	26.26	26.77	24.22	23.92	22.97	26.60	26.82	25.50	22.82	22.55	22.29
	64QAM	1	0	24.92	24.74	25.37	23.21	22.36	21.81	24.73	24.62	24.33	20.95	20.40	20.18
		1	1	25.60	25.35	26.26	23.79	23.65	23.06	25.96	25.42	24.98	21.73	22.12	21.36
		1	160	26.15	26.14	25.98	23.52	23.40	22.68	25.59	25.91	25.43	21.80	21.42	21.62
		1	161	24.74	25.78	25.24	21.88	22.46	22.13	24.47	25.39	24.40	20.86	20.22	20.28
		81	40	25.43	25.77	26.33	23.85	23.52	22.43	25.85	26.33	24.84	22.31	21.99	21.73
		162	0	25.52	25.75	26.31	23.70	23.37	22.47	25.91	26.32	24.97	22.34	21.99	21.73
	256QAM	1	0	23.47	23.37	24.21	22.20	21.15	20.60	24.18	24.01	23.76	20.31	20.37	19.51
		1	1	23.55	23.69	24.11	21.71	21.44	20.87	24.05	24.03	22.81	20.16	20.17	19.61
		1	160	23.65	24.43	24.34	20.85	21.34	20.60	23.45	24.29	23.43	20.04	19.83	19.60
		1	161	23.83	24.52	23.95	20.37	20.74	20.56	23.09	24.53	23.48	20.55	19.60	19.63
		81	40	23.86	24.18	24.31	21.73	21.46	20.43	24.42	24.29	22.85	20.26	20.05	19.71
		162	0	23.84	24.10	24.23	21.68	21.37	20.43	24.25	24.25	22.99	20.34	19.93	19.69

OUTPUT POWER FOR 5G NR n77 (70.0 MHz)

Bandwidth (MHz)	Modulation	RB Allocation	RB Offset	Conducted Average (dBm)											
				ANT 7			ANT 8			ANT 9			ANT 4		
				649000	656000	663000	649000	656000	663000	649000	656000	663000	649000	656000	663000
70.0	BPSK	1	0	24.74	24.84	25.38	23.27	22.90	21.70	24.88	24.92	24.17	21.56	21.43	20.65
		1	1	28.20	28.10	28.70	25.58	24.89	23.89	28.40	28.10	27.42	24.51	24.55	23.75
		1	187	28.59	28.50	28.65	24.47	24.93	23.90	27.13	28.23	27.42	24.67	23.81	23.70
		1	188	25.19	25.16	25.12	22.33	22.84	21.87	24.07	24.91	24.37	21.41	20.52	20.65
		90	45	28.25	28.47	28.69	25.37	25.26	24.00	28.52	28.68	27.23	24.68	24.27	23.76
		180	0	28.08	28.26	28.52	25.32	25.22	24.02	27.95	28.34	27.11	24.50	24.04	23.59
	QPSK	1	0	24.80	24.76	25.60	23.46	22.79	21.86	24.87	24.88	24.16	21.49	21.40	20.67
		1	1	28.17	27.90	28.46	25.70	25.04	23.98	28.08	28.00	27.53	24.62	24.64	23.71
		1	187	28.27	28.57	28.50	24.39	24.99	23.97	27.25	28.32	27.48	24.64	23.80	23.89
		1	188	25.18	25.38	25.32	22.19	22.76	21.66	23.86	24.94	24.39	21.37	20.87	20.70
		90	45	28.01	28.01	28.55	25.38	25.28	24.08	28.52	28.70	27.18	24.70	24.30	23.81
		180	0	27.41	27.68	27.99	25.28	25.22	24.05	27.55	27.79	26.63	23.98	23.59	23.07
	16QAM	1	0	24.99	24.84	25.37	23.31	23.05	21.58	25.15	24.84	23.79	21.43	21.51	20.24
		1	1	27.23	27.09	27.43	25.60	24.77	23.70	26.95	27.28	27.07	24.04	24.16	22.77
		1	187	27.63	27.30	27.57	24.48	24.99	23.80	26.14	27.54	26.98	23.66	23.22	22.97
		1	188	25.02	25.68	25.60	22.43	22.62	21.80	24.11	24.72	24.24	21.28	21.12	20.25
		90	45	27.00	27.15	27.64	25.34	25.27	24.08	27.85	27.98	26.44	23.98	23.70	23.02
		180	0	26.29	26.46	26.97	24.57	24.54	23.34	26.56	26.73	25.52	22.95	22.71	22.04
	64QAM	1	0	24.23	24.51	25.38	23.74	23.31	21.71	25.26	24.94	24.76	20.93	21.13	20.14
		1	1	25.63	25.37	25.97	24.59	24.41	22.90	26.23	26.10	25.60	21.88	21.48	20.62
		1	187	26.18	25.84	26.23	23.77	23.65	23.39	25.23	25.95	25.31	21.80	21.29	21.61
		1	188	24.84	25.00	25.43	22.45	23.12	21.71	24.23	25.02	24.58	20.77	20.50	20.27
		90	45	25.52	25.70	26.26	24.13	24.01	22.85	26.27	26.28	24.98	22.44	22.22	21.53
		180	0	25.83	25.97	26.45	24.07	23.93	22.77	26.01	26.23	25.08	22.39	22.21	21.54
	256QAM	1	0	24.12	23.99	24.21	22.49	22.03	20.43	24.14	23.75	23.03	20.33	20.75	19.59
		1	1	23.73	23.42	24.53	22.17	21.89	20.64	24.07	24.03	23.05	20.25	20.29	19.56
		1	187	24.29	23.92	24.08	21.41	21.54	21.01	22.95	23.39	23.27	20.32	19.67	19.47
		1	188	24.07	24.34	24.24	21.19	21.66	20.79	23.08	23.93	23.11	20.13	19.69	19.37
		90	45	23.90	24.21	24.37	22.07	22.06	20.82	24.31	24.34	22.92	20.46	20.14	19.51
		180	0	24.05	24.21	24.42	22.07	21.98	20.80	24.02	24.24	23.05	20.39	20.17	19.52

OUTPUT POWER FOR 5G NR n77 (80.0 MHz)

Bandwidth (MHz)	Modulation	RB Allocation	RB Offset	Conducted Average (dBm)											
				ANT 7			ANT 8			ANT 9			ANT 4		
				649333	656000	662666	649333	656000	662666	649333	656000	662666	649333	656000	662666
80.0	BPSK	1	0	24.82	24.81	25.39	23.21	22.34	21.19	25.07	25.03	24.05	21.16	21.19	20.34
		1	1	28.24	28.00	28.66	25.70	24.72	23.57	28.24	28.28	27.38	24.21	24.34	23.74
		1	215	28.25	28.68	28.57	24.53	24.83	24.05	27.23	28.08	27.46	24.49	23.59	23.76
		1	216	25.25	25.44	25.21	22.31	22.62	21.61	24.03	24.88	23.99	21.14	20.39	20.38
		108	54	28.23	28.32	28.70	25.06	25.16	24.06	28.41	28.66	26.99	24.52	24.24	23.59
		216	0	28.02	28.10	28.51	25.12	25.03	23.80	27.96	28.34	26.86	24.19	24.03	23.44
	QPSK	1	0	24.78	24.42	25.38	23.13	22.43	21.30	25.02	24.90	23.73	21.25	21.36	20.57
		1	1	28.13	27.85	28.49	25.64	24.77	23.64	28.33	28.29	27.19	24.43	24.70	23.75
		1	215	28.40	28.46	28.45	24.14	24.96	23.94	27.19	27.98	27.46	24.49	23.67	23.79
		1	216	25.20	25.33	25.27	22.20	22.77	21.66	24.00	24.71	24.28	21.16	20.24	20.50
		108	54	28.00	28.08	28.35	25.17	25.23	23.99	28.39	28.70	27.10	24.53	24.26	23.61
		216	0	27.49	27.55	27.92	25.11	24.99	23.79	27.43	27.78	26.41	23.68	23.57	22.92
	16QAM	1	0	24.77	24.94	24.99	23.36	22.64	21.69	25.25	25.24	24.16	20.97	21.28	20.56
		1	1	27.20	26.32	27.39	25.18	24.96	23.32	27.39	27.28	26.48	23.71	23.91	23.01
		1	215	28.20	27.71	27.87	24.46	24.91	23.77	26.09	26.47	26.58	23.98	23.09	22.92
		1	216	25.27	25.66	25.05	21.98	22.81	21.99	23.80	25.03	24.23	21.18	21.01	20.47
		108	54	27.12	27.10	27.59	25.12	25.13	24.01	27.69	27.88	26.36	23.84	23.66	22.82
		216	0	26.34	26.40	26.86	24.41	24.38	23.14	26.52	26.78	25.42	22.71	22.59	21.90
	64QAM	1	0	24.66	24.48	25.45	23.60	22.78	21.90	25.21	25.29	24.47	20.97	20.66	19.48
		1	1	26.07	25.05	25.89	24.79	23.54	22.66	26.35	26.32	25.03	21.71	22.28	21.32
		1	215	25.85	26.04	26.01	23.85	23.95	22.80	24.93	25.80	25.35	21.16	20.86	21.02
		1	216	25.09	25.13	25.46	22.39	23.04	22.44	24.07	25.00	24.59	20.97	20.01	19.97
		108	54	25.57	25.64	26.13	23.80	23.97	22.80	26.13	26.36	24.77	22.29	22.10	21.38
		216	0	25.86	25.85	26.40	23.89	23.83	22.61	25.99	26.24	24.86	22.31	22.18	21.35
	256QAM	1	0	23.81	23.21	24.15	22.73	21.29	20.89	24.02	23.70	22.97	20.19	20.57	18.87
		1	1	23.64	23.32	24.64	22.25	21.59	20.40	23.76	24.00	23.02	20.18	19.69	19.29
		1	215	23.84	24.30	24.26	21.13	21.71	20.45	22.99	23.67	23.07	20.21	19.41	19.38
		1	216	23.96	24.21	24.26	21.18	21.51	20.45	22.74	23.69	22.95	20.55	19.20	19.29
		108	54	23.91	24.17	24.39	21.96	22.01	20.84	24.13	24.27	22.78	20.24	20.10	19.29
		216	0	23.93	24.14	24.33	21.94	21.94	20.64	23.91	24.23	22.77	20.24	20.09	19.32

OUTPUT POWER FOR 5G NR n77 (90.0 MHz)

Bandwidth (MHz)	Modulation	RB Allocation	RB Offset	Conducted Average (dBm)											
				ANT 7			ANT 8			ANT 9			ANT 4		
				649666	656000	662333	649666	656000	662333	649666	656000	662333	649666	656000	662333
90.0	BPSK	1	0	24.68	24.43	25.33	22.88	22.46	21.48	25.01	25.06	24.38	21.12	21.38	20.30
		1	1	27.83	27.85	28.63	25.66	25.13	23.95	28.49	28.38	27.65	24.51	24.54	23.73
		1	243	28.27	28.37	28.41	24.46	25.19	24.21	27.76	27.90	27.52	24.59	23.62	23.78
		1	244	24.97	25.35	25.09	22.00	22.51	21.75	24.66	24.74	24.38	21.35	20.60	20.42
		120	60	28.18	28.30	28.70	25.00	25.44	24.41	28.26	28.70	27.26	24.70	24.33	23.63
		243	0	27.97	27.99	28.46	25.15	25.32	24.07	28.02	28.21	27.11	24.35	24.05	23.48
	QPSK	1	0	24.72	24.51	25.45	23.09	22.40	21.51	25.13	25.00	24.44	21.27	21.40	20.47
		1	1	27.94	27.83	28.33	25.70	24.93	23.98	28.35	28.31	27.58	24.41	24.56	23.82
		1	243	28.39	28.38	28.32	24.43	25.08	24.18	27.91	27.16	27.81	24.55	23.74	23.86
		1	244	25.15	25.35	25.15	21.92	22.62	21.69	24.57	24.59	24.45	21.32	20.62	20.56
		120	60	27.96	27.91	28.29	24.99	25.35	24.40	28.26	28.68	27.25	24.66	24.25	23.64
		243	0	27.50	27.53	27.89	25.12	25.34	24.04	27.47	27.73	26.56	23.80	23.46	23.00
	16QAM	1	0	25.15	24.70	25.09	23.37	22.19	21.35	25.70	25.38	24.50	21.24	21.31	20.25
		1	1	27.08	26.76	27.03	25.41	24.84	24.09	27.50	27.69	27.18	23.54	23.94	23.18
		1	243	27.82	27.69	27.17	24.31	25.26	24.25	27.02	26.44	26.96	24.04	23.30	22.99
		1	244	24.85	25.06	24.89	21.63	22.53	21.48	24.70	24.63	24.68	21.03	20.65	20.31
		120	60	27.11	27.14	27.47	24.59	25.11	24.38	27.53	27.87	26.51	23.91	23.55	22.96
		243	0	26.54	26.49	26.90	24.13	24.39	23.06	26.41	26.74	25.55	22.83	22.54	21.90
	64QAM	1	0	24.67	24.61	25.20	23.12	22.27	21.42	25.28	25.46	24.38	21.02	20.62	20.16
		1	1	25.59	25.10	25.76	23.80	23.23	22.13	26.22	26.54	25.89	22.20	21.92	21.12
		1	243	26.16	25.98	25.90	23.13	23.40	22.61	25.60	24.90	25.78	21.90	21.17	21.00
		1	244	25.19	25.17	24.56	22.05	22.76	21.46	24.51	24.62	24.34	21.21	20.12	20.36
		120	60	25.61	25.74	26.09	23.05	23.93	22.90	25.97	26.33	24.99	22.43	22.11	21.41
		243	0	25.83	25.99	26.34	23.65	23.84	22.54	25.99	26.21	25.06	22.41	22.06	21.51
	256QAM	1	0	23.57	23.41	24.08	22.18	21.89	20.87	24.30	24.21	23.29	20.21	20.13	19.94
		1	1	23.69	23.18	24.11	22.45	21.82	21.23	24.17	24.03	23.30	20.18	20.49	19.57
		1	243	24.39	24.41	23.80	21.05	21.63	20.59	23.52	23.73	23.44	20.16	19.16	18.87
		1	244	23.87	23.82	23.64	20.97	21.92	20.92	23.38	23.40	23.21	20.11	19.54	19.22
		120	60	23.74	24.04	24.41	21.42	21.91	20.80	23.93	24.40	22.99	20.39	20.05	19.40
		243	0	23.82	24.00	24.34	21.61	21.84	20.50	23.87	24.24	23.03	20.34	20.01	19.41

OUTPUT POWER FOR 5G NR n77 (100.0 MHz)

Bandwidth (MHz)	Modulation	RB Allocation	RB Offset	Conducted Average (dBm)											
				ANT 7			ANT 8			ANT 9			ANT 4		
				650000	656000	662000	650000	656000	662000	650000	656000	662000	650000	656000	662000
100.0	BPSK	1	0	24.57	24.59	25.25	22.72	21.93	22.17	24.90	24.63	24.74	21.52	21.39	20.75
		1	1	27.62	27.70	28.46	25.27	24.43	24.69	28.10	28.01	27.58	24.45	24.34	24.06
		1	271	28.18	28.46	28.42	24.09	24.86	24.17	27.74	27.85	27.75	24.60	23.79	23.83
		1	272	24.95	25.30	25.42	21.46	22.31	21.61	24.43	24.55	24.33	21.44	20.62	20.48
		135	67	28.09	28.32	28.70	24.71	25.26	24.18	27.90	28.69	27.33	24.65	24.31	23.71
		270	0	27.94	28.08	28.43	24.88	25.11	23.91	27.75	28.27	27.08	24.33	24.07	23.52
	QPSK	1	0	24.59	24.49	25.25	22.86	22.13	22.11	24.87	24.82	24.57	21.32	21.33	20.67
		1	1	27.62	27.74	28.04	25.55	24.55	24.55	28.09	27.95	27.63	24.44	24.57	23.88
		1	271	28.36	28.28	28.48	24.16	24.89	24.24	27.82	27.29	27.46	24.61	23.79	23.76
		1	272	24.93	25.35	25.22	21.63	22.38	21.52	24.51	24.55	24.34	21.40	20.59	20.54
		135	67	27.98	28.02	28.41	24.77	25.20	24.19	27.95	28.70	27.22	24.70	24.31	23.63
		270	0	27.41	27.55	27.91	24.87	25.12	23.90	27.25	27.65	26.57	23.84	23.59	23.01
	16QAM	1	0	24.25	24.78	25.19	22.95	22.11	22.24	25.29	25.23	23.74	20.88	21.68	20.39
		1	1	27.37	26.81	27.35	25.70	24.39	24.60	27.31	27.39	26.90	23.85	23.69	23.18
		1	271	27.44	27.86	27.69	23.99	24.94	24.13	26.93	25.98	27.02	23.80	23.17	22.94
		1	272	24.99	24.99	25.23	21.42	21.93	21.59	23.99	23.81	24.70	21.24	20.91	20.59
		135	67	26.97	27.03	27.33	24.63	25.27	24.15	27.17	27.91	26.56	23.81	23.61	23.01
		270	0	26.36	26.51	26.91	23.88	24.16	22.91	26.14	26.66	25.61	22.84	22.55	22.00
	64QAM	1	0	24.30	24.67	25.03	22.97	21.94	22.07	25.04	25.33	25.26	20.70	21.37	20.19
		1	1	25.52	25.41	25.69	23.98	22.67	22.63	26.04	26.31	25.29	22.00	22.14	21.39
		1	271	25.67	25.69	25.92	22.29	23.26	22.32	25.97	25.21	25.36	22.36	21.86	20.75
		1	272	24.94	24.98	25.18	21.40	22.53	21.88	24.48	24.51	24.95	21.16	20.11	20.66
		135	67	25.68	25.64	26.08	23.09	23.71	22.62	25.58	26.37	25.05	22.46	22.12	21.47
		270	0	25.85	26.03	26.32	23.32	23.68	22.40	25.69	26.16	25.02	22.37	22.05	21.52
	256QAM	1	0	23.22	23.24	24.34	22.15	21.20	21.42	24.14	24.05	23.41	19.92	19.99	19.57
		1	1	23.30	23.10	24.23	22.25	21.15	21.17	23.74	23.73	23.57	20.32	20.63	19.77
		1	271	23.70	24.16	23.88	20.74	21.83	20.95	23.61	23.77	23.28	20.41	19.39	19.41
		1	272	23.56	24.44	24.12	20.91	21.03	21.16	23.72	23.13	23.19	20.60	19.47	19.54
		135	67	23.78	24.05	24.47	21.23	21.68	20.57	23.64	24.34	22.93	20.45	20.10	19.40
		270	0	23.77	24.03	24.29	21.45	21.69	20.42	23.89	24.19	22.98	20.39	20.01	19.46

9. CONDUCTED TEST RESULTS

9.1. OCCUPIED BANDWIDTH

RULE PART(S)

FCC: §2.1049

LIMITS

For reporting purposes only.

TEST PROCEDURE

The transmitter output was connected to a calibrated coaxial cable and coupler, the other end of which was connected to a spectrum analyzer. The occupied bandwidth was measured with the spectrum analyzer at the middle channel in each band. The 99% and -26dB bandwidths was also measured and recorded.

RESULTS

There is no limit required and power is the same for low, middle and high channel; therefore, only middle channel was tested except 5G NR n70 where mix of middle/high channels are used. Worst-case plots (highest bandwidth) are reported only.

LTE BAND 7

Band	Mode	RB Allocation/RB Offset	f(MHz)	99% BW (MHz)	-26dB BW (MHz)
LTE BAND 7	5MHz, QPSK	25/0	2535.0	4.505	5.087
	5MHz, 16QAM			4.504	5.18
	10MHz, QPSK	50/0		8.992	9.935
	10MHz, 16QAM			9.003	9.97
	15MHz, QPSK	75/0		13.454	14.75
	15MHz, 16QAM			13.436	14.82
	20MHz, QPSK	100/0		17.869	18.74
	20MHz, 16QAM			17.924	19.73
	20MHz, QPSK	1/0		0.278	0.435

5G NR n7

Band	Mode	RB Allocation/RB Offset	f(MHz)	99% BW (MHz)	-26dB BW (MHz)
5G NR n7	5MHz, BPSK	25/0	2535.0	4.494	5.069
	5MHz, QPSK			4.476	4.99
	5MHz, 16QAM			4.480	5.01
	10MHz, BPSK	50/0		8.976	9.733
	10MHz, QPSK			8.978	9.93
	10MHz, 16QAM			8.971	9.81
	15MHz, BPSK	75/0		13.400	14.36
	15MHz, QPSK			13.433	14.40
	15MHz, 16QAM			13.395	14.28
	20MHz, BPSK	100/0		17.922	18.91
	20MHz, QPSK			17.883	18.99
	20MHz, 16QAM			17.897	19.04
	25MHz, BPSK	128/0		22.927	24.19
	25MHz, QPSK			22.978	24.10
	25MHz, 16QAM			22.923	24.23
	30MHz, BPSK	160/0		28.627	30.08
	30MHz, QPSK			28.534	30.02
	30MHz, 16QAM			28.597	30.06
	35MHz, BPSK	180/0		32.112	33.77
	35MHz, QPSK			32.089	33.72
	35MHz, 16QAM			32.190	33.67
	40MHz, BPSK	216/0		38.609	40.30
	40MHz, QPSK			38.588	40.52
	40MHz, 16QAM			38.480	40.36
40MHz, BPSK	1/0		0.287	0.468	

LTE BAND 12

Band	Mode	RB Allocation/RB Offset	f(MHz)	99% BW (MHz)	-26dB BW (MHz)
LTE BAND 12	1.4MHz, QPSK	6/0	707.5	1.094	1.366
	1.4MHz, 16QAM			1.095	1.37
	3MHz, QPSK	15/0		2.701	3.047
	3MHz, 16QAM			2.705	3.02
	5MHz, QPSK	25/0		4.501	5.111
	5MHz, 16QAM			4.496	5.13
	10MHz, QPSK	50/0		8.969	9.969
	10MHz, 16QAM			8.975	9.96
	10MHz, QPSK	1/0		0.259	0.409

5G NR n12

Band	Mode	RB Allocation/RB Offset	f(MHz)	99% BW (MHz)	-26dB BW (MHz)
5G NR n12	5MHz, BPSK	25/0	707.5	4.502	4.992
	5MHz, QPSK			4.457	4.95
	5MHz, 16QAM			4.486	5.11
	10MHz, BPSK	50/0		8.940	9.666
	10MHz, QPSK			8.955	9.67
	10MHz, 16QAM			8.924	9.70
	15MHz, BPSK	75/0		13.415	14.45
	15MHz, QPSK			13.337	14.43
	15MHz, 16QAM			13.432	14.24
	15MHz, BPSK	1/0		0.244	0.395

LTE BAND 13

Band	Mode	RB Allocation/RB Offset	f(MHz)	99% BW (MHz)	-26dB BW (MHz)
LTE BAND 13	5MHz, QPSK	25/0	782.0	4.507	5.168
	5MHz, 16QAM			4.504	5.12
	10MHz, QPSK	50/0		8.983	9.894
	10MHz, 16QAM			8.976	9.93
	10MHz, QPSK	1/0		0.249	0.405

LTE BAND 14

Band	Mode	RB Allocation/RB Offset	f(MHz)	99% BW (MHz)	-26dB BW (MHz)
LTE BAND 14	5MHz, QPSK	25/0	793.0	4.507	5.085
	5MHz, 16QAM			4.501	5.06
	10MHz, QPSK	50/0		8.976	9.919
	10MHz, 16QAM			8.953	9.93
	10MHz, QPSK	1/0		0.249	0.405

5G NR n14

Band	Mode	RB Allocation/RB Offset	f(MHz)	99% BW (MHz)	-26dB BW (MHz)
5G NR n14	5MHz, BPSK	25/0	793.0	4.487	5.055
	5MHz, QPSK			4.492	4.99
	5MHz, 16QAM			4.476	5.06
	10MHz, BPSK	50/0		8.960	9.657
	10MHz, QPSK			8.933	9.76
	10MHz, 16QAM			8.920	9.70
	10MHz, BPSK	1/0		0.241	0.406

LTE BAND 17

Band	Mode	RB Allocation/RB Offset	f(MHz)	99% BW (MHz)	-26dB BW (MHz)
LTE BAND 17	5MHz, QPSK	25/0	710.0	4.495	5.115
	5MHz, 16QAM			4.500	5.13
	10MHz, QPSK	50/0		8.966	10.02
	10MHz, 16QAM			8.968	9.94
	10MHz, QPSK			0.248	0.402

LTE BAND 25

Band	Mode	RB Allocation/RB Offset	f(MHz)	99% BW (MHz)	-26dB BW (MHz)
LTE BAND 25	1.4MHz, QPSK	6/0	1882.5	1.095	1.347
	1.4MHz, 16QAM			1.095	1.36
	3MHz, QPSK	15/0		2.702	3.047
	3MHz, 16QAM			2.708	3.04
	5MHz, QPSK	25/0		4.509	5.054
	5MHz, 16QAM			4.504	5.17
	10MHz, QPSK	50/0		8.986	9.994
	10MHz, 16QAM			8.994	10.05
	15MHz, QPSK	75/0		13.475	14.78
	15MHz, 16QAM			13.487	14.84
	20MHz, QPSK	100/0		17.937	19.69
	20MHz, 16QAM			17.947	19.74
	20MHz, QPSK	1/0		0.280	0.480

5G NR n25

Band	Mode	RB Allocation/RB Offset	f(MHz)	99% BW (MHz)	-26dB BW (MHz)
5G NR n25	5MHz, BPSK	25/0	1882.5	4.492	5.151
	5MHz, QPSK			4.482	5.04
	5MHz, 16QAM			4.497	5.10
	10MHz, BPSK	50/0		8.962	9.804
	10MHz, QPSK			8.983	9.83
	10MHz, 16QAM			8.934	9.67
	15MHz, BPSK	75/0		13.427	14.34
	15MHz, QPSK			13.417	14.4
	15MHz, 16QAM			13.462	14.37
	20MHz, BPSK	100/0		17.881	18.97
	20MHz, QPSK			17.879	18.99
	20MHz, 16QAM			17.874	19.00
	25MHz, BPSK	128/0		22.911	24.19
	25MHz, QPSK			22.962	24.26
	25MHz, 16QAM			22.872	24.27
	30MHz, BPSK	160/0		28.650	30.19
	30MHz, QPSK			28.573	30.11
	30MHz, 16QAM			28.591	30.09
	35MHz, BPSK	180/0		32.252	33.90
	35MHz, QPSK			32.216	33.65
35MHz, 16QAM	32.143		33.75		
40MHz, BPSK	216/0	38.548	40.32		
40MHz, QPSK		38.578	40.52		
40MHz, 16QAM		38.625	40.34		
40MHz, BPSK	1/0	0.274	0.477		

LTE BAND 26(FCC PART 90S)

Band	Mode	RB Allocation/RB Offset	f(MHz)	99% BW (MHz)	-26dB BW (MHz)
LTE BAND 26	1.4MHz, QPSK	6/0	819.0	1.092	1.315
	1.4MHz, 16QAM			1.098	1.37
	3MHz, QPSK	15/0		2.703	3.077
	3MHz, 16QAM			2.711	3.07
	5MHz, QPSK	25/0		4.510	5.080
	5MHz, 16QAM			4.512	5.17
	10MHz, QPSK	50/0		8.974	9.965
	10MHz, 16QAM			8.982	10.02
	10MHz, QPSK	1/0		0.262	0.449

5G NR n26 (FCC PART 90S)

Band	Mode	RB Allocation/RB Offset	f(MHz)	99% BW (MHz)	-26dB BW (MHz)
5G NR n26 (Part 90S)	5MHz, BPSK	25/0	819.0	4.467	5.062
	5MHz, QPSK			4.485	5.02
	5MHz, 16QAM			4.491	5.07
	10MHz, BPSK	50/0		8.989	9.781
	10MHz, QPSK			8.969	9.76
	10MHz, 16QAM			8.948	9.67
	10MHz, BPSK	1/0		0.222	0.353

LTE BAND 26 (FCC PART 22)

Band	Mode	RB Allocation/RB Offset	f(MHz)	99% BW (MHz)	-26dB BW (MHz)
LTE BAND 26	1.4MHz, QPSK	6/0	836.5	1.095	1.323
	1.4MHz, 16QAM			1.096	1.36
	3MHz, QPSK	15/0		2.702	3.056
	3MHz, 16QAM			2.705	3.06
	5MHz, QPSK	25/0		4.500	5.089
	5MHz, 16QAM			4.502	5.16
	10MHz, QPSK	50/0		8.988	9.879
	10MHz, 16QAM			8.975	9.86
	10MHz, QPSK	1/0		0.247	0.395

5G NR n26 (FCC PART 22)

Band	Mode	RB Allocation/RB Offset	f(MHz)	99% BW (MHz)	-26dB BW (MHz)
5G NR n26 (FCC Part 22)	5MHz, BPSK	25/0	836.5	4.456	4.935
	5MHz, QPSK			4.483	5.09
	5MHz, 16QAM			4.472	4.99
	10MHz, BPSK	50/0		8.939	9.652
	10MHz, QPSK			8.981	9.78
	10MHz, 16QAM			8.972	9.71
	15MHz, BPSK	75/0		13.396	14.07
	15MHz, QPSK			13.421	14.34
	15MHz, 16QAM			13.395	14.32
	20MHz, BPSK	100/0		17.844	18.97
	20MHz, QPSK			17.894	19.06
	20MHz, 16QAM			17.860	19.01
	20MHz, BPSK			0.257	0.475

LTE BAND 30

Band	Mode	RB Allocation/RB Offset	f(MHz)	99% BW (MHz)	-26dB BW (MHz)
LTE BAND 30	5MHz, QPSK	25/0	2310.0	4.505	5.127
	5MHz, 16QAM			4.512	5.117
	10MHz, QPSK	50/0		8.995	9.957
	10MHz, 16QAM			8.995	9.90
	10MHz, QPSK	1/0		0.246	0.417

5G NR n30

Band	Mode	RB Allocation/RB Offset	f(MHz)	99% BW (MHz)	-26dB BW (MHz)
5G NR n30	5MHz, BPSK	25/0	2310.0	4.492	5.154
	5MHz, QPSK			4.485	5.15
	5MHz, 16QAM			4.479	4.97
	10MHz, BPSK	50/0		8.977	9.795
	10MHz, QPSK			8.992	9.75
	10MHz, 16QAM			8.941	9.68
	10MHz, BPSK			1/0	0.240

LTE BAND 41

Band	Mode	RB Allocation/RB Offset	f(MHz)	99% BW (MHz)	-26dB BW (MHz)
LTE BAND 41	5MHz, QPSK	25/0	2593.0	4.487	5.030
	5MHz, 16QAM			4.484	5.12
	10MHz, QPSK	50/0		8.974	9.877
	10MHz, 16QAM			8.966	9.78
	15MHz, QPSK	75/0		13.474	14.70
	15MHz, 16QAM			13.453	14.73
	20MHz, QPSK	100/0		17.950	19.43
	20MHz, 16QAM			17.933	19.36
	20MHz, QPSK	1/0		0.271	0.407

5G NR n41

Band	Mode	RB Allocation/RB Offset	f(MHz)	99% BW (MHz)	-26dB BW (MHz)
5G NR n41 (FCC)	10MHz, BPSK	24/0	2593.0	8.616	9.394
	10MHz, QPSK			8.570	9.77
	10MHz, 16QAM			8.635	9.81
	15MHz, BPSK	36/0		12.925	14.41
	15MHz, QPSK			12.864	14.54
	15MHz, 16QAM			12.912	14.28
	20MHz, BPSK	50/0		17.886	19.70
	20MHz, QPSK			17.922	19.71
	20MHz, 16QAM			17.919	19.68
	30MHz, BPSK	75/0		26.835	28.73
	30MHz, QPSK			26.826	28.74
	30MHz, 16QAM			26.868	28.94
	40MHz, BPSK	100/0		35.808	38.07
	40MHz, QPSK			35.685	37.87
	40MHz, 16QAM			35.703	37.93
	50MHz, BPSK	128/0		45.574	48.29
	50MHz, QPSK			45.761	48.57
	50MHz, 16QAM			45.765	48.02
	60MHz, BPSK	162/0		57.884	60.80
	60MHz, QPSK			58.028	61.03
	60MHz, 16QAM			57.834	60.75
	70MHz, BPSK	180/0		64.425	67.66
	70MHz, QPSK			64.529	67.80
	70MHz, 16QAM			64.451	67.47
	80MHz, BPSK	216/0		77.108	80.77
	80MHz, QPSK			77.372	80.69
	80MHz, 16QAM			77.157	80.84
	90MHz, BPSK	243/0		86.766	90.81
	90MHz, QPSK			86.817	90.80
	90MHz, 16QAM			87.077	90.50
100MHz, BPSK	270/0	96.682	100.9		
100MHz, QPSK		96.648	100.9		
100MHz, 16QAM		96.848	101.1		
100MHz, BPSK	1/0	0.597	1.034		

LTE BAND 66

Band	Mode	RB Allocation/RB Offset	f(MHz)	99% BW (MHz)	-26dB BW (MHz)
LTE BAND 66	1.4MHz, QPSK	6/0	1745.0	1.096	1.368
	1.4MHz, 16QAM			1.093	1.38
	3MHz, QPSK	15/0		2.700	3.069
	3MHz, 16QAM			2.701	3.04
	5MHz, QPSK	25/0		4.518	5.154
	5MHz, 16QAM			4.503	5.13
	10MHz, QPSK	50/0		8.986	10.02
	10MHz, 16QAM			8.988	9.95
	15MHz, QPSK	75/0		13.446	14.77
	15MHz, 16QAM			13.457	14.84
	20MHz, QPSK	100/0		17.927	19.64
	20MHz, 16QAM			17.926	19.52
	20MHz, QPSK	1/0		0.272	0.450

5G NR n66

Band	Mode	RB Allocation/RB Offset	f(MHz)	99% BW (MHz)	-26dB BW (MHz)
5G NR n66	5MHz, BPSK	25/0	1745.0	4.509	5.183
	5MHz, QPSK			4.516	5.21
	5MHz, 16QAM			4.470	5.03
	10MHz, BPSK	50/0		8.935	9.673
	10MHz, QPSK			8.970	9.83
	10MHz, 16QAM			8.992	9.79
	15MHz, BPSK	75/0		13.489	14.32
	15MHz, QPSK			13.457	14.4
	15MHz, 16QAM			13.467	14.37
	20MHz, BPSK	100/0		17.922	19.11
	20MHz, QPSK			17.911	18.98
	20MHz, 16QAM			17.827	18.87
	25MHz, BPSK	128/0		22.903	24.17
	25MHz, QPSK			22.869	24.08
	25MHz, 16QAM			22.866	24.19
	30MHz, BPSK	160/0		28.590	30.06
	30MHz, QPSK			28.574	30.15
	30MHz, 16QAM			28.600	30.07
	35MHz, BPSK	180/0		32.255	33.78
	35MHz, QPSK			32.243	33.68
	35MHz, 16QAM			32.144	33.74
	40MHz, BPSK	216/0		38.641	40.37
	40MHz, QPSK			38.618	40.33
	40MHz, 16QAM			38.604	40.43
40MHz, BPSK	1/0	0.280	0.499		

5G NR n70

Band	Mode	RB Allocation/RB Offset	f(MHz)	99% BW (MHz)	-26dB BW (MHz)
5G NR n70	5MHz, BPSK	25/0	1702.5	4.505	5.166
	5MHz, QPSK			4.506	5.155
	5MHz, 16QAM			4.489	5.069
	10MHz, BPSK	50/0		8.965	9.898
	10MHz, QPSK			8.978	9.65
	10MHz, 16QAM			8.969	9.77
	15MHz, BPSK	75/0		13.433	14.41
	15MHz, QPSK			13.410	14.39
	15MHz, 16QAM			13.423	14.36
	15MHz, BPSK	1/0		0.243	0.378

LTE BAND 71

Band	Mode	RB Allocation/RB Offset	f(MHz)	99% BW (MHz)	-26dB BW (MHz)
LTE BAND 71	5MHz, QPSK	25/0	680.5	4.505	5.105
	5MHz, 16QAM			4.499	5.14
	10MHz, QPSK	50/0		8.953	10.06
	10MHz, 16QAM			8.967	9.960
	15MHz, QPSK	75/0		13.422	14.72
	15MHz, 16QAM			13.420	14.81
	20MHz, QPSK	100/0		17.880	19.60
	20MHz, 16QAM			17.888	19.45
	20MHz, QPSK			0.260	0.408

5G NR n71

Band	Mode	RB Allocation/RB Offset	f(MHz)	99% BW (MHz)	-26dB BW (MHz)
5G NR n71	5MHz, BPSK	25/0	680.5	4.457	4.982
	5MHz, QPSK			4.491	4.95
	5MHz, 16QAM			4.487	5.10
	10MHz, BPSK	50/0		8.964	9.819
	10MHz, QPSK			8.967	9.76
	10MHz, 16QAM			8.946	9.67
	15MHz, BPSK	75/0		13.385	14.30
	15MHz, QPSK			13.422	14.47
	15MHz, 16QAM			13.383	14.3
	20MHz, BPSK	100/0		17.889	19.13
	20MHz, QPSK			17.843	19.03
	20MHz, 16QAM			17.818	19.05
	20MHz, BPSK			0.260	0.466

5G NR n77(FCC Part 27 3450-3550MHz)

Band	Mode	RB Allocation/RB Offset	f(MHz)	99% BW (MHz)	-26dB BW (MHz)
5G NR n77 (FCC Part 27 3450- 3550MHz)	10MHz, BPSK	24/0	3500.0	8.631	9.967
	10MHz, QPSK			8.628	9.97
	10MHz, 16QAM			8.647	9.86
	15MHz, BPSK	36/0		12.907	14.00
	15MHz, QPSK			12.892	14.24
	15MHz, 16QAM			12.910	14.26
	20MHz, BPSK	50/0		17.866	19.41
	20MHz, QPSK			17.912	19.62
	20MHz, 16QAM			17.954	19.64
	30MHz, BPSK	75/0		26.798	28.80
	30MHz, QPSK			26.799	28.77
	30MHz, 16QAM			26.816	28.83
	40MHz, BPSK	100/0		35.681	38.16
	40MHz, QPSK			35.801	38.01
	40MHz, 16QAM			35.803	38.13
	50MHz, BPSK	128/0		45.745	48.52
	50MHz, QPSK			45.662	48.37
	50MHz, 16QAM			45.826	48.47
	60MHz, BPSK	162/0		57.845	60.71
	60MHz, QPSK			57.901	60.74
	60MHz, 16QAM			57.934	60.70
	70MHz, BPSK	180/0		64.320	67.67
	70MHz, QPSK			64.337	67.67
	70MHz, 16QAM			64.267	67.48
	80MHz, BPSK	216/0		77.239	80.57
	80MHz, QPSK			77.076	80.63
	80MHz, 16QAM			77.097	80.50
	90MHz, BPSK	243/0		86.900	90.46
	90MHz, QPSK			86.696	90.56
	90MHz, 16QAM			86.757	90.74
100MHz, BPSK	270/0	96.340	100.7		
100MHz, QPSK		96.530	100.7		
100MHz, 16QAM		96.535	100.8		
100MHz, BPSK	1/0	0.597	1.054		

5G NR n77(FCC Part 27 3700-3980MHz)

Band	Mode	RB Allocation/RB Offset	f(MHz)	99% BW (MHz)	-26dB BW (MHz)
5G NR n77 (FCC Part 27 3700- 3980MHz)	10MHz, BPSK	24/0	3840.0	8.624	9.850
	10MHz, QPSK			8.603	9.46
	10MHz, 16QAM			8.637	9.89
	15MHz, BPSK	36/0		12.886	13.85
	15MHz, QPSK			12.920	14.03
	15MHz, 16QAM			12.896	14.41
	20MHz, BPSK	50/0		17.910	19.43
	20MHz, QPSK			17.809	19.03
	20MHz, 16QAM			17.927	19.18
	30MHz, BPSK	75/0		26.756	28.22
	30MHz, QPSK			26.979	28.61
	30MHz, 16QAM			26.885	28.80
	40MHz, BPSK	100/0		35.711	37.72
	40MHz, QPSK			35.764	37.92
	40MHz, 16QAM			35.640	37.38
	50MHz, BPSK	128/0		45.852	47.67
	50MHz, QPSK			45.778	48.00
	50MHz, 16QAM			45.675	47.82
	60MHz, BPSK	162/0		57.976	60.26
	60MHz, QPSK			57.943	60.31
	60MHz, 16QAM			57.983	60.37
	70MHz, BPSK	180/0		64.370	67.50
	70MHz, QPSK			64.347	67.32
	70MHz, 16QAM			64.557	67.20
	80MHz, BPSK	216/0		77.243	80.62
	80MHz, QPSK			77.058	80.44
	80MHz, 16QAM			77.164	80.65
	90MHz, BPSK	243/0		86.741	90.12
90MHz, QPSK	86.882		90.36		
90MHz, 16QAM	86.690		90.43		
100MHz, BPSK	270/0	96.453	100.5		
100MHz, QPSK		96.283	100.4		
100MHz, 16QAM		96.387	100.4		
100MHz, BPSK	1/0	0.596	1.054		

9.1.1. LTE BAND 7 AND 5G NR n7

LTE BAND 7

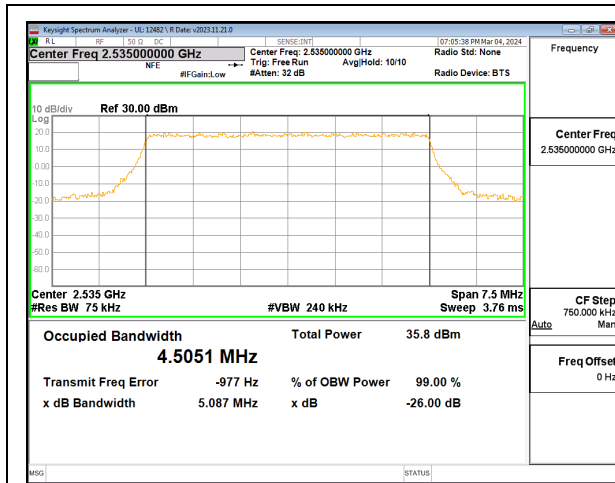

LTE B7 5MHz QPSK Middle Channel RB25-0

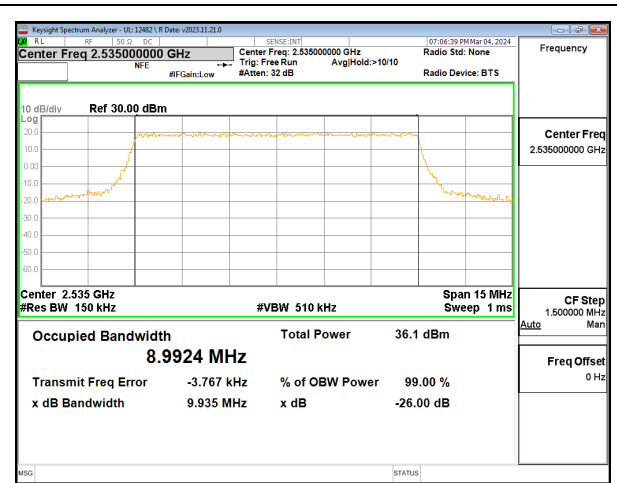

LTE B7 10MHz QPSK Middle Channel RB50-0

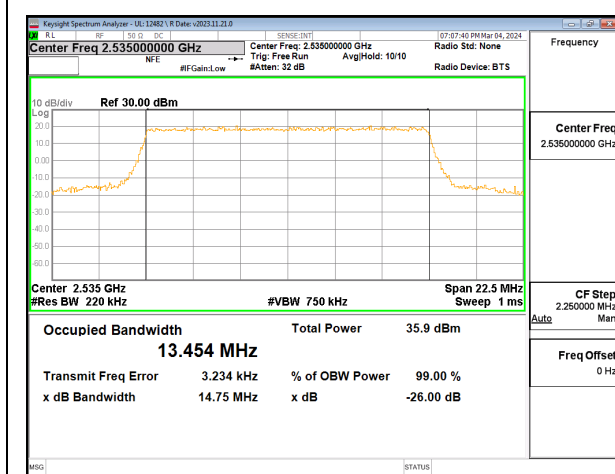

LTE B7 15MHz QPSK Middle Channel RB75-0

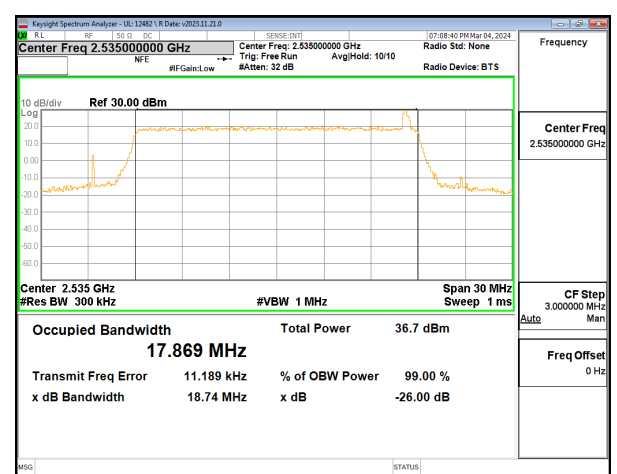

LTE B7 20MHz QPSK Middle Channel RB100-0

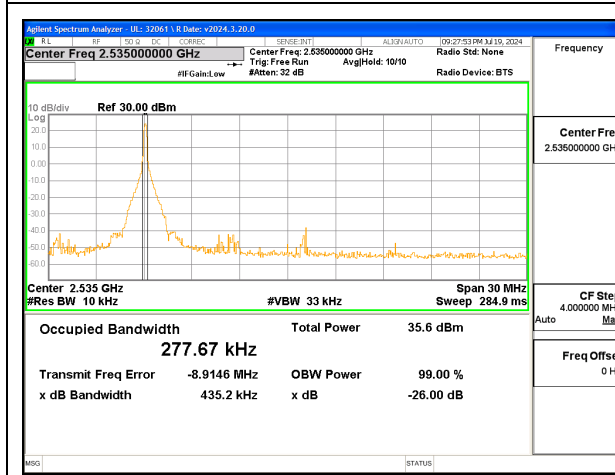

LTE B7 20MHz QPSK Middle Channel RB1-0

Intentionally Blank

5G NR n7

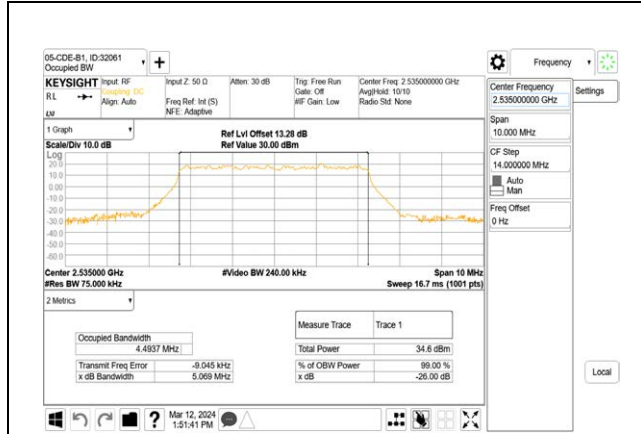

5G NR n7 5MHz BPSK Middle Channel RB25-0

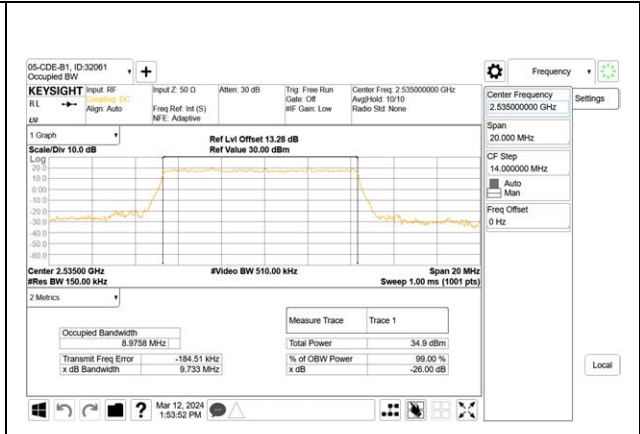

5G NR n7 10MHz BPSK Middle Channel RB50-0

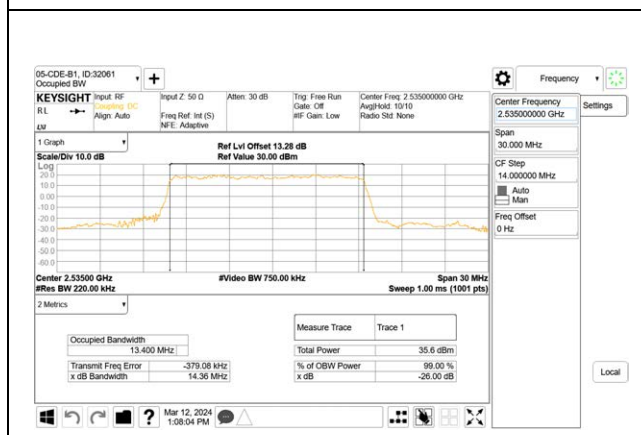

5G NR n7 15MHz BPSK Middle Channel RB75-0

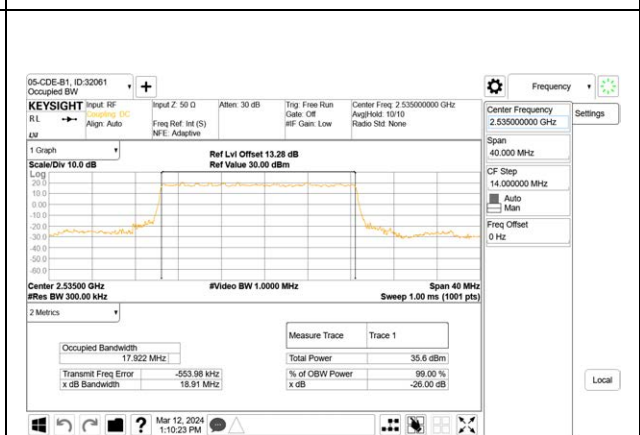

5G NR n7 20MHz BPSK Middle Channel RB100-0

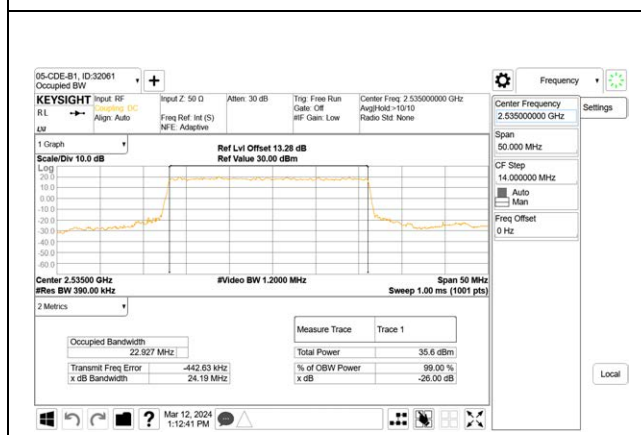

5G NR n7 25MHz BPSK Middle Channel RB128-0

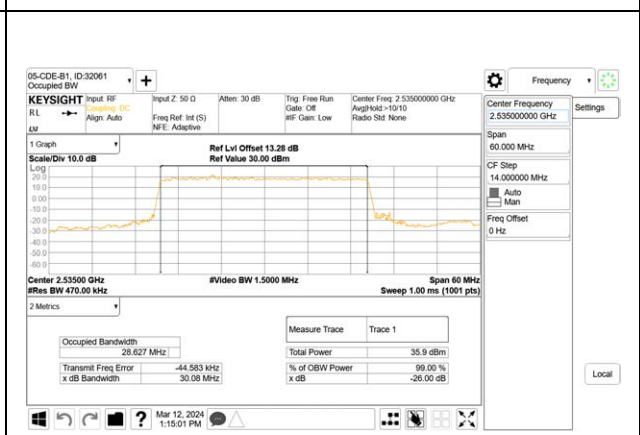

5G NR n7 30MHz BPSK Middle Channel RB160-0

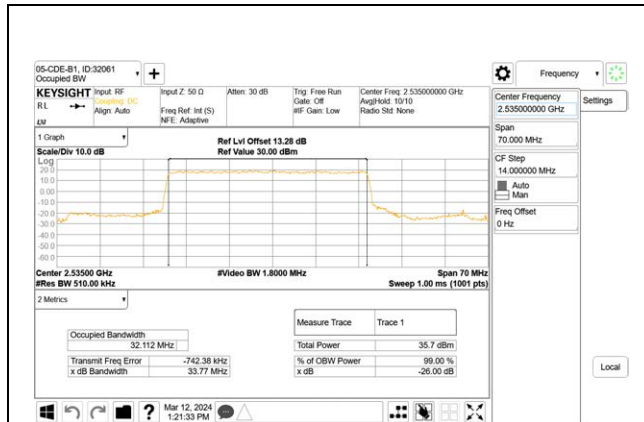

5G NR n7 35MHz BPSK Middle Channel RB180-0

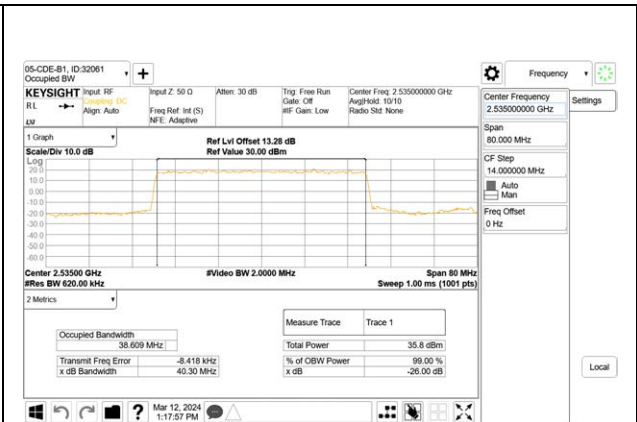

5G NR n7 40MHz BPSK Middle Channel RB216-0

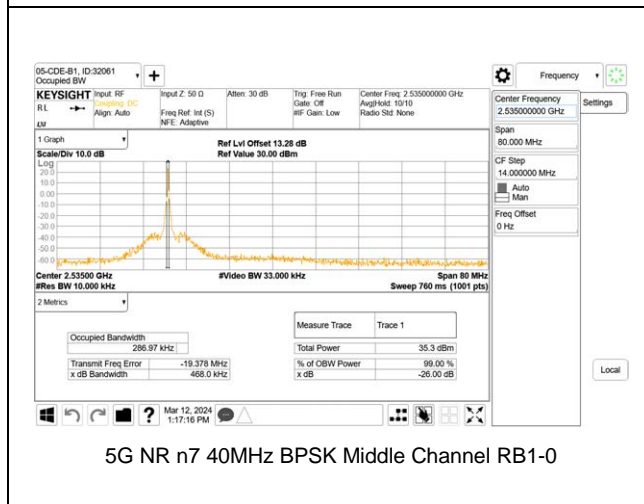

5G NR n7 40MHz BPSK Middle Channel RB1-0

9.1.2. LTE BAND 12 AND 5G NR n12

LTE BAND 12

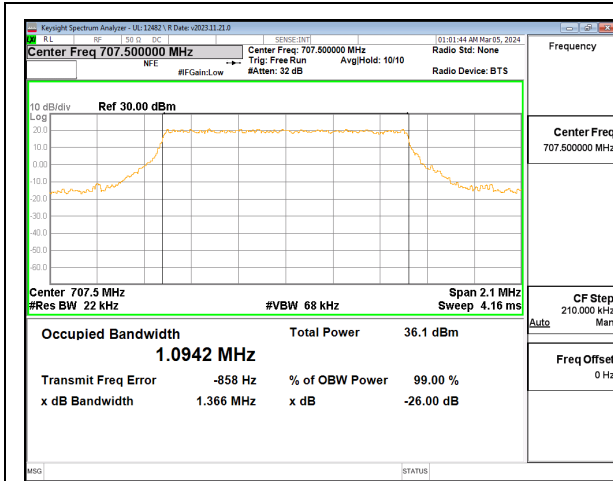

LTE B12 1.4MHz QPSK Middle Channel RB6-0

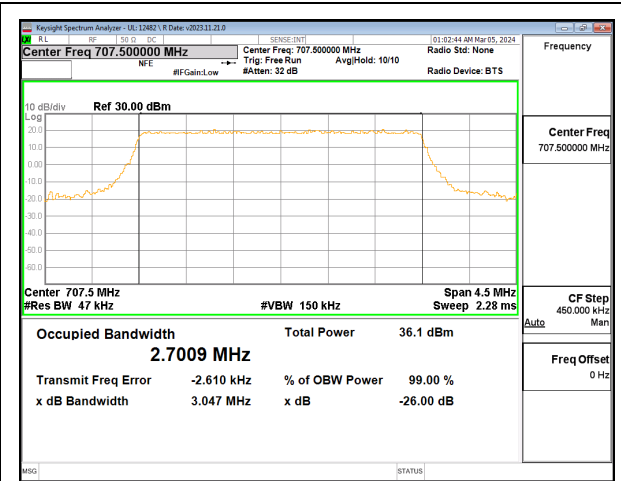

LTE B12 3MHz QPSK Middle Channel RB15-0

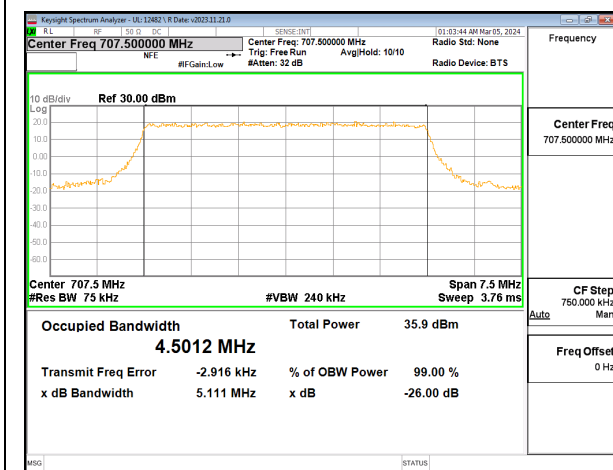

LTE B12 5MHz QPSK Middle Channel RB25-0

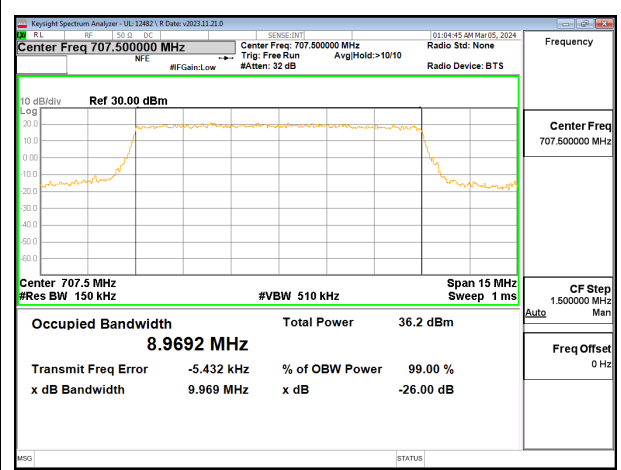

LTE B12 10MHz QPSK Middle Channel RB50-0

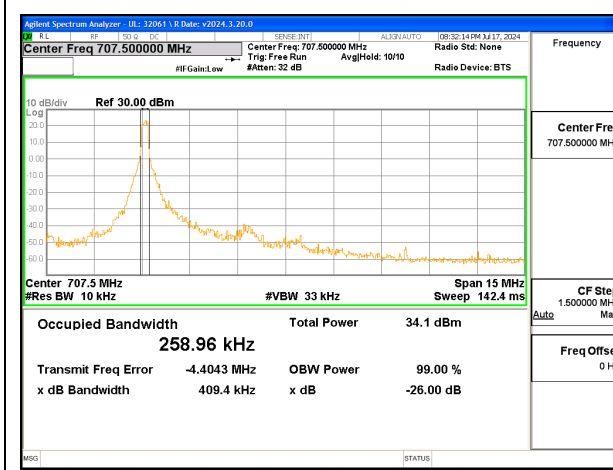

LTE B12 10MHz QPSK Middle Channel RB1-0

Intentionally Blank

5G NR n12

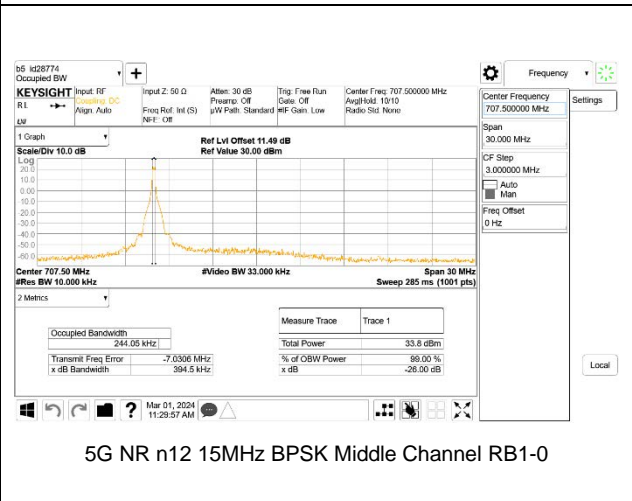
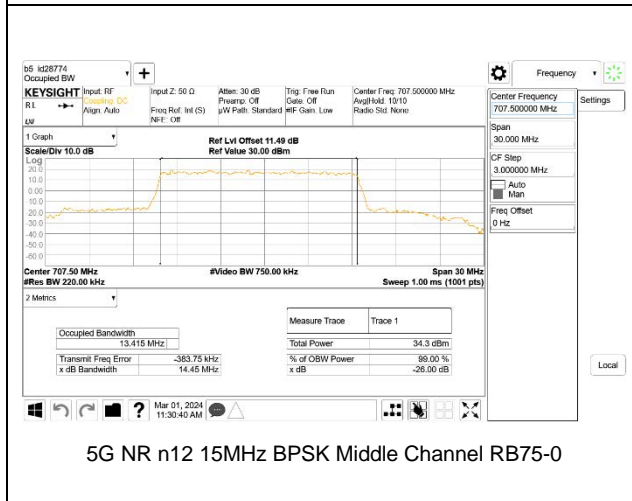
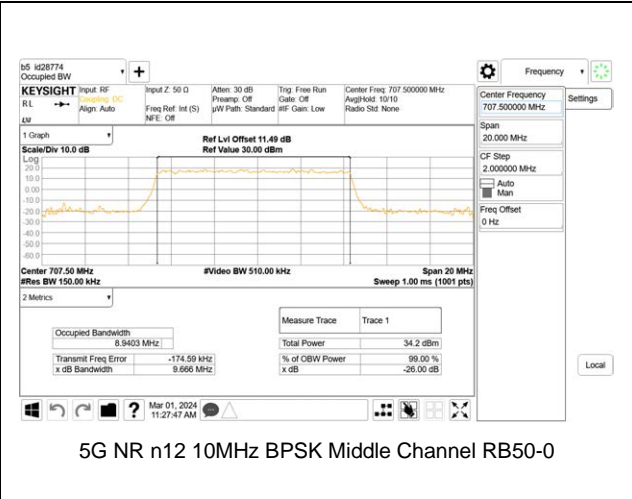
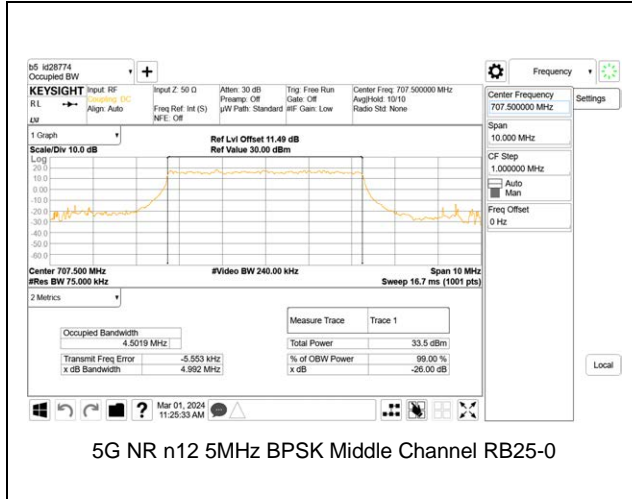

9.1.3. LTE BAND 13

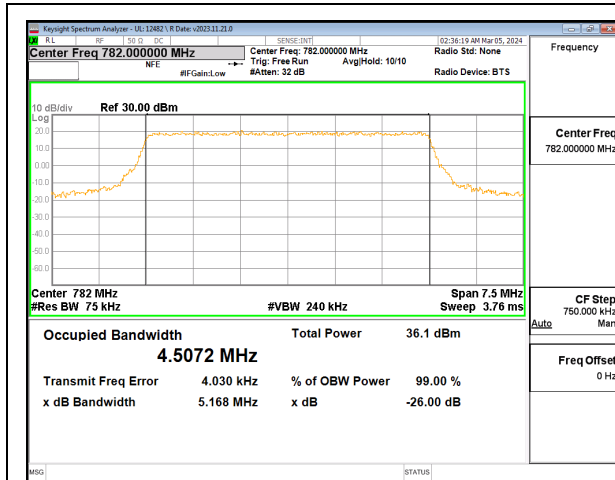

LTE B13 5MHz QPSK Middle Channel RB25-0

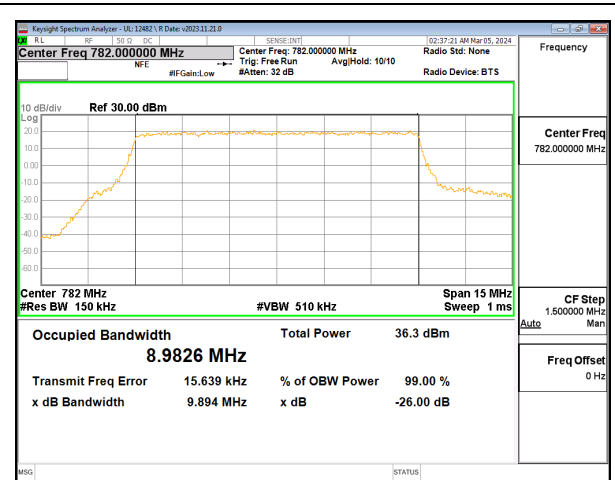

LTE B13 10MHz QPSK Middle Channel RB50-0

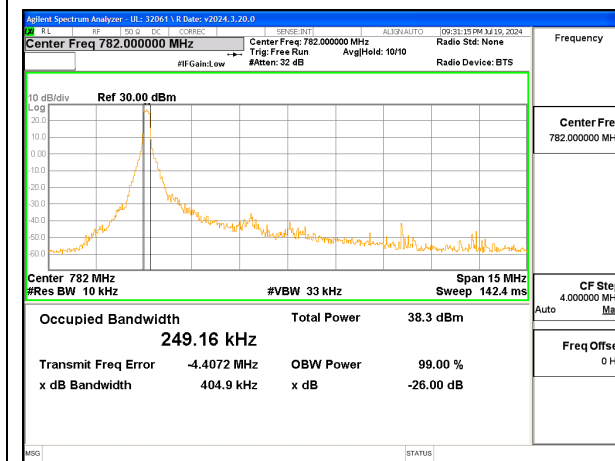

LTE B13 10MHz QPSK Middle Channel RB1-0

Intentionally Blank

9.1.4. LTE BAND 14 AND 5G NR n14

LTE BAND 14

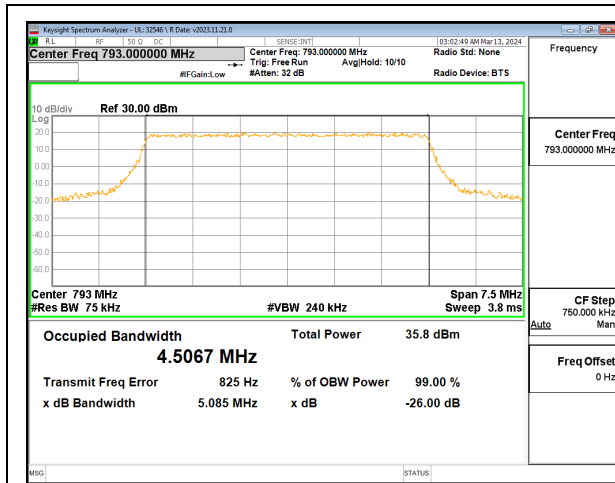

LTE B14 5MHz QPSK Middle Channel RB25-0

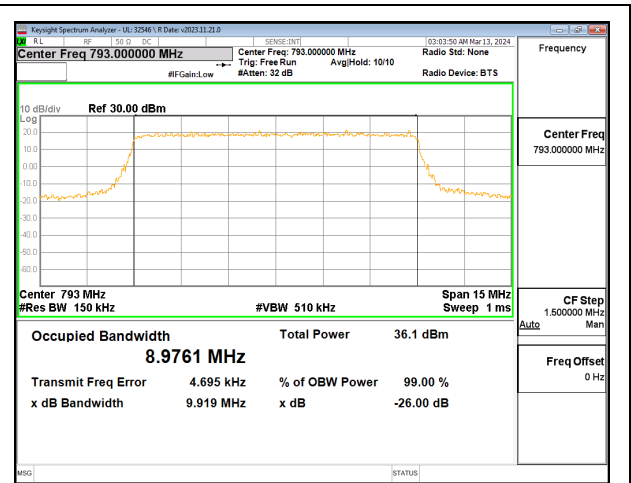

LTE B14 10MHz QPSK Middle Channel RB50-0

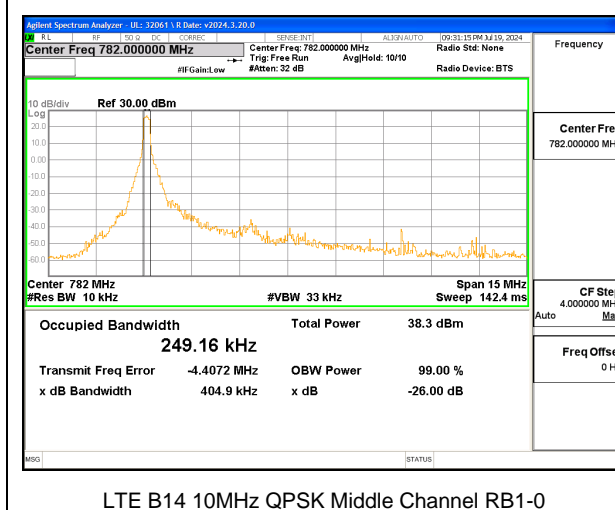

LTE B14 10MHz QPSK Middle Channel RB1-0

Intentionally Blank

5G NR n14

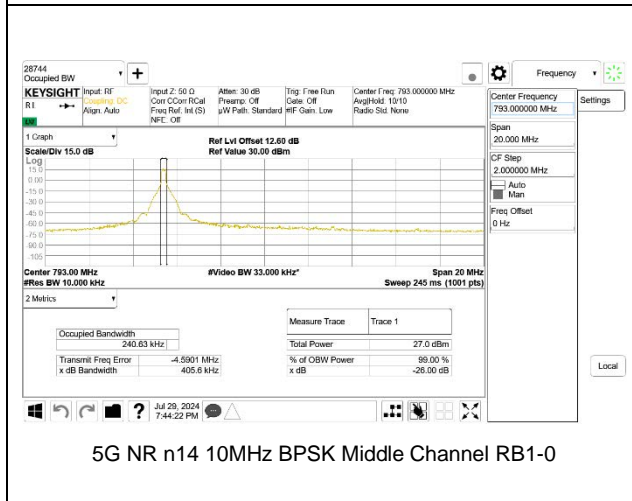
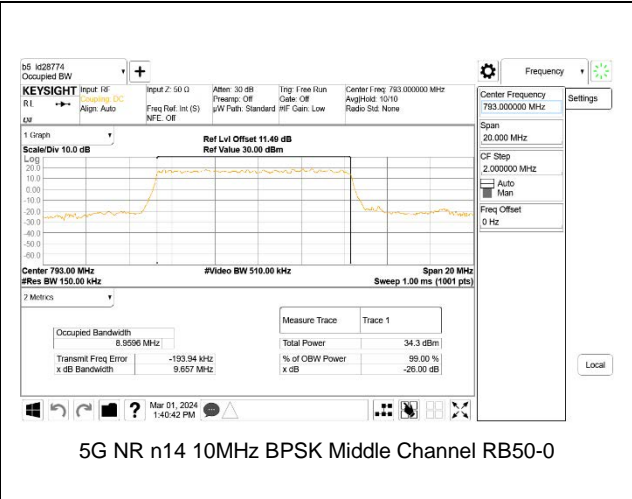
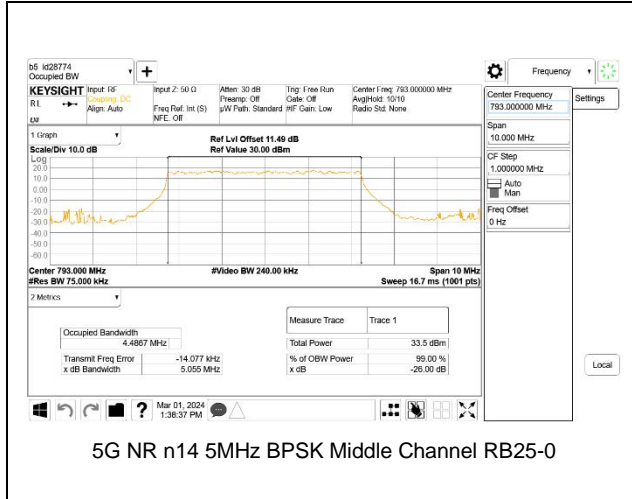

Intentionally Blank

9.1.5. LTE BAND 17

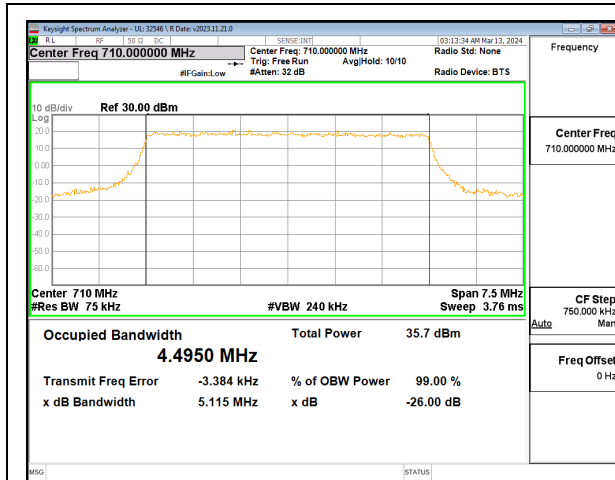

LTE B17 5MHz QPSK Middle Channel RB25-0

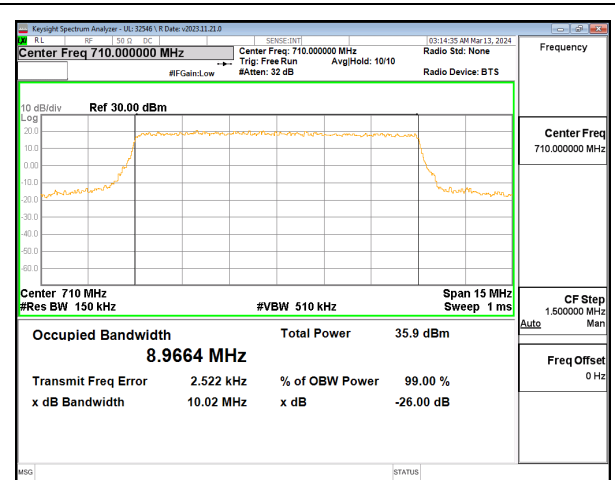

LTE B17 10MHz QPSK Middle Channel RB50-0

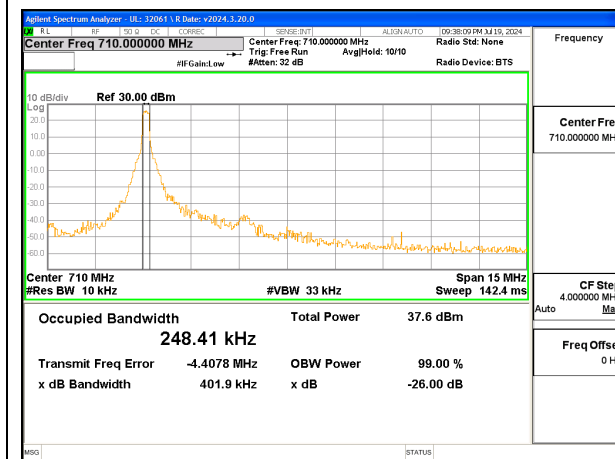

LTE B17 10MHz QPSK Middle Channel RB1-0

Intentionally Blank

9.1.6. LTE BAND 25 AND 5G NR n25

LTE BAND 25

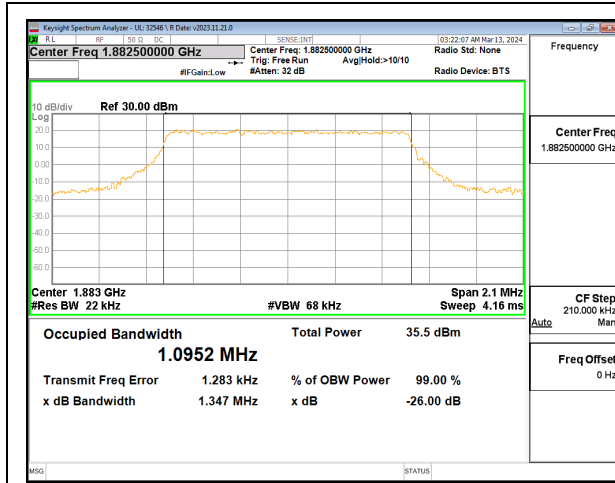

LTE B25 1.4MHz QPSK Middle Channel RB6-0

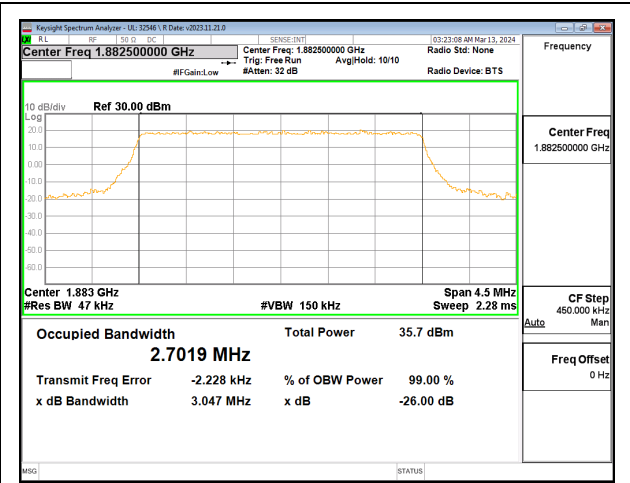

LTE B25 3MHz QPSK Middle Channel RB15-0

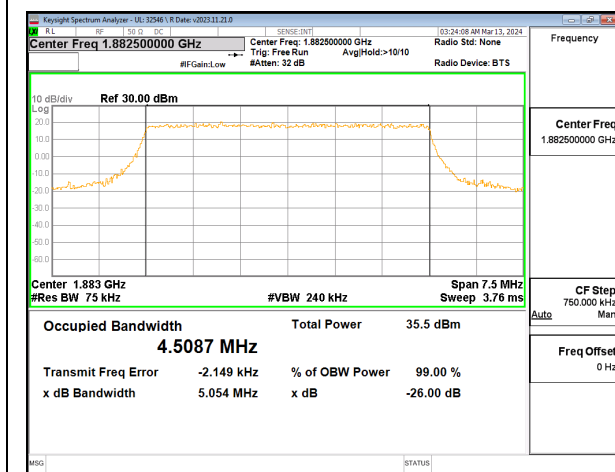

LTE B25 5MHz QPSK Middle Channel RB25-0

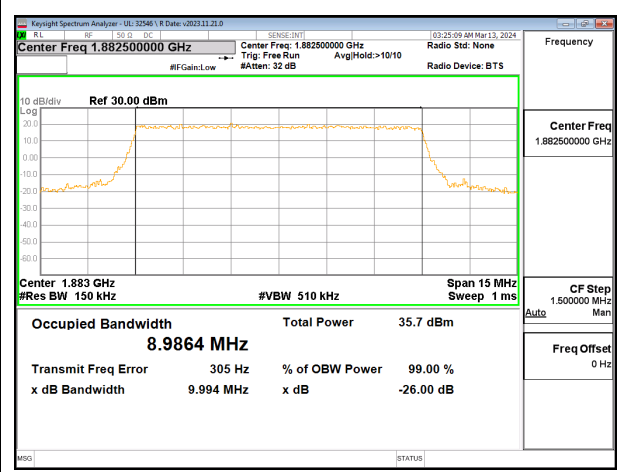

LTE B25 10MHz QPSK Middle Channel RB50-0

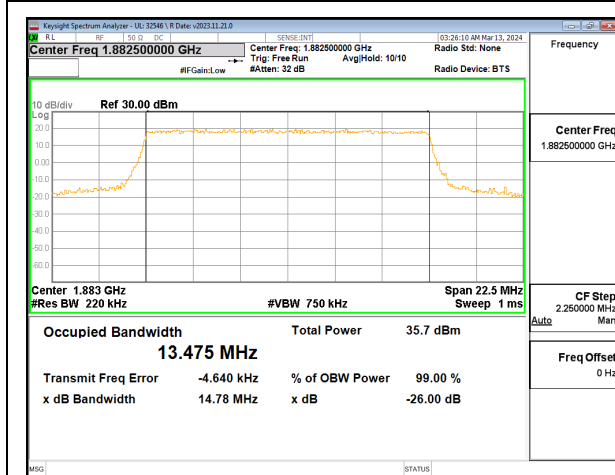

LTE B25 15MHz QPSK Middle Channel RB75-0

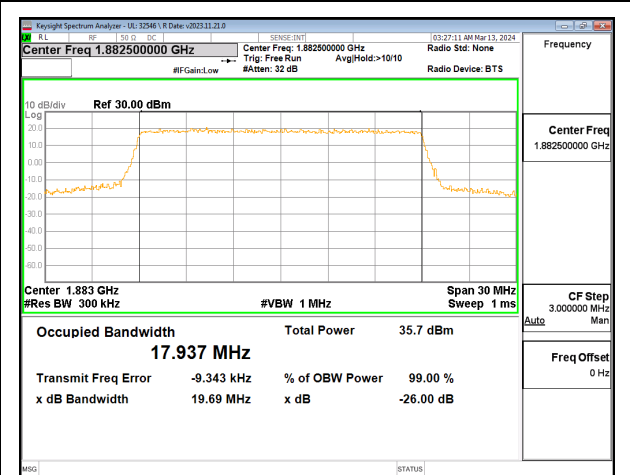

LTE B25 20MHz QPSK Middle Channel RB100-0

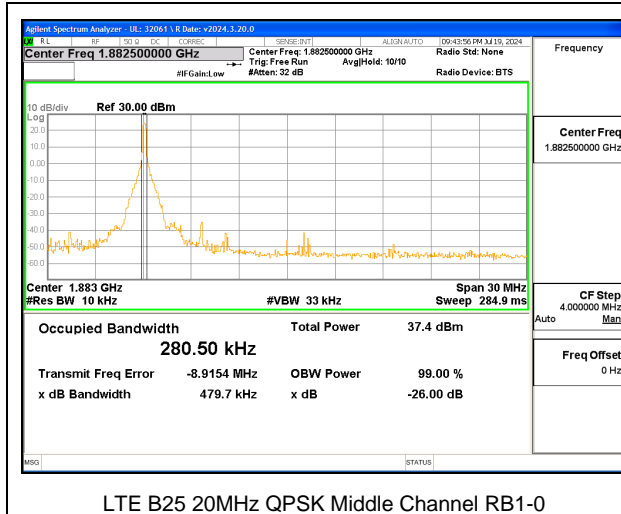

Intentionally Blank

5G NR n25

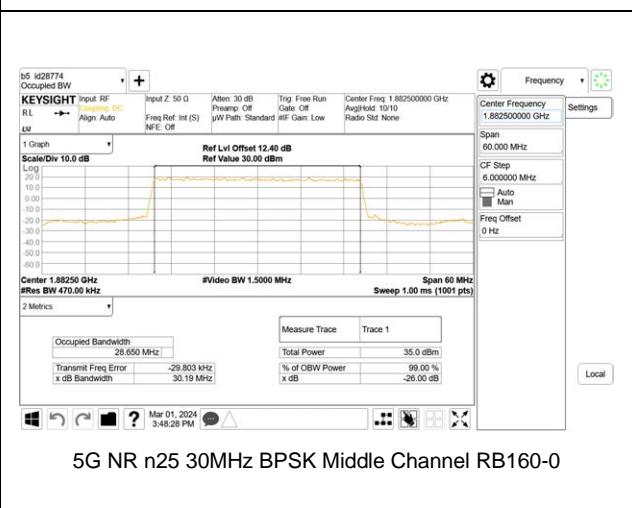
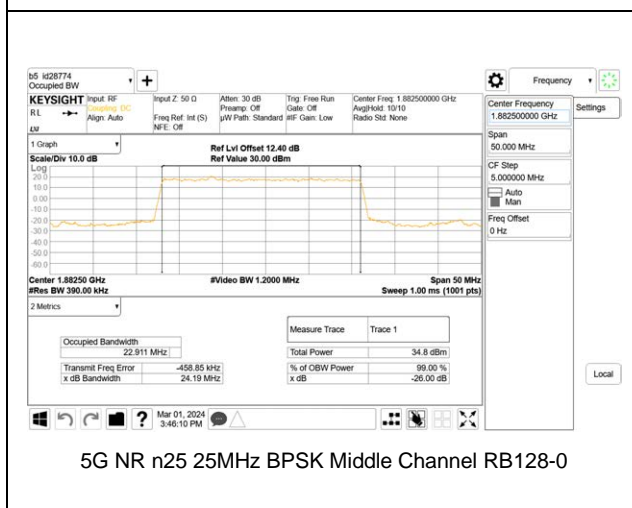
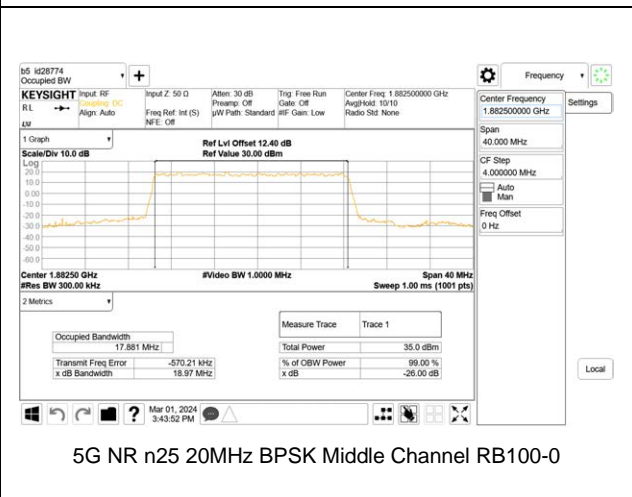
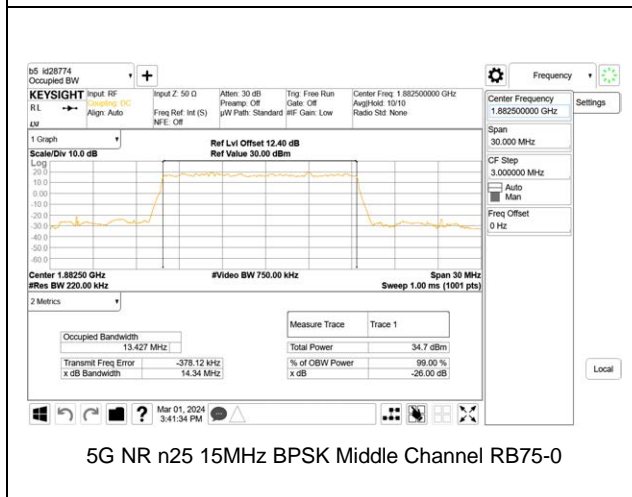
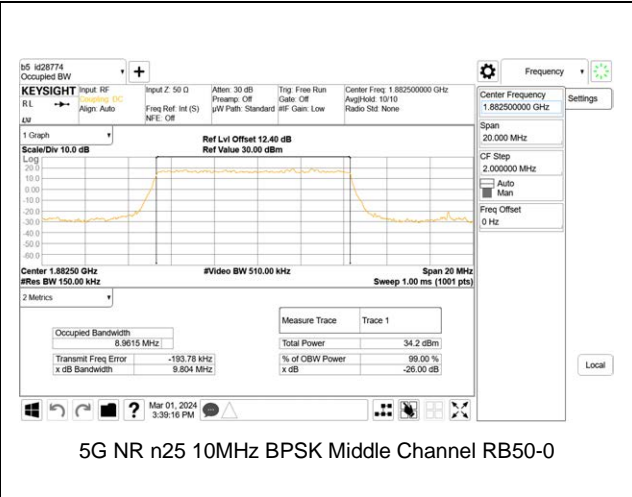
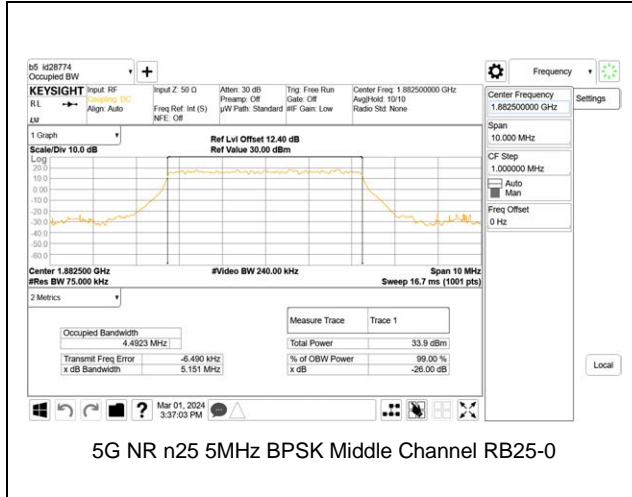

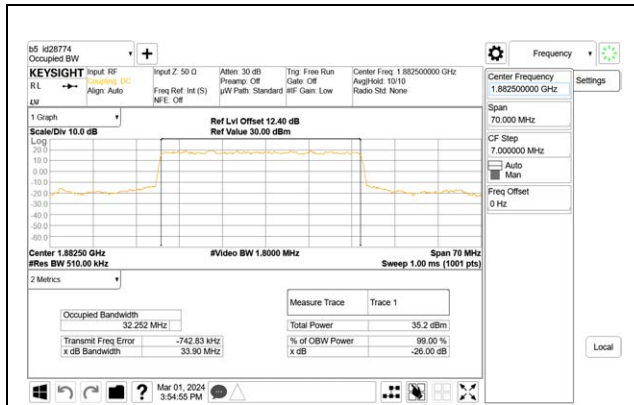

5G NR n25 35MHz BPSK Middle Channel RB180-0

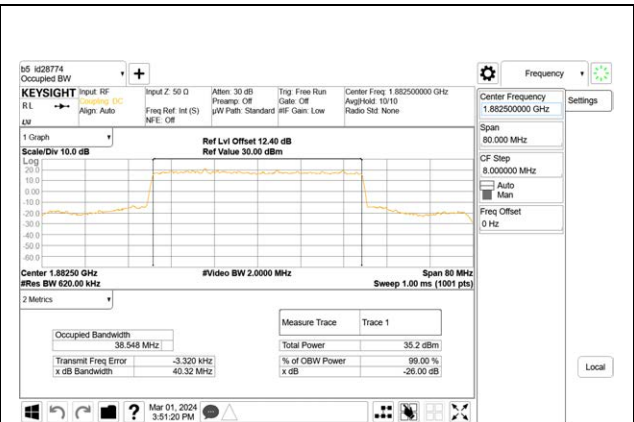

5G NR n25 40MHz BPSK Middle Channel RB216-0

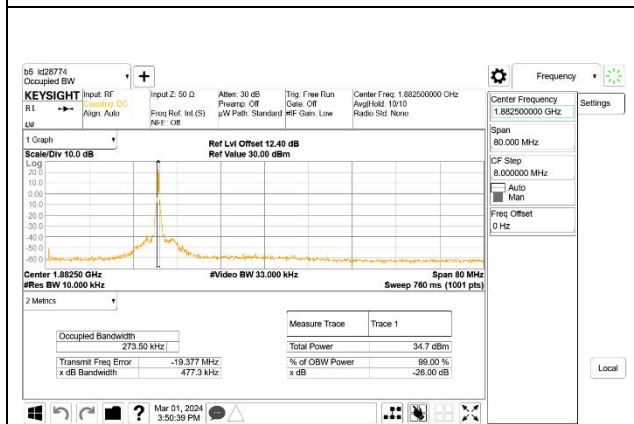

5G NR n25 40MHz BPSK Middle Channel RB1-0

Intentionally Blank

9.1.7. LTE BAND 26 AND 5G NR n26 (FCC PART 90S)

LTE BAND 26

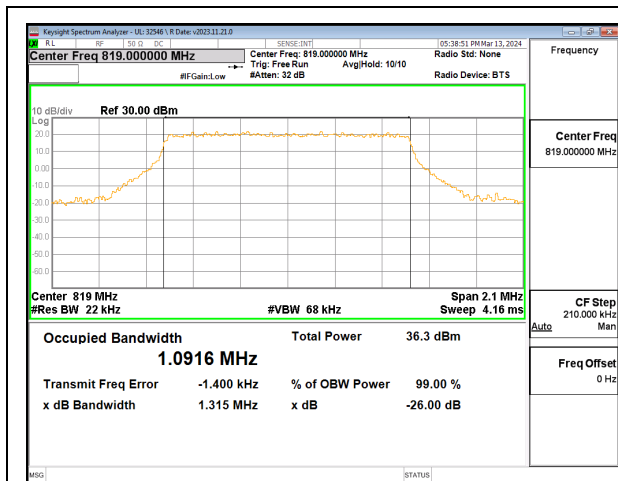

LTE B26 1.4MHz QPSK Middle Channel RB6-0

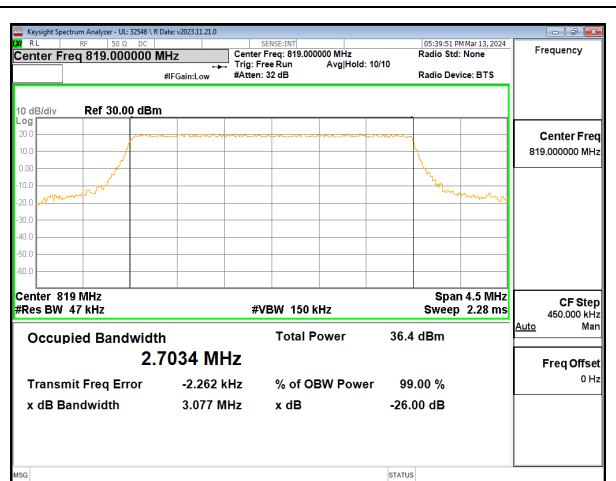

LTE B26 3MHz QPSK Middle Channel RB15-0

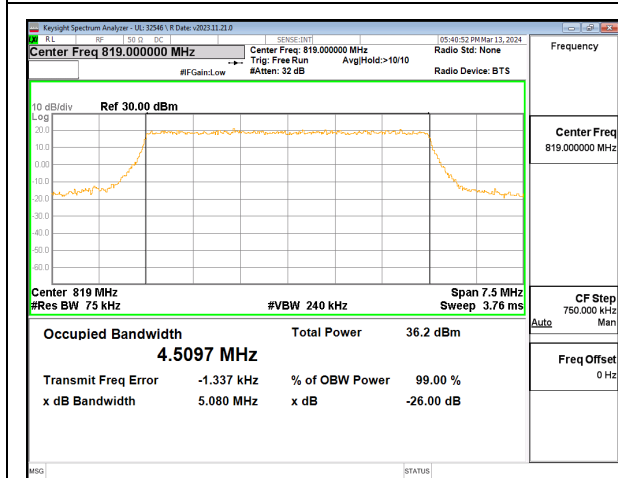

LTE B26 5MHz QPSK Middle Channel RB25-0

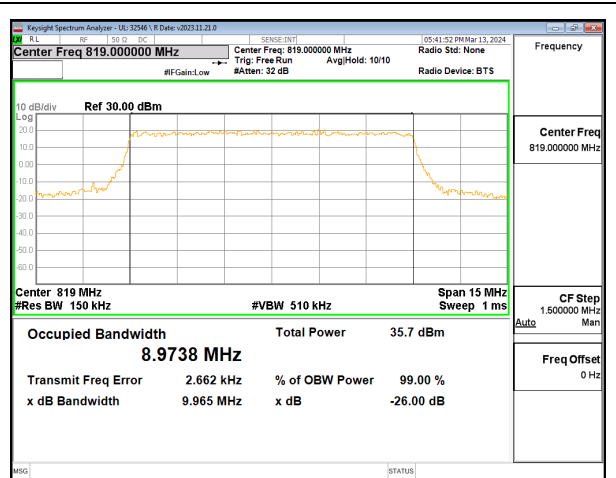

LTE B26 10MHz QPSK Middle Channel RB50-0

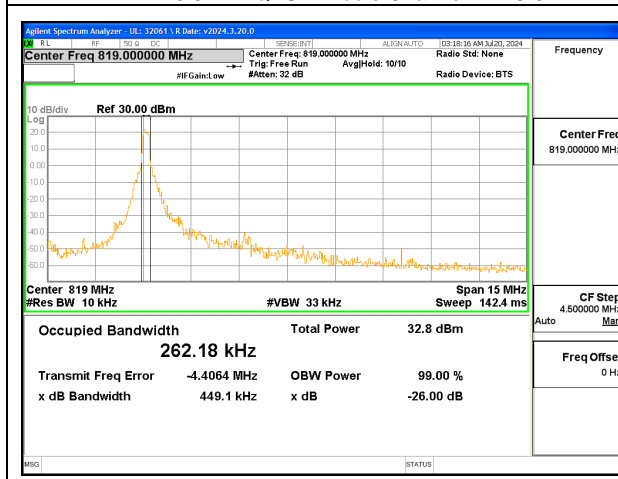

LTE B26 10MHz QPSK Middle Channel RB1-0

Intentionally Blank

5G NR n26

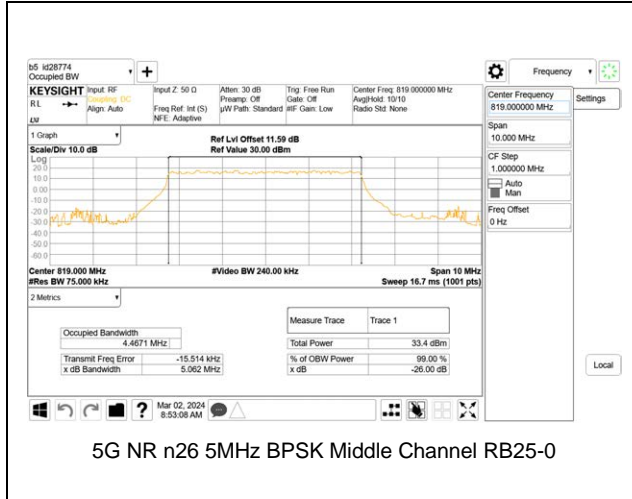

5G NR n26 5MHz BPSK Middle Channel RB25-0

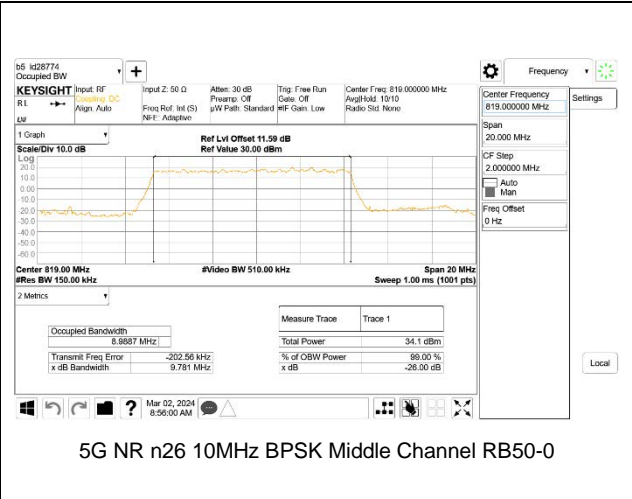

5G NR n26 10MHz BPSK Middle Channel RB50-0

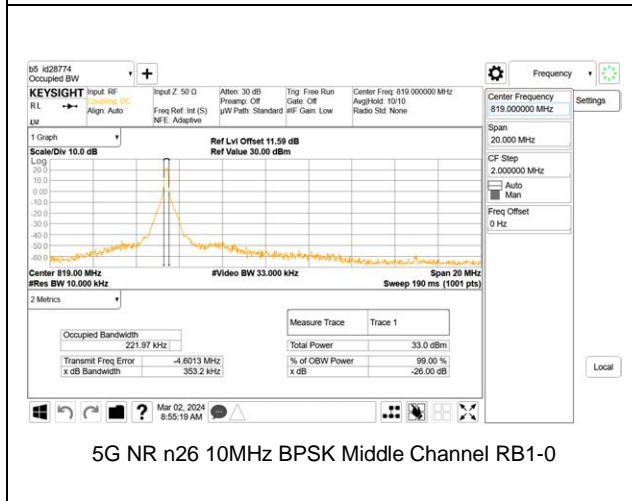

5G NR n26 10MHz BPSK Middle Channel RB1-0

Intentionally Blank

9.1.8. LTE BAND 26 AND 5G NR n26 (FCC PART 22)

LTE BAND 26

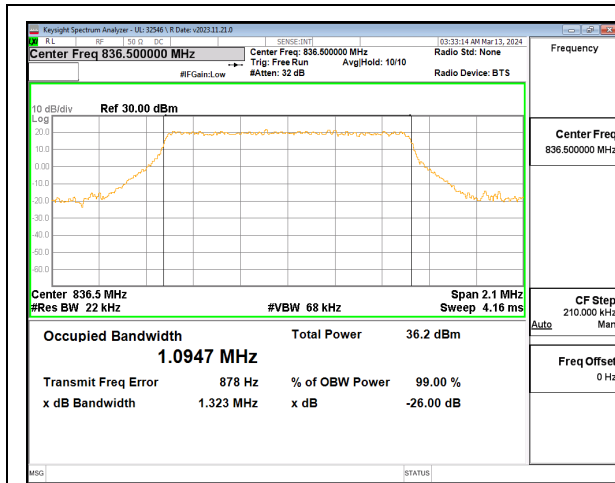

LTE B26 1.4MHz QPSK Middle Channel RB6-0

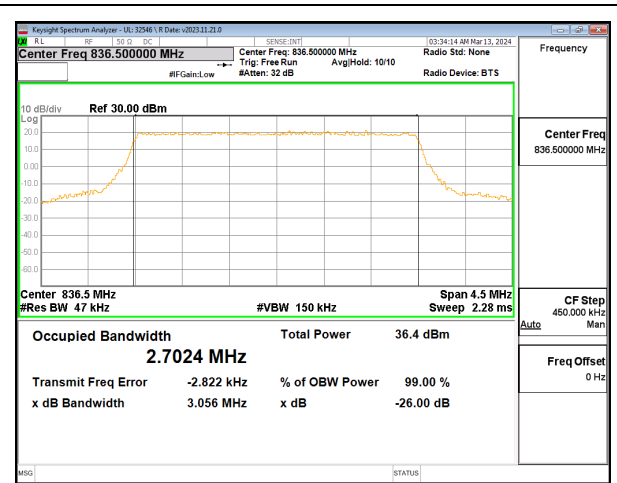

LTE B26 3MHz QPSK Middle Channel RB15-0

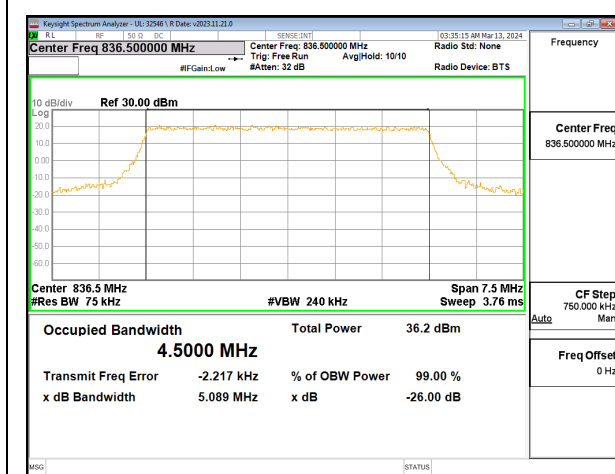

LTE B26 5MHz QPSK Middle Channel RB25-0

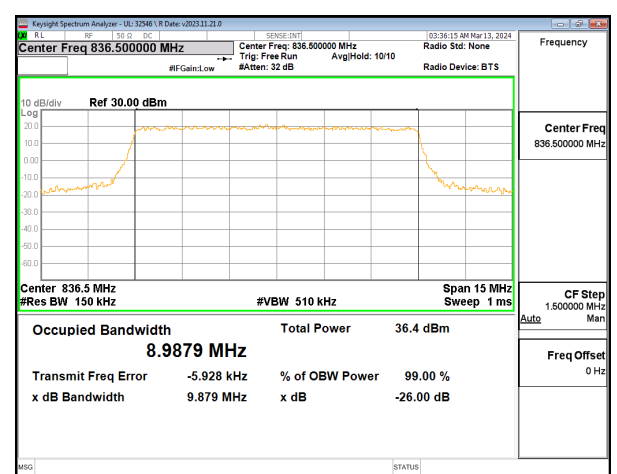

LTE B26 10MHz QPSK Middle Channel RB50-0

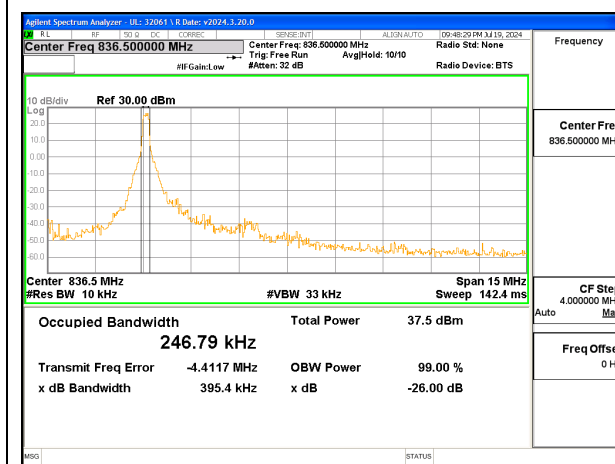

LTE B26 10MHz QPSK Middle Channel RB1-0

Intentionally Blank

5G NR n26

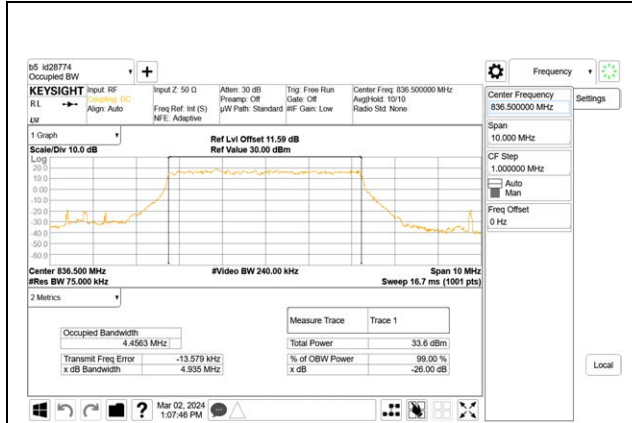

5G NR n26 5MHz BPSK Middle Channel RB25-0



5G NR n26 10MHz BPSK Middle Channel RB50-0

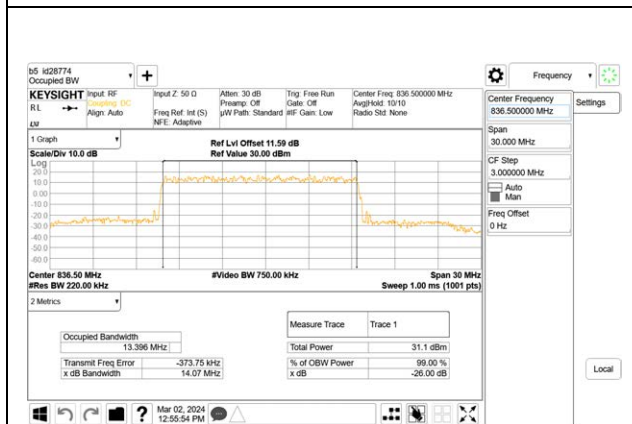

5G NR n26 15MHz BPSK Middle Channel RB75-0

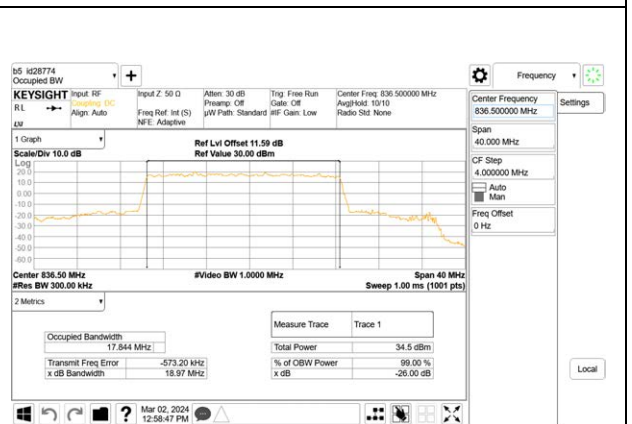

5G NR n26 20MHz BPSK Middle Channel RB100-0

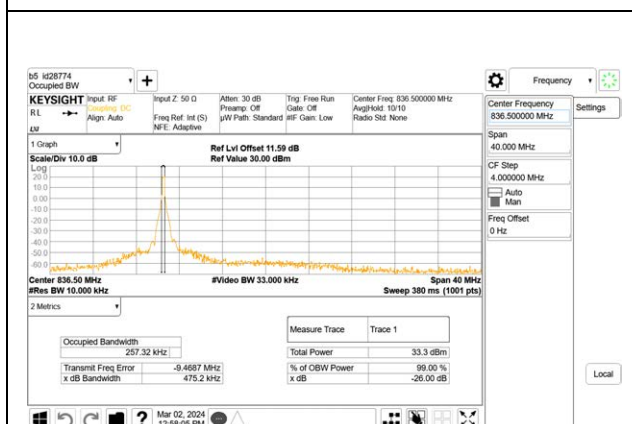

5G NR n26 20MHz Middle High Channel RB1-0

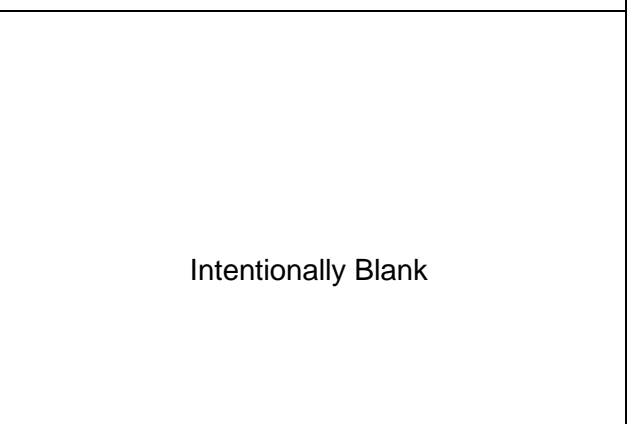

Intentionally Blank

9.1.9. LTE BAND 30 AND 5G NR n30

LTE BAND 30

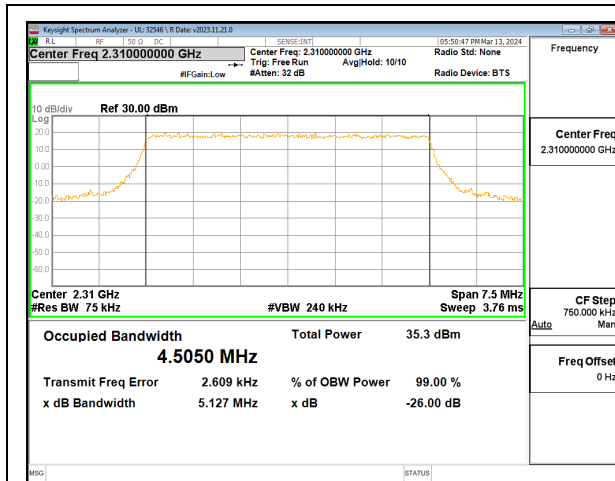

LTE B30 5MHz QPSK Middle Channel RB25-0

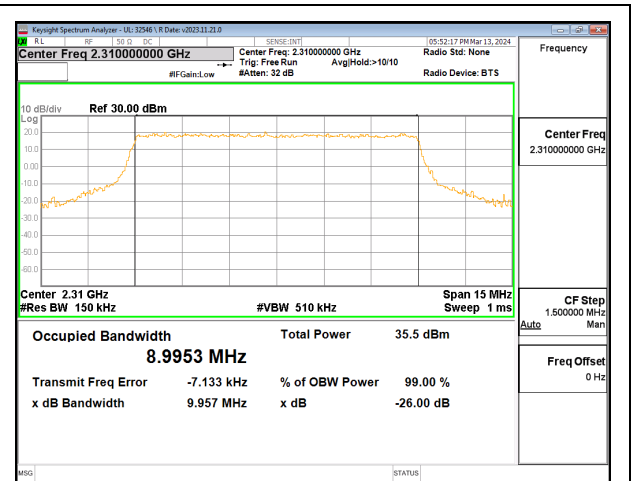

LTE B30 10MHz QPSK Middle Channel RB50-0

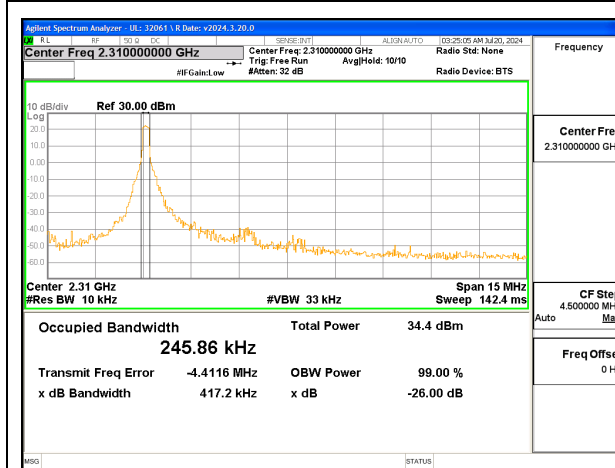

LTE B30 10MHz QPSK Middle Channel RB1-0

Intentionally Blank

5G NR n30

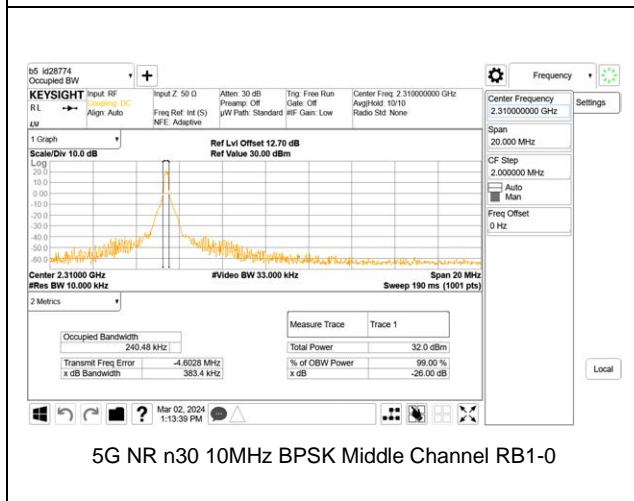
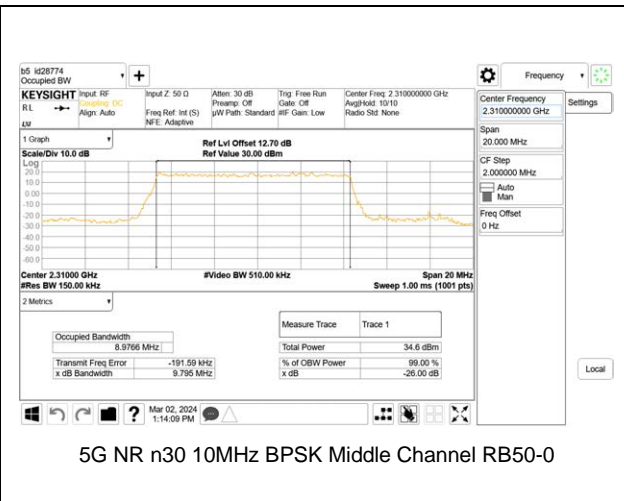
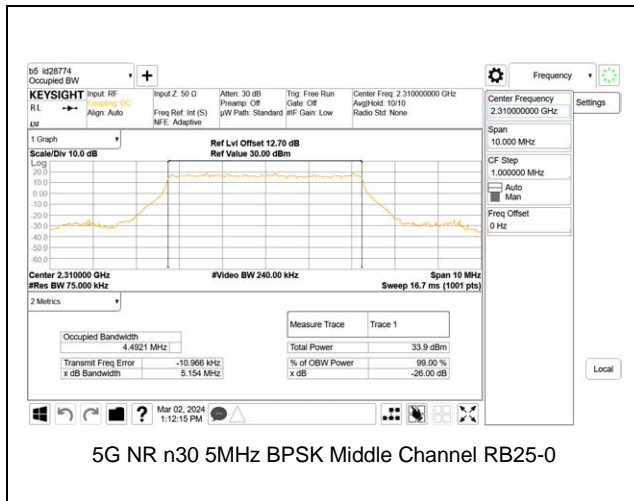

9.1.10. LTE BAND 41 AND 5G NR n41

LTE BAND 41

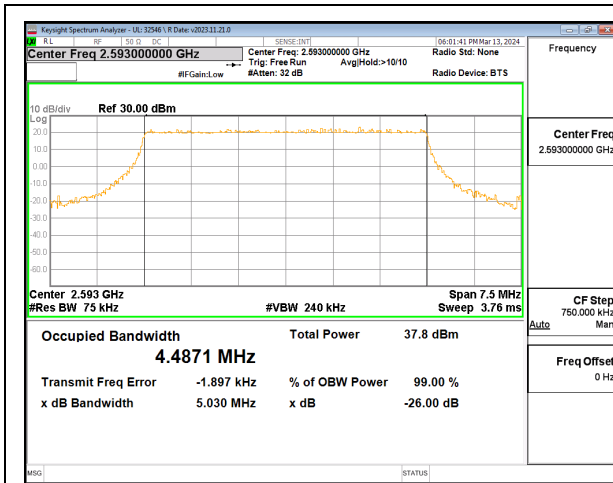

LTE B41 5MHz QPSK Middle Channel RB25-0

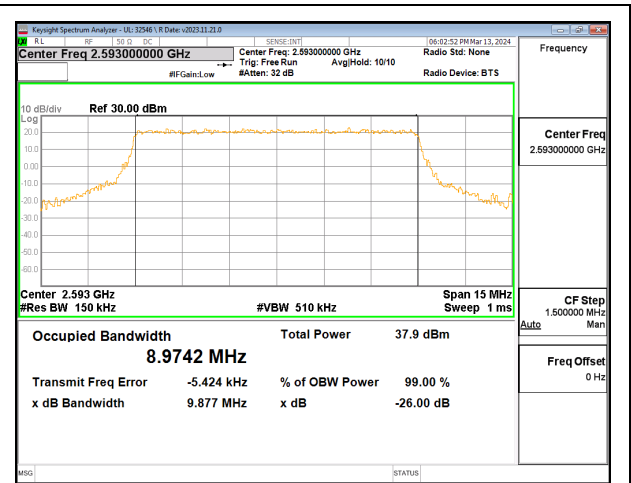

LTE B41 10MHz QPSK Middle Channel RB50-0

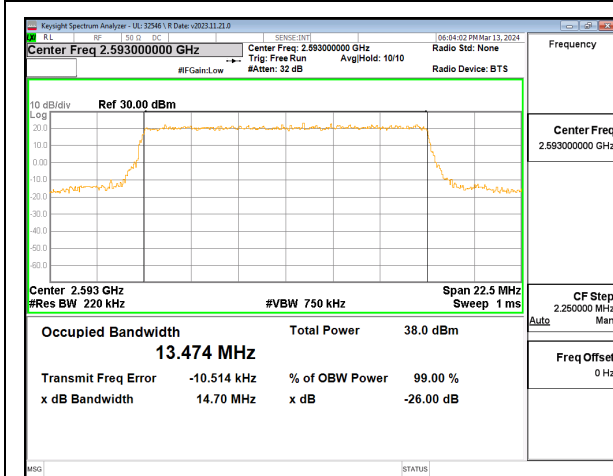

LTE B41 15MHz QPSK Middle Channel RB75-0

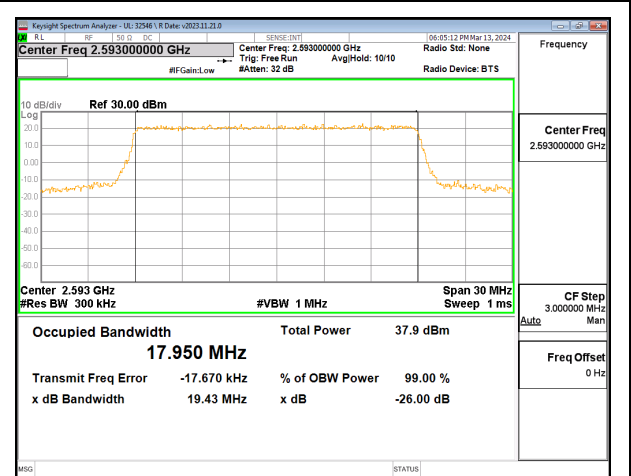

LTE B41 20MHz QPSK Middle Channel RB100-0

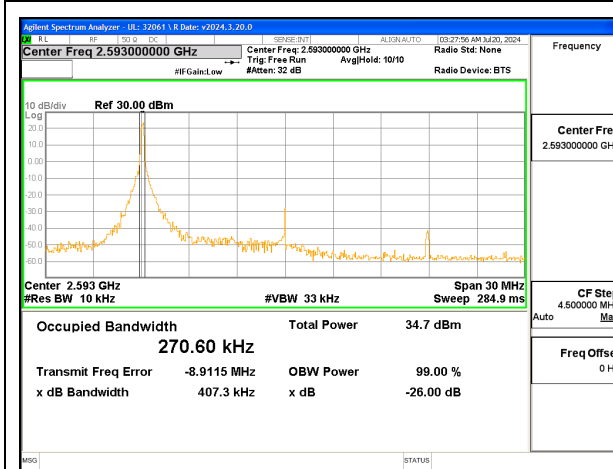

LTE B41 20MHz QPSK Middle Channel RB1-0

Intentionally Blank

5G NR n41

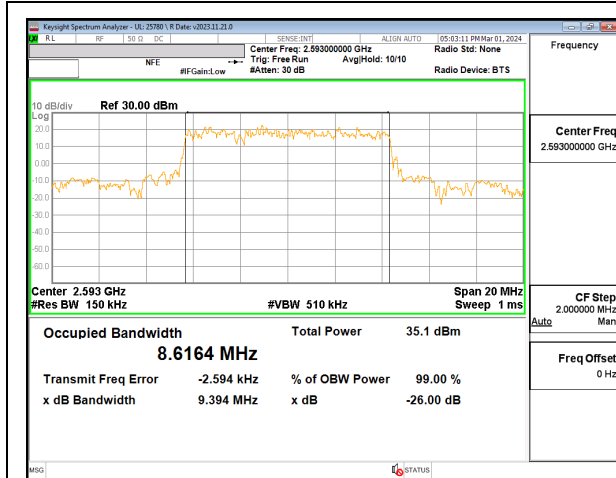

5G NR n41 10MHz BPSK Middle Channel RB24-0

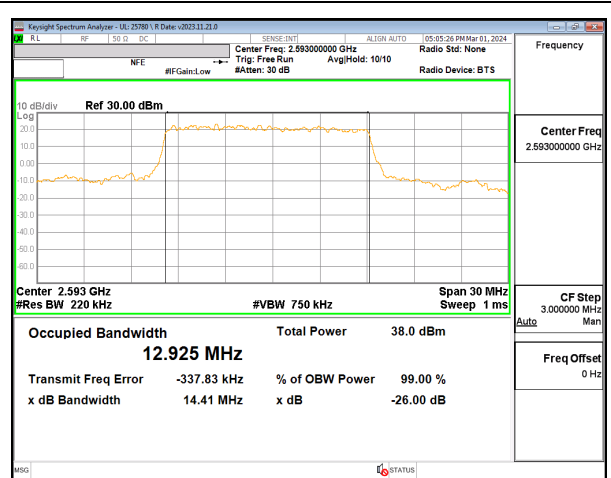

5G NR n41 15MHz BPSK Middle Channel RB36-0

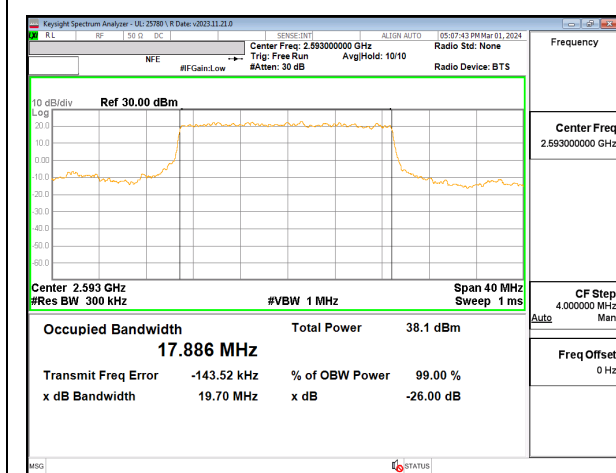

5G NR n41 20MHz BPSK Middle Channel RB50-0

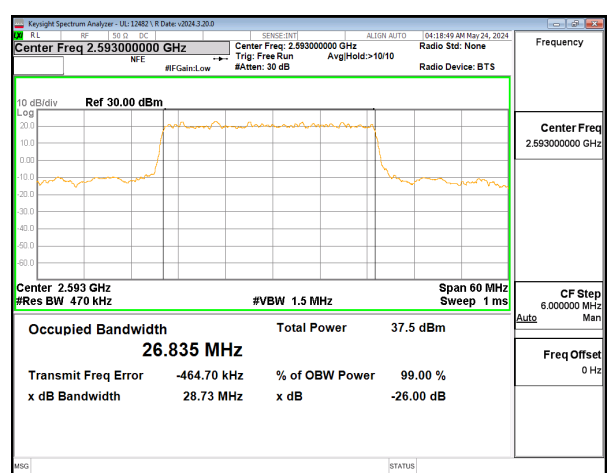

5G NR n41 30MHz BPSK Middle Channel RB75-0

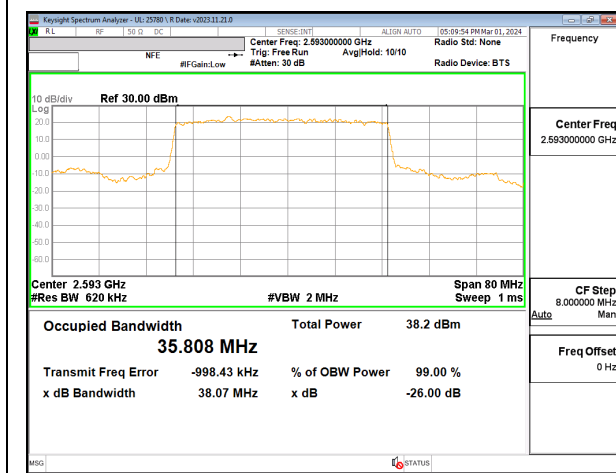

5G NR n41 40MHz BPSK Middle Channel RB100-0

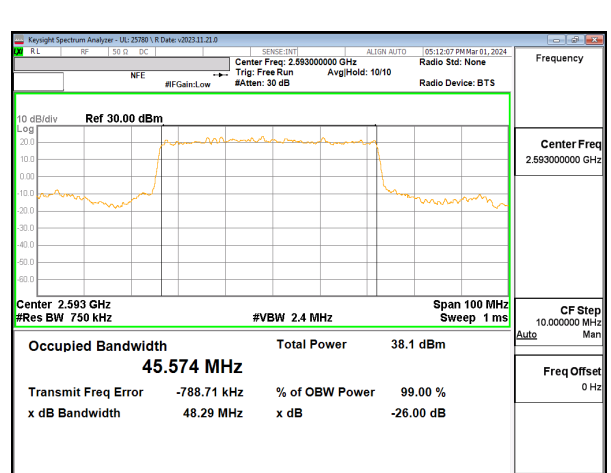

5G NR n41 50MHz BPSK Middle Channel RB128-0

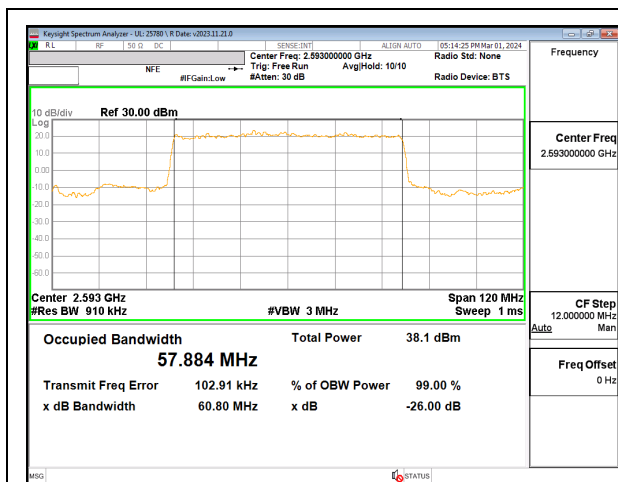

5G NR n41 60MHz BPSK Middle Channel RB162-0

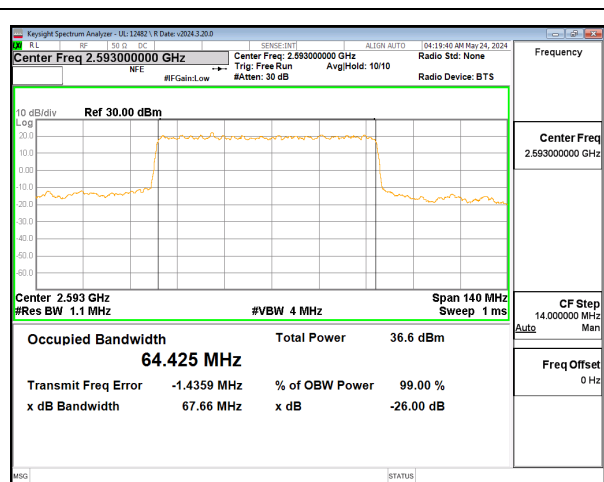

5G NR n41 70MHz BPSK Middle Channel RB180-0

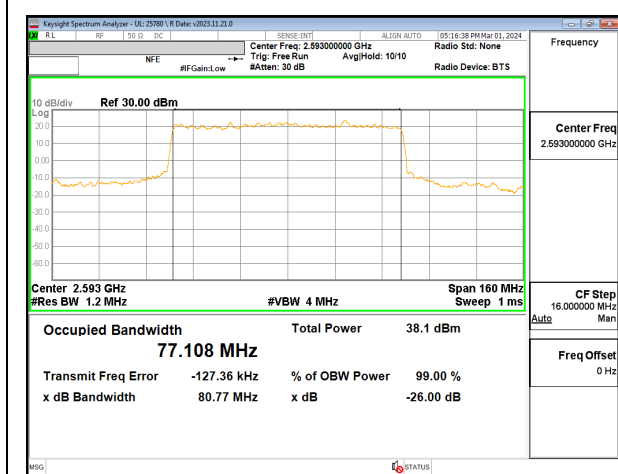

5G NR n41 80MHz BPSK Middle Channel RB216-0

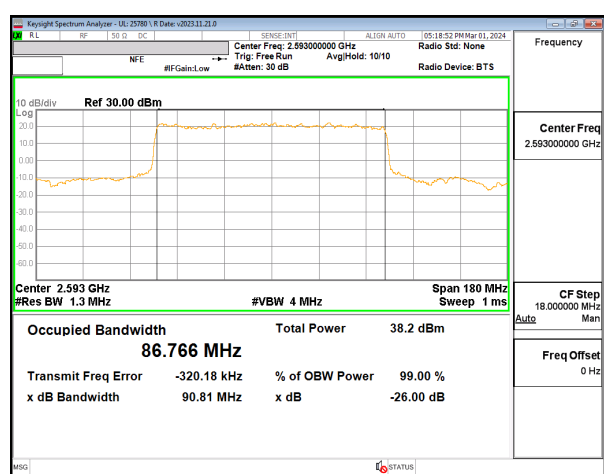

5G NR n41 90MHz BPSK Middle Channel RB243-

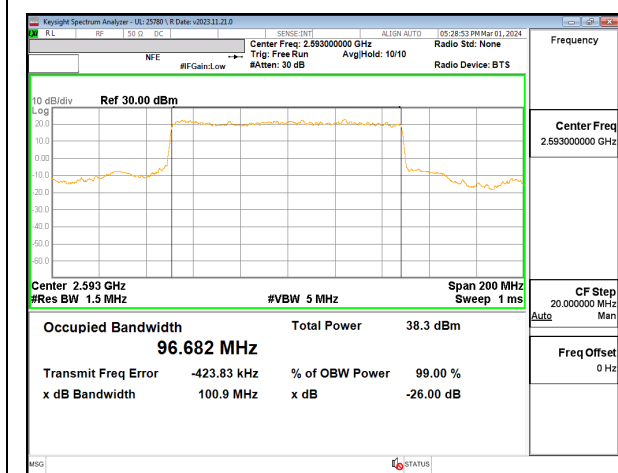

5G NR n41 100MHz BPSK Middle Channel RB270-0

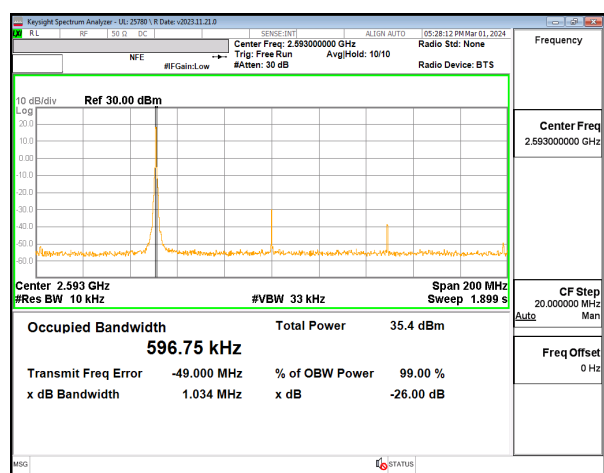

5G NR n41 100MHz BPSK Middle Channel RB1-0

9.1.11. LTE BAND 66 AND 5G NR n66

LTE BAND 66

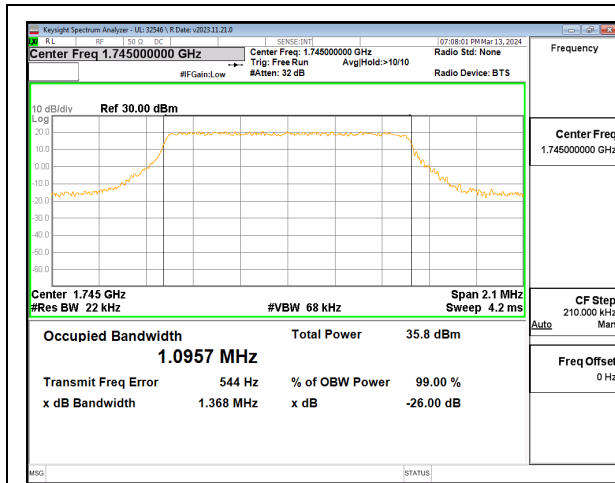

LTE B66 1.4MHz QPSK Middle Channel RB6-0

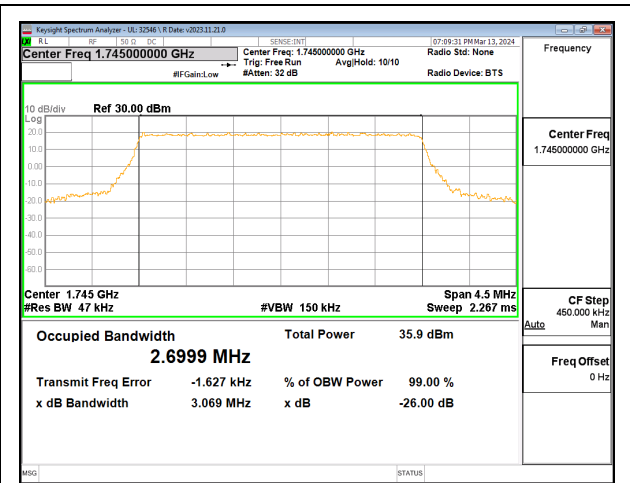

LTE B66 3MHz QPSK Middle Channel RB15-0

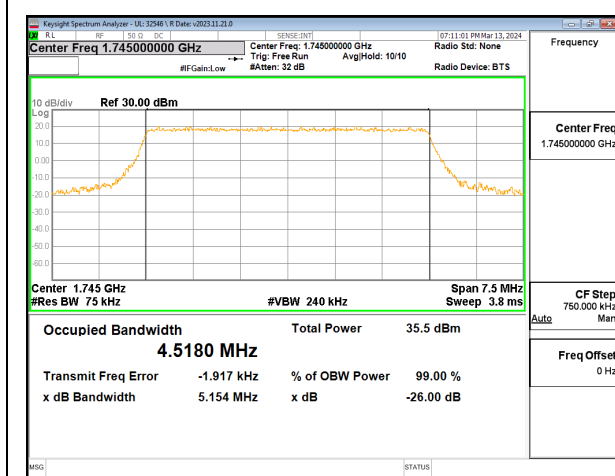

LTE B66 5MHz QPSK Middle Channel RB25-0

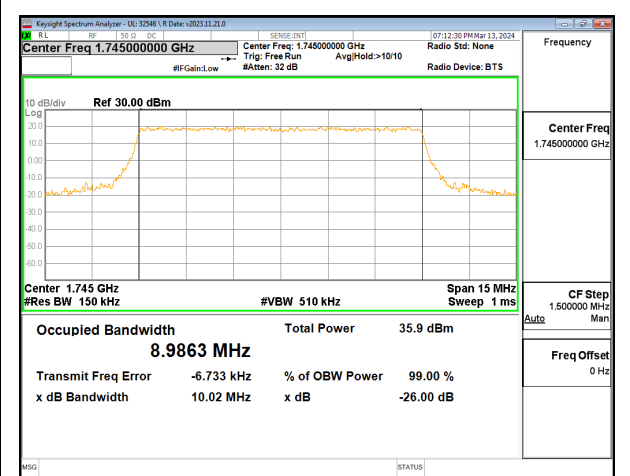

LTE B66 10MHz QPSK Middle Channel RB50-0

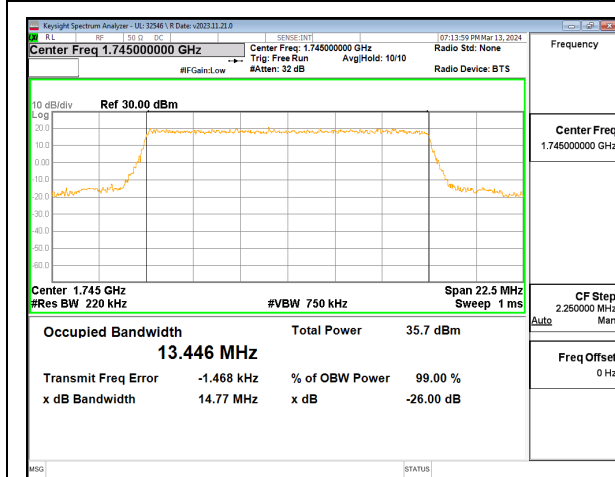

LTE B66 15MHz QPSK Middle Channel RB75-0

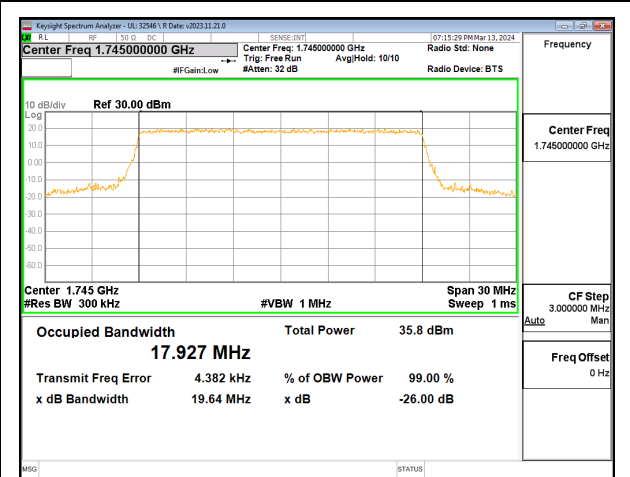

LTE B66 20MHz QPSK Middle Channel RB100-0

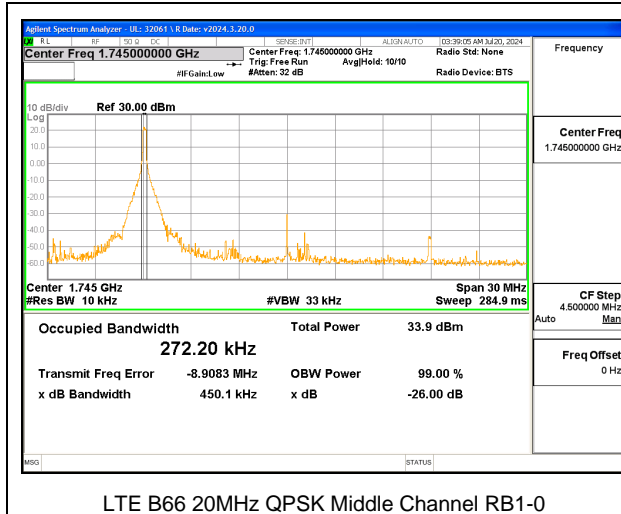

Intentionally Blank