



HAC VOLUME CONTROL TEST REPORT

**FCC 47 CFR § 20.19
ANSI C63.19-2019**

For
SMARTPHONE

**FCC ID: BCG-E8690A
Model Name: A3287**

**Report Number: 14982486-S3V2
Issue Date: 8/1/2024**

Prepared for
**APPLE INC.
1 APPLE PARK WAY
CUPERTINO, CA 95014-2084**

Prepared by
**UL VERIFICATION SERVICES INC.
47173 BENICIA STREET
FREMONT, CA 94538, U.S.A.
TEL: (510) 319-4000
FAX: (510) 661-0888**



Revision History

Rev.	Date	Revisions	Revised By
V1	7/19/2024	Initial Issue	--
V2	8/1/2024	Section 7.1: Updated note	Coltyce Sanders

Table of Contents

1. Attestation of Test Results	4
2. Test Methodology	5
3. Facilities and Accreditation	5
4. Calibration and Uncertainty	6
4.1. <i>Measuring Instrument Calibration</i>	<i>6</i>
4.2. <i>Measurement Uncertainty</i>	<i>6</i>
5. Test Considerations per ANSI/TIA-5050-2018, §4.....	7
5.1. <i>Adjustable Frequency Response</i>	<i>7</i>
5.2. <i>Acoustic Test Interface Equipment.....</i>	<i>7</i>
5.3. <i>Handset Positioning and Mounting Force</i>	<i>7</i>
5.4. <i>Test Signal and Analysis</i>	<i>7</i>
5.5. <i>Narrowband and Wideband Transmission Modes</i>	<i>7</i>
5.6. <i>Air Interface</i>	<i>7</i>
5.7. <i>Precautions.....</i>	<i>8</i>
5.8. <i>Test Arrangement.....</i>	<i>8</i>
6. Test Procedures per KDB 285076 D05 & ANSI/TIA-5050-2018, §5.....	9
6.1. <i>Receive Volume Control Performance & Receive Distortion and Noise Performance</i>	<i>9</i>
6.1.1. <i>Test Requirements.....</i>	<i>9</i>
6.1.2. <i>Receive Volume Control Performance Measurement Method</i>	<i>9</i>
6.1.3. <i>Receive Distortion and Noise Performance Measurement Method.....</i>	<i>10</i>
6.2. <i>Receive Acoustic Frequency Response Performance.....</i>	<i>11</i>
6.2.1. <i>Test Requirement.....</i>	<i>11</i>
6.2.2. <i>Receive Acoustic Frequency Response Performance Measurement Method</i>	<i>12</i>
7. Device Under Test.....	13
7.1. <i>Air Interfaces and Operating Mode</i>	<i>13</i>
8. HAC (Volume Control) Test Results	15
Appendix.....	18
<i>Appendix A: Volume Control Setup Photo.....</i>	<i>18</i>
<i>Appendix B: Volume Control Test Plots.....</i>	<i>18</i>
<i>Appendix C: HAC Waiver DA 23-914</i>	<i>18</i>

Table of Tables

Table 6-1: Stimulus and Stimulus Measurement Bands for PN-SDNR	10
Table 6-2: Narrowband Receive Frequency Response Limits	11
Table 6-3: Wideband Receive Frequency Response Limits.....	12

Table of Figures

Figure 5-1: Test Arrangement.....	8
Figure 6-1: Narrowband Receive Frequency Response Limits	12
Figure 6-2: Wideband Receive Frequency Response Limits	12

1. Attestation of Test Results

Applicant Name	APPLE, INC.	
FCC ID	BCG-E8690A	
Model Name	A3287	
Applicable Standards	FCC 47 CFR § 20.19 ANSI C63.19-2019 ANSI/TIA 5050-2018 Waiver order DA 23-914	
Conversational Gain Limits (dB)	2N	8N
	≥ 6	
Worst case Conversational Gain (dB)	13.24	21.04
Date Tested	6/24/2024 to 7/16/2024	
Test Results	Pass	

UL Verification Services Inc. tested the above equipment in accordance with the requirements set forth in the above standards. The test results show that the equipment tested can demonstrate compliance with the requirements as documented in this report.

This report contains data provided by the customer which can impact the validity of results. UL Verification Services Inc. is only responsible for the validity of results after the integration of the data provided by the customer.

The results documented in this report apply only to the tested sample, under the conditions and modes of operation as described herein. It is the manufacturer's responsibility to assure that additional production units of this model are manufactured with identical electrical and mechanical components. All samples tested were in good operating condition throughout the entire test program. Measurement Uncertainties are published for informational purposes only and were not considered unless noted otherwise.

This document may not be altered or revised in any way unless done so by UL Verification Services Inc. and all revisions are noted in the revisions section. Any alteration of this document not carried out by UL Verification Services Inc. will constitute fraud and shall nullify the document. This report must not be used by the client to claim product certification, approval, or endorsement by A2LA, NIST, or any agency of the U.S. Government, or any agency of the U.S. government.

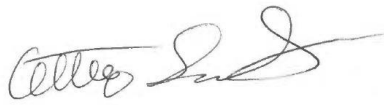
Approved & Released By:	Prepared By:
	
Devin Chang Senior Laboratory Engineer UL Verification Services Inc.	Coltyce Sanders Staff Laboratory Engineer UL Verification Services Inc.

2. Test Methodology

The tests documented in this report were performed in accordance with ANSI C63.19-2019 and ANSI/TIA-5050-2018. Methods of Measurement of Compatibility between Wireless Communications Devices and Hearing Aids and FCC published procedures:

KDB 285076 D04 Volume Control v02
 KDB 285076 D05 CG Interim Waiver DA 23-914 v01
 KDB 388624 D02 Pre-Approval Guidance List v18r05 (WAIVER)

In addition to the above, the following guidance was used:
 TCB workshop updates:

- TCB Workshop October 2023; HAC Updates (HAC Waiver Test Guidance for HAC Compliance)
- TCB Workshop April 2024; HAC Updates (Handset Configuration)

3. Facilities and Accreditation

The test sites and measurement facilities used to collect data are located at

47266 Benicia Street
Audio Chamber 1

UL Verification Services Inc. is accredited by A2LA, Certificate Number 0751.05

The Test Lab Conformity Assessment Body Identifier (CABID) (for IC only)

Location	CABID	Company Number
47173 Benicia Street, Fremont, CA, 94538 UNITED STATES	US0104	2324A
47266 Benicia Street, Fremont, CA, 94538 UNITED STATES		

4. Calibration and Uncertainty

4.1. Measuring Instrument Calibration

The measuring equipment used to perform the tests documented in this report has been calibrated in accordance with the manufacturers' recommendations and is traceable to recognized national standards.

Lab Equipment

Name of Equipment	Manufacturer	Type/Model	Serial No.	Cal. Due Date
Head and Torso Simulator	Brüel & Kjær	-4128-C-001	3244297	5/31/2025
Signal Conditioner/Amplifier	Brüel & Kjær	-1708-	100337	5/31/2025
Sound & Vibration Measurement A/S	Brüel & Kjær	-3670-A-082	3670-000087	5/31/2025
Handset Positioner	Brüel & Kjær	4606	2435148	N/A
Sound Calibrator	Brüel & Kjær	4231	3025131	5/31/2025
DAC	Yellow tech	YT4211	22000115	N/A
Radio Communication Tester	R & S	CMW 500	170269-HX	2/21/2025
Radio Communication Tester	R & S	CMW 500	170415-uw	2/28/2025
Radio Communication Tester	R & S	CMX 500	101156-bz	3/18/2025
Up/Down-Converter	R & S	CMW-Z800A	100198-XW	2/28/2025

4.2. Measurement Uncertainty

Measurement Uncertainty for Volume Control Measurement

Uncertainty Component	Tol. ($\pm\%$)	Probe Dist.	Div.	c_i	v_i	u_i ($\pm\%$)
Measurement System - Input Channels of Audio Interface						
Overall Frequency Resonse (re. 1 kHz)	0.02	R	1.732	1	∞	0.01
Measurement System - Output Channels of Audio Interface						
Measurement System - Pre-Amplifier						
Gain Tolerance 10 Hz 100 kHz	0.01	R	1.732	1	∞	0.01
Measurement System - Ear Simulator						
Typical Sensitivity	0.19	R	1.73	1	∞	0.11
Test Sample Related						
Repeatability Test (Conversational Gain)	0.47	N	1	1	40	0.47
Repeatability Test (Acoustic Frequency Response)	1.56	N	1	1	40	1.56
Repeatability Test (Distortion)	8.69	N	1	1	40	8.69
Combined Standard Uncertainty $U_c(y) =$			Expanded Uncertainty			
Conversational Gain	0.48	Conversational Gain			0.97	
Acoustic Response	1.56	Acoustic Frequency Response			3.12	
Distortion	8.69	Distortion			17.38	
Notes for table						
1. N - Nomal						
2. R - Rectangular						
3. Div. - Divisor used to obtain standard uncertainty						
4. c_i - is the Sensitivity coefficient						
5. u_i - Standard Uncertainty						

5. Test Considerations per ANSI/TIA-5050-2018, §4

5.1. Adjustable Frequency Response

If the terminal provides the ability to adjust the receive frequency response (e.g., via a "tone control" feature), the terminal is considered to be compliant with this Standard if it meets the requirements at one of the available frequency response settings.

5.2. Acoustic Test Interface Equipment

An ITU-T P.58 compliant Head and Torso Simulator (HATS) equipped with an ITU-T P.57 type 3.3 ear simulator shall be used for the acoustic transmission measurements specified in this standard. The ear simulator calibration and usage, and the positioning of the handset on the HATS shall be performed according to IEEE Std 269 unless stated otherwise in this document.

5.3. Handset Positioning and Mounting Force

The handset shall be placed in either the standard test position as specified in IEEE Std 269 or a recommended test position specified by the manufacturer that complies with the recommended test position requirements in IEEE Std 269.

Requirements in this standard include testing methods with a force of 2 Newtons (2N) and 8N applied when placing the handset receiver against the artificial ear pinna simulator for either the standard test position or recommended test position. The 2N force is used for testing requirements related to use by persons with hearing devices and the 8N force is used for testing requirements related to use by persons without hearing devices.

It is expected that for a person using a hearing device, the hearing device provides the desired amplification. Therefore, the tests using a force of 2N against the artificial ear pinna simulator ensure that when the telephone handset is used with a hearing device operating in the acoustic (microphone) mode, the receiver acoustics will provide the expected acoustic signals.

5.4. Test Signal and Analysis

The test signal specified for use in this document is the uncompressed real male speech as published with IEEE Std 269.

The test signal Active Speech Level (ASL) for wireless (mobile) device testing shall be -20 dBm0. The analysis shall be done in 1/12 octave bands averaged over one complete sequence of the four short sentences in the test signal unless otherwise specified.

The acoustic listener reference point shall be the Free Field (FF) or the Diffuse Field (DF) as determined in the method of measurement.

5.5. Narrowband and Wideband Transmission Modes

Under the waiver, only CMRS narrowband and CMRS wideband voice codecs are required to comply with the volume control requirements of the TIA 5050-2018 Volume Control Standard. For example, AMR and EVS codecs that operate over licensed-frequency bands and Wi-Fi Calling

5.6. Air Interface

Wireless handsets typically provide multiple air interface modes such as GSM, CDMA, WCDMA, LTE, etc. When connecting a call between the audio test system and the DUT through the Call Box, any available air interface that supports the codecs described above may be used for testing.

5.7. Precautions

Coding, decoding, packetization, and other signal processing may introduce significant delays that must be accounted for by the measurement system. Refer to IEEE Std 269 for additional precautions regarding test signal usage.

5.8. Test Arrangement

The general test arrangement is shown in Figure 5-1. The Call Box passes the voice channel stream to the DUT without modification. There is no gain or loss in the voice channel stream due to the Call Box interface. The RETP (receive electrical test point) is the point in the device test arrangement where signals are applied to the DUT in the receive direction.¹

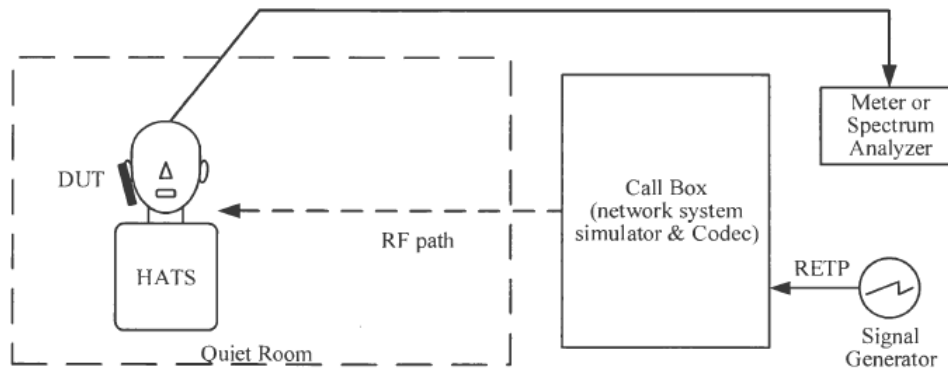

Figure 5-1: Test Arrangement

¹ Additional information related to the air interface for the various RF technologies is specified in several 3GPP documents. A list of these can be found in 3GPP TS 26.132 V14.0.0 §4. Additional information related to the test setup can be found in 3GPP TS 26.132, V14.0.0 §5.1.

6. Test Procedures per KDB 285076 D05 & ANSI/TIA-5050-2018, §5

6.1. Receive Volume Control Performance & Receive Distortion and Noise Performance

6.1.1. Test Requirements

KDB 285076 D04

The procedures for the receive volume control performance can be found in section 5.1 of TIA-5050. An ITU-T P.58 compliant Head and Torso Simulator (HATS) is required for all testing. Irrespective of codec or air interface tested, the test signal must be used in accordance with IEEE standard 269 based on the uncompressed real male speech with an active speech level (ASL) of -20 dBm0.

Special attention should be given to Narrowband and Wideband transmissions ensuring that appropriate limits are chosen based on codec performance. For codecs with performance that exceeds wideband codecs (i.e. exceeding 50 to 7,000 Hz), the wideband limits are applicable. For example, for super wideband or full band codecs, as defined by 3GPP TS26, measure the ASL frequency response for the sound pressure level from 100 to 7,720 Hz.

The device shall meet the frequency response requirements at both 2N and 8N mounting force as specified in section 5.3 of TIA-5050. Measurements shall be taken at the DRP and transformed to either the Free Field (FF) or Diffuse Field (DF). The 1/12 octave band frequency listed in TIA-5050 Tables B.1 and B.3 shall be used for all frequency response measurements.

KDB 285076 D05

This section addresses the technical testing requirements for the conversational gain, distortion, and frequency response tests that amends KDB 285076 D04 Volume Control under the conditions of the limited-term waiver DA 23-914.

- a Under the waiver, only CMRS narrowband and CMRS wideband voice codecs are required to comply with the volume control requirements of the TIA 5050-2018 Volume Control Standard as amended as follows:
 1. For the 2N mounting force test, one narrowband and one wideband voice codec embedded with the handset must pass with at least one volume control setting with a conversational gain of ≥ 6 dB for all voice services, bands of operation and air interfaces over which it operates using one codec bit rate of the applicant's choosing.
 - i. With a mounting force of 2N, the ratio of the stimulus signal power to the 100 Hz to 8000 Hz total A-weighted distortion and noise power shall be ≥ 20 dB when tested over the range of 1/3 octave band center frequencies:
 2. For the 8N mounting force test, one narrowband and one wideband voice codec embedded with the handset must pass with at least one volume control setting with a conversational gain of ≥ 6 dB for all voice services, bands of operation and air interfaces over which they operate but is not required to meet or exceed the full 18 dB of conversational gain specified in § 5.1.1 of the TIA 5050 Volume Control Standard using one codec bit rate of the applicant's choosing.
 - i. With a mounting force of 8N, the ratio of the stimulus signal power to the 100 Hz to 8000 Hz total A-weighted distortion and noise power shall be ≥ 20 dB when tested over the range of 1/3 octave band center frequencies:
- b For all other narrowband and wideband codecs not evaluated in 2.a. above, TIA 5050-2018 Receive Distortion and Noise Performance and Receive Acoustic Frequency Response Performance evaluations are not required; however, these codecs shall be assessed for conversational gain and documented in the test report at the 2N and 8N levels with a gain of ≥ 6 dB for all voice services, bands of operation and air interfaces over which they operate. The handset volume setting used to comply with 2.a. shall be used for these other CMRS codec evaluations.
- c Any other codec for voice services embedded in the handset, not identified in 2.a. and 2.b. above, is not required to comply or demonstrate in the test reports for conversational gain (e.g., Google Meet, non-3GPP VoIP codecs).

6.1.2. Receive Volume Control Performance Measurement Method

1. Configure the DUT with a mounting force of 8N and test equipment as shown in Figure 5-1 in an active call state with the applicable codec for the transmission mode under test.
2. Set the DUT volume control to the maximum setting.

3. If the DUT has an adjustable tone control feature, a tone control setting that meets the frequency response requirements in ANSI/TIA-5050-2018 §5.3.1 shall be used.
4. Apply the real speech test signal at a level of -20 dBm0 at the RETP and measure the acoustic output at the Drum Reference Point (DRP) over one complete sequence of the test signal.
5. Translate the measurement made at the DRP to the Free Field (FF) using the translation data in ANSI/TIA-5050-2018 Annex B.
6. Over the applicable frequency band, determine the ASL in dBSPL for the resulting sound pressure level in accordance with Method B of ITU-T Recommendation P.56:
 - a. Narrowband 100 Hz through 4000 Hz.
 - b. Wideband 100 Hz through 7720 Hz.
7. Calculate the Conversational Gain by subtracting 70 dB from the measured dBSPL.

$$\text{Conversation Gain} = (\text{Measured dBSPL} - 70 \text{ dBSPL}) \text{ dB}$$

8. Measure the output distortion per ANSI/TIA-5050-2018 §5.2. If a distortion failure occurs at the maximum volume control setting, reduce the volume control setting and repeat the measurement to determine if a setting can be found for which the conversational gain requirement is met without a distortion failure.
9. Repeat steps 2-8 with a mounting force of 2N.

6.1.3. Receive Distortion and Noise Performance Measurement Method

1. Configure the DUT with a mounting force of 8N and test equipment as shown in Figure 5-1 in an active call state with the applicable codec for the transmission mode under test with the volume control at the setting determined in ANSI/TIA-5050-2018 §5.1.1.
2. Receive distortion and noise is measured using the PN-SDNR procedure as described in ANSI/TIA-5050-2018 Annex A.
3. To ensure DUT activation, apply the real speech test signal at a level of -20 dBm0 followed immediately by the initial 1/3 octave center frequency PN test signal in Table 6-1 based on the narrowband or wideband operating mode. Measure the acoustic output at the DRP over the complete sequence of the PN test signal.
4. Translate the measurement made at the DRP to the FF using the translation data in ANSI/TIA-5050-2018 Annex B.
5. Calculate the acoustic output unweighted total signal power of the stimulus measurement band as described in ANSI/TIA-5050-2018 A.2.
6. Calculate the notched A-weighting distortion and noise components as described in ANSI/TIA-5050-2018 A.3.
7. Calculate the ratio of the signal power to the total A-weighted distortion and noise power using the following equation:

$$PN - SDNR(dB) = 20 * \log\left(\frac{\text{measured stimulus amplitude}}{\text{measured distortion amplitude}}\right)$$

8. Repeat for each of the remaining 1/3 octave center frequencies in Table 6-1 based on the narrowband or wideband operating mode.
9. Repeat steps 2-8 with a mounting force of 2N.

Table 6-1: Stimulus and Stimulus Measurement Bands for PN-SDNR

Stimulus Measurement Lower Band Edge	Stimulus Lower Band Edge	Nominal Center Frequency	Stimulus Upper Band Edge	Stimulus Measurement Upper Band Edge	Handset Operating Mode
190	225	250	280	315	Wideband only
245	280	315	355	390	
320	355	400	445	480	Narrowband & Wideband
410	445	500	560	595	
525	560	630	710	745	
675	710	800	890	925	
855	890	1000	1120	1155	
1085	1120	1250	1415	1450	
1375	1410	1600	1780	1815	
1745	1780	2000	2240	2275	
2205	2240	2500	2820	2855	
2785	2820	3150	3550	3585	
3515	3550	4000	4465	4500	Wideband only
4430	4465	5000	5625	5660	

6.2. Receive Acoustic Frequency Response Performance

6.2.1. Test Requirement

The receive acoustic frequency response is required to be met when tested with a handset mounting force of 2N and 8N. For a hearing device, a 2N force is used to simulate usage of the handset by a person with a hearing device in the microphone (acoustic) mode.

The receive frequency response is the ratio of the output sound pressure at the listener reference point (LRP) (FF or DF) to the voltage input to the reference codec, or digital bit stream equivalent, as shown in the equation below for each frequency or frequency band (f_i):

$$S_{JE} = 20 * \log_{10}(P_E/V_R) \text{ dB re } 1 \text{ Pa/V}$$

Where:

S_{JE}	=	Receive Sensitivity, Junction to Ear, at f_i
P_E	=	LRP sound pressure measured by ear simulator at DRP and translated to the FF or DF (see ANSI/TIA-5050-2018 Annex B), at f_i^2
V_R	=	RMS input voltage to the reference codec, or digital bit stream equivalent, at f_i

For the volume control settings determined in ANSI/TIA-5050-2018 §5.1.1 with a mounting force of 8N and 2N, the receive frequency response shall be measured at the DRP in 1/12 octave bands. After translation to the FF or DF, it shall fall between the applicable upper and lower limits.

The exact limit values at any 1/12 octave band center frequency falling between two consecutive points specified in the table may be calculated using the formula given in the equation below:

$$X_f = X_1 + (X_2 - X_1) * \left(\frac{\log_{10} f - \log_{10} f_1}{\log_{10} f_2 - \log_{10} f_1} \right)$$

Where:

X_f	=	limit value at frequency f
X_1	=	limit value at frequency f_1 as given in Table 6-2
X_2	=	limit value at frequency f_2 as given in Table 6-2

The results for each 1/12 octave band measurement are to be evaluated against the upper and lower limit values only at the center frequency point for that band (i.e., not the entire width of the band). For graphical purposes, the individual 1/12 octave band measurement results are plotted as points on a linear dB scale (y-axis) versus the band's center frequency on a logarithmic frequency scale (x-axis). The frequency response limits are floating or "best fit" (i.e., the maximum and minimum deviations from the upper and lower limits should be equidistant from those limits).

The following narrowband and wideband frequency response limits are referenced from 3GPP TS26.131.³

1. Narrowband: The 1/12 octave band frequency response after translation to the FF or DF shall fall between the upper and lower limits given in Table 6-2 and shown in Figure 6-1.

Table 6-2: Narrowband Receive Frequency Response Limits

Lower Limit Frequency (Hz)	Lower Limit (dB)	Upper Limit Frequency (Hz)	Upper Limit (dB)
300	-6	100	+6
3400	-6	4000	+6

² 3GPP frequency response requirements in TS 26.131 as measured in TS 26.132 only use the DF. This standard allows either the FF or DF to meet the frequency response requirements but requires FF for both the volume control (ANSI/TIA-5050 §5.1) and distortion and noise (ANSI/TIA-5050-2018 §5.2) requirements.

³ 3GPP TS 26.132 states the frequency response measurements are referred to the DF.

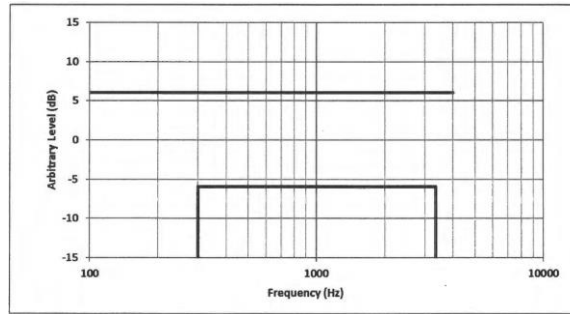

Figure 6-1: Narrowband Receive Frequency Response Limits

- Wideband: The 1112 octave band frequency response after translation to the FF or DF shall fall between the upper and lower limits given in Table 6-3 and shown in Figure 6-2.

Table 6-3: Wideband Receive Frequency Response Limits

Lower Limit Frequency (Hz)	Lower Limit (dB)	Upper Limit Frequency (Hz)	Upper Limit (dB)
200	-10	100	+6
300	-6	1000	+6
5000	-6	2000	+8
6300	-12	8000	+8

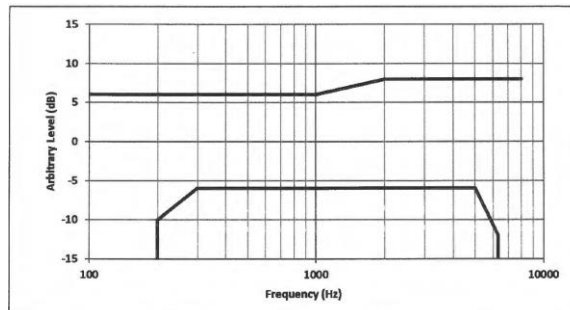

Figure 6-2: Wideband Receive Frequency Response Limits

6.2.2. Receive Acoustic Frequency Response Performance Measurement Method

- Configure the DUT with a mounting force of 8N and test equipment as shown in Figure 5-1 in an active call state with the applicable codec for the transmission mode under test with the volume control at the setting determined in ANSI/TIA-5050-2018 §5.1.1.
- If the DUT has an adjustable tone control feature the initial measurement is to be performed with the default tone control setting.
- Apply the real speech test signal with a level of -20 dBm0 at the RETP.
- Capture the frequency spectrum at the DRP of the HATS using real-time analysis with 1/12 octave bands over the frequency range from 100 Hz to 4000 Hz for narrowband measurements, or over the frequency range from 100 Hz to 8000 Hz for wideband measurements, averaged over the entire duration of the test signal.
- Transform the DRP frequency spectrum measurement to the FF or DF (see ANSI/TIA-5050-2018 Annex B).
- Divide the 1/12 octave measurement data by the 1/12 octave frequency spectrum of the test signal at the RETP and present the measurement in terms of dB (Pa/V).
- Apply the applicable frequency response limits to determine compliance.
- If the default tone control setting does not meet the requirement, repeat the above steps for other tone control settings to determine a tone control setting that meets the requirements.
- Repeat with a mounting force of 2N.

7. Device Under Test

Normal operation	Held to head		
Back Cover	The Back Cover is not removable		
Test sample information	S/N K4VDY7MJ47	IMEI N/A	Notes HAC Sample

7.1. Air Interfaces and Operating Mode

All air interfaces which support voice capabilities over a managed CMRS were tested.

Air Interface	Bands (MHz)	Type	C63.19 Tested	Simultaneous Transmitter	Name of Voice Service	Power Mode ⁴	Power Reduction	Audio Codecs Evaluated ^{1,2}
GSM	850	VO	Yes	Wi-Fi, BT, NB U-NII, 802.15.4 & 802.15.4ab NB	CMRS	Mode A	N/A	EFR, AMR-NB & AMR-WB
	1900						N/A	
	GPRS/EDGE	DT/VD	No	Wi-Fi, BT, NB U-NII, 802.15.4 & 802.15.4ab NB	FaceTime	Mode A	N/A	ACC-ELD
W-CDMA (UMTS)	850	VO	Yes	Wi-Fi, BT, NB U-NII, 802.15.4 & 802.15.4ab NB	CMRS	Mode A	N/A	AMR-NB & AMR-WB
	1700							
	1900	VD	No	Wi-Fi, BT, NB U-NII, 802.15.4 & 802.15.4ab NB	FaceTime	Mode A	N/A	ACC-ELD
LTE - FDD	700 (B12/13/17)	VD	Yes	5G NR, Wi-Fi, BT, NB U-NII, 802.15.4 & 802.15.4ab NB	CMRS FaceTime	Mode A	N/A	AMR-NB, AMR-WB, EVS, & ACC-ELD
	850 (B5/26)							
	1700 (B4/66)							
	1900 (B2/25)							
	2300 (B30)							
2500 (B7)								
LTE - TDD	2500 (B53)	VD	Yes	5G NR, Wi-Fi, BT, NB U-NII, 802.15.4 & 802.15.4ab NB	CMRS FaceTime	Mode A	N/A	AMR-NB, AMR-WB, EVS, & ACC-ELD
	2600 (B41)							
	3600 (B48)							
5G NR(FR1) FDD	700 (n12)	VD	Yes ³	LTE, Wi-Fi, BT, NB U-NII, 802.15.4 & 802.15.4ab NB	CMRS FaceTime	Mode A	N/A	AMR-NB, AMR-WB, EVS, & ACC-ELD
	850 (n5/n26)							
	1700 (n66/n70)							
	1900 (n2/n25)							
	2300 (n30)							
2500 (n7)								
5G NR(FR1) TDD	2500 (n53)	VD	Yes ³	LTE, Wi-Fi, BT, NB U-NII, 802.15.4 & 802.15.4ab NB	CMRS FaceTime	Mode A	N/A	AMR-NB, AMR-WB, EVS, & ACC-ELD
	2600 (n41)							
	3500 (n77 Block A)							
	3700 (n48)							
	3900 (n77 Block C)							

Note(s):

- ASL of -20 dBm0 is required for all codecs.
- ACC-ELD not required for evaluation. Refer to §6.1.1(c).
- VoNR is supported: manufacturer states that VoNR uses the same protocol, Codec(s) and bitrates as VoLTE.
- For all air interfaces, the maximum held-to-head output power was used for Volume Control evaluations. The maximum held-to-head output power is Mode A for WWAN operating modes and Power State 1 Mode A for WLAN operating modes. Refer to §8 for Volume Control evaluations.

Type
 VO: Legacy Cellular Voice Service
 DT: Digital Transport only (no voice)
 VD: IP Voice Service over Digital Transport
 CMRS: Commercial Mobile Radio Service

Air Interfaces and Operating Modes

Air Interface	Bands (MHz)	Type	C63.19 Tested	Simultaneous Transmitter	Name of Voice Service	Power Mode ⁴	Power Reduction	Audio Codecs Evaluated ^{1,2}
Wi-Fi	2450	VD	Yes	WWAN, NB U-NII & 802.15.4ab	CMRS FaceTime	Power State 1 Mode A	N/A	AMR-NB, AMR-WB, EVS, & ACC-ELD
	U-NII-1							
	U-NII-2A							
	U-NII-2C							
	U-NII-3	VD	Yes	WWAN, BT, 802.15.4, & 802.15.4ab NB	CMRS FaceTime	Power State 1 Mode A	N/A	AMR-NB, AMR-WB, EVS, & ACC-ELD
	U-NII-5 (VLP, SP, LPI)							
	U-NII-6 (LPI)							
	U-NII-7 (VLP, SP, LPI)							
U-NII-8 (LPI)	VD	No ³	WWAN, BT, 802.15.4, & 802.15.4ab NB	CMRS FaceTime	N/A	N/A	AMR-NB, AMR-WB, EVS, & ACC-ELD	
NB U-NII	5200 (U-NII-1)	DT	N/A	WWAN, Wi-Fi 2.4 GHz	N/A	N/A	N/A	N/A
	5800 (U-NII-3)							
802.15ab NB	5800 (U-NII-3)	DT	N/A	WWAN, BT, 802.15.4 & Wi-Fi ²	N/A	N/A	N/A	N/A
802.15.4	2450	DT	N/A	WWAN, 802.15.4ab NB & Wi-Fi 5/6G	N/A	N/A	N/A	N/A
BT	2.4GHz	DT	N/A	WWAN, 802.15.4ab NB & Wi-Fi 5/6G	N/A	N/A	N/A	N/A
MSS	1600	DT	N/A	N/A	N/A	N/A	N/A	N/A
NFC	13	DT	N/A	WWAN, BT, Wi-Fi 2.4G, Wi-Fi 5/6G, 802.15.4	N/A	N/A	N/A	N/A
UWB (Ultra-Wideband)	6500	DT	N/A	N/A	N/A	N/A	N/A	N/A
	8000							

Note(s):

- ASL of -20 dBm0 is required for all codecs.
- ACC-ELD not required for evaluation. Refer to §6.1.1(c).
- Supported Frequency > 6GHz. ANSI C63,19 2019 only requires HAC evaluations for Technologies/Frequencies < 6GHz.
- For all air interfaces, the maximum held-to-head output power was used for Volume Control evaluations. The maximum held-to-head output power is Mode A for WWAN operating modes and Power State 1 Mode A for WLAN operating modes. Refer to §8 for Volume Control evaluations.

Type
VO: Legacy Cellular Voice Service
DT: Digital Transport only (no voice)
VD: IP Voice Service over Digital Transport
CMRS: Commercial Mobile Radio Service

8. HAC (Volume Control) Test Results

Volume control testing was performed in accordance with KDB 285076 D05 CG Interim Waiver DA 23-914. Test guidance is as follows:

- 1) Under the waiver, only CMRS narrowband and CMRS wideband voice codecs are required to comply with the volume control requirements of the TIA 5050-2018 Volume Control Standard as amended as follows:
 - a) For the 2N mounting force test, one narrowband and one wideband voice codec embedded with the handset must pass with at least one volume control setting with a conversational gain of ≥ 6 dB for all voice services, bands of operation and air interfaces over which it operates using one codec bit rate of the applicant's choosing.
 - i) With a mounting force of 2N, the ratio of the stimulus signal power to the 100 Hz to 8000 Hz total A-weighted distortion and noise power shall be ≥ 20 dB when tested over the range of 1/3 octave band center frequencies:
 - b) For the 8N mounting force test, one narrowband and one wideband voice codec embedded with the handset must pass with at least one volume control setting with a conversational gain of ≥ 6 dB for all voice services, bands of operation and air interfaces over which they operate but is not required to meet or exceed the full 18 dB of conversational gain specified in § 5.1.1 of the TIA 5050 Volume Control Standard using one codec bit rate of the applicant's choosing.
 - i) With a mounting force of 8N, the ratio of the stimulus signal power to the 100 Hz to 8000 Hz total A-weighted distortion and noise power shall be ≥ 20 dB when tested over the range of 1/3 octave band center frequencies:
- 2) For all other narrowband and wideband codecs not evaluated in 1) above, TIA 5050-2018 Receive Distortion and Noise Performance and Receive Acoustic Frequency Response Performance evaluations are not required; however, these codecs shall be assessed for conversational gain and documented in the test report at the 2N and 8N levels with a gain of ≥ 6 dB for all voice services, bands of operation and air interfaces over which they operate. The handset volume setting used to comply with 1) shall be used for these other CMRS codec evaluations.
- 3) Any other codec for voice services embedded in the handset, not identified in 1) and 2) above, is not required to comply or demonstrate in the test reports for conversational gain (e.g., Google Meet, non-3GPP VoIP codecs).

For WWAN technologies, the DUT utilizes an Antenna - Port mapping feature. A Port is a collection (cluster) of antennas. Once the Port and Frequency Band has been selected, the transmitting Antenna is auto selected. Below is a description of the Port - Antenna mapping for the DUT.

Port	Frequency Band	Antenna
A	LB	1
	LMB	1
	MBHB	1
	UHB	7
B	LB	2
	LMB	2
	MBHB	2
	UHB	8
C	MBHB	3
	UHB	9
D	MBHB	4
	UHB	4

LB = Lower Band (617 MHz - 960 MHz)
 LMB = Lower - Mid Band (1427 MHz - 1700 MHz)
 MBHB = Mid Band - High Band (1710 MHz - 2960 MHz)
 UHB = Ultra High Band (3300 MHz - 4200 MHz)

The device supports four (4) WLAN Tx antennas:

Antenna	Technology
3 (Lower)	Wi-Fi 2.4GHz
	Bluetooth
4 (Upper)	Wi-Fi 2.4GHz
	Bluetooth
5 (Lower)	Wi-Fi 5GHz
	Bluetooth
6 (Upper)	Wi-Fi 5GHz
	Bluetooth

Rx Distortion, Rx Frequency Response & Conversational Gain Measured Results

EVS-NB and EVS-WB codecs were selected for Rx Distortion, Rx Frequency Response & Conversational Gain evaluations.

LTE

RF Air Interface		Mode	Channel	Frequency (MHz)	Channel Bandwidth (MHz)	RB Allocation	RB Offset	Port/Antenna	Power Mode	Codec	Bitrate (kbps)	Frequency Response		Distortion		Conversational Gain (dB)		Plot No.
Technology	Band											2N DF	8N DF	2N SDNR	8N SDNR	2N	8N	
LTE	25	QPSK	26365	1882.5	20	1	0	A (ANT 1)	Mode A	EVS-NB	9.6	PASS	PASS	PASS	PASS	21.73	28.36	1 - 2
LTE	25	QPSK	26365	1882.5	20	1	0	A (ANT 1)	Mode A	EVS-WB	24.4	PASS	PASS	PASS	PASS	16.65	24.04	3 - 4
LTE	25	QPSK	26365	1882.5	20	100	0	A (ANT 1)	Mode A	EVS-WB	24.4	PASS	PASS	PASS	PASS	19.50	23.82	5 - 6
LTE	25	16QAM	26365	1882.5	20	1	0	A (ANT 1)	Mode A	EVS-WB	24.4	PASS	PASS	PASS	PASS	19.71	23.53	7 - 8
LTE	25	64QAM	26365	1882.5	20	1	0	A (ANT 1)	Mode A	EVS-WB	24.4	PASS	PASS	PASS	PASS	17.63	23.62	9 - 10
LTE	25	256QAM	26365	1882.5	20	1	0	A (ANT 1)	Mode A	EVS-WB	24.4	PASS	PASS	PASS	PASS	19.04	23.43	11 - 12
LTE	25	QPSK	26365	1882.5	1.4	1	0	A (ANT 1)	Mode A	EVS-WB	24.4	PASS	PASS	PASS	PASS	16.29	23.37	13 - 14
LTE	7	QPSK	21100	2535.0	5	1	0	A (ANT 1)	Mode A	EVS-WB	24.4	PASS	PASS	PASS	PASS	18.74	23.03	15 - 16
LTE	12	QPSK	23095	707.5	1.4	1	0	A (ANT 1)	Mode A	EVS-WB	24.4	PASS	PASS	PASS	PASS	18.87	23.45	17 - 18
LTE	13	QPSK	23230	782.0	5	1	0	A (ANT 1)	Mode A	EVS-WB	24.4	PASS	PASS	PASS	PASS	19.01	22.86	19 - 20
LTE	26	QPSK	26865	831.0	1.4	1	0	A (ANT 1)	Mode A	EVS-WB	24.4	PASS	PASS	PASS	PASS	18.74	22.62	21 - 22
LTE	30	QPSK	27710	2310.0	5	1	0	A (ANT 1)	Mode A	EVS-WB	24.4	PASS	PASS	PASS	PASS	16.08	23.69	23 - 24
LTE	41 PC3	QPSK	40620	2593.0	5	1	0	A (ANT 1)	Mode A	EVS-WB	24.4	PASS	PASS	PASS	PASS	18.23	23.31	25 - 26
LTE	41 PC2	QPSK	40620	2593.0	5	1	0	A (ANT 1)	Mode A	EVS-WB	24.4	PASS	PASS	PASS	PASS	18.48	23.11	27 - 28
LTE	48 PC3	QPSK	56990	3625.0	5	1	0	A (ANT 7)	Mode A	EVS-WB	24.4	PASS	PASS	PASS	PASS	18.78	23.52	29 - 30
LTE	53 PC3	QPSK	60197	2489.2	1.4	1	0	A (ANT 1)	Mode A	EVS-WB	24.4	PASS	PASS	PASS	PASS	16.98	23.41	31 - 32
LTE	66	QPSK	132322	1745.0	1.4	1	0	A (ANT 1)	Mode A	EVS-WB	24.4	PASS	PASS	PASS	PASS	18.02	23.25	33 - 34

5G NR

RF Air Interface		Mode	Channel	Frequency (MHz)	Channel Bandwidth (MHz)	SCS (kHz)	RB Allocation	RB Offset	Port/Antenna	Power Mode	Codec	Bitrate (kbps)	Frequency Response		Distortion		Conversational Gain (dB)		Plot No.
Technology	Band												2N DF	8N DF	2N SDNR	8N SDNR	2N	8N	
5G NR	n25	11/2 BPSK	376500	1882.5	40	15	1	1	A (ANT 1)	Mode A	EVS-NB	9.6	PASS	PASS	PASS	PASS	22.2	26.29	35 - 36
5G NR	n25	11/2 BPSK	376500	1882.5	40	15	1	1	A (ANT 1)	Mode A	EVS-WB	24.4	PASS	PASS	PASS	PASS	21.36	27.1	37 - 38
5G NR	n7	11/2 BPSK	507000	2535.0	40	15	1	1	A (ANT 1)	Mode A	EVS-WB	24.4	PASS	PASS	PASS	PASS	20.9	27.08	39 - 40
5G NR	n12	11/2 BPSK	141500	707.5	15	15	1	1	A (ANT 1)	Mode A	EVS-WB	24.4	PASS	PASS	PASS	PASS	23.51	27.01	41 - 42
5G NR	n41 PC3	11/2 BPSK	518598	2593.0	100	30	1	1	A (ANT 1)	Mode A	EVS-WB	24.4	PASS	PASS	PASS	PASS	20.27	27.32	43 - 44
5G NR	n41 PC2	11/2 BPSK	518598	2593.0	100	30	1	1	A (ANT 1)	Mode A	EVS-WB	24.4	PASS	PASS	PASS	PASS	19.95	27.09	45 - 46
5G NR	n77 Bk C PC2	11/2 BPSK	657200	3858.0	100	30	1	1	A (ANT 7)	Mode A	EVS-WB	24.4	PASS	PASS	PASS	PASS	22.88	27.04	47 - 48

Note(s):

The DUT supports 5G NR. Per the manufacturer, 5G NR uses the same protocol, Codec(s) and bitrates as LTE. A limited set of 5G NR bands were tested to confirm VoNR Volume Control compliance.

- At least one 5G NR-FDD LB, MB and HB were tested.
- At least one 5G NR-TDD HB and UIHB were tested.

WLAN

RF Air Interface		Modulation	Data Rate (Mbps)	Channel	Frequency (MHz)	Channel Bandwidth (MHz)	Antenna	Power Mode	Codec	Bitrate (kbps)	Frequency Response		Distortion		Conversational Gain (dB)		Plot No.	
Technology	Band										2N DF	8N DF	2N SDNR	8N SDNR	2N	8N		
WLAN	DTS	802.11b	CCK	5.5	6	2437.0	20	ANT 3	Power State 1 Mode A	EVS-NB	9.6	PASS	PASS	PASS	PASS	15.61	21.27	49 - 50
WLAN	DTS	802.11b	CCK	11	6	2437.0	20	ANT 3	Power State 1 Mode A	EVS-WB	24.4	PASS	PASS	PASS	PASS	14.92	22.83	51 - 52
WLAN	DTS	802.11g	QPSK	12	6	2437.0	20	ANT 3	Power State 1 Mode A	EVS-NB	9.6	PASS	PASS	PASS	PASS	13.84	21.53	53 - 54
WLAN	DTS	802.11n	MCS3	26	6	2437.0	20	ANT 3	Power State 1 Mode A	EVS-NB	9.6	PASS	PASS	PASS	PASS	15.88	21.61	55 - 56
WLAN	DTS	802.11ac	MCS3	26	6	2437.0	20	ANT 3	Power State 1 Mode A	EVS-NB	9.6	PASS	PASS	PASS	PASS	13.48	21.3	57 - 58
WLAN	DTS	802.11ax	MCS5	68.8	6	2437.0	20	ANT 3	Power State 1 Mode A	EVS-NB	9.6	PASS	PASS	PASS	PASS	13.24	21.04	59 - 60
WLAN	UNII-1	802.11a	QPSK	18	36	5180.0	20	ANT 5	Power State 1 Mode A	EVS-NB	9.6	PASS	PASS	PASS	PASS	13.51	21.62	61 - 62
WLAN	UNII-2A	802.11n	MCS3	54	54	5270.0	40	ANT 5	Power State 1 Mode A	EVS-NB	9.6	PASS	PASS	PASS	PASS	15.64	21.56	63 - 64
WLAN	UNII-2C	802.11ac	MCS5	234	106	5530.0	80	ANT 5	Power State 1 Mode A	EVS-NB	9.6	PASS	PASS	PASS	PASS	13.74	21.66	65 - 66
WLAN	UNII-3	802.11ax	MCS6	648.5	163	5815.0	160	ANT 5	Power State 1 Mode A	EVS-NB	9.6	PASS	PASS	PASS	PASS	13.42	22.83	67 - 68
WLAN	UNII-5	802.11ax	MCS5	68.8	5	5975.0	20	ANT 5	Power State 1 Mode A	EVS-NB	9.6	PASS	PASS	PASS	PASS	14.76	23.2	69 - 70

Note(s):

- For WLAN 2.4GHz, 802.11be has the same max output power, supports the same channel BWs (20MHz) and multiplexing as 802.11ax. Therefore, 802.11ax test results are representative of 802.11be.
- For WLAN 5/6GHz, 802.11be has the same max output power, supports the same channel BWs (20/40/80/160MHz) and multiplexing as 802.11ax. Therefore, 802.11ax test results are representative of 802.11be.

Conversational Gain Only Measured Results

The DUT supports EFR-NB, AMR-NB, and AMR-WB codecs. Per KDB 285076 D05 §2(b.), these codecs shall be assessed for conversational gain only.

GSM

RF Air Interface		Mode	Channel	Frequency (MHz)	Port/Antenna	Power Mode	Codec	Bitrate (kbps)	Conversational Gain (dB)	
Technology	Band								2N	8N
GSM	850	1 Slot Voice	190	836.6	A (ANT 1)	Mode A	EFR-NB	13.2	21.51	29.79
GSM	850	1 Slot Voice	190	836.6	A (ANT 1)	Mode A	AMR-NB	4.75	23.5	29.4
GSM	850	1 Slot Voice	190	836.6	A (ANT 1)	Mode A	AMR-WB	6.6	20.85	29.69
GSM	1900	1 Slot Voice	661	1880.0	A (ANT 1)	Mode A	AMR-WB	6.6	22.38	29.75

W-CDMA

RF Air Interface		Mode	Channel	Frequency (MHz)	Port/Antenna	Power Mode	Codec	Bitrate (kbps)	Conversational Gain (dB)	
Technology	Band								2N	8N
W-CDMA	II	Rel. 99	9400	1880.0	A (ANT 1)	Mode A	AMR-NB	4.75	20.72	28.83
W-CDMA	II	Rel. 99	9400	1880.0	A (ANT 1)	Mode A	AMR-WB	6.6	24.81	29.34
W-CDMA	IV	Rel. 99	1413	1732.6	A (ANT 1)	Mode A	AMR-NB	4.75	23.53	28.63
W-CDMA	V	Rel. 99	4183	836.6	A (ANT 1)	Mode A	AMR-NB	4.75	23.25	28.63

LTE

RF Air Interface		Mode	Channel	Frequency (MHz)	Channel Bandwidth (MHz)	RB Allocation	RB Offset	Port/Antenna	Power Mode	Codec	Bitrate (kbps)	Conversational Gain (dB)	
Technology	Band											2N	8N
LTE	25	QPSK	26365	1882.5	20	1	0	A (ANT 1)	Mode A	AMR-NB	4.75	19.85	28.66
LTE	25	QPSK	26365	1882.5	20	1	0	A (ANT 1)	Mode A	AMR-WB	6.6	20.44	28.54

5G NR

RF Air Interface		Mode	Channel	Frequency (MHz)	Channel Bandwidth (MHz)	SCS (kHz)	RB Allocation	RB Offset	Port/Antenna	Power Mode	Codec	Bitrate (kbps)	Conversational Gain (dB)	
Technology	Band												2N	8N
5G NR	n25	$\pi/2$ BPSK	376500	1882.5	40	15	1	1	A (ANT 1)	Mode A	AMR-NB	4.75	18.39	26.1
5G NR	n25	$\pi/2$ BPSK	376500	1882.5	40	15	1	1	A (ANT 1)	Mode A	AMR-WB	6.6	21.94	26.89

WLAN

RF Air Interface			Modulation	Data Rate (Mbps)	Channel	Frequency (MHz)	Channel Bandwidth (MHz)	Antenna	Power Mode	Codec	Bitrate (kbps)	Conversational Gain (dB)	
Technology	Band	Mode										2N	8N
WLAN	DTS	802.11b	DSSS	1	6	2437.0	20	ANT 3	Power State 1 Mode A	AMR-NB	4.75	13.91	21.11
WLAN	DTS	802.11b	DSSS	1	6	2437.0	20	ANT 3	Power State 1 Mode A	AMR-WB	23.85	13.91	22.38

Appendix

Refer to separated files for the following appendixes

Appendix A: Volume Control Setup Photo

Appendix B: Volume Control Test Plots

Appendix C: HAC Waiver DA 23-914

END OF REPORT