



**HAC RF EMISSIONS TEST REPORT**

**FCC 47 CFR § 20.19  
ANSI C63.19-2019**

*For*  
**SMARTPHONE**

**FCC ID: BCG-E8684A  
Model Name: A3084**

**Report Number: 14982479-S4V2  
Issue Date: 8/20/2024**

*Prepared for*  
**APPLE INC.  
1 APPLE PARK WAY  
CUPERTINO, CA 95014-2084**

*Prepared by*  
**UL VERIFICATION SERVICES INC.  
47173 BENICIA STREET  
FREMONT, CA 94538, U.S.A.  
TEL: (510) 319-4000  
FAX: (510) 661-0888**



CERT #0751.05

## Revision History

Rev.	Date	Revisions	Revised By
V1	7/31/2024	Initial Issue	--
V2	8/20/2024	Updated Sections 4.1/8/10/11. Appendices B/C/D/F/H	Coltyce Sanders

**Table of Contents**

**1. Attestation of Test Results..... 4**

**2. Test Methodology ..... 5**

**3. Facilities and Accreditation ..... 5**

**4. Calibration and Uncertainty ..... 6**

    4.1. *Measuring Instrument Calibration ..... 6*

    4.2. *Measurement Uncertainty..... 7*

**5. System Specifications ..... 9**

**6. System Validation ..... 10**

    6.1. *System Validation Results ..... 10*

**7. Device Under Test..... 11**

    7.1. *Air Interfaces and Operating Modes..... 11*

**8. Modulation Interference Factor (MIF) ..... 13**

**9. RF Emissions Measurement Criteria ..... 14**

**10. Evaluation for RF Audio Interference Power Level (RF<sub>AIPL</sub>) ..... 15**

**11. Evaluation for RF Audio Interference Level (RF<sub>AIL</sub>) ..... 20**

    11.1. *RF Audio Interference Level (RF<sub>AIL</sub>) Test Procedure ..... 20*

    11.2. *RF Audio Interference Level (RF<sub>AIL</sub>) Measured Results..... 23*

    11.3. *Worst Case RF<sub>AIL</sub> Test Plot..... 24*

**Appendixes ..... 25**

*Appendix A: RF-E Setup Photo ..... 25*

*Appendix B: RF-E System Validation Plots..... 25*

*Appendix C: RF-E Test Plots..... 25*

*Appendix D: RF-E MIF Attestation Letter..... 25*

*Appendix E: RF-E Probe Certificates..... 25*

*Appendix F: RF-E Dipole Certificates ..... 25*

*Appendix G: RF-E UID Specifications ..... 25*

*Appendix H: RF-E MIF Measurements ..... 25*

### 1. Attestation of Test Results



Applicant Name	APPLE, INC.
FCC ID	BCG-E8684A
Model Name	A3084
Applicable Standards	FCC 47 CFR § 20.19 ANSI C63.19-2019
Date Tested	7/9/2024 and 8/16/2024 to 8/20/2024
Test Results	Pass

UL Verification Services Inc. tested the above equipment in accordance with the requirements set forth in the above standards. The test results show that the equipment tested can demonstrate compliance with the requirements as documented in this report.

This report contains data provided by the customer which can impact the validity of results. UL Verification Services Inc. is only responsible for the validity of results after the integration of the data provided by the customer.

The results documented in this report apply only to the tested sample, under the conditions and modes of operation as described herein. It is the manufacturer's responsibility to assure that additional production units of this model are manufactured with identical electrical and mechanical components. All samples tested were in good operating condition throughout the entire test program. Measurement Uncertainties are published for informational purposes only and were not considered unless noted otherwise.

This document may not be altered or revised in any way unless done so by UL Verification Services Inc. and all revisions are noted in the revisions section. Any alteration of this document not carried out by UL Verification Services Inc. will constitute fraud and shall nullify the document. This report must not be used by the client to claim product certification, approval, or endorsement by A2LA, NIST, or any agency of the U.S. Government, or any agency of the U.S. government.

Approved & Released By: 	Prepared By: 
Devin Chang Senior Laboratory Engineer UL Verification Services Inc.	Coltyce Sanders Staff Laboratory Engineer UL Verification Services Inc.

## 2. Test Methodology

The tests documented in this report were performed in accordance with ANSI C63.19-2019 Methods of Measurement of Compatibility between Wireless Communications Devices and Hearing Aids and FCC Published procedure:

- KDB 285076 D01 HAC Guidance v06r04
- KDB 285076 D03 HAC FAQ v01r06
- TCB workshop updates

## 3. Facilities and Accreditation

47173 Benicia Street
SAR Lab H

UL Verification Services Inc. is accredited by A2LA, Certificate Number 0751.05

The Test Lab Conformity Assessment Body Identifier (CABID)

Location	CABID	Company Number
47173 Benicia Street, Fremont, CA, 94538 UNITED STATES	US0104	2324A
47266 Benicia Street, Fremont, CA, 94538 UNITED STATES		

## 4. Calibration and Uncertainty

### 4.1. Measuring Instrument Calibration

The measuring equipment utilized to perform the tests documented in this report has been calibrated in accordance with the manufacturer's recommendations, and is traceable to recognized national standards.

#### Test Equipment

Name of Equipment	Manufacturer	Type/Model	Serial No.	Cal. Due Date
Synthesized Signal Generator	R&S	SMB 100A	180970-zC	2/28/2025
Power Meter	Keysight	N1912A	MY55196008	1/31/2025
Power Sensor	Agilent	N1912A	MY53260001	1/31/2025
Power Sensor	Agilent	N1912A	MY52200012	1/31/2025
Bi-directional coupler	Mini-Circuits	ZUDC10-183+	1722	N/A
Data Acquisition Electronics	SPEAG	DAE4	1546	3/11/2025
E-Field Probe <sup>1</sup>	SPEAG	EF3DV3	4028	9/4/2024
Calibration Dipole	SPEAG	CD1880V3	1122	2/3/2025
Calibration Dipole	SPEAG	CD260V3	1014	9/5/2024
Calibration Dipole	SPEAG	CD3500V3	1006	11/10/2024
Radio Communication Tester	R&S	CMW 500	164541-Ci	2/28/2025
Modulation and Interference Analyzer	SPEAG	MAIA	1284	N/A
Spectrum Analyzer	Agilent	E4446A	MY45300064	2/28/2025

#### Note(s):

1. According to SPEAG's Technical Report, "MIF Verification", Doc # TR-FB-12.09.04-1, issued date: 9/4/2012. E-field probes are calibrated with specified uncertainty according to ISO 17025 as described in their calibration certificate. The MIF according to the definition in ANSI C63.19 is specific for a modulation and can therefore be used as a constant value if the probe has been PMR calibrated.
2. In accordance with UL Quality Policy ULID-008202, reference dipoles need only be returned to the system manufacturer for calibration every three years. The dipole target, impedance and return loss must be checked at least yearly by the test laboratory and compared to the calibration certificate. If any of these parameters deviate by more than that permitted by UL Quality Policy ULID-008202 then the dipole shall be withdrawn from use and return to the manufacturer for immediate re-calibration. Refer to Appendix F of this report for both the calibration certificates and the in-house checks (where appropriate).

### 4.2. Measurement Uncertainty

Error Description	Uncertainty value (±%)	Probe Dist.	Div.	(C <sub>i</sub> ) E	Std. Unc.(±%) E
<b>Measurement System</b>					
Probe Calibration	5.1	N	1	1	5.1
Axial Isotropy	4.7	R	1.732	1	2.7
Sensor Displacement	7.2	R	1.732	1	4.2
Boundary Effects	2.4	R	1.732	1	1.4
Linearity	4.7	R	1.732	1	2.7
Scaling to Peak Power with MIF	0.0	R	1.732	1	0.0
System Detection Limit	1.0	R	1.732	1	0.6
Readout Electronics	0.3	N	1	1	0.3
Response Time	0.0	R	1.732	1	0.0
Integration Time	0.0	R	1.732	1	0.0
RF Ambient Conditions	3.0	R	1.732	1	1.7
RF Reflections	12.0	R	1.732	1	6.9
Probe Positioner	1.2	R	1.732	1	0.7
Probe Positioning	3.0	R	1.732	1	1.7
Extrapolation and Interpolation	1.0	R	1.732	1	0.6
<b>Dipole Related</b>					
Dist. Dipole - Scan Plane	5.2	R	1.732	1	3.0
Input Power	4.7	N	1	1	4.7
Combined Std. Uncertainty					12.1
<b>Expanded Std. Uncertainty on Power (Coverage Factor for 95%, k = 2)</b>					<b>24.2</b>
<b>Expanded Std. Uncertainty on Field</b>					<b>12.1</b>
Notes for table					
1. N - Nomal					
2. R - Rectangular					
3. Div. - Divisor used to obtain standard uncertainty					
4. C <sub>i</sub> - is the sensitivity coefficient					

Error Description	Uncertainty value ( $\pm\%$ )	Probe Dist.	Div.	(C) <sub>i</sub> E	Std. Unc.( $\pm\%$ ) E
<b>Measurement System</b>					
Probe Calibration	5.1	N	1	1	5.1
Axial Isotropy	4.7	R	1.732	1	2.7
Sensor Displacement	7.2	R	1.732	0.5	2.1
Boundary Effects	2.4	R	1.732	1	1.4
Phantom Boundary Effect	7.2	R	1.732	1	4.2
Probe Linearity	4.7	R	1.732	1	2.7
Scaling to Peak Power with MIF	10.0	R	1.732	1	5.8
System Detection Limit	1.0	R	1.732	1	0.6
Readout Electronics	0.3	N	1	1	0.3
Response Time	0.8	R	1.732	0	0
Integration Time	2.6	R	1.732	0	0
RF Ambient Conditions	3.0	R	1.732	1	1.7
RF Reflections	12.0	R	1.732	1	6.9
Probe Positioner	1.2	R	1.732	1	0.7
Probe Positioning	3.0	R	1.732	1	1.7
Extrapolation and Interpolation	1.0	R	1.732	1	0.6
<b>Test sample Related</b>					
Device Positioning Vertical	4.7	R	1.732	1	2.7
Device Positioning Lateral	1.0	R	1.732	1	0.6
Device Holder and Phantom	2.4	R	1.732	1	1.4
Power Drift	5.0	R	1.732	1	2.9
<b>Phantom and Setup Related</b>					
Phantom Thickness	2.4	R	1.732	1	1.4
Combined Std. Uncertainty					13.1
<b>Expanded Std. Uncertainty on Power (Coverage Factor for 95%, k = 2)</b>					<b>26.3</b>
<b>Expanded Std. Uncertainty on Field</b>					<b>13.1</b>
Notes for table					
1. N - Nomal					
2. R - Rectangular					
3. Div. - Divisor used to obtain standard uncertainty					
4. C <sub>i</sub> - is the Sensitivity coefficient					



## 5. System Specifications

E-field measurements are performed using the DASY6<sup>1</sup> automated dosimetric assessment system. The DASY6 is made by Schmid & Partner Engineering AG (SPEAG) in Zurich, Switzerland.

The DASY6 HAC Extension consists of the following parts:

### Test Arch Phantom

The specially designed Test Arch allows high precision positioning of both the device and any of the validation dipoles.

#### EF3DV3 Isotropic E-Field Probe

- Construction:
- One dipole parallel, two dipoles normal to probe axis
  - Built-in shielding against static charges
  - PEEK enclosure material
- Calibration:
- In air from 100 MHz to 3.0 GHz (absolute accuracy  $\pm 6.0\%$ ,  $k=2$ )
  - ISO/IEC 17025 [calibration service](#) available.
- Frequency:
- 40 MHz – >6 GHz (can be extended to < 20 MHz)
  - Linearity:  $\pm 0.2$  dB (100 MHz – 3 GHz)
- Directivity:
- $\pm 0.2$  dB in air (rotation around probe axis)
  - $\pm 0.4$  dB in air (rotation normal to probe axis)
- Dynamic Range:
- 2 V/m to > 1000 V/m; Linearity:  $\pm 0.2$  dB
- Dimensions:
- Overall length: 337 mm (Tip: 20 mm)
  - Tip diameter: 3.9 mm (Body: 12 mm)
  - Distance from probe tip to dipole centers: 1.5 mm
  - Sensor displacement to probe's calibration point: <0.7 mm
- Application:
- General near-field measurements up to 6 GHz
  - HAC measurements up to 6 GHz
  - Field component measurements
  - Fast automatic scanning in phantoms

---

<sup>1</sup> DASY6: v1.2.0.1713 and older generations.

## 6. System Validation

The test setup was validated when first configured and verified periodically thereafter to ensure proper function. The procedure provided in this section is a validation procedure using dipole antennas for which the field levels were computed by numeric modeling.

Procedure:

- Place a dipole antenna meeting the requirements given in ANSI C63.19 in the normally occupied by the WD.
- The dipole antenna serves as a known source for an electrical and magnetic output. Position the E-field probe so that the following occurs:
  - The probes and their cables are parallel to the coaxial feed of the dipole antenna
  - The probe cables and the coaxial feed of the dipole antenna approach the measurement area from opposite directions
  - The center point of the probe element(s) is 15 mm from the closest surface of the dipole elements.
- Scan the length of the dipole with the E-field probe and record the two maximum values found near the dipole ends. Average the two readings and compare the reading to the expected value in the calibration certificate or the expected value in this standard.

### Setup diagram

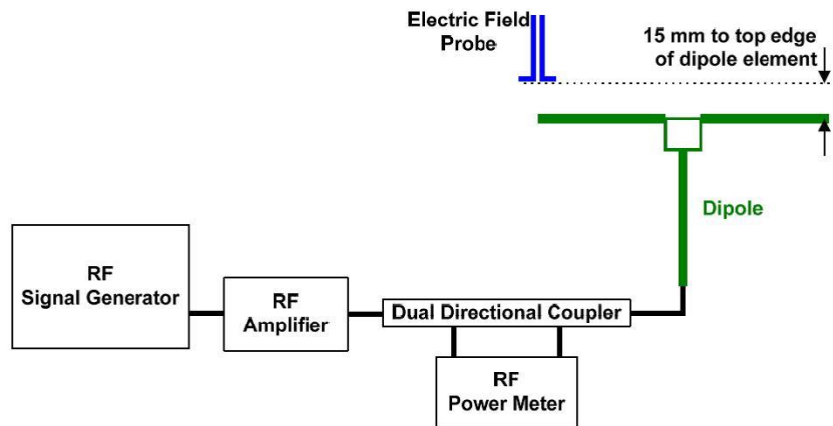

### 6.1. System Validation Results

SAR Lab	Date	Dipole Type_Serial #_Center Freq.	Dipole Cal. Due Data	E-Field Measured (V/m)	E-Field Target (V/m) (From SPEAG)	E-Field <sup>1</sup> Delta ± %	Plot No.
H	7/9/2024	CD1880V3_SN:1122_(1880 MHz)	2/3/2025	82.4	86.60	-4.85	1
H	8/19/2024	CD2600V3_SN:1014_(2600 MHz)	9/5/2024	81.7	86.30	-5.33	2
H	8/19/2024	CD3500V3_SN:1006_(3500 MHz)	11/10/2024	79.5	83.40	-4.68	3

**Note(s):**

1. Delta (Deviation) % = 100 \* (Measured value minus Target value) divided by the Target value. Deltas within ±18% are acceptable, of which 12% is deviation and 13% is measurement uncertainty.

### 7. Device Under Test

Normal operation	Held to head		
Back Cover	The Back Cover is not removable		
Test sample information	S/N	IMEI	Notes
	LXNYH61XWY	N/A	HAC Sample
	C7NH3G9LQR	N/A	HAC Sample

#### 7.1. Air Interfaces and Operating Modes

Air Interface	Bands (MHz)	Type	C63.19 Tested	Simultaneous Transmitter	Name of Voice Service	Power Mode <sup>3,4</sup>	Power Reduction
GSM	850	VO	No <sup>1</sup>	Wi-Fi, BT, NB U-NII, 802.15.4 & 802.15.4ab NB	CMRS	Max Power & Mode A	N/A
	1900		Yes <sup>2</sup>				N/A
	850 GPRS/EDGE	DT/VD	No <sup>1</sup>	Wi-Fi, BT, NB U-NII, 802.15.4 & 802.15.4ab NB	FaceTime	Max Power & Mode A	N/A
	1900 GPRS/EDGE	DT/VD	Yes <sup>2</sup>				N/A
W-CDMA (UMTS)	850	VO	No <sup>1</sup>	Wi-Fi, BT, NB U-NII, 802.15.4 & 802.15.4ab NB	CMRS	Max Power & Mode A	N/A
	1700						
	1900	VD	No <sup>1</sup>	Wi-Fi, BT, NB U-NII, 802.15.4 & 802.15.4ab NB	FaceTime	Max Power & Mode A	N/A
HSPA							
LTE - FDD	600 (B71)	VD	No <sup>1</sup>	5G NR, Wi-Fi, BT, NB U-NII, 802.15.4 & 802.15.4ab NB	CMRS FaceTime	Max Power & Mode A	N/A
	700 (B12/13/14/17)						
	850 (B5/26)						
	1700 (B4/66)						
	1900 (B2/25)						
	2300 (B30)						
2500 (B7)							
LTE - TDD	2500 (B53)	VD	No <sup>1</sup>	5G NR, Wi-Fi, BT, NB U-NII, 802.15.4 & 802.15.4ab NB	CMRS FaceTime	Max Power & Mode A	N/A
	2600 (B41)						
	3600 (B48)						
5G NR(FR1) FDD	600 (n71)	VD	No <sup>1</sup>	LTE, Wi-Fi, BT, NB U-NII, 802.15.4 & 802.15.4ab NB	CMRS FaceTime	Max Power & Mode A	N/A
	700 (n12/n14)						
	850 (n5/n26)						
	1700 (n66/n70)						
	1900 (n2/n25)						
	2300 (n30)						
2500 (n7)							
5G NR(FR1) TDD <sup>5</sup>	2500 (n53)	VD	No <sup>1</sup>	LTE, Wi-Fi, BT, NB U-NII, 802.15.4 & 802.15.4ab NB	CMRS FaceTime	Max Power & Mode A	N/A
	2600 (n41)						
	3500 (n77 Block A)						
	3700 (n48)						
	3900 (n77 Block C)						

Type  
 VO: Legacy Cellular Voice Service  
 DT: Digital Transport only (no voice)  
 VD: IP Voice Service over Digital Transport  
 CMRS: Commercial Mobile Radio Service

- Note:
1. Evaluated for RF<sub>AIPL</sub>. Refer to §10.
  2. Evaluated for RF<sub>AIL</sub>. Refer to §11.
  3. For all air interfaces, the declared maximum output across all power tables, including held-to-head, off-body and body-worn, was used for the RF<sub>AIPL</sub> evaluation. The declared maximum output power is Max Power for WWAN operating modes and Max Power for WLAN operating modes. Refer to §10 for RF<sub>AIPL</sub> evaluations.
  4. For all air interfaces, the maximum held-to-head output power was used for the RF<sub>AIL</sub> evaluation. The maximum held-to-head output power is Mode A for WWAN operating modes and Power State 1 Mode A for WLAN operating modes. Refer to §11 for RF<sub>AIL</sub> evaluations.
  5. UL MIMO supported for 5G NR n41(PC1.5)/n77(PC1.5)/n48(PC3)

**Air Interfaces and Operating Modes**

Air Interface	Bands (MHz)	Type	C63.19 Tested	Simultaneous Transmitter	Name of Voice Service	Power Mode <sup>3,4,5</sup>	Power Reduction
Wi-Fi	2450	VD	No <sup>1</sup>	WWAN, NB U-NII & 802.15.4ab	CMRS FaceTime	Max Power & Power State 1 Mode A	N/A
	U-NII-1						
	U-NII-2A						
	U-NII-2C						
	U-NII-3	VD	No <sup>1</sup>	WWAN, BT, 802.15.4, & 802.15.4ab NB	CMRS FaceTime	Max Power & Power State 1 Mode A	N/A
	U-NII-5 (VLP, SP, LPI)						
	U-NII-6 (LPI)						
	U-NII-7 (VLP, SP, LPI)						
	U-NII-8 (LPI)	VD	No <sup>2</sup>	WWAN, BT, 802.15.4, & 802.15.4ab NB	CMRS FaceTime	N/A	N/A
NB U-NII	5200 (U-NII-1)			DT			
	5800 (U-NII-3)						
802.15ab NB	5800 (U-NII-3)	DT	N/A	WWAN, BT, 802.15.4 & Wi-Fi <sup>2</sup>	N/A	N/A	N/A
802.15.4	2450	DT	N/A	WWAN, 802.15.4ab NB & Wi-Fi 5/6G	N/A	N/A	N/A
BT	2.4GHz	DT	N/A	WWAN, 802.15.4ab NB & Wi-Fi 5/6G	N/A	N/A	N/A
MSS	1600	DT	N/A	N/A	N/A	N/A	N/A
NFC	13	DT	N/A	WWAN, BT, Wi-Fi 2.4G, Wi-Fi 5/6G, 802.15.4	N/A	N/A	N/A
UWB (Ultra-Wideband)	6500	DT	N/A	N/A	N/A	N/A	N/A
	8000						

Type  
 VO: Legacy Cellular Voice Service  
 DT: Digital Transport only (no voice)  
 VD: IP Voice Service over Digital Transport  
 CMRS: Commercial Mobile Radio Service

Note:

1. Evaluated for RF<sub>AIPL</sub>. Refer to §10.
2. Supported Frequency > 6GHz. ANSI C63.19 2019 only requires HAC evaluations for Technologies/Frequencies < 6GHz.
3. For all air interfaces, the declared maximum output across all power tables, including held-to-head, off-body and body-worn, was used for the RF<sub>AIPL</sub> evaluation. The declared maximum output power is Max Power for WWAN operating modes and Max Power for WLAN operating modes. Refer to §10 for RF<sub>AIPL</sub> evaluations.
4. For all air interfaces, the maximum held-to-head output power was used for the RF<sub>AIL</sub> evaluation. The maximum held-to-head output power is Mode A for WWAN operating modes and Power State 1 Mode A for WLAN operating modes. Refer to §11 for RF<sub>AIL</sub> evaluations.
5. Refer to UL SAR FCC Report 14982479-S1 for WLAN Max Output power values.

## 8. Modulation Interference Factor (MIF)

A WD's interference potential is a function of both the WD's average in-use near-field field strength and of the signal's audio-frequency amplitude modulation characteristics. The portion of the interference potential attributable to the modulation characteristic can be evaluated independently of any particular WD. This evaluation of this interference potential relative to a signal's average field strength is described in D.7 and is termed its Modulation Interference Factor (MIF). The MIF may be determined through analysis and simulation, allowing evaluation of an RF technology's RF interference potential in advance of actual product development.

The evaluation method or the MIF is defined in ANSI C63.19 section D.7. Most MIF values were not tested by a probe or as specified in the standards but are based on analysis provided by SPEAG for all the air interfaces (GSM, WCDMA, LTE, 5G NR, and Wi-Fi). For operating modes in which SPEAG did not provide MIF values, test lab manually performed MIF measurements using procedure outlined in *SPEAG DASY6 Module HAC System Handbook §7.1 MIF Measurements with MAIA*. The data included in this report are for the worst case operating modes. The UIDs used are listed below:

UID	Communication System Name	MIF (dB)
10021-DAC	GSM-FDD (TDMA, GMSK)	3.63
10023-DAC	GPRS-FDD (TDMA, GMSK, TN 0)	3.80
10024-DAC	GPRS-FDD (TDMA, GMSK, TN 0-1)	1.15
10011-CAC	UMTS-FDD (WCDMA)	-27.23
10225-CAC	UMTS-FDD (HSPA+)	-20.39
10170-CAF	LTE-FDD (SC-FDMA, 1 RB, 20 MHz, 16QAM)	-9.76
10182-CAF	LTE-FDD (SC-FDMA, 1 RB, 15 MHz, 16QAM)	-9.76
10176-CAH	LTE-FDD (SC-FDMA, 1 RB, 10 MHz, 16QAM)	-9.76
10173-CAH	LTE-TDD (SC-FDMA, 1 RB, 20 MHz, 16QAM)	-1.44
10235-CAH	LTE-TDD (SC-FDMA, 1 RB, 10 MHz, 16QAM)	-1.44
10061-CAB	IEEE 802.11b WiFi 2.4 GHz (DSSS, 11 Mbps)	-2.02
10077-CAB	IEEE 802.11g WiFi 2.4 GHz (DSSS/OFDM, 54 Mbps)	0.12
10069-CAD	IEEE 802.11a/h WiFi 5 GHz (OFDM, 54 Mbps)	-3.15
10317-AAE	IEEE 802.11a WiFi 5 GHz (OFDM, 6 Mbps, 96pc duty cycle)	-9.82
10591-AAD	IEEE 802.11n (HT Mixed, 20MHz, MCS0, 90pc duty cycle)	-5.59
10636-AAE	IEEE 802.11ac WiFi (160MHz, MCS0, 90pc duty cycle)	-5.56
10671-AAC	IEEE 802.11ax/be (20MHz, MCS0, 90pc duty cycle)	-5.58
10797-AAF	5G NR (CP-OFDM, 1 RB, 40 MHz, QPSK, 30 kHz)	-14.32
10803-AAF	5G NR (CP-OFDM, 1 RB, 100 MHz, QPSK, 30 kHz)	-14.38
N/A*	5G NR PC2 (CP-OFDM, 1 RB, 100 MHz, QPSK, 30 kHz)	-1.77
N/A*	5G NR PC1.5 (CP-OFDM, 1 RB, 100 MHz, QPSK, 30 kHz)	0.47
10866-AAD	5G NR (DFT-s-OFDM, 1 RB, 100 MHz, QPSK, 30 kHz)	-16.69
N/A*	5G NR PC2 (DFT-s-OFDM, 50 RB, 100 MHz, BPSK, 30 kHz)	-1.16
N/A*	5G NR PC1.5 (DFT-s-OFDM, 50 RB, 100 MHz, BPSK, 30 kHz)	1.14
N/A*	5G NR PC2 (DFT-s-OFDM, 1 RB, 100 MHz, QPSK, 30 kHz)	-1.31
N/A*	5G NR PC1.5 (DFT-s-OFDM, 1 RB, 100 MHz, QPSK, 30 kHz)	0.96
10898-AAB	5G NR (DFT-s-OFDM, 1 RB, 10 MHz, QPSK, 30 kHz)	-16.68
10903-AAB	5G NR (DFT-s-OFDM, 1 RB, 40 MHz, QPSK, 30 kHz)	-16.68
10929-AAC	5G NR (DFT-s-OFDM, 1 RB, 10 MHz, QPSK, 15 kHz)	-15.06
10930-AAC	5G NR (DFT-s-OFDM, 1 RB, 15 MHz, QPSK, 15 kHz)	-15.06
10931-AAC	5G NR (DFT-s-OFDM, 1 RB, 20 MHz, QPSK, 15 kHz)	-15.06
10932-AAC	5G NR (DFT-s-OFDM, 1 RB, 25 MHz, QPSK, 15 kHz)	-15.06
10933-AAC	5G NR (DFT-s-OFDM, 1 RB, 30 MHz, QPSK, 15 kHz)	-15.06
10934-AAC	5G NR (DFT-s-OFDM, 1 RB, 40 MHz, QPSK, 15 kHz)	-15.07
10935-AAD	5G NR (DFT-s-OFDM, 1 RB, 50 MHz, QPSK, 15 kHz)	-15.07

### Note(s):

- Refer to Appendix G for RF-E UID Specifications summary provided by SPEAG.
- \*Refer to Appendix H for MIF measurements conducted by test lab for 5G NR TDD Power Class 2 and Power Class 1.5

## 9. RF Emissions Measurement Criteria

The WD's conducted power must be at or below either the stated  $RF_{A IPL}$  (Table 4.1) or the stated peak power level (Table 4.2), or the average near-field emissions over the measurement area must be at or below the stated  $RF_{A IL}$  (Table 4.3), or the stated peak field strength (Table 4.4). The WD may demonstrate compliance by meeting any of these four requirements, but it must do so in each of its operating bands at its established worst-case normal speech-mode operating condition.

**Table 4.1 - Wireless device RF audio interference power level**

Frequency Range (MHz)	$RF_{A IPL}$ (dBm)
< 960	29
960 – 2000	26
> 2000	25

**Table 4.2 - Wireless device RF peak power level**

Frequency Range (MHz)	$RF_{Peak Power}$ (dBm)
< 960	35
960 – 2000	32
> 2000	31

**Table 4.3 - Wireless device RF audio interference level**

Frequency Range (MHz)	$RF_{A IL}$ [dB(V/m)]
≤ 960	39
960 – 2000	36
> 2000	35

**Table 4.4 - Wireless device RF peak near-field level**

Frequency Range (MHz)	$RF_{peak}$ [dB(V/m)]
≤ 960	45
960 – 2000	42
> 2000	41

### 10. Evaluation for RF Audio Interference Power Level (RF<sub>AIPL</sub>)

An RF air interface technology of a device is exempt from testing when its average antenna input power plus its MIF is at or below the RF<sub>AIPL</sub> listed in the table below (from ANSI C63.19 2019 §4.7) for any of its operating modes. If a device supports multiple RF air interfaces, each RF air interface shall be evaluated individually.

**Table 4.1—Wireless device RF audio interference power level**

Frequency Range (MHz)	RF <sub>AIPL</sub> (dBm)
< 960	29
960 – 2000	26
> 2000	25

For all air interfaces, the declared maximum output across all power tables, including held-to-head, off-body and body-worn, was used for the RF<sub>AIPL</sub> evaluation. The declared maximum output power is Max Power for WWAN operating modes and Max Power for WLAN operating modes.

#### ANT 1

Air-Interface	Frequency Range	Multiplex Scheme	Modulation	BW (MHz)	SCS (kHz)	Power Mode	Max Output Power (dBm)	Duty Cycle	Average Frame Power (dBm)	Worst Case MIF (dB)	RF <sub>AIPL</sub> (dBm)	RF <sub>AIPL</sub> Limit (dBm)	HAC RF <sub>AIL</sub> Required
GSM850	824.2 - 848.8	TDMA	GMSK	NA	NA	Max Power	33.5	12.5%	24.5	3.80	28.3	29	No
GSM850	824.2 - 848.8	TDMA	GMSK	NA	NA	Max Power	32.5	25%	26.5	1.15	27.6	29	No
GSM1900	1850.2 - 1909.8	TDMA	GMSK	NA	NA	Max Power	32.0	12.5%	23.0	3.80	26.8	26	Yes
GSM1900	1850.2 - 1909.8	TDMA	GMSK	NA	NA	Max Power	31.0	25%	25.0	1.15	26.1	26	Yes
W-CDMA Band II	1850 - 1910	FDD	HSPA+	NA	NA	Max Power	25.7	100%	25.7	-20.39	5.3	26	No
W-CDMA Band IV	1710 - 1755	FDD	HSPA+	NA	NA	Max Power	25.7	100%	25.7	-20.39	5.3	26	No
W-CDMA Band V	824 - 849	FDD	HSPA+	NA	NA	Max Power	25.7	100%	25.7	-20.39	5.3	29	No
LTE Band 2	1850 - 1910	FDD SC-FDMA	16-QAM	20	NA	Max Power	25.7	100%	25.7	-9.76	15.9	26	No
LTE Band 4	1710 - 1755	FDD SC-FDMA	16-QAM	20	NA	Max Power	25.7	100%	25.7	-9.76	15.9	26	No
LTE Band 5	824 - 849	FDD SC-FDMA	16-QAM	10	NA	Max Power	25.7	100%	25.7	-9.76	15.9	29	No
LTE Band 7	2500 - 2570	FDD SC-FDMA	16-QAM	20	NA	Max Power	25.7	100%	25.7	-9.76	15.9	25	No
LTE Band 12	699 - 716	FDD SC-FDMA	16-QAM	10	NA	Max Power	25.7	100%	25.7	-9.76	15.9	29	No
LTE Band 13	777 - 787	FDD SC-FDMA	16-QAM	10	NA	Max Power	25.7	100%	25.7	-9.76	15.9	29	No
LTE Band 14	788 - 798	FDD SC-FDMA	16-QAM	10	NA	Max Power	25.7	100%	25.7	-9.76	15.9	29	No
LTE Band 17	704 - 716	FDD SC-FDMA	16-QAM	10	NA	Max Power	25.7	100%	25.7	-9.76	15.9	29	No
LTE Band 25	1850 - 1915	FDD SC-FDMA	16-QAM	20	NA	Max Power	25.7	100%	25.7	-9.76	15.9	26	No
LTE Band 26	814 - 849	FDD SC-FDMA	16-QAM	15	NA	Max Power	25.7	100%	25.7	-9.76	15.9	29	No
LTE Band 30	2305 - 2315	FDD SC-FDMA	16-QAM	10	NA	Max Power	25.7	100%	25.7	-9.76	15.9	25	No
LTE Band 41 PC3	2496 - 2690	TDD SC-FDMA	16-QAM	20	NA	Max Power	25.7	63.3%	23.7	-1.44	22.3	25	No
LTE Band 41 PC2	2496 - 2690	TDD SC-FDMA	16-QAM	20	NA	Max Power	28.7	43.3%	25.1	-1.44	23.6	25	No
LTE Band 53 PC3	2483.5 - 2495	TDD SC-FDMA	16-QAM	20	NA	Max Power	20.7	63.3%	18.7	-1.44	17.3	25	No
LTE Band 66	2110 - 2200	FDD SC-FDMA	16-QAM	20	NA	Max Power	25.7	100%	25.7	-9.76	15.9	25	No
LTE Band 71	617 - 652	FDD SC-FDMA	16-QAM	20	NA	Max Power	25.7	100%	25.7	-9.76	15.9	29	No
5G NR Band n2	1850 - 1910	FDD DFT-s-OFDM	QPSK	40	15	Max Power	25.7	100%	25.7	-15.07	10.6	26	No
5G NR Band n5	824 - 849	FDD DFT-s-OFDM	QPSK	25	15	Max Power	25.7	100%	25.7	-15.06	10.6	29	No
5G NR Band n7	2500 - 2570	FDD DFT-s-OFDM	QPSK	50	15	Max Power	25.7	100%	25.7	-15.07	10.6	25	No
5G NR Band n12	699 - 716	FDD DFT-s-OFDM	QPSK	15	15	Max Power	25.7	100%	25.7	-15.06	10.6	29	No
5G NR Band n14	788 - 798	FDD DFT-s-OFDM	QPSK	10	15	Max Power	25.7	100%	25.7	-15.06	10.6	29	No
5G NR Band n25	1850 - 1915	FDD DFT-s-OFDM	QPSK	40	15	Max Power	25.7	100%	25.7	-15.07	10.6	26	No
5G NR Band n26	814 - 849	FDD DFT-s-OFDM	QPSK	30	15	Max Power	25.7	100%	25.7	-15.06	10.6	29	No
5G NR Band n30	2305 - 2315	FDD DFT-s-OFDM	QPSK	10	15	Max Power	25.2	100%	25.2	-15.06	10.1	25	No
5G NR Band n41 PC3	2496 - 2690	TDD DFT-s-OFDM	QPSK	100	30	Max Power	25.7	100%	25.7	-16.69	9.0	25	No
5G NR Band n41 PC2	2496 - 2690	TDD CP-OFDM	QPSK	100	30	Max Power	24.2	100%	24.2	-14.38	9.8	25	No
5G NR Band n41 PC2	2496 - 2690	TDD DFT-s-OFDM	π/2 BPSK	100	30	Max Power	28.7	50%	25.7	-1.16	24.5	25	No
5G NR Band n41 PC2	2496 - 2690	TDD CP-OFDM	QPSK	100	30	Max Power	27.2	50%	24.2	-1.77	22.4	25	No
5G NR Band n41 UL MIMO PC1.5	2496 - 2690	TDD DFT-s-OFDM	π/2 BPSK	100	30	Max Power	31.2	25%	25.2	1.14	26.3	25	Yes
5G NR Band n41 UL MIMO PC1.5	2496 - 2690	TDD CP-OFDM	QPSK	100	30	Max Power	29.7	25%	23.7	0.47	24.1	25	No
5G NR Band n53 PC3	2484 - 2495	TDD DFT-s-OFDM	QPSK	100	30	Max Power	20.7	100%	20.7	-16.69	4.0	25	No
5G NR Band n53 PC3	2484 - 2495	TDD CP-OFDM	QPSK	100	30	Max Power	19.2	100%	19.2	-14.38	4.8	25	No
5G NR Band n66	2110 - 2200	FDD DFT-s-OFDM	QPSK	40	15	Max Power	25.7	100%	25.7	-15.07	10.6	25	No
5G NR Band n70	1695 - 1710	FDD DFT-s-OFDM	QPSK	25	15	Max Power	25.7	100%	25.7	-15.06	10.6	26	No
5G NR Band n71	617 - 652	FDD DFT-s-OFDM	QPSK	30	15	Max Power	25.7	100%	25.7	-15.06	10.6	29	No

**Note(s):**

- Average Antenna Input power = Average Frame power in order to account for the Operating Duty cycles for each respective Air Interface.
- Worst Case MIF = the Highest MIF value for each respective RF Air Interface.
- For operating modes where Average Antenna Input power plus MIF is below RF<sub>AIPL</sub>, they are compliant to RF<sub>AIPL</sub> requirements.
  - For operating modes where Average Antenna Input power plus MIF is above RF<sub>AIPL</sub>, they were evaluated to RF<sub>AIL</sub> requirements. Refer to §11 for RF<sub>AIL</sub> Evaluations.

ANT 2

Table with 14 columns: Air-Interface, Frequency Range, Multiplex Scheme, Modulation, BW (MHz), SCS (kHz), Power Mode, Max Output Power (dBm), Duty Cycle, Average Frame Power (dBm), Worst Case MIF (dB), RF\_AIRL (dBm), RF\_AIRL Limit (dBm), HAC RF\_AIRL Required. Rows include GSM850, GSM1900, W-CDMA Band II, LTE Band 2-14, 5G NR Bands n2-n7, n12-n14, n25, n26, n30, n41 PC3, n41 PC2, n41 PC2, n41 PC2, n41 UL MIMO PC1.5, n41 UL MIMO PC1.5, n53 PC3, n53 PC3, n66, n70, n71.

Note(s):

- Average Antenna Input power = Average Frame power in order to account for the Operating Duty cycles for each respective Air Interface.
Worst Case MIF = the Highest MIF value for each respective RF Air Interface.
For operating modes where Average Antenna Input power plus MIF is below RF\_AIRL, they are compliant to RF\_AIRL requirements.
For operating modes where Average Antenna Input power plus MIF is above RF\_AIRL, they were evaluated to RF\_AIRL requirements. Refer to §11 for RF\_AIRL Evaluations.

ANT 3

Table with 14 columns: Air-Interface, Frequency Range, Multiplex Scheme, Modulation, BW (MHz), SCS (kHz), Power Mode, Max Output Power (dBm), Duty Cycle, Average Frame Power (dBm), Worst Case MIF (dB), RF\_AIRL (dBm), RF\_AIRL Limit (dBm), HAC RF\_AIRL Required. Rows include GSM1900, W-CDMA Band II, W-CDMA Band IV, LTE Band 2-7, 5G NR Bands n2, n7, n25, n30, n41 PC3, n41 PC2, n41 PC2, n41 UL MIMO PC1.5, n41 UL MIMO PC1.5, n66, n70, 802.11b, 802.11g, 802.11n, 802.11ax, 802.11be.

Note(s):

- Average Antenna Input power = Average Frame power in order to account for the Operating Duty cycles for each respective Air Interface.
Worst Case MIF = the Highest MIF value for each respective RF Air Interface.
For operating modes where Average Antenna Input power plus MIF is below RF\_AIRL, they are compliant to RF\_AIRL requirements.
For operating modes where Average Antenna Input power plus MIF is above RF\_AIRL, they were evaluated to RF\_AIRL requirements. Refer to §11 for RF\_AIRL Evaluations.



**ANT 4**

Air-Interface	Frequency Range	Multiplex Scheme	Modulation	BW (MHz)	SCS (kHz)	Power Mode	Max Output Power (dBm)	Duty Cycle	Average Frame Power (dBm)	Worst Case MIF (dB)	RF <sub>AIPL</sub> (dBm)	RF <sub>AIL</sub> Limit (dBm)	HAC RF <sub>AIL</sub> Required
GSM1900	1850.2 - 1909.8	TDMA	GMSK	NA	NA	Max Power	29.0	12.5%	20.0	3.80	23.8	26	No
GSM1900	1850.2 - 1909.8	TDMA	GMSK	NA	NA	Max Power	28.0	25%	22.0	1.15	23.1	26	No
W-CDMA Band II	1850 - 1910	FDD	HSPA+	NA	NA	Max Power	22.9	100%	22.9	-20.39	2.5	26	No
W-CDMA Band IV	1710 - 1755	FDD	HSPA+	NA	NA	Max Power	22.9	100%	22.9	-20.39	2.5	26	No
LTE Band 2	1850 - 1910	FDD SC-FDMA	16-QAM	20	NA	Max Power	22.9	100%	22.9	-9.76	13.1	26	No
LTE Band 4	1710 - 1755	FDD SC-FDMA	16-QAM	20	NA	Max Power	25.2	100%	25.2	-9.76	15.4	26	No
LTE Band 7	2500 - 2570	FDD SC-FDMA	16-QAM	20	NA	Max Power	22.7	100%	22.7	-9.76	12.9	25	No
LTE Band 25	1850 - 1915	FDD SC-FDMA	16-QAM	20	NA	Max Power	22.9	100%	22.9	-9.76	13.1	26	No
LTE Band 30	2305 - 2315	FDD SC-FDMA	16-QAM	10	NA	Max Power	22.7	100%	22.7	-9.76	12.9	25	No
LTE Band 41 PC3	2496 - 2690	TDD SC-FDMA	16-QAM	20	NA	Max Power	25.7	63.3%	23.7	-1.44	22.3	25	No
LTE Band 41 PC2	2496 - 2690	TDD SC-FDMA	16-QAM	20	NA	Max Power	27.7	43.3%	24.1	-1.44	22.6	25	No
LTE Band 48 PC3	3550 - 3700	TDD SC-FDMA	16-QAM	20	NA	Max Power	25.2	63.3%	23.2	-1.44	21.8	25	No
LTE Band 66	2110 - 2200	FDD SC-FDMA	16-QAM	20	NA	Max Power	25.2	100%	25.2	-9.76	15.4	25	No
5G NR Band n2	1850 - 1910	FDD DFT-s-OFDM	QPSK	40	15	Max Power	22.9	100%	22.9	-15.07	7.8	26	No
5G NR Band n7	2500 - 2570	FDD DFT-s-OFDM	QPSK	50	15	Max Power	22.7	100%	22.7	-15.07	7.6	25	No
5G NR Band n25	1850 - 1915	FDD DFT-s-OFDM	QPSK	40	15	Max Power	22.9	100%	22.9	-15.07	7.8	26	No
5G NR Band n30	2305 - 2315	FDD DFT-s-OFDM	QPSK	10	15	Max Power	22.2	100%	22.2	-15.06	7.1	25	No
5G NR Band n41 PC3	2496 - 2690	TDD DFT-s-OFDM	QPSK	100	30	Max Power	25.7	100%	25.7	-16.69	9.0	25	No
5G NR Band n41 PC3	2496 - 2690	TDD CP-OFDM	QPSK	100	30	Max Power	24.2	100%	24.2	-14.38	9.8	25	No
5G NR Band n41 PC2	2496 - 2690	TDD DFT-s-OFDM	$\pi/2$ BPSK	100	30	Max Power	27.7	50%	24.7	-1.16	23.5	25	No
5G NR Band n41 PC2	2496 - 2690	TDD CP-OFDM	QPSK	100	30	Max Power	26.2	50%	23.2	-1.77	21.4	25	No
5G NR Band n41 UL MIMO PC1.5	2496 - 2690	TDD DFT-s-OFDM	$\pi/2$ BPSK	100	30	Max Power	31.2	25%	25.2	1.14	26.3	25	Yes
5G NR Band n41 UL MIMO PC1.5	2496 - 2690	TDD CP-OFDM	QPSK	100	30	Max Power	29.7	25%	23.7	0.47	24.1	25	No
5G NR Band n48 PC3	3550 - 3700	TDD DFT-s-OFDM	QPSK	100	30	Max Power	25.2	100%	25.2	-16.69	8.5	25	No
5G NR Band n48 PC3	3550 - 3700	TDD CP-OFDM	QPSK	100	30	Max Power	23.7	100%	23.7	-14.38	9.3	25	No
5G NR Band n48 UL MIMO PC3	3550 - 3700	TDD DFT-s-OFDM	QPSK	100	30	Max Power	24.51	100%	24.5	-16.69	7.8	25	No
5G NR Band n48 UL MIMO PC3	3550 - 3700	TDD CP-OFDM	QPSK	100	30	Max Power	23.01	100%	23.0	-14.38	8.6	25	No
5G NR Band n66	2110 - 2200	FDD DFT-s-OFDM	QPSK	40	15	Max Power	25.2	100%	25.2	-15.07	10.1	25	No
5G NR Band n70	1695 - 1710	FDD DFT-s-OFDM	QPSK	25	15	Max Power	25.2	100%	25.2	-15.06	10.1	26	No
5G NR Band n77 Block A PC3	3450 - 3550	TDD DFT-s-OFDM	QPSK	100	30	Max Power	26.0	100%	26.0	-16.69	9.3	25	No
5G NR Band n77 Block A PC3	3450 - 3550	TDD CP-OFDM	QPSK	100	30	Max Power	24.5	100%	24.5	-14.38	10.1	25	No
5G NR Band n77 Block A PC2	3450 - 3550	TDD DFT-s-OFDM	$\pi/2$ BPSK	100	30	Max Power	27.6	50%	24.6	-1.16	23.4	25	No
5G NR Band n77 Block A PC2	3450 - 3550	TDD CP-OFDM	QPSK	100	30	Max Power	26.1	50%	23.1	-1.77	21.3	25	No
5G NR Band n77 Block A UL MIMO PC1.5	3450 - 3550	TDD DFT-s-OFDM	$\pi/2$ BPSK	100	30	Max Power	31.2	25%	25.2	1.14	26.3	25	Yes
5G NR Band n77 Block A UL MIMO PC1.5	3450 - 3550	TDD CP-OFDM	QPSK	100	30	Max Power	29.7	25%	23.7	0.47	24.1	25	No
5G NR Band n77 Block C PC3	3700 - 3980	TDD DFT-s-OFDM	QPSK	100	30	Max Power	26.0	100%	26.0	-16.69	9.3	25	No
5G NR Band n77 Block C PC3	3700 - 3980	TDD CP-OFDM	QPSK	100	30	Max Power	24.5	100%	24.5	-14.38	10.1	25	No
5G NR Band n77 Block C PC2	3700 - 3980	TDD DFT-s-OFDM	$\pi/2$ BPSK	100	30	Max Power	27.6	50%	24.6	-1.16	23.4	25	No
5G NR Band n77 Block C PC2	3700 - 3980	TDD CP-OFDM	QPSK	100	30	Max Power	26.1	50%	23.1	-1.77	21.3	25	No
5G NR Band n77 Block C UL MIMO PC1.5	3700 - 3980	TDD DFT-s-OFDM	$\pi/2$ BPSK	100	30	Max Power	31.2	25%	25.2	1.14	26.3	25	Yes
5G NR Band n77 Block C UL MIMO PC1.5	3700 - 3980	TDD CP-OFDM	QPSK	100	30	Max Power	29.7	25%	23.7	0.47	24.1	25	No
802.11b	2402 - 2482	802.11b	DSSS	NA	NA	Max Power	22.0	100%	22.0	-2.02	20.0	25	No
802.11g	2402 - 2482	802.11g	DSSS/OFDM	NA	NA	Max Power	22.0	100%	22.0	0.12	22.1	25	No
802.11n	2402 - 2482	802.11n	MCS0	NA	NA	Max Power	22.0	100%	22.0	-5.59	16.4	25	No
802.11ax	2402 - 2482	802.11ax	MCS0	NA	NA	Max Power	22.0	100%	22.0	-5.58	16.4	25	No
802.11be	2402 - 2482	802.11be	MCS0	NA	NA	Max Power	22.0	100%	22.0	-5.58	16.4	25	No

**Note(s):**

- Average Antenna Input power = Average Frame power in order to account for the Operating Duty cycles for each respective Air Interface.
- Worst Case MIF = the Highest MIF value for each respective RF Air Interface.
- For operating modes where Average Antenna Input power plus MIF is below RF<sub>AIPL</sub>, they are compliant to RF<sub>AIPL</sub> requirements.
  - o For operating modes where Average Antenna Input power plus MIF is above RF<sub>AIPL</sub>, they were evaluated to RF<sub>AIL</sub> requirements. Refer to §11 for RF<sub>AIL</sub> Evaluations.

**ANT 5**

Air-Interface	Frequency Range	Multiplex Scheme	Modulation	BW (MHz)	SCS (kHz)	Power Mode	Max Output Power (dBm)	Duty Cycle	Average Frame Power (dBm)	Worst Case MIF (dB)	RF <sub>AIPL</sub> (dBm)	RF <sub>AIL</sub> Limit (dBm)	HAC RF <sub>AIL</sub> Required
802.11a/h	5150 - 5250	802.11a/h	OFDM	NA	NA	Max Power	20.0	100%	20.0	-3.15	16.9	25	No
802.11a	5150 - 5250	802.11a	OFDM	NA	NA	Max Power	20.0	100%	20.0	-9.82	10.2	25	No
802.11n	5150 - 5250	802.11n	MCS0	NA	NA	Max Power	21.0	100%	21.0	-5.59	15.4	25	No
802.11ac	5150 - 5250	802.11ac	MCS0	NA	NA	Max Power	21.0	100%	21.0	-5.56	15.4	25	No
802.11ax	5150 - 5250	802.11ax	MCS0	NA	NA	Max Power	21.0	100%	21.0	-5.58	15.4	25	No
802.11be	5150 - 5250	802.11be	MCS0	NA	NA	Max Power	21.0	100%	21.0	-5.58	15.4	25	No
802.11a/h	5250 - 5350	802.11a/h	OFDM	NA	NA	Max Power	20.0	100%	20.0	-3.15	16.9	25	No
802.11a	5250 - 5350	802.11a	OFDM	NA	NA	Max Power	20.0	100%	20.0	-9.82	10.2	25	No
802.11n	5250 - 5350	802.11n	MCS0	NA	NA	Max Power	21.0	100%	21.0	-5.59	15.4	25	No
802.11ac	5250 - 5350	802.11ac	MCS0	NA	NA	Max Power	21.0	100%	21.0	-5.56	15.4	25	No
802.11ax	5250 - 5350	802.11ax	MCS0	NA	NA	Max Power	21.0	100%	21.0	-5.58	15.4	25	No
802.11be	5250 - 5350	802.11be	MCS0	NA	NA	Max Power	21.0	100%	21.0	-5.58	15.4	25	No
802.11a/h	5470 - 5725	802.11a/h	OFDM	NA	NA	Max Power	20.0	100%	20.0	-3.15	16.9	25	No
802.11a	5470 - 5725	802.11a	OFDM	NA	NA	Max Power	20.0	100%	20.0	-9.82	10.2	25	No
802.11n	5470 - 5725	802.11n	MCS0	NA	NA	Max Power	21.0	100%	21.0	-5.59	15.4	25	No
802.11ac	5470 - 5725	802.11ac	MCS0	NA	NA	Max Power	21.0	100%	21.0	-5.56	15.4	25	No
802.11ax	5470 - 5725	802.11ax	MCS0	NA	NA	Max Power	21.0	100%	21.0	-5.58	15.4	25	No
802.11be	5470 - 5725	802.11be	MCS0	NA	NA	Max Power	21.0	100%	21.0	-5.58	15.4	25	No
802.11a/h	5725 - 5825	802.11a/h	OFDM	NA	NA	Max Power	21.0	100%	21.0	-3.15	17.9	25	No
802.11a	5725 - 5825	802.11a	OFDM	NA	NA	Max Power	21.0	100%	21.0	-9.82	11.2	25	No
802.11n	5725 - 5825	802.11n	MCS0	NA	NA	Max Power	21.0	100%	21.0	-5.59	15.4	25	No
802.11ac	5725 - 5825	802.11ac	MCS0	NA	NA	Max Power	21.0	100%	21.0	-5.56	15.4	25	No
802.11ax	5725 - 5825	802.11ax	MCS0	NA	NA	Max Power	21.0	100%	21.0	-5.58	15.4	25	No
802.11be	5725 - 5825	802.11be	MCS0	NA	NA	Max Power	21.0	100%	21.0	-5.58	15.4	25	No
802.11a/h	5825 - 6000	802.11a/h	OFDM	NA	NA	Max Power	20.5	100%	20.5	-3.15	17.4	25	No
802.11a	5825 - 6000	802.11a	OFDM	NA	NA	Max Power	20.5	100%	20.5	-9.82	10.7	25	No
802.11ax	5825 - 6000	802.11ax	MCS0	NA	NA	Max Power	20.5	100%	20.5	-5.58	14.9	25	No
802.11be	5825 - 6000	802.11be	MCS0	NA	NA	Max Power	20.5	100%	20.5	-5.58	14.9	25	No

**Note(s):**

- Average Antenna Input power = Average Frame power in order to account for the Operating Duty cycles for each respective Air Interface.
- Worst Case MIF = the Highest MIF value for each respective RF Air Interface.
- For all operating modes, Average Antenna Input power plus MIF is below RF<sub>AIPL</sub> therefore is compliant to RF<sub>AIPL</sub> requirements.

**ANT 6**

Air-Interface	Frequency Range	Multiplex Scheme	Modulation	BW (MHz)	SCS (kHz)	Power Mode	Max Output Power (dBm)	Duty Cycle	Average Frame Power (dBm)	Worst Case MIF (dB)	RF <sub>AIRL</sub> (dBm)	RF <sub>AIRL</sub> Limit (dBm)	HAC RF <sub>AIL</sub> Required
802.11a/h	5150 - 5250	802.11a/h	OFDM	NA	NA	Max Power	20.0	100%	20.0	-3.15	16.9	25	No
802.11a	5150 - 5250	802.11a	OFDM	NA	NA	Max Power	20.0	100%	20.0	-9.82	10.2	25	No
802.11n	5150 - 5250	802.11n	MCS0	NA	NA	Max Power	21.0	100%	21.0	-5.59	15.4	25	No
802.11ac	5150 - 5250	802.11ac	MCS0	NA	NA	Max Power	21.0	100%	21.0	-5.56	15.4	25	No
802.11ax	5150 - 5250	802.11ax	MCS0	NA	NA	Max Power	21.0	100%	21.0	-5.58	15.4	25	No
802.11be	5150 - 5250	802.11be	MCS0	NA	NA	Max Power	21.0	100%	21.0	-5.58	15.4	25	No
802.11a/h	5250 - 5350	802.11a/h	OFDM	NA	NA	Max Power	20.0	100%	20.0	-3.15	16.9	25	No
802.11a	5250 - 5350	802.11a	OFDM	NA	NA	Max Power	20.0	100%	20.0	-9.82	10.2	25	No
802.11n	5250 - 5350	802.11n	MCS0	NA	NA	Max Power	21.0	100%	21.0	-5.59	15.4	25	No
802.11ac	5250 - 5350	802.11ac	MCS0	NA	NA	Max Power	21.0	100%	21.0	-5.56	15.4	25	No
802.11ax	5250 - 5350	802.11ax	MCS0	NA	NA	Max Power	21.0	100%	21.0	-5.58	15.4	25	No
802.11be	5250 - 5350	802.11be	MCS0	NA	NA	Max Power	21.0	100%	21.0	-5.58	15.4	25	No
802.11a/h	5470 - 5725	802.11a/h	OFDM	NA	NA	Max Power	20.0	100%	20.0	-3.15	16.9	25	No
802.11a	5470 - 5725	802.11a	OFDM	NA	NA	Max Power	20.0	100%	20.0	-9.82	10.2	25	No
802.11n	5470 - 5725	802.11n	MCS0	NA	NA	Max Power	21.0	100%	21.0	-5.59	15.4	25	No
802.11ac	5470 - 5725	802.11ac	MCS0	NA	NA	Max Power	21.0	100%	21.0	-5.56	15.4	25	No
802.11ax	5470 - 5725	802.11ax	MCS0	NA	NA	Max Power	21.0	100%	21.0	-5.58	15.4	25	No
802.11be	5470 - 5725	802.11be	MCS0	NA	NA	Max Power	21.0	100%	21.0	-5.58	15.4	25	No
802.11a/h	5725 - 5825	802.11a/h	OFDM	NA	NA	Max Power	21.0	100%	21.0	-3.15	17.9	25	No
802.11a	5725 - 5825	802.11a	OFDM	NA	NA	Max Power	21.0	100%	21.0	-9.82	11.2	25	No
802.11n	5725 - 5825	802.11n	MCS0	NA	NA	Max Power	21.0	100%	21.0	-5.59	15.4	25	No
802.11ac	5725 - 5825	802.11ac	MCS0	NA	NA	Max Power	21.0	100%	21.0	-5.56	15.4	25	No
802.11ax	5725 - 5825	802.11ax	MCS0	NA	NA	Max Power	21.0	100%	21.0	-5.58	15.4	25	No
802.11be	5725 - 5825	802.11be	MCS0	NA	NA	Max Power	21.0	100%	21.0	-5.58	15.4	25	No
802.11a/h	5925 - 6000	802.11a/h	OFDM	NA	NA	Max Power	20.5	100%	20.5	-3.15	17.4	25	No
802.11a	5925 - 6000	802.11a	OFDM	NA	NA	Max Power	20.5	100%	20.5	-9.82	10.7	25	No
802.11ax	5925 - 6000	802.11ax	MCS0	NA	NA	Max Power	20.5	100%	20.5	-5.58	14.9	25	No
802.11be	5925 - 6000	802.11be	MCS0	NA	NA	Max Power	20.5	100%	20.5	-5.58	14.9	25	No

**Note(s):**

- Average Antenna Input power = Average Frame power in order to account for the Operating Duty cycles for each respective Air Interface.
- Worst Case MIF = the Highest MIF value for each respective RF Air Interface.
- For all operating modes, Average Antenna Input power plus MIF is below RF<sub>AIRL</sub> therefore is compliant to RF<sub>AIRL</sub> requirements.

**ANT 7**

Air-Interface	Frequency Range	Multiplex Scheme	Modulation	BW (MHz)	SCS (kHz)	Power Mode	Max Output Power (dBm)	Duty Cycle	Average Frame Power (dBm)	Worst Case MIF (dB)	RF <sub>AIRL</sub> (dBm)	RF <sub>AIRL</sub> Limit (dBm)	HAC RF <sub>AIL</sub> Required
LTE Band 48 PC3	3550 - 3700	TDD SC-FDMA	16-QAM	20	NA	Max Power	25.8	63.3%	23.8	-1.44	22.4	25	No
5G NR Band n48 PC3	3550 - 3700	TDD DFT-s-OFDM	QPSK	100	30	Max Power	25.8	100%	25.8	-16.69	9.1	25	No
5G NR Band n48 PC3	3550 - 3700	TDD CP-OFDM	QPSK	100	30	Max Power	24.3	100%	24.3	-14.38	9.9	25	No
5G NR Band n48 UL MIMO PC3	3550 - 3700	TDD DFT-s-OFDM	QPSK	100	30	Max Power	24.51	100%	24.5	-16.69	7.8	25	No
5G NR Band n48 UL MIMO PC3	3550 - 3700	TDD CP-OFDM	QPSK	100	30	Max Power	23.01	100%	23.0	-14.38	8.6	25	No
5G NR Band n77 Block A PC3	3450 - 3550	TDD DFT-s-OFDM	QPSK	100	30	Max Power	26.0	100%	26.0	-16.69	9.3	25	No
5G NR Band n77 Block A PC3	3450 - 3550	TDD CP-OFDM	QPSK	100	30	Max Power	24.5	100%	24.5	-14.38	10.1	25	No
5G NR Band n77 Block A PC2	3450 - 3550	TDD DFT-s-OFDM	π/2 BPSK	100	30	Max Power	28.7	50%	25.7	-1.16	24.5	25	No
5G NR Band n77 Block A PC2	3450 - 3550	TDD CP-OFDM	QPSK	100	30	Max Power	27.2	50%	24.2	-1.77	22.4	25	No
5G NR Band n77 Block A UL MIMO PC1.5	3450 - 3550	TDD DFT-s-OFDM	π/2 BPSK	100	30	Max Power	31.2	25%	25.2	1.14	26.3	25	Yes
5G NR Band n77 Block A UL MIMO PC1.5	3450 - 3550	TDD CP-OFDM	QPSK	100	30	Max Power	29.7	25%	23.7	0.47	24.1	25	No
5G NR Band n77 Block C PC3	3700 - 3980	TDD DFT-s-OFDM	QPSK	100	30	Max Power	26.0	100%	26.0	-16.69	9.3	25	No
5G NR Band n77 Block C PC3	3700 - 3980	TDD CP-OFDM	QPSK	100	30	Max Power	24.5	100%	24.5	-14.38	10.1	25	No
5G NR Band n77 Block C PC2	3700 - 3980	TDD DFT-s-OFDM	π/2 BPSK	100	30	Max Power	28.7	50%	25.7	-1.16	24.5	25	No
5G NR Band n77 Block C PC2	3700 - 3980	TDD CP-OFDM	QPSK	100	30	Max Power	27.2	50%	24.2	-1.77	22.4	25	No
5G NR Band n77 Block C UL MIMO PC1.5	3700 - 3980	TDD DFT-s-OFDM	π/2 BPSK	100	30	Max Power	31.2	25%	25.2	1.14	26.3	25	Yes
5G NR Band n77 Block C UL MIMO PC1.5	3700 - 3980	TDD CP-OFDM	QPSK	100	30	Max Power	29.7	25%	23.7	0.47	24.1	25	No

**Note(s):**

- Average Antenna Input power = Average Frame power in order to account for the Operating Duty cycles for each respective Air Interface.
- Worst Case MIF = the Highest MIF value for each respective RF Air Interface.
- For operating modes where Average Antenna Input power plus MIF is below RF<sub>AIRL</sub>, they are compliant to RF<sub>AIRL</sub> requirements.
  - For operating modes where Average Antenna Input power plus MIF is above RF<sub>AIRL</sub>, they were evaluated to RF<sub>AIL</sub> requirements. Refer to §11 for RF<sub>AIL</sub> Evaluations.

**ANT 8**

Air-Interface	Frequency Range	Multiplex Scheme	Modulation	BW (MHz)	SCS (kHz)	Power Mode	Max Output Power (dBm)	Duty Cycle	Average Frame Power (dBm)	Worst Case MIF (dB)	RF <sub>AIRL</sub> (dBm)	RF <sub>AIRL</sub> Limit (dBm)	HAC RF <sub>AIL</sub> Required
LTE Band 48 PC3	3550 - 3700	TDD SC-FDMA	16-QAM	20	NA	Max Power	25.6	63.3%	23.6	-1.44	22.2	25	No
5G NR Band n48 PC3	3550 - 3700	TDD DFT-s-OFDM	QPSK	100	30	Max Power	25.6	100%	25.6	-16.69	8.9	25	No
5G NR Band n48 PC3	3550 - 3700	TDD CP-OFDM	QPSK	100	30	Max Power	24.1	100%	24.1	-14.38	9.7	25	No
5G NR Band n48 UL MIMO PC3	3550 - 3700	TDD DFT-s-OFDM	QPSK	100	30	Max Power	24.51	100%	24.5	-16.69	7.8	25	No
5G NR Band n48 UL MIMO PC3	3550 - 3700	TDD CP-OFDM	QPSK	100	30	Max Power	23.01	100%	23.0	-14.38	8.6	25	No
5G NR Band n77 Block A PC3	3450 - 3550	TDD DFT-s-OFDM	QPSK	100	30	Max Power	26.0	100%	26.0	-16.69	9.3	25	No
5G NR Band n77 Block A PC3	3450 - 3550	TDD CP-OFDM	QPSK	100	30	Max Power	24.5	100%	24.5	-14.38	10.1	25	No
5G NR Band n77 Block A PC2	3450 - 3550	TDD DFT-s-OFDM	π/2 BPSK	100	30	Max Power	28.2	50%	25.2	-1.16	24.0	25	No
5G NR Band n77 Block A PC2	3450 - 3550	TDD CP-OFDM	QPSK	100	30	Max Power	26.7	50%	23.7	-1.77	21.9	25	No
5G NR Band n77 Block A UL MIMO PC1.5	3450 - 3550	TDD DFT-s-OFDM	π/2 BPSK	100	30	Max Power	31.2	25%	25.2	1.14	26.3	25	Yes
5G NR Band n77 Block A UL MIMO PC1.5	3450 - 3550	TDD CP-OFDM	QPSK	100	30	Max Power	29.7	25%	23.7	0.47	24.1	25	No
5G NR Band n77 Block C PC3	3700 - 3980	TDD DFT-s-OFDM	QPSK	100	30	Max Power	26.0	100%	26.0	-16.69	9.3	25	No
5G NR Band n77 Block C PC3	3700 - 3980	TDD CP-OFDM	QPSK	100	30	Max Power	24.5	100%	24.5	-14.38	10.1	25	No
5G NR Band n77 Block C PC2	3700 - 3980	TDD DFT-s-OFDM	π/2 BPSK	100	30	Max Power	28.2	50%	25.2	-1.16	24.0	25	No
5G NR Band n77 Block C PC2	3700 - 3980	TDD CP-OFDM	QPSK	100	30	Max Power	26.7	50%	23.7	-1.77	21.9	25	No
5G NR Band n77 Block C UL MIMO PC1.5	3700 - 3980	TDD DFT-s-OFDM	π/2 BPSK	100	30	Max Power	31.2	25%	25.2	1.14	26.3	25	Yes
5G NR Band n77 Block C UL MIMO PC1.5	3700 - 3980	TDD CP-OFDM	QPSK	100	30	Max Power	29.7	25%	23.7	0.47	24.1	25	No

**Note(s):**

- Average Antenna Input power = Average Frame power in order to account for the Operating Duty cycles for each respective Air Interface.
- Worst Case MIF = the Highest MIF value for each respective RF Air Interface.
- For operating modes where Average Antenna Input power plus MIF is below RF<sub>AIRL</sub>, they are compliant to RF<sub>AIRL</sub> requirements.
  - For operating modes where Average Antenna Input power plus MIF is above RF<sub>AIRL</sub>, they were evaluated to RF<sub>AIL</sub> requirements. Refer to §11 for RF<sub>AIL</sub> Evaluations.

**ANT 9**

Air-Interface	Frequency Range	Multiplex Scheme	Modulation	BW (MHz)	SCS (kHz)	Power Mode	Max Output Power (dBm)	Duty Cycle	Average Frame Power (dBm)	Worst Case MIF (dB)	RF <sub>AIPL</sub> (dBm)	RF <sub>AIPL</sub> Limit (dBm)	HAC RF <sub>AIL</sub> Required
LTE Band 48 PC3	3550 - 3700	TDD SC-FDMA	16-QAM	20	NA	Max Power	26.0	63.3%	24.0	-1.44	22.6	25	No
5G NR Band n48 PC3	3550 - 3700	TDD DFT-s-OFDM	QPSK	100	30	Max Power	26.0	100%	26.0	-16.69	9.3	25	No
5G NR Band n48 PC3	3550 - 3700	TDD CP-OFDM	QPSK	100	30	Max Power	24.5	100%	24.5	-14.38	10.1	25	No
5G NR Band n48 UL MIMO PC3	3550 - 3700	TDD DFT-s-OFDM	QPSK	100	30	Max Power	24.51	100%	24.5	-16.69	7.8	25	No
5G NR Band n48 UL MIMO PC3	3550 - 3700	TDD CP-OFDM	QPSK	100	30	Max Power	23.01	100%	23.0	-14.38	8.6	25	No
5G NR Band n77 Block A PC3	3450 - 3550	TDD DFT-s-OFDM	QPSK	100	30	Max Power	26.0	100%	26.0	-16.69	9.3	25	No
5G NR Band n77 Block A PC3	3450 - 3550	TDD CP-OFDM	QPSK	100	30	Max Power	24.5	100%	24.5	-14.38	10.1	25	No
5G NR Band n77 Block A PC2	3450 - 3550	TDD DFT-s-OFDM	$\pi/2$ BPSK	100	30	Max Power	28.7	50%	25.7	-1.16	24.5	25	No
5G NR Band n77 Block A PC2	3450 - 3550	TDD CP-OFDM	QPSK	100	30	Max Power	27.2	50%	24.2	-1.77	22.4	25	No
5G NR Band n77 Block A UL MIMO PC1.5	3450 - 3550	TDD DFT-s-OFDM	$\pi/2$ BPSK	100	30	Max Power	31.2	25%	25.2	1.14	26.3	25	Yes
5G NR Band n77 Block A UL MIMO PC1.5	3450 - 3550	TDD CP-OFDM	QPSK	100	30	Max Power	29.7	25%	23.7	0.47	24.1	25	No
5G NR Band n77 Block C PC3	3700 - 3980	TDD DFT-s-OFDM	QPSK	100	30	Max Power	26.0	100%	26.0	-16.69	9.3	25	No
5G NR Band n77 Block C PC3	3700 - 3980	TDD CP-OFDM	QPSK	100	30	Max Power	24.5	100%	24.5	-14.38	10.1	25	No
5G NR Band n77 Block C PC2	3700 - 3980	TDD DFT-s-OFDM	$\pi/2$ BPSK	100	30	Max Power	28.7	50%	25.7	-1.16	24.5	25	No
5G NR Band n77 Block C PC2	3700 - 3980	TDD CP-OFDM	QPSK	100	30	Max Power	27.2	50%	24.2	-1.77	22.4	25	No
5G NR Band n77 Block C UL MIMO PC1.5	3700 - 3980	TDD DFT-s-OFDM	$\pi/2$ BPSK	100	30	Max Power	31.2	25%	25.2	1.14	26.3	25	Yes
5G NR Band n77 Block C UL MIMO PC1.5	3700 - 3980	TDD CP-OFDM	QPSK	100	30	Max Power	29.7	25%	23.7	0.47	24.1	25	No

**Note(s):**

- Average Antenna Input power = Average Frame power in order to account for the Operating Duty cycles for each respective Air Interface.
- Worst Case MIF = the Highest MIF value for each respective RF Air Interface.
- For operating modes where Average Antenna Input power plus MIF is below RF<sub>AIPL</sub>, they are compliant to RF<sub>AIPL</sub> requirements.
  - For operating modes where Average Antenna Input power plus MIF is above RF<sub>AIPL</sub>, they were evaluated to RF<sub>AIL</sub> requirements. Refer to §11 for RF<sub>AIL</sub> Evaluations.

## 11. Evaluation for RF Audio Interference Level (RF<sub>AIL</sub>)

### 11.1. RF Audio Interference Level (RF<sub>AIL</sub>) Test Procedure

The following is a summary of the test procedure, taken from §4.5.3 of C63.19-2019:

- a. Confirm proper operation of the field probe, probe measurement system, spectral and temporal weighting filters, and the positioning system.
- b. Position the WD in its intended test position. A gauge block, depicted in A.1.2, can simplify this positioning.
- c. Set the WD to transmit a fixed and repeatable combination of signal power and modulation characteristic that is representative of the worst case (highest interference potential) encountered in normal use. Transiently occurring start-up, changeover, or termination conditions, or other operation likely to occur less than 1% of the time during normal operation, may be excluded from consideration.<sup>2</sup>
- d. The measurement area shall be centered on the acoustic output or the T-Coil mode measurement reference point, as appropriate. Locate the field probe at the initial test position in the 50 mm by 50 mm measurement area, which is contained in the measurement plane, described in 4.5.2 and illustrated in Figure A.1. If the field alignment method is used, align the probe for maximum field reception.
- e. Record the reading at the output of the measurement system.
- f. Scan the entire 50 mm by 50 mm measurement area in equally spaced step sizes and record the reading at each measurement point. The step size shall meet the specification for step size in 4.5.3.
- g. Calculate the average of the measurements taken in Step f).<sup>3</sup>
- h. Convert the average value found in Step g) to RF audio interference level, in volts per meter, by taking the square root of the reading and then dividing it by the measurement system transfer function, as established in 4.5.3.2.1 pre-test procedure. Convert the result to dB(V/m) by taking the base-10 logarithm and multiplying it by 20. Expressed as a formula:

$$RF \text{ audio interference level in dB}(V/m) = 20 \times \log \left( \frac{R_{ave}^{1/2}}{TF} \right)$$

where  $R_{ave}$  is the average reading

- i. Compare this RF audio interference level to the limits in Table 4.3 below and record the result.
  - a. Device is compliant if the average near-field emissions over the measurement area is at or below the stated RF<sub>AIL</sub> (Table 4.3)

**Table 4.3 - Wireless device RF audio interference level**

Frequency Range (MHz)	RF <sub>AIL</sub> [dB(V/m)]
≤ 960	39
960 – 2000	36
> 2000	35

#### **Indirect Measurement Method**

The measurement procedure using a probe and instrumentation chain with a response of <10 kHz (see 4.5.1) is identical to the direct measurement method of 4.5.3.2.2: however, because of the bandwidth limitations, it cannot include the direct use of the spectral and temporal weighting functions. The output of such measurement systems must be readings of steady state rms field strength in dB(V/m).

Replacing Step h) of 4.5.3.2.2: The RF audio interference level in dB(V/m) is obtained by adding the Modulation Interference Factor (in decibels) to the average steady state rms field strength reading over the measurement area, in dB(V/m), from Step g). Use this result to determine the WD's compliance per §4.7.

<sup>2</sup> Normally the amount of time a display remains on is a customer defined option. When this is true the display should not be illuminated during the test.

<sup>3</sup> Probe anisotropy may add significantly to the measurement uncertainty. This factor may be minimized by first moving the probe to the location of maximum measurement and then rotating the probe to align it for the maximum reading at that position. This rotation around the axis or shaft of the probe is recommended in order to minimize uncertainty due to anisotropy in the probe.

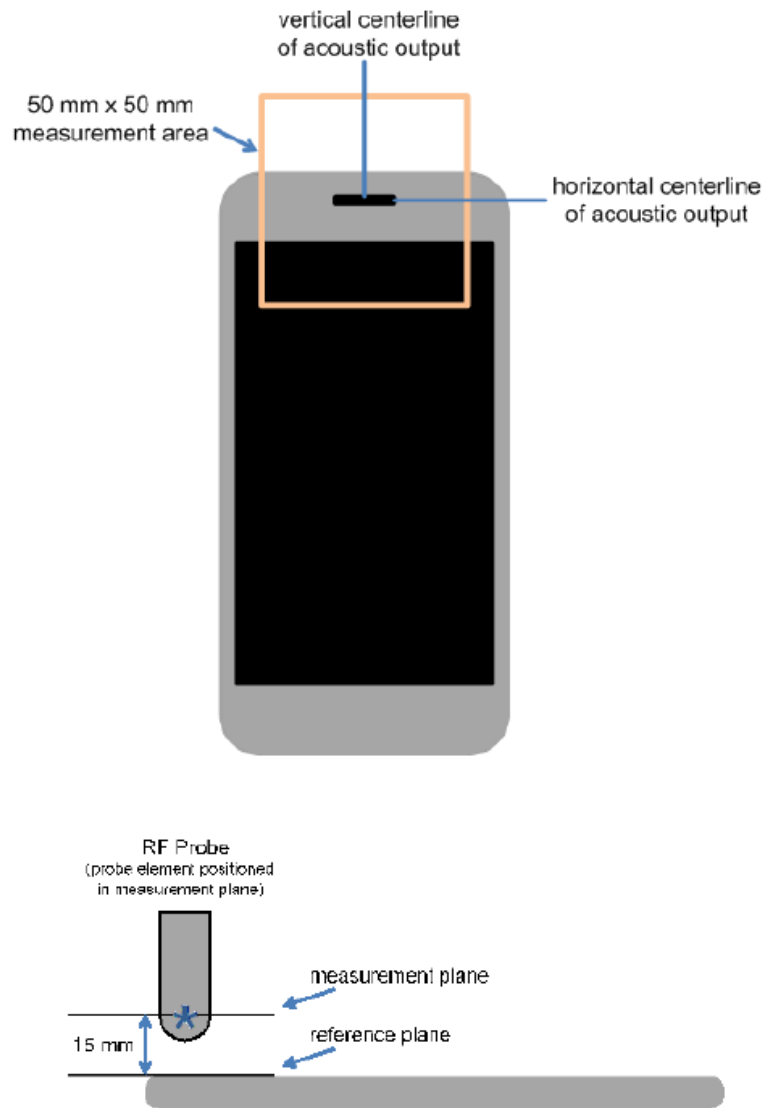
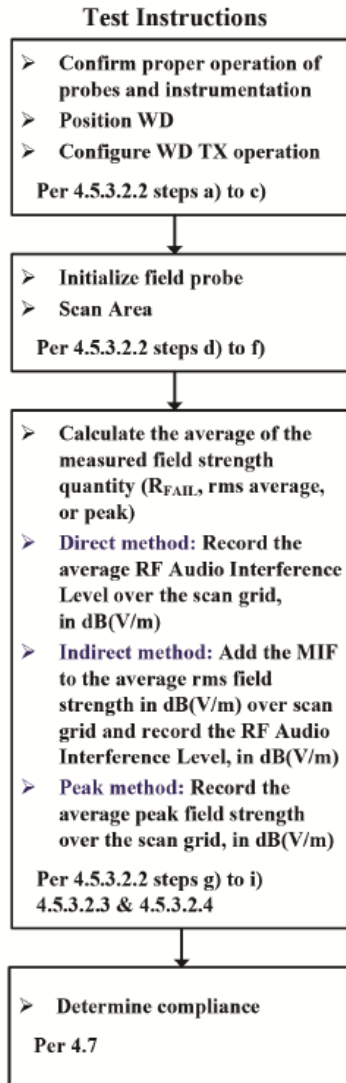

Figure 1 - WD reference and plane for RF emission measurements

Test flowchart Per ANSI-63.19-2019



## 11.2. RF Audio Interference Level (RF<sub>AIL</sub>) Measured Results

MIF values were not tested by a probe or as specified in the standards but are based on analysis provided by SPEAG for the following User Identifiers and air interfaces. The data included in this report are for the worst case operating modes. Refer to §8, Appendix D, G and H for the MIF values that represent the worst case operating modes.

For all air interfaces, the maximum held-to-head output power was used for the RF<sub>AIL</sub> evaluation. The maximum held-to-head output power is Mode A for WWAN operating modes and Power State 1 Mode A for WLAN operating modes.

### Measure Results

Antenna	Power Mode	Air-Interface	Ch. No.	Freq. (MHz)	RF <sub>AIL</sub> (dB V/m)	RF <sub>AIL</sub> Limit (dBm)	Result	Margin	Plot No.
ANT 1	Mode A	GSM1900 GPRS 1 Slot	512	1850.2	24.64	36	Pass	11.36	1
			661	1880.0	23.73	36	Pass	12.27	2
			810	1909.8	23.22	36	Pass	12.78	3
ANT 1	Mode A	GSM1900 GPRS 2 Slots	512	1850.2	24.26	36	Pass	11.74	4
			661	1880.0	23.33	36	Pass	12.67	5
			810	1909.8	22.40	36	Pass	13.60	6
ANT 1	Mode A	5G NR TDD n41 PC1.5 UL MIMO DFT-s-OFDM 50 MHz BW 50% RB, Mid offset	518598	2592.99	19.4	35	Pass	15.60	7
ANT 2	Mode A	5G NR TDD n41 PC1.5 UL MIMO DFT-s-OFDM 50 MHz BW 50% RB, Mid offset	518598	2592.99	<b>27.85</b>	35	Pass	7.15	8
ANT 3	Mode A	GSM1900 GPRS 1 Slot	512	1850.2	25.47	36	Pass	10.53	9
			661	1880.0	27.02	36	Pass	8.98	10
			810	1909.8	25.23	36	Pass	10.77	11
ANT 3	Mode A	5G NR TDD n41 PC1.5 UL MIMO DFT-s-OFDM 50 MHz BW 50% RB, Mid offset	518598	2592.99	22.25	35	Pass	12.75	12
ANT 4	Mode A	5G NR TDD n41 PC1.5 UL MIMO DFT-s-OFDM 50 MHz BW 50% RB, Mid offset	518598	2592.99	23.76	35	Pass	11.24	13
ANT 4	Mode A	5G NR TDD n77 PC1.5 Block A UL MIMO DFT-s-OFDM 50 MHz BW 50% RB, Mid offset	633334	3500.01	17.85	35	Pass	17.15	14
ANT 4	Mode A	5G NR TDD n77 PC1.5 Block C UL MIMO DFT-s-OFDM 50MHz BW 50% RB, Mid offset	657534	3863.01	17.51	35	Pass	17.49	15
ANT 7	Mode A	5G NR TDD n77 PC1.5 Block A UL MIMO DFT-s-OFDM 50 MHz BW 50% RB, Mid offset	633334	3500.01	22.16	35	Pass	12.84	16
ANT 7	Mode A	5G NR TDD n77 PC1.5 Block C UL MIMO DFT-s-OFDM 50MHz BW 50% RB, Mid offset	657534	3863.01	22.99	35	Pass	12.01	17
ANT 8	Mode A	5G NR TDD n77 PC1.5 Block A UL MIMO DFT-s-OFDM 50 MHz BW 50% RB, Mid offset	633334	3500.01	21.15	35	Pass	13.85	18
ANT 8	Mode A	5G NR TDD n77 PC1.5 Block C UL MIMO DFT-s-OFDM 50MHz BW 50% RB, Mid offset	657534	3863.01	22.6	35	Pass	12.40	19
ANT 9	Mode A	5G NR TDD n77 PC1.5 Block A UL MIMO DFT-s-OFDM 50 MHz BW 50% RB, Mid offset	633334	3500.01	16.71	35	Pass	18.29	20
ANT 9	Mode A	5G NR TDD n77 PC1.5 Block C UL MIMO DFT-s-OFDM 50MHz BW 50% RB, Mid offset	657534	3863.01	14.01	35	Pass	20.99	21

#### Note(s):

Measured RF<sub>AIL</sub> results are below RF<sub>AIL</sub> limits, therefore is compliant to RF<sub>AIL</sub> requirements.

### 11.3. Worst Case RF<sub>AIL</sub> Test Plot

UL Verification Services Inc. SAR H

Date/Time: August 20, 2024 at 14:38

## Band n41 RF Interference Potential Test Report

### Hardware Setup

Probe | Calibration Date EF3DV3 - SN4028 | September 04, 2023  
 DAE | Calibration Date DAE4 Sn1546 | March 11, 2024  
 Software Version 1.2.0.1713

### Communication Systems

MIF 1.14  
 Channel | Frequency [MHz] 518598 | 2592.99  
 Communication Systems' Name 5G NR (DFT-s-OFDM, 50% RB, 50 MHz,  $\pi/2$  BPSK, 30 kHz)

### Grid Settings

Extent X [mm]	50.0	Step X [mm]	10.0
Extent Y [mm]	50.0	Step Y [mm]	10.0
Distance [mm]	15.0		

### Results

E <sub>max</sub> [dBV/m]	<b>31.19</b>	E <sub>avg 50x50 Max</sub> [dBV/m]	<b>26.71</b>
Drift [dB]	<b>-0.04</b>	RFail [dBV/m]	<b>27.85</b>

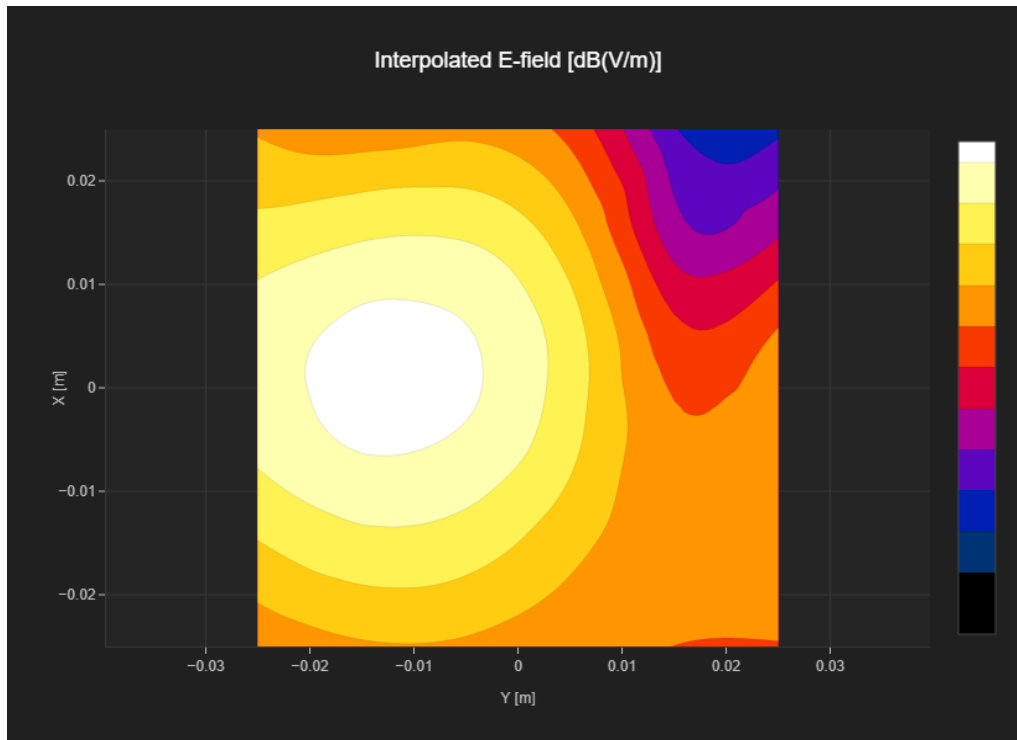



## **Appendixes**

Refer to separated files for the following appendixes

**Appendix A: RF-E Setup Photo**

**Appendix B: RF-E System Validation Plots**

**Appendix C: RF-E Test Plots**

**Appendix D: RF-E MIF Attestation Letter**

**Appendix E: RF-E Probe Certificates**

**Appendix F: RF-E Dipole Certificates**

**Appendix G: RF-E UID Specifications**

**Appendix H: RF-E MIF Measurements**

**END OF REPORT**