



HAC T-COIL SIGNAL TEST REPORT

**FCC 47 CFR § 20.19
ANSI C63.19-2019**

For
SMARTPHONE

**FCC ID: BCG-E8668A
Model Name: A3293**

**Report Number: 14982439-S2V1
Issue Date: 7/30/2024**

Prepared for
**APPLE INC.
1 APPLE PARK WAY
CUPERTINO, CA 95014-2084**

Prepared by
**UL VERIFICATION SERVICES INC.
47173 BENICIA STREET
FREMONT, CA 94538, U.S.A.
TEL: (510) 319-4000
FAX: (510) 661-0888**



CERT #0751.05

Revision History

Rev.	Date	Revisions	Revised By
V1	7/30/2024	Initial Issue	--

Table of Contents

- 1. Attestation of Test Results4**
- 2. Test Methodology5**
- 3. Facilities and Accreditation5**
- 4. Test Equipment and Uncertainty.....6**
 - 4.1. *Test Equipment*6
 - 4.1.1. *Base Station Simulator Software and Firmware*7
 - 4.2. *Measurement Uncertainty*8
- 5. Test Procedures for all Technologies.....9**
 - 5.1. *Test Procedure for T-Coil signal per ANSI C63.19-2019, §6*9
 - 5.2. *Reference Input Levels per ANSI C63.19-2019, §6*11
 - 5.3. *Over the Top (OTT)*12
- 6. Calibrations & Gain Measurements14**
 - 6.1. *Calibration of AM1DVx Probe*.....14
 - 6.1.1. *Calibration Setup*.....14
 - 6.1.2. *Sensor Angle Alignment*.....14
 - 6.1.3. *System Response Calibration*.....14
 - 6.2. *AMMI Audio Output Calibration*14
 - 6.3. *Codec / System Delay Measurements*15
 - 6.4. *Compute Gain Settings*15
 - 6.5. *Over the Top (OTT)*16
- 7. T-coil Measurement Criteria.....17**
 - 7.1. *Frequency Response*17
 - 7.2. *Coupling Mode Requirements*.....18
 - 7.3. *Desired ABM Signal and Undesired ABM Field Requirements*.....19
 - 7.3.1. *Non-2G GSM Operating modes*.....19
 - 7.3.2. *2G GSM Operating modes*.....19
- 8. Device Under Test.....20**
 - 8.1. *Air Interfaces and Operating Mode*20
- 9. Investigations (Antenna, Codec, & Air Interface)22**
 - 9.1. *CMRS*24
 - 9.1.1. *Antenna Investigation*.....24
 - 9.1.2. *Codec Investigation*.....25
 - 9.1.3. *Air Interface Investigation*.....27
 - 9.2. *OTT Application*.....29
 - 9.2.1. *Codec Investigation*.....29
- 10. HAC (T-coil) Test Results.....30**
 - 10.1. *Worst Case T-Coil Test Plot(s)*.....33
- Appendix.....35**
 - Appendix A: T-Coil Setup Photo*35
 - Appendix B: T-Coil Test Plots*35
 - Appendix C: T-Coil Probe Certificates*35

1. Attestation of Test Results

Applicant Name	APPLE, INC.
FCC ID	BCG-E8668A
Model Name	A3293
Applicable Standards	FCC 47 CFR § 20.19 ANSI C63.19-2019
Date Tested	7/25/2024 to 7/29/2024
Test Results	Pass

UL Verification Services Inc. assessed the above equipment in accordance with the requirements set forth in the above standards. The test results show that the equipment assessed can demonstrate compliance with the requirements as documented in this report.

This report contains data provided by the customer which can impact the validity of results. UL Verification Services Inc. is only responsible for the validity of results after the integration of the data provided by the customer.

The results documented in this report apply only to the tested sample, under the conditions and modes of operation as described herein. It is the manufacturer's responsibility to assure that additional production units of this model are manufactured with identical electrical and mechanical components. All samples assessed were in good operating condition throughout the entire test program. Measurement Uncertainties are published for informational purposes only and were not considered unless noted otherwise.

This document may not be altered or revised in any way unless done so by UL Verification Services Inc. and all revisions are noted in the revisions section. Any alteration of this document not conducted by UL Verification Services Inc. will constitute fraud and shall nullify the document. This report must not be used by the client to claim product certification, approval, or endorsement by A2LA, NIST, or any agency of the U.S. Government, or any agency of the U.S. government.

Approved & Released By:



Devin Chang
Senior Laboratory Engineer
UL Verification Services Inc.

Prepared By:



Coltyce Sanders
Staff Laboratory Engineer
UL Verification Services Inc.

2. Test Methodology

The tests documented in this report were performed in accordance with ANSI C63.19-2019 Methods of Measurement of Compatibility Between Wireless Communications Devices and Hearing Aids and FCC published procedure:

KDB 285076 D01 HAC Guidance v06r04
 KDB 285076 D02 T-Coil testing for CMRS IP v04
 KDB 285076 D03 HAC FAQ v01r06

In addition to the above, the following guidance was used:

TCB workshop updates:

- TCB Workshop October 2022; Publication Update & Administrative Notes (Publication Update: 285076 D01 & D04)
- TCB Workshop October 2022; Federal Communications Commission Hearing Aid Compatibility Updates
- TCB Workshop April 2023; Publication Update & Administrative Notes (Publications Since Oct Workshop: 285076 HAC Update)
- TCB Workshop October 2023; Publication Update & Administrative Notes (Publication Update: 285076 09/29/2023: HAC Guidance blanket)
- TCB Workshop April 2024; HAC Updates (Handset Configuration)

3. Facilities and Accreditation

The test sites and measurement facilities used to collect data are located at

47266 Benicia Street
SAR Lab 11

UL Verification Services Inc. is accredited by A2LA, Certificate Number 0751.05

The Test Lab Conformity Assessment Body Identifier (CABID)

Location	CABID	Company Number
47173 Benicia Street, Fremont, CA, 94538 UNITED STATES	US0104	2324A
47266 Benicia Street, Fremont, CA, 94538 UNITED STATES		

4. Test Equipment and Uncertainty

4.1. Test Equipment

The measuring equipment used to perform the tests documented in this report has been calibrated in accordance with the manufacturers' recommendations and is traceable to recognized national standards.

Lab Equipment

Name of Equipment	Manufacturer	Type/Model	Serial No.	Cal. Due Date
Magnetic Field Probe	SPEAG	AM1DV3	3083	1/8/2025
Data Acquisition Electronics	SPEAG	DAE4	1352	11/15/2024
AMMI	SPEAG	SE UMS 010 BB	1113	N/A
DAC	Sound Devices	USBPre 2	HB1420133009	N/A
DAC	Yellow tech	YT4211	22000115	N/A
Amplifier	KROHN-HITE	7500	926	N/A
Switch	TP-Link	TL-SG1024D	13688100415	N/A
Support Device	APPLE	iMAC	PT867513	N/A
Support Device	APPLE	MacBook Pro	HRP119301	N/A
Thermometer	TRACEABLE	6530CC	181073773	1/31/2025
Radio Communication Tester	R&S	CMW 500	125236-eS	2/19/2025
Radio Communication Tester	R&S	CMX 500	101156-bz	3/18/2025
Up/Down Converter	R&S	CMW-Z800A	100198-XW	02/28/2025

4.1.1. Base Station Simulator Software and Firmware

The following software/firmware was used to simulate the VoLTE, VoNR (5G NR) and VoWiFi server for CMRS testing using R&S CMW500 and CMX500 base station simulators.

Technology	Firmware	License Key	Software Name
VoLTE	V3.8.10 for LTE	KS500	LTE FDD R8 SIG BASIC
		KS550	LTE TDD R8 SIG BASIC
	V3.8.10 for Audio	KA100	IP APPL ENABLING IPv4
		KA150	IP APPL ENABLING IPv6
		KAA20	IP APPL IMS BASIC
		KM050	DATA APPL MEAS
		KS104	EVS SPEECH CODEC
VoNR - 5G NR (FR1)	V7.70.0.116 for 5G NR	CMX-KS600B	NR SIG BASIC FSET1
		CMX-KS600M	NR SIG MEDIUM FSET1
		CMX-KS600X	NR SIG XPERT FSET1
		CMX-KS601B	NR SIG BASIC FSET2
		CMX-KS601M	NR SIG MEDIUM FSET2
		CMX-KS601X	NR SIG XPERT FSET2
		CMX-KS610B	NR SIG BASIC FSET3
		CMX-KS610M	NR SIG MEDIUM FSET3
		CMX-KS610X	NR SIG XPERT FSET3
		CMX-KS611B	NR SIG BASIC FSET4
		CMX-KS611M	NR SIG MEDIUM FSET4
		CMX-KS611X	NR SIG XPERT FSET4
		CMX-KS612B-CMX-KS612B	NR SIG EXT. BASIC FSET5
		CMX-KS612M-CMX-KS612M	NR SIG EXT. MEDIUM FSET5
		CMX-KS612X-CMX-KS612X	NR SIG EXT. EXPERT FSET5
		CMX-KS617B-CMX-KS617B	NR SIG EXT. BASIC FSET6
		CMX-KS617M-CMX-KS617M	NR SIG EXT. MEDIUM FSET6
		CMX-KS617X-CMX-KS617X	NR SIG EXT. EXPERT FSET6
VoWiFi	V3.8.20 for WLAN	KS650	WLAN A/B/G SIG BASIC
		KS651	WLAN N SIG BASIC
		KS656	WLAN IEEE 802.11ac
		KS657	WLAN IEEE 802.11ax
	V3.8.10 for Audio	KA100	IP APPL ENABLING IPv4
		KA150	IP APPL ENABLING IPv6
		KAA20	IP APPL IMS BASIC
		KM050	DATA APPL MEAS
		KS104	EVS SPEECH CODEC

4.2. Measurement Uncertainty

Uncertainty of Audio Band Magnetic Measurements							
Error Description	Uncertainty Values (±%)	Probe Dist.	Div.	(c _i) ABMd	c _i ABMu	Std. Uncertainty	
						ABMd (±%)	ABMu (±%)
Probe Sensitivity							
Reference Level	3.0	N	1	1	1	3.0	3.0
AMCC Geometry	0.4	R	√3	1	1	0.2	0.2
AMCC Current	1.0	R	√3	1	1	0.6	0.6
Probe Positioning during Calibration	0.1	R	√3	1	1	0.1	0.1
Noise Contribution	0.7	R	√3	0.0143	1	0.0	0.4
Frequency Slope	5.9	R	√3	0.1	1.0	0.3	3.5
Probe System							
Repeatability / Drift	1.0	R	√3	1	1	0.6	0.6
Linearity / Dynamic Range	0.6	R	√3	1	1	0.4	0.4
Acoustic Noise	1.0	R	√3	0.1	1	0.1	0.6
Probe Angle	1.0	R	√3	1	1	0.6	0.6
Spectral Processing	0.9	R	√3	1	1	0.5	0.5
Integration Time	0.6	N	1	1	5	0.6	3.0
Field Disturbation	0.2	R	√3	1	1	0.1	0.1
Test Signal							
Reference Signal Spectral Response	0.6	R	√3	0	1	0.0	0.4
Positioning							
Probe Positioning	1.9	R	√3	1	1	1.1	1.1
Phantom Thickness	0.9	R	√3	1	1	0.5	0.5
DUT Positioning	1.9	R	√3	1	1	1.1	1.1
External Contributions							
RF Interference	0.0	R	√3	1	0.3	0.0	0.0
Test Signal Variation	2.0	R	√3	1	1	1.2	1.2
Combined Uncertainty							
Combined Std. Uncertainty (ABM field)						3.9	6.0
Expanded Std. Uncertainty (%)						7.8	11.9
Notes:							
1. N - Nomal							
2. R - Rectangular							
3. Div. - Divisor used to obtain standard uncertainty							
4. ABMd - Desired ABM Signal							
5. ABMu - Undesired ABM Field							

5. Test Procedures for all Technologies

5.1. Test Procedure for T-Coil signal per ANSI C63.19-2019, §6

This subclause describes the procedures used to measure the ABM (T-Coil) performance of the WD. Measurements shall be performed over a measurement area 50 mm square, in the measurement plane, as specified in Annex A.3. The measurement area shall be scanned with a uniform measurement point spacing of $2.0 \text{ mm} \pm 0.5 \text{ mm}$ in each X-Y axis of the plane, yielding 676 measurement points with approximately even spacing throughout the area.

Optionally, measurement point spacing may be increased to 4 mm, with interpolation employed to yield the required 676 equivalent measurement points distributed uniformly over the 50 mm square measurement area. Interpolated points shall be derived from the average of the linear representations of the field strengths of the nearest two or four equidistant measured points. The area of measurement is increased to a 52 mm square so that edge rows and columns of the required 50 mm square can be either measured or interpolated, with none extrapolated.

In addition to measuring the desired ABM signal levels, the weighted magnitude of the unintended signal shall also be determined. Weighting of the unintended and undesired ABM field shall be by the spectral and temporal weighting described in Annex D.4 through D.6.

In order to assure that the required signal quality is measured, the measurement of the intended signal and the measurement of the unintended signal shall be made at the same locations. Measurements shall not include undesired influence from the WD's RF field; therefore, use of a coaxial connection to a base station simulator or non-radiating load might be necessary. However, even then with a coaxial connection to a base station simulator or non-radiating load there could still be RF leakage from the WD, which could interfere with the desired measurement. Pre-measurement checks should be made to avoid this possibility. All measurements shall be done with the WD operating on battery power with an appropriate normal speech audio signal input level given in Table 6.1. If the device display can be turned off during a phone call, then that may be done during the measurement as well. If tested with the display in the off state this shall be documented in the test report.

Measurements shall be performed with the probe coil oriented in the transverse direction, as illustrated in Annex A.3, that is, aligned in the plane of the measurement area and perpendicular to the long dimension of the WD. A multi-stage sequence consists of first measuring the field strength of the desired T-Coil signal (desired ABM signal) that is useful to a hearing aid T-Coil at each specified measurement point. The undesired magnetic component (undesired ABM field) is then measured in the same transverse orientation at each of the same measurement points. At a single location only, taken at or near the highest desired ABM signal reading, the desired ABM signal frequency response shall be determined in a third measurement stage. The flowchart in Figure 6.3 illustrates this three-stage process.

To minimize the need to test every WD operating mode to the telecoil requirements of Clause 6, it is permissible to exclude some subset of supported configurations. For a given WD, every mode that supports voice communication shall be considered for telecoil testing. However, if it can be demonstrated that a certain configuration will not be the worst-case telecoil configuration, such configurations may be excluded from the full telecoil scans of 6.4.¹ For example, operating modes may be pre-screened by scanning for both desired ABM signal and undesired ABM field at a lower measurement point density than the final scans, thus saving considerable testing time by eliminating configurations that are excellent performers from more detailed testing for worst-case. In any case, the specific methods and criteria used to determine which configurations are excluded for a WD shall be explicitly stated and justified in the test report. To be considered for exclusion from telecoil testing, operating modes shall also be shown to pass the frequency response requirements of 6.6.3.

Many factors could affect telecoil test results. RF power level and amplitude modulation characteristics as well as the specific current paths within the WD associated with the RF output stage(s), the display, and processing circuitry could affect the undesired ABM field. Audio codec implementation and acoustic receiver characteristics could also affect the desired ABM signal). Therefore, any justifications for exclusions should be thorough documented. If an operating mode is under user control and instructions on how to place the WD in a less interfering condition is in the user instructions, those instructions may be followed in configuring the device for testing.

The following steps summarize the basic test flow for determining desired ABM signal and undesired ABM field. These steps assume that a sine wave or narrowband 1/3 octave signal can be used for the measurement of desired

¹ The allowance to not test all modes does not remove the requirement that all modes meet the requirements of this standard if a claim of compliance is to be made. What is allowed is a reduction of testing, where there is a good basis for believing that testing that is performed demonstrates the compliance of all possible operating modes.

ABM signal level. An alternative procedure, yielding equivalent results, using a broadband excitation is described in 6.5.

- a) A validation of the test setup and instrumentation shall be performed. This may be done using a TMFS or Helmholtz Coil. Measure the emissions and confirm that they are within tolerance of the expected values.
- b) Confirm that equipment that requires calibration has been calibrated, and that the noise level meets the requirements given in 6.3.2.
- c) Position the WD in the test setup and connect the WD RF connector to a base station simulator or a non-radiating load (if necessary to control RF interference in the measurement equipment) as shown in Figure 6.1 or Figure 6.2.
- d) The drive level to the WD is set such that the reference input level specified in Table 6.1 is input to the base station simulator (or manufacturer's test mode equivalent) in the 1 kHz, 1/3 octave band. This drive level shall be used for the T-Coil signal test (desired ABM signal) at $f = 1$ kHz. Either a sine wave at 1025 Hz, or a voice-like signal, band-limited to the 1 kHz 1/3 octave, as specified in 6.4.3, shall be used for the reference audio signal. If interference is found at 1025 Hz an alternative nearby reference audio signal frequency may be used.² The same drive level will be used for the desired ABM signal frequency response measurements at each 1/3 octave band center frequency. The WD volume control may be set at any level up to maximum, provided that a signal at any frequency at maximum modulation would not result in clipping or signal overload.
- e) At each measurement location over the measurement area and in the transverse orientation, measure and record the desired 1 kHz T-Coil magnetic signal (desired ABM signal) as described in Step c).
- f) At or near a location representing a maximum in the just-measured desired ABM signal, measure and record the desired T-Coil magnetic signals (desired ABM signal at f_i) as described in 6.4.5.2 in each individual ISO 266:1975 R10 standard 1/3 octave band. The desired audio band input frequency (f_i) shall be centered in each 1/3 octave band maintaining the same drive level as determined in Step c), and the reading taken for that band.³ Equivalent methods of determining the frequency response may also be employed, such as fast Fourier transform (FFT) analysis using noise excitation or input-output comparison using simulated speech. The full-band integrated or half-band integrated probe output, as described in D.9, may be used, as long as the appropriate calibration curve is applied to the measured result, so as to yield an accurate measurement of the field magnitude. (The resulting measurement shall be an accurate measurement in dB(A/m).) Compare the frequency response found to the requirements of 6.6.3.
- g) At the same locations measured in Step d), measure and record the undesired broadband audio magnetic signal (undesired ABM field) with no audio signal applied (or digital zero applied, if appropriate) using the specified spectral weighting, the half-band integrator followed by the temporal weighting.
- h) Calculate and record the location and number of the measurement points that satisfy both the minimum desired ABM signal level and the maximum undesired ABM field level specified in 6.6.2. Compare this to the requirements in 6.6.4 and record the result.
- i) Calculate and record the location and number of the measurement points that satisfy the maximum undesired ABM field level and distribution requirements specified in 6.6.4.

² The 1025 Hz frequency was selected rather than 1 kHz because a 1 kHz reference frequency could interfere with emission harmonics or test equipment fundamental frequencies.

³ See 6.4.5.2 and 6.4.5.4 for details.

Test Setup Diagram

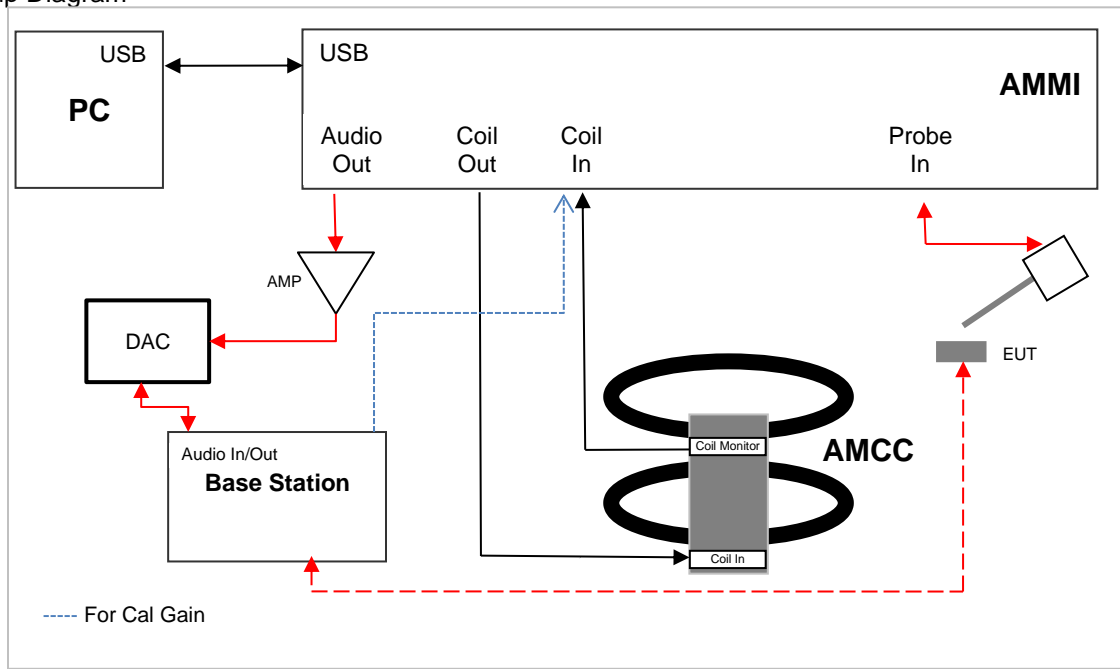

Note(s):
 For Audio OUT, an amplifier was added to amplify signal to meet DAC specifications.

5.2. Reference Input Levels per ANSI C63.19-2019, §6

The following reference input levels (Figure 6.1) that correlate to a normal speech input level shall be used for the standard transmission protocols.⁴

Table 6.1 - Normal speech input levels

Standard	Protocol	Input (dBm0)
TIA-2000	CDMA	-18
TIA/EIA-136	TDMA (50 Hz)	-18
J-STD-007	GSM (217 Hz)	-16
T1/T1P1/3GPP (See Note 1)	UMTS (WCDMA)	-16
iDEN [®]	TDMA (22 Hz and 11 Hz)	-18
VoIP ^a (See Note 2)	Voice over Internet Protocol	-16

NOTE 1 - For UMTS (Universal Mobile Telecommunications System), refer to 3GPP TS26.131 and TS26.132 (<http://www.3gpp.org>).
 NOTE 2 - VoIP is used in this table as a general term specifying a group of voice services that use -16 dBm0 as their normal acoustic level. The group includes a variety of voice services, including Voice-over-LTE (VoLTE), Voice-over-IP-multimedia-subsystem (VoIMS), Voice-over-Wi-Fi (VoWiFi) and similar services. For 3G, LTE, and WLAN terminals used for Commercial Mobile Radio Service (CMRS) based telephony, refer to 3GPP TS26.131 and TS26.132.

^a The manufacturer shall establish that -16 dBm0 is the normal acoustic level in order to place it in this category.

For protocols not listed in Table 6.1, use the normal speech input level per the relevant specifications for that air interface.

⁴ The intent of this subclause is to provide a nominal level speech input independent of air interface and measure the magnetic response in a normal use condition without requiring an acoustic reference. The nominal level speech signals in 6.4.3.2 will result in acoustic speech levels that are mutually consistent and also span a range including 94 dB SPL, as shown in the examples below. This is intended to allow the operator to set WD adjustable volume controls as needed to produce a sufficient desired magnetic level (desired ABM signal) based on intended usage. When measuring with the specified nominal speech input level of -16 dBm0 for GSM, a GSM phone shall not exceed a receive loudness rating (RLR) of -13 dB at maximum volume setting. However, at a nominal volume control setting with the same -16 dBm0 input, a GSM phone shall have an RLR of at least 2 dB ± 3 dB. An RLR of 2 dB ± 3 dB corresponds to a sound pressure level of 84 dB ± 3 dB SPL, assuming an earpiece frequency response that is flat over the frequency bands specified as per ITU-T Recommendation P.79. An RLR of -13 dB corresponds to a sound pressure level of 99 dB SPL, assuming an earpiece frequency response that is flat over the frequency bands specified as per ITU-T Recommendation P.79. When measuring with the specified nominal speech input level of -18 dBm0 for CDMA, a CDMA phone with volume control set to the midpoint should provide an RLR of 2 dB ± 5 dB. The CTIA (Rev. 3.21, 2003) CDMA test plan (V1.2) does not specifically place an upper limit on RLR. References: ITU-T Recommendation P.79. Calculation of loudness ratings for telephone handsets. Cellular Telecommunications Industry Association Performance Evaluation Standard for 800 MHz AMPS and Cellular/PCS CDMA Dual Mode Wireless Subscriber Stations.

5.3. Over the Top (OTT)

This device supports VoIP via a preinstalled application that uses the FaceTime service, using ACC-ELD as its only codec (refer to §8.1 for air interface details and §9.2.2 for codec bit rates). VoIP capabilities require HAC assessment when voice calls are supported over the cellular data connection via pre-installed VoIP applications.

The equipment is set up as shown below with a support device used to originate the call using the IP transport. The support device⁵ connects to the cloud-based FaceTime service via a Wi-Fi access point and router, or an RJ45 Ethernet connection. The DUT connects to the VoIP service via a cellular/unlicensed air interface to the call box and an Ethernet connection from call box to Internet. The various codec bit rate and air interface configurations are evaluated to determine the worst-case configuration (refer to §9.2).

Test Setup configuration for OTT calls:

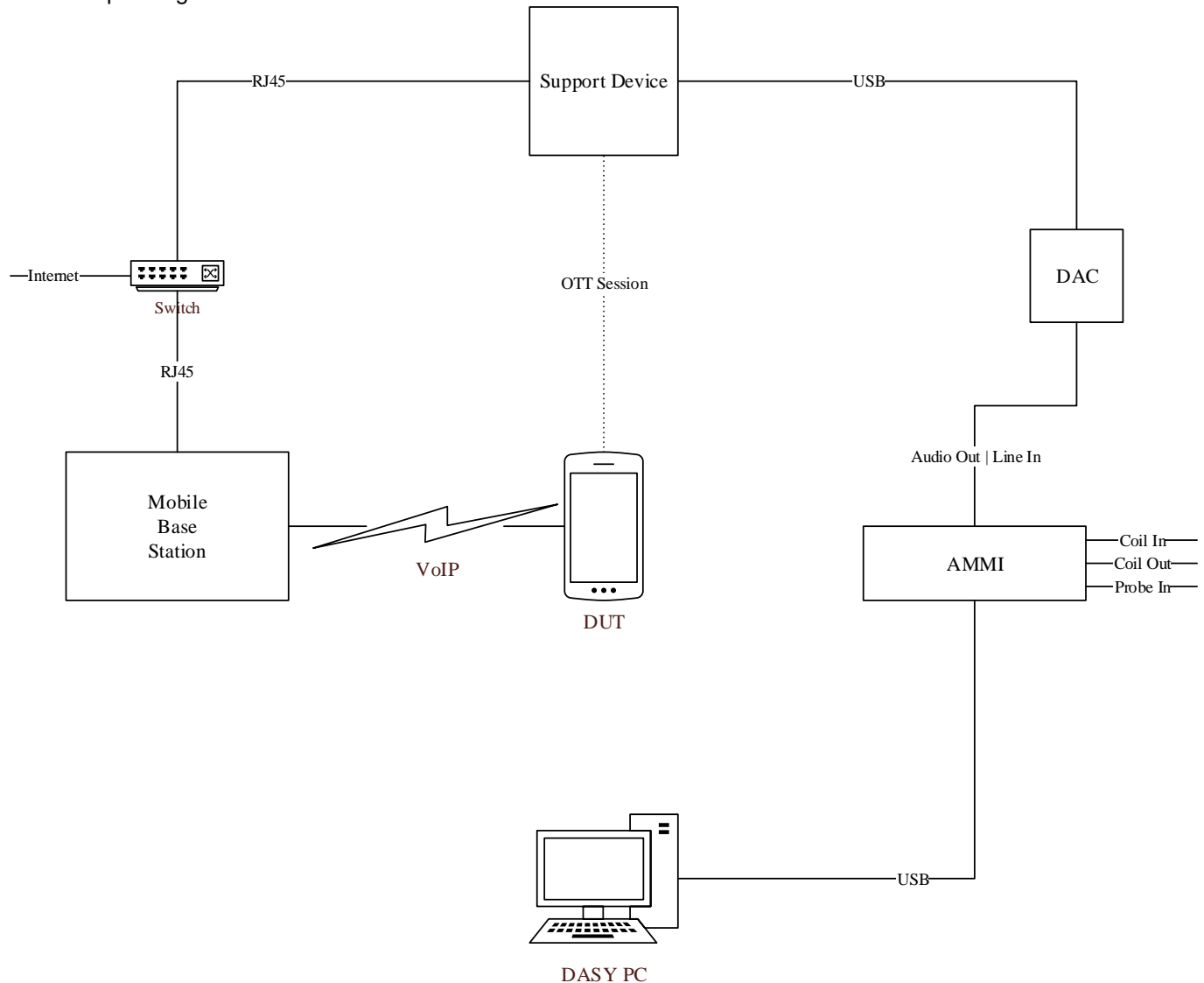

For the OTT call, the calibrated audio card within the CMW500 cannot be used so the AMMI is connected to an external Digital-Analog Converter (DAC) and the DAC is connected to the Support Device via USB. The test signal is sent from the DASY PC to the AMMI, from the AMMI to the DAC, from the DAC to the Support Device, and, via the VoIP call, to the DUT.

⁵ The support device is a Google Mobile Phone.

As this test set up uses an external DAC between the AMMI's audio output and support device, the appropriate gain factor for the OTT call needs to be determined. This is done by connecting the DAC between the AMMI Audio output and Coil input as shown below.

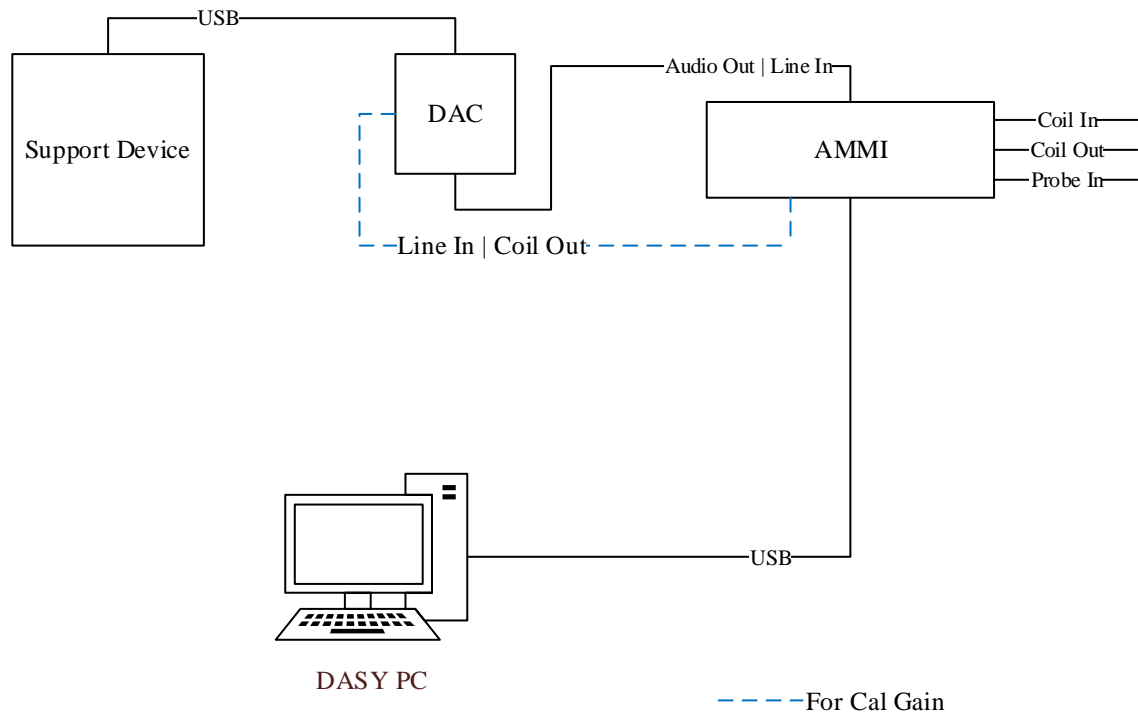

Once the proper cable connections are established, the procedures outlined in §6 are followed to calculate the appropriate Gain and codec / system delays for OTT measurements. Please refer to §6.5 for computed OTT gain settings and the test data tables in §9 & 10 for all Codec / system delay measurements performed during OTT testing.

6. Calibrations & Gain Measurements

Calibrations and Gain measurements are performed using guidance from SPEAG's *DASY6/8 Module HAC System Handbook §7.3*.

6.1. Calibration of AM1DVx Probe

For correct measurement of the audio-band magnetic field, the AM1DVx probe must first be calibrated. The calibration is performed in the Helmholtz Audio Magnetic Calibration Coil (AMCC).

6.1.1. Calibration Setup

During the calibration procedure, the system is set as described below:

- the AMMI is powered on and connected to the DASY6/8 PC via USB.
- the AMMI COIL OUT port is connected to the AMCC COIL IN.
- the AMMI COIL IN port is connected to the AMCC COIL MONITOR.
- the AM1DVx probe is mounted on the robot.

6.1.2. Sensor Angle Alignment

The sensor angle relative to the robot arm depends on several factors: probe connector angle, Data Acquisition Electronics (DAE) connector angle, use of a Quick Adaptor Change System (QACS). In DASY6/8, the sensor angle is assessed automatically during the alignment phase.

The alignment procedure consists of rotating the probe in the AMCC for an angle within the $[0^\circ - 360^\circ]$ in 10° steps. The sensor angle is defined as the angle giving the maximum H-field response for the sensor. The angle corresponds to the sensor in the axial direction (same orientation as the AMCC field).

Note: The calibration must be repeated after any change in the measurement instrumentation, especially when the probe / DAE has been remounted on the robot.

6.1.3. System Response Calibration

The sensitivity and frequency response of the AM1DVx probe is calibrated over the $[50\text{Hz} - 10\text{kHz}]$ frequency range using a multi-sine signal. The sines are at the center frequency of each 1/3 octave band.

The measurement is performed in the AMCC with the probe sensor in axial orientation. The Coil In channel of the Audio Magnetic Measurement Instrument (AMMI) measures the voltage over the AMCC internal shunt, which is proportional to the magnetic field in the AMMI. In parallel, the Probe In channel measures the amplified signal picked up by the probe coil. The sensitivity of the probe in $\text{V}/(\text{A}/\text{m})$ is defined as the voltage ratio at 1 kHz. The frequency response in dB is defined as the ratio between the voltages in each 1/3 octave band normalized to the 1 kHz ratio.

The obtained sensitivity is compared to the one from the probe configuration file for verification purposes. A warning is issued if the deviation exceeds 2 %.

6.2. AMMI Audio Output Calibration

The audio output calibration of the AMMI is performed as described below:

- Connect Audio Out to Coil In on the AMMI and click on Calibrate.
- Click on the Calibrate button.
- Once calibration is complete, re-establish the cabling illustrated in Test Setup Diagram §5.1.

6.3. Codec / System Delay Measurements

Codec / system delay measurements are calculated using the guidance from SPEAG's *DASY6/8 Module HAC System Handbook §7.3.2.4*:

- A time delay might occur in the audio signal path (latency of the codec, Windows settings ...). For accurate measurements, the system must consider this delay, and shift in time the probe readings accordingly.
- Module HAC features automated measurement of the delay. The assessed delay will then be used for the subsequent desired ABM signal level and undesired ABM field level measurements.
- The delay is measured by pressing the Assess Delay button under the Scan Control section of the Measurement tab. The system must be ready to measure, and the DUT must be transmitting in the desired test mode.
- A scan with reduced resolution will be performed and the delay will be assessed at the measured maximum.
- This measurement must be repeated after every change in the hardware setup, or when a different DUT / Codec is used.

6.4. Compute Gain Settings

Gain settings are computed using the following procedure:

- Define the Scan Type as Signal in the Scan Type section.
- Specify the Input Level and Codec Delay in the Base Station Simulator Settings.
 - Input level refers to full scale input level equivalent to 3.14 dBm0.
 - Input level of 1V is used for R&S CMW500 Base Station Simulator.
 - Input level of 1V is used for R&S CMX500
 - The codec delay can be measured automatically using the procedure described above in §6.3 above.
- Enter the desired speech level in dBm0. Refer to §5.2 for applicable Reference Input Levels.
- Specify the audio file and the measurement duration to be used for the area and frequency response scans.
 - Use Audio file 48k_voice_1kHz_1s.wav for ABMd and ABMu measurements.
 - Use Audio file 48k_voice_300-3000_2s.wav for Frequency Response measurements.
- Click on Compute Gain Settings. The properties of the audio file, such as the bandwidth compensation factor (BWC), peak value, etc. will be automatically computed. In addition, the audio file scaling (also called gain) will be calculated. A popup is displayed in case the resulting gain exceeds the AMMI dynamic range.

Computed Gain settings for each supported technology for CMRS evaluations is illustrated in the table below:

SAR 11

Computed Gain Settings						
Technology	Signal Type	Speech Level (dBm0)	Peak to Full Scale (dB)	Peak to RMS Scale (dB)	BWC (dB)	Scaling (Gain) (dB)
GSM	Voice 1 kHz	-16.0	-0.37	15.74	0.07	-12.47
	Voice 300-3kHz	-16.0	0	21.57	10.81	-6.64
W-CDMA	Voice 1 kHz	-16.0	-0.37	15.74	0.07	-12.5
	Voice 300-3kHz	-16.0	0	21.57	10.81	-6.67
VoLTE	Voice 1 kHz	-16.0	-0.37	15.74	0.07	-12.48
	Voice 300-3kHz	-16.0	0	21.57	10.81	-6.65
VoNR	Voice 1 kHz	-16.0	-0.37	15.74	0.07	-12.47
	Voice 300-3kHz	-16.0	0	21.57	10.81	-6.63
VoWiFi	Voice 1 kHz	-16.0	-0.37	15.74	0.07	-11.02
	Voice 300-3kHz	-16.0	0	21.57	10.81	-5.19

6.5. Over the Top (OTT)

For GSM, W-CDMA, LTE, 5G NR and Wi-Fi, the procedures outlined in §6.4 above were followed to compute the appropriate Gain settings for OTT measurements.

Computed Gain settings for each supported technology for OTT evaluations is illustrated in the table below:

SAR 11

Computed Gain Settings						
Technology	Signal Type	Speech Level (dBm0)	Peak to Full Scale (dB)	Peak to RMS Scale (dB)	BWC (dB)	Scaling (Gain) (dB)
GSM	Voice 1 kHz	-16.0	-0.37	15.74	0.07	-12.13
	Voice 300-3kHz	-16.0	0	21.57	10.81	-6.3
W-CDMA	Voice 1 kHz	-16.0	-0.37	15.74	0.07	-12.12
	Voice 300-3kHz	-16.0	0	21.57	10.81	-6.29
LTE	Voice 1 kHz	-16.0	-0.37	15.74	0.07	-12.12
	Voice 300-3kHz	-16.0	0	21.57	10.81	-6.29
5G NR	Voice 1 kHz	-16.0	-0.37	15.74	0.07	-12.14
	Voice 300-3kHz	-16.0	0	21.57	10.81	-6.31
WLAN	Voice 1 kHz	-16.0	-0.37	15.74	0.07	-12.13
	Voice 300-3kHz	-16.0	0	21.57	10.81	-6.3

7. T-coil Measurement Criteria

7.1. Frequency Response

The frequency response of the magnetic field, measured in 1/3 octave bands, shall follow the response curve specified in this subclause, over the frequency range 300 Hz to 3 kHz.

Figure 6.4 and Figure 6.5 provide the boundaries for the specified frequency. These response curves are for true field strength measurements of the T-Coil signal. Thus the 6 dB/octave probe response has been corrected from the raw readings.

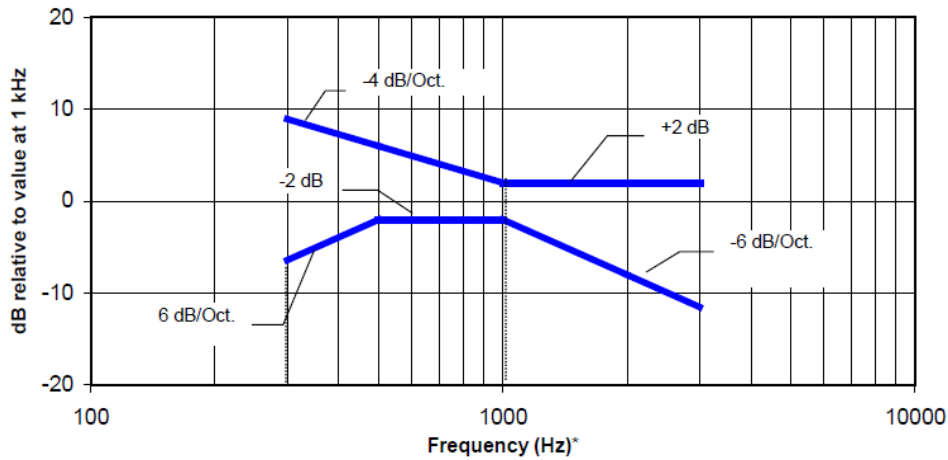

NOTE—Frequency response is between 300 Hz and 3 kHz.

Figure 6.4—Magnetic field frequency response for WDs with a maximum field ≤ -15 dB(A/m) at 1 kHz

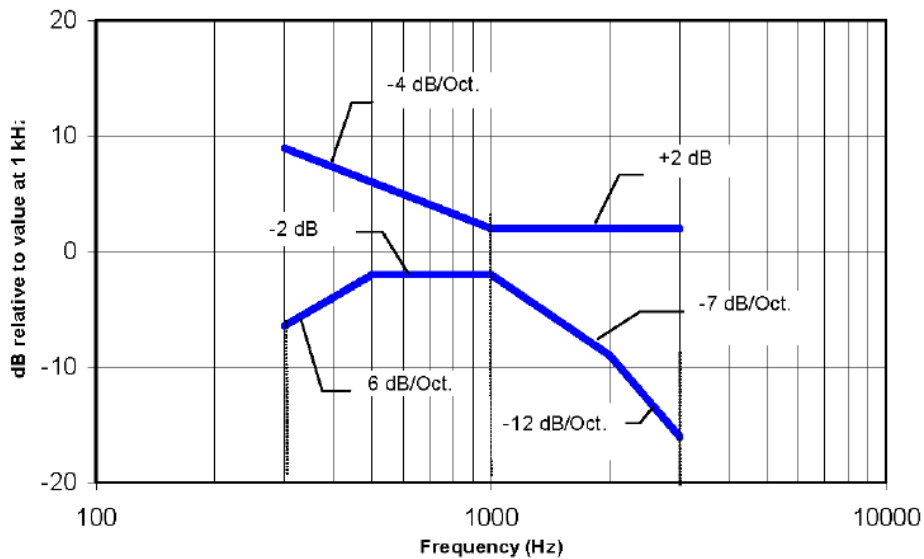

NOTE—Frequency response is between 300 Hz and 3000 Hz.

Figure 6.5—Magnetic field frequency response for WDs with a maximum field that exceeds -15 dB(A/m) at 1 kHz

7.2. Coupling Mode Requirements

In order to comply with the requirements for T-Coil use, a WD's tested operating modes shall simultaneously meet the requirements for minimum desired ABM signal level and maximum undesired ABM field contained in this subclause at the minimum specified number of scanned locations.

When measured as specified in this standard, there are two groups of qualifying measurement points:

Primary group: A qualifying measurement point shall have its T-Coil signal, desired ABM signal, ≥ -18 dB(A/m) at 1 kHz, in a 1/3 octave band filter. These measurements shall be made with the WD operating at a reference input level as specified in Table 6.1. Simultaneously, the qualifying measurement point shall have its weighted magnetic noise, undesired ABM field ≤ -38 dB(A/m).

Secondary group: A qualifying measurement point shall have its weighted magnetic noise, undesired ABM field ≤ -38 dB(A/m). This group inherently includes all the members of the primary group.

These levels are designed to be compatible with hearing aids that produce the same acoustic output level for either an acoustic input level of 65 dB SPL or a magnetic input level of -25 dB(A/m) (56.2 mA/m)⁶ at either 1.0 kHz or 1.6 kHz. The hearing aid operational measurements are performed per ANSI S3.22-2014.

Measurement locations and reference plane to be used for the T-coil measurements.

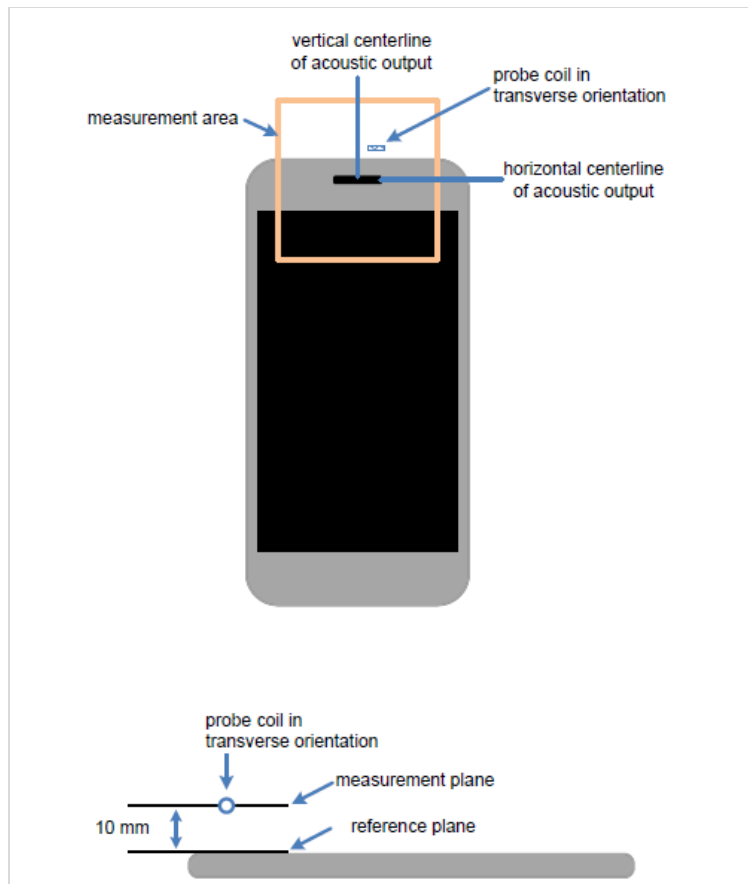

⁶ IEC 60118-1 refers to hearing aid output being the same for an acoustic input of 70 dB SPL and a magnetic input of 100 mA/m. Thus 31.6 mA/m is equivalent to an acoustic input of 60 dB SPL, and an acoustic input of 65 dB SPL is equivalent to 56.2 mA/m.

7.3. Desired ABM Signal and Undesired ABM Field Requirements

For a WD that is expected to operate primarily in radio access technologies that include 2G GSM for legacy support, the WD shall be qualified for telecoil compatibility one of two ways:

- The DUT shall be rated for telecoil use for all other voice operating modes, exclusive of 2G GSM, according to the criteria of §6.6.4.2 of ANSI C63.19 2019.
- If the DUT is to be rated for telecoil use in its 2G GSM operating modes, these modes shall be qualified according to the criteria of §6.6.4.3 of ANSI C63.19 2019.

7.3.1. Non-2G GSM Operating modes

The goal of this requirement is to ensure an adequate area where desired ABM signal is sufficiently strong to be heard clearly and a larger area where undesired ABM field is sufficiently low as to avoid undue annoyance. Qualifying measurement points shall fulfill the coupling mode requirements; both the primary and secondary group requirements shall be met:

- The primary group shall include at least 75 measurement points.
 - The secondary group shall include at least 300 contiguous measurement points.
- Additionally, to avoid an oddly shaped area of low noise, the secondary group shall include at least one longitudinal column of at least 10 contiguous qualifying points and at least one transverse row containing at least 15 contiguous qualifying points.

7.3.2. 2G GSM Operating modes

For 2G GSM operating mode(s), the qualifying measurement points shall fulfil the coupling mode requirements; both the primary and secondary group requirements shall be met:

- The primary group shall include at least 25 measurement points.
- The secondary group shall include at least 125 contiguous measurement points.

Additionally, to avoid an oddly shaped area of low noise, the secondary group shall include at least one longitudinal column of at least 10 contiguous qualifying points and at least one transverse row containing at least 15 contiguous qualifying points.

8. Device Under Test

Normal operation	Held to head		
Back Cover	The Back Cover is not removable		
Test sample information	S/N X0059LM9MH	IMEI N/A	Notes HAC Sample

8.1. Air Interfaces and Operating Mode

All air interfaces which support voice capabilities over a managed CMRS, or pre-installed OTT VoIP applications were evaluated.

Air Interface	Bands (MHz)	Type	C63.19 Tested	Simultaneous Transmitter	Name of Voice Service	Power Mode ³	Power Reduction	Audio Codecs Evaluated ¹
GSM	850	VO	Yes	Wi-Fi, BT, NB U-NII, 802.15.4 & 802.15.4ab NB	CMRS	Mode A	N/A	EFR, AMR-NB & AMR-WB
	1900						N/A	
	GPRS/EDGE	DT/VD	Yes	Wi-Fi, BT, NB U-NII, 802.15.4 & 802.15.4ab NB	FaceTime	Mode A	N/A	ACC-ELD
W-CDMA (UMTS)	850	VO	Yes	Wi-Fi, BT, NB U-NII, 802.15.4 & 802.15.4ab NB	CMRS	Mode A	N/A	AMR-NB & AMR-WB
	1700							
	1900	VD	Yes	Wi-Fi, BT, NB U-NII, 802.15.4 & 802.15.4ab NB	FaceTime	Mode A	N/A	ACC-ELD
LTE - FDD	700 (B12/13/17)	VD	Yes	5G NR, Wi-Fi, BT, NB U-NII, 802.15.4 & 802.15.4ab NB	CMRS FaceTime	Mode A	N/A	AMR-NB, AMR-WB, EVS, & ACC-ELD
	850 (B5/26)							
	1700 (B4/66)							
	1900 (B2/25)							
	2300 (B30)							
2500 (B7)								
LTE - TDD	2500 (B53)	VD	Yes	5G NR, Wi-Fi, BT, NB U-NII, 802.15.4 & 802.15.4ab NB	CMRS FaceTime	Mode A	N/A	AMR-NB, AMR-WB, EVS, & ACC-ELD
	2600 (B41)							
	3600 (B48)							
5G NR(FR1) FDD	700 (n12)	VD	Yes ²	LTE, Wi-Fi, BT, NB U-NII, 802.15.4 & 802.15.4ab NB	CMRS FaceTime	Mode A	N/A	AMR-NB, AMR-WB, EVS, & ACC-ELD
	850 (n5/n26)							
	1700 (n66/n70)							
	1900 (n2/n25)							
	2300 (n30)							
2500 (n7)								
5G NR(FR1) TDD	2500 (n53)	VD	Yes ²	LTE, Wi-Fi, BT, NB U-NII, 802.15.4 & 802.15.4ab NB	CMRS FaceTime	Mode A	N/A	AMR-NB, AMR-WB, EVS, & ACC-ELD
	2600 (n41)							
	3500 (n77 Block A)							
	3700 (n48)							
	3900 (n77 Block C)							
Type VO: Legacy Cellular Voice Service DT: Digital Transport only (no voice) VD: IP Voice Service over Digital Transport CMRS: Commercial Mobile Radio Service				Note(s): 1. For protocols not listed in Table 6.1 of ANSI C63.19-2019, the average speech level of -20 dBm0 was used. Refer to §5.2 for reference input levels. 2. 5G NR (VoNR) is supported: manufacturer states that 5G NR (VoNR) uses the same protocol, Codec(s) and bitrates as LTE (VoLTE). 3. For all air interfaces, the maximum held-to-head output power was used for T-Coil evaluations. The maximum held-to-head output power is Mode A for WWAN operating modes and Power State 1 Mode A for WLAN operating modes. Refer to §9 & §10 for T-Coil evaluations.				

Air Interfaces and Operating Modes

Air Interface	Bands (MHz)	Type	C63.19 Tested	Simultaneous Transmitter	Name of Voice Service	Power Mode ³	Power Reduction	Audio Codecs Evaluated ¹
Wi-Fi	2450	VD	Yes	WWAN, NB U-NII & 802.15.4ab	CMRS FaceTime	Power State 1 Mode A	N/A	AMR-NB, AMR-WB, EVS, & ACC-ELD
	U-NII-1							
	U-NII-2A							
	U-NII-2C							
	U-NII-3	VD	Yes	WWAN, BT, 802.15.4, & 802.15.4ab NB				
	U-NII-5 (VLP, SP, LPI)							
	U-NII-6 (LPI)							
	U-NII-7 (VLP, SP, LPI)							
U-NII-8 (LPI)	VD	No ²	WWAN, BT, 802.15.4, & 802.15.4ab NB					
NB U-NII	5200 (U-NII-1)	DT	N/A	WWAN, Wi-Fi 2.4 GHz	N/A	N/A	N/A	N/A
	5800 (U-NII-3)							
802.15ab NB	5800 (U-NII-3)	DT	N/A	WWAN, BT, 802.15.4 & Wi-Fi ²	N/A	N/A	N/A	N/A
802.15.4	2450	DT	N/A	WWAN, 802.15.4ab NB & Wi-Fi 5/6G	N/A	N/A	N/A	N/A
BT	2.4GHz	DT	N/A	WWAN, 802.15.4ab NB & Wi-Fi 5/6G	N/A	N/A	N/A	N/A
MSS	1600	DT	N/A	N/A	N/A	N/A	N/A	N/A
NFC	13	DT	N/A	WWAN, BT, Wi-Fi 2.4G, Wi-Fi 5/6G, 802.15.4	N/A	N/A	N/A	N/A
UWB (Ultra-Wideband)	6500	DT	N/A	N/A	N/A	N/A	N/A	N/A
	8000							
Type VO: Legacy Cellular Voice Service DT: Digital Transport only (no voice) VD: IP Voice Service over Digital Transport CMRS: Commercial Mobile Radio Service				Note(s): 1. For protocols not listed in Table 6.1 of ANSI C63.19-2019, the average speech level of -20 dBm0 was used. Refer to §5.2 for reference input levels. 2. Supported Frequency > 6GHz. ANSI C63,19 2019 only requires HAC evaluations for Technologies/Frequencies < 6GHz. 3. For all air interfaces, the maximum held-to-head output power was used for T-Coil evaluations. The maximum held-to-head output power is Mode A for WWAN operating modes and Power State 1 Mode A for WLAN operating modes. Refer to §9 & §10 for T-Coil evaluations.				

9. Investigations (Antenna, Codec, & Air Interface)

In order to comply with the requirements for T-Coil use, a WD's tested operating modes shall simultaneously meet the requirements for minimum desired ABM signal level and maximum undesired ABM field contained in this subclause at the minimum specified number of scanned locations.

When measured as specified in this standard, there are two groups of qualifying measurement points:

Primary group: A qualifying measurement point shall have its T-Coil signal, desired ABM signal, ≥ -18 dB(A/m) at 1 kHz, in a 1/3 octave band filter. These measurements shall be made with the WD operating at a reference input level as specified in Table 6.1. Simultaneously, the qualifying measurement point shall have its weighted magnetic noise, undesired ABM field ≤ -38 dB(A/m).

Secondary group: A qualifying measurement point shall have its weighted magnetic noise, undesired ABM field ≤ -38 dB(A/m). This group inherently includes all the members of the primary group.

2G GSM Operating modes

For 2G GSM operating mode(s), the qualifying measurement points shall fulfil the coupling mode requirements; both the primary and secondary group requirements shall be met:

- The primary group shall include at least 25 measurement points.
- The secondary group shall include at least 125 contiguous measurement points.

Additionally, to avoid an oddly shaped area of low noise, the secondary group shall include at least one longitudinal column of at least 10 contiguous qualifying points and at least one transverse row containing at least 15 contiguous qualifying points.

Non-2G GSM Operating modes

Qualifying measurement points shall fulfill the coupling mode requirements; both the primary and secondary group requirements shall be met:

- The primary group shall include at least 75 measurement points.
- The secondary group shall include at least 300 contiguous measurement points.

Additionally, to avoid an oddly shaped area of low noise, the secondary group shall include at least one longitudinal column of at least 10 contiguous qualifying points and at least one transverse row containing at least 15 contiguous qualifying points.

5G NR Operating modes

The DUT supports 5G NR, Voice over New Radio (VoNR). Per the manufacturer, 5G NR (VoNR) uses the same protocol, Codec(s) and bitrates as LTE (VoLTE). Investigations were performed on LTE (VoLTE) and the worst-case Port/Antenna/Codec/Air Interface configurations from LTE (VoLTE) was used for 5G NR (VoNR) evaluations. Refer to §10 for 5G NR (VoNR) evaluations.

All Operating modes

For all air interfaces, the maximum held-to-head output power was used for T-Coil evaluations. The maximum held-to-head output power is Mode A for WWAN operating modes and Power State 1 Mode A for WLAN operating modes. Refer to §9 & §10 for T-Coil evaluations.

The worst-case configuration is determined by the lowest margin of Primary Group Contiguous Points. The margin Primary Group Contiguous Points is calculated by subtracting the Primary Group points coupling mode requirement (25 for GSM modes and 75 for non-GSM modes) from the measured Primary Group Contiguous Points. The lowest margin of Primary Group Contiguous Points will be highlighted in each table.

For WWAN technologies, the DUT utilizes an Antenna - Port mapping feature. A Port is a collection (cluster) of antennas. Once the Port and Frequency Band has been selected, the transmitting Antenna is auto selected. Below is a description of the Port - Antenna mapping for the DUT.

Port	Frequency Band	Antenna
A	LB	1
	LMB	1
	MBHB	1
	UHB	7
B	LB	2
	LMB	2
	MBHB	2
	UHB	8
C	MBHB	3
	UHB	9
D	MBHB	4
	UHB	4

LB = Lower Band (617 MHz - 960 MHz)

LMB = Lower - Mid Band (1427 MHz - 1700 MHz)

MBHB = Mid Band - High Band (1710 MHz - 2960 MHz)

UHB = Ultra High Band (3300 MHz - 4200 MHz)

An investigation was performed to determine the worst-case Port for each Licensed technology. All subsequent measurements were determined by this investigation.

The device supports four (4) WLAN Tx antennas:

Antenna	Technology
3 (Lower)	Wi-Fi 2.4GHz
	Bluetooth
4 (Upper)	Wi-Fi 2.4GHz
	Bluetooth
5 (Lower)	Wi-Fi 5GHz
	Bluetooth
6 (Upper)	Wi-Fi 5GHz
	Bluetooth

An investigation was performed to determine the worst-case WLAN Antenna. All subsequent measurements were determined by this investigation.

9.1. CMRS

9.1.1. Antenna Investigation

Mode:	Channel and Frequency	Bandwidth (Data Rate)	SCS (kHz)	Power Mode	Port/Antenna	Orientation	Frequency Response	Ambient Noise dB(A/m)	Primary Group Contiguous Pts	Secondary Group Contiguous Pts	Secondary Group Max Longitudinal	Secondary Group Max Transverse	Primary Group Contiguous Pts Margin	Secondary Group Contiguous Pts Margin
GSM 1900 Voice Coder Speechcodec Low	661 1880 MHz	N/A	N/A	Mode A	A (ANT 1)	Transverse	Pass	-56.42	142	501	26	26	117	376
					B (ANT 2)	Transverse	Pass	-56.42	228	589	26	26	203	464
					C (ANT 3)	Transverse	Pass	-56.42	143	503	26	26	118	378
					D (ANT 4)	Transverse	Pass	-56.42	208	564	26	26	183	439
W-CDMA BII Rel. 99 AMR-NB: 4.75 kbps	9400 1880 MHz	N/A	N/A	Mode A	A (ANT 1)	Transverse	Pass	-56.42	318	676	26	26	243	376
					B (ANT 2)	Transverse	Pass	-56.42	316	676	26	26	241	376
					C (ANT 3)	Transverse	Pass	-56.42	317	676	26	26	242	376
					D (ANT 4)	Transverse	Pass	-56.42	315	676	26	26	240	376
LTE Band 25 QPSK RB 1/0 AMR-NB: 4.75 kbps	26365 1882.5 MHz	20 MHz	N/A	Mode A	A (ANT 1)	Transverse	Pass	-56.24	317	676	26	26	242	376
					B (ANT 2)	Transverse	Pass	-56.24	316	674	26	26	241	374
					C (ANT 3)	Transverse	Pass	-56.24	314	673	26	26	239	373
					D (ANT 4)	Transverse	Pass	-56.24	317	675	26	26	242	375
LTE Band 41 QPSK RB 1/0 AMR-NB: 4.75 kbps	40620 2593 MHz	20 MHz	N/A	Mode A	A (ANT 1)	Transverse	Pass	-56.24	309	667	26	26	234	367
					B (ANT 2)	Transverse	Pass	-56.24	238	582	26	26	163	282
					C (ANT 3)	Transverse	Pass	-56.24	293	641	26	26	218	341
					D (ANT 4)	Transverse	Pass	-56.24	234	571	26	26	159	271
802.11b AMR-NB: 4.75 kbps	6 2437 MHz	DSSS 1 Mbps 20 MHz BW	N/A	Power State 1 Mode A	ANT 3	Transverse	Pass	-56.18	332	669	26	26	257	369
					ANT 4	Transverse	Pass	-56.18	336	669	26	26	261	369
802.11a AMR-NB: 4.75 kbps	36 5180 MHz	BPSK 6 Mbps 20 MHz BW	N/A	Power State 1 Mode A	ANT 5	Transverse	Pass	-56.18	350	676	26	26	275	376
					ANT 6	Transverse	Pass	-56.18	346	676	26	26	271	376

Note(s):

- PORT A (ANT 1) has been determined to be the worst-case antenna for GSM.
- PORT D (ANT 4) has been determined to be the worst-case antenna for W-CDMA.
- PORT C (ANT 3) has been determined to be the worst-case antenna for LTE-FDD.
- PORT D (ANT 4) has been determined to be the worst-case antenna for LTE-TDD.
- ANT 3 has been determined to be the worst-case antenna for Wi-Fi 2.4 GHz.
- ANT 6 has been determined to be the worst-case antenna for Wi-Fi 5 GHz.

9.1.2. Codec Investigation

An investigation between the various codec configurations (Low/Mid/High bit rates for Narrowband, Wideband and EVS) was performed to determine the worst-case bit rates for each voice service type. The table below compares the varying codec configurations. A codec investigation was performed on one band of each W-CDMA, LTE FDD, LTE TDD, Wi-Fi 2.4GHz and Wi-Fi 5GHz.

W-CDMA Codec Investigation

W-CDMA Codec Investigation													
Band/Channel/ Bandwidth	Power Modes	Port/Antenna	Orientation	Codec	Bitrate (kbps)	Frequency Response	Ambient Noise dB(A/m)	Primary Group Contiguous Pts	Secondary Group Contiguous Pts	Secondary Group Max Longitudinal	Secondary Group Max Transverse	Primary Group Contiguous Pts Margin	Secondary Group Contiguous Pts Margin
W-CDMA BII Rel. 99 Ch. 9400 1880 MHz	Mode A	D (ANT 4)	Transverse	AMR-NB	4.75	Pass	-56.42	315	676	26	26	240	376
					7.4	Pass	-56.42	320	676	26	26	245	376
					12.2	Pass	-56.42	323	676	26	26	248	376
				AMR-WB	6.6	Pass	-56.24	252	676	26	26	177	376
					15.85	Pass	-56.24	265	676	26	26	190	376
					23.85	Pass	-56.24	265	676	26	26	190	376

Note(s):

- For W-CDMA, it is observed that 6.60 kbps is the worst-case bit rate.

VoLTE Codec Investigation

VoLTE Codec Investigation													
Band/Channel/ Bandwidth	Power Mode	Port/Antenna	Orientation	Codec	Bitrate (kbps)	Frequency Response	Ambient Noise dB(A/m)	Primary Group Contiguous Pts	Secondary Group Contiguous Pts	Secondary Group Max Longitudinal	Secondary Group Max Transverse	Primary Group Contiguous Pts Margin	Secondary Group Contiguous Pts Margin
LTE Band 25 Ch. 26365 QPSK RB 1/0 20 MHz BW	Mode A	C (ANT 3)	Transverse	AMR-NB	4.75	Pass	-56.24	314	673	26	26	239	373
					7.4	Pass	-56.24	319	676	26	26	244	376
					12.2	Pass	-56.24	321	676	26	26	246	376
				AMR-WB	6.6	Pass	-56.24	249	676	26	26	174	376
					15.85	Pass	-56.24	265	676	26	26	190	376
					23.85	Pass	-56.24	264	676	26	26	189	376
				EVS	5.9	Pass	-56.24	237	676	26	26	162	376
					9.6	Pass	-56.24	326	676	26	26	251	376
					24.4	Pass	-56.24	326	676	26	26	251	376
LTE Band 41 Ch. 40620 QPSK RB 1/0 20 MHz BW	Mode A	D (ANT 4)	Transverse	AMR-NB	4.75	Pass	-56.24	234	571	26	26	159	271
					7.4	Pass	-56.24	236	574	26	26	161	274
					12.2	Pass	-56.24	237	572	26	26	162	272
				AMR-WB	6.6	Pass	-56.24	180	573	26	26	105	273
					15.85	Pass	-56.24	193	573	26	26	118	273
					23.85	Pass	-56.24	193	572	26	26	118	272
				EVS	5.9	Pass	-56.24	175	574	26	26	100	274
					9.6	Pass	-56.24	246	575	26	26	171	275
					24.4	Pass	-56.24	243	571	26	26	168	271

Note(s):

- For LTE-FDD, it is observed that 5.90 kbps is the worst-case bit rate.
- For LTE-TDD, it is observed that 5.90 kbps is the worst-case bit rate.

VoWiFi Codec Investigation

VoWiFi Codec Investigation													
Band/Channel/ Bandwidth	Power Mode	Antenna	Orientation	Codec	Bitrate (kbps)	Frequency Response	Ambient Noise dB(A/m)	Primary Group Contiguous Pts	Secondary Group Contiguous Pts	Secondary Group Max Longitudinal	Secondary Group Max Transverse	Primary Group Contiguous Pts Margin	Secondary Group Contiguous Pts Margin
DSSS 1 Mbps Ch. 6 20 MHz BW	Power State 1 Mode A	ANT 3	Transverse	AMR-NB	4.75	Pass	-56.18	332	669	26	26	257	369
					7.4	Pass	-56.18	348	676	26	26	273	376
					12.2	Pass	-56.18	352	676	26	26	277	376
				AMR-WB	6.6	Pass	-56.18	269	676	26	26	194	376
					15.85	Pass	-56.18	276	676	26	26	201	376
					23.85	Pass	-56.18	277	676	26	26	202	376
				EVS	5.9	Pass	-56.18	286	676	26	26	211	376
					9.6	Pass	-56.18	357	676	26	26	282	376
					24.4	Pass	-56.18	359	676	26	26	284	376
BPSK 802.11a Ch. 36 6 Mbps	Power State 1 Mode A	ANT 6	Transverse	AMR-NB	4.75	Pass	-56.18	346	676	26	26	271	376
					7.4	Pass	-56.18	350	676	26	26	275	376
					12.2	Pass	-56.18	353	676	26	26	278	376
				AMR-WB	6.6	Pass	-56.18	268	676	26	26	193	376
					15.85	Pass	-56.18	276	676	26	26	201	376
					23.85	Pass	-56.18	274	676	26	26	199	376
				EVS	5.9	Pass	-56.18	290	676	26	26	215	376
					9.6	Pass	-56.18	355	676	26	26	280	376
					24.4	Pass	-56.18	355	676	26	26	280	376

Note(s):

- For Wi-Fi 2.4 GHz, it is observed that 6.60 kbps is the worst-case bit rate.
- For Wi-Fi 5 GHz, it is observed that 6.60 kbps is the worst-case bit rate.

9.1.3. Air Interface Investigation

A limited set of bands/channels/bandwidths were evaluated to confirm that there is no effect to the ABM levels when changing the band/channel/bandwidth.

W-CDMA Air Interface Investigation

W-CDMA Air Interface Investigation												
Mode:	Power Modes	Port/Antenna	Channel and Frequency	Orientation	Frequency Response	Ambient Noise dB(A/m)	Primary Group Contiguous Pts	Secondary Group Contiguous Pts	Secondary Group Max Longitudinal	Secondary Group Max Transverse	Primary Group Contiguous Pts Margin	Secondary Group Contiguous Pts Margin
W-CDMA Band II Rel. 99 AMR-WB: 6.6 kbps	Mode A	D (ANT 4)	9262 1852.4 MHz	Transverse	Pass	-56.24	253	676	26	26	178	376
			9400 1880.0 MHz	Transverse	Pass	-56.24	252	676	26	26	177	376
			9538 1907.6 MHz	Transverse	Pass	-56.24	253	676	26	26	178	376

Note(s):

- For all subsequent tests for W-CDMA, middle channel was used in conjunction with the worst-case bit rate found in §9.1.2.

VoLTE Air Interface Investigation

VoLTE Air Interface Investigation															
Mode:	Bandwidth	Power Mode	Port/Antenna	Channel and Frequency	RB Allocation		Orientation	Frequency Response	Ambient Noise dB(A/m)	Primary Group Contiguous Pts	Secondary Group Contiguous Pts	Secondary Group Max Longitudinal	Secondary Group Max Transverse	Primary Group Contiguous Pts Margin	Secondary Group Contiguous Pts Margin
LTE Band 25 QPSK EVS: 5.9 kbps	20 MHz	Mode A	C (ANT 3)	26365 1882.5 MHz	1	0	Transverse	Pass	-56.24	237	676	26	26	162	376
					100	0	Transverse	Pass	-56.24	235	676	26	26	160	376
LTE Band 25 16QAM EVS: 5.9 kbps	20 MHz	Mode A	C (ANT 3)	26365 1882.5 MHz	100	0	Transverse	Pass	-56.24	239	674	26	26	164	374
LTE Band 25 64QAM EVS: 5.9 kbps	20 MHz	Mode A	C (ANT 3)	26365 1882.5 MHz	100	0	Transverse	Pass	-56.24	241	674	26	26	166	374
LTE Band 25 256QAM EVS: 5.9 kbps	20 MHz	Mode A	C (ANT 3)	26365 1882.5 MHz	100	0	Transverse	Pass	-56.24	241	675	26	26	166	375
LTE Band 25 QPSK EVS: 5.9 kbps	1.4 MHz	Mode A	C (ANT 3)	26365 1882.5 MHz	6	0	Transverse	Pass	-56.24	240	674	26	26	165	374
LTE Band 41 QPSK EVS: 5.9 kbps	20 MHz	Mode A	D (ANT 4)	40620 2593 MHz	1	0	Transverse	Pass	-56.24	175	574	26	26	100	274
					100	0	Transverse	Pass	-56.24	178	574	26	26	103	274
LTE Band 41 16QAM EVS: 5.9 kbps	20 MHz	Mode A	D (ANT 4)	40620 2593 MHz	1	0	Transverse	Pass	-56.24	165	572	26	26	90	272
LTE Band 41 64QAM EVS: 5.9 kbps	20 MHz	Mode A	D (ANT 4)	40620 2593 MHz	1	0	Transverse	Pass	-56.24	172	572	26	26	97	272
LTE Band 41 256QAM EVS: 5.9 kbps	20 MHz	Mode A	D (ANT 4)	40620 2593 MHz	1	0	Transverse	Pass	-56.24	173	575	26	26	98	275
LTE Band 41 16 QAM EVS: 5.9 kbps	5 MHz	Mode A	D (ANT 4)	40620 2593 MHz	1	0	Transverse	Pass	-56.24	169	575	26	26	94	275

Note(s):

- For all subsequent tests for LTE-FDD, middle channel, QPSK modulation, and 100% RB size and low RB allocation was used in conjunction with the worst-case bit rate found in §9.1.2.
- For all subsequent tests for LTE-TDD, middle channel, 16QAM modulation, and 1% RB size and low RB allocation was used in conjunction with the worst-case bit rate found in §9.1.2.

VoWiFi Air Interface Investigation

VoWi-Fi Air Interface Investigation														
Mode:	Channel and Frequency	Power Mode	Antenna	Modulation/index	Data Rate	Orientation	Frequency Response	Ambient Noise dB(A/m)	Primary Group Contiguous Pts	Secondary Group Contiguous Pts	Secondary Group Max Longitudinal	Secondary Group Max Transverse	Primary Group Contiguous Pts Margin	Secondary Group Contiguous Pts Margin
802.11b AMR-WB: 6.6 kbps	6 2437 MHz	Power State 1 Mode A	ANT 3	DSSS	1 Mbps	Transverse	Pass	-56.18	269	676	26	26	194	376
				CCK	5.5 Mbps	Transverse	Pass	-56.18	269	676	26	26	194	376
					11 Mbps	Transverse	Pass	-56.18	269	676	26	26	194	376
802.11g AMR-WB: 6.6 kbps	6 2437 MHz	Power State 1 Mode A	ANT 3	DSSS	1 Mbps	Transverse	Pass	-56.18	270	676	26	26	195	376
802.11n AMR-WB: 6.6 kbps	6 2437 MHz	Power State 1 Mode A	ANT 3	MCS0	6.5 Mbps	Transverse	Pass	-56.18	267	676	26	26	192	376
802.11ax AMR-WB: 6.6 kbps	6 2437 MHz	Power State 1 Mode A	ANT 3	MCS0	7.3 Mbps	Transverse	Pass	-56.18	268	676	26	26	193	376
802.11a AMR-WB: 6.6 kbps	36 5180 MHz	Power State 1 Mode A	ANT 6	BPSK	6 Mbps	Transverse	Pass	-56.18	268	676	26	26	193	376
				QPSK	18 Mbps	Transverse	Pass	-56.18	269	676	26	26	194	376
				64QAM	54 Mbps	Transverse	Pass	-56.18	269	676	26	26	194	376
802.11n 20 MHz AMR-WB: 6.6 kbps	36 5180 MHz	Power State 1 Mode A	ANT 6	MCS0	6.5 Mbps	Transverse	Pass	-56.18	262	669	26	26	187	369
802.11n 40 MHz AMR-WB: 6.6 kbps	38 5190 MHz	Power State 1 Mode A	ANT 6	MCS0	13.5 Mbps	Transverse	Pass	-56.18	264	670	26	26	189	370
802.11ac 20 MHz AMR-WB: 6.6 kbps	36 5180 MHz	Power State 1 Mode A	ANT 6	MCS0	6.5 Mbps	Transverse	Pass	-56.18	263	670	26	26	188	370
802.11ac 40 MHz AMR-WB: 6.6 kbps	38 5190 MHz	Power State 1 Mode A	ANT 6	MCS0	13.5 Mbps	Transverse	Pass	-56.18	262	669	26	26	187	369
802.11ac 80 MHz AMR-WB: 6.6 kbps	42 5210 MHz	Power State 1 Mode A	ANT 6	MCS0	29.3 Mbps	Transverse	Pass	-56.18	260	669	26	26	185	369
802.11ac 160 MHz AMR-WB: 6.6 kbps	50 5250 MHz	Power State 1 Mode A	ANT 6	MCS0	58.5 Mbps	Transverse	Pass	-56.18	262	669	26	26	187	369
802.11ax 20 MHz AMR-WB: 6.6 kbps	36 5180 MHz	Power State 1 Mode A	ANT 6	MCS0	8.6 Mbps	Transverse	Pass	-56.18	269	676	26	26	194	376
802.11ax 40 MHz AMR-WB: 6.6 kbps	38 5190 MHz	Power State 1 Mode A	ANT 6	MCS0	17.2 Mbps	Transverse	Pass	-56.18	268	676	26	26	193	376
802.11ax 80 MHz AMR-WB: 6.6 kbps	42 5210 MHz	Power State 1 Mode A	ANT 6	MCS0	36 Mbps	Transverse	Pass	-56.18	269	676	26	26	194	376
802.11ax 160 MHz AMR-WB: 6.6 kbps	50 5250 MHz	Power State 1 Mode A	ANT 6	MCS0	72 Mbps	Transverse	Pass	-56.18	269	676	26	26	194	376

Note(s):

- For all subsequent tests for Wi-Fi 2.4 GHz, 802.11n MCS0 6.5 Mbps was used in conjunction with the worst-case bit rate found in §9.1.2.
 - 802.11be has the same max output power, supports the same channel BWs (20MHz) and multiplexing as 802.11ax. Therefore, 802.11ax test results are representative of 802.11be.
- For all subsequent tests for Wi-Fi 5 GHz, 802.11ac VHT80 MHz MCS0 29.3 Mbps was used in conjunction with the worst-case bit rate found in §9.1.2.
 - 802.11be has the same max output power, supports the same channel BWs (20/40/80/160MHz) and multiplexing as 802.11ax. Therefore, 802.11ax test results are representative of 802.11be.

9.2. OTT Application

CMRS and OTT voice services support the same technologies, antennas and air interfaces. CMRS and OTT voice services require the same Reference input level of -16 dBm0 per ANSI C63.19 2019 §6.

Antenna, Codec (bit rates) and Air Interface investigations were conducted on CMRS voice services for supported technologies (Codec bit rate was measured separately for OTT voice services). For all subsequent OTT voice service testing, the worst-case CMRS Air interface configurations were used in conjunction with the worst-case bit rate found in §9.2.1 below.

9.2.1. Codec Investigation

The OTT Application did not support a means for the test lab to change the codec's (ACC-ELD) bit rates. When a VoIP call was established, the test lab recorded the bit rate used during that session, listed below, for the supported technologies: GSM, W-CDMA, LTE, 5G NR, Wi-Fi 2.4 GHz, and Wi-Fi 5 GHz

Codec Bit Rates

Codec Bit Rate			
Technology	Mode	Codec	Bit Rate (kbps)
GSM	EDGE	ACC-ELD	24
W-CDMA	HSPA	ACC-ELD	24
LTE	FDD	ACC-ELD	24
	TDD	ACC-ELD	24
5G NR	FDD	ACC-ELD	23
	TDD	ACC-ELD	23
Wi-Fi 2.4 GHz	802.11b	ACC-ELD	38
	802.11g	ACC-ELD	38
	802.11n	ACC-ELD	38
	802.11ax	ACC-ELD	38
Wi-Fi 5 GHz	802.11a	ACC-ELD	38
	802.11n HT20	ACC-ELD	38
	802.11n HT40	ACC-ELD	38
	802.11ac VHT20	ACC-ELD	38
	802.11ac VHT40	ACC-ELD	38
	802.11ac VHT80	ACC-ELD	38
	802.11ac VHT160	ACC-ELD	38
	802.11ax HE20	ACC-ELD	38
	802.11ax HE40	ACC-ELD	38
	802.11ax HE80	ACC-ELD	38
	802.11ax HE160	ACC-ELD	38

For all subsequent OTT testing, the measured bit rates above were used in conjunction with the worst-case air interfaces found in §9.1.3. Refer to §10 for OTT T-Coil Test Results.

10. HAC (T-coil) Test Results

Antenna, Codec (bit rates) and Air Interface investigations were conducted on CMRS voice services (Codec bit rate was measured separately for OTT voice services refer to §9.2.1). The worst-case antenna, codec (bit rate) and air interface configurations were used for final T-Coil testing for CMRS and OTT voice services. Please refer to tables below for final T-Coil Test Results.

GSM/W-CDMA Test Results

CMRS

Mode:	Channel and Frequency	Power Mode	Port/Antenna	Orientation	Frequency Response	Ambient Noise dB(A/m)	Primary Group Contiguous Pts	Secondary Group Contiguous Pts	Secondary Group Max Longitudinal	Secondary Group Max Transverse	Primary Group Contiguous Pts Margin	Secondary Group Contiguous Pts Margin	Plot Page #
GSM 850 Voice Coder Speechcodec Low	190 836.6 MHz	Mode A	A (ANT 1)	Transverse	Pass	-56.42	251	611	26	26	226	486	
GSM 1900 Voice Coder Speechcodec Low	661 1880 MHz	Mode A	A (ANT 1)	Transverse	Pass	-56.42	142	501	26	26	117	376	1 - 2
W-CDMA Band II Rel. 99 AMR-WB: 6.6 kbps	9400 1880 MHz	Mode A	D (ANT 4)	Transverse	Pass	-56.24	252	676	26	26	177	376	3 - 4
W-CDMA Band IV Rel. 99 AMR-WB: 6.6 kbps	1413 1732.6 MHz	Mode A	D (ANT 4)	Transverse	Pass	-56.24	250	676	26	26	175	376	
W-CDMA Band V Rel. 99 AMR-WB: 6.6 kbps	4183 836.6 MHz	Mode A	B (ANT 2)	Transverse	Pass	-56.24	249	676	26	26	174	376	

OTT

Mode:	Channel and Frequency	Power Mode	Port/Antenna	Orientation	Frequency Response	Ambient Noise dB(A/m)	Primary Group Contiguous Pts	Secondary Group Contiguous Pts	Secondary Group Max Longitudinal	Secondary Group Max Transverse	Primary Group Contiguous Pts Margin	Secondary Group Contiguous Pts Margin	Plot Page #
GSM 850 EGDE/EGPRS ACC-ELD: 24 kbps	190 836.6 MHz	Mode A	A (ANT 1)	Transverse	Pass	-56.18	183	661	26	26	158	536	5 - 6
GSM 1900 EGDE/EGPRS ACC-ELD: 24 kbps	661 1880 MHz	Mode A	A (ANT 1)	Transverse	Pass	-56.18	146	622	26	26	121	497	
W-CDMA Band II HSPA+ ACC-ELD: 24 kbps	9400 1880 MHz	Mode A	D (ANT 4)	Transverse	Pass	-56.18	196	674	26	26	121	374	
W-CDMA Band IV HSPA+ ACC-ELD: 24 kbps	1413 1732.6 MHz	Mode A	D (ANT 4)	Transverse	Pass	-56.18	194	674	26	26	119	374	7 - 8
W-CDMA Band V HSPA+ ACC-ELD: 24 kbps	4183 836.6 MHz	Mode A	B (ANT 2)	Transverse	Pass	-56.18	194	674	26	26	119	374	9 - 10

LTE (VoLTE) Test Results

CMRS

Mode:	Bandwidth (Data Rate)	Power Mode	Port/Antenna	Channel and Frequency	RB Allocation	Orientation	Frequency Response	Ambient Noise dB(A/m)	Primary Group Contiguous Pts	Secondary Group Contiguous Pts	Secondary Group Max Longitudinal	Secondary Group Max Transverse	Primary Group Contiguous Pts Margin	Secondary Group Contiguous Pts Margin	Plot Page #
LTE Band 7 QPSK EVS: 5.9 kbps	20 MHz	Mode A	C (ANT 3)	21100 2535 MHz	100 0	Transverse	Pass	-56.24	227	674	26	26	152	374	
LTE Band 12 QPSK EVS: 5.9 kbps	10 MHz	Mode A	B (ANT 2)	23095 707.5 MHz	50 0	Transverse	Pass	-56.24	234	676	26	26	159	376	
LTE Band 13 QPSK EVS: 5.9 kbps	10 MHz	Mode A	B (ANT 2)	23230 762 MHz	50 0	Transverse	Pass	-56.24	236	676	26	26	161	376	
LTE Band 25 QPSK EVS: 5.9 kbps	20 MHz	Mode A	C (ANT 3)	26365 1882.5 MHz	100 0	Transverse	Pass	-56.24	235	676	26	26	160	376	
LTE Band 26 QPSK EVS: 5.9 kbps	15 MHz	Mode A	B (ANT 2)	26865 831.5 MHz	75 0	Transverse	Pass	-56.24	232	676	26	26	157	376	
LTE Band 30 QPSK EVS: 5.9 kbps	10 MHz	Mode A	C (ANT 3)	27710 2310 MHz	50 0	Transverse	Pass	-56.24	236	676	26	26	161	376	
LTE Band 41 PC3 16 QAM EVS: 5.9 kbps	20 MHz	Mode A	D (ANT 4)	40620 2593 MHz	1 0	Transverse	Pass	-56.24	165	572	26	26	90	272	
LTE Band 41 PC2 16 QAM EVS: 5.9 kbps	20 MHz	Mode A	D (ANT 4)	40620 2593 MHz	1 0	Transverse	Pass	-56.24	160	563	26	26	85	263	
LTE Band 48 PC3 16 QAM EVS: 5.9 kbps	20 MHz	Mode A	D (ANT 4)	55990 3625 MHz	1 0	Transverse	Pass	-56.24	203	624	26	26	128	324	
LTE Band 53 PC3 16 QAM EVS: 5.9 kbps	10 MHz	Mode A	B (ANT 2)	60197 2489.2 MHz	1 0	Transverse	Pass	-56.24	242	674	26	26	167	374	
LTE Band 66 QPSK EVS: 5.9 kbps	20 MHz	Mode A	C (ANT 3)	132322 1745 MHz	100 0	Transverse	Pass	-56.24	233	676	26	26	158	376	

OTT

Mode:	Bandwidth (Data Rate)	Power Mode	Port/Antenna	Channel and Frequency	RB Allocation	Orientation	Frequency Response	Ambient Noise dB(A/m)	Primary Group Contiguous Pts	Secondary Group Contiguous Pts	Secondary Group Max Longitudinal	Secondary Group Max Transverse	Primary Group Contiguous Pts Margin	Secondary Group Contiguous Pts Margin	Plot Page #
LTE Band 7 QPSK ACC-ELD: 24 kbps	20 MHz	Mode A	C (ANT 3)	21100 2535 MHz	100 0	Transverse	Pass	-55.16	193	673	26	26	118	373	11 - 12
LTE Band 12 QPSK ACC-ELD: 24 kbps	10 MHz	Mode A	B (ANT 2)	23095 707.5 MHz	50 0	Transverse	Pass	-55.16	192	673	26	26	117	373	13 - 14
LTE Band 13 QPSK ACC-ELD: 24 kbps	10 MHz	Mode A	B (ANT 2)	23230 762 MHz	50 0	Transverse	Pass	-55.16	192	673	26	26	117	373	15 - 16
LTE Band 25 QPSK ACC-ELD: 24 kbps	20 MHz	Mode A	C (ANT 3)	26365 1862.5 MHz	100 0	Transverse	Pass	-55.16	193	673	26	26	118	373	17 - 18
LTE Band 26 QPSK ACC-ELD: 24 kbps	15 MHz	Mode A	B (ANT 2)	26865 831.5 MHz	75 0	Transverse	Pass	-55.16	192	673	26	26	117	373	19 - 20
LTE Band 30 QPSK ACC-ELD: 24 kbps	10 MHz	Mode A	C (ANT 3)	27710 2310 MHz	50 0	Transverse	Pass	-55.16	193	673	26	26	118	373	21 - 22
LTE Band 41 PC3 16QAM ACC-ELD: 24 kbps	20 MHz	Mode A	D (ANT 4)	40620 2593 MHz	1 0	Transverse	Pass	-55.16	130	572	26	26	55	272	23 - 24
LTE Band 41 PC2 16QAM ACC-ELD: 24 kbps	20 MHz	Mode A	D (ANT 4)	40620 2593 MHz	1 0	Transverse	Pass	-55.16	129	571	26	26	54	271	25 - 26
LTE Band 48 PC3 16QAM ACC-ELD: 24 kbps	20 MHz	Mode A	D (ANT 4)	55990 3625 MHz	1 0	Transverse	Pass	-55.16	131	572	26	26	56	272	27 - 28
LTE Band 53 PC3 16QAM ACC-ELD: 24 kbps	10 MHz	Mode A	B (ANT 2)	60197 2489.2 MHz	1 0	Transverse	Pass	-55.16	190	657	26	26	115	357	29 - 30
LTE Band 66 QPSK ACC-ELD: 24 kbps	20 MHz	Mode A	C (ANT 3)	132322 1745 MHz	100 0	Transverse	Pass	-55.16	193	673	26	26	118	373	31 - 32

5G NR (VoNR) Test Results

CMRS

Mode:	Bandwidth (MHz)	SCS (kHz)	Power Mode	Port/Antenna	Channel and Frequency	RB Allocation	Orientation	Frequency Response	Ambient Noise dB(A/m)	Primary Group Contiguous Pts	Secondary Group Contiguous Pts	Secondary Group Max Longitudinal	Secondary Group Max Transverse	Primary Group Contiguous Pts Margin	Secondary Group Contiguous Pts Margin	Plot Page #
NR Band n25 DFT-s π/2 BPSK EVS: 5.9 kbps	40 MHz	15	Mode A	C (ANT 3)	376500 1882.5 MHz	216 0	Transverse	Pass	-56.18	206	671	26	26	131	371	
NR Band n26 DFT-s π/2 BPSK EVS: 5.9 kbps	20 MHz	15	Mode A	B (ANT 2)	166300 831.5 MHz	106 0	Transverse	Pass	-56.18	201	667	26	26	126	367	
NR Band n30 DFT-s π/2 BPSK EVS: 5.9 kbps	10 MHz	15	Mode A	C (ANT 3)	462000 2310 MHz	52 0	Transverse	Pass	-56.18	198	664	26	26	123	364	
NR Band n41 PC3 DFT-s π/2 BPSK EVS: 5.9 kbps	100 MHz	30	Mode A	D (ANT 4)	518598 2592.99 MHz	1 1	Transverse	Pass	-56.18	124	557	23	26	49	257	33 - 34
NR Band n41 PC2 DFT-s π/2 BPSK EVS: 5.9 kbps	100 MHz	30	Mode A	D (ANT 4)	518598 2592.99 MHz	1 1	Transverse	Pass	-56.18	245	662	26	26	170	362	
NR Band n77 Block A PC3 DFT-s π/2 BPSK EVS: 5.9 kbps	100 MHz	30	Mode A	D (ANT 4)	633332 3500 MHz	1 1	Transverse	Pass	-56.18	238	665	26	26	163	365	

OTT

Mode:	Bandwidth (MHz)	SCS (kHz)	Power Mode	Port/Antenna	Channel and Frequency	RB Allocation	Orientation	Frequency Response	Ambient Noise dB(A/m)	Primary Group Contiguous Pts	Secondary Group Contiguous Pts	Secondary Group Max Longitudinal	Secondary Group Max Transverse	Primary Group Contiguous Pts Margin	Secondary Group Contiguous Pts Margin	Plot Page #
NR Band n25 DFT-s π/2 BPSK ACC-ELD: 23 kbps	40 MHz	15	Mode A	C (ANT 3)	376500 1882.5 MHz	216 0	Transverse	Pass	-56.25	195	673	26	26	120	373	35 - 36
NR Band n26 DFT-s π/2 BPSK ACC-ELD: 23 kbps	20 MHz	15	Mode A	B (ANT 2)	166300 831.5 MHz	106 0	Transverse	Pass	-56.25	195	673	26	26	120	373	37 - 38
NR Band n30 DFT-s π/2 BPSK ACC-ELD: 23 kbps	10 MHz	15	Mode A	C (ANT 3)	462000 2310 MHz	52 0	Transverse	Pass	-56.25	195	673	26	26	120	373	39 - 40
NR Band n41 PC3 DFT-s π/2 BPSK ACC-ELD: 23 kbps	100 MHz	30	Mode A	D (ANT 4)	518598 2592.99 MHz	1 1	Transverse	Pass	-56.25	134	578	25	26	59	278	
NR Band n41 PC2 DFT-s π/2 BPSK ACC-ELD: 23 kbps	100 MHz	30	Mode A	D (ANT 4)	518598 2592.99 MHz	1 1	Transverse	Pass	-56.25	166	618	26	26	91	318	41 - 42
NR Band n77 Block A PC3 DFT-s π/2 BPSK ACC-ELD: 23 kbps	100 MHz	30	Mode A	D (ANT 4)	633332 3500 MHz	1 1	Transverse	Pass	-56.25	190	669	26	26	115	369	43 - 44

Note(s):

The DUT supports 5G NR, Voice over New Radio (VoNR). Per the manufacturer, 5G NR (VoNR) uses the same protocol, Codec(s) and bitrates as LTE (VoLTE). Investigations were performed on LTE (VoLTE) and the worst-case Port/Antenna/Codec/Air Interface configurations from LTE (VoLTE) was used for 5G NR (VoNR) evaluations. A limited set of 5G NR (VoNR) bands were evaluated to confirm 5G NR (VoNR) compliance.

- At least one 5G NR (VoNR)-FDD LB, MB and HB were evaluated for CMRS and OTT voice services.
- At least one 5G NR (VoNR)-TDD HB and UIHB were evaluated for CMRS and OTT voice services.

Wi-Fi (VoWiFi) Test Results

CMRS

Mode:	Channel and Frequency	Data Rate	Power Mode	Antenna	Orientation	Frequency Response	Ambient Noise dB(A/m)	Primary Group Contiguous Pts	Secondary Group Contiguous Pts	Secondary Group Max Longitudinal	Secondary Group Max Transverse	Primary Group Contiguous Pts Margin	Secondary Group Contiguous Pts Margin	Plot Page #
802.11n AMR-WB: 6.6 kbps	6 2437 MHz	MCS0 6.5 Mbps	Power State 1 Mode A	ANT 3	Transverse	Pass	-56.18	267	676	26	26	192	376	
802.11ac 80 MHz AMR-WB: 6.6 kbps	42 5210 MHz	MCS0 29.3 Mbps	Power State 1 Mode A	ANT 6	Transverse	Pass	-56.18	260	669	26	26	185	369	
	58 5290 MHz	MCS0 29.3 Mbps	Power State 1 Mode A	ANT 6	Transverse	Pass	-56.18	264	676	26	26	189	376	
	106 5530 MHz	MCS0 29.3 Mbps	Power State 1 Mode A	ANT 6	Transverse	Pass	-56.18	260	675	26	26	185	375	
	155 5775 MHz	MCS0 29.3 Mbps	Power State 1 Mode A	ANT 6	Transverse	Pass	-56.18	262	675	26	26	187	375	
802.11a AMR-WB: 6.6 kbps	1 5955 MHz	BPSK 6 Mbps	Power State 1 Mode A	ANT 6	Transverse	Pass	-56.18	263	676	26	26	188	376	

OTT

Mode:	Channel and Frequency	Data Rate	Power Mode	Antenna	Orientation	Frequency Response	Ambient Noise dB(A/m)	Primary Group Contiguous Pts	Secondary Group Contiguous Pts	Secondary Group Max Longitudinal	Secondary Group Max Transverse	Primary Group Contiguous Pts Margin	Secondary Group Contiguous Pts Margin	Plot Page #
802.11n ACC-ELD: 38 kbps	6 2437 MHz	MCS0 6.5 Mbps	Power State 1 Mode A	ANT 3	Transverse	Pass	-56.25	191	668	26	26	116	368	45 - 46
802.11ac 80 MHz ACC-ELD: 38 kbps	42 5210 MHz	MCS0 29.3 Mbps	Power State 1 Mode A	ANT 6	Transverse	Pass	-56.25	194	672	26	26	119	372	47 - 48
	58 5290 MHz	MCS0 29.3 Mbps	Power State 1 Mode A	ANT 6	Transverse	Pass	-56.25	195	673	26	26	120	373	49 - 50
	106 5530 MHz	MCS0 29.3 Mbps	Power State 1 Mode A	ANT 6	Transverse	Pass	-56.25	195	673	26	26	120	373	51 - 52
	155 5775 MHz	MCS0 29.3 Mbps	Power State 1 Mode A	ANT 6	Transverse	Pass	-56.25	192	671	26	26	117	371	53 - 54
802.11a ACC-ELD: 38 kbps	1 5955 MHz	BPSK 6 Mbps	Power State 1 Mode A	ANT 6	Transverse	Pass	-56.25	194	672	26	26	119	372	55 - 56

10.1. Worst Case T-Coil Test Plot(s)

UL Verification Services Inc. SAR Lab 11

Date/Time: July 26, 2024 at 08:44

T-Coil Signal Test Report: 5G NR (DFT-s-OFDM, 1 RB, 100 MHz, QPSK, 30 kHz)

Device Under Test

Manufacturer	Model	Dimensions [mm]	Speaker Position [mm]
		146.2 x 71.8 x 7.5	144.3

Hardware Setup

Probe Name	Probe Calibration Date	DAE Name	DAE Calibration Date
AM1DV3 - 3083	January 08, 2024	DAE4 Sn1352	November 15, 2023

Communication Systems

Band Name	Communication Systems Name	Channel	Frequency [MHz]
Band n41 PC3	5G NR (DFT-s-OFDM, 1 RB, 100 MHz, QPSK, 30 kHz)	518598	2592.99

Grid Settings

Extent X [mm]	Extent Y [mm]	Step X [mm]	Step Y [mm]	Distance [mm]
52.0	52.0	4.0	4.0	10.0

Results

Audio File	Measurement Duration [s]	Margin Upper Bound [dB]	Margin Lower Bound [dB]
48k_voice_300-3000_2s.wav	2.0	2.0	2.0

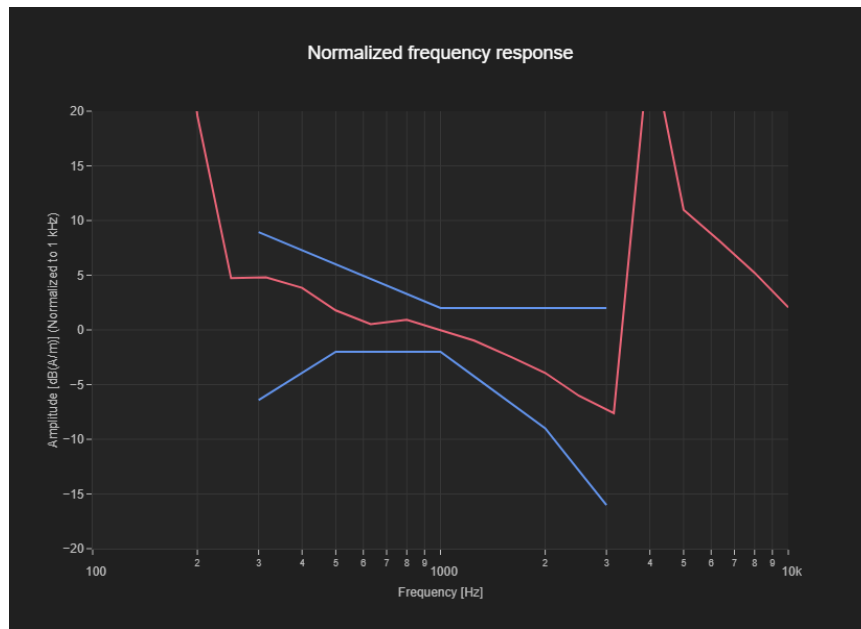

T-Coil Coupling Mode Test Report:

Results

Primary Group Contiguous Point Count	Secondary Group Point Count	Secondary Group Max Longitudinal	Secondary Group Max Transverse
124	557	23	26

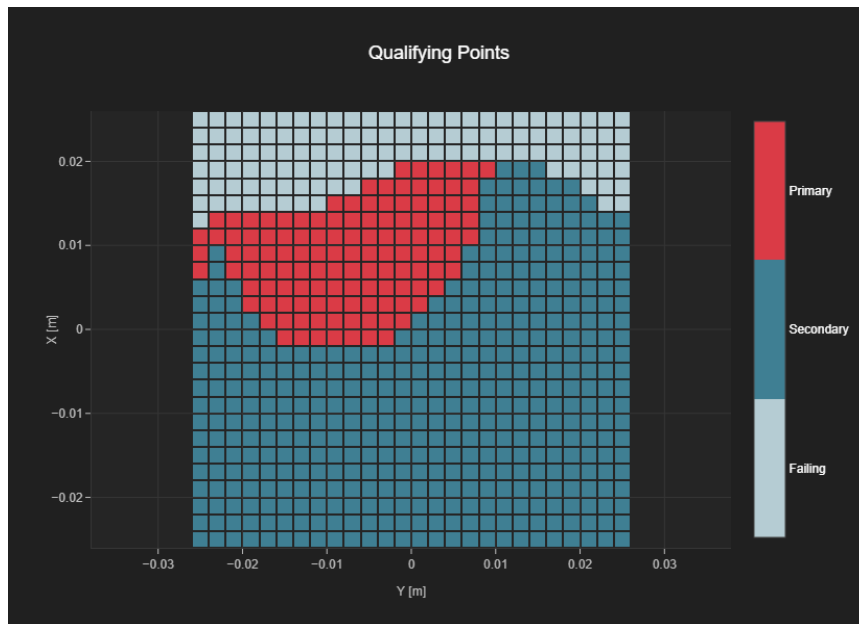

Appendix

Refer to separated files for the following appendixes.

Appendix A: T-Coil Setup Photo

Appendix B: T-Coil Test Plots

Appendix C: T-Coil Probe Certificates

END OF REPORT