



TEST REPORT

Report Number: 14523740-E4V3

Applicant : APPLE, INC.
1 APPLE PARK WAY
CUPERTINO, CA 95014, U.S.A

Model : A2848

FCC ID : BCG-E8435A

IC : 579C-E8435A

EUT Description : SMARTPHONE

Test Standard(s) : FCC 47 CFR PART 15 SUBPART C
ISED RSS-247 ISSUE 2
ISED RSS-GEN ISSUE 5 + A1 + A2

Date Of Issue:

July 27, 2023

Prepared by:

UL VERIFICATION INC.
47173 Benicia Street
Fremont, CA 94538 U.S.A.
TEL: (510) 319-4000
FAX: (510) 661-0888



REPORT REVISION HISTORY

<u>Rev.</u>	<u>Issue Date</u>	<u>Revisions</u>	<u>Revised By</u>
V1	7/17/2023	Initial Issue	Chin Pang
V2	7/20/2023	Address TCB's questions	Chin Pang
V3	7/27/2023	Address page 196-199, page 314, 315	Chin Pang

TABLE OF CONTENTS

1. ATTESTATION OF TEST RESULTS	5
2. TEST RESULTS SUMMARY	7
3. TEST METHODOLOGY	7
4. FACILITIES AND ACCREDITATION	7
5. DECISION RULES AND MEASUREMENT UNCERTAINTY	8
5.1. METROLOGICAL TRACEABILITY	8
5.2. DECISION RULES.....	8
5.3. MEASUREMENT UNCERTAINTY.....	8
5.4. SAMPLE CALCULATION	9
6. EQUIPMENT UNDER TEST.....	10
6.1. EUT DESCRIPTION	10
6.2. MAXIMUM OUTPUT POWER.....	10
6.3. DESCRIPTION OF AVAILABLE ANTENNAS	10
6.4. SOFTWARE AND FIRMWARE.....	10
6.5. WORST-CASE CONFIGURATION AND MODE.....	11
6.6. DESCRIPTION OF TEST SETUP.....	12
7. MEASUREMENT METHOD.....	16
8. TEST AND MEASUREMENT EQUIPMENT	17
9. ANTENNA PORT TEST RESULTS.....	19
9.1. ON TIME AND DUTY CYCLE.....	19
9.2. 99% BANDWIDTH.....	20
9.2.1. 802.11b MODE 1TX.....	21
9.2.2. 802.11n HT20 MODE	22
9.2.3. 802.11n HT20 CDD MODE	24
9.2.4. 802.11ax HE20 MODE	25
9.2.5. 802.11ax HE20 OFDMA MODE 2TX	29
9.3. 6dB BANDWIDTH.....	32
9.3.1. 802.11b MODE 1TX.....	33
9.3.2. 802.11ax HE20 MODE	34
9.3.3. 802.11ax HE20 OFDMA MODE 2TX	38
9.4. OUTPUT POWER.....	40
9.4.1. 802.11b MODE 1TX.....	42
9.4.2. 802.11n HT20 MODE	44
9.4.3. 802.11n HT20 CDD MODE 2TX	46
9.4.4. 802.11ax HE20 MODE	47

9.4.5.	802.11ax HE20 OFDMA MODE 2TX	55
9.5.	<i>POWER SPECTRAL DENSITY</i>	59
9.5.1.	802.11b MODE 1TX.....	60
9.5.2.	802.11n HT20 MODE	62
9.5.3.	802.11n HT20 CDD MODE 2TX	64
9.5.4.	802.11ax HE20 MODE	65
9.5.5.	802.11ax HE20 OFDMA MODE 2TX	71
9.6.	<i>CONDUCTED SPURIOUS EMISSIONS</i>	75
9.6.1.	802.11b MODE 1TX.....	76
9.6.2.	802.11n HT20 SISO MODE	80
9.6.3.	802.11n HT20 MODE 2TX.....	86
9.6.4.	802.11ax HE20 MODE	94
9.6.5.	802.11ax HE20 OFDMA MODE 2TX	112
10.	RADIATED TEST RESULTS	132
10.1.	<i>TRANSMITTER ABOVE 1 GHz</i>	134
10.1.1.	802.11b Mode 1TX ANT 4 IN THE 2.4 GHz BAND	134
10.1.2.	802.11b ANT 4, HARMONICS AND SPURIOUS EMISSIONS.....	142
10.1.3.	802.11b Mode 1TX ANT 3 IN THE 2.4 GHz BAND	148
10.1.4.	802.11b ANT 3 HARMONICS AND SPURIOUS EMISSIONS.....	156
10.1.5.	802.11n HT20 SISO MODE	162
10.1.6.	802.11n HT20 MODE CDD MODE	194
10.1.7.	802.11n 2TX HARMONICS AND SPURIOUS EMISSIONS	208
10.1.8.	802.11ax HE20 SISO MODE	214
10.1.9.	802.11ax HE20 OFDMA MODE IN THE 2.4 GHz BAND	278
10.1.10.	802.11ax 26-Tones HARMONICS AND SPURIOUS EMISSIONS	294
10.1.11.	802.11ax SU 2TX HARMONICS AND SPURIOUS EMISSIONS.....	316
10.2.	<i>WORST CASE BELOW 1 GHz</i>	322
10.3.	<i>WORST CASE 18-26 GHz</i>	324
11.	AC POWER LINE CONDUCTED EMISSIONS	326
11.1.	<i>AC POWER LINE WITH AC/DC ADAPTER</i>	327
11.2.	<i>AC POWER LINE WITH LAPTOP</i>	329
12.	SETUP PHOTOS	331

1. ATTESTATION OF TEST RESULTS

COMPANY NAME: APPLE INC.
1 APPLE PARK WAY
CUPERTINO, CA 95014, U.S.A

EUT DESCRIPTION: SMARTPHONE

MODEL: A2848

BRAND: APPLE

FCC ID: BCG-E8435A

IC: 579C-E8435A

SERIAL NUMBER: C07GQU0010S00003PJ (Conducted)
C07GTH0012C00003PJ (Conducted)
LVMPXQW46R (Radiated)

SAMPLE RECEIPT DATE: FEBRUARY 14, 2023

DATE TESTED: FEBRUARY 16 – JULY 27, 2023

APPLICABLE STANDARDS	
STANDARD	TEST RESULTS
CFR 47 Part 15 Subpart C	Complies
ISED RSS-247 Issue 2	Complies
ISED RSS-GEN Issue 5 + A1 + A2	Complies

UL Verification Inc. is tested the above equipment in accordance with the requirements set forth in the above standards. The test results show that the equipment tested is capable of demonstrating compliance with the requirements as documented in this report.

The results documented in this report apply only to the tested sample, under the conditions and modes of operation as described herein. It is the manufacturer's responsibility to assure that additional production units of this model are manufactured with identical electrical and mechanical components. All samples tested were in good operating condition throughout the entire test program. Measurement Uncertainties are published for informational purposes only and were not taken into account unless noted otherwise.

This document may not be altered or revised in any way unless done so by UL Verification Inc.. and all revisions are duly noted in the revisions section. Any alteration of this document not carried out by UL Verification Inc. will constitute fraud and shall nullify the document. This report must not be used by the client to claim product certification, approval, or endorsement by A2LA, NIST, any agency of the Federal Government, or any agency of the U.S. government.

Approved & Released For
UL Verification Inc. By:

Prepared By:



Chin Pang
Senior Lab Engineer
Consumer Technology Division
UL Verification Inc.

Tony Li
Senior Test Engineer
Consumer Technology Division
UL Verification Inc.

2. TEST RESULTS SUMMARY

FCC Clause	ISED Clause	Requirement	Result	Comment
See Comment		Duty Cycle	Reporting purposes only	ANSI C63.10 Section 11.6.
-	RSS-GEN 6.7	99% OBW	Reporting purposes only	ANSI C63.10 Section 6.9.3.
15.247 (a) (2)	RSS-247 5.2 (a)	6dB BW	Complies	None.
15.247 (b) (3)	RSS-247 5.4 (d)	Output Power (Average)	Complies	Per ANSI C63.10, Section 11.9.2.3.2..
15.247 (e)	RSS-247 5.2 (b)	PSD	Complies	None.
15.247 (d)	RSS-247 5.5	Conducted Spurious Emissions	Complies	None.
15.209, 15.205	RSS-GEN 8.9, 8.10	Radiated Emissions	Complies	None.
15.207	RSS-Gen 8.8	AC Mains Conducted Emissions	Complies	None.

3. TEST METHODOLOGY

The tests documented in this report were performed in accordance with;

- FCC CFR 47 Part 2
- FCC CFR 47 Part 15
- FCC KDB 558074 D01 v05r02 15.247 Meas Guidance
- ANSI C63.10-2013
- RSS-GEN Issue 5 + A1 + A2
- K KDB 414788 D01 Radiated Test Site v01r01-247 Issue 2

4. FACILITIES AND ACCREDITATION

UL Verification Inc. is accredited by A2LA, certification #0751.05, for all testing performed within the scope of this report. Testing was performed at the locations noted below.

	Address	ISED CABID	ISED Company Number	FCC Registration
<input type="checkbox"/>	Building 1: 47173 Benicia Street, Fremont, CA 94538, USA	US0104	2324A	550739
<input checked="" type="checkbox"/>	Building 2: 47266 Benicia Street, Fremont, CA 94538, USA			
<input checked="" type="checkbox"/>	Building 3: 843 Auburn Court, Fremont, CA 94538 USA			
<input checked="" type="checkbox"/>	Building 4: 47658 Kato Rd, Fremont, CA 94538 USA			
<input checked="" type="checkbox"/>	Building 5: 47670 Kato Rd, Fremont, CA 94538 USA			

5. DECISION RULES AND MEASUREMENT UNCERTAINTY

5.1. METROLOGICAL TRACEABILITY

All test and measuring equipment utilized to perform the tests documented in this report are calibrated on a regular basis, with a maximum time between calibrations of one year or the manufacturers' recommendation, whichever is less, and where applicable is traceable to recognized national standards.

5.2. DECISION RULES

The Decision Rule is based on Simple Acceptance in accordance with ISO Guide 98-4:2012 Clause 8.2. (Measurement uncertainty is not taken into account when stating conformity with a specified requirement.)

5.3. MEASUREMENT UNCERTAINTY

Where relevant, the following measurement uncertainty levels have been estimated for tests performed on the apparatus:

PARAMETER	U _{LAB}
Conducted Antenna Port Emission Measurement	1.94
Power Spectral Density	2.466
Time Domain Measurements Using SA	3.39
RF Power Measurement Direct Method Using Power Meter	0.450 (Peak), 1.3 (Ave)
Radio Frequency (Spectrum Analyzer)	141.16 Hz
Occupied Bandwidth	1.2%
Worst Case Conducted Disturbance, 9KHz to 0.15 MHz	3.78 dB
Worst Case Conducted Disturbance, 0.15 to 30 MHz	3.40 dB
Worst Case Radiated Disturbance, 9KHz to 30 MHz	2.87 dB
Worst Case Radiated Disturbance, 30 to 1000 MHz	6.01 dB
Worst Case Radiated Disturbance, 1000 to 18000 MHz	4.73 dB
Worst Case Radiated Disturbance, 18000 to 26000 MHz	4.51 dB

Uncertainty figures are valid to a confidence level of 95%.

5.4. SAMPLE CALCULATION

RADIATED EMISSIONS

Where relevant, the following sample calculation is provided:

Field Strength (dBuV/m) = Measured Voltage (dBuV) + Antenna Factor (dB/m) + Cable
Loss (dB) – Preamp Gain (dB)

36.5 dBuV + 18.7 dB/m + 0.6 dB – 26.9 dB = 28.9 dBuV/m

MAINS CONDUCTED EMISSIONS

Where relevant, the following sample calculation is provided:

Final Voltage (dBuV) = Measured Voltage (dBuV) + Cable Loss (dB) + Limiter Factor (dB) +
LISN Insertion Loss.

36.5 dBuV + 0 dB + 10.1 dB + 0 dB = 46.6 dBuV

6. EQUIPMENT UNDER TEST

6.1. EUT DESCRIPTION

The Apple iPhone is a smartphone with multimedia functions (music, application support, and video), cellular GSM, GPRS, EGPRS, UMTS, LTE, 5G, IEEE 802.11a/b/g/n/ac/ax, Bluetooth, Ultra-Wideband, GPS, NFC, NB UNII, 802.15.4, 802.15.4ab-NB and MSS technologies. The rechargeable battery is not user accessible.

6.2. MAXIMUM OUTPUT POWER

The transmitter has a maximum conducted output power as follows:

Frequency Range (MHz)	Mode	Output Power (dBm)	Output Power (mW)
1Tx			
2412 - 2472	802.11b	21.47	140.28
	802.11g	Covered by 802.11n HT20 1TX	
	802.11n HT20	21.48	140.60
	802.11ax HE20	21.48	140.60

2Tx			
2412 - 2472	802.11n HT20 CDD	24.48	280.54
	802.11g SDM/STBC	Covered by 802.11n HT20 2TX CDD	
	802.11ax HE20	24.45	278.61

6.3. DESCRIPTION OF AVAILABLE ANTENNAS

The antenna(s) gain and type, as provided by the manufacturer' are as follows:
 Cable loss is 1.95 dB.

Frequency Range (GHz)	ANT 4 (dBi)	ANT 3 (dBi)
2.4	-4.0	-1.5

6.4. SOFTWARE AND FIRMWARE

The EUT firmware installed during testing was 23_10_663

6.5. WORST-CASE CONFIGURATION AND MODE

EUT was investigated in three orthogonal orientations X (Flatbed), Y (Landscape) and Z (Portrait) on ANT 4, ANT 3, and 2TX. It was determined that X (Flatbed) orientation was worst-case orientation for ANT 3 and Y (Landscape) orientation was the worst-case orientation for ANT4 and 2TX.

With same power on Full RU and SU higher data rate, investigation were performed on both bandedge to determine the worst case, and SU mode was determined to be the worst case.

Radiated band edge, harmonic, and spurious emissions from 1GHz to 18GHz were performed with the EUT set to transmit at highest power on Low/Middle/High channels.

Radiated emissions below 1GHz, 18-26GHz and power line conducted emissions were performed with the EUT transmits at the channel with the highest output power as worst-case scenario. There were no emissions found below 30MHz within 20dB of the limit.

For radiated harmonics spurious below 1GHz, 1-18GHz L/M/H channels, 18-26GHz, and power line conducted emissions were performed with the EUT set at the 2TX CDD mode among the CDD/SDM modes and 2TX HE mode with power setting equal or higher than SISO modes as worst-case scenario. G mode covered by HT20 mode since it has the same power as HT20.

Below 1GHz tests were performed with EUT connected to AC power adapter as the worst case; and for above 1GHz tests, the worst-case configuration reported was with EUT only. For AC line conducted emission, test was investigated with AC power adapter and with laptop.

The output power and psd for the 802.11 ax mode were investigated between all different tones, and we found that SU mode had the highest output power and the lowest tone had the highest PSD readings. And after investigation, antenna port conducted tests were performed on both SU and lowest tones; radiated spurious emission and radiated band edge tests were performed on SU and lowest tones.

Low data rate was used to test on antenna port conducted tests and radiated spurious emissions since it has the highest maximum power. For radiated bandedge, following are the worst-case data rates set for test:

802.11b mode: 1 Mbps
802.11n HT20mode: MCS7
802.11ax HE20mode: MCS9
802.11ax HE20 RU26 and SU, MCS9

Note: In the Radiated Plots and emissions data, ANT0=ANT4 and ANT1=ANT 3.

6.6. DESCRIPTION OF TEST SETUP

SUPPORT TEST EQUIPMENT						
Description	Manufacturer	Model	Serial Number	FCC ID/ DoC		
Laptop	Apple	Macbook Pro	C02VD7SAHV22	BCGA1708		
Laptop AC/DC adapter	Liteon Technology	A1424	NSW25679	DoC		
EUT AC/DC adapter	Apple	A1720	C3D8417A7R93KVPA8	DoC		
Conducted Switch Box	UL	n/a	208281	N/A		
10dB Fixed Attenuator, 2 Watts Up to 26.5 GHz	Pasternack Enterprises	PE7024-10	236358	N/A		
I/O CABLES (RF CONDUCTED TEST)						
Cable No.	Port	# of Identical Ports	Connector Type	Cable Type	Cable Length (m)	Remarks
1	SMA	1	SMA	Shielded	0.75	To spectrum Analyzer
2	Antenna	2	SMA	Un-shielded	0.2	To Conducted Switch Box
3	USB-C	1	USB-C	Shielded	1.0	N/A
4	AC	1	AC	Un-shielded	2	N/A
I/O CABLES (RF RADIATED AND AC LINE CONDUCTED TEST)						
Cable No.	Port	# of Identical Ports	Connector Type	Cable Type	Cable Length (m)	Remarks
1	AC	1	AC	Un-shielded	2	N/A
2	USB	1	USB	Shielded	1	N/A

TEST SETUP

The EUT setup is shown as below. Test software exercised the radio card.

SETUP DIAGRAM FOR CONDUCTED TESTS

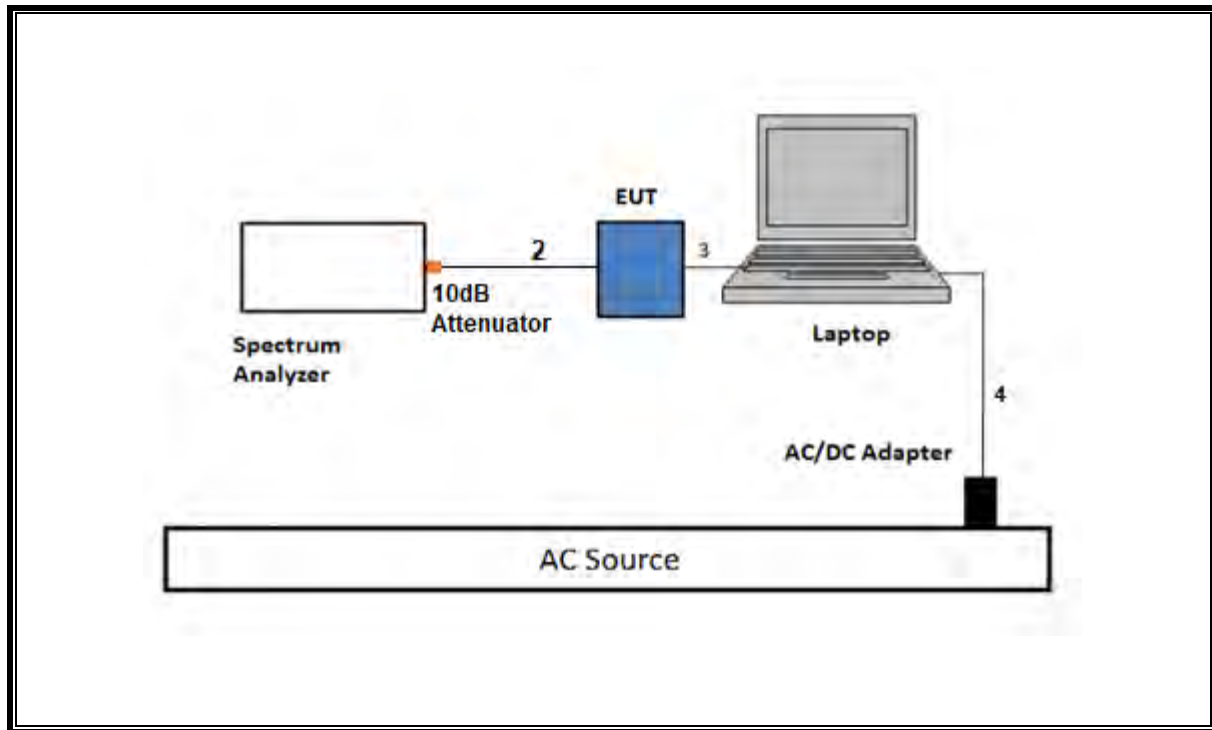
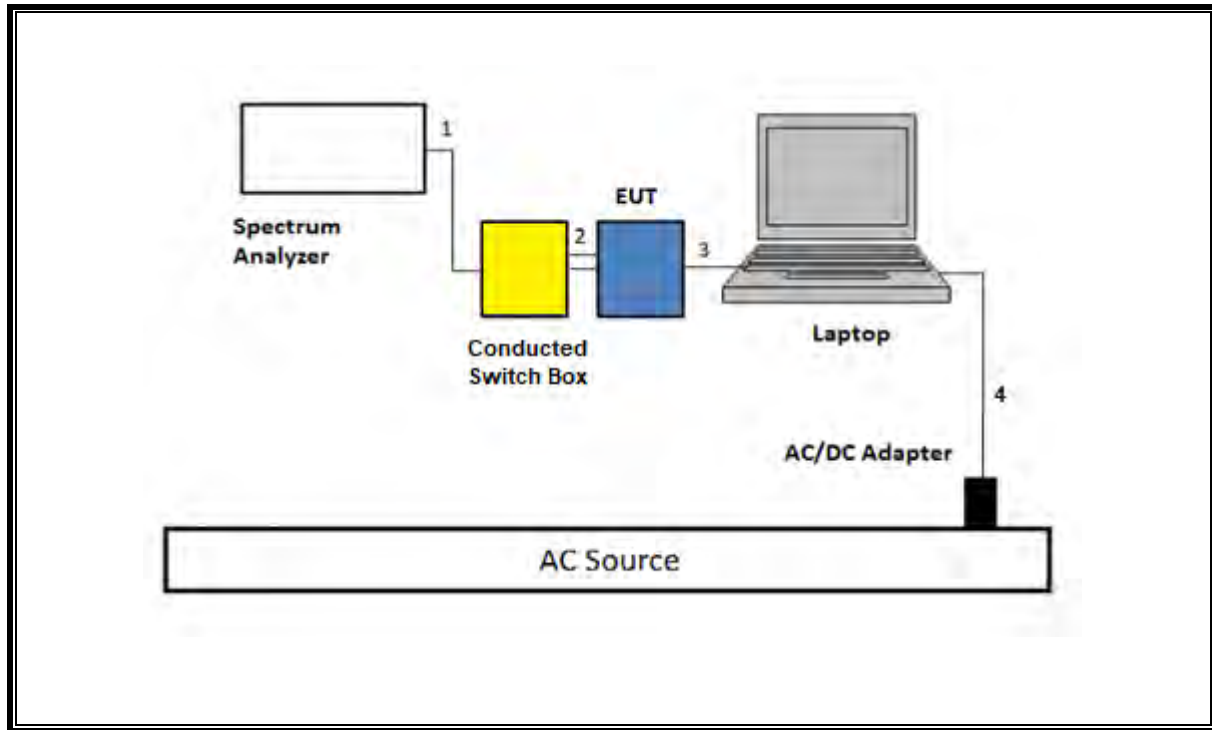

SETUP DIAGRAM FOR RADIATED TESTS Above 1 GHz

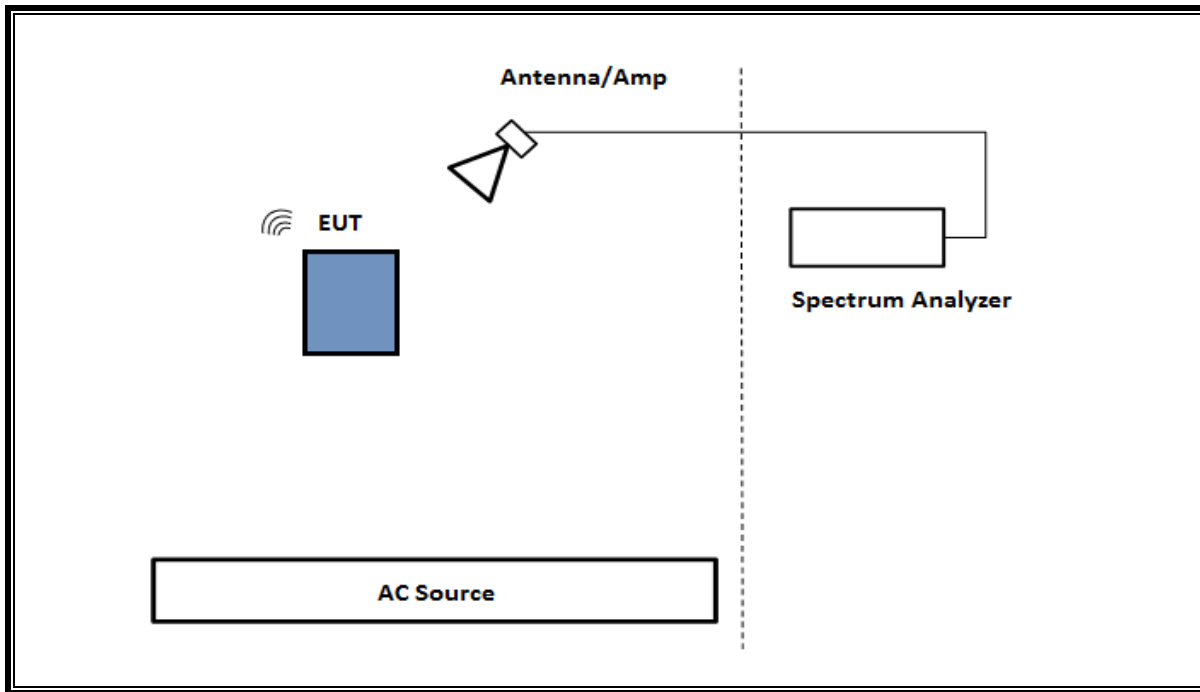

SETUP DIAGRAM FOR Below 1GHz and AC LINE CONDUCTED TEST

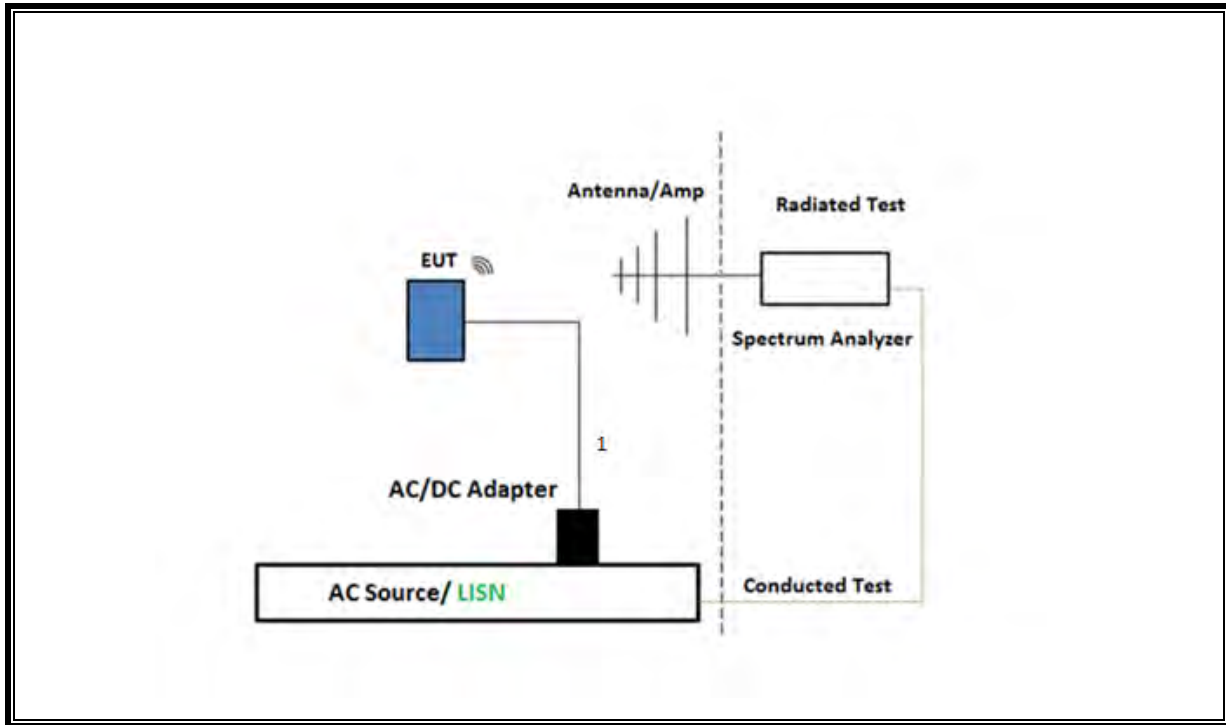

TEST SETUP- AC LINE CONDUCTED: LAPTOP CONFIGURATION

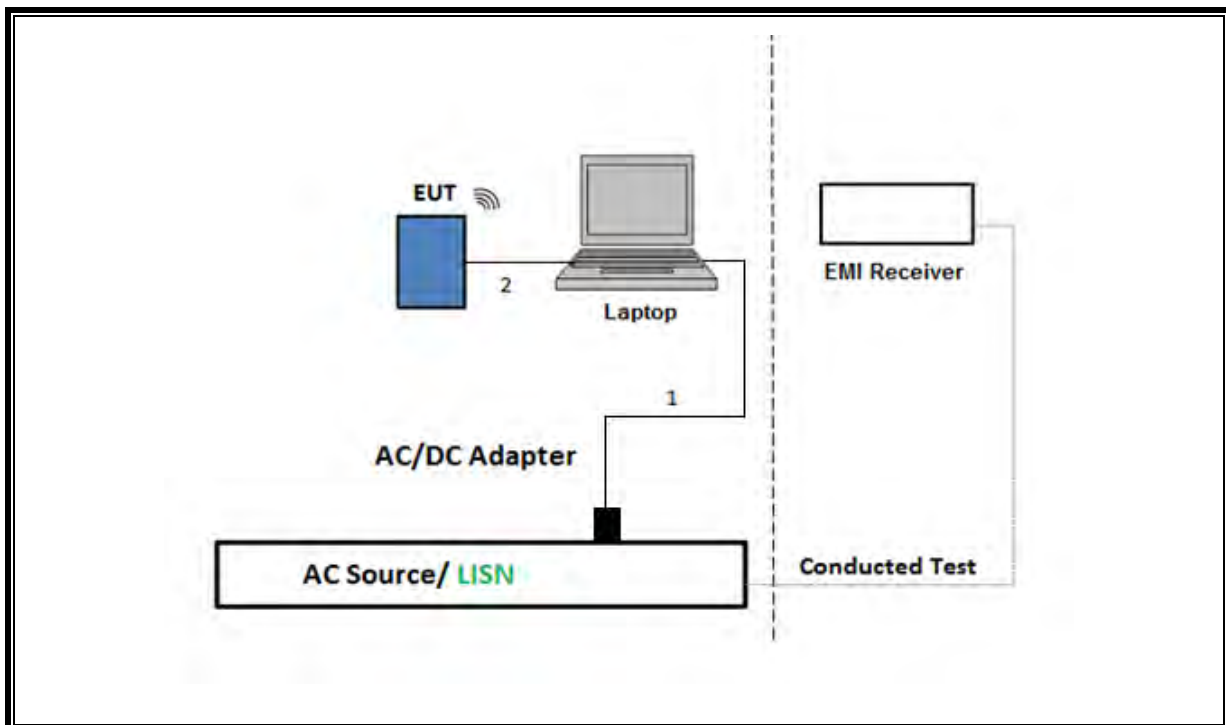

7. MEASUREMENT METHOD

Test Item	Test Method
6 dB BW	ANSI C63.10 Subclause -11.8.1 RBW \geq DTS BW
99% BW	ANSI C63.10-2013, Subclause 6.9.3.
Output Power	ANSI C63.10 Subclause -11.9.2.3.2 Method AVGPM G (Measurement using an RF average-reading power meter)
PSD	ANSI C63.10 Subclause -11.10.3 Method AVGPSD-1
Radiated emissions non-restricted frequency bands	ANSI C63.10 Subclause -11.11 & Clause 13
Radiated emissions restricted frequency bands	ANSI C63.10 Subclause -11.12.1 & Clause 13
Conducted emissions in restricted frequency bands	ANSI C63.10 Subclause -11.12.2
Band-edge	ANSI C63.10 Subclause -11.13.3.2 & Clause 13: Integration method -Peak detection
Band-edge	ANSI C63.10 Subclause -11.13.3.3 & Clause 13: Integration method -Trace averaging with continuous transmission at full power
Radiated Spurious Emissions Below 30MHz	ANSI C63.10-2013 Subclause 6.4 & Clause 13
AC Power Line Conducted Emissions	ANSI C63.10-2013, Subclause 6.2

8. TEST AND MEASUREMENT EQUIPMENT

The following test and measurement equipment was utilized for the tests documented in this report:

TEST EQUIPMENT LIST					
Description	Manufacturer	Model	ID Num	Cal Due	Last Cal
*Antenna, Horn 1-18GHz	ETS Lindgren	3117	80707	04/28/2023	04/28/2022
*RF Filter Box	UL-FR1	NA	173233	03/28/2023	03/28/2022
EMI Test Receiver	Rohde & Schwarz	ESW44	191429	02/29/2024	02/29/2023
RF Filter Box 1-18GHz	UL-FR13528	NA	173528	12/22/2023	12/22/2022
*Antenna, Horn 1-18GHz	ETS Lindgren	3117	200786	02/24/2023	02/24/2022
*EMI Test Receiver	Rohde & Schwarz	ESW44	191428	02/20/2023	02/20/2022
Antenna, Broadband Hybrid,	Sunol Sciences Corp.	JB3	80706	07/28/2023	07/28/2022
Amplifier, 9KHz to 1GHz, 32dB	SONOMA INSTRUMENT	310	204041	08/24/2023	08/24/2022
*Antenna Horn, 18 to 26.5GHz	ARA	MWH-1826/B	172353	06/01/2023	06/01/2022
Amplifier 18-26.5GHz, +5Vdc, 60dB min	AMPLICAL	AMP18G26.5-60	171583	02/29/2024	02/29/2023
Antenna, Passive Loop 30Hz to 1MHz	Electro-Metrics	EM-6871	170013	07/28/2023	07/28/2022
Antenna, Passive Loop 100KHz to 30MHz	ETS-Lindgren	EM-6872	170015	07/28/2023	07/28/2022
Amplifier, 9KHz to 1GHz, 32dB	SONOMA INSTRUMENT	310	204041	08/24/2023	08/24/2022
Spectrum Analyzer, PSA, 3Hz to 26.5GHz	Keysight Technologies Inc	E4440A	81311	02/29/2024	02/29/2023
Spectrum Analyzer, PXA, 3Hz to 44GHz	Keysight Technologies Inc	N9030A	85214	02/28/2024	02/28/2023
*Antenna, Horn 1-18GHz	ETS Lindgren	3117	200786	02/24/2023	02/24/2022
Antenna, Horn 1-18GHz	ETS Lindgren	3117	230300	01/12/2024	01/12/2023
Filter Box, 1-18GHz 12 Port	UL-FR1	Frankenstein	216812	09/17/2023	09/17/2022
EMI Receiver	Rohde & Schwarz	ESW44	235670	04/30/2024	04/30/2023
Antenna, Horn 1-18GHz	ETS Lindgren	3117	226672	01/09/2024	01/09/2023
RF Filter Box, 1-18GHz, 17 Ports	UL-FR1	RATS 2	226781	04/30/2024	04/30/2023
RF Filter Box, 1-18GHz	UL-FR1	NA	171875	11/10/2023	11/10/2022
Antenna, Horn 1-18GHz	ETS Lindgren	3117	206807	02/28/2024	02/28/2023
EMI Receiver	Rohde & Schwarz	ESW44	201502	02/29/2024	02/29/2023
Antenna, Horn 1-18GHz	ETS Lindgren	3117	226671	01/09/2024	01/09/2023
Filter Box, 1-18GHz 12 Port	UL-FR1	Frankenstein	217255	08/23/2023	08/23/2022
RF Filter Box, 1-18GHz, 12 Port.	UL-FR1	Frankenstein	231874	04/19/2024	04/19/2023
Antenna, Horn 1-18GHz	ETS-Lindgren	3117	84796	09/19/2023	09/19/2022
RF Filter Box 1-18GHz	UL-FR1	SAC 12 port rf box	217521	10/09/2023	10/09/2022
EMI Receiver	Rohde & Schwarz	ESW44	201498	02/29/2024	02/29/2023
Spectrum Analyzer, PXA, 3Hz to 44GHz	Keysight Technologies Inc	N9030A-544	87738	02/28/2024	02/28/2023
*Conducted Switch Box	N/A	CSB	221008	06/21/2023	06/21/2022
10dB Fixed Attenuator, 2 Watts Up to 26.5 GHz	Pasternack Enterprises	PE7024-10	236358	Verified/Characterized before use	
10dB Fixed Attenuator, 2 Watts Up to 26.5 GHz	Pasternack Enterprises	PE7024-10	236355	Verified/Characterized before use	
Power Meter, P-series single channel	Keysight Technologies Inc	N1911A	90756	01/31/2024	01/31/2023
Power Sensor, P - series, 50MHz to 18GHz, Wideband	Keysight Technologies Inc	N1921A	90389	01/31/2024	01/31/2023

TEST EQUIPMENT LIST					
Description	Manufacturer	Model	ID Num	Cal Due	Last Cal
*Antenna, Horn 1-18GHz	ETS Lindgren	3117	84797	09/20/2023	09/20/2022
*RF Filter Box	UL-FR1	NA	173233	09/20/2023	09/20/2022
RF Filter Box 1-18GHz	UL-FR	NA	206359	08/13/2023	08/13/2022
Antenna, Horn 1-18GHz	ETS Lindgren	3117	222740	08/31/2023	08/31/2022
RF Filter Box	UL-FR1	N/A	172938	08/16/2023	08/16/2022
EMI TEST RECEIVER	Rohde & Schwarz	ESW44	170063	02/29/2024	02/29/2023

AC Line Conducted					
Description	Manufacturer	Model	ID Num	Cal Due	Last Cal
EMI Test Receiver 9kHz-7GHz	Rohde & Schwarz	ESR	93091	02/29/2024	02/29/2023
LISN for Conducted Emissions CISPR-16	FISCHER CUSTOM COMMUNICATIONS	FCC-LISN-50/250- 25-2-01-480V	175764	01/31/2024	01/31/2023
Transient Limiter	TE	TBFL1	207996	07/15/2023	07/15/2022
UL AUTOMATION SOFTWARE					
Radiated Software	UL	UL EMC	Ver 9.5, May 1 , 2023		
Conducted Software	UL	UL EMC	2020.8.16		
AC Line Conducted Software	UL	UL EMC	Ver 9.5, Mar 3, 2023		

*Testing is completed before equipment expiration date.

9. ANTENNA PORT TEST RESULTS

9.1. ON TIME AND DUTY CYCLE

LIMITS

None; for reporting purposes only.

PROCEDURE

KDB 558074 Zero-Span Spectrum Analyzer Method.

Test Engineer:	26118
Test Date:	6/15/2023

ON TIME AND DUTY CYCLE RESULTS

Mode	ON Time B (msec)	Period (msec)	Duty Cycle x (linear)	Duty Cycle (%)	Duty Cycle Correction Factor (dB)	1/B Minimum VBW (kHz)
2.4GHz Band						
802.11b	12.410	12.430	0.998	99.84%	0.00	0.010
802.11n HT20 MCS0	1.919	1.940	0.989	98.92%	0.00	0.010
802.11n HT20 MCS7	0.411	0.433	0.9490	94.90%	0.23	2.434
802.11ax HE20 RU26 MCS0	1.487	1.508	0.986	98.61%	0.00	0.010
802.11ax HE20 RU26 MCS9	0.350	0.393	0.892	89.15%	0.50	2.856
802.11ax HE20 SU MCS0	1.489	1.508	0.987	98.72%	0.00	0.010
802.11ax HE20 SU MCS9	0.168	0.188	0.892	89.20%	0.50	5.967

Note: Duty cycle 2TX is the same as 1TX.

DUTY CYCLE PLOTS

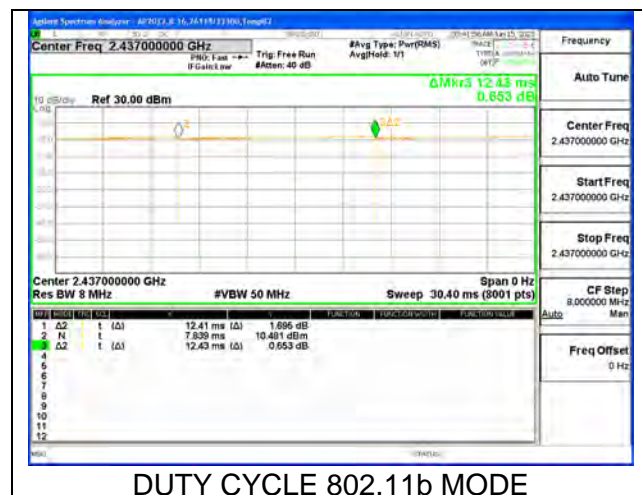

9.2. 99% BANDWIDTH

LIMITS

None; for reporting purposes only.

RESULTS

Only Mid channel plot is reported to show setting parameter complies with testing method/procedure.

9.2.1. 802.11b MODE 1TX

1TX ANT 4 MODE

Channel	Frequency (MHz)	99% Bandwidth (MHz)
Low 1	2412	12.914
Mid 6	2437	12.972
High 11	2462	13.009
High 12	2467	12.882
High 13	2472	13.033

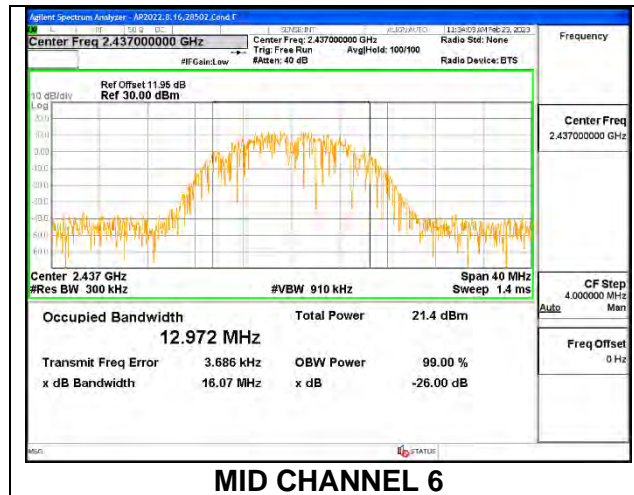

1TX ANT 3 MODE

Channel	Frequency (MHz)	99% Bandwidth (MHz)
Low 1	2412	13.132
Mid 6	2437	12.936
High 11	2462	12.883
High 12	2467	12.952
High 13	2472	13.041

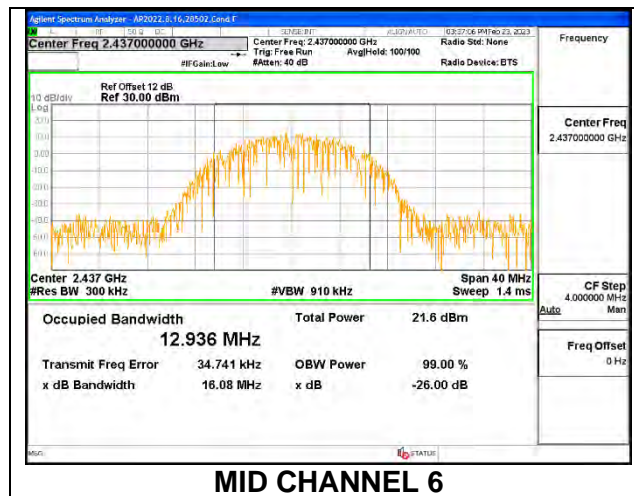

9.2.2. 802.11n HT20 MODE

1TX ANT 4 MODE

Channel	Frequency (MHz)	99% Bandwidth (MHz)
Low 1	2412	17.603
Low 2	2417	17.702
Low 3	2422	17.652
Mid 6	2437	17.673
High 9	2452	17.504
High 10	2457	17.509
High 11	2462	17.601
High 12	2467	17.748
High 13	2472	17.757

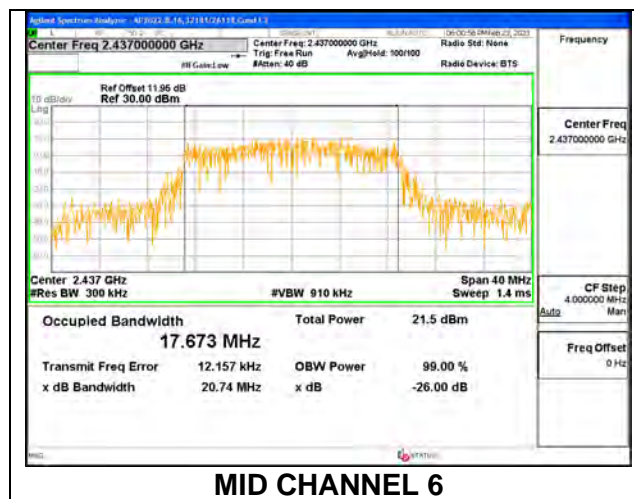

1TX ANT 3 MODE

Channel	Frequency (MHz)	99% Bandwidth (MHz)
Low 1	2412	17.746
Low 2	2417	17.739
Low 3	2422	17.724
Mid 6	2437	17.804
High 9	2452	17.805
High 10	2457	17.724
High 11	2462	17.737
High 12	2467	17.719
High 13	2472	17.876

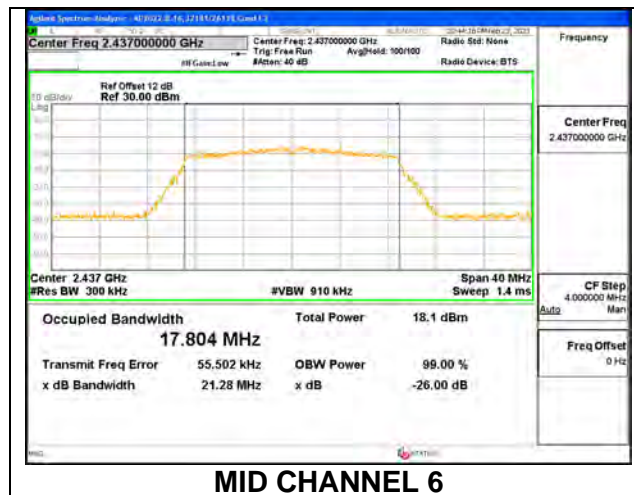

MID CHANNEL 6

9.2.3. 802.11n HT20 CDD MODE

ANT 4 + ANT 3 2TX MODE

Channel	Frequency (MHz)	99% Bandwidth (MHz) ANT 4 (Ant1)	99% Bandwidth (MHz) ANT 3 (Ant2)
Low 1	2412	17.753	17.735
Low 2	2417	17.728	17.688
Low 3	2422	17.733	17.717
Low 4	2427	17.726	17.731
Mid 6	2437	17.728	17.732
High 8	2447	17.793	17.715
High 9	2452	17.781	17.755
High 10	2457	17.765	17.687
High 11	2462	17.794	17.724
High 12	2467	17.698	17.627
High 13	2472	17.771	17.776

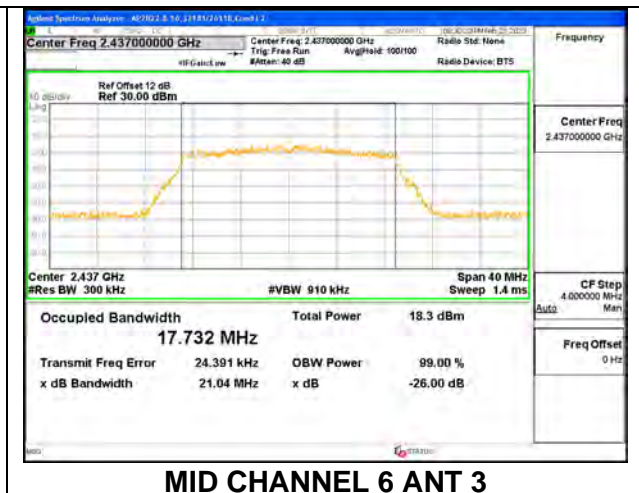
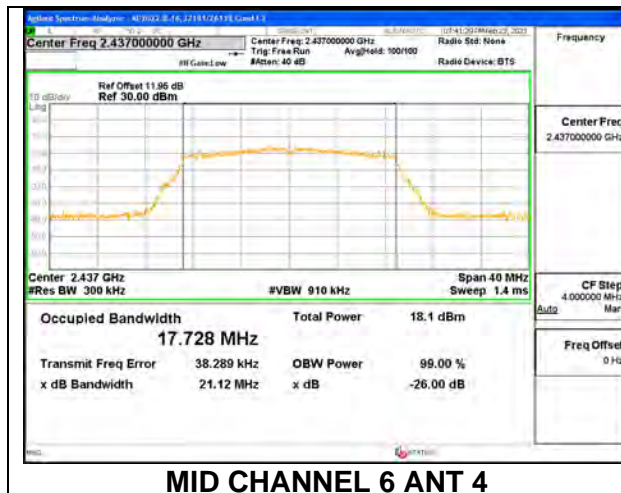

9.2.4. 802.11ax HE20 MODE

ANT 4 SISO MODE: 26-Tones, RU index 0

Channel	Frequency (MHz)	99% Bandwidth (MHz)
Low 1	2412	18.379
Mid 6	2437	17.889
High 11	2462	18.177
High 12	2467	18.215
High 13	2472	18.247

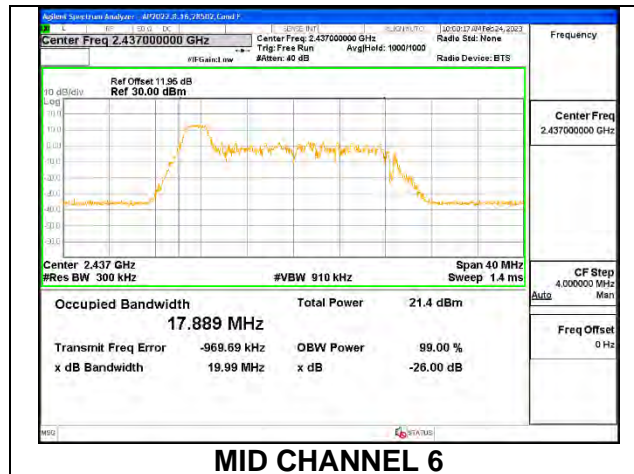

ANT 4 SISO MODE: 26-Tones, RU Index 4

Channel	Frequency (MHz)	99% Bandwidth (MHz)
Low 1	2412	16.826
Mid 6	2437	16.577
High 11	2462	16.898
High 12	2467	16.577
High 13	2472	16.823

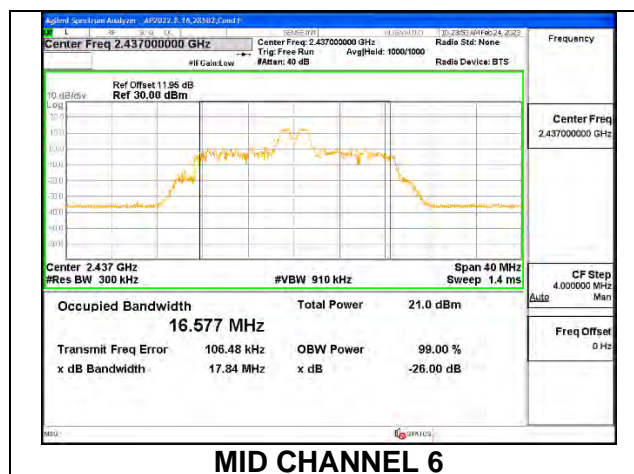

ANT 4 SISO MODE: 26-Tones, RU Index 8

Channel	Frequency (MHz)	99% Bandwidth (MHz)
Low 1	2412	18.485
Mid 6	2437	18.540
High 11	2462	17.953
High 12	2467	18.569
High 13	2472	18.625

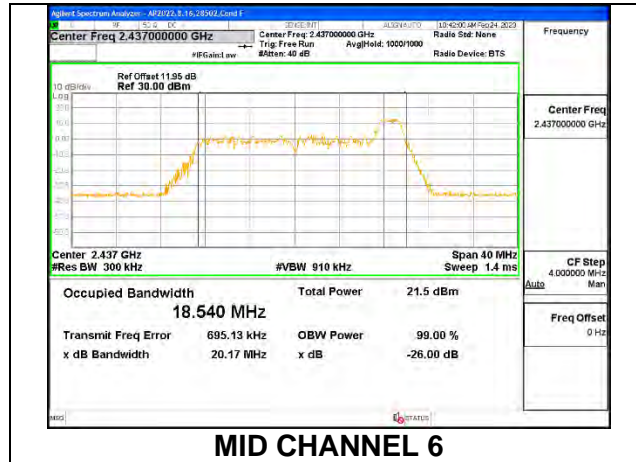

ANT 4 SISO MODE: SU Mode

Channel	Frequency (MHz)	99% Bandwidth (MHz)
Low 1	2412	19.026
Low 2	2417	19.011
Low 3	2422	19.048
Mid 6	2437	19.054
High 9	2452	19.018
High 10	2457	18.990
High 11	2462	19.014
High 12	2467	19.031
High 13	2472	18.991

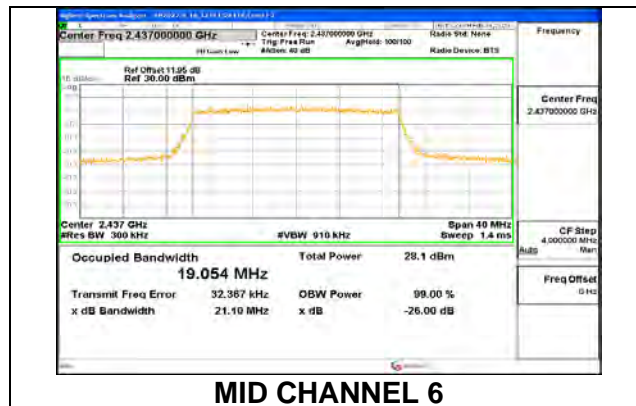

ANT 3 SISO MODE: 26-Tones, RU Index 0

Channel	Frequency (MHz)	99% Bandwidth (MHz)
Low 1	2412	18.417
Mid 6	2437	18.390
High 11	2462	18.252
High 12	2467	18.190
High 13	2472	18.059

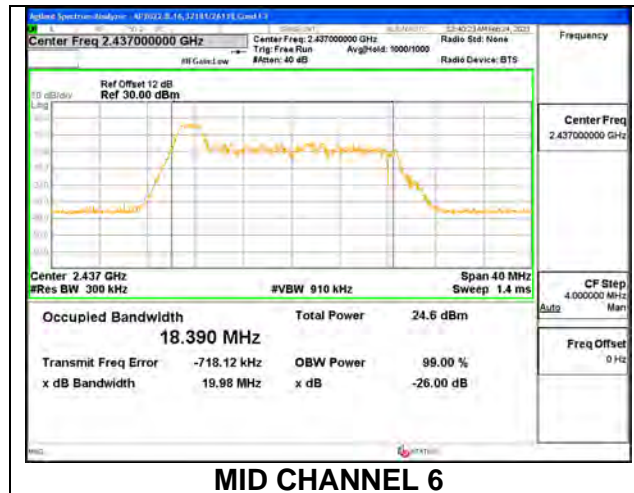

ANT 3 SISO MODE: 26-Tones, RU Index 4

Channel	Frequency (MHz)	99% Bandwidth (MHz)
Low 1	2412	16.600
Mid 6	2437	16.675
High 11	2462	16.778
High 12	2467	16.870
High 13	2472	16.774

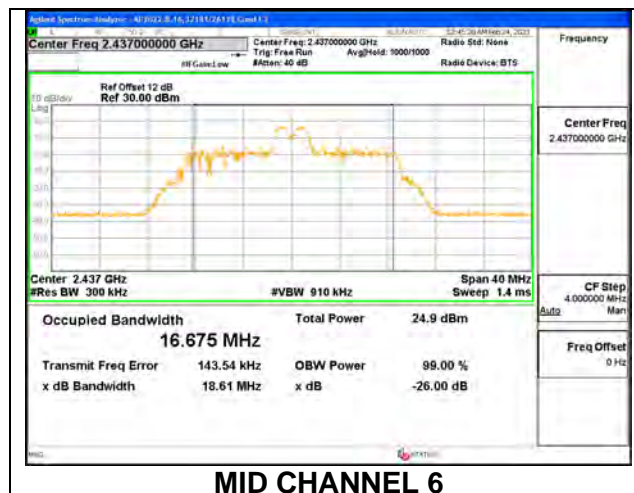

ANT 3 SISO MODE: 26-Tones, RU Index 8

Channel	Frequency (MHz)	99% Bandwidth (MHz)
Low 1	2412	18.202
Mid 6	2437	18.493
High 11	2462	18.523
High 12	2467	18.534
High 13	2472	18.621

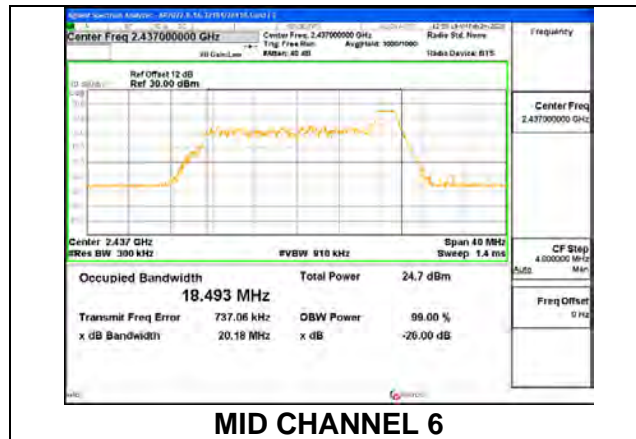

ANT 3 SISO MODE: SU Mode

Channel	Frequency (MHz)	99% Bandwidth (MHz)
Low 1	2412	18.960
Low 2	2417	18.953
Low 3	2422	18.981
Mid 6	2437	19.073
High 9	2452	19.025
High 10	2457	18.967
High 11	2462	18.955
High 12	2467	18.997
High 13	2472	18.979

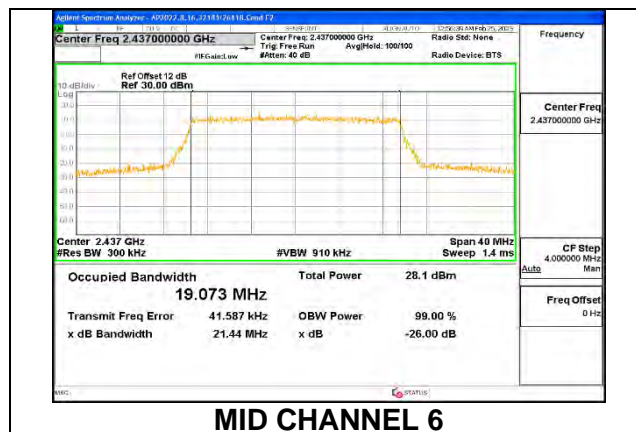

9.2.5. 802.11ax HE20 OFDMA MODE 2TX

ANT 4 + ANT 3 2TX MODE: 26-Tones, RU Index 0

Channel	Frequency (MHz)	99% Bandwidth (MHz)	99% Bandwidth (MHz)
		ANT 4	ANT 3
Low 1	2412	18.409	18.369
Mid 6	2437	18.314	18.336
High 11	2462	18.195	18.127
High 12	2467	18.252	18.034
High 13	2472	18.253	18.080

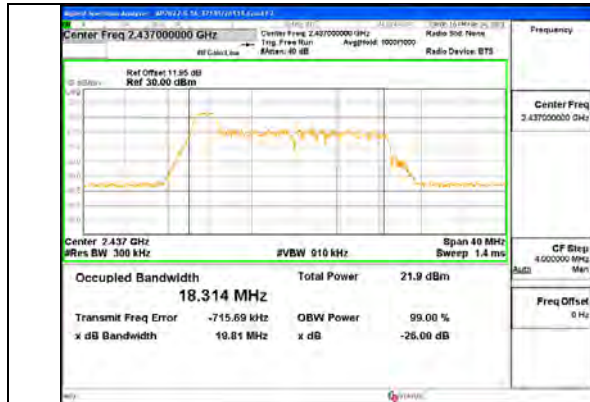

MID CHANNEL 6 ANT 4

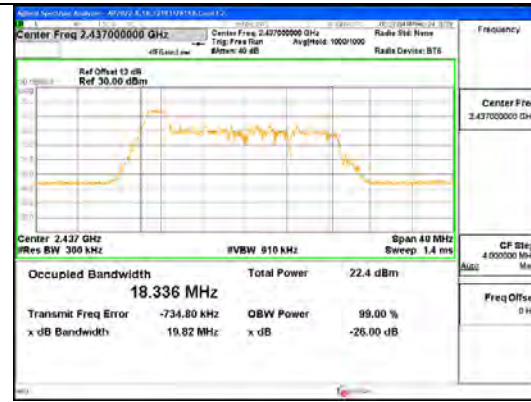

MID CHANNEL 6 ANT 3

ANT 4 + ANT 3 2TX MODE: 26-Tones, RU Index 4

Channel	Frequency (MHz)	99% Bandwidth (MHz)	99% Bandwidth (MHz)
		ANT 4	ANT 3
Low 1	2412	18.531	16.603
Mid 6	2437	16.872	16.737
High 11	2462	16.839	16.456
High 12	2467	16.864	16.461
High 13	2472	16.733	16.504

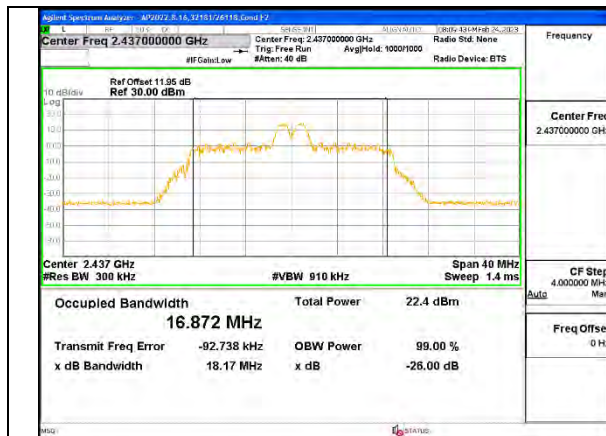

MID CHANNEL 6 ANT 4

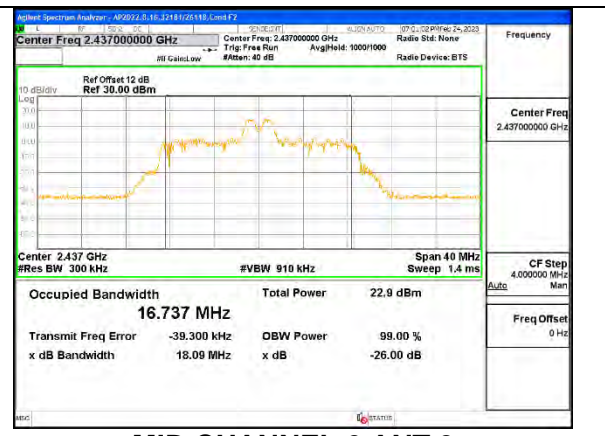

MID CHANNEL 6 ANT 3

ANT 4 + ANT 3 2TX MODE: 26-Tones, RU Index 8

Channel	Frequency (MHz)	99% Bandwidth (MHz) ANT 4	99% Bandwidth (MHz) ANT 3
Low 1	2412	18.435	17.991
Mid 6	2437	18.276	18.415
High 11	2462	18.596	18.458
High 12	2467	18.539	18.369
High 13	2472	18.519	18.484

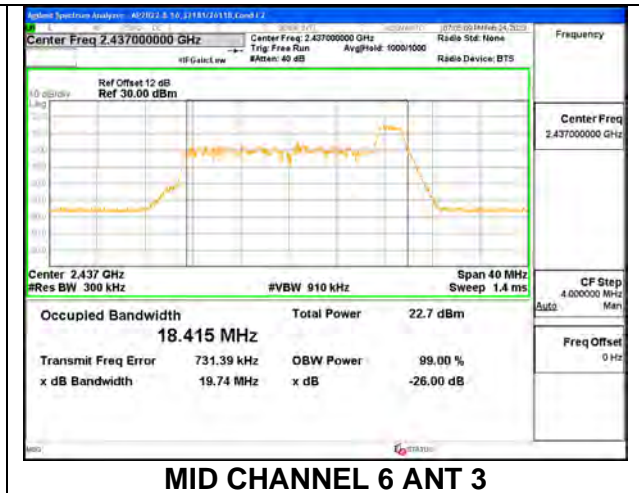
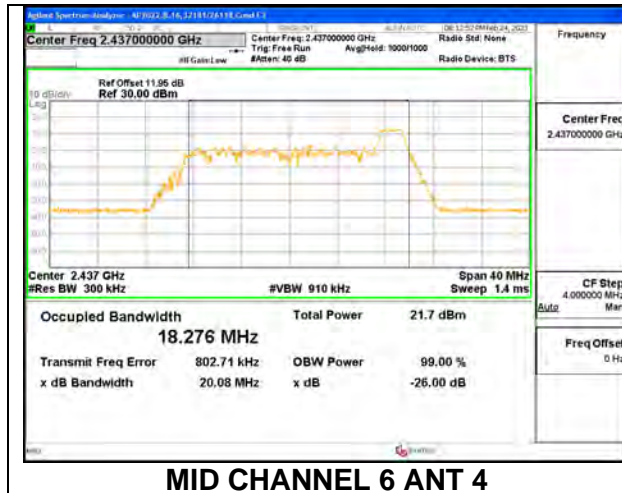

ANT 4 + ANT 3 2TX MODE: SU Mode

Channel	Frequency (MHz)	99% Bandwidth (MHz)	99% Bandwidth (MHz)
		ANT 4	ANT 3
Low 1	2412	19.008	18.950
Low 2	2417	19.054	18.983
Low 3	2422	19.000	18.982
Low 4	2427	19.017	19.029
Mid 6	2437	19.029	19.017
High 8	2447	19.022	19.036
High 9	2452	19.004	19.017
High 10	2457	18.974	18.929
High 11	2462	19.034	18.948
High 12	2467	19.034	19.002
High 13	2472	18.975	18.953

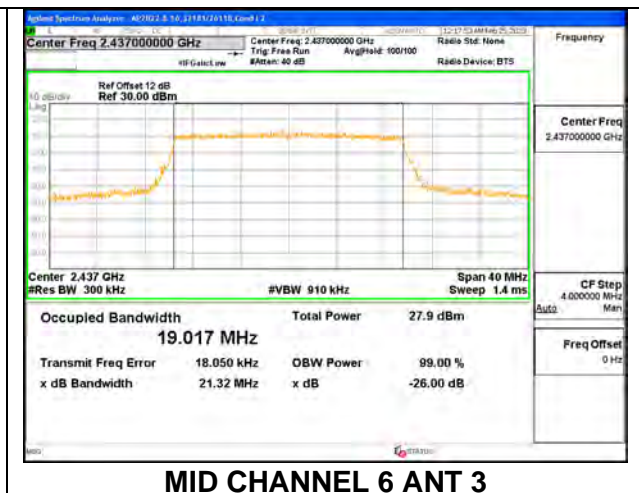
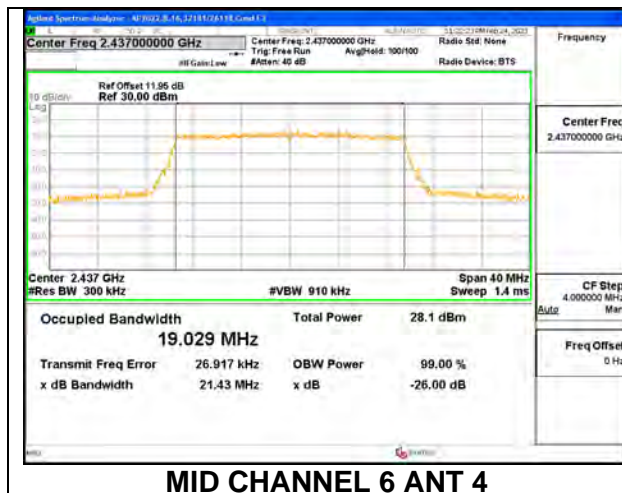

9.3. 6dB BANDWIDTH

LIMITS

FCC §15.247 (a) (2)

RSS-247 5.2 (a)

The minimum 6 dB bandwidth shall be at least 500 kHz.

RESULTS

The 6dB bandwidth was measured for the narrowest bandwidth mode, b Mode and ax HE20 Mode 26-Tones as worst case to demonstrate compliance with the minimum required bandwidth of 500 kHz to cover all OFDMA modes.

Only Mid channel plot is reported to show setting parameter complies with testing method/procedure.

9.3.1. 802.11b MODE 1TX

1TX ANT 4 MODE

Channel	Frequency (MHz)	6dB Bandwidth (MHz)	Minimum Limit (MHz)
Low 1	2412	7.60	0.5
Mid 6	2437	7.20	0.5
High 11	2462	7.44	0.5
High 12	2467	7.96	0.5
High 13	2472	7.28	0.5

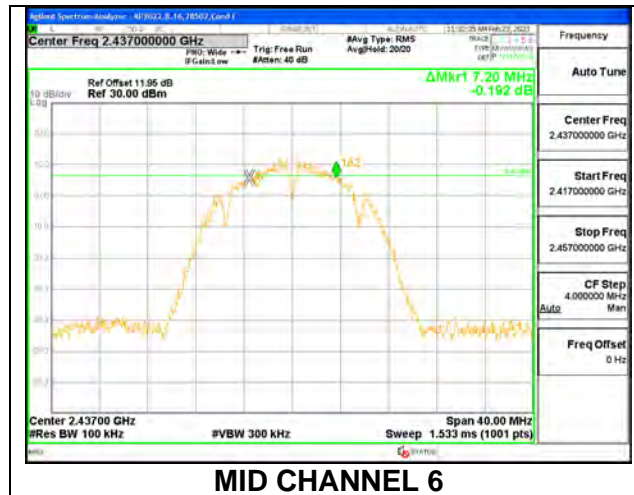

MID CHANNEL 6

1TX ANT 3 MODE

Channel	Frequency (MHz)	6dB Bandwidth (MHz)	Minimum Limit (MHz)
Low 1	2412	7.12	0.5
Mid 6	2437	7.68	0.5
High 11	2462	7.64	0.5
High 12	2467	7.68	0.5
High 13	2472	7.68	0.5

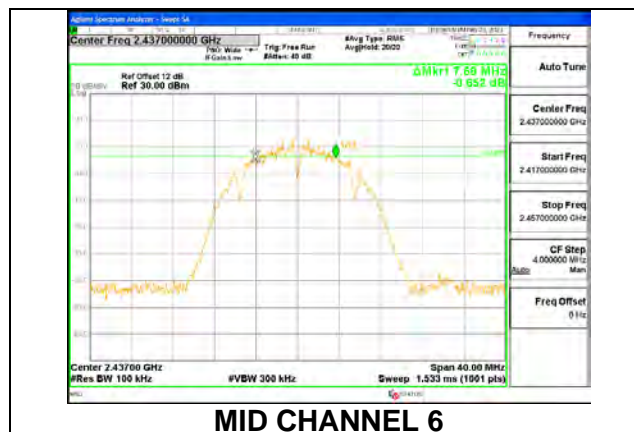

MID CHANNEL 6

9.3.2. 802.11ax HE20 MODE

ANT 4 SISO MODE: 26-Tones, RU index 0

Channel	Frequency (MHz)	6dB Bandwidth (MHz)	Minimum Limit (MHz)
Low 1	2412	2.12	0.5
Mid 6	2437	2.16	0.5
High 11	2462	2.16	0.5
High 12	2467	2.08	0.5
High 13	2472	2.16	0.5

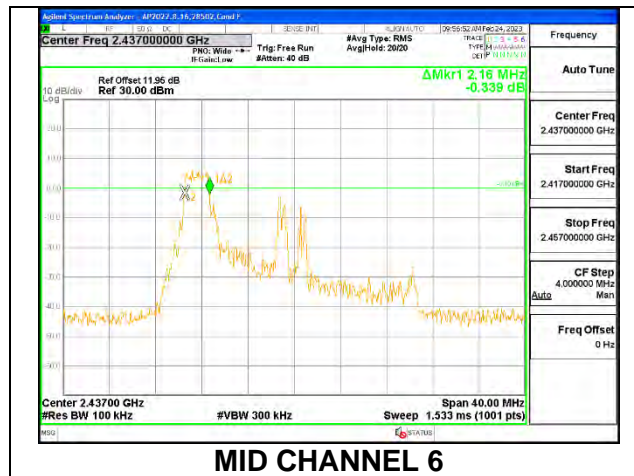

MID CHANNEL 6

ANT 4 SISO MODE: 26-Tones, RU Index 4

Channel	Frequency (MHz)	6dB Bandwidth (MHz)	Minimum Limit (MHz)
Low 1	2412	2.64	0.5
Mid 6	2437	2.64	0.5
High 11	2462	2.68	0.5
High 12	2467	2.68	0.5
High 13	2472	2.64	0.5



MID CHANNEL 6

ANT 4 SISO MODE: 26-Tones, RU Index 8

Channel	Frequency (MHz)	6dB Bandwidth (MHz)	Minimum Limit (MHz)
Low 1	2412	2.12	0.5
Mid 6	2437	2.04	0.5
High 11	2462	2.12	0.5
High 12	2467	2.20	0.5
High 13	2472	2.08	0.5

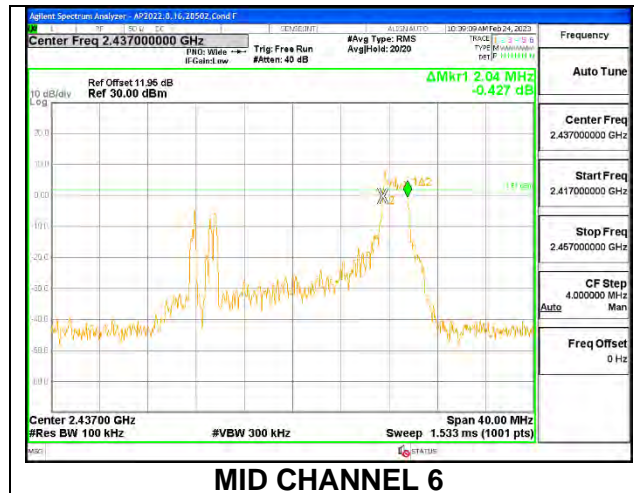

ANT 3 SISO MODE: 26-Tones, RU Index 0

Channel	Frequency (MHz)	6dB Bandwidth (MHz)	Minimum Limit (MHz)
Low 1	2412	2.08	0.5
Mid 6	2437	2.16	0.5
High 11	2462	2.12	0.5
High 12	2467	2.08	0.5
High 13	2472	2.16	0.5

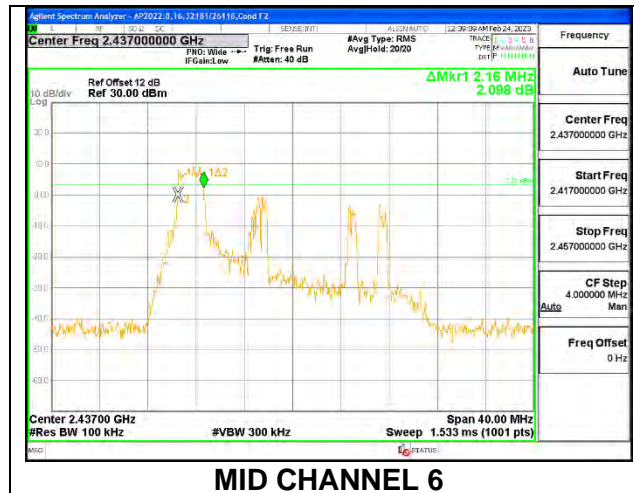

ANT 3 SISO MODE: 26-Tones, RU Index 4

Channel	Frequency (MHz)	6dB Bandwidth (MHz)	Minimum Limit (MHz)
Low 1	2412	2.64	0.5
Mid 6	2437	2.72	0.5
High 11	2462	2.68	0.5
High 12	2467	2.64	0.5
High 13	2472	2.72	0.5



ANT 3 SISO MODE: 26-Tones, RU Index 8

Channel	Frequency (MHz)	6dB Bandwidth (MHz)	Minimum Limit (MHz)
Low 1	2412	2.16	0.5
Mid 6	2437	2.12	0.5
High 11	2462	2.12	0.5
High 12	2467	2.12	0.5
High 13	2472	2.12	0.5

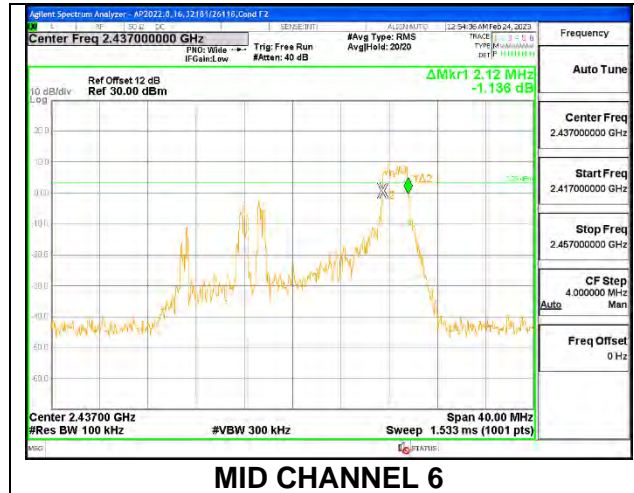

9.3.3. 802.11ax HE20 OFDMA MODE 2TX

ANT 4 + ANT 3 2TX MODE: 26-Tones, RU Index 0

Channel	Frequency (MHz)	6dB BW(MHz) ANT 4	6dB BW (MHz) ANT 3	Minimum Limit (MHz)
Low 1	2412	2.16	2.12	0.5
Mid 6	2437	2.12	2.08	0.5
High 11	2462	2.16	2.08	0.5
High 12	2467	2.16	2.16	0.5
High 13	2472	2.08	2.08	0.5

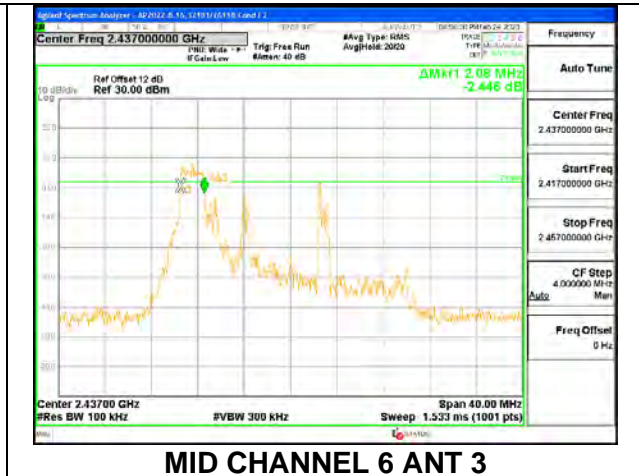
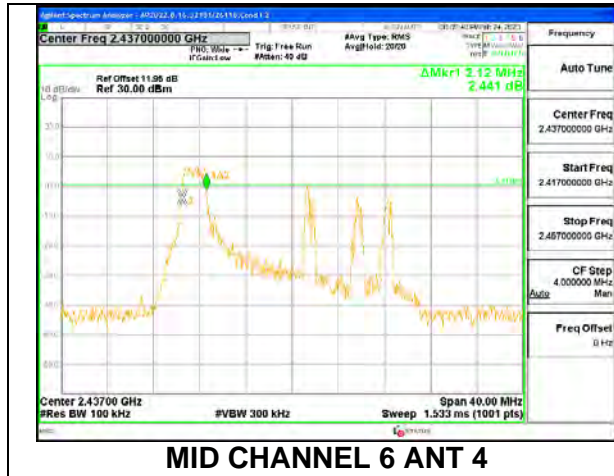

ANT 4 + ANT 3 2TX MODE: 26-Tones, RU Index 4

Channel	Frequency (MHz)	6dB BW(MHz) ANT 4	6dB BW (MHz) ANT 3	Minimum Limit (MHz)
Low 1	2412	2.64	2.68	0.5
Mid 6	2437	2.72	2.68	0.5
High 11	2462	2.72	2.64	0.5
High 12	2467	2.64	2.80	0.5
High 13	2472	2.68	2.64	0.5

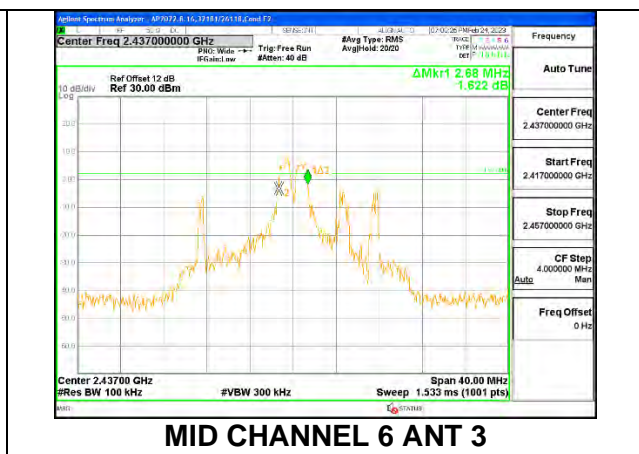
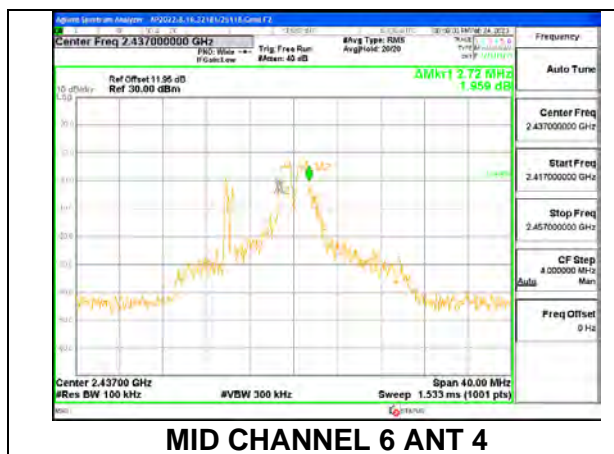

ANT 4 + ANT 3 2TX MODE: 26-Tones, RU Index 8

Channel	Frequency (MHz)	6dB BW(MHz) ANT 4	6dB BW (MHz) ANT 3	Minimum Limit (MHz)
Low 1	2412	2.12	2.16	0.5
Mid 6	2437	2.12	2.12	0.5
High 11	2462	2.12	2.12	0.5
High 12	2467	2.12	2.12	0.5
High 13	2472	2.20	2.12	0.5

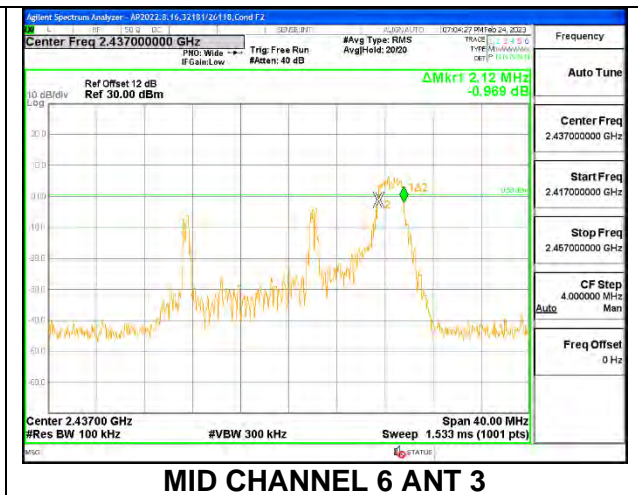
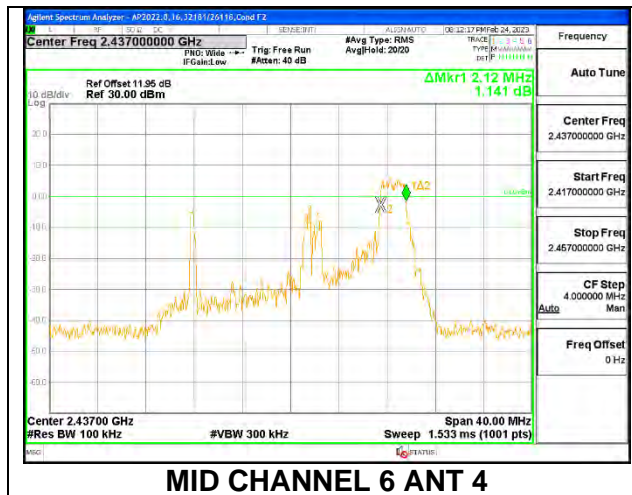

9.4. OUTPUT POWER

LIMITS

FCC §15.247 (b) (3)

RSS-247 5.4 (d)

For systems using digital modulation in the 902–928 MHz, 2400–2483.5 MHz, and 5725–5850 MHz bands: 1 Watt, based on the use of antennas with directional gains that do not exceed 6 dBi. If transmitting antennas of directional gain greater than 6 dBi are used, the conducted output power from the intentional radiator shall be reduced by the amount in dB that the directional gain of the antenna exceeds 6 dBi.

TEST PROCEDURE

Measurements perform using a wideband RF power meter.

The power output was measured on the EUT antenna port using SMA cable with 10dB attenuator connected to a power meter via wideband power sensor. Average output power was read directly from the power meter.

DIRECTIONAL ANTENNA GAIN

For 1 TX:

There is only one transmitter output therefore the directional gain is equal to the antenna gain.

For 2 TX:

Tx chains are uncorrelated for power and correlated for PSD due to the device supporting CDD in all MIMO modes. The directional gains are as follows:

Band (GHz)	ANT 4 Gain (dBi)	ANT 3 Gain (dBi)	Uncorrelated Chains Directional Gain (dBi)	Correlated Chains Directional Gain (dBi)
2.4	-4.00	-1.50	-2.57	0.35

DIRECTIONAL GAIN CALCULATION:

ANSI C63.10-2013 section 14.4.3

Uncorrelated directional gain= $10 \cdot \text{LOG}((10^{(\text{Ant1}/10)} + 10^{(\text{Ant2}/10)})/2)$
Correlated directional Gain= $10 \cdot \text{LOG}(((10^{(\text{Ant1}/20)} + 10^{(\text{Ant2}/20)})^2)/2)$

Sample Calculation:

Ant4=-4.0, Ant3=-1.5

Uncorrelated Antenna gain= $10 \log[(10^{(-4.0/10)} + 10^{(-1.5/10)})/2] = -2.57 \text{dBi}$

Correlated Antenna gain= $10 \log[(10^{(-4.0/20)} + 10^{(-1.5/20)})^2/2] = 0.35$

RESULTS

9.4.1. 802.11b MODE 1TX

Test Engineer:	28502
Test Date:	2/23/2023

1TX ANT 4 MODE

Limits

Channel	Frequency (MHz)	Directional Gain (dBi)	FCC Power Limit (dBm)	ISED Power Limit (dBm)	ISED EIRP Limit (dBm)	Max Power (dBm)
Low 1	2412	-4.00	30.00	30	36	30.00
Mid 6	2437	-4.00	30.00	30	36	30.00
High 11	2462	-4.00	30.00	30	36	30.00
High 12	2467	-4.00	30.00	30	36	30.00
High 13	2472	-4.00	30.00	30	36	30.00

Results

Channel	Frequency (MHz)	Meas Power (dBm)	Total Corr'd Power (dBm)	Power Limit (dBm)	Margin (dB)
Low 1	2412	20.47	20.47	30.00	-9.53
Mid 6	2437	21.45	21.45	30.00	-8.55
High 11	2462	21.47	21.47	30.00	-8.53
High 12	2467	20.48	20.48	30.00	-9.52
High 13	2472	17.93	17.93	30.00	-12.07

1TX ANT 3 MODE

Limits

Channel	Frequency (MHz)	Directional Gain (dBi)	FCC Power Limit (dBm)	ISED Power Limit (dBm)	ISED EIRP Limit (dBm)	Max Power (dBm)
Low 1	2412	-1.50	30.00	30	36	30.00
Mid 6	2437	-1.50	30.00	30	36	30.00
High 11	2462	-1.50	30.00	30	36	30.00
High 12	2467	-1.50	30.00	30	36	30.00
High 13	2472	-1.50	30.00	30	36	30.00

Results

Channel	Frequency (MHz)	Meas Power (dBm)	Total Corr'd Power (dBm)	Power Limit (dBm)	Margin (dB)
Low 1	2412	20.47	20.47	30.00	-9.53
Mid 6	2437	21.45	21.45	30.00	-8.55
High 11	2462	21.43	21.43	30.00	-8.57
High 12	2467	20.45	20.45	30.00	-9.55
High 13	2472	17.92	17.92	30.00	-12.08

9.4.2. 802.11n HT20 MODE

Test Engineer:	28502
Test Date:	2/23/2023

1TX ANT 4 MODE

Limits

Channel	Frequency (MHz)	Directional Gain (dBi)	FCC Power Limit (dBm)	ISED Power Limit (dBm)	ISED EIRP Limit (dBm)	Max Power (dBm)
Low 1	2412	-4.00	30.00	30	36	30.00
Low 2	2417	-4.00	30.00	30	36	30.00
Low 3	2422	-4.00	30.00	30	36	30.00
Mid 6	2437	-4.00	30.00	30	36	30.00
High 9	2452	-4.00	30.00	30	36	30.00
High 10	2457	-4.00	30.00	30	36	30.00
High 11	2462	-4.00	30.00	30	36	30.00
High 12	2467	-4.00	30.00	30	36	30.00
High 13	2472	-4.00	30.00	30	36	30.00

Duty Cycle CF (dB)	0.00	Included in Calculations of Corr'd Power
---------------------------	------	---

Results

Channel	Frequency (MHz)	Meas Power (dBm)	Total Corr'd Power (dBm)	Power Limit (dBm)	Margin (dB)
Low 1	2412	17.94	17.94	30.00	-12.06
Low 2	2417	19.48	19.48	30.00	-10.52
Low 3	2422	21.48	21.48	30.00	-8.52
Mid 6	2437	21.45	21.45	30.00	-8.55
High 9	2452	20.99	20.99	30.00	-9.01
High 10	2457	19.49	19.49	30.00	-10.51
High 11	2462	18.49	18.49	30.00	-11.51
High 12	2467	15.95	15.95	30.00	-14.05
High 13	2472	14.35	14.35	30.00	-15.65

1TX ANT 3 MODE

Limits

Channel	Frequency (MHz)	Directional Gain (dBi)	FCC Power Limit (dBm)	ISED Power Limit (dBm)	ISED EIRP Limit (dBm)	Max Power (dBm)
Low 1	2412	-1.50	30.00	30	36	30.00
Low 2	2417	-1.50	30.00	30	36	30.00
Low 3	2422	-1.50	30.00	30	36	30.00
Mid 6	2437	-1.50	30.00	30	36	30.00
High 9	2452	-1.50	30.00	30	36	30.00
High 10	2457	-1.50	30.00	30	36	30.00
High 11	2462	-1.50	30.00	30	36	30.00
High 12	2467	-1.50	30.00	30	36	30.00
High 13	2472	-1.50	30.00	30	36	30.00

Duty Cycle CF (dB)	0.00	Included in Calculations of Corr'd Power
---------------------------	------	---

Results

Channel	Frequency (MHz)	Meas Power (dBm)	Total Corr'd Power (dBm)	Power Limit (dBm)	Margin (dB)
Low 1	2412	17.96	17.96	30.00	-12.04
Low 2	2417	19.43	19.43	30.00	-10.57
Low 3	2422	21.48	21.48	30.00	-8.52
Mid 6	2437	21.42	21.42	30.00	-8.58
High 9	2452	20.90	20.90	30.00	-9.10
High 10	2457	19.45	19.45	30.00	-10.55
High 11	2462	18.41	18.41	30.00	-11.59
High 12	2467	15.99	15.99	30.00	-14.01
High 13	2472	14.41	14.41	30.00	-15.59

9.4.3. 802.11n HT20 CDD MODE 2TX

Test Engineer:	28502
Test Date:	2/23/2023

Limits

Channel	Frequency (MHz)	Directional Gain (dBi)	FCC/ISED Power Limit (dBm)	ISED EIRP Limit (dBm)	Max Power (dBm)
Low 1	2412	-2.57	30.00	36	30.00
Low 2	2417	-2.57	30.00	36	30.00
Low 3	2422	-2.57	30.00	36	30.00
Low 4	2427	-2.57	30.00	36	30.00
Mid 6	2437	-2.57	30.00	36	30.00
High 8	2447	-2.57	30.00	36	30.00
High 9	2452	-2.57	30.00	36	30.00
High 10	2457	-2.57	30.00	36	30.00
High 11	2462	-2.57	30.00	36	30.00
High 12	2467	-2.57	30.00	36	30.00
High 13	2472	-2.57	30.00	36	30.00

Duty Cycle CF (dB)	0.00	Included in Calculations of Corr'd Power
---------------------------	------	---

Results

Channel	Frequency (MHz)	ANT 4 Meas Power (dBm)	ANT 3 Meas Power (dBm)	Total Corr'd Power (dBm)	Power Limit (dBm)	Margin (dB)
Low 1	2412	17.35	17.41	20.39	30.00	-9.61
Low 2	2417	18.49	18.41	21.46	30.00	-8.54
Low 3	2422	19.98	19.93	22.97	30.00	-7.03
Low 4	2427	21.46	21.48	24.48	30.00	-5.52
Mid 6	2437	21.45	21.45	24.46	30.00	-5.54
High 8	2447	21.45	21.41	24.44	30.00	-5.56
High 9	2452	19.45	19.41	22.44	30.00	-7.56
High 10	2457	18.45	18.41	21.44	30.00	-8.56
High 11	2462	17.48	17.49	20.50	30.00	-9.50
High 12	2467	14.94	14.98	17.97	30.00	-12.03
High 13	2472	14.24	14.25	17.26	30.00	-12.74

9.4.4. 802.11ax HE20 MODE

Test Engineer:	28502
Test Date:	2/23/2023

1TX ANT 4 MODE: 26-Tones, RU Index 0

Limits

Channel	Frequency (MHz)	Directional Gain (dBi)	FCC Power Limit (dBm)	ISED Power Limit (dBm)	ISED EIRP Limit (dBm)	Max Power (dBm)
Low 1	2412	-4.00	30.00	30	36	30.00
Mid 6	2437	-4.00	30.00	30	36	30.00
High 11	2462	-4.00	30.00	30	36	30.00
High 12	2467	-4.00	30.00	30	36	30.00
High 13	2472	-4.00	30.00	30	36	30.00

Results

Channel	Frequency (MHz)	Meas Power (dBm)	Total Corr'd Power (dBm)	Power Limit (dBm)	Margin (dB)
Low 1	2412	13.37	13.37	30.00	-16.63
Mid 6	2437	13.44	13.44	30.00	-16.56
High 11	2462	13.41	13.41	30.00	-16.59
High 12	2467	13.30	13.30	30.00	-16.70
High 13	2472	-0.18	-0.18	30.00	-30.18

1TX ANT 4 MODE: 26-Tones, RU Index 4

Limits

Channel	Frequency (MHz)	Directional Gain (dBi)	FCC Power Limit (dBm)	ISED Power Limit (dBm)	ISED EIRP Limit (dBm)	Max Power (dBm)
Low 1	2412	-4.00	30.00	30	36	30.00
Mid 6	2437	-4.00	30.00	30	36	30.00
High 11	2462	-4.00	30.00	30	36	30.00
High 12	2467	-4.00	30.00	30	36	30.00
High 13	2472	-4.00	30.00	30	36	30.00

Results

Channel	Frequency (MHz)	Meas Power (dBm)	Total Corr'd Power (dBm)	Power Limit (dBm)	Margin (dB)
Low 1	2412	13.46	13.46	30.00	-16.54
Mid 6	2437	13.40	13.40	30.00	-16.60
High 11	2462	13.42	13.42	30.00	-16.58
High 12	2467	13.42	13.42	30.00	-16.58
High 13	2472	-0.74	-0.74	30.00	-30.74

1TX ANT 4 MODE: 26-Tones, RU Index 8

Limits

Channel	Frequency (MHz)	Directional Gain (dBi)	FCC Power Limit (dBm)	ISED Power Limit (dBm)	ISED EIRP Limit (dBm)	Max Power (dBm)
Low 1	2412	-4.00	30.00	30	36	30.00
Mid 6	2437	-4.00	30.00	30	36	30.00
High 11	2462	-4.00	30.00	30	36	30.00
High 12	2467	-4.00	30.00	30	36	30.00
High 13	2472	-4.00	30.00	30	36	30.00

Results

Channel	Frequency (MHz)	Meas Power (dBm)	Total Corr'd Power (dBm)	Power Limit (dBm)	Margin (dB)
Low 1	2412	13.42	13.42	30.00	-16.58
Mid 6	2437	13.38	13.38	30.00	-16.62
High 11	2462	13.41	13.41	30.00	-16.59
High 12	2467	13.42	13.42	30.00	-16.58
High 13	2472	-0.15	-0.15	30.00	-30.15

1TX ANT 4 MODE: SU Mode

Limits

Channel	Frequency (MHz)	Directional Gain (dBi)	FCC Power Limit (dBm)	ISED Power Limit (dBm)	ISED EIRP Limit (dBm)	Max Power (dBm)
Low 1	2412	-4.00	30.00	30	36	30.00
Low 2	2417	-4.00	30.00	30	36	30.00
Low 3	2422	-4.00	30.00	30	36	30.00
Mid 6	2437	-4.00	30.00	30	36	30.00
High 9	2452	-4.00	30.00	30	36	30.00
High 10	2457	-4.00	30.00	30	36	30.00
High 11	2462	-4.00	30.00	30	36	30.00
High 12	2467	-4.00	30.00	30	36	30.00
High 13	2472	-4.00	30.00	30	36	30.00

Results

Channel	Frequency (MHz)	Meas Power (dBm)	Total Corr'd Power (dBm)	Power Limit (dBm)	Margin (dB)
Low 1	2412	16.90	16.90	30.00	-13.10
Low 2	2417	17.98	17.98	30.00	-12.02
Low 3	2422	21.48	21.48	30.00	-8.52
Mid 6	2437	21.45	21.45	30.00	-8.55
High 9	2452	21.40	21.40	30.00	-8.60
High 10	2457	17.91	17.91	30.00	-12.09
High 11	2462	16.96	16.96	30.00	-13.04
High 12	2467	14.91	14.91	30.00	-15.09
High 13	2472	9.96	9.96	30.00	-20.04

1TX ANT 3 MODE: 26-Tones, RU Index 0

Limits

Channel	Frequency (MHz)	Directional Gain (dBi)	FCC Power Limit (dBm)	ISED Power Limit (dBm)	ISED EIRP Limit (dBm)	Max Power (dBm)
Low 1	2412	-1.50	30.00	30	36	30.00
Mid 6	2437	-1.50	30.00	30	36	30.00
High 11	2462	-1.50	30.00	30	36	30.00
High 12	2467	-1.50	30.00	30	36	30.00
High 13	2472	-1.50	30.00	30	36	30.00

Results

Channel	Frequency (MHz)	Meas Power (dBm)	Total Corr'd Power (dBm)	Power Limit (dBm)	Margin (dB)
Low 1	2412	13.41	13.41	30.00	-16.59
Mid 6	2437	13.45	13.45	30.00	-16.55
High 11	2462	13.43	13.43	30.00	-16.57
High 12	2467	13.39	13.39	30.00	-16.61
High 13	2472	-0.12	-0.12	30.00	-30.12

1TX ANT 3 MODE: 26-Tones, RU Index 4

Limits

Channel	Frequency (MHz)	Directional Gain (dBi)	FCC Power Limit (dBm)	ISED Power Limit (dBm)	ISED EIRP Limit (dBm)	Max Power (dBm)
Low 1	2412	-1.50	30.00	30	36	30.00
Mid 6	2437	-1.50	30.00	30	36	30.00
High 11	2462	-1.50	30.00	30	36	30.00
High 12	2467	-1.50	30.00	30	36	30.00
High 13	2472	-1.50	30.00	30	36	30.00

Results

Channel	Frequency (MHz)	Meas Power (dBm)	Total Corr'd Power (dBm)	Power Limit (dBm)	Margin (dB)
Low 1	2412	13.46	13.46	30.00	-16.54
Mid 6	2437	13.47	13.47	30.00	-16.53
High 11	2462	13.48	13.48	30.00	-16.52
High 12	2467	13.48	13.48	30.00	-16.52
High 13	2472	-0.18	-0.18	30.00	-30.18

1TX ANT 3 MODE: 26-Tones, RU Index 8

Limits

Channel	Frequency (MHz)	Directional Gain (dBi)	FCC Power Limit (dBm)	ISED Power Limit (dBm)	ISED EIRP Limit (dBm)	Max Power (dBm)
Low 1	2412	-1.50	30.00	30	36	30.00
Mid 6	2437	-1.50	30.00	30	36	30.00
High 11	2462	-1.50	30.00	30	36	30.00
High 12	2467	-1.50	30.00	30	36	30.00
High 13	2472	-1.50	30.00	30	36	30.00

Results

Channel	Frequency (MHz)	Meas Power (dBm)	Total Corr'd Power (dBm)	Power Limit (dBm)	Margin (dB)
Low 1	2412	13.45	13.45	30.00	-16.55
Mid 6	2437	13.48	13.48	30.00	-16.52
High 11	2462	13.45	13.45	30.00	-16.55
High 12	2467	13.41	13.41	30.00	-16.59
High 13	2472	-0.09	-0.09	30.00	-30.09

1TX ANT 3 MODE: SU Mode

Limits

Channel	Frequency (MHz)	Directional Gain (dBi)	FCC Power Limit (dBm)	ISED Power Limit (dBm)	ISED EIRP Limit (dBm)	Max Power (dBm)
Low 1	2412	-1.50	30.00	30	36	30.00
Low 2	2417	-1.50	30.00	30	36	30.00
Low 3	2422	-1.50	30.00	30	36	30.00
Mid 6	2437	-1.50	30.00	30	36	30.00
High 9	2452	-1.50	30.00	30	36	30.00
High 10	2457	-1.50	30.00	30	36	30.00
High 11	2462	-1.50	30.00	30	36	30.00
High 12	2467	-1.50	30.00	30	36	30.00
High 13	2472	-1.50	30.00	30	36	30.00

Results

Channel	Frequency (MHz)	Meas Power (dBm)	Total Corr'd Power (dBm)	Power Limit (dBm)	Margin (dB)
Low 1	2412	16.92	16.92	30.00	-13.08
Low 2	2417	17.95	17.95	30.00	-12.05
Low 3	2422	21.40	21.40	30.00	-8.60
Mid 6	2437	21.48	21.48	30.00	-8.52
High 9	2452	21.40	21.40	30.00	-8.60
High 10	2457	17.90	17.90	30.00	-12.10
High 11	2462	16.96	16.96	30.00	-13.04
High 12	2467	14.95	14.95	30.00	-15.05
High 13	2472	9.91	9.91	30.00	-20.09

9.4.5. 802.11ax HE20 OFDMA MODE 2TX

Test Engineer:	28502
Test Date:	2/23/2023

ANT 4 + ANT 3 2TX MODE: 26-Tones, RU Index 0

Limits

Channel	Frequency (MHz)	Directional Gain (dBi)	FCC/ISED Power Limit (dBm)	ISED EIRP Limit (dBm)	Max Power (dBm)
Low 1	2412	-2.57	30.00	36	30.00
Mid 6	2437	-2.57	30.00	36	30.00
High 11	2462	-2.57	30.00	36	30.00
High 12	2467	-2.57	30.00	36	30.00
High 13	2472	-2.57	30.00	36	30.00

Results

Channel	Frequency (MHz)	ANT4 Meas Power (dBm)	ANT3 Meas Power (dBm)	Total Corr'd Power (dBm)	Power Limit (dBm)	Margin (dB)
Low 1	2412	13.48	13.41	16.46	30.00	-13.54
Mid 6	2437	13.49	13.47	16.49	30.00	-13.51
High 11	2462	13.45	13.46	16.47	30.00	-13.53
High 12	2467	12.97	12.92	15.96	30.00	-14.04
High 13	2472	-0.09	-0.09	2.92	30.00	-27.08

ANT 4 + ANT 3 2TX MODE: 26-Tones, RU Index 4

Limits

Channel	Frequency (MHz)	Directional Gain (dBi)	FCC/ISED Power Limit (dBm)	ISED EIRP Limit (dBm)	Max Power (dBm)
Low 1	2412	-2.57	30.00	36	30.00
Mid 6	2437	-2.57	30.00	36	30.00
High 11	2462	-2.57	30.00	36	30.00
High 12	2467	-2.57	30.00	36	30.00
High 13	2472	-2.57	30.00	36	30.00

Results

Channel	Frequency (MHz)	ANT 4 Meas Power (dBm)	ANT 3 Meas Power (dBm)	Total Corr'd Power (dBm)	Power Limit (dBm)	Margin (dB)
Low 1	2412	13.48	13.42	16.46	30.00	-13.54
Mid 6	2437	13.42	13.43	16.44	30.00	-13.56
High 11	2462	13.48	13.41	16.46	30.00	-13.54
High 12	2467	12.94	12.91	15.94	30.00	-14.06
High 13	2472	-0.20	-0.10	2.86	30.00	-27.14

ANT 4 + ANT 3 2TX MODE: 26-Tones, RU Index 8

Limits

Channel	Frequency (MHz)	Directional Gain (dBi)	FCC/ISED Power Limit (dBm)	ISED EIRP Limit (dBm)	Max Power (dBm)
Low 1	2412	-2.57	30.00	36	30.00
Mid 6	2437	-2.57	30.00	36	30.00
High 11	2462	-2.57	30.00	36	30.00
High 12	2467	-2.57	30.00	36	30.00
High 13	2472	-2.57	30.00	36	30.00

Results

Channel	Frequency (MHz)	ANT 4 Meas Power (dBm)	ANT 3 Meas Power (dBm)	Total Corr'd Power (dBm)	Power Limit (dBm)	Margin (dB)
Low 1	2412	13.44	13.45	16.46	30.00	-13.54
Mid 6	2437	13.41	13.45	16.44	30.00	-13.56
High 11	2462	13.48	13.43	16.47	30.00	-13.53
High 12	2467	12.95	12.91	15.94	30.00	-14.06
High 13	2472	-0.50	-0.28	2.62	30.00	-27.38

ANT 4 + ANT 3 2TX MODE: SU Mode

Limits

Channel	Frequency (MHz)	Directional Gain (dBi)	FCC/ISED Power Limit (dBm)	ISED EIRP Limit (dBm)	Max Power (dBm)
Low 1	2412	-2.57	30.00	36	30.00
Low 2	2417	-2.57	30.00	36	30.00
Low 3	2422	-2.57	30.00	36	30.00
Low 4	2427	-2.57	30.00	36	30.00
Mid 6	2437	-2.57	30.00	36	30.00
High 8	2447	-2.57	30.00	36	30.00
High 9	2452	-2.57	30.00	36	30.00
High 10	2457	-2.57	30.00	36	30.00
High 11	2462	-2.57	30.00	36	30.00
High 12	2467	-2.57	30.00	36	30.00
High 13	2472	-2.57	30.00	36	30.00

Results

Channel	Frequency (MHz)	ANT 4 Meas Power (dBm)	ANT 3 Meas Power (dBm)	Total Corr'd Power (dBm)	Power Limit (dBm)	Margin (dB)
Low 1	2412	15.95	15.93	18.95	30.00	-11.05
Low 2	2417	16.98	16.96	19.98	30.00	-10.02
Low 3	2422	18.91	18.95	21.94	30.00	-8.06
Low 4	2427	21.47	21.41	24.45	30.00	-5.55
Mid 6	2437	21.40	21.42	24.42	30.00	-5.58
High 8	2447	21.40	21.41	24.42	30.00	-5.58
High 9	2452	18.47	18.40	21.45	30.00	-8.55
High 10	2457	16.93	16.89	19.92	30.00	-10.08
High 11	2462	15.96	15.93	18.96	30.00	-11.04
High 12	2467	13.92	13.95	16.95	30.00	-13.05
High 13	2472	8.95	8.89	11.93	30.00	-18.07

9.5. POWER SPECTRAL DENSITY

LIMITS

FCC §15.247 (e)

RSS-247 (5.2) (b)

The power spectral density conducted from the transmitter to the antenna shall not be greater than 8 dBm in any 3 kHz band during any time interval of continuous transmission.

RESULTS

Only Mid channel plot is reported to show setting parameter complies with testing method/procedure.

Note: RBW setting is used greater than 3KHz on PSD measurement

9.5.1. 802.11b MODE 1TX

1TX ANT 4 MODE

Duty Cycle CF (dB)		0.00	Included in Calculations of Corr'd PSD		
Channel	Frequency (MHz)	Meas (dBm/ 3kHz)	Total Corr'd PSD (dBm/ 3kHz)	Limit (dBm/ 3kHz)	Margin (dB)
Low 1	2412	-1.329	-1.329	8.0	-9.3
Mid 6	2437	0.276	0.276	8.0	-7.7
High 11	2462	-0.098	-0.098	8.0	-8.1
High 12	2467	-1.076	-1.076	8.0	-9.1
High 13	2472	-3.425	-3.425	8.0	-11.4

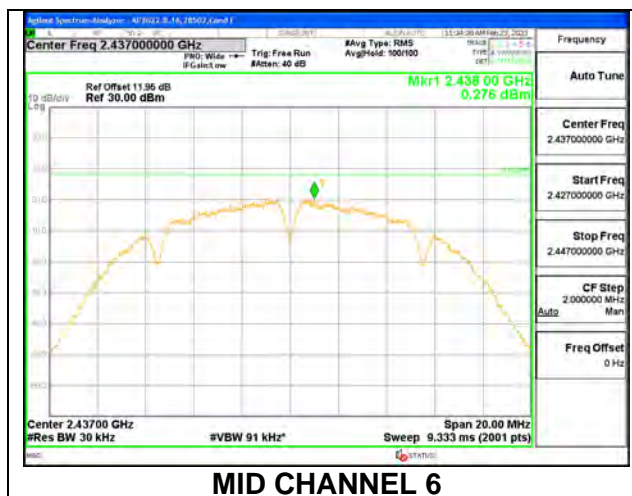

1TX ANT 3 MODE

Duty Cycle CF (dB)		0.00	Included in Calculations of Corr'd PSD		
Channel	Frequency (MHz)	Meas (dBm/ 3kHz)	Total Corr'd PSD (dBm/ 3kHz)	Limit (dBm/ 3kHz)	Margin (dB)
Low 1	2412	-0.978	-0.978	8.0	-9.0
Mid 6	2437	0.113	0.113	8.0	-7.9
High 11	2462	-0.223	-0.223	8.0	-8.2
High 12	2467	-0.975	-0.975	8.0	-9.0
High 13	2472	-3.803	-3.803	8.0	-11.8

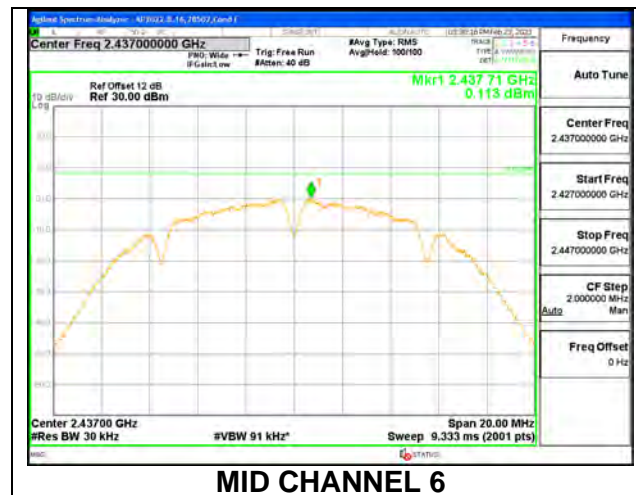

9.5.2. 802.11n HT20 MODE

1TX ANT 4 MODE

Duty Cycle CF (dB)		Included in Calculations of Corr'd PSD			
Channel	Frequency (MHz)	Meas (dBm/ 3kHz)	Total Corr'd PSD (dBm/ 3kHz)	Limit (dBm/ 3kHz)	Margin (dB)
Low 1	2412	-4.949	-4.949	8.0	-12.9
Low 2	2417	-3.522	-3.522	8.0	-11.5
Low 3	2422	-1.654	-1.654	8.0	-9.7
Mid 6	2437	-1.699	-1.699	8.0	-9.7
High 9	2452	-2.227	-2.227	8.0	-10.2
High 10	2457	-3.699	-3.699	8.0	-11.7
High 11	2462	-4.623	-4.623	8.0	-12.6
High 12	2467	-6.592	-6.592	8.0	-14.6
High 13	2472	-8.928	-8.928	8.0	-16.9

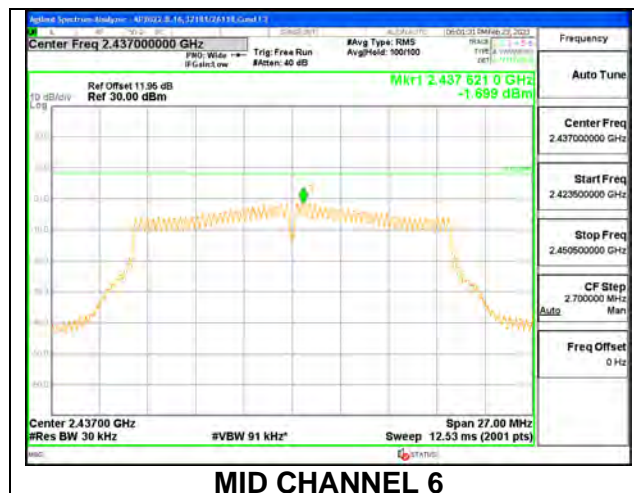

1TX ANT 3 MODE

Duty Cycle CF (dB)		0.00	Included in Calculations of Corr'd PSD		
Channel	Frequency (MHz)	Meas (dBm/ 3kHz)	Total Corr'd PSD (dBm/ 3kHz)	Limit (dBm/ 3kHz)	Margin (dB)
Low 1	2412	-5.079	-5.079	8.0	-13.1
Low 2	2417	-3.241	-3.241	8.0	-11.2
Low 3	2422	-1.603	-1.603	8.0	-9.6
Mid 6	2437	-1.536	-1.536	8.0	-9.5
High 9	2452	-1.827	-1.827	8.0	-9.8
High 10	2457	-3.045	-3.045	8.0	-11.0
High 11	2462	-4.750	-4.750	8.0	-12.8
High 12	2467	-7.074	-7.074	8.0	-15.1
High 13	2472	-8.773	-8.773	8.0	-16.8

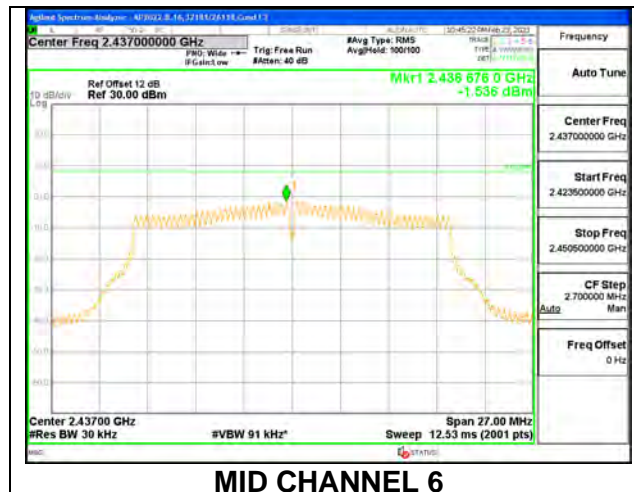

9.5.3. 802.11n HT20 CDD MODE 2TX

Duty Cycle CF (dB)		0.00		Included in Calculations of Corr'd PSD		
Channel	Frequency (MHz)	ANT 4 Meas (dBm/ 3kHz)	ANT 3 Meas (dBm/ 3kHz)	Total Corr'd PSD (dBm/ 3kHz)	Limit (dBm/ 3kHz)	Margin (dB)
Low 1	2412	-5.969	-5.516	-2.726	8.0	-10.7
Low 2	2417	-4.566	-4.978	-1.757	8.0	-9.8
Low 3	2422	-2.246	-2.947	0.428	8.0	-7.6
Mid 6	2437	-1.684	-1.359	1.492	8.0	-6.5
High 9	2452	-3.462	-3.537	-0.489	8.0	-8.5
High 10	2457	-4.819	-4.742	-1.770	8.0	-9.8
High 11	2462	-5.798	-5.241	-2.500	8.0	-10.5
High 12	2467	-7.919	-7.357	-4.619	8.0	-12.6
High 13	2472	-8.547	-9.076	-5.793	8.0	-13.8

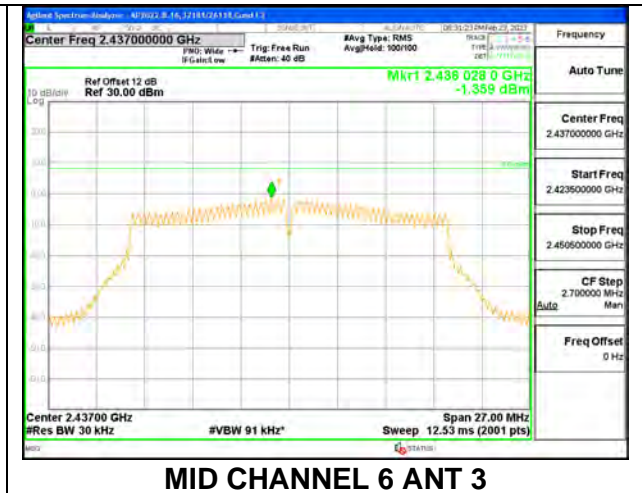
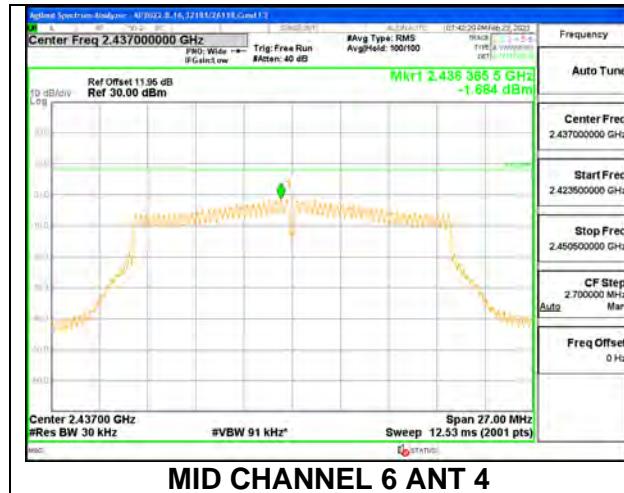

9.5.4. 802.11ax HE20 MODE

1TX ANT 4 MODE , 26-Tone RU Index 0

Duty Cycle CF (dB)	0.00				
Channel	Frequency (MHz)	Meas (dBm/ 3kHz)	Total Corr'd PSD (dBm/ 3kHz)	Limit (dBm/ 3kHz)	Margin (dB)
Low 1	2412	-4.110	-4.110	8.0	-12.1
Mid 6	2437	-3.729	-3.729	8.0	-11.7
High 11	2462	-3.757	-3.757	8.0	-11.8
High 12	2467	-3.625	-3.625	8.0	-11.6
High 13	2472	-16.190	-16.190	8.0	-24.2

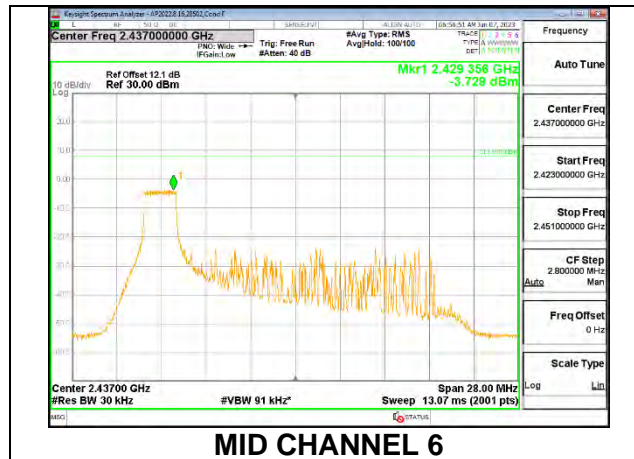

1TX ANT 4 MODE , 26-Tone RU Index 4

Duty Cycle CF (dB)	0.00				
Channel	Frequency (MHz)	Meas (dBm/ 3kHz)	Total Corr'd PSD (dBm/ 3kHz)	Limit (dBm/ 3kHz)	Margin (dB)
Low 1	2412	-3.772	-3.772	8.0	-11.8
Mid 6	2437	-3.775	-3.775	8.0	-11.8
High 11	2462	-3.752	-3.752	8.0	-11.8
High 12	2467	-3.371	-3.371	8.0	-11.4
High 13	2472	-16.021	-16.021	8.0	-24.0

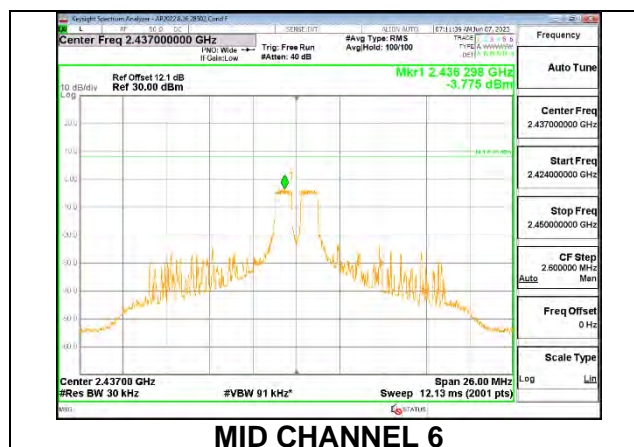

1TX ANT 4 MODE , 26-Tone RU Index 8

Duty Cycle CF (dB)		0.00	Included in Calculations of Corr'd PSD		
Channel	Frequency (MHz)	Meas (dBm/ 3kHz)	Total Corr'd PSD (dBm/ 3kHz)	Limit (dBm/ 3kHz)	Margin (dB)
Low 1	2412	-3.535	-3.535	8.0	-11.5
Mid 6	2437	-3.529	-3.529	8.0	-11.5
High 11	2462	-3.639	-3.639	8.0	-11.6
High 12	2467	-3.583	-3.583	8.0	-11.6
High 13	2472	-16.071	-16.071	8.0	-24.1

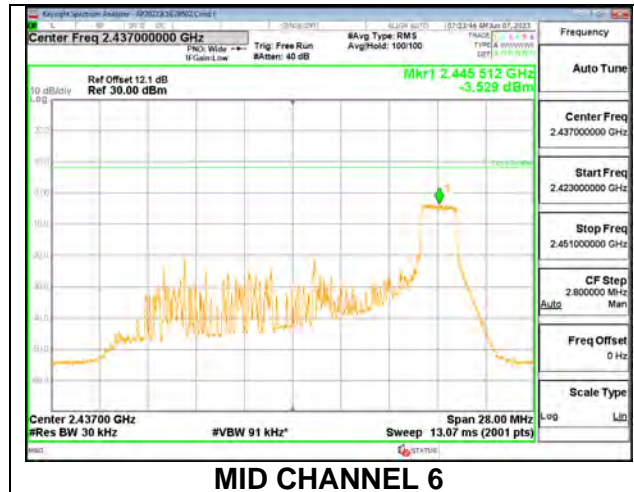

1TX ANT 4 MODE , SU Mode

Duty Cycle CF (dB)		0.00	Included in Calculations of Corr'd PSD		
Channel	Frequency (MHz)	Meas (dBm/ 3kHz)	Total Corr'd PSD (dBm/ 3kHz)	Limit (dBm/ 3kHz)	Margin (dB)
Low 1	2412	-8.780	-8.780	8.0	-16.8
Low 2	2417	-7.204	-7.204	8.0	-15.2
Low 3	2422	-3.801	-3.801	8.0	-11.8
Mid 6	2437	-3.745	-3.745	8.0	-11.7
High 9	2452	-3.839	-3.839	8.0	-11.8
High 10	2457	-7.099	-7.099	8.0	-15.1
High 11	2462	-8.134	-8.134	8.0	-16.1
High 12	2467	-10.497	-10.497	8.0	-18.5
High 13	2472	-16.028	-16.028	8.0	-24.0

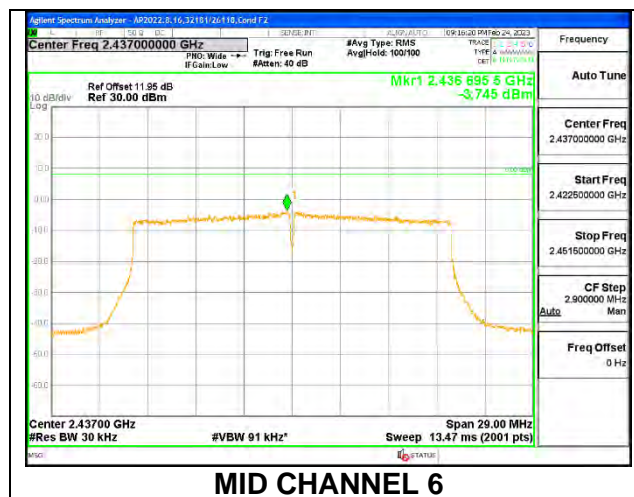

1TX ANT 3 MODE , 26-Tone RU Index 0

Duty Cycle CF (dB)		Included in Calculations of Corr'd PSD			
Channel	Frequency (MHz)	Meas (dBm/ 3kHz)	Total Corr'd PSD (dBm/ 3kHz)	Limit (dBm/ 3kHz)	Margin (dB)
Low 1	2412	-3.507	-3.507	8.0	-11.5
Mid 6	2437	-3.808	-3.808	8.0	-11.8
High 11	2462	-3.809	-3.809	8.0	-11.8
High 12	2467	-3.566	-3.566	8.0	-11.6
High 13	2472	-16.288	-16.288	8.0	-24.3

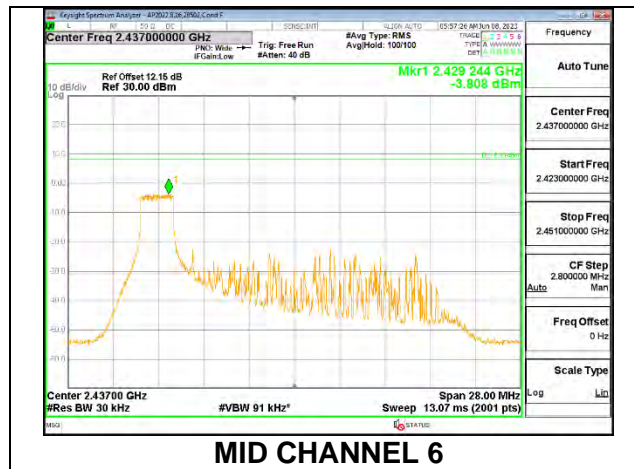

1TX ANT 3 MODE , 26-Tone RU Index 4

Duty Cycle CF (dB)		Included in Calculations of Corr'd PSD			
Channel	Frequency (MHz)	Meas (dBm/ 3kHz)	Total Corr'd PSD (dBm/ 3kHz)	Limit (dBm/ 3kHz)	Margin (dB)
Low 1	2412	-3.638	-3.638	8.0	-11.6
Mid 6	2437	-3.722	-3.722	8.0	-11.7
High 11	2462	-3.767	-3.767	8.0	-11.8
High 12	2467	-3.746	-3.746	8.0	-11.7
High 13	2472	-16.001	-16.001	8.0	-24.0

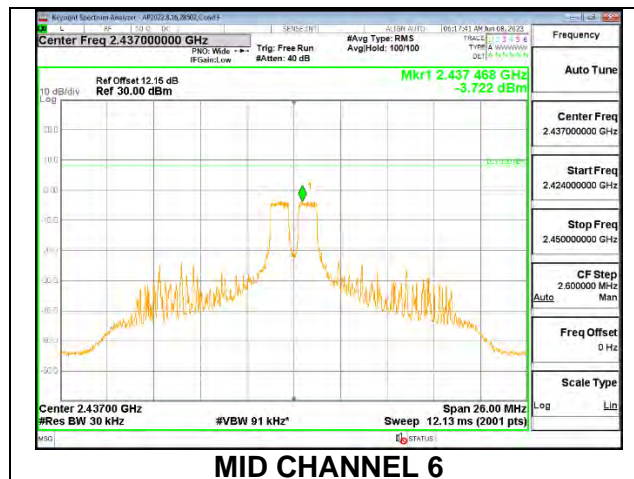

1TX ANT 3 MODE , 26-Tone RU Index 8

Duty Cycle CF (dB)		0.00	Included in Calculations of Corr'd PSD		
Channel	Frequency (MHz)	Meas (dBm/ 3kHz)	Total Corr'd PSD (dBm/ 3kHz)	Limit (dBm/ 3kHz)	Margin (dB)
Low 1	2412	-3.418	-3.418	8.0	-11.4
Mid 6	2437	-3.607	-3.607	8.0	-11.6
High 11	2462	-3.500	-3.500	8.0	-11.5
High 12	2467	-3.682	-3.682	8.0	-11.7
High 13	2472	-16.099	-16.099	8.0	-24.1

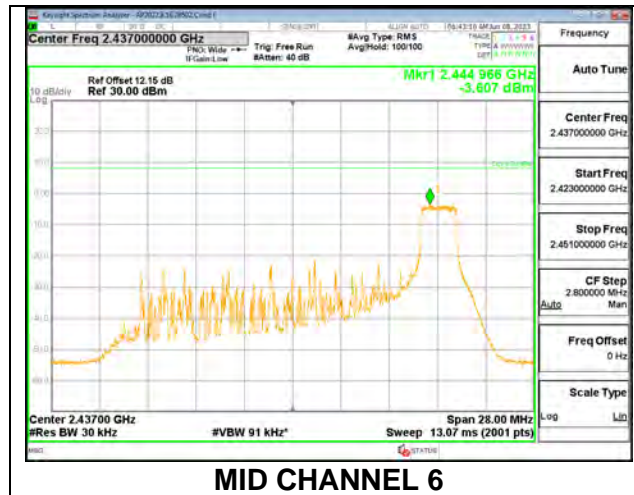

1TX ANT 3 MODE , SU Mode

Duty Cycle CF (dB)		0.00	Included in Calculations of Corr'd PSD		
Channel	Frequency (MHz)	Meas (dBm/ 3kHz)	Total Corr'd PSD (dBm/ 3kHz)	Limit (dBm/ 3kHz)	Margin (dB)
Low 1	2412	-8.660	-8.660	8.0	-16.7
Low 2	2417	-7.358	-7.358	8.0	-15.4
Low 3	2422	-3.733	-3.733	8.0	-11.7
Mid 6	2437	-3.729	-3.729	8.0	-11.7
High 9	2452	-4.192	-4.192	8.0	-12.2
High 10	2457	-7.421	-7.421	8.0	-15.4
High 11	2462	-8.224	-8.224	8.0	-16.2
High 12	2467	-10.411	-10.411	8.0	-18.4
High 13	2472	-15.762	-15.762	8.0	-23.8

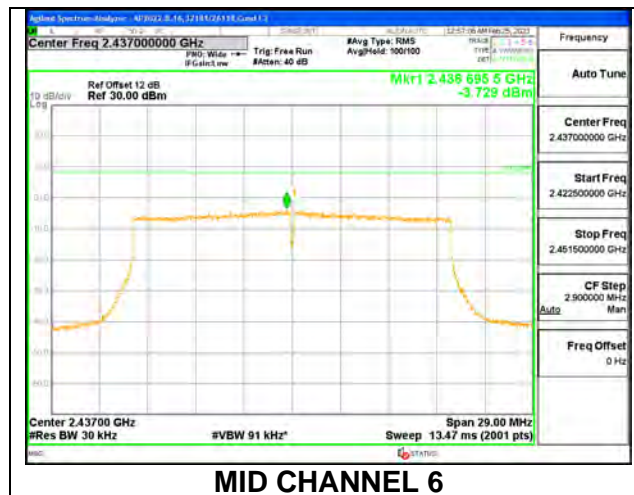

9.5.5. 802.11ax HE20 OFDMA MODE 2TX

ANT 4 + ANT 3 2TX MODE: 26-Tones, RU Index 0

Duty Cycle CF (dB)		0.00		Included in Calculations of Corr'd PSD		
Channel	Frequency (MHz)	ANT4 Meas (dBm/ 3kHz)	ANT3 Meas (dBm/ 3kHz)	Total Corr'd PSD (dBm/ 3kHz)	Limit (dBm/ 3kHz)	Margin (dB)
Low 1	2412	-3.613	-3.531	-0.562	8.0	-8.6
Mid 6	2437	-3.602	-3.630	-0.606	8.0	-8.6
High 11	2462	-3.614	-3.710	-0.651	8.0	-8.7
High 12	2467	-4.121	-4.183	-1.142	8.0	-9.1
High 13	2472	-15.961	-16.067	-13.003	8.0	-21.0

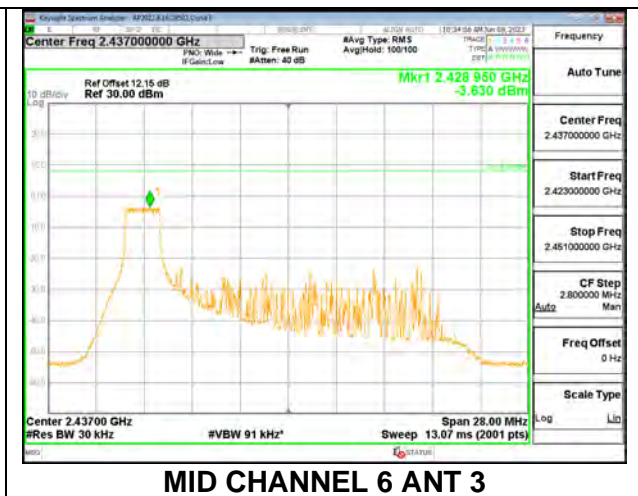
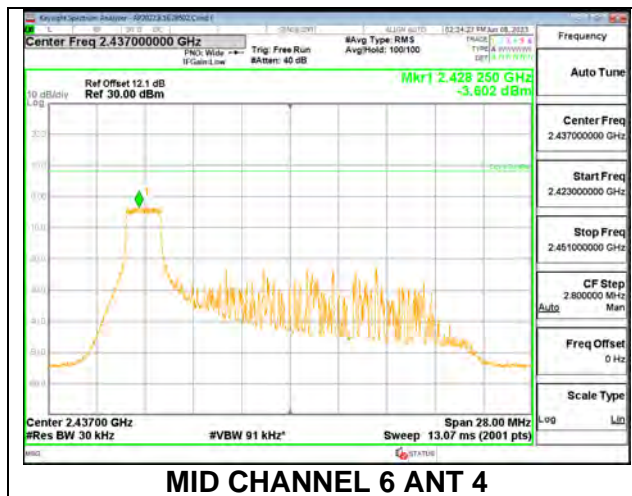

ANT 4 + ANT 3 2TX MODE: 26-Tones, RU Index 4

Duty Cycle CF (dB)		Included in Calculations of Corr'd PSD				
Channel	Frequency (MHz)	ANT4 Meas (dBm/ 3kHz)	ANT3 Meas (dBm/ 3kHz)	Total Corr'd PSD (dBm/ 3kHz)	Limit (dBm/ 3kHz)	Margin (dB)
Low 1	2412	-3.755	-3.592	-0.662	8.0	-8.7
Mid 6	2437	-3.609	-3.610	-0.599	8.0	-8.6
High 11	2462	-3.551	-3.455	-0.492	8.0	-8.5
High 12	2467	-4.203	-4.138	-1.160	8.0	-9.2
High 13	2472	-15.978	-16.137	-13.046	8.0	-21.0

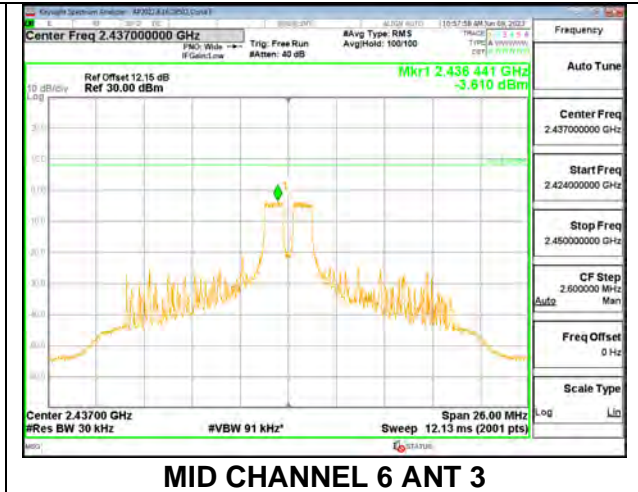
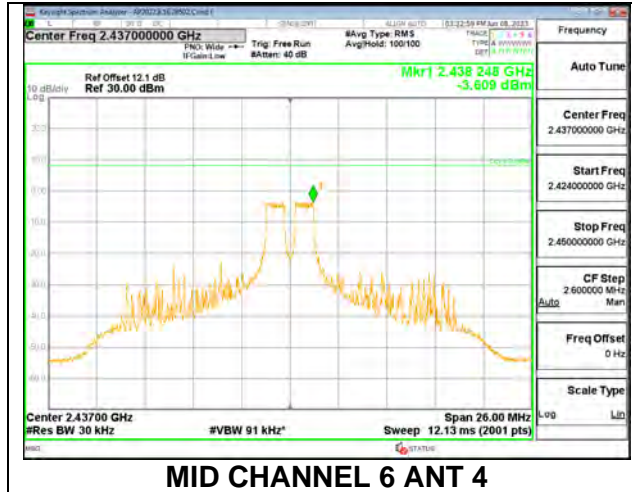

ANT 4 + ANT 3 2TX MODE: 26-Tones, RU Index 8

Duty Cycle CF (dB)		Included in Calculations of Corr'd PSD				
Channel	Frequency (MHz)	ANT4 Meas (dBm/ 3kHz)	ANT3 Meas (dBm/ 3kHz)	Total Corr'd PSD (dBm/ 3kHz)	Limit (dBm/ 3kHz)	Margin (dB)
Low 1	2412	-3.626	-3.738	-0.671	8.0	-8.7
Mid 6	2437	-3.804	-3.511	-0.645	8.0	-8.6
High 11	2462	-3.552	-3.823	-0.675	8.0	-8.7
High 12	2467	-4.048	-4.077	-1.052	8.0	-9.1
High 13	2472	-16.681	-16.912	-13.785	8.0	-21.8

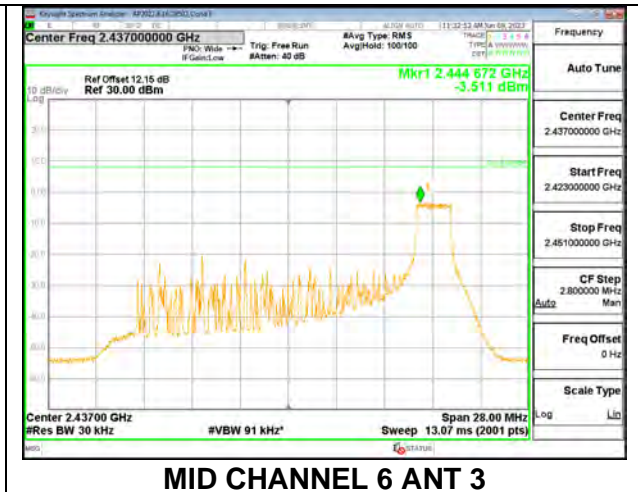
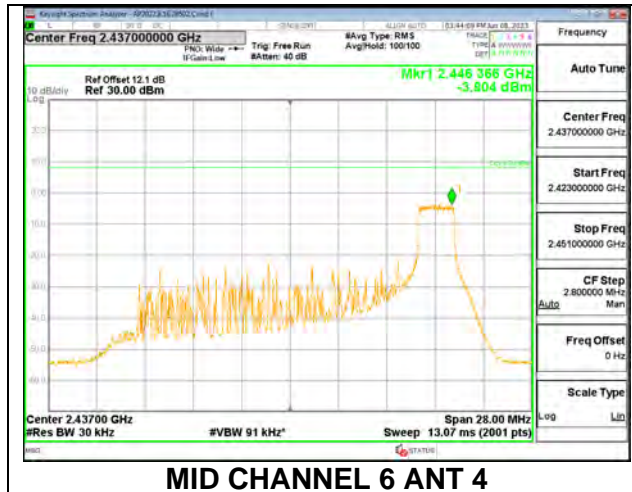

ANT 4 + ANT 3 2TX MODE: SU Mode

Duty Cycle CF (dB)		0.00		Included in Calculations of Corr'd PSD		
Channel	Frequency (MHz)	ANT 4 Meas (dBm/ 3kHz)	ANT 3 Meas (dBm/ 3kHz)	Total Corr'd PSD (dBm/ 3kHz)	Limit (dBm/ 3kHz)	Margin (dB)
Low 1	2412	-9.560	-9.122	-6.325	8.0	-14.3
Low 2	2417	-8.181	-8.237	-5.199	8.0	-13.2
Low 3	2422	-6.364	-6.165	-3.253	8.0	-11.3
Low 4	2427	-4.066	-3.663	-0.850	8.0	-8.8
Mid 6	2437	-3.880	-3.974	-0.916	8.0	-8.9
High 8	2447	-3.803	-3.750	-0.766	8.0	-8.8
High 9	2452	-6.849	-7.172	-3.997	8.0	-12.0
High 10	2457	-8.155	-8.062	-5.098	8.0	-13.1
High 11	2462	-9.405	-9.033	-6.205	8.0	-14.2
High 12	2467	-11.536	-10.953	-8.224	8.0	-16.2
High 13	2472	-16.372	-16.705	-13.525	8.0	-21.5

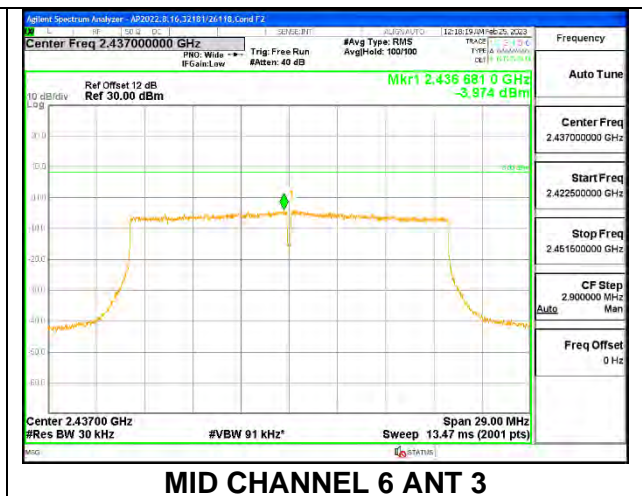
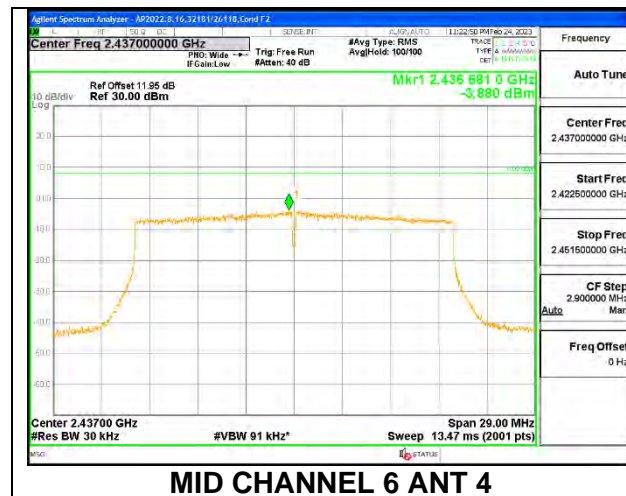

9.6. CONDUCTED SPURIOUS EMISSIONS

LIMITS

FCC §15.247 (d)

RSS-247 5.5

In any 100 kHz bandwidth outside the frequency band in which the spread spectrum or digitally modulated intentional radiator is operating, the radio frequency power that is produced by the intentional radiator shall be at least 20 dB below that in the 100 kHz bandwidth within the band that contains the highest level of the desired power, based on either an RF conducted or a radiated measurement, provided the transmitter demonstrates compliance with the peak conducted power limits. If the transmitter complies with the conducted power limits based on the use of RMS averaging over a time interval, as permitted under paragraph (b)(3) of this section, the attenuation required under this paragraph shall be 30 dB instead of 20 dB. Attenuation below the general limits specified in §15.209(a) is not required. In addition, radiated emissions which fall in the restricted bands, as defined in §15.205(a), must also comply with the radiated emission limits specified in §15.209(a) (see §15.205(c)).

RESULTS

9.6.1. 802.11b MODE 1TX

1TX ANT 4 MODE



LOW CHANNEL 1 BANDEDGE



OUT-OF-BAND LOW CHANNEL 1

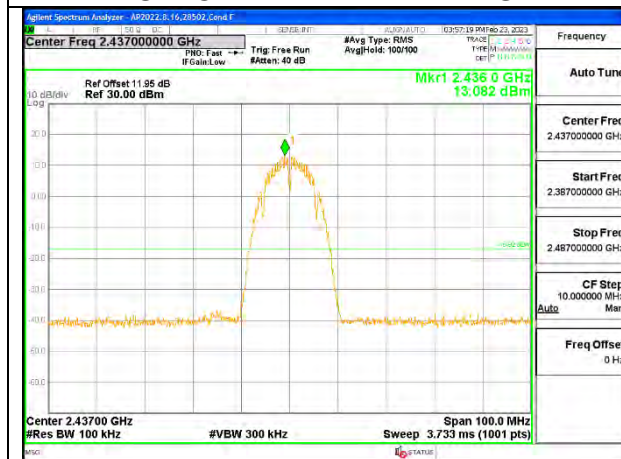

IN-BAND REFERENCE LEVEL



OUT-OF-BAND MID CHANNEL

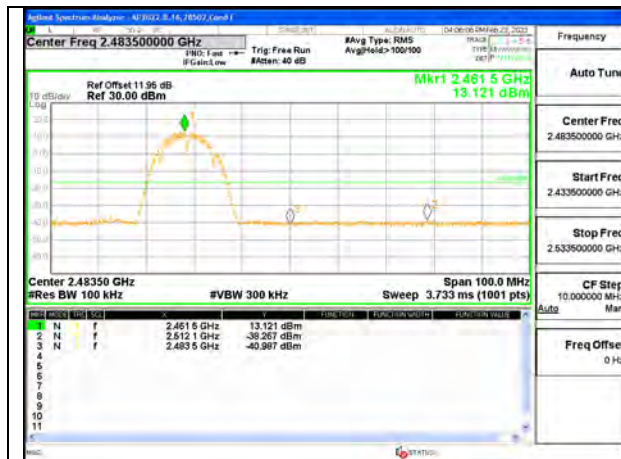

HIGH CHANNEL 11 BANDEDGE



OUT-OF-BAND HIGH CHANNEL 11

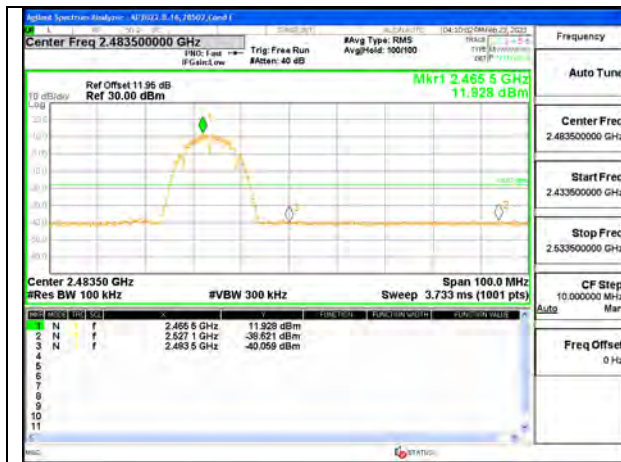

HIGH CHANNEL 12 BANDEDGE



OUT-OF-BAND HIGH CHANNEL 12



HIGH CHANNEL 13 BANDEDGE



OUT-OF-BAND HIGH CHANNEL 13

1TX ANT 3 MODE



LOW CHANNEL 1 BANDEDGE



OUT-OF-BAND LOW CHANNEL 1

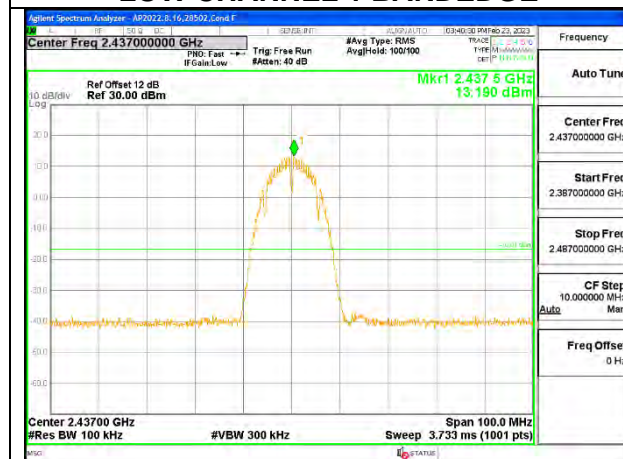

IN-BAND REFERENCE LEVEL



OUT-OF-BAND MID CHANNEL

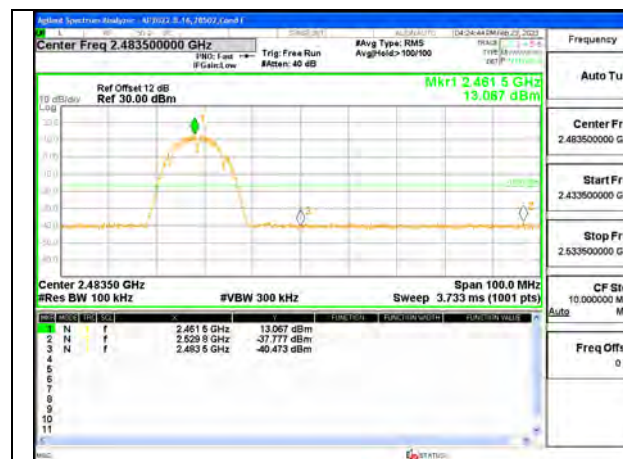

HIGH CHANNEL 11 BANDEDGE

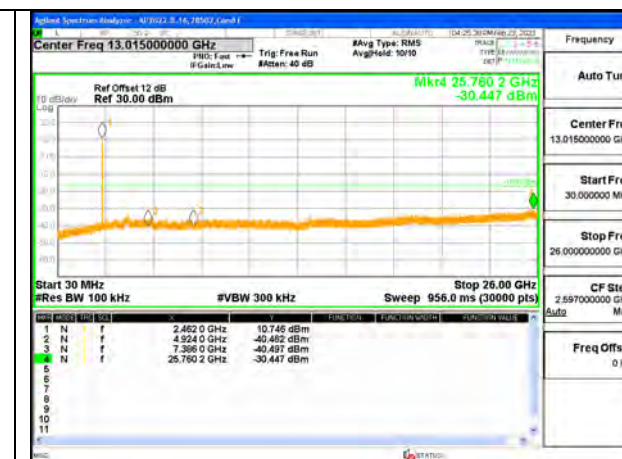

OUT-OF-BAND HIGH CHANNEL 11



HIGH CHANNEL 12 BANDEDGE



OUT-OF-BAND HIGH CHANNEL 12



HIGH CHANNEL 13 BANDEDGE



OUT-OF-BAND HIGH CHANNEL 13

9.6.2. 802.11n HT20 SISO MODE

1TX ANT 4 MODE



LOW CHANNEL 1 BANDEDGE



OUT-OF-BAND LOW CHANNEL 1

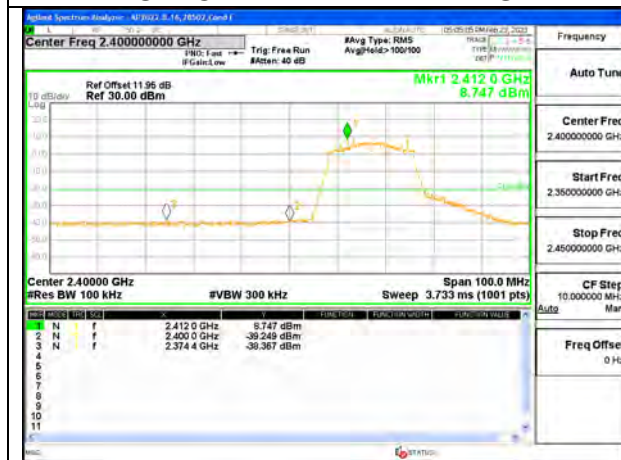

LOW CHANNEL 2 BANDEDGE



OUT-OF-BAND LOW CHANNEL 2



LOW CHANNEL 3 BANDEDGE



OUT-OF-BAND LOW CHANNEL 3

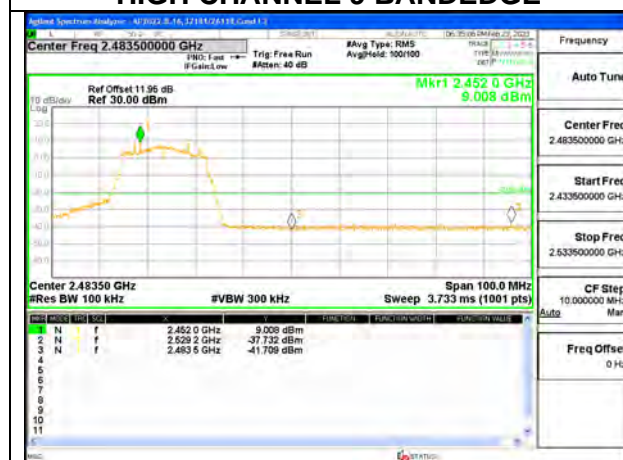



HIGH CHANNEL 11 BANDEDGE



OUT-OF-BAND HIGH CHANNEL 11



HIGH CHANNEL 12 BANDEDGE



OUT-OF-BAND HIGH CHANNEL 12



HIGH CHANNEL 13 BANDEDGE



OUT OF-BAND HIGH CHANNEL 13

1TX ANT 3 MODE



LOW CHANNEL 1 BANDEDGE



OUT-OF-BAND LOW CHANNEL 1



LOW CHANNEL 2 BANDEDGE



OUT-OF-BAND LOW CHANNEL 2



LOW CHANNEL 3 BANDEDGE



OUT-OF-BAND LOW CHANNEL 3

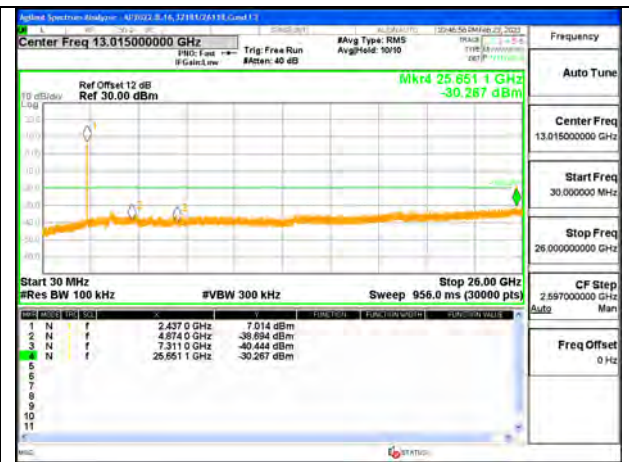
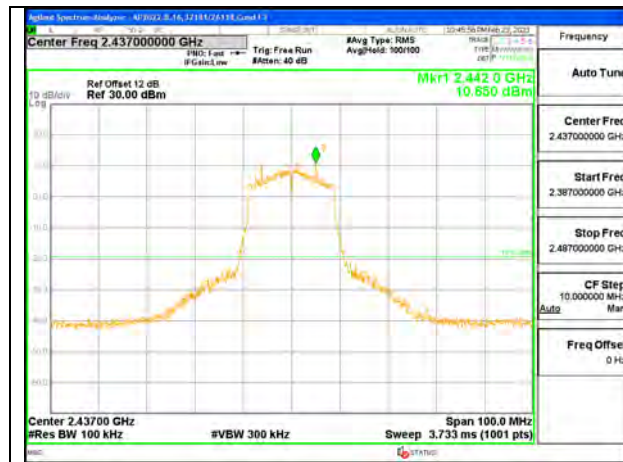



HIGH CHANNEL 11 BANDEDGE



OUT-OF-BAND HIGH CHANNEL 11



HIGH CHANNEL 12 BANDEDGE



OUT-OF-BAND HIGH CHANNEL 12



HIGH CHANNEL 13 BANDEDGE



OUT-OF-BAND HIGH CHANNEL 13

9.6.3. 802.11n HT20 MODE 2TX

2TX ANT 4 + ANT 3 CDD MODE



LOW CHANNEL 1 BANDEDGE ANT 4



OUT-OF-BAND LOW CHANNEL 1 ANT 4

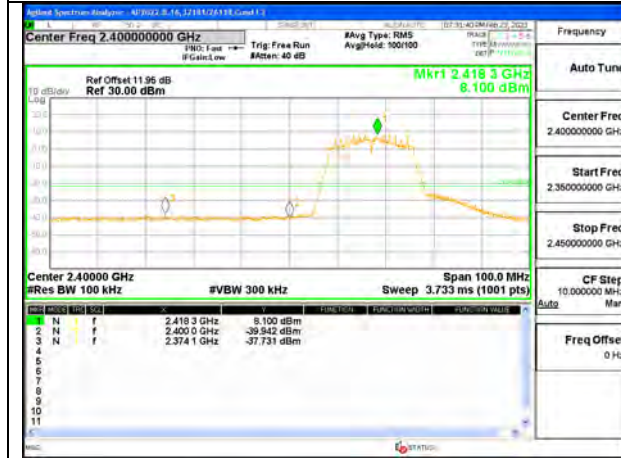

LOW CHANNEL 2 BANDEDGE ANT 4



OUT-OF-BAND LOW CHANNEL 2 ANT 4



LOW CHANNEL 3 BANDEDGE ANT 4



OUT-OF-BAND LOW CHANNEL 3 ANT 4



LOW CHANNEL 4 BANDEDGE ANT 4



OUT-OF-BAND LOW CHANNEL 4 ANT 4



IN-BAND REFERENCE LEVEL ANT 4



OUT-OF-BAND MID CHANNEL ANT 4



HIGH CHANNEL 8 BANDEDGE ANT 4



OUT-OF-BAND HIGH CHANNEL 8 ANT 4



HIGH CHANNEL 9 BANDEDGE ANT 4



OUT-OF-BAND HIGH CHANNEL 9 ANT 4

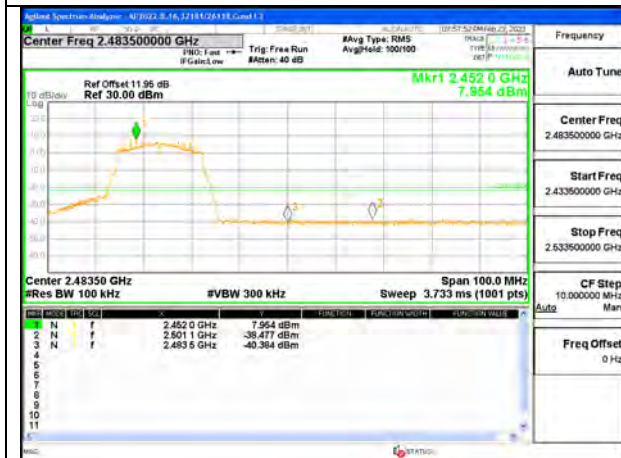

HIGH CHANNEL 10 BANDEDGE ANT 4



OUT-OF-BAND HIGH CHANNEL 10 ANT 4



HIGH CHANNEL 11 BANDEDGE ANT 4



OUT-OF-BAND HIGH CHANNEL 11 ANT 4



HIGH CHANNEL 12 BANDEDGE ANT 4



OUT-OF-BAND HIGH CHANNEL 12 ANT 4



HIGH CHANNEL 13 BANDEDGE ANT 4



OUT-OF-BAND HIGH CHANNEL 13 ANT 4



LOW CHANNEL 1 BANDEDGE ANT 3



OUT-OF-BAND LOW CHANNEL 1 ANT 3



LOW CHANNEL 2 BANDEDGE ANT 3



OUT-OF-BAND LOW CHANNEL 2 ANT 3



LOW CHANNEL 3 BANDEDGE ANT 3



OUT-OF-BAND LOW CHANNEL 3 ANT 3



LOW CHANNEL 4 BANDEDGE ANT 3



OUT-OF-BAND LOW CHANNEL 4 ANT 3



IN-BAND REFERENCE LEVEL ANT 3



OUT-OF-BAND MID CHANNEL ANT 3



HIGH CHANNEL 8 BANDEDGE ANT 3



OUT-OF-BAND HIGH CHANNEL 8 ANT 3



HIGH CHANNEL 9 BANDEDGE ANT 3



OUT-OF-BAND HIGH CHANNEL 9 ANT 3



HIGH CHANNEL 10 BANDEDGE ANT 3



OUT-OF-BAND HIGH CHANNEL 10 ANT 3

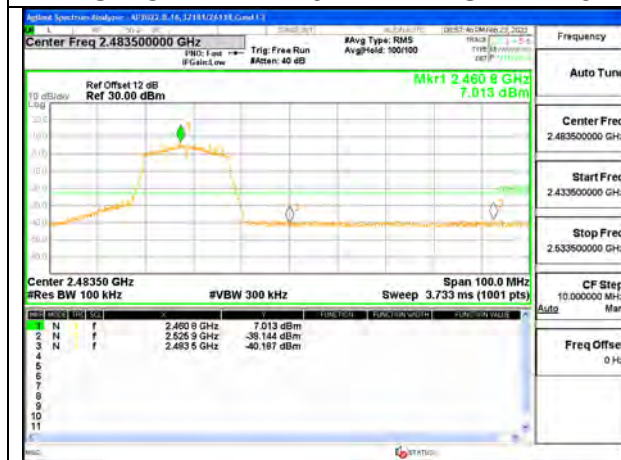

HIGH CHANNEL 11 BANDEDGE ANT 3



OUT-OF-BAND HIGH CHANNEL 11 ANT 3



HIGH CHANNEL 12 BANDEDGE ANT 3



OUT-OF-BAND HIGH CHANNEL 12 ANT 3



HIGH CHANNEL 13 BANDEDGE ANT 3



OUT-OF-BAND HIGH CHANNEL 13 ANT 3

9.6.4. 802.11ax HE20 MODE
1TX ANT 4 MODE, 26-Tone RU Index 0

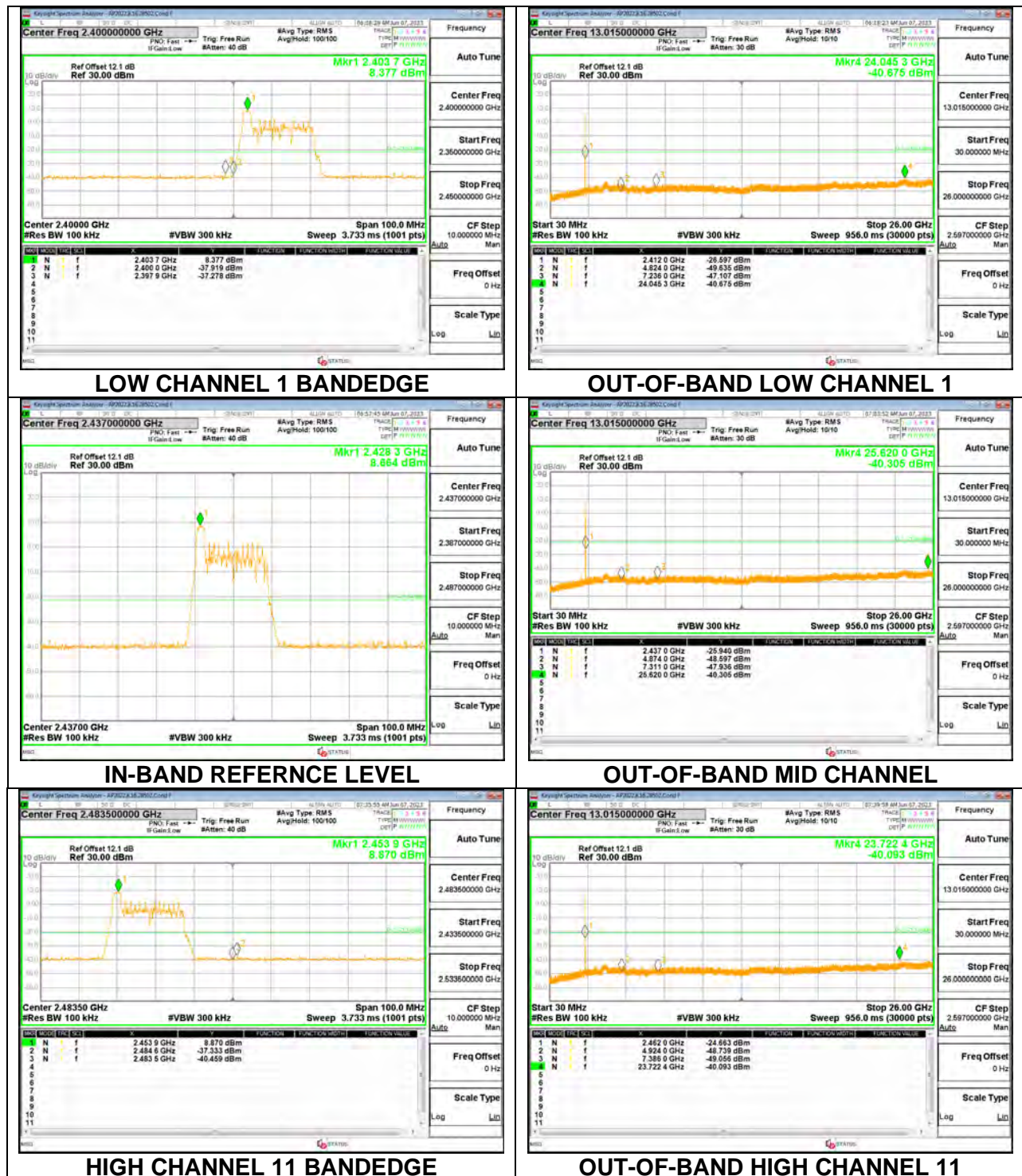



HIGH CHANNEL 12 BANDEDGE



OUT-OF-BAND HIGH CHANNEL 12



HIGH CHANNEL 13 BANDEDGE



OUT-OF-BAND HIGH CHANNEL 13

1TX ANT 4 MODE, 26-Tone RU Index 4



LOW CHANNEL 1 BANDEDGE



OUT-OF-BAND LOW CHANNEL 1

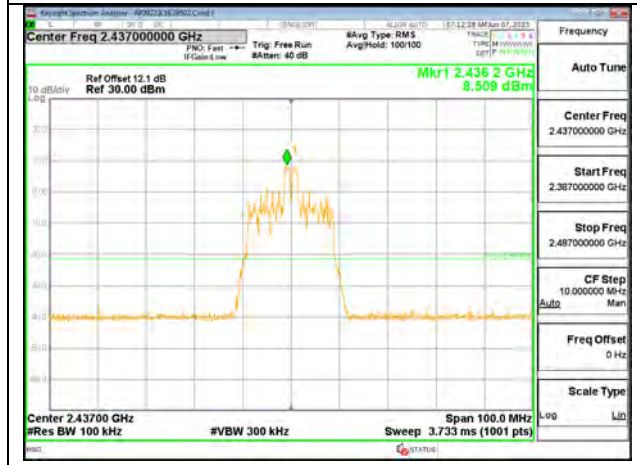

IN-BAND REFERENCE LEVEL



OUT-OF-BAND MID CHANNEL



HIGH CHANNEL 11 BANDEDGE



OUT-OF-BAND HIGH CHANNEL 11



HIGH CHANNEL 12 BANDEDGE



OUT-OF-BAND HIGH CHANNEL 12



HIGH CHANNEL 13 BANDEDGE



OUT-OF-BAND HIGH CHANNEL 13

1TX ANT 4 MODE, 26-Tone RU Index 8

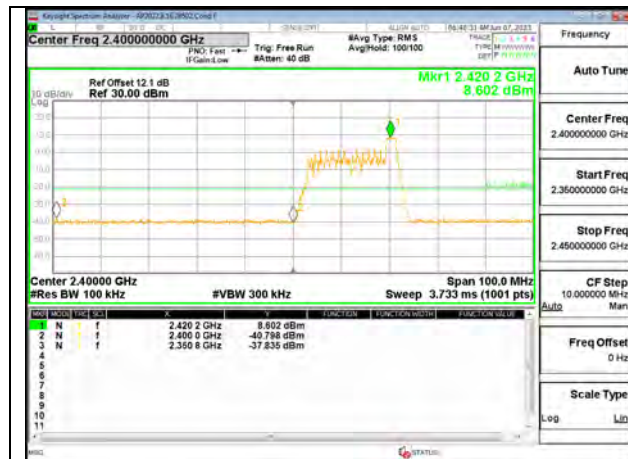

LOW CHANNEL 1 BANDEDGE



OUT-OF-BAND LOW CHANNEL 1



IN-BAND REFERENCE LEVEL



OUT-OF-BAND MID CHANNEL



HIGH CHANNEL 11 BANDEDGE



OUT-OF-BAND HIGH CHANNEL 11



HIGH CHANNEL 12 BANDEDGE



OUT-OF-BAND HIGH CHANNEL 12

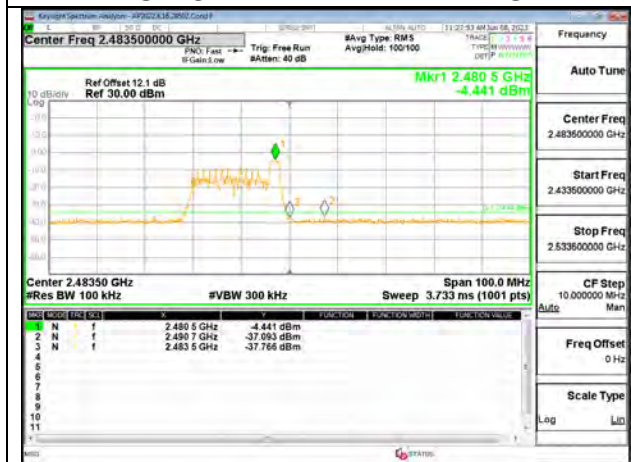

HIGH CHANNEL 13 BANDEDGE



OUT-OF-BAND HIGH CHANNEL 13

1TX ANT 4 MODE, SU Mode



LOW CHANNEL 1 BANDEDGE



OUT-OF-BAND LOW CHANNEL 1



LOW CHANNEL 2 BANDEDGE



OUT-OF-BAND LOW CHANNEL 2



LOW CHANNEL 3 BANDEDGE



OUT-OF-BAND LOW CHANNEL 3

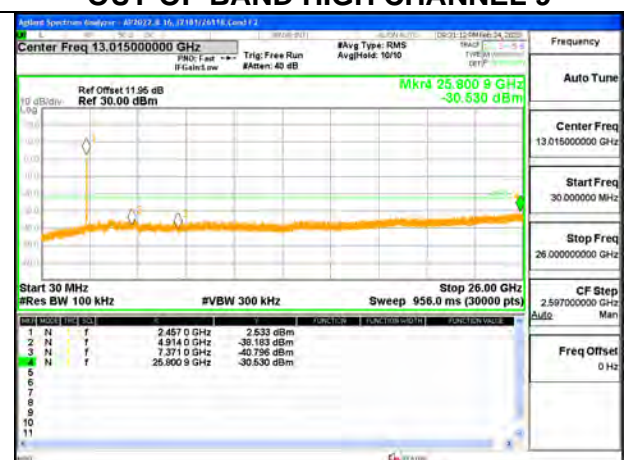
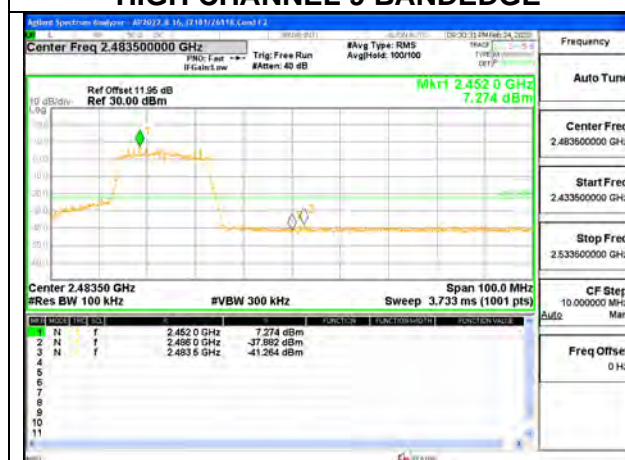
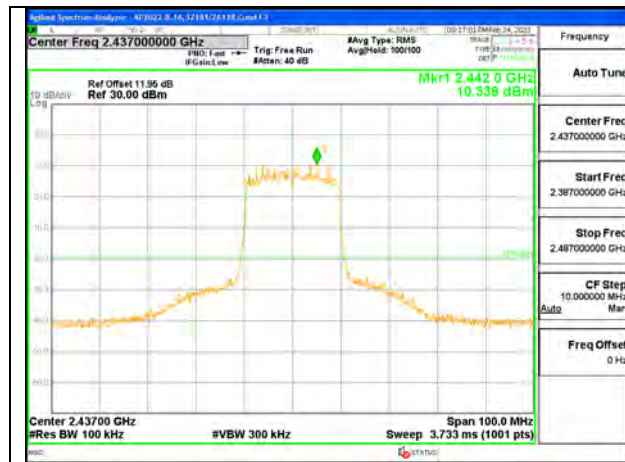



HIGH CHANNEL 11 BANDEDGE



OUT-OF-BAND HIGH CHANNEL 11



HIGH CHANNEL 12 BANDEDGE



OUT-OF-BAND HIGH CHANNEL 12



HIGH CHANNEL 13 BANDEDGE



OUT-OF-BAND HIGH CHANNEL 13

1TX ANT 3 MODE, 26-Tone RU Index 0



LOW CHANNEL 1 BANDEDGE

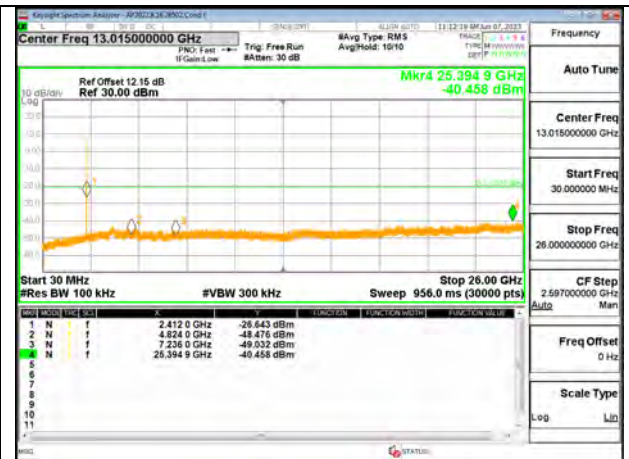

OUT-OF-BAND LOW CHANNEL 1



IN-BAND REFERENCE LEVEL

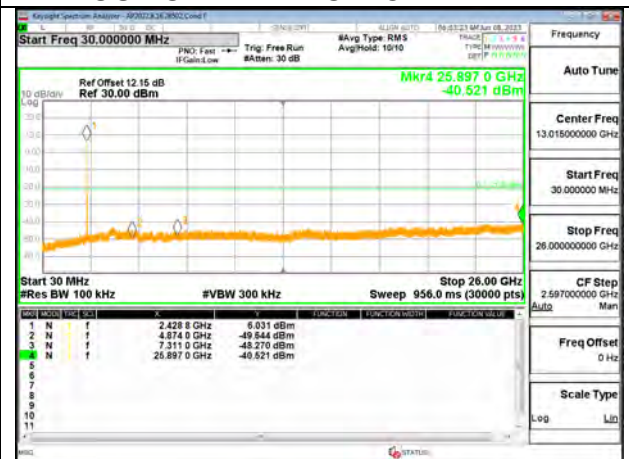

OUT-OF-BAND MID CHANNEL



HIGH CHANNEL 11 BANDEDGE



OUT-OF-BAND HIGH CHANNEL 11



HIGH CHANNEL 12 BANDEDGE



OUT-OF-BAND HIGH CHANNEL 12



HIGH CHANNEL 13 BANDEDGE



OUT-OF-BAND HIGH CHANNEL 13

1TX ANT 3 MODE, 26-Tone RU Index 4

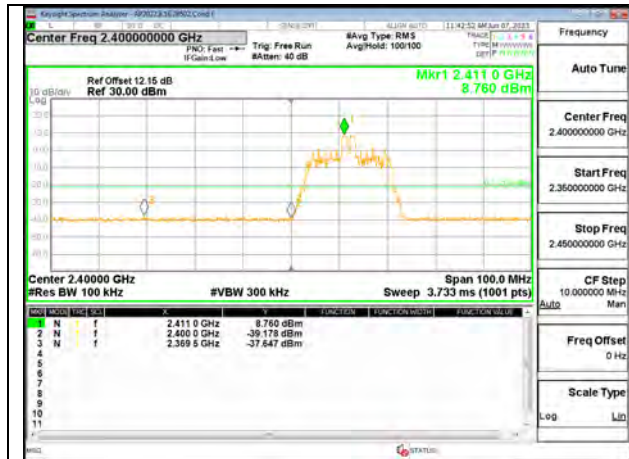

LOW CHANNEL 1 BANDEDGE



OUT-OF-BAND LOW CHANNEL 1



IN-BAND REFERENCE LEVEL



OUT-OF-BAND MID CHANNEL

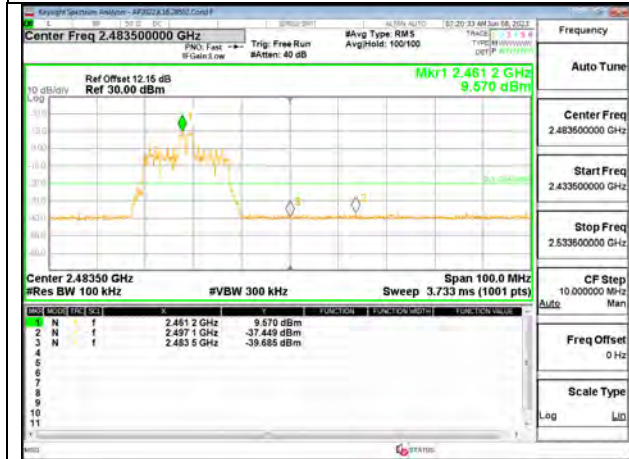

HIGH CHANNEL 11 BANDEDGE

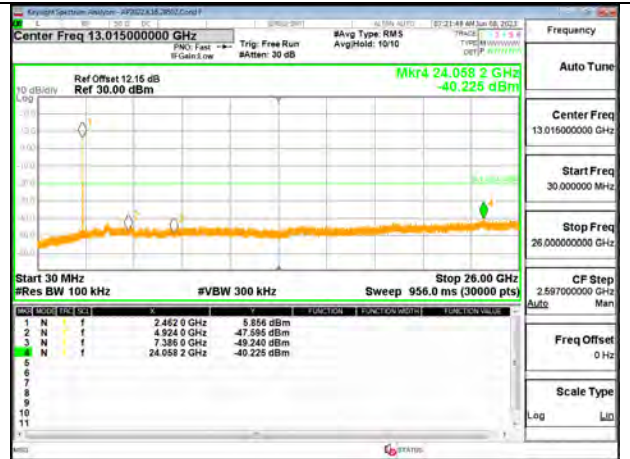

OUT-OF-BAND HIGH CHANNEL 11



HIGH CHANNEL 12 BANDEDGE

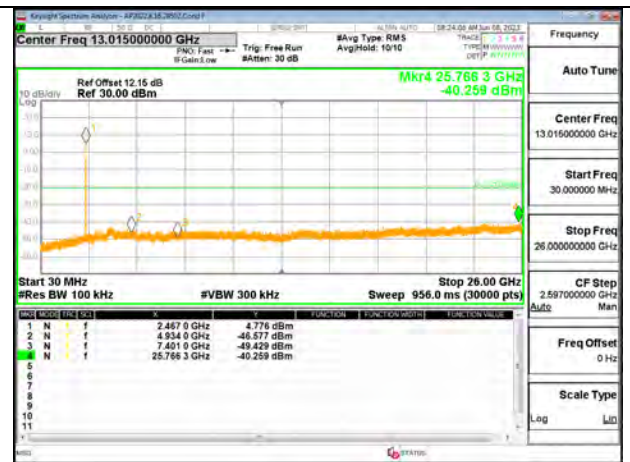

OUT-OF-BAND HIGH CHANNEL 12



HIGH CHANNEL 13 BANDEDGE



OUT-OF-BAND HIGH CHANNEL 13

1TX ANT 3 MODE, 26-Tone RU Index 8



LOW CHANNEL 1 BANDEDGE



OUT-OF-BAND LOW CHANNEL 1

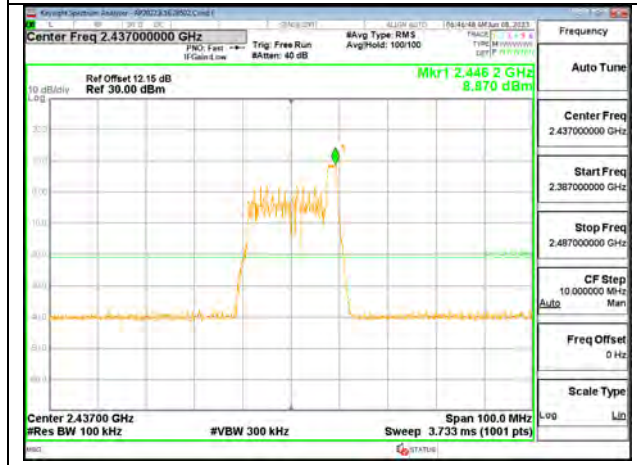

IN-BAND REFERENCE LEVEL



OUT-OF-BAND MID CHANNEL



HIGH CHANNEL 11 BANDEDGE

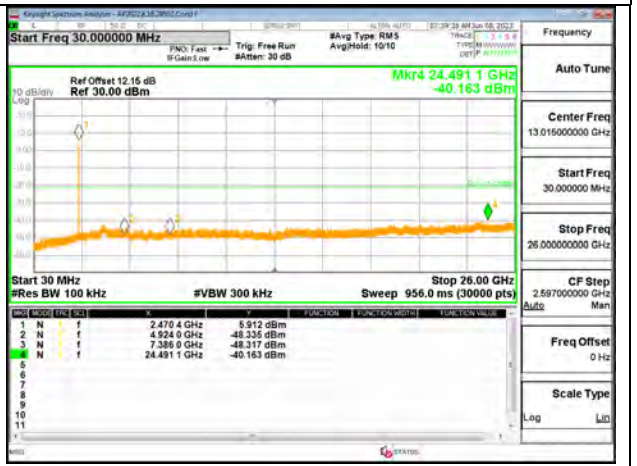

OUT-OF-BAND HIGH CHANNEL 11



HIGH CHANNEL 12 BANDEDGE



OUT-OF-BAND HIGH CHANNEL 12



HIGH CHANNEL 13 BANDEDGE



OUT-OF-BAND HIGH CHANNEL 13