

HAC-RF Emission System Check

Communication System: UID 0, CW; Frequency: 835 MHz; Duty Cycle: 1:1
 Phantom section: RF Section
 DASY5 Configuration:
 - Probe: EF3DV3 - SN4041; ConvF(1, 1, 1) @ 835 MHz; Calibrated: 3/18/2020
 - Sensor-Surface: (Fix Surface)
 - Electronics: DAE4 Sn1357; Calibrated: 2/20/2020
 - Phantom: HAC Test Arch with AMCC; Type: SD HAC P01 BB
 - Measurement SW: DASY52, Version 52.10 (4);SEMCAD X Version 14.6.14 (7483)

Dipole E-Field measurement 835MHz/835 MHz/Hearing Aid Compatibility Test at 15mm distance (41x361x1):

Interpolated grid: dx=0.5000 mm, dy=0.5000 mm
 Device Reference Point: 0, 0, -6.3 mm
 Reference Value = 148.6 V/m; Power Drift = -0.27 dB
 Applied MIF = 0.00 dB
 RF audio interference level = 42.39 dBV/m

Emission category: **M3**

MIF scaled E-field

Grid 1 M4 40 dBV/m	Grid 2 M3 40.51 dBV/m	Grid 3 M3 40.49 dBV/m
Grid 4 M4 36.57 dBV/m	Grid 5 M4 36.81 dBV/m	Grid 6 M4 36.71 dBV/m
Grid 7 M3 42.03 dBV/m	Grid 8 M3 42.39 dBV/m	Grid 9 M3 42.33 dBV/m

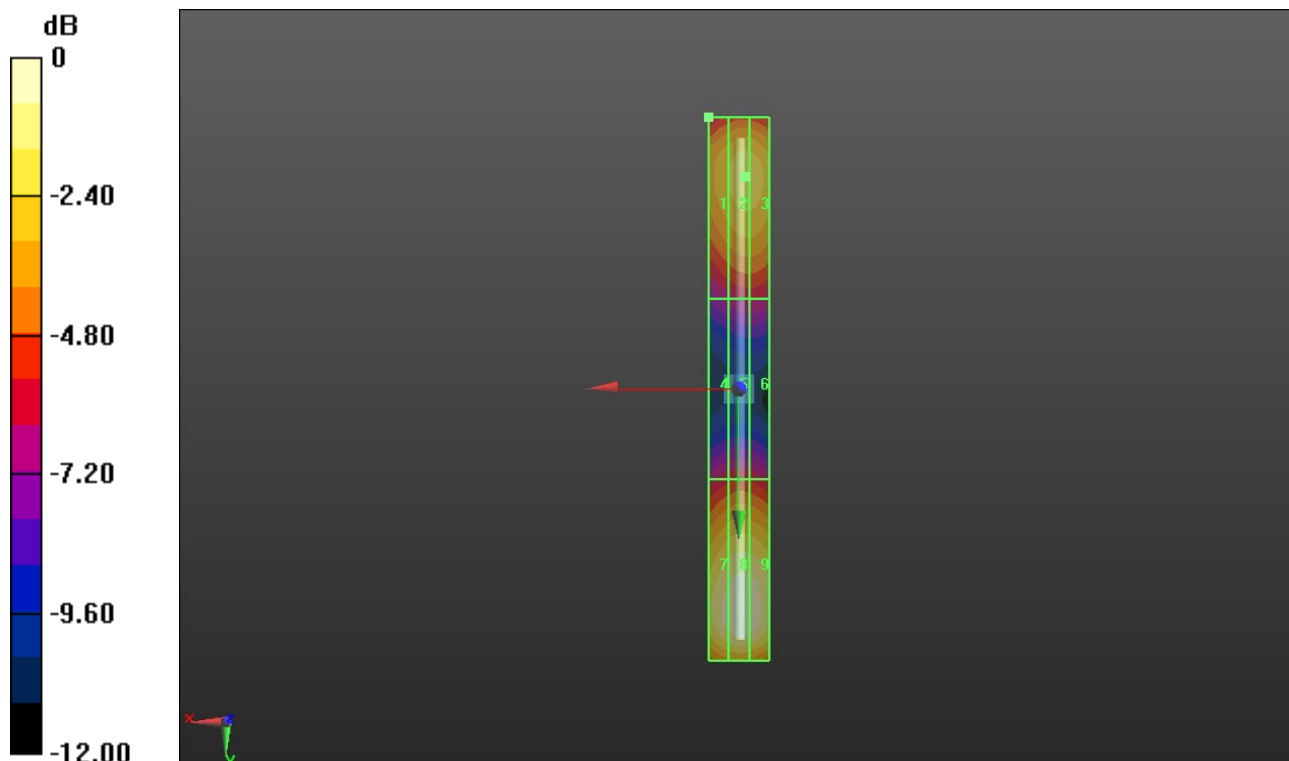

0 dB = 131.7 V/m = 42.39 dBV/m

HAC-RF Emission System Check

Communication System: UID 0, CW; Frequency: 1880 MHz; Duty Cycle: 1:1

Phantom section: RF Section

DASY5 Configuration:

- Probe: EF3DV3 - SN4041; ConvF(1, 1, 1) @ 1880 MHz; Calibrated: 3/18/2020
- Sensor-Surface: (Fix Surface)
- Electronics: DAE4 Sn1357; Calibrated: 2/20/2020
- Phantom: HAC Test Arch with AMCC; Type: SD HAC P01 BB
- Measurement SW: DASY52, Version 52.10 (4);SEMCAD X Version 14.6.14 (7483)

Dipole E-Field Measurement 1880MHz/1880 MHz/Hearing Aid Compatibility Test at 15mm distance (41x181x1): Interpolated grid: dx=0.5000 mm, dy=0.5000 mm

Device Reference Point: 0, 0, -6.3 mm

Reference Value = 162.2 V/m; Power Drift = -0.13 dB

Applied MIF = 0.00 dB

RF audio interference level = 39.93 dBV/m

Emission category: **M2**

MIF scaled E-field

Grid 1 M2 39.26 dBV/m	Grid 2 M2 39.62 dBV/m	Grid 3 M2 39.57 dBV/m
Grid 4 M2 36.6 dBV/m	Grid 5 M2 36.79 dBV/m	Grid 6 M2 36.76 dBV/m
Grid 7 M2 39.55 dBV/m	Grid 8 M2 39.93 dBV/m	Grid 9 M2 39.86 dBV/m

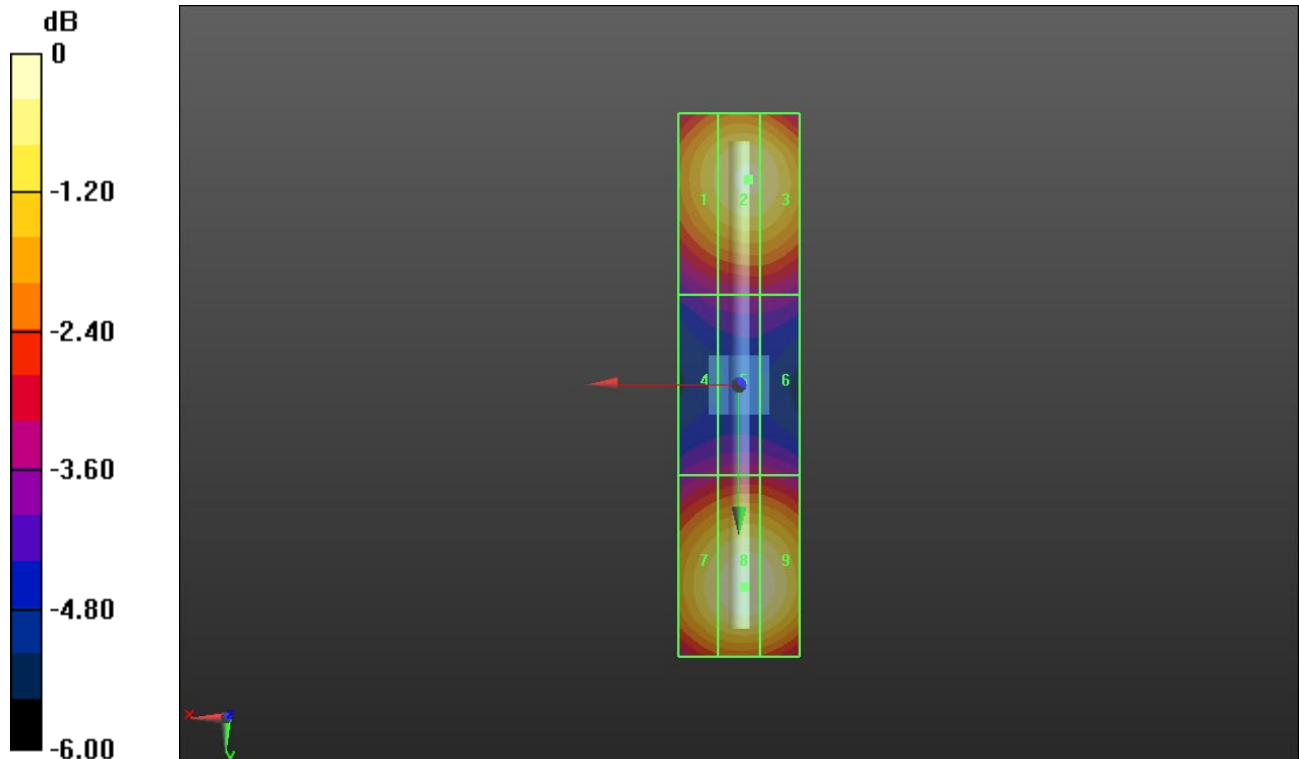

0 dB = 99.20 V/m = 39.93 dBV/m

HAC-RF Emission System Check

Communication System: UID 0, CW (0); Frequency: 2450 MHz; Duty Cycle: 1:1

Phantom section: RF Section

DASY5 Configuration:

- Probe: EF3DV3 - SN4041; ConvF(1, 1, 1) @ 2450 MHz; Calibrated: 3/18/2020
- Sensor-Surface: (Fix Surface)
- Electronics: DAE4 Sn1357; Calibrated: 2/20/2020
- Phantom: HAC Test Arch with AMCC; Type: SD HAC P01 BB
- Measurement SW: DASY52, Version 52.10 (4);SEMCAD X Version 14.6.14 (7483)

Dipole E-Field Measurement 2450MHz/2450 MHz/Hearing Aid Compatibility Test at 15mm distance (41x181x1): Interpolated grid: dx=0.5000 mm, dy=0.5000 mm

Device Reference Point: 0, 0, -6.3 mm

Reference Value = 74.49 V/m; Power Drift = 0.43 dB

Applied MIF = 0.00 dB

RF audio interference level = 39.57 dBV/m

Emission category: **M2**

MIF scaled E-field

Grid 1 M2 39.11 dBV/m	Grid 2 M2 39.57 dBV/m	Grid 3 M2 39.51 dBV/m
Grid 4 M2 37.93 dBV/m	Grid 5 M2 38.31 dBV/m	Grid 6 M2 38.3 dBV/m
Grid 7 M2 38.85 dBV/m	Grid 8 M2 39.29 dBV/m	Grid 9 M2 39.22 dBV/m

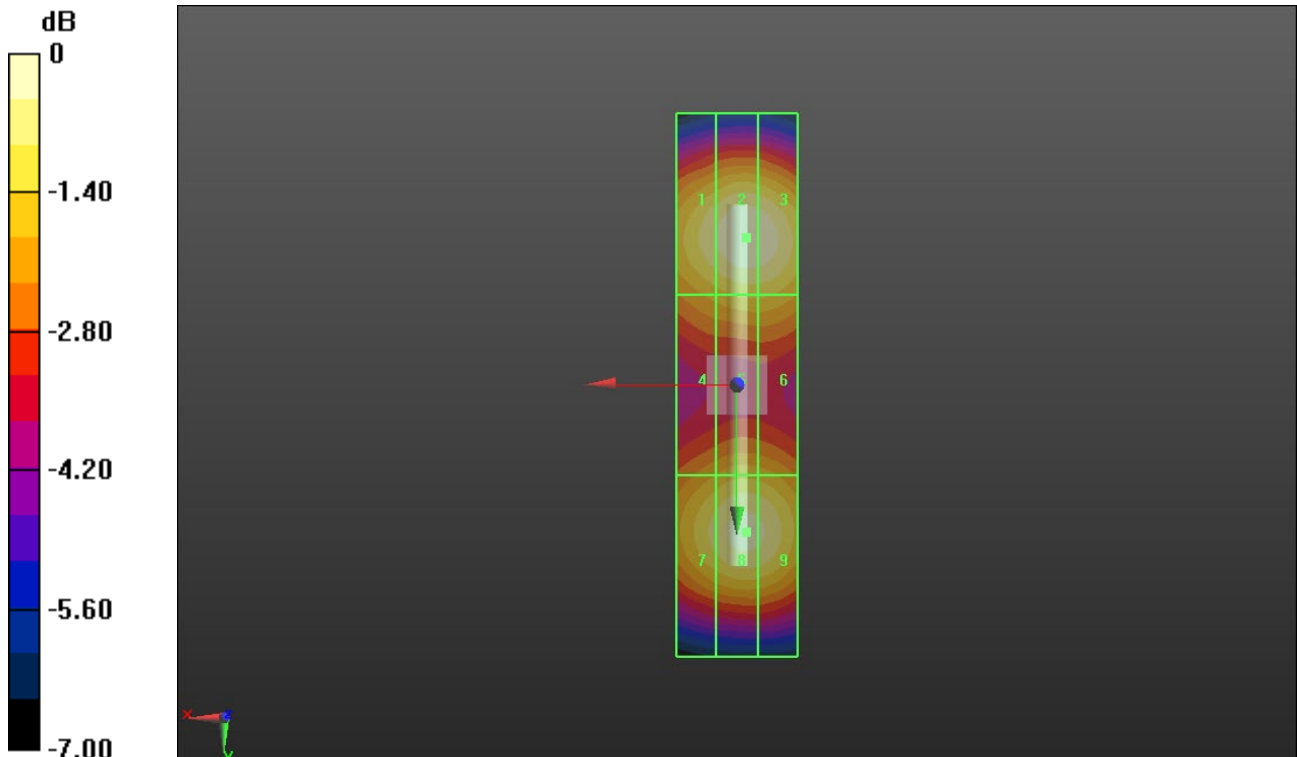

0 dB = 95.15 V/m = 39.57 dBV/m

HAC-RF Emission System Check

Communication System: UID 0, CW (0); Frequency: 2600 MHz; Duty Cycle: 1:1

Phantom section: RF Section

DASY5 Configuration:

- Probe: EF3DV3 - SN4041; ConvF(1, 1, 1) @ 2600 MHz; Calibrated: 3/18/2020
- Sensor-Surface: (Fix Surface)
- Electronics: DAE4 Sn1357; Calibrated: 2/20/2020
- Phantom: HAC Test Arch with AMCC; Type: SD HAC P01 BB
- Measurement SW: DASY52, Version 52.10 (4); SEMCAD X Version 14.6.14 (7483)

Dipole E-Field Measurement 2600MHz/2600 MHz/Hearing Aid Compatibility Test at 15mm distance (41x181x1): Interpolated grid: dx=0.5000 mm, dy=0.5000 mm

Device Reference Point: 0, 0, -6.3 mm

Reference Value = 68.37 V/m; Power Drift = -0.04 dB

Applied MIF = 0.00 dB

RF audio interference level = 39.31 dBV/m

Emission category: **M2**

MIF scaled E-field

Grid 1 M2 39.02 dBV/m	Grid 2 M2 39.3 dBV/m	Grid 3 M2 39.22 dBV/m
Grid 4 M2 38.4 dBV/m	Grid 5 M2 38.56 dBV/m	Grid 6 M2 38.49 dBV/m
Grid 7 M2 38.7 dBV/m	Grid 8 M2 39.07 dBV/m	Grid 9 M2 39.03 dBV/m

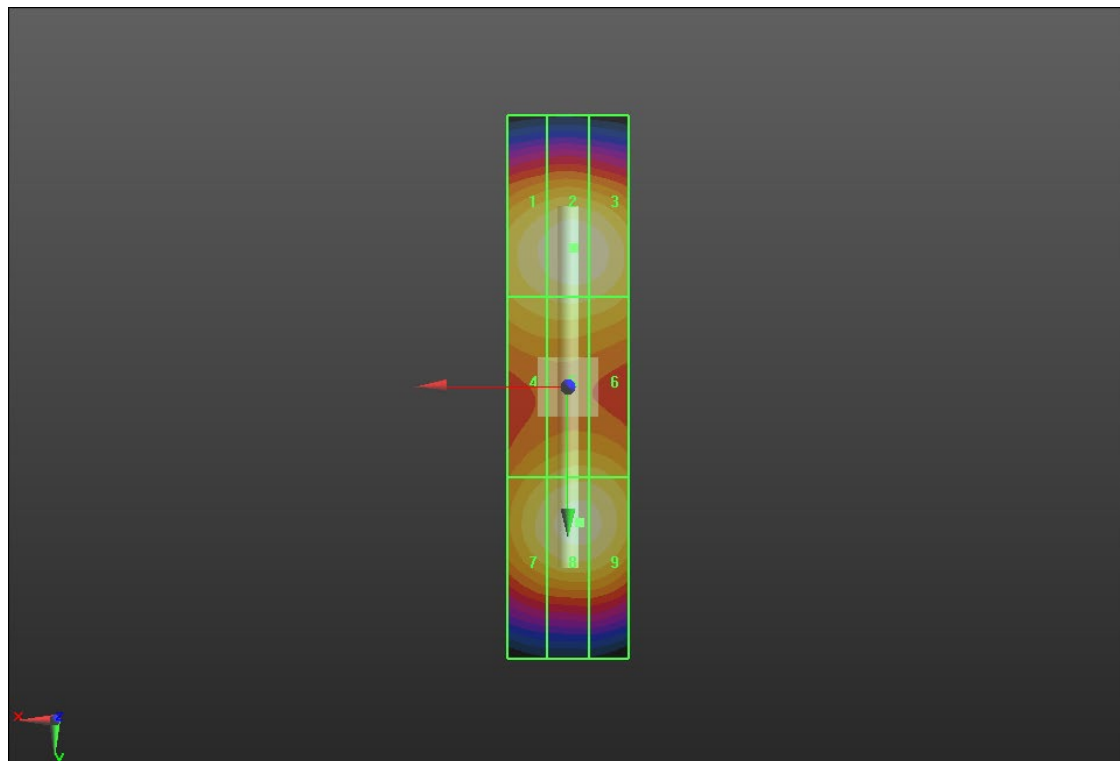
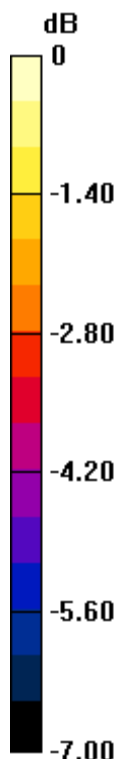

0 dB = 92.31 V/m = 39.30 dBV/m

HAC-RF Emission System Check

Communication System: UID 0, CW (0); Frequency: 3500 MHz; Duty Cycle: 1:1

Phantom section: RF Section

DASY5 Configuration:

- Probe: EF3DV3 - SN4041; ConvF(1, 1, 1) @ 3500 MHz; Calibrated: 3/18/2020
- Sensor-Surface: (Fix Surface)
- Electronics: DAE4 Sn1357; Calibrated: 2/20/2020
- Phantom: HAC Test Arch with AMCC; Type: SD HAC P01 BB
- Measurement SW: DASY52, Version 52.10 (4);SEMCAD X Version 14.6.14 (7483)

Dipole E-Field Measurement 3500MHz/3500 MHz/Hearing Aid Compatibility Test at 15mm distance (41x181x1): Interpolated grid: dx=0.5000 mm, dy=0.5000 mm

Device Reference Point: 0, 0, -6.3 mm

Reference Value = 36.20 V/m; Power Drift = 0.14 dB

Applied MIF = 0.00 dB

RF audio interference level = 39.32 dBV/m

Emission category: **M2**

MIF scaled E-field

Grid 1 M2 39.01 dBV/m	Grid 2 M2 39.27 dBV/m	Grid 3 M2 39.22 dBV/m
Grid 4 M2 39.01 dBV/m	Grid 5 M2 39.32 dBV/m	Grid 6 M2 39.23 dBV/m
Grid 7 M2 39 dBV/m	Grid 8 M2 39.32 dBV/m	Grid 9 M2 39.23 dBV/m

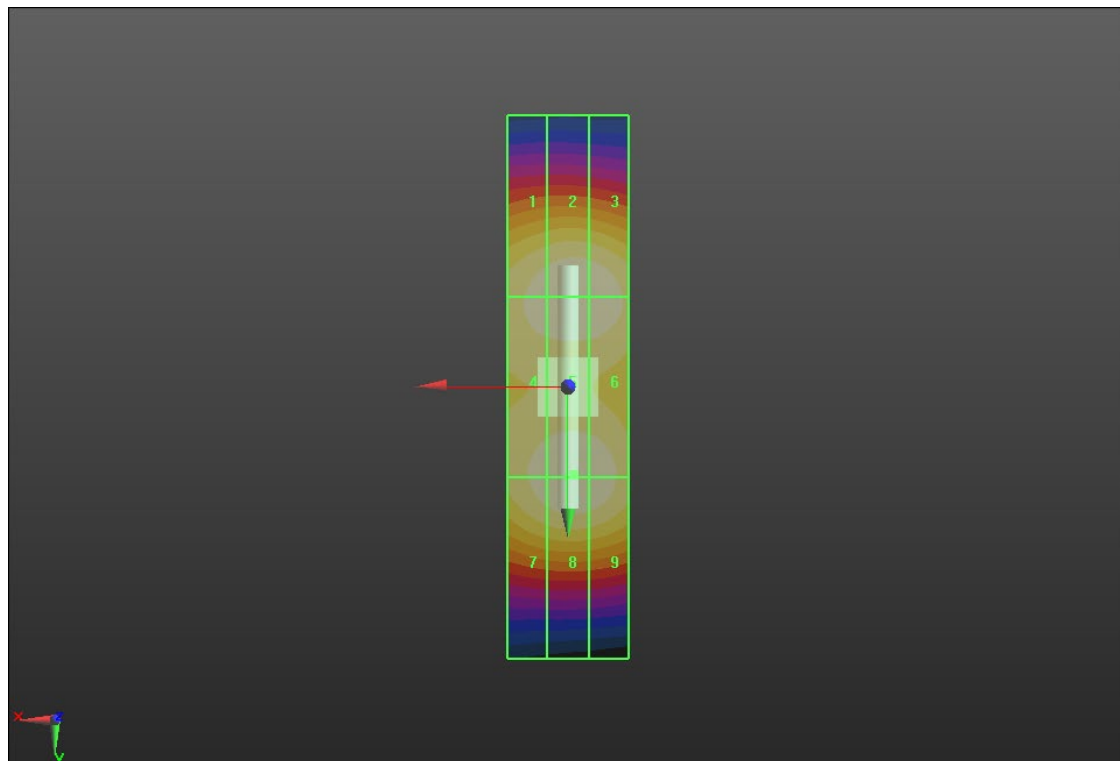
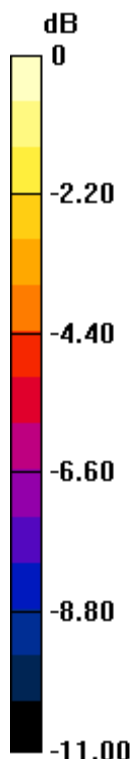

0 dB = 92.49 V/m = 39.32 dBV/m

HAC-RF Emission System Check

Communication System: UID 0, CW (0); Frequency: 5500 MHz; Duty Cycle: 1:1

Phantom section: RF Section

DASY5 Configuration:

- Probe: EF3DV3 - SN4041; ConvF(1, 1, 1) @ 5500 MHz; Calibrated: 3/18/2020
- Sensor-Surface: (Fix Surface)
- Electronics: DAE4 Sn1357; Calibrated: 2/20/2020
- Phantom: HAC Test Arch with AMCC; Type: SD HAC P01 BB
- Measurement SW: DASY52, Version 52.10 (4);SEMCAD X Version 14.6.14 (7483)

Dipole E-Field Measurement 5500MHz/5500 MHz/Hearing Aid Compatibility Test at 15mm distance (41x181x1): Interpolated grid: dx=0.5000 mm, dy=0.5000 mm

Device Reference Point: 0, 0, -6.3 mm

Reference Value = 26.08 V/m; Power Drift = 0.07 dB

Applied MIF = 0.00 dB

RF audio interference level = 40.59 dBV/m

Emission category: **M1**

MIF scaled E-field

Grid 1 M2 38.95 dBV/m	Grid 2 M2 39.18 dBV/m	Grid 3 M2 39 dBV/m
Grid 4 M1 40.42 dBV/m	Grid 5 M1 40.59 dBV/m	Grid 6 M1 40.41 dBV/m
Grid 7 M2 38.74 dBV/m	Grid 8 M2 38.95 dBV/m	Grid 9 M2 38.79 dBV/m

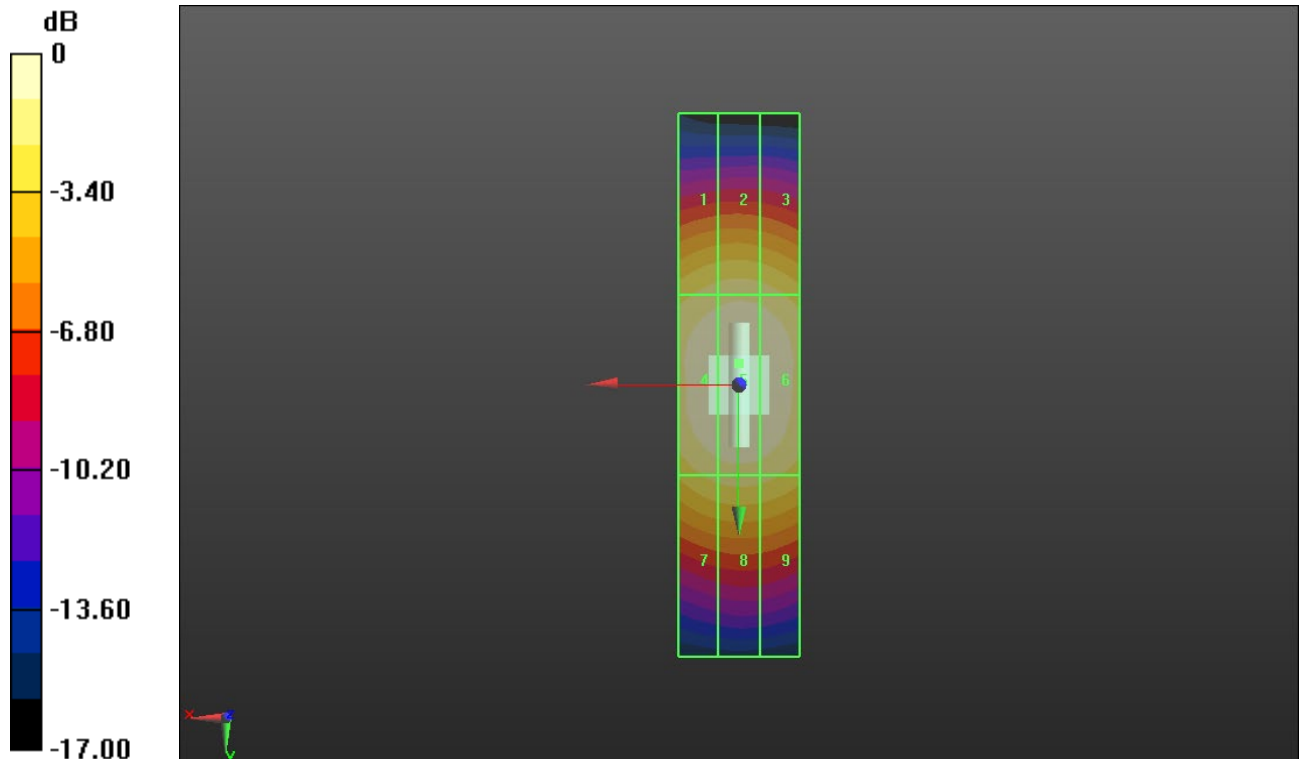

0 dB = 107.1 V/m = 40.60 dBV/m

HAC-RF Emission System Check

Communication System: UID 0, CW; Frequency: 835 MHz; Duty Cycle: 1:1
 Phantom section: RF Section
 DASY5 Configuration:
 - Probe: EF3DV3 - SN4041; ConvF(1, 1, 1) @ 835 MHz; Calibrated: 3/18/2020
 - Sensor-Surface: (Fix Surface)
 - Electronics: DAE4 Sn1357; Calibrated: 2/20/2020
 - Phantom: HAC Test Arch with AMCC; Type: SD HAC P01 BB
 - Measurement SW: DASY52, Version 52.10 (4);SEMCAD X Version 14.6.14 (7483)

Dipole E-Field measurement 835MHz/835 MHz/Hearing Aid Compatibility Test at 15mm distance (41x361x1):

Interpolated grid: dx=0.5000 mm, dy=0.5000 mm
 Device Reference Point: 0, 0, -6.3 mm
 Reference Value = 142.1 V/m; Power Drift = -0.24 dB
 Applied MIF = 0.00 dB
 RF audio interference level = 41.97 dBV/m

Emission category: **M3**

MIF scaled E-field

Grid 1 M3 40.48 dBV/m	Grid 2 M3 40.92 dBV/m	Grid 3 M3 40.84 dBV/m
Grid 4 M4 36.35 dBV/m	Grid 5 M4 36.49 dBV/m	Grid 6 M4 36.42 dBV/m
Grid 7 M3 41.66 dBV/m	Grid 8 M3 41.97 dBV/m	Grid 9 M3 41.8 dBV/m

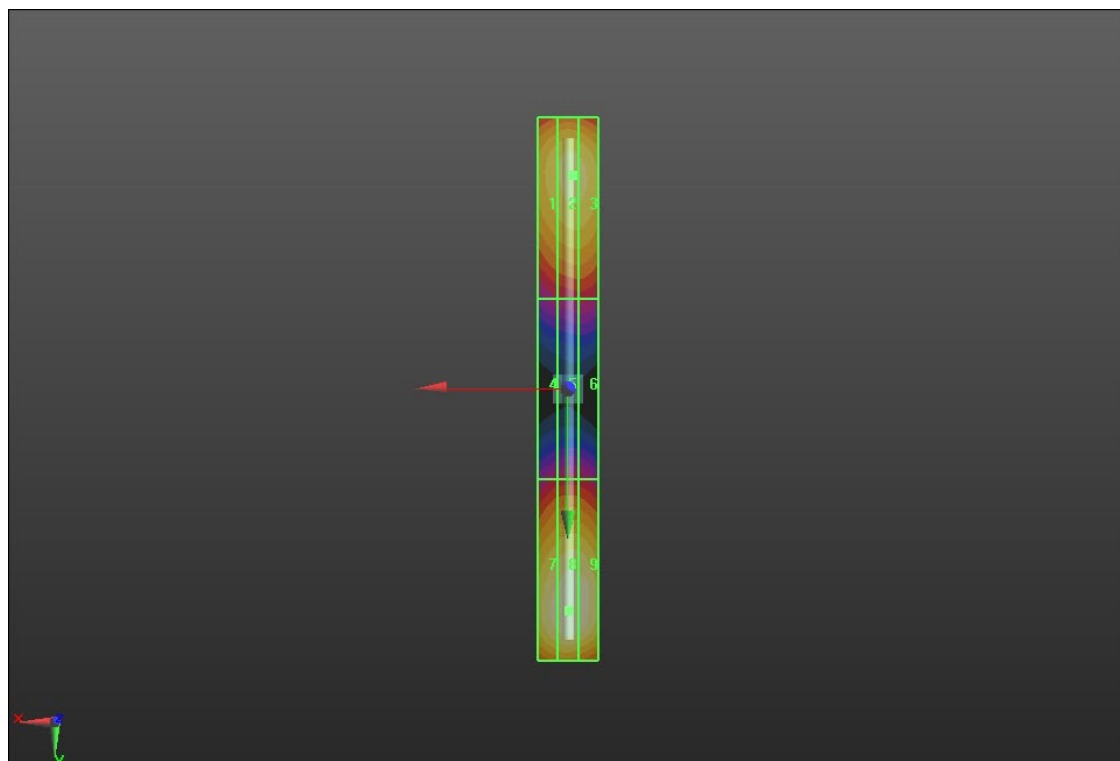
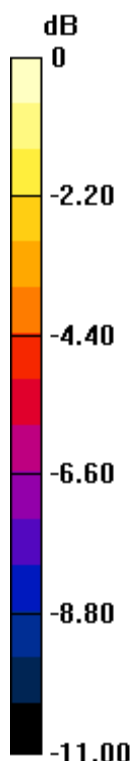

0 dB = 125.5 V/m = 41.97 dBV/m

HAC-RF Emission System Check

Communication System: UID 0, CW; Frequency: 1880 MHz; Duty Cycle: 1:1
 Phantom section: RF Section
 DASY5 Configuration:
 - Probe: EF3DV3 - SN4041; ConvF(1, 1, 1) @ 1880 MHz; Calibrated: 3/18/2020
 - Sensor-Surface: (Fix Surface)
 - Electronics: DAE4 Sn1357; Calibrated: 2/20/2020
 - Phantom: HAC Test Arch with AMCC; Type: SD HAC P01 BB
 - Measurement SW: DASY52, Version 52.10 (4);SEMCAD X Version 14.6.14 (7483)

Dipole E-Field Measurement 1880MHz/1880 MHz/Hearing Aid Compatibility Test at 15mm distance (41x181x1):

Interpolated grid: dx=0.5000 mm, dy=0.5000 mm
 Device Reference Point: 0, 0, -6.3 mm
 Reference Value = 166.4 V/m; Power Drift = 0.07 dB
 Applied MIF = 0.00 dB
 RF audio interference level = 40.08 dBV/m

Emission category: **M1**

MIF scaled E-field

Grid 1 M2 39.05 dBV/m	Grid 2 M2 39.34 dBV/m	Grid 3 M2 39.28 dBV/m
Grid 4 M2 36.4 dBV/m	Grid 5 M2 36.68 dBV/m	Grid 6 M2 36.66 dBV/m
Grid 7 M2 39.57 dBV/m	Grid 8 M1 40.08 dBV/m	Grid 9 M1 40.03 dBV/m

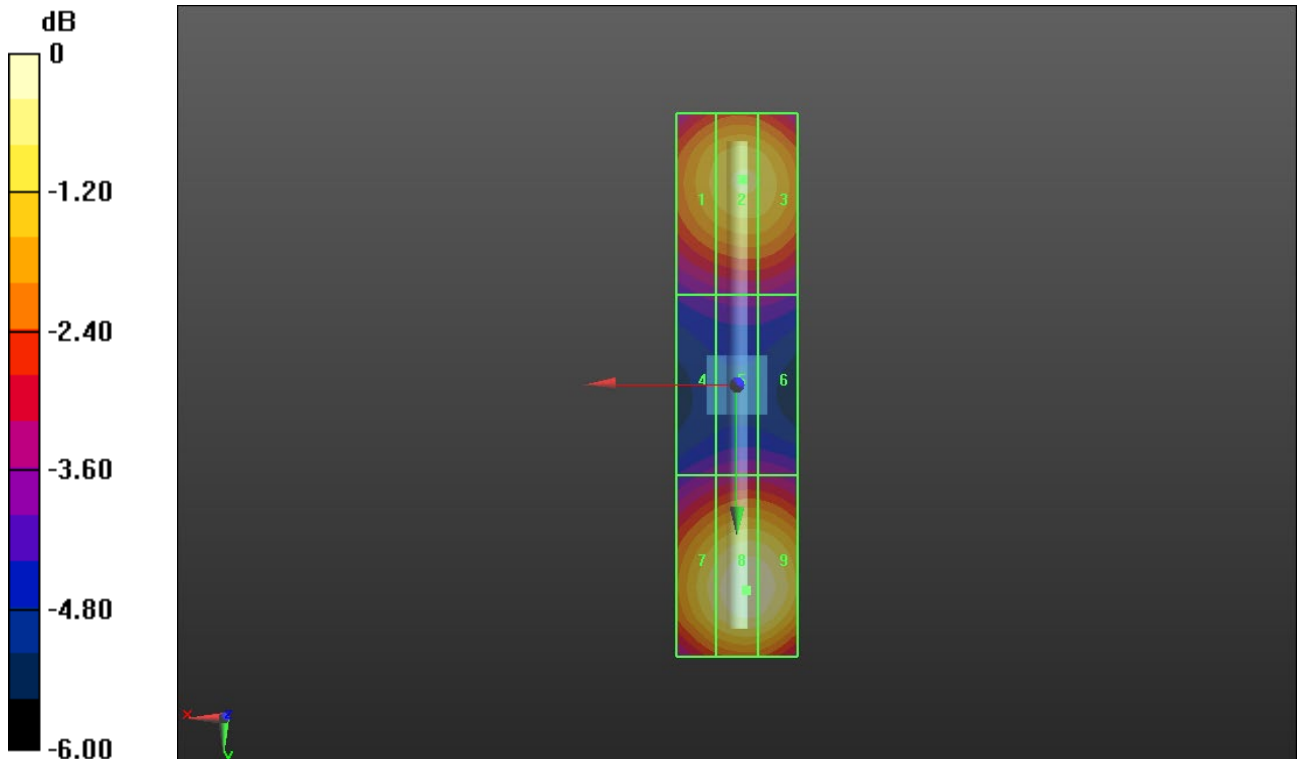

0 dB = 100.9 V/m = 40.08 dBV/m

HAC-RF Emission System Check

Communication System: UID 0, CW (0); Frequency: 2450 MHz; Duty Cycle: 1:1

Phantom section: RF Section

DASY5 Configuration:

- Probe: EF3DV3 - SN4041; ConvF(1, 1, 1) @ 2450 MHz; Calibrated: 3/18/2020
- Sensor-Surface: (Fix Surface)
- Electronics: DAE4 Sn1357; Calibrated: 2/20/2020
- Phantom: HAC Test Arch with AMCC; Type: SD HAC P01 BB
- Measurement SW: DASY52, Version 52.10 (4);SEMCAD X Version 14.6.14 (7483)

Dipole E-Field Measurement 2450MHz/2450 MHz/Hearing Aid Compatibility Test at 15mm distance (41x181x1): Interpolated grid: dx=0.5000 mm, dy=0.5000 mm

Device Reference Point: 0, 0, -6.3 mm

Reference Value = 78.93 V/m; Power Drift = -0.06 dB

Applied MIF = 0.00 dB

RF audio interference level = 39.48 dBV/m

Emission category: **M2**

MIF scaled E-field

Grid 1 M2 39.09 dBV/m	Grid 2 M2 39.48 dBV/m	Grid 3 M2 39.39 dBV/m
Grid 4 M2 38.02 dBV/m	Grid 5 M2 38.3 dBV/m	Grid 6 M2 38.27 dBV/m
Grid 7 M2 39 dBV/m	Grid 8 M2 39.36 dBV/m	Grid 9 M2 39.25 dBV/m

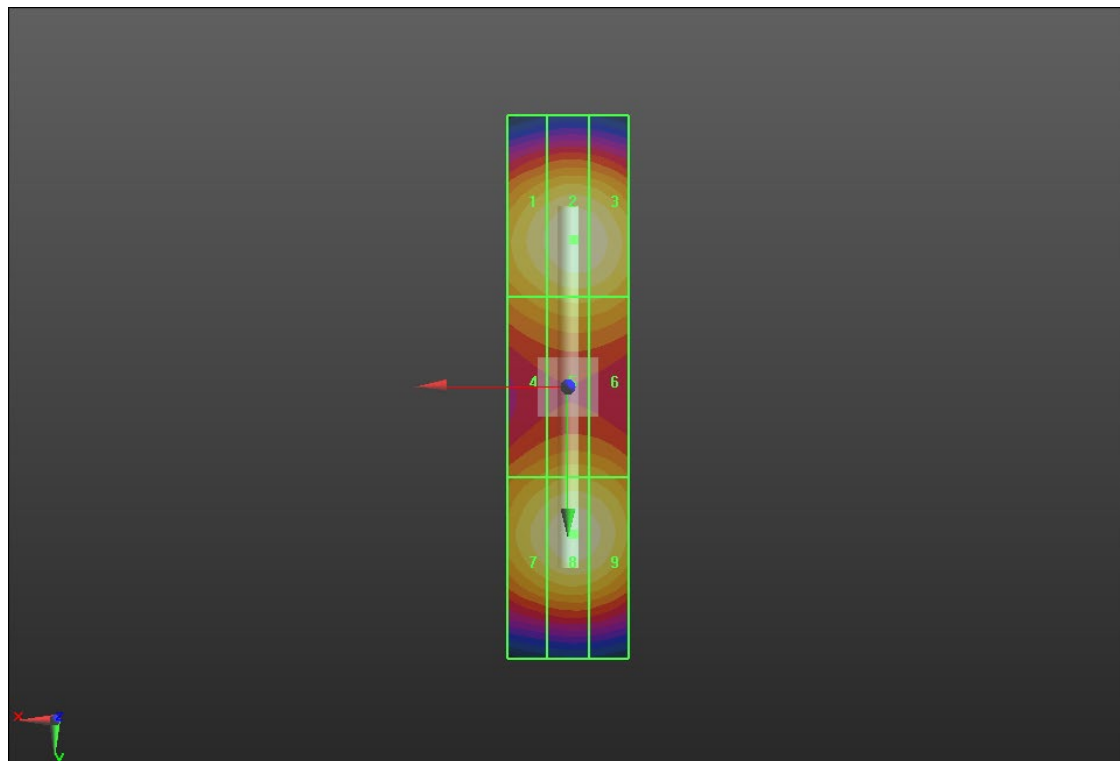
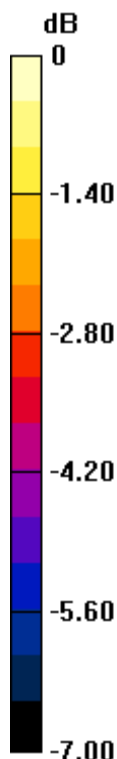

0 dB = 94.18 V/m = 39.48 dBV/m

HAC-RF Emission System Check

Communication System: UID 0, CW (0); Frequency: 2600 MHz; Duty Cycle: 1:1

Phantom section: RF Section

DASY5 Configuration:

- Probe: EF3DV3 - SN4041; ConvF(1, 1, 1) @ 2600 MHz; Calibrated: 3/18/2020
- Sensor-Surface: (Fix Surface)
- Electronics: DAE4 Sn1357; Calibrated: 2/20/2020
- Phantom: HAC Test Arch with AMCC; Type: SD HAC P01 BB
- Measurement SW: DASY52, Version 52.10 (4);SEMCAD X Version 14.6.14 (7483)

Dipole E-Field Measurement 2600MHz/2600 MHz/Hearing Aid Compatibility Test at 15mm distance (41x181x1): Interpolated grid: dx=0.5000 mm, dy=0.5000 mm

Device Reference Point: 0, 0, -6.3 mm

Reference Value = 69.63 V/m; Power Drift = 0.03 dB

Applied MIF = 0.00 dB

RF audio interference level = 39.42 dBV/m

Emission category: **M2**

MIF scaled E-field

Grid 1 M2 38.74 dBV/m	Grid 2 M2 39.1 dBV/m	Grid 3 M2 39.03 dBV/m
Grid 4 M2 38.19 dBV/m	Grid 5 M2 38.52 dBV/m	Grid 6 M2 38.47 dBV/m
Grid 7 M2 38.99 dBV/m	Grid 8 M2 39.42 dBV/m	Grid 9 M2 39.34 dBV/m

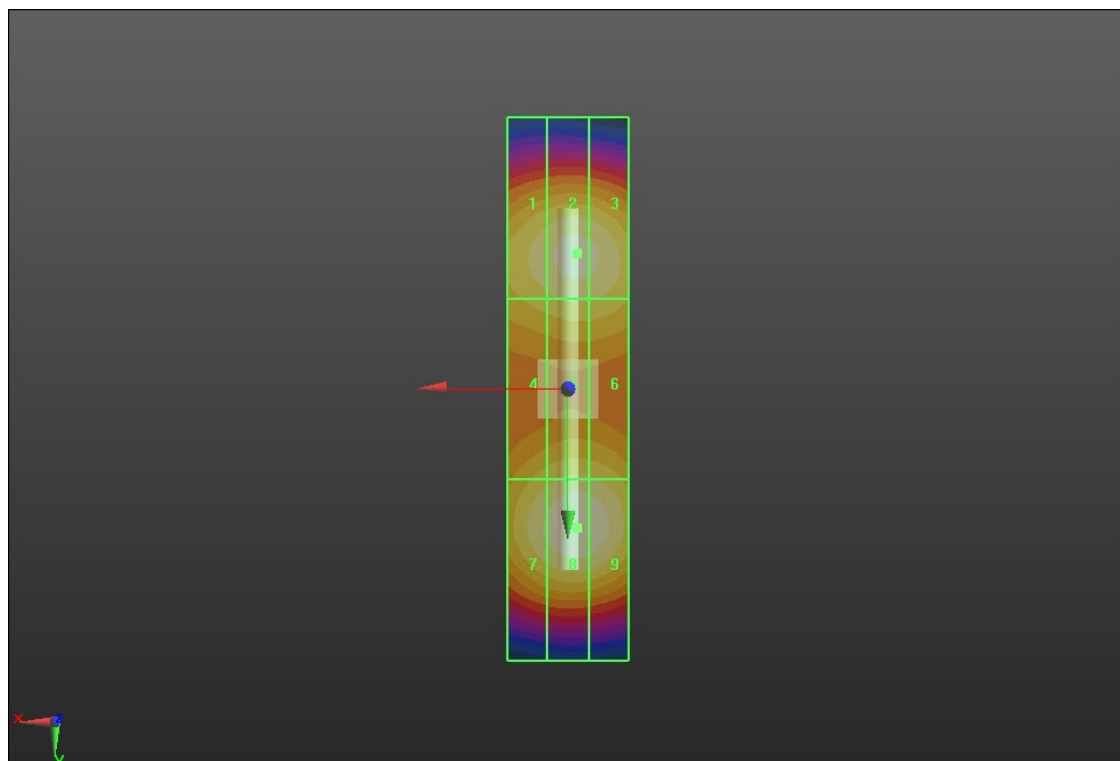
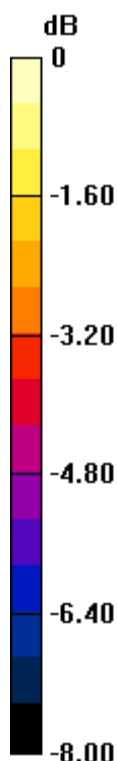

0 dB = 93.58 V/m = 39.42 dBV/m

HAC-RF Emission System Check

Communication System: UID 0, CW (0); Frequency: 3500 MHz; Duty Cycle: 1:1

Phantom section: RF Section

DASY5 Configuration:

- Probe: EF3DV3 - SN4041; ConvF(1, 1, 1) @ 3500 MHz; Calibrated: 3/18/2020
- Sensor-Surface: (Fix Surface)
- Electronics: DAE4 Sn1357; Calibrated: 2/20/2020
- Phantom: HAC Test Arch with AMCC; Type: SD HAC P01 BB
- Measurement SW: DASY52, Version 52.10 (4);SEMCAD X Version 14.6.14 (7483)

Dipole E-Field Measurement 3500MHz/3500 MHz/Hearing Aid Compatibility Test at 15mm distance (41x181x1):

Interpolated grid: dx=0.5000 mm, dy=0.5000 mm

Device Reference Point: 0, 0, -6.3 mm

Reference Value = 35.59 V/m; Power Drift = 0.07 dB

Applied MIF = 0.00 dB

RF audio interference level = 39.50 dBV/m

Emission category: **M2**

MIF scaled E-field

Grid 1 M2 38.8 dBV/m	Grid 2 M2 39.16 dBV/m	Grid 3 M2 39.13 dBV/m
Grid 4 M2 39.14 dBV/m	Grid 5 M2 39.5 dBV/m	Grid 6 M2 39.41 dBV/m
Grid 7 M2 39.13 dBV/m	Grid 8 M2 39.49 dBV/m	Grid 9 M2 39.41 dBV/m

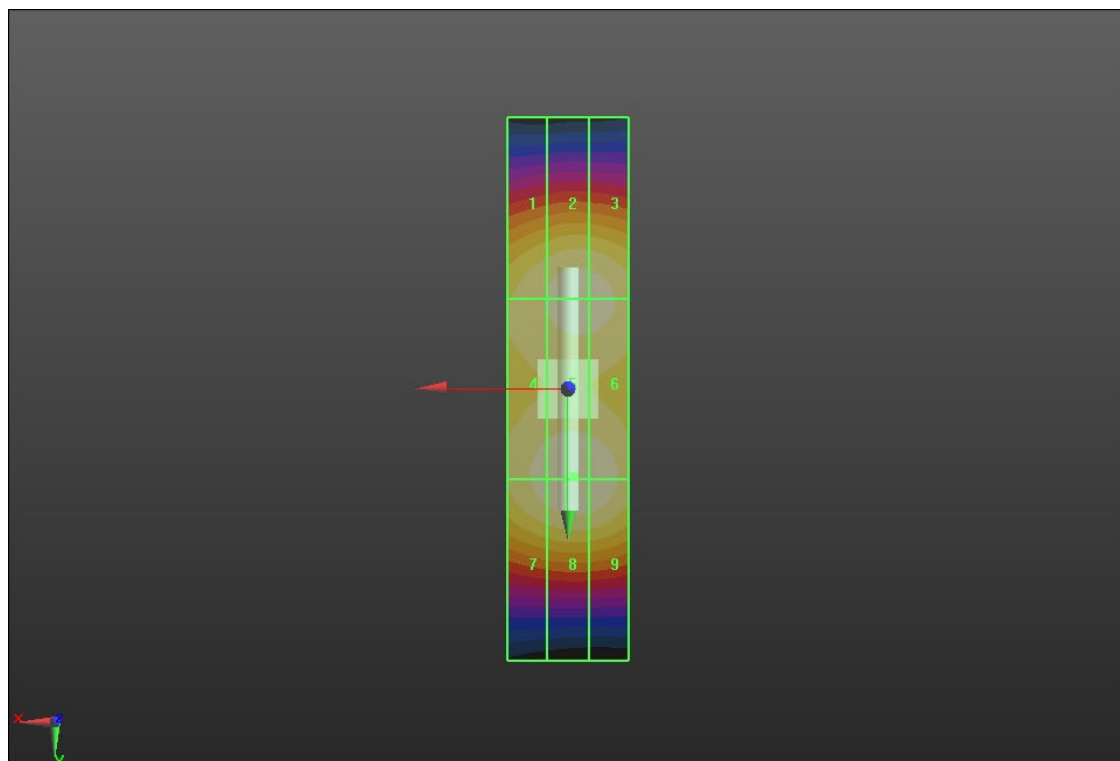
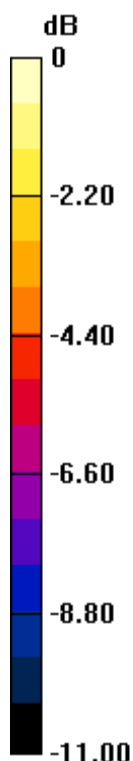

0 dB = 94.36 V/m = 39.50 dBV/m

HAC-RF Emission System Check

Communication System: UID 0, CW (0); Frequency: 5500 MHz; Duty Cycle: 1:1

Phantom section: RF Section

DASY5 Configuration:

- Probe: EF3DV3 - SN4041; ConvF(1, 1, 1) @ 5500 MHz; Calibrated: 3/18/2020
- Sensor-Surface: (Fix Surface)
- Electronics: DAE4 Sn1357; Calibrated: 2/20/2020
- Phantom: HAC Test Arch with AMCC; Type: SD HAC P01 BB
- Measurement SW: DASY52, Version 52.10 (4);SEMCAD X Version 14.6.14 (7483)

Dipole E-Field Measurement 5500MHz/5500 MHz/Hearing Aid Compatibility Test at 15mm distance (41x181x1): Interpolated grid: dx=0.5000 mm, dy=0.5000 mm

Device Reference Point: 0, 0, -6.3 mm

Reference Value = 25.84 V/m; Power Drift = -0.31 dB

Applied MIF = 0.00 dB

RF audio interference level = 40.63 dBV/m

Emission category: **M1**

MIF scaled E-field

Grid 1 M2 38.91 dBV/m	Grid 2 M2 39.2 dBV/m	Grid 3 M2 39.01 dBV/m
Grid 4 M1 40.47 dBV/m	Grid 5 M1 40.63 dBV/m	Grid 6 M1 40.38 dBV/m
Grid 7 M2 38.71 dBV/m	Grid 8 M2 38.95 dBV/m	Grid 9 M2 38.8 dBV/m

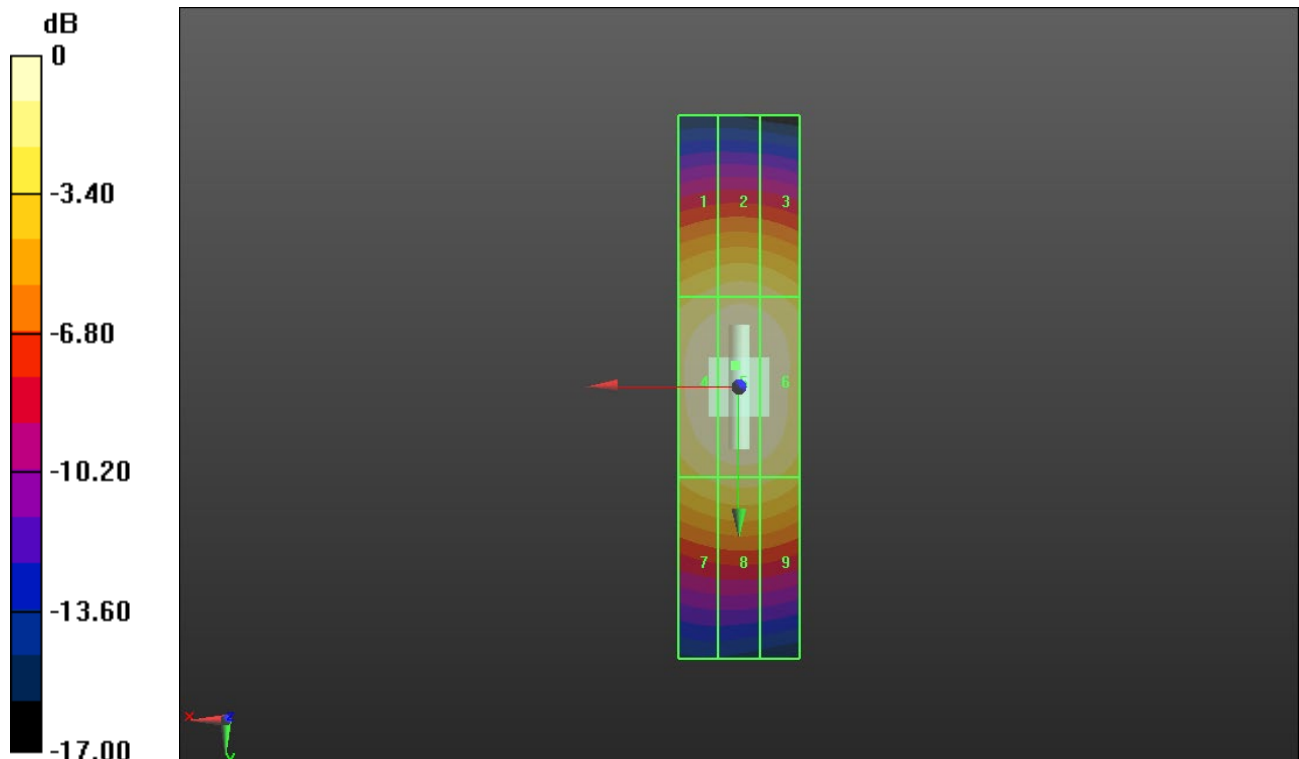

0 dB = 107.6 V/m = 40.64 dBV/m