



TEST REPORT

Report Number: 13190901-E3V1

Applicant : APPLE, INC.
1 APPLE PARK WAY
CUPERTINO, CA 95014, U.S.A

Model : A2398

FCC ID : BCG-E3540A

IC : 579C-E3540A

EUT Description : SMARTPHONE

Test Standard(s) : FCC 47 CFR PART 15 SUBPART C
ISED RSS-247 ISSUE 2
ISED RSS-GEN ISSUE 5

Date of Issue:

September 21, 2020

Prepared by:

UL Verification Services Inc.
47173 Benicia Street
Fremont, CA 94538 U.S.A.
TEL: (510) 319-4000
FAX: (510) 661-0888

REPORT REVISION HISTORY

Rev.	Issue Date	Revisions	Revised By
V1	9/21/2020	Initial Issue	Chin Pang

TABLE OF CONTENTS

REPORT REVISION HISTORY	2
TABLE OF CONTENTS	3
1. ATTESTATION OF TEST RESULTS	4
2. TEST SUMMARY	5
3. TEST METHODOLOGY	5
4. FACILITIES AND ACCREDITATION	5
5. DECISION RULES AND MEASUREMENT UNCERTAINTY	6
5.1. METROLOGICAL TRACEABILITY	6
5.2. DECISION RULES.....	6
5.3. MEASUREMENT UNCERTAINTY.....	6
6. EQUIPMENT UNDER TEST	7
6.1. EUT DESCRIPTION	7
6.2. INTRODUCTION	7
6.3. SPOT CHECK VERIFICATION RESULTS SUMMARY	7
6.4. REFERENCE DETAIL	14
6.5. DESCRIPTION OF AVAILABLE ANTENNAS	14
6.6. SOFTWARE AND FIRMWARE.....	14
6.7. WORST-CASE CONFIGURATION AND MODE.....	14
6.8. DESCRIPTION OF TEST SETUP.....	15
7. MEASUREMENT METHOD.....	16
8. TEST AND MEASUREMENT EQUIPMENT	17
9. SETUP PHOTOS.....	18
Appendix A – Reference Test Report	19

1. ATTESTATION OF TEST RESULTS

COMPANY NAME: APPLE INC.
1 APPLE PARK WAY
CUPERTINO, CA 95014, U.S.A

EUT DESCRIPTION: SMARTPHONE

MODEL: A2398

SERIAL NUMBER: Original: C7CD603Z08HK, C7CCT014Q90Y
Spot check: C7CCV009Q8YX, C7CCT008Q908

DATE TESTED: AUGUST 25 – 27, 2020

APPLICABLE STANDARDS	
STANDARD	TEST RESULTS
CFR 47 Part 15 Subpart C	Complies
ISED RSS-247 Issue 2	Complies
ISED RSS-GEN Issue 5	Complies

UL Verification Services Inc. tested the above equipment in accordance with the requirements set forth in the above standards. The test results show that the equipment tested is capable of demonstrating compliance with the requirements as documented in this report.

The results documented in this report apply only to the tested sample, under the conditions and modes of operation as described herein. It is the manufacturer's responsibility to assure that additional production units of this model are manufactured with identical electrical and mechanical components. All samples tested were in good operating condition throughout the entire test program. Measurement Uncertainties are published for informational purposes only and were not taken into account unless noted otherwise.

This document may not be altered or revised in any way unless done so by UL Verification Services Inc. and all revisions are duly noted in the revisions section. Any alteration of this document not carried out by UL Verification Services Inc. will constitute fraud and shall nullify the document. This report must not be used by the client to claim product certification, approval, or endorsement by NVLAP, NIST, any agency of the Federal Government, or any agency of the U.S. government.

Approved & Released For
UL Verification Services Inc. By:



Chin Pang
Senior Engineer
Consumer Technology Division
UL Verification Services Inc.

Prepared By:



Tony Li
Test Engineer
Consumer Technology Division
UL Verification Services Inc.

2. TEST SUMMARY

FCC Clause	ISED Clause	Requirement	Result	Comment
15.209, 15.205	RSS-GEN 8.9, 8.10	Radiated Emissions	Complies	None.

3. TEST METHODOLOGY

The tests documented in this report were performed in accordance with FCC CFR 47 Part 2, FCC CFR 47 Part 15, ANSI C63.10-2013, KDB 558074 D01 15.247 Meas Guidance v05r02, KDB662911, RSS-GEN Issue 5, and RSS-247 Issue 2.

4. FACILITIES AND ACCREDITATION

The test sites and measurement facilities used to collect data are located at 47173 and 47266 Benicia Street, and 47658 Kato Road, Fremont, California, USA. Line conducted emissions are measured only at the 47173 address. The following table identifies which facilities were utilized for radiated emission measurements documented in this report. Specific facilities are also identified in the test results sections.

47173 Benicia Street	47266 Benicia Street	47658 Kato Rd.
<input type="checkbox"/> Chamber A (IC:2324B-1)	<input type="checkbox"/> Chamber D (IC:22541-1)	<input checked="" type="checkbox"/> Chamber I (IC: 2324A-5)
<input type="checkbox"/> Chamber B (IC:2324B-2)	<input type="checkbox"/> Chamber E (IC:22541-2)	<input checked="" type="checkbox"/> Chamber J (IC: 2324A-6)
<input type="checkbox"/> Chamber C (IC:2324B-3)	<input type="checkbox"/> Chamber F (IC:22541-3)	<input type="checkbox"/> Chamber K (IC: 2324A-1)
	<input type="checkbox"/> Chamber G (IC:22541-4)	<input type="checkbox"/> Chamber L (IC: 2324A-3)
	<input type="checkbox"/> Chamber H (IC:22541-5)	<input type="checkbox"/> Chamber M (IC: 2324A-2)

The above test sites and facilities are covered under FCC Test Firm Registration # 208313. Chambers above are covered under Industry Canada company address and respective code.

UL Verification Services Inc. is accredited by NVLAP, Laboratory Code 200065-0.

5. DECISION RULES AND MEASUREMENT UNCERTAINTY

5.1. METROLOGICAL TRACEABILITY

All test and measuring equipment utilized to perform the tests documented in this report are calibrated on a regular basis, with a maximum time between calibrations of one year or the manufacturers' recommendation, whichever is less, and where applicable is traceable to recognized national standards.

5.2. DECISION RULES

The Decision Rule is based on Simple Acceptance in accordance with ISO Guide 98-4:2012 Clause 8.2. (Measurement uncertainty is not taken into account when stating conformity with a specified requirement.)

5.3. MEASUREMENT UNCERTAINTY

Where relevant, the following measurement uncertainty levels have been estimated for tests performed on the apparatus:

PARAMETER	U _{LAB}
Worst Case Conducted Disturbance, 9KHz to 0.15 MHz	3.39 dB
Worst Case Conducted Disturbance, 0.15 to 30 MHz	3.07 dB
Worst Case Radiated Disturbance, 9KHz to 30 MHz	2.52 dB
Worst Case Radiated Disturbance, 30 to 1000 MHz	4.88 dB
Worst Case Radiated Disturbance, 1000 to 18000 MHz	4.24 dB
Worst Case Radiated Disturbance, 18000 to 26000 MHz	4.37 dB
Worst Case Radiated Disturbance, 26000 to 40000 MHz	5.17 dB

Uncertainty figures are valid to a confidence level of 95%.

6. EQUIPMENT UNDER TEST

6.1. EUT DESCRIPTION

The Apple iPhone is a smartphone with multimedia functions (music, application support, and video), cellular GSM, GPRS, EGPRS, UMTS, LTE, 5G, CDMA, IEEE 802.11a/b/g/n/ac/ax, Bluetooth, Ultra-Wideband, GPS, NFC and WPT. All models support at least one UICC based SIM. The second SIM is either an UICC based p-SIM (physical SIM) or e-SIM (electronic SIM). The device supports a built-in inductive charging transmitter and receiver. The rechargeable battery is not user accessible.

6.2. INTRODUCTION

This application for certification is leveraging the data reuse procedures from KDB 484596 D01 based on reference FCC ID: BCG-E3539A, IC ID: 579C-E3539A to cover variant model BCG-E3540A, 579C-E3540A. The major difference between the parent/reference model and the variant model is the depopulation in the variant model of the mmWave transmitter. All other circuitry and features are identical. The data reuse test plan was approved via manufacturer KDB inquiry.

6.3. SPOT CHECK VERIFICATION RESULTS SUMMARY

Spot check verification has been done on device model A2398, FCC ID: BCG-E3540A, IC: 579C-E3540A for radiated spurious and radiated band-edge in accordance with the Test Plan that was approved via KDB inquiry.

BCG-E3540A / 579C-E3540A SPOT CHECK RESULTS										
Technology	Mode	Test Item	Channel	Measured Frequency	Original model		Spot check model		Delta (dB)	
					A2176		A2398			
					BCG-E3539A 579C-E3539A		BCG-E3540A 579C-E3540A			
					Peak	Ave	Peak	Ave	Peak	Ave
HDR	HDR8 TXBF ePA	RBE	Low	2.38896	62.41	51.05	55.96	42.29	-6.45	-8.76
			High	2.48351	63.56	49.45	56.73	43.74	-6.83	-5.71
		RSE	Mid	11.93409/11.12412	51.29	40.79	52.99	41.88	1.7	1.09

Comparison of the models, upper deviation is within 3dB range and all tests are under FCC Technical Limits. The test report for FCC ID: BCG-E3539A, IC: 579C-E3539A is therefore being used to support the application for certification for FCC ID: BCG-E3540A, IC: 579C-E3540A.

Note: The output powers were verified on model A2398 to match with model A2176 before radiated emissions spot check was performed.

SPOT CHECK DATA

BANDEDGE (LOW CHANNEL)

HORIZONTAL RESULT

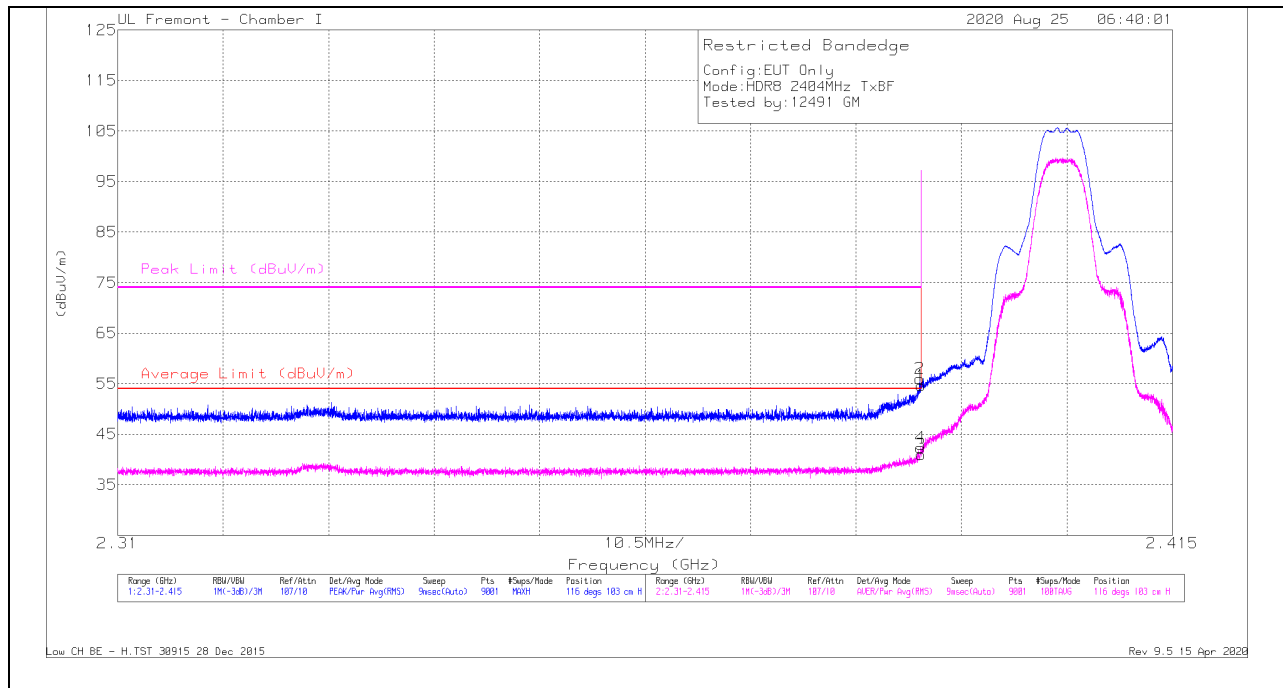

Trace Markers

Marker	Frequency (GHz)	Meter Reading (dBuV)	Det	AF T346 (dB/m)	Amp/Cbl/Filtr/Pa d (dB)	Corrected Reading (dBuV/m)	Average Limit (dBuV/m)	Margin (dB)	Peak Limit (dBuV/m)	PK Margin (dB)	Azimuth (Degs)	Height (cm)	Polarity
1	* 2.38999	39.92	Pk	32	-17.3	54.62	-	-	74	-19.38	116	103	H
2	* 2.38988	41.26	Pk	32	-17.3	55.96	-	-	74	-18.04	116	103	H
3	* 2.38999	26.27	RMS	32	-17.3	40.97	54	-13.03	-	-	116	103	H
4	* 2.38992	27.59	RMS	32	-17.3	42.29	54	-11.71	-	-	116	103	H

* - indicates frequency in CFR47 Pt 15 / IC RSS-Restricted Band

Pk - Peak detector

RMS - RMS detection

VERTICAL RESULT

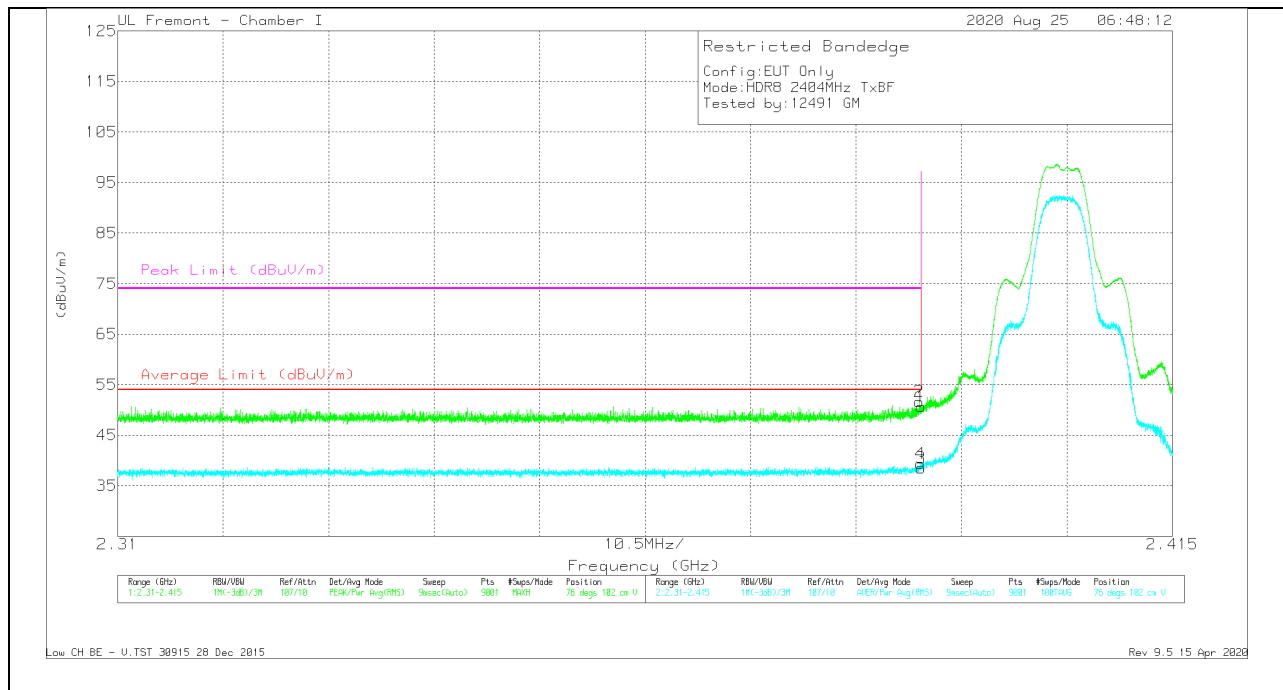

Trace Markers

Marker	Frequency (GHz)	Meter Reading (dBuV)	Det	AF T346 (dB/m)	Amp/Cb/Fitr/Pa d (dB)	Corrected Reading (dBuV/m)	Average Limit (dBuV/m)	Margin (dB)	Peak Limit (dBuV/m)	PK Margin (dB)	Azimuth (Degs)	Height (cm)	Polarity
1	* 2.38999	35.99	Pk	32	-17.3	50.69	-	-	74	-23.31	76	102	V
2	* 2.38978	36.98	Pk	32	-17.3	51.68	-	-	74	-22.32	76	102	V
3	* 2.38999	23.84	RMS	32	-17.3	38.54	54	-15.46	-	-	76	102	V
4	* 2.38992	24.69	RMS	32	-17.3	39.39	54	-14.61	-	-	76	102	V

* - indicates frequency in CFR47 Pt 15 / IC RSS-Restricted Band
 Pk - Peak detector
 RMS - RMS detection

BANDEDGE (HIGH CHANNEL)

HORIZONTAL RESULT

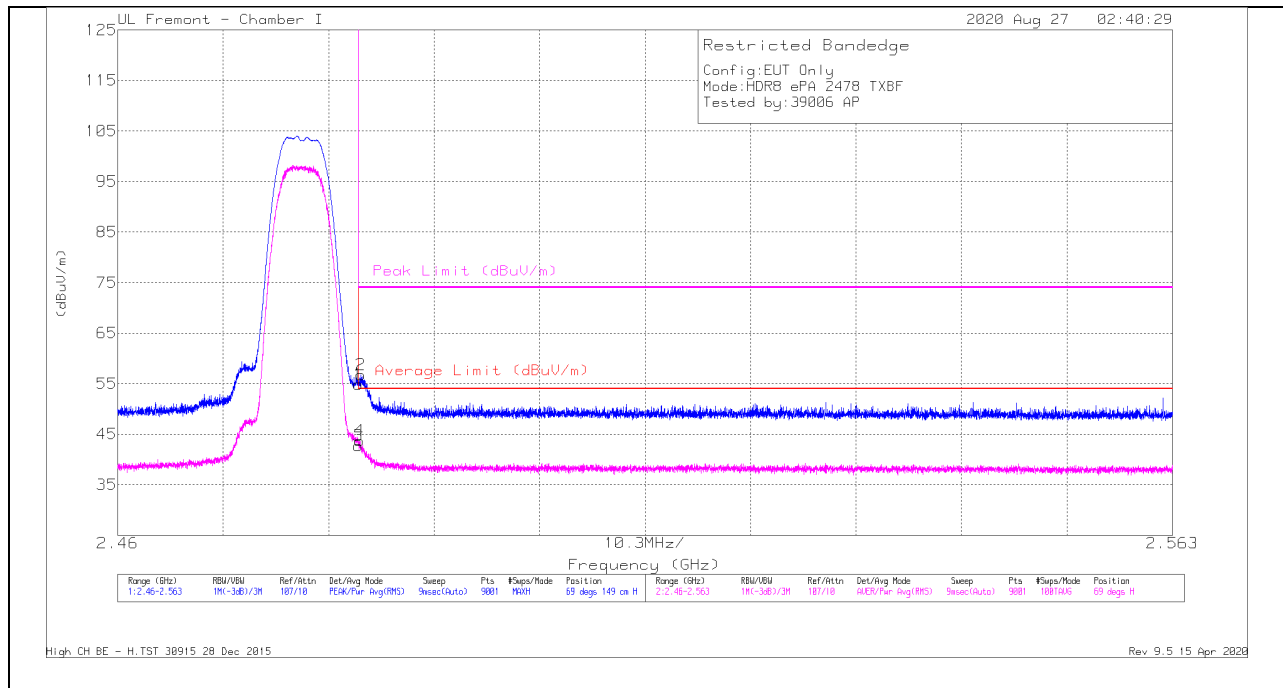

Trace Markers

Marker	Frequency (GHz)	Meter Reading (dBuV)	Det	AF T346 (dB/m)	Amp/Cb/Filt/Pa d (dB)	Corrected Reading (dBuV/m)	Average Limit (dBuV/m)	Margin (dB)	Peak Limit (dBuV/m)	PK Margin (dB)	Azimuth (Degs)	Height (cm)	Polarity
1	* 2.48351	40.17	Pk	32.4	-17.7	54.87	-	-	74	-19.13	69	149	H
2	* 2.48377	42.03	Pk	32.4	-17.7	56.73	-	-	74	-17.27	69	149	H
3	* 2.48351	27.98	RMS	32.4	-17.7	42.68	54	-11.32	-	-	69	149	H
4	* 2.48361	29.04	RMS	32.4	-17.7	43.74	54	-10.26	-	-	69	149	H

* - indicates frequency in CFR47 Pt 15 / IC RSS-Restricted Band

Pk - Peak detector

RMS - RMS detection

VERTICAL RESULT

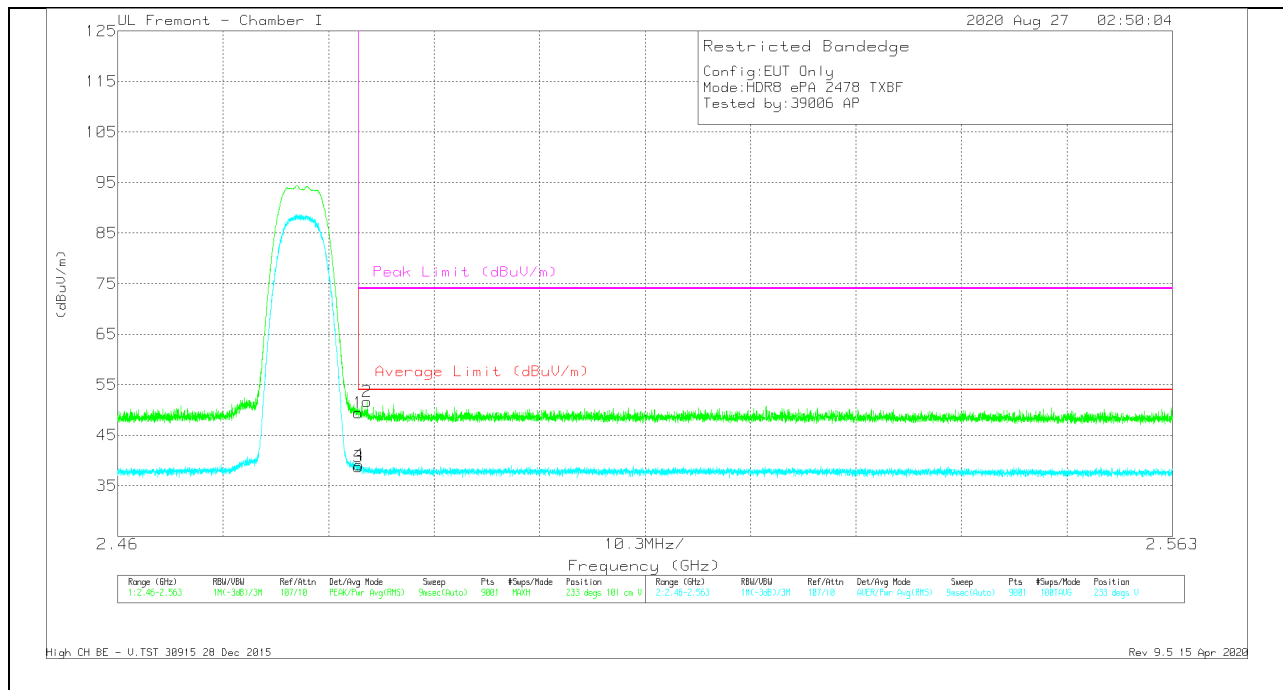

Trace Markers

Marker	Frequency (GHz)	Meter Reading (dBuV)	Det	AF T346 (dB/m)	Amp/Cb/Fitr/Pa d (dB)	Corrected Reading (dBuV/m)	Average Limit (dBuV/m)	Margin (dB)	Peak Limit (dBuV/m)	PK Margin (dB)	Azimuth (Degs)	Height (cm)	Polarity
1	* 2.48351	34.73	Pk	32.4	-17.7	49.43	-	-	74	-24.57	233	101	V
2	* 2.48438	36.96	Pk	32.4	-17.7	51.66	-	-	74	-22.34	233	101	V
3	* 2.48351	24.03	RMS	32.4	-17.7	38.73	54	-15.27	-	-	233	101	V
4	* 2.48353	24.41	RMS	32.4	-17.7	39.11	54	-14.89	-	-	233	101	V

* - indicates frequency in CFR47 Pt 15 / IC RSS-Restricted Band
 Pk - Peak detector
 RMS - RMS detection

HARMONICS AND SPURIOUS EMISSIONS

MID CHANNEL RESULTS

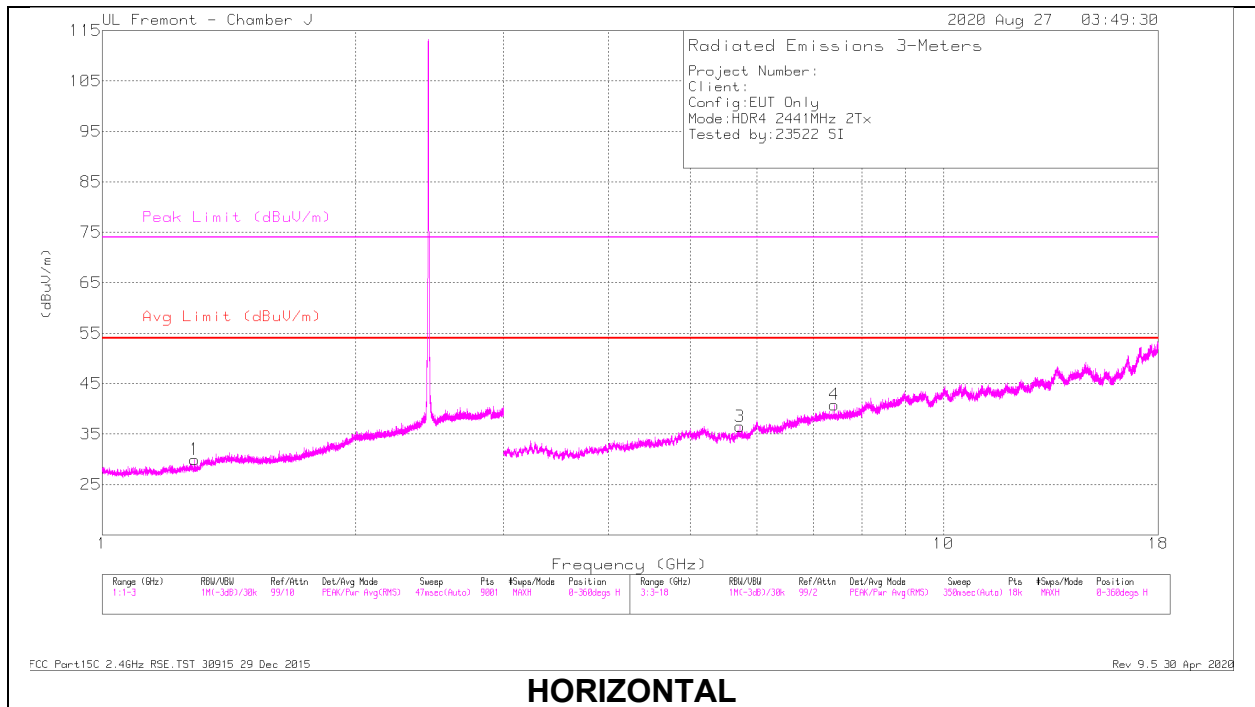

HORIZONTAL

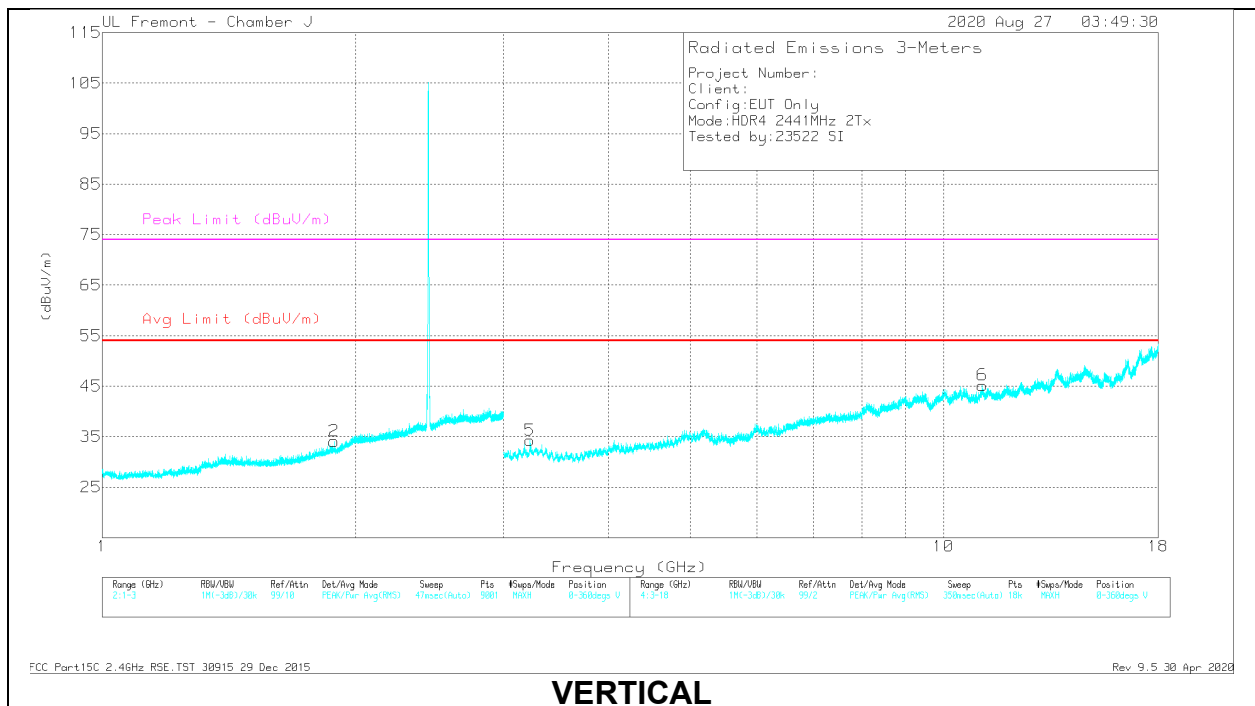

VERTICAL

Radiated Emissions

Marker	Frequency (GHz)	Meter Reading (dBuV)	Det	AF T963 (dB/m)	Amp/Cbl/Filtr/Pad (dB)	Corrected Reading (dBuV/m)	Avg Limit (dBuV/m)	Margin (dB)	Peak Limit (dBuV/m)	PK Margin (dB)	Azimuth (Degs)	Height (cm)	Polarity
1	* 1.28648	29.5	PK2	24.9	-17.4	37	-	-	74	-37	5	354	H
	* 1.28851	19.6	MAv1	25	-17.4	27.2	54	-26.8	-	-	5	354	H
2	1.88618	29.97	PK2	26.5	-15.6	40.87	-	-	-	-	44	266	V
	5.72791	38.95	PK2	33.4	-28.4	43.95	-	-	-	-	224	289	H
4	* 7.41469	36.58	PK2	37.1	-26.6	47.08	-	-	74	-26.92	15	130	H
	* 7.41454	26.56	MAv1	37.1	-26.6	37.06	54	-16.94	-	-	15	130	H
5	3.22644	42.95	PK2	31.6	-33.5	41.05	-	-	-	-	188	356	V
	* 11.12412	35.39	PK2	39.6	-22	52.99	-	-	74	-21.01	237	153	V
6	* 11.12012	24.08	MAv1	39.7	-21.9	41.88	54	-12.12	-	-	237	153	V

* - indicates frequency in CFR47 Pt 15 / IC RSS-Restricted Band
 PK2 - KDB558074 Method: Maximum Peak
 MAv1 - KDB558074 Option 1 Maximum RMS Average

6.4. REFERENCE DETAIL

Reference application that contains the reused reference data which is attached to this report in Appendix A.

Equipment Class	Reference FCC ID / IC	Reference Report Number	Report Title/Section
DTS	BCG-E3539A 579C-E3539A	13179110-E3	FCC_IC Report HDR / All sections

6.5. DESCRIPTION OF AVAILABLE ANTENNAS

Frequency Range (GHz)	ANT 4 (dBi)	ANT 3 (dBi)
2.4	-2.3	-0.6

6.6. SOFTWARE AND FIRMWARE

The EUT firmware installed during testing was FW Version: 18.1.148.558

6.7. WORST-CASE CONFIGURATION AND MODE

Radiated band edge, harmonic, and spurious emissions from 1GHz to 18GHz were performed based on the Model A2176 worst case with the EUT set at highest power.

There are two vendors of the WiFi/Bluetooth radio modules: variant 1 and variant 2. The WiFi/Bluetooth radio modules have the same mechanical outline (e.g., the same package dimension and pin-out layout), use the same on-board antenna matching circuit, have an identical antenna structure, and are built and tested to conform to the same specifications and to operate within the same tolerances.

6.8. DESCRIPTION OF TEST SETUP

SUPPORT TEST EQUIPMENT						
Description		Manufacturer	Model	Serial Number	FCC ID/ DoC	
Laptop		Apple	A1398	C02PM012G3QD	DQS-BRCM1069	
Laptop AC/DC adapter		Liteon Technology	PA-1450-BA1	B123	N/A	
EUT AC/DC adapter		Apple	A1385	D29325SM03XDHLHC9	N/A	
I/O CABLES (RF RADIATED TEST)						
Cable No.	Port	# of Identical Ports	Connector Type	Cable Type	Cable Length (m)	Remarks
1	AC	1	AC	Un-shielded	2	N/A
2	USB	1	USB	Un-shielded	1	N/A

TEST SETUP

SETUP DIAGRAM FOR RADIATED TESTS Above 1 GHz

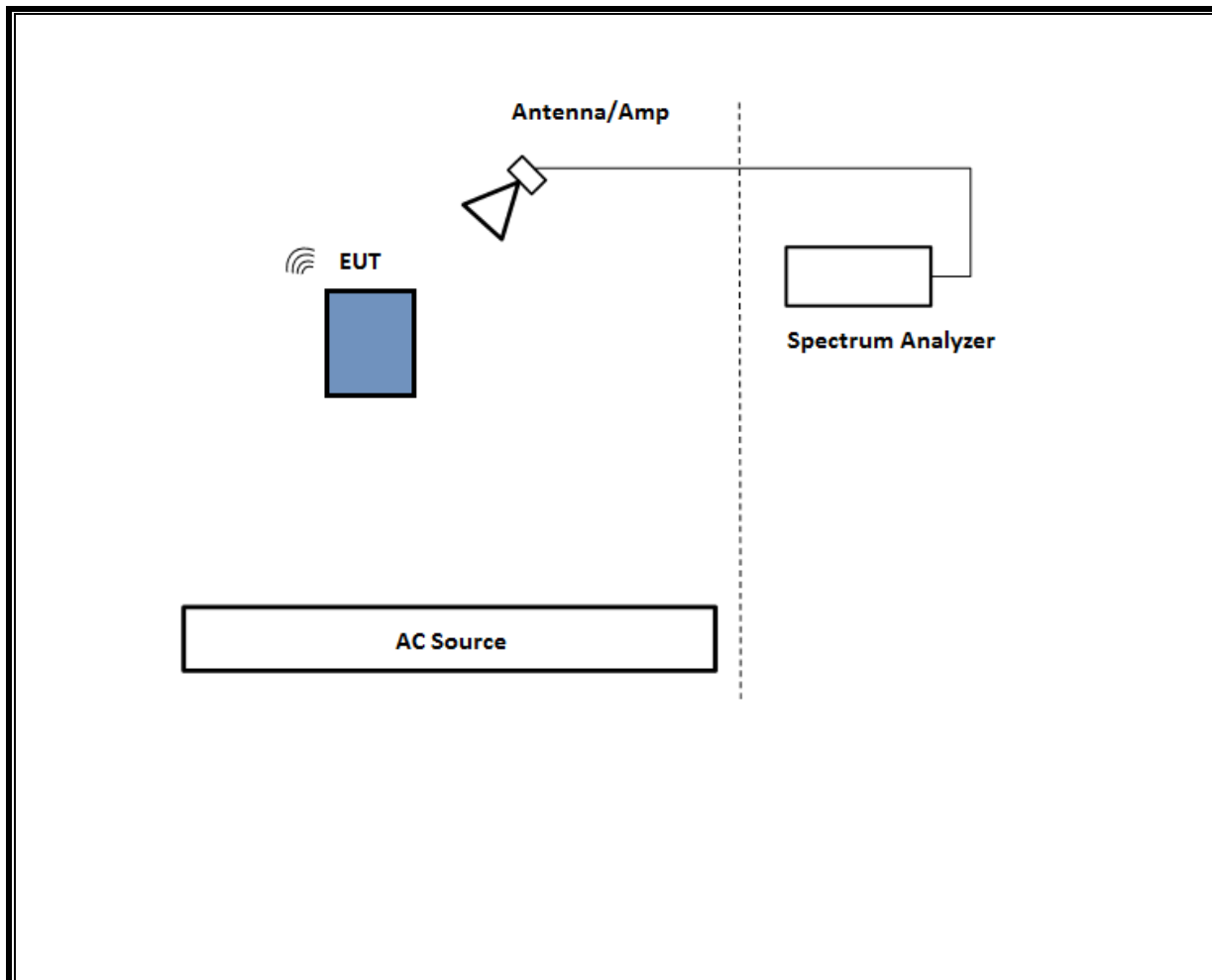

7. MEASUREMENT METHOD

Output Power: ANSI C63.10 Subclause -11.9.1.3 Method PKPM1 Peak-reading power meter

Output Power: ANSI C63.10 Subclause -11.9.2.3.2 Measurement using gated average power meter.

Radiated emissions restricted frequency bands: ANSI C63.10 Subclause -11.12.1 & Clause 13

Band-edge: ANSI C63.10 Subclause -11.13.3.2 & Clause 13: Integration method -Peak detection

Band-edge: ANSI C63.10 Subclause -11.13.3.3 & Clause 13: Integration method -Trace averaging with continuous transmission at full power

Radiated emissions non-restricted frequency bands ANSI C63.10 Subclause – 11.11 & Clause 13

NOTE: All conducted antenna port tests for Beamforming applied the same test procedures as HDR normal modes.

8. TEST AND MEASUREMENT EQUIPMENT

The following test and measurement equipment was utilized for the tests documented in this report:

Description	Manufacturer	Model	ID Num	Cal Due	Last Cal
Antenna, Double Ridge Guide Horn Antenna 700MHz to 18GHz	A.H, Systems Inc.	SAS-571	T963	01/25/2021	01/25/2020
Amplifier, 1 to 18GHz, 35dB	AMPLICAL	AMP1G18-35	T1571	08/20/2021	08/20/2020
EMI Test Receiver	Rohde & Schawrz	ESW44	PRE0179372	02/25/2021	02/25/2020
Antenna, Horn 1-18GHz	ETS-Lindgren	3117	T346	07/20/021	07/20/2020
RF Amplifier, 1-18GHz	MITEQ	AFS42- 00101800-25-S- 42	171460	05/06/2021	05/06/2020
EMI Test Receiver	Rohde & Schawrz	ESW44	PRE0179522	02/20/2021	02/20/2020
UL AUTOMATION SOFTWARE					
Radiated Software	UL	UL EMC	Ver 9.5, Mar 6, 2020		

9. SETUP PHOTOS

Please refer to 13179110-EP1 for setup photos.

END OF TEST REPORT

Appendix A – Reference Test Report

Attached is the test report (13179110-E3) containing the reference data from the parent model as detailed in section 6.4.



TEST REPORT

Report Number: 13179110-E3V2

Applicant : APPLE, INC.
1 APPLE PARK WAY
CUPERTINO, CA 95014, U.S.A

Model : A2176

FCC ID : BCG-E3539A

IC : 579C-E3539A

EUT Description : SMARTPHONE

Test Standard(s) : FCC 47 CFR PART 15 SUBPART C
ISED RSS-247 ISSUE 2
ISED RSS-GEN ISSUE 5

Date of Issue:

September 30, 2020

Prepared by:

UL Verification Services Inc.
47173 Benicia Street
Fremont, CA 94538 U.S.A.
TEL: (510) 319-4000
FAX: (510) 661-0888



NVLAP Lab code: 200065-0

REPORT REVISION HISTORY

Rev.	Issue Date	Revisions	Revised By
V1	9/21/2020	Initial Issue	Vien Tran
V2	9/30/2020	Addressed TCB questions	Francisco Guarnero

TABLE OF CONTENTS

REPORT REVISION HISTORY	2
TABLE OF CONTENTS	3
1. ATTESTATION OF TEST RESULTS	6
2. TEST SUMMARY	7
3. TEST METHODOLOGY	7
4. FACILITIES AND ACCREDITATION	7
5. DECISION RULES AND MEASUREMENT UNCERTAINTY	8
5.1. <i>METROLOGICAL TRACEABILITY</i>	8
5.2. <i>DECISION RULES</i>	8
5.3. <i>MEASUREMENT UNCERTAINTY</i>	8
6. EQUIPMENT UNDER TEST	9
6.1. <i>EUT DESCRIPTION</i>	9
6.2. <i>MAXIMUM OUTPUT POWER</i>	9
6.3. <i>DESCRIPTION OF AVAILABLE ANTENNAS</i>	9
6.4. <i>SOFTWARE AND FIRMWARE</i>	9
6.5. <i>WORST-CASE CONFIGURATION AND MODE</i>	10
6.6. <i>DESCRIPTION OF TEST SETUP</i>	11
7. MEASUREMENT METHOD	16
8. TEST AND MEASUREMENT EQUIPMENT	17
9. ANTENNA PORT TEST RESULTS	18
9.1. <i>ON TIME AND DUTY CYCLE</i>	18
9.2. <i>99% BANDWIDTH</i>	20
9.2.1. <i>HIGH POWER HDR (HDR4)</i>	21
9.2.2. <i>HIGH POWER HDR TXBF (HDR4)</i>	22
9.2.3. <i>HIGH POWER HDR (HDR8)</i>	23
9.2.4. <i>HIGH POWER HDR TXBF (HDR8)</i>	24
9.3. <i>6 dB BANDWIDTH</i>	25
9.3.1. <i>HIGH POWER HDR (HDR4)</i>	26
9.4. <i>OUTPUT POWER</i>	27
9.4.1. <i>HIGH POWER HDR (HDR4)</i>	28
9.4.2. <i>HIGH POWER HDR TXBF (HDR4)</i>	28
9.4.3. <i>HIGH POWER HDR (HDR8)</i>	29
9.4.4. <i>HIGH POWER HDR TXBF (HDR8)</i>	29
9.4.5. <i>LOW POWER HDR (HDR4)</i>	30

9.4.6.	LOW POWER HDR TXBF (HDR4)	30
9.4.7.	LOW POWER HDR (HDR8)	31
9.4.8.	LOW POWER HDR TXBF (HDR8)	31
9.5.	AVERAGE POWER	32
9.5.1.	HIGH POWER HDR (HDR4)	33
9.5.2.	HIGH POWER HDR TXBF (HDR4)	33
9.5.3.	HIGH POWER HDR (HDR8)	34
9.5.4.	HIGH POWER HDR TXBF (HDR8)	34
9.5.5.	LOW POWER HDR (HDR4)	35
9.5.6.	LOW POWER HDR TXBF (HDR4)	35
9.5.7.	LOW POWER HDR (HDR8)	36
9.5.8.	LOW POWER HDR TXBF (HDR8)	36
9.6.	POWER SPECTRAL DENSITY	37
9.6.1.	HIGH POWER HDR (HDR4)	38
9.6.2.	HIGH POWER HDR TXBF (HDR4)	39
9.6.3.	HIGH POWER HDR (HDR8)	40
9.6.4.	HIGH POWER HDR TXBF (HDR8)	41
9.6.5.	LOW POWER HDR (HDR4)	42
9.6.6.	LOW POWER HDR TXBF (HDR4)	43
9.6.7.	LOW POWER HDR (HDR8)	44
9.6.8.	LOW POWER HDR TXBF (HDR8)	45
9.7.	CONDUCTED SPURIOUS EMISSIONS	46
9.7.1.	HIGH POWER HDR (HDR4)	47
9.7.2.	HIGH POWER HDR TXBF (HDR4)	49
9.7.3.	HIGH POWER HDR (HDR8)	51
9.7.4.	HIGH POWER HDR TXBF (HDR8)	53
9.7.5.	LOW POWER HDR (HDR4)	55
9.7.6.	LOW POWER HDR TXBF (HDR4)	57
9.7.7.	LOW POWER HDR (HDR8)	59
9.7.8.	LOW POWER HDR TXBF (HDR8)	61
10.	RADIATED TEST RESULTS	63
10.1.	LIMITS AND PROCEDURE	63
10.2.	TRANSMITTER ABOVE 1 GHz	65
10.2.1.	HIGH POWER HDR (HDR4)	65
10.2.2.	HIGH POWER HDR TXBF (HDR4)	73
10.2.3.	HIGH POWER HDR (HDR8)	77
10.2.4.	HIGH POWER HDR TXBF (HDR8)	85
10.2.5.	LOW POWER HDR (HDR4)	95
10.2.6.	LOW POWER HDR TXBF (HDR4)	103
10.2.7.	LOW POWER HDR (HDR8)	107
10.2.8.	LOW POWER HDR TXBF (HDR8)	115
10.2.9.	HIGH POWER HARMONICS AND SPURIOUS EMISSIONS TXBF HDR8	119
10.3.	WORST CASE BELOW 1 GHz	125
10.4.	WORST CASE 18-26 GHz	127
11.	AC POWER LINE CONDUCTED EMISSIONS	129
11.1.	AC POWER LINE WITH LAPTOP	130

11.2. AC POWER LINE WITH AC/DC ADAPTER 132

12. SETUP PHOTOS 134

1. ATTESTATION OF TEST RESULTS

COMPANY NAME: APPLE INC.
1 APPLE PARK WAY
CUPERTINO, CA 95014, U.S.A

EUT DESCRIPTION: SMARTPHONE

MODEL: A2176

SERIAL NUMBER: C7CD603Z08HK, C7CCT014Q90Y

DATE TESTED: MAY 18, 2020 – SEPTEMBER 2, 2020

APPLICABLE STANDARDS	
STANDARD	TEST RESULTS
CFR 47 Part 15 Subpart C	Complies
ISED RSS-247 Issue 2	Complies
ISED RSS-GEN Issue 5	Complies

UL Verification Services Inc. tested the above equipment in accordance with the requirements set forth in the above standards. The test results show that the equipment tested is capable of demonstrating compliance with the requirements as documented in this report.

The results documented in this report apply only to the tested sample, under the conditions and modes of operation as described herein. It is the manufacturer's responsibility to assure that additional production units of this model are manufactured with identical electrical and mechanical components. All samples tested were in good operating condition throughout the entire test program. Measurement Uncertainties are published for informational purposes only and were not taken into account unless noted otherwise.

This document may not be altered or revised in any way unless done so by UL Verification Services Inc. and all revisions are duly noted in the revisions section. Any alteration of this document not carried out by UL Verification Services Inc. will constitute fraud and shall nullify the document. This report must not be used by the client to claim product certification, approval, or endorsement by NVLAP, NIST, any agency of the Federal Government, or any agency of the U.S. government.

Approved & Released For
UL Verification Services Inc. By:



Chin Pang
Senior Engineer
Consumer Technology Division
UL Verification Services Inc.

Prepared By:



Tony Li
Test Engineer
Consumer Technology Division
UL Verification Services Inc.

2. TEST SUMMARY

FCC Clause	ISED Clause	Requirement	Result	Comment
See Comment		Duty Cycle	Reporting purposes only	ANSI C63.10 Section 11.6.
See Comment	RSS-GEN 6.7	99% OBW	Reporting purposes only	ANSI C63.10 Section 6.9.3.
15.247 (a) (2)	RSS-247 5.2 (a)	6dB BW	Complies	None.
15.247 (b) (3)	RSS-247 5.4 (d)	Output Power	Complies	None.
See Comment		Average power	Reporting purposes only	Per ANSI C63.10, Section 11.9.2.3.2.
15.247 (e)	RSS-247 5.2 (b)	PSD	Complies	None.
15.247 (d)	RSS-247 5.5	Conducted Spurious Emissions	Complies	None.
15.209, 15.205	RSS-GEN 8.9, 8.10	Radiated Emissions	Complies	None.
15.207	RSS-Gen 8.8	AC Mains Conducted Emissions	Complies	None.

3. TEST METHODOLOGY

The tests documented in this report were performed in accordance with FCC CFR 47 Part 2, FCC CFR 47 Part 15, ANSI C63.10-2013, KDB 558074 D01 15.247 Meas Guidance v05r02, KDB662911, RSS-GEN Issue 5, and RSS-247 Issue 2.

4. FACILITIES AND ACCREDITATION

The test sites and measurement facilities used to collect data are located at 47173 and 47266 Benicia Street, and 47658 Kato Road, Fremont, California, USA. Line conducted emissions are measured only at the 47173 address. The following table identifies which facilities were utilized for radiated emission measurements documented in this report. Specific facilities are also identified in the test results sections.

47173 Benicia Street	47266 Benicia Street	47658 Kato Rd.
<input type="checkbox"/> Chamber A (IC:2324B-1)	<input type="checkbox"/> Chamber D (IC:22541-1)	<input checked="" type="checkbox"/> Chamber I (IC: 2324A-5)
<input type="checkbox"/> Chamber B (IC:2324B-2)	<input checked="" type="checkbox"/> Chamber E (IC:22541-2)	<input checked="" type="checkbox"/> Chamber J (IC: 2324A-6)
<input type="checkbox"/> Chamber C (IC:2324B-3)	<input type="checkbox"/> Chamber F (IC:22541-3)	<input type="checkbox"/> Chamber K (IC: 2324A-1)
	<input type="checkbox"/> Chamber G (IC:22541-4)	<input type="checkbox"/> Chamber L (IC: 2324A-3)
	<input type="checkbox"/> Chamber H (IC:22541-5)	<input type="checkbox"/> Chamber M (IC: 2324A-2)

The above test sites and facilities are covered under FCC Test Firm Registration # 208313. Chambers above are covered under Industry Canada company address and respective code.

UL Verification Services Inc. is accredited by NVLAP, Laboratory Code 200065-0.

5. DECISION RULES AND MEASUREMENT UNCERTAINTY

5.1. METROLOGICAL TRACEABILITY

All test and measuring equipment utilized to perform the tests documented in this report are calibrated on a regular basis, with a maximum time between calibrations of one year or the manufacturers' recommendation, whichever is less, and where applicable is traceable to recognized national standards.

5.2. DECISION RULES

The Decision Rule is based on Simple Acceptance in accordance with ISO Guide 98-4:2012 Clause 8.2. (Measurement uncertainty is not taken into account when stating conformity with a specified requirement.)

5.3. MEASUREMENT UNCERTAINTY

Where relevant, the following measurement uncertainty levels have been estimated for tests performed on the apparatus:

PARAMETER	U _{LAB}
Worst Case Conducted Disturbance, 9KHz to 0.15 MHz	3.39 dB
Worst Case Conducted Disturbance, 0.15 to 30 MHz	3.07 dB
Worst Case Radiated Disturbance, 9KHz to 30 MHz	2.52 dB
Worst Case Radiated Disturbance, 30 to 1000 MHz	4.88 dB
Worst Case Radiated Disturbance, 1000 to 18000 MHz	4.24 dB
Worst Case Radiated Disturbance, 18000 to 26000 MHz	4.37 dB
Worst Case Radiated Disturbance, 26000 to 40000 MHz	5.17 dB

Uncertainty figures are valid to a confidence level of 95%.

6. EQUIPMENT UNDER TEST

6.1. EUT DESCRIPTION

The Apple iPhone is a smartphone with multimedia functions (music, application support, and video), cellular GSM, GPRS, EGPRS, UMTS, LTE, 5G, CDMA, IEEE 802.11a/b/g/n/ac/ax, Bluetooth, Ultra-Wideband, GPS, NFC and WPT. All models support at least one UICC based SIM. The second SIM is either an UICC based p-SIM (physical SIM) or e-SIM (electronic SIM). The device supports a built-in inductive charging transmitter and receiver. The rechargeable battery is not user accessible.

6.2. MAXIMUM OUTPUT POWER

The transmitter has a maximum peak conducted output power as follows:

Antenna	Configuration	Frequency Range (MHz)	Mode	Output Power (dBm)	Output Power (mW)
ANT 4	High Power	2404 - 2478	HDR4	14.33	27.10
	Low Power			8.96	7.87
	High Power		HDR8	14.93	31.12
	Low Power			9.38	8.67
ANT 3	High Power	2404 - 2478	HDR4	14.35	27.23
	Low Power			8.98	7.91
	High Power		HDR8	14.94	31.19
	Low Power			9.46	8.83
BF, ANT 4 + ANT 3	High Power	2404 - 2478	HDR4	17.35	54.33
	Low Power			11.98	15.78
	High Power		HDR8	17.94	62.23
	Low Power			12.50	17.78

6.3. DESCRIPTION OF AVAILABLE ANTENNAS

Frequency Range (GHz)	ANT 4 (dBi)	ANT 3 (dBi)
2.4	-2.3	-0.6

6.4. SOFTWARE AND FIRMWARE

The EUT firmware installed during testing was FW Version: 18.1.148.558

6.5. WORST-CASE CONFIGURATION AND MODE

The EUT was investigated in three orthogonal orientations X, Y and Z on both ANT 4 and ANT 3, it was determined that X(Flatbed) orientation was the worst-case orientation for ANT 4, ANT3, and 2TX.

Radiated band edge, harmonic, and spurious emissions from 1GHz to 18GHz were performed with the EUT set to transmit at highest power on Low/Middle/High channels.

Radiated emissions below 1GHz, 18-26GHz and power line conducted emissions were performed with the EUT transmits at the channel with the highest output power as worst-case scenario. There were no emissions found below 30MHz within 20dB of the limit.

For below 1GHz tests were performed with EUT connected to AC power adapter as the worst case; and for above 1GHz, the worst-case configuration reported was tested with EUT only. For AC line conducted emission, test was investigated with AC power adapter and with laptop.

There are two vendors of the WiFi/Bluetooth radio modules: variant 1 and variant 2. The Wi-Fi/Bluetooth radio modules have the same mechanical outline (e.g., the same package dimension and pin-out layout), use the same on-board antenna matching circuit, have an identical antenna structure, and are built and tested to conform to the same specifications and to operate within the same tolerances.

Baseline testing was performed on the two variants to determine the worst case on all conducted power and radiated emissions.

6.6. DESCRIPTION OF TEST SETUP

SUPPORT TEST EQUIPMENT						
Description	Manufacturer	Model	Serial Number	FCC ID/ DoC		
Laptop	Apple	A1398	C02PM012G3QD	DQS-BRCM1069		
Laptop AC/DC adapter	Liteon Technology	PA-1450-BA1	B123	N/A		
EUT AC/DC adapter	Apple	A1385	D29325SM03XDHLHC9	N/A		
I/O CABLES (RF CONDUCTED TEST)						
Cable No.	Port	# of Identical Ports	Connector Type	Cable Type	Cable Length (m)	Remarks
1	Antenna	1	SMA	Un-shielded	0.2	To spectrum Analyzer
2	USB	1	USB	Shielded	1.0	N/A
3	AC	1	AC	Un-shielded	2	N/A
I/O CABLES (RF RADIATED TEST)						
Cable No.	Port	# of Identical Ports	Connector Type	Cable Type	Cable Length (m)	Remarks
1	AC	1	AC	Un-shielded	2	N/A
2	USB	1	USB	Un-shielded	1	N/A

TEST SETUP

The EUT setup is shown as below. Test software exercised the radio card.

SETUP DIAGRAM FOR CONDUCTED TESTS

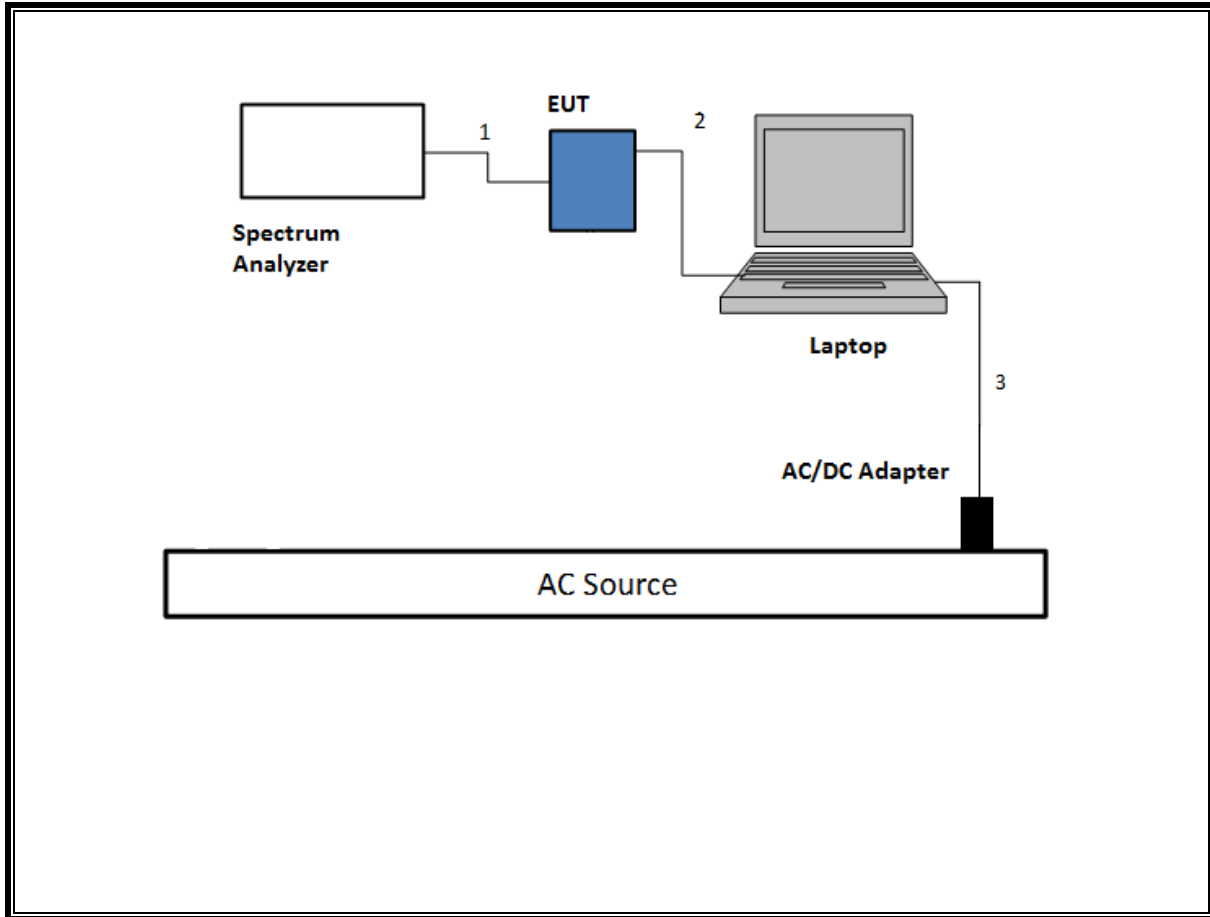

SETUP DIAGRAM FOR RADIATED TESTS Above 1 GHz

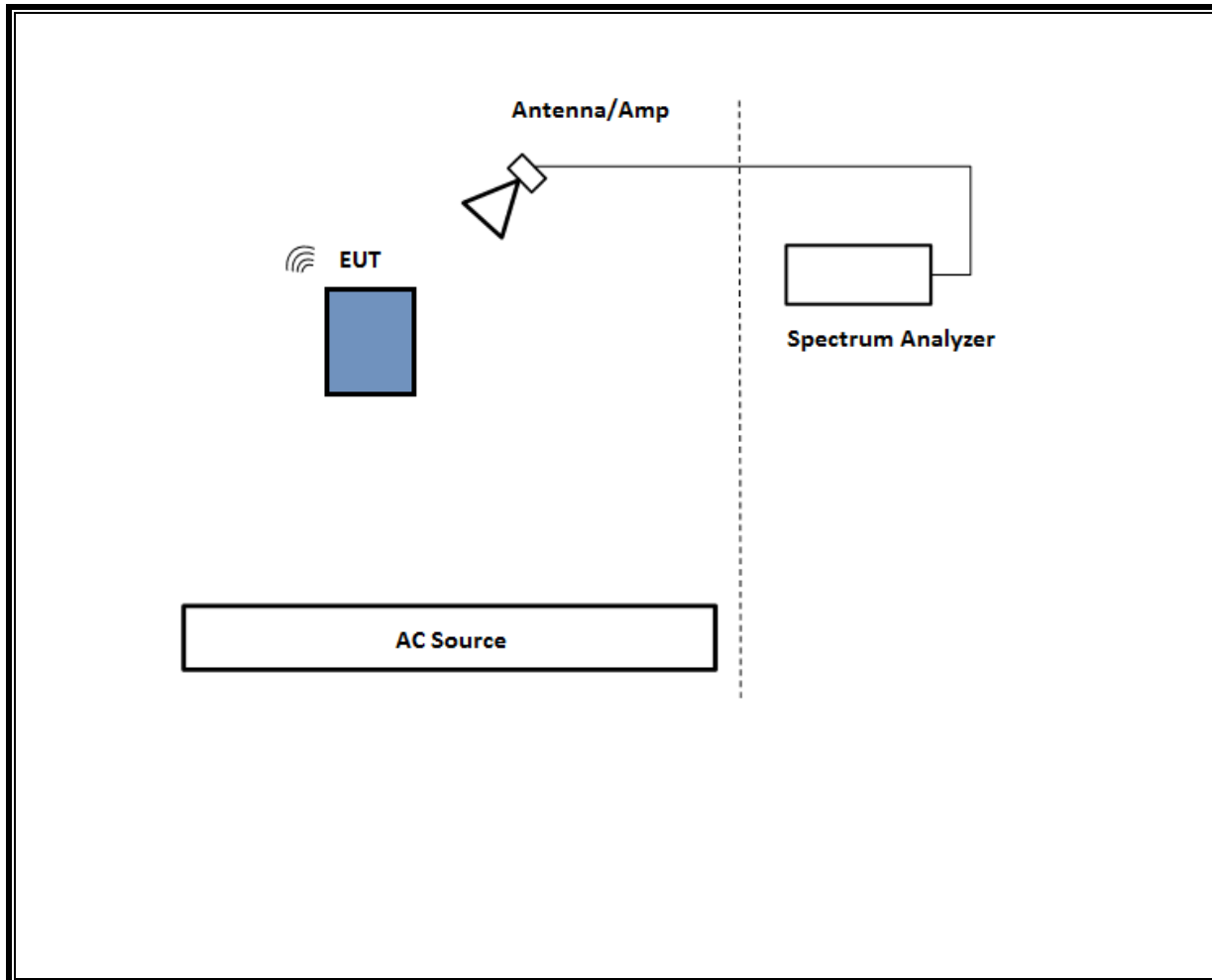

SETUP DIAGRAM FOR Below 1GHz and AC LINE CONDUCTED TEST

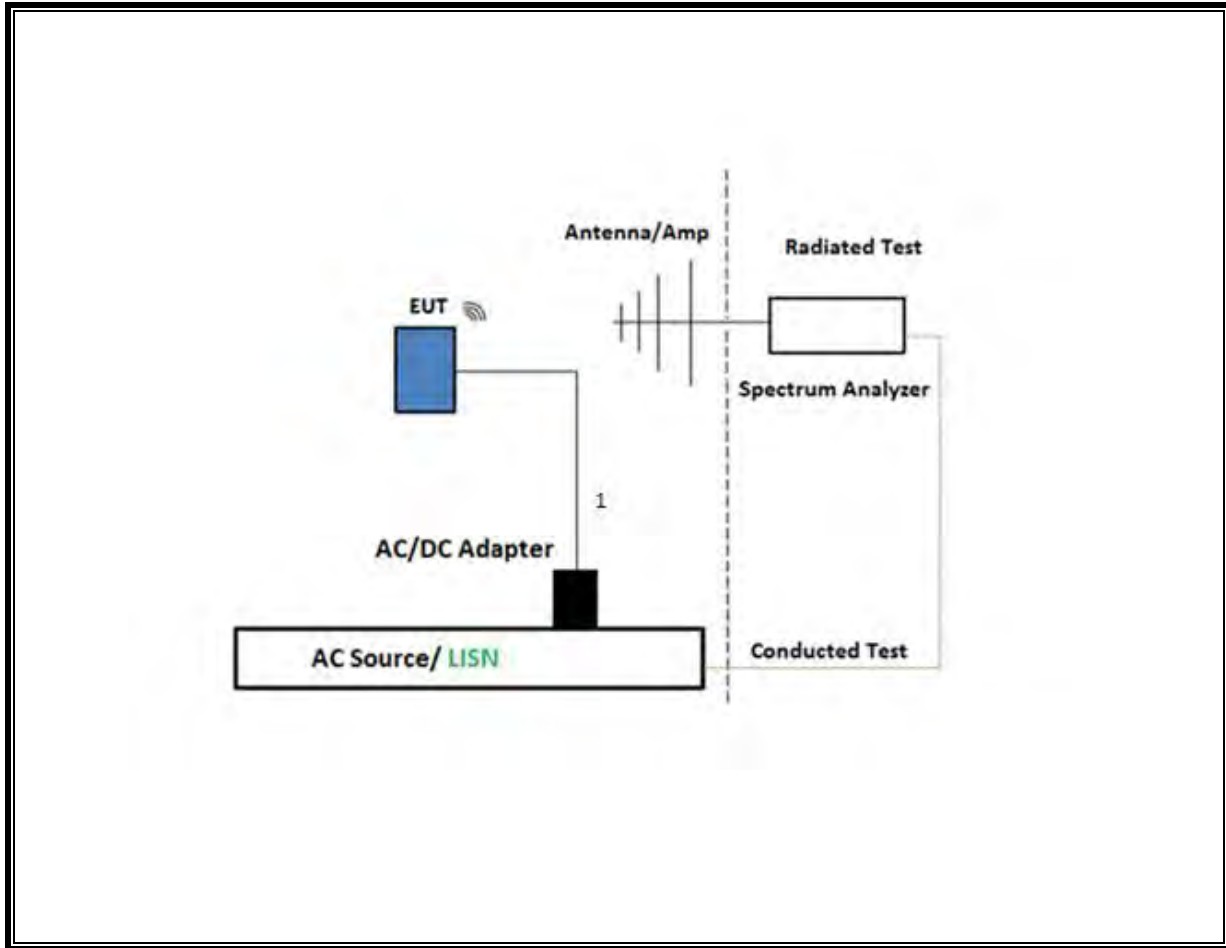

TEST SETUP- AC LINE CONDUCTED: LAPTOP CONFIGURATION

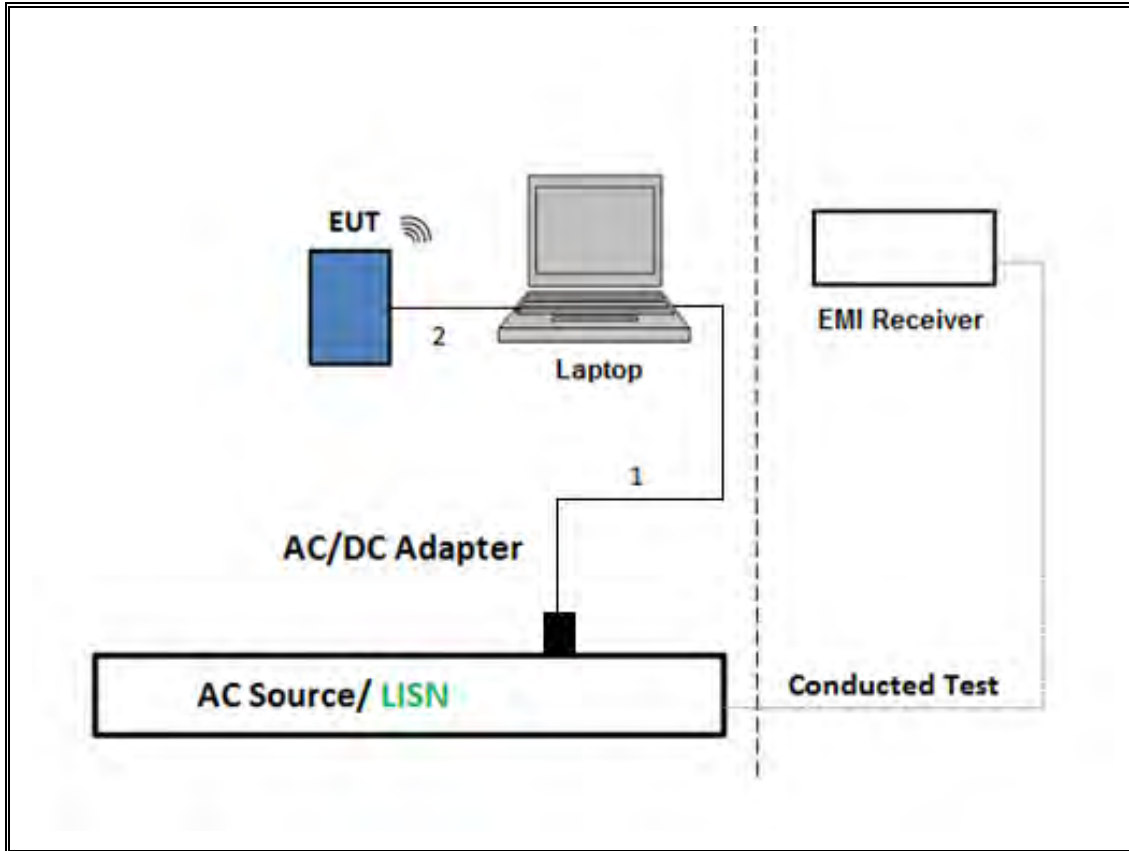

7. MEASUREMENT METHOD

On Time and Duty Cycle: KDB 558074 D01 v05r02, Section 6.

6 dB BW: ANSI C63.10 Subclause -11.8.1 RBW \geq DTS BW

Occupied BW (99%): ANSI C63.10-2013 Section 6.9.3

Output Power: ANSI C63.10 Subclause -11.9.1.3 Method PKPM1 Peak-reading power meter

Output Power: ANSI C63.10 Subclause -11.9.2.3.2 Measurement using gated average power meter.

PSD: ANSI C63.10 Subclause -11.10.2 Method PKPSD (peak PSD)

Radiated emissions restricted frequency bands: ANSI C63.10 Subclause -11.12.1 & Clause 13

Conducted emissions in restricted frequency bands: ANSI C63.10 Subclause -11.12.2

Band-edge: ANSI C63.10 Subclause -11.13.3.2 & Clause 13: Integration method -Peak detection

Band-edge: ANSI C63.10 Subclause -11.13.3.3 & Clause 13: Integration method -Trace averaging with continuous transmission at full power

AC Power Line Conducted Emissions: ANSI C63.10-2013, Section 6.2.

Radiated emissions non-restricted frequency bands: ANSI C63.10 Subclause – 11.11 & Clause 13

Radiated Spurious Emissions Below 30MHz: ANSI C63.10-2013 Section 6.4 & 13

NOTE: All conducted antenna port tests for Beamforming applied the same test procedures as HDR normal modes.

8. TEST AND MEASUREMENT EQUIPMENT

The following test and measurement equipment was utilized for the tests documented in this report:

Description	Manufacturer	Model	ID Num	Cal Due	Last Cal
Antenna, Double Ridge Guide Horn Antenna 700MHz to 18GHz	A.H, Systems Inc.	SAS-571	T963	01/25/2021	01/25/2020
Amplifier, 1 to 18GHz, 35dB	AMPLICAL	AMP1G18-35	T1571	08/20/2021	08/20/2020
EMI Test Receiver	Rohde & Schawrz	ESW44	PRE0179372	02/25/2021	02/25/2020
Antenna, Horn 1-18GHz	ETS-Lindgren	3117	T712	03/09/2021	03/10/2020
Amplifier, 1 to 18GHz, 35dB	AMPLICAL	AMP1G18-35	138301	03/03/2021	03/03/2020
Spectrum Analyzer, PXA, 3Hz to 44GHz	Keysight Technologies Inc	N9030A	T1466	01/23/2021	01/23/2020
*Antenna, Horn 1-18GHz	ETS-Lindgren	3117	T346	07/20/2021	07/20/2020
RF Amplifier, 1-18GHz	MITEQ	AFS42-00101800-25-S-42	171460	05/06/2021	05/06/2020
EMI Test Receiver	Rohde & Schawrz	ESW44	PRE0179522	02/20/2021	02/20/2020
Antenna, Broadband Hybrid, 30MHz to 2000MHz	Sunol Sciences Corp.	JB3	T899	08/23/2020	08/23/2019
*Amplifier, 9kHz to 1GHz, 32dB	SONOMA INSTRUMENT	310	PRE0180174	06/01/2020	06/01/2019
Power Meter, P-series single channel	Keysight	N1911A	PRE0177682	01/21/2021	01/21/2020
Power Sensor	Keysight	N1921A	T1226	02/13/2021	02/13/2020
Antenna Horn, 18 to 26GHz	ARA	SWH-28	T125	04/17/2021	04/17/2020
Pre-Amp 18-26GHz	Agilent Technology	8449B	T404	04/08/2021	04/08/2020
Spectrum Analyzer, PXA, 3Hz to 44GHz	Agilent (Keysight) Technologies	N9030A	T339	01/21/2021	01/21/2020
AC Line Conducted					
Description	Manufacturer	Model	ID Num	Last Cal	Cal Due
EMI Test Receiver 9Khz-7GHz	Rohde & Schwarz	ESCI7	T1436	02/20/2021	02/20/2020
Power Cable, Line Conducted Emissions	UL	PG1	T861	10/27/2020	10/27/2019
LISN for Conducted Emissions CISPR-16	Fischer	50/250-25-2-01	PRE0186446	01/23/2021	01/23/2020
UL AUTOMATION SOFTWARE					
Radiated Software	UL	UL EMC	Ver 9.5, Mar 6, 2020		
Conducted Software	UL	UL EMC	2020.2.26		
AC Line Conducted Software	UL	UL EMC	Ver 9.5, February 21, 2020		

*Testing is completed before equipment expiration date.

9. ANTENNA PORT TEST RESULTS**9.1. ON TIME AND DUTY CYCLE****LIMITS**

None; for reporting purposes only.

PROCEDURE

KDB 558074 Zero-Span Spectrum Analyzer Method.

ON TIME AND DUTY CYCLE RESULTS

Mode	ON Time B (msec)	Period (msec)	Duty Cycle x (linear)	Duty Cycle (%)	Duty Cycle Correction Factor (dB)	1/B Minimum VBW (kHz)
2.4GHz Band						
HDR4	3.76	3.76	1.00	100.0	0.00	0.010
HDR8	3.76	3.76	1.00	100.0	0.00	0.010
HDR4, TXBF	3.44	3.44	1.00	100.0	0.00	0.010
HDR8, TXBF	3.18	3.18	1.00	100.0	0.00	0.010

DUTY CYCLE PLOTS



DUTY CYCLE HDR4



DUTY CYCLE HDR8



DUTY CYCLE HDR4 TXBF



DUTY CYCLE HDR8 TXBF

9.2. 99% BANDWIDTH

LIMITS

None; for reporting purposes only.

RESULTS

Only High Power modes result is reported, it covers all Low Power modes. Only Mid channel plot is reported to show setting parameter complies with testing method/procedure.

9.2.1. HIGH POWER HDR (HDR4)

ANT 4

Channel	Frequency (MHz)	99% Bandwidth (MHz)
Low	2404	2.3002
Middle	2441	2.3385
High	2478	2.3105

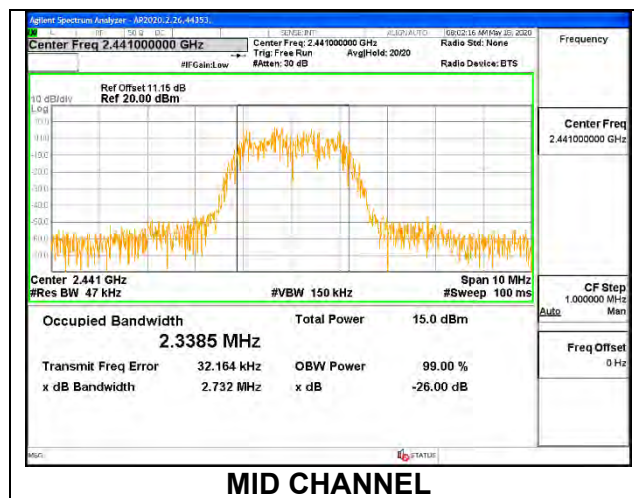

ANT 3

Channel	Frequency (MHz)	99% Bandwidth (MHz)
Low	2404	2.3473
Middle	2441	2.3014
High	2478	2.3007

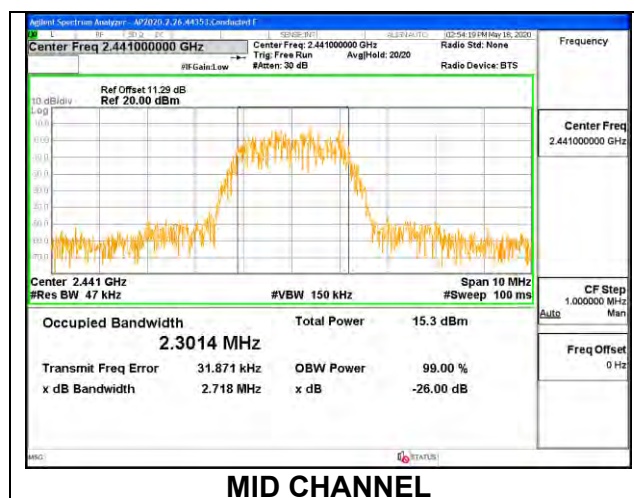

9.2.2. HIGH POWER HDR TXBF (HDR4)

Channel	Frequency (MHz)	99% Bandwidth ANT 4 (MHz)	99% Bandwidth ANT 3 (MHz)
Low	2404	2.3290	2.3454
Middle	2441	2.2955	2.3173
High	2478	2.3226	2.2915

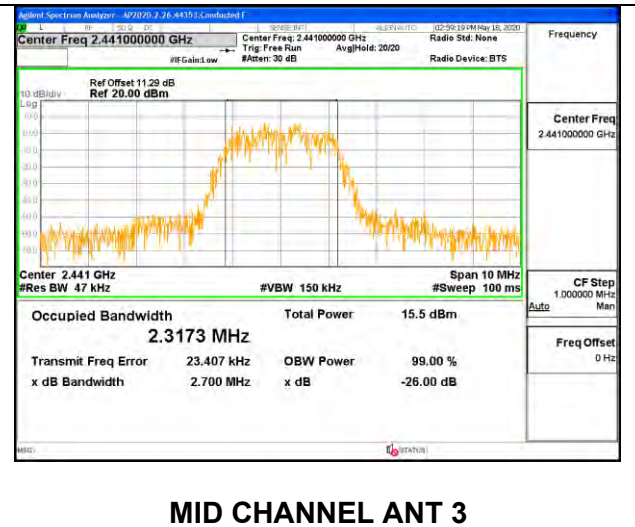
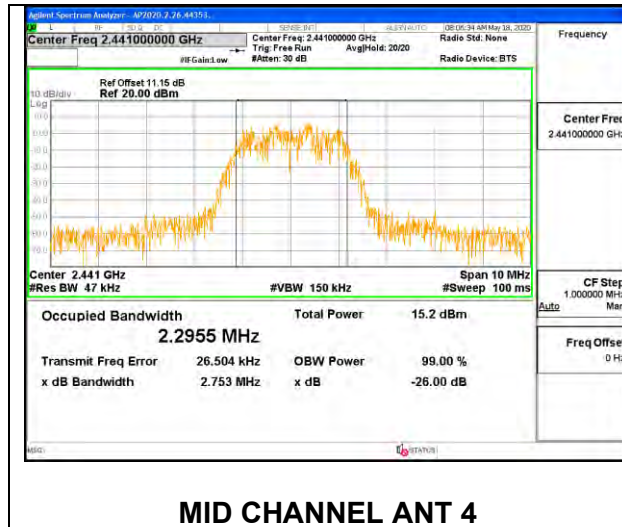

9.2.3. HIGH POWER HDR (HDR8)

ANT 4

Channel	Frequency (MHz)	99% Bandwidth (MHz)
Low	2404	4.6133
Middle	2441	4.6018
High	2478	4.9211

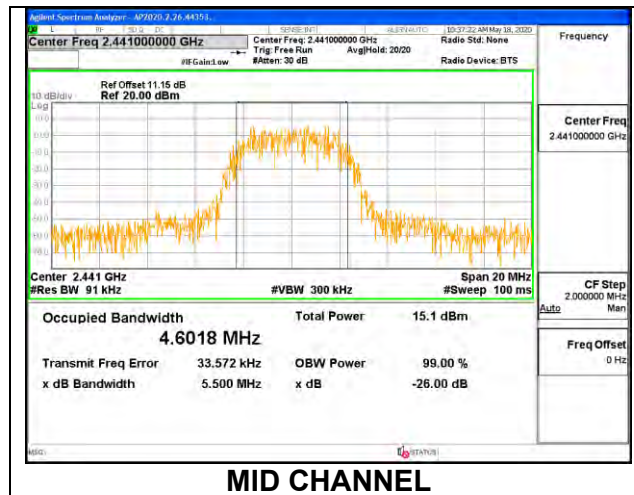

ANT 3

Channel	Frequency (MHz)	99% Bandwidth (MHz)
Low	2404	4.6682
Middle	2441	4.6841
High	2478	4.5723

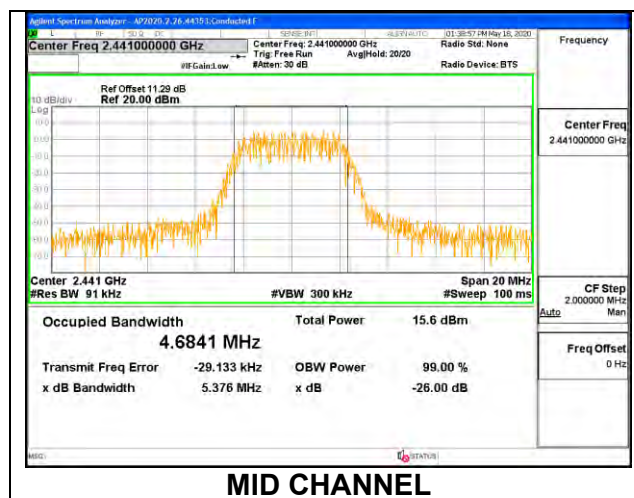

9.2.4. HIGH POWER HDR TXBF (HDR8)

Channel	Frequency (MHz)	99% Bandwidth ANT 4 (MHz)	99% Bandwidth ANT 3 (MHz)
Low	2404	4.6474	4.7328
Middle	2441	4.6879	4.6282
High	2478	4.6566	4.6991

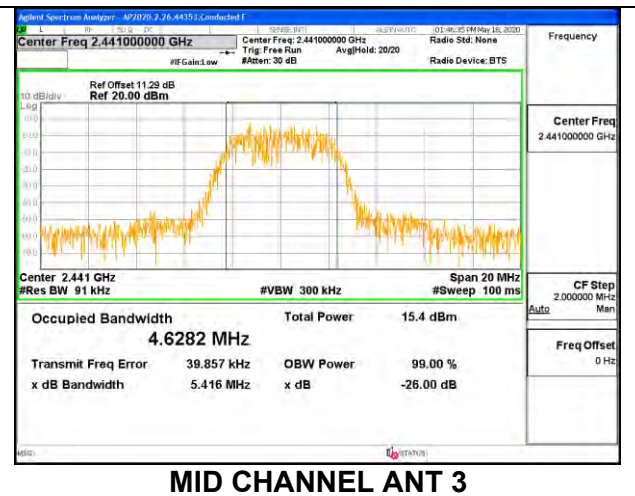
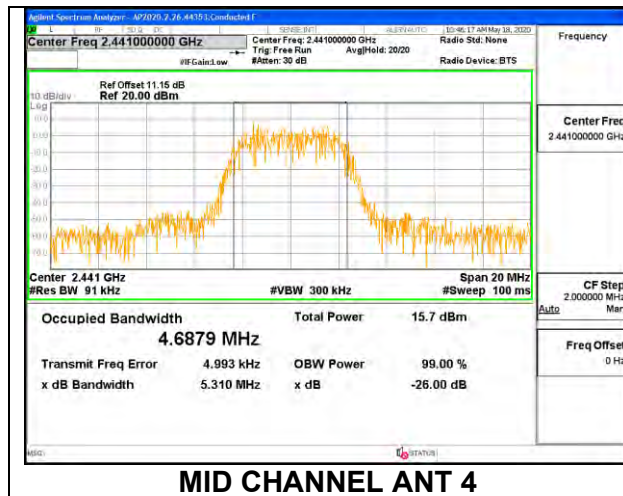

9.3. 6 dB BANDWIDTH

LIMITS

FCC §15.407 (e)

RSS-247 5.2 (a)

The minimum 6 dB bandwidth shall be at least 500 kHz.

RESULTS

The 6dB bandwidth was measured for the narrowest bandwidth mode, High Power HDR4, to demonstrate compliance with the minimum required bandwidth of 500 kHz. Other modes were not tested as their bandwidth is greater than the High Power HDR4 mode, as demonstrated by the 99% bandwidth measurements performed on all modes.

Only Mid channel plot is reported to show setting parameter complies with testing method/procedure.

9.3.1. HIGH POWER HDR (HDR4)

ANT 4

Channel	Frequency (MHz)	6 dB Bandwidth (MHz)	Minimum Limit (MHz)
Low	2404	2.064	0.5
Middle	2441	2.092	0.5
High	2478	2.072	0.5

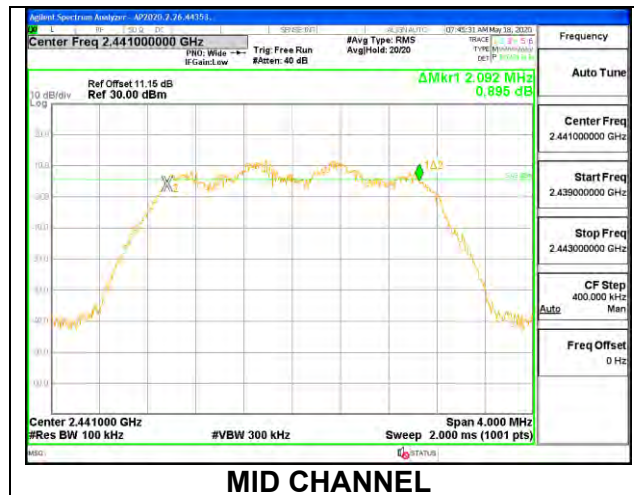

ANT 3

Channel	Frequency (MHz)	6 dB Bandwidth (MHz)	Minimum Limit (MHz)
Low	2404	2.056	0.5
Middle	2441	2.104	0.5
High	2478	2.084	0.5

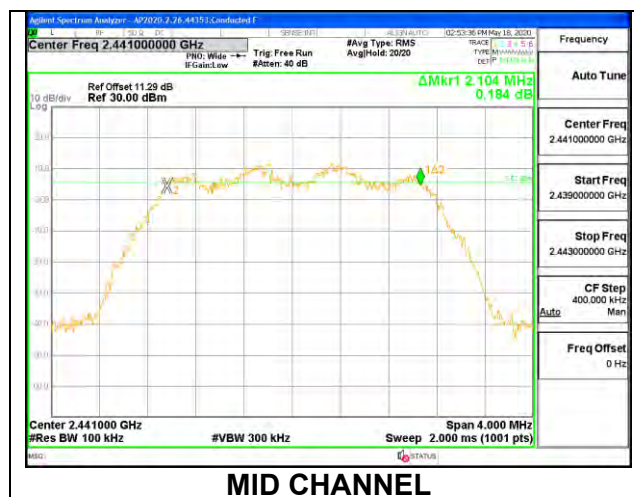

9.4. OUTPUT POWER

LIMITS

FCC §15.247 (b) (3)

RSS-247 5.4 (d)

The maximum antenna gain is less than or equal to 6 dBi, therefore the limit is 30 dBm.

TEST PROCEDURE

The power output was measured on the EUT antenna port using SMA cable with 10dB attenuator connected to a power meter via wideband peak power sensor. Peak output power was read directly from power meter

DIRECTIONAL ANTENNA GAIN

For 1 TX:

There is only one transmitter output therefore the directional gain is equal to the antenna gain.

For 2 TX:

Tx chains are correlated for power and PSD due to the device supporting Beamforming mode. The directional gains are as follows:

Band (GHz)	ANT 4 Antenna Gain (dBi)	ANT 3 Antenna Gain (dBi)	Uncorrelated Chains Directional Gain (dBi)	Correlated Chains Directional Gain (dBi)
2.4	-2.30	-0.60	-1.37	1.60

RESULTS

9.4.1. HIGH POWER HDR (HDR4)

ANT 4

Tested By:	44366
Date:	9/1/2020

Channel	Frequency (MHz)	Peak Power Reading (dBm)	Limit (dBm)	Margin (dB)
Low	2404	14.31	30	-15.69
Middle	2441	14.33	30	-15.67
High	2478	14.24	30	-15.76

ANT 3

Tested By:	44366
Date:	9/2/2020

Channel	Frequency (MHz)	Peak Power Reading (dBm)	Limit (dBm)	Margin (dB)
Low	2404	14.28	30	-15.72
Middle	2441	14.35	30	-15.65
High	2478	14.20	30	-15.80

9.4.2. HIGH POWER HDR TXBF (HDR4)

Tested By:	44366
Date:	9/2/2020

Channel	Frequency (MHz)	Peak Power Reading ANT 4 (dBm)	Peak Power Reading ANT 3 (dBm)	Total Corr'd Power (dBm)	Limit (dBm)	Margin (dB)
Low	2404	14.23	14.32	17.29	30.00	-12.71
Middle	2441	14.32	14.36	17.35	30.00	-12.65
High	2478	14.24	14.31	17.29	30.00	-12.71

9.4.3. HIGH POWER HDR (HDR8)

ANT 4

Tested By:	44366
Date:	9/2/2020

Channel	Frequency (MHz)	Peak Power Reading (dBm)	Limit (dBm)	Margin (dB)
Low	2404	14.82	30	-15.18
Middle	2441	14.93	30	-15.07
High	2478	14.90	30	-15.10

ANT 3

Tested By:	44366
Date:	9/2/2020

Channel	Frequency (MHz)	Peak Power Reading (dBm)	Limit (dBm)	Margin (dB)
Low	2404	14.83	30	-15.17
Middle	2441	14.94	30	-15.06
High	2478	14.88	30	-15.12

9.4.4. HIGH POWER HDR TXBF (HDR8)

Tested By:	44366
Date:	9/2/2020

Channel	Frequency (MHz)	Peak Power Reading ANT 4 (dBm)	Peak Power Reading ANT 3 (dBm)	Total Corr'd Power (dBm)	Limit (dBm)	Margin (dB)
Low	2404	14.86	14.88	17.88	30.00	-12.12
Middle	2441	14.89	14.96	17.94	30.00	-12.06
High	2478	14.82	14.83	17.84	30.00	-12.16

9.4.5. LOW POWER HDR (HDR4)

ANT 4

Tested By:	44366
Date:	9/2/2020

Channel	Frequency (MHz)	Peak Power Reading (dBm)	Limit (dBm)	Margin (dB)
Low	2404	8.91	30	-21.09
Middle	2441	8.96	30	-21.04
High	2478	8.88	30	-21.12

ANT 3

Tested By:	44366
Date:	9/2/2020

Channel	Frequency (MHz)	Peak Power Reading (dBm)	Limit (dBm)	Margin (dB)
Low	2404	8.92	30	-21.08
Middle	2441	8.98	30	-21.02
High	2478	8.93	30	-21.07

9.4.6. LOW POWER HDR TXBF (HDR4)

Tested By:	44366
Date:	9/2/2020

Channel	Frequency (MHz)	Peak Power Reading ANT 4 (dBm)	Peak Power Reading ANT 3 (dBm)	Total Corr'd Power (dBm)	Limit (dBm)	Margin (dB)
Low	2404	8.95	8.86	11.92	30.00	-18.08
Middle	2441	8.96	8.97	11.98	30.00	-18.02
High	2478	8.86	8.93	11.91	30.00	-18.09

9.4.7. LOW POWER HDR (HDR8)

ANT 4

Tested By:	44366
Date:	9/2/2020

Channel	Frequency (MHz)	Peak Power Reading (dBm)	Limit (dBm)	Margin (dB)
Low	2404	9.37	30	-20.63
Middle	2441	9.38	30	-20.62
High	2478	9.34	30	-20.66

ANT 3

Tested By:	44366
Date:	9/2/2020

Channel	Frequency (MHz)	Peak Power Reading (dBm)	Limit (dBm)	Margin (dB)
Low	2404	9.42	30	-20.58
Middle	2441	9.46	30	-20.54
High	2478	9.34	30	-20.66

9.4.8. LOW POWER HDR TXBF (HDR8)

Tested By:	44366
Date:	9/2/2020

Channel	Frequency (MHz)	Peak Power Reading ANT 4 (dBm)	Peak Power Reading ANT 3 (dBm)	Total Corr'd Power (dBm)	Limit (dBm)	Margin (dB)
Low	2404	9.45	9.46	12.47	30.00	-17.53
Middle	2441	9.50	9.48	12.50	30.00	-17.50
High	2478	9.41	9.39	12.41	30.00	-17.59

9.5. AVERAGE POWER

LIMITS

None; for reporting purposes only.

TEST PROCEDURE

The power output was measured on the EUT antenna port using SMA cable with 10dB attenuator connected to a power meter via wideband average power sensor. Gated average output power was read directly from power meter.

RESULTS

9.5.1. HIGH POWER HDR (HDR4)

ANT 4

Tested By:	44366
Date:	9/1/2020

Channel	Frequency (MHz)	AV power (dBm)
Low	2404	11.86
Middle	2441	11.94
High	2478	11.82

ANT 3

Tested By:	44366
Date:	9/2/2020

Channel	Frequency (MHz)	AV power (dBm)
Low	2404	11.80
Middle	2441	11.90
High	2478	11.84

9.5.2. HIGH POWER HDR TXBF (HDR4)

Tested By:	44366
Date:	9/2/2020

Channel	Frequency (MHz)	Average Power ANT 4 (dBm)	Average Power ANT 3 (dBm)	Total Power (dBm)
Low	2404	11.84	11.86	14.86
Middle	2441	11.90	11.93	14.93
High	2478	11.88	11.84	14.87

9.5.3. HIGH POWER HDR (HDR8)

ANT 4

Tested By:	44366
Date:	9/2/2020

Channel	Frequency (MHz)	AV power (dBm)
Low	2404	11.85
Middle	2441	11.90
High	2478	11.82

ANT 3

Tested By:	44366
Date:	9/2/2020

Channel	Frequency (MHz)	AV power (dBm)
Low	2404	11.80
Middle	2441	11.94
High	2478	11.84

9.5.4. HIGH POWER HDR TXBF (HDR8)

Tested By:	44366
Date:	9/2/2020

Channel	Frequency (MHz)	Average Power ANT 4 (dBm)	Average Power ANT 3 (dBm)	Total Power (dBm)
Low	2404	11.85	11.84	14.86
Middle	2441	11.92	11.88	14.91
High	2478	11.88	11.85	14.88

9.5.5. LOW POWER HDR (HDR4)

ANT 4

Tested By:	44366
Date:	9/2/2020

Channel	Frequency (MHz)	AV power (dBm)
Low	2404	6.41
Middle	2441	6.44
High	2478	6.37

ANT 3

Tested By:	44366
Date:	9/2/2020

Channel	Frequency (MHz)	AV power (dBm)
Low	2404	6.41
Middle	2441	6.49
High	2478	6.30

9.5.6. LOW POWER HDR TXBF (HDR4)

Tested By:	44366
Date:	9/2/2020

Channel	Frequency (MHz)	Average Power ANT 4 (dBm)	Average Power ANT 3 (dBm)	Total Power (dBm)
Low	2404	6.37	6.34	9.37
Middle	2441	6.41	6.36	9.40
High	2478	6.35	6.30	9.34

9.5.7. LOW POWER HDR (HDR8)

ANT 4

Tested By:	44366
Date:	9/2/2020

Channel	Frequency (MHz)	AV power (dBm)
Low	2404	6.36
Middle	2441	6.40
High	2478	6.30

ANT 3

Tested By:	44366
Date:	9/2/2020

Channel	Frequency (MHz)	AV power (dBm)
Low	2404	6.40
Middle	2441	6.45
High	2478	6.37

9.5.8. LOW POWER HDR TXBF (HDR8)

Tested By:	44366
Date:	9/2/2020

Channel	Frequency (MHz)	Average Power ANT 4 (dBm)	Average Power ANT 3 (dBm)	Total Power (dBm)
Low	2404	6.43	6.44	9.45
Middle	2441	6.46	6.47	9.48
High	2478	6.38	6.35	9.38

9.6. POWER SPECTRAL DENSITY

LIMITS

FCC §15.247 (e)

RSS-247 (5.2) (b)

The power spectral density conducted from the transmitter to the antenna shall not be greater than 8 dBm in any 3 kHz band during any time interval of continuous transmission.

RESULTS

Only Mid channel plot is reported to show setting parameter complies with testing method/procedure.

9.6.1. HIGH POWER HDR (HDR4)

ANT 4

Channel	Frequency (MHz)	PSD (dBm/3kHz)	Limit (dBm/3kHz)	Margin (dB)
Low	2404	-0.669	8	-8.67
Middle	2441	-1.578	8	-9.58
High	2478	-3.164	8	-11.16

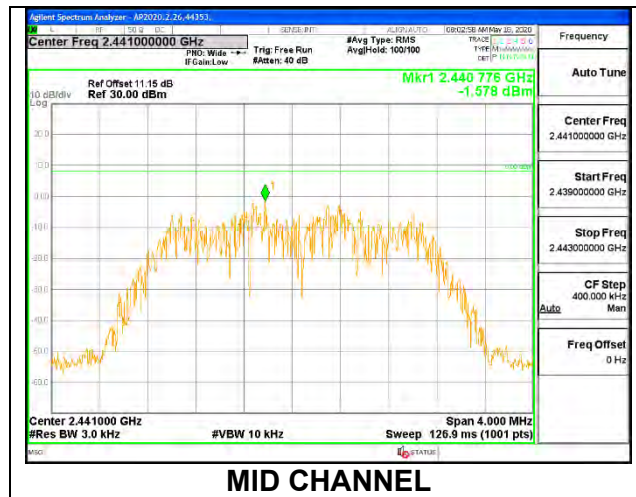

ANT 3

Channel	Frequency (MHz)	PSD (dBm/3kHz)	Limit (dBm/3kHz)	Margin (dB)
Low	2404	-1.107	8	-9.11
Middle	2441	-1.396	8	-9.40
High	2478	-1.153	8	-9.15

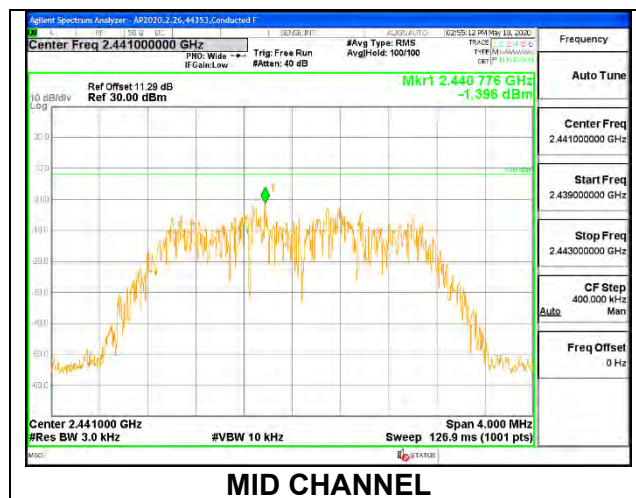

9.6.2. HIGH POWER HDR TXBF (HDR4)

Note: Test procedures and setting are same as HDR normal mode.

PSD Results

Channel	Frequency (MHz)	ANT 4 Meas (dBm/ 3kHz)	ANT 3 Meas (dBm/ 3kHz)	Total Corr'd PSD (dBm/ 3kHz)	Limit (dBm/ 3kHz)	Margin (dB)
Low	2404	-0.683	-1.300	2.03	8.0	-6.0
Mid	2441	-1.578	-1.410	1.52	8.0	-6.5
High	2478	-3.182	-1.096	1.00	8.0	-7.0

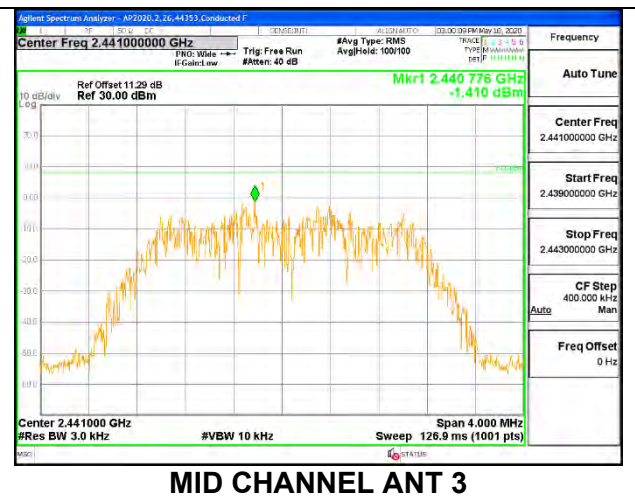
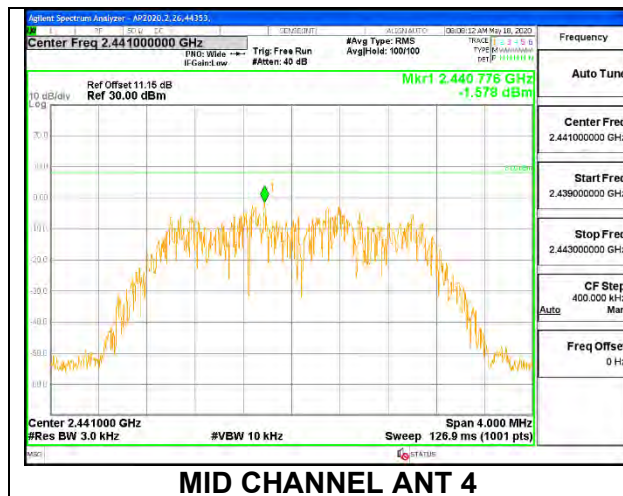

9.6.3. HIGH POWER HDR (HDR8)

ANT 4

Channel	Frequency (MHz)	PSD (dBm/3kHz)	Limit (dBm/3kHz)	Margin (dB)
Low	2404	-3.129	8	-11.13
Middle	2441	-3.919	8	-11.92
High	2478	-5.495	8	-13.50

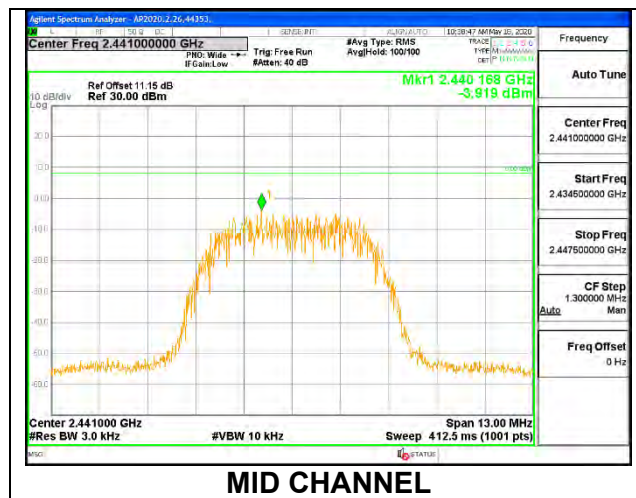

ANT 3

Channel	Frequency (MHz)	PSD (dBm/3kHz)	Limit (dBm/3kHz)	Margin (dB)
Low	2404	-3.657	8	-11.66
Middle	2441	-3.754	8	-11.75
High	2478	-3.521	8	-11.52

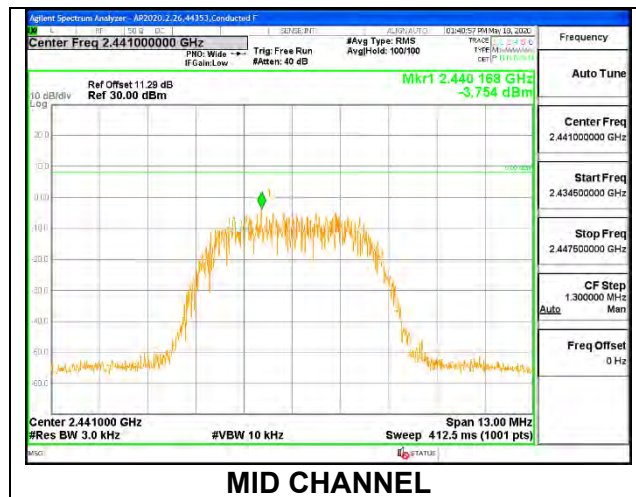

9.6.4. HIGH POWER HDR TXBF (HDR8)

Note: Test procedures and setting are same as HDR normal mode.

PSD Results

Channel	Frequency (MHz)	ANT 4 Meas (dBm/ 3kHz)	ANT 3 Meas (dBm/ 3kHz)	Total Corr'd PSD (dBm/ 3kHz)	Limit (dBm/ 3kHz)	Margin (dB)
Low	2404	-3.129	-3.735	-0.41	8.0	-8.4
Mid	2441	-3.895	-3.730	-0.80	8.0	-8.8
High	2478	-5.492	-3.538	-1.40	8.0	-9.4

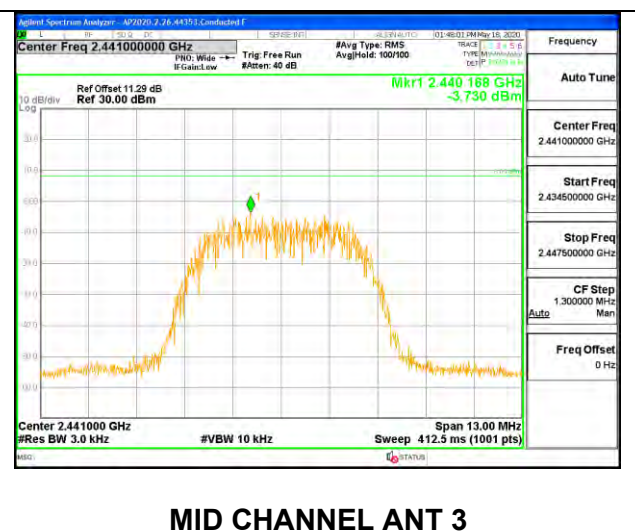
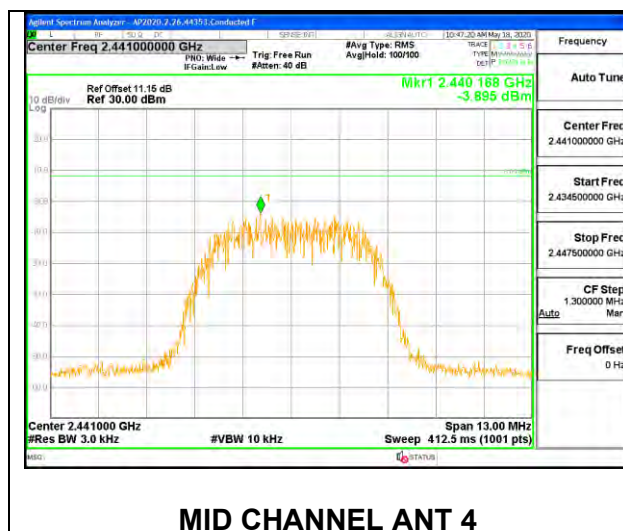

9.6.5. LOW POWER HDR (HDR4)

ANT 4

Channel	Frequency (MHz)	PSD (dBm/3kHz)	Limit (dBm/3kHz)	Margin (dB)
Low	2404	-10.155	8	-18.16
Middle	2441	-9.838	8	-17.84
High	2478	-10.929	8	-18.93

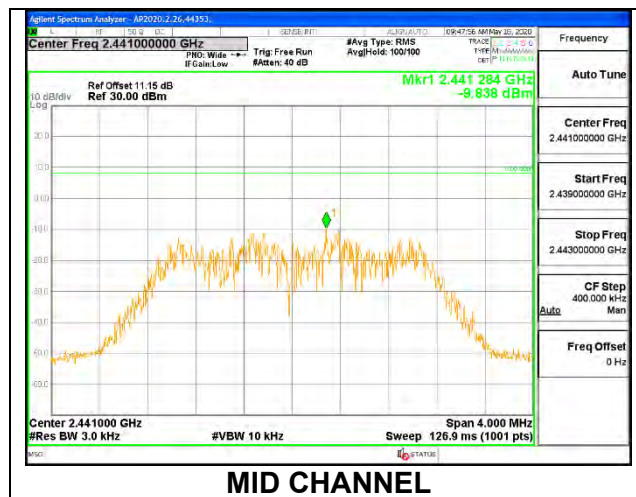

ANT 3

Channel	Frequency (MHz)	PSD (dBm/3kHz)	Limit (dBm/3kHz)	Margin (dB)
Low	2404	-11.537	8	-19.54
Middle	2441	-11.340	8	-19.34
High	2478	-12.471	8	-20.47

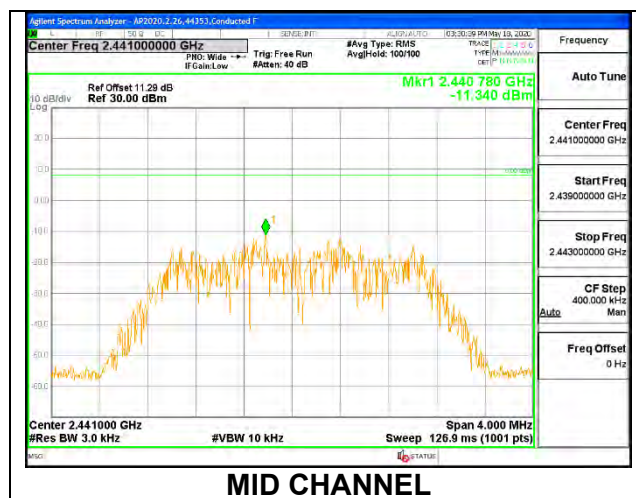

9.6.6. LOW POWER HDR TXBF (HDR4)

Note: Test procedures and setting are same as HDR normal mode.

PSD Results

Channel	Frequency (MHz)	ANT 4 Meas (dBm/ 3kHz)	ANT 3 Meas (dBm/ 3kHz)	Total Corr'd PSD (dBm/ 3kHz)	Limit (dBm/ 3kHz)	Margin (dB)
Low	2404	-10.167	-11.584	-7.81	8.0	-15.8
Mid	2441	-9.851	-11.316	-7.51	8.0	-15.5
High	2478	-11.058	-12.217	-8.59	8.0	-16.6

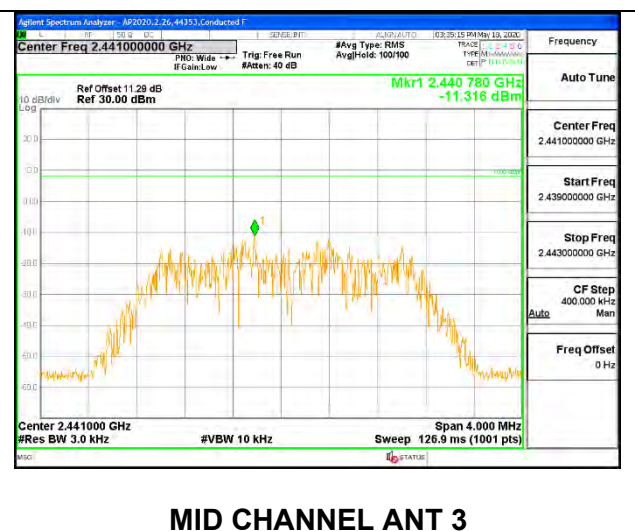
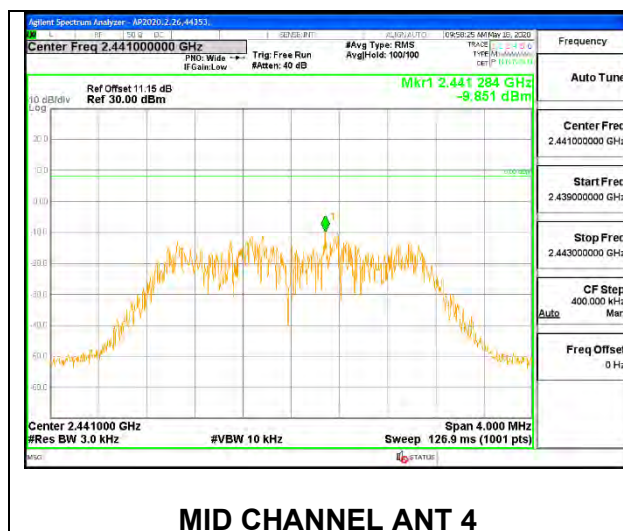

9.6.7. LOW POWER HDR (HDR8)

ANT 4

Channel	Frequency (MHz)	PSD (dBm/3kHz)	Limit (dBm/3kHz)	Margin (dB)
Low	2404	-12.714	8	-20.71
Middle	2441	-12.130	8	-20.13
High	2478	-13.356	8	-21.36

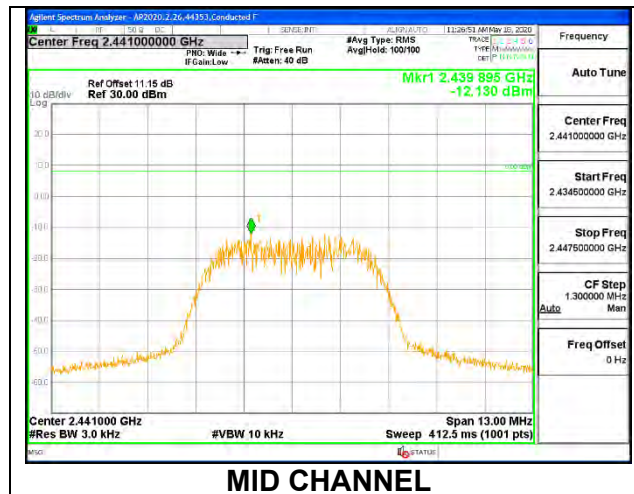

ANT 3

Channel	Frequency (MHz)	PSD (dBm/3kHz)	Limit (dBm/3kHz)	Margin (dB)
Low	2404	-13.971	8	-21.97
Middle	2441	-13.701	8	-21.70
High	2478	-14.515	8	-22.52

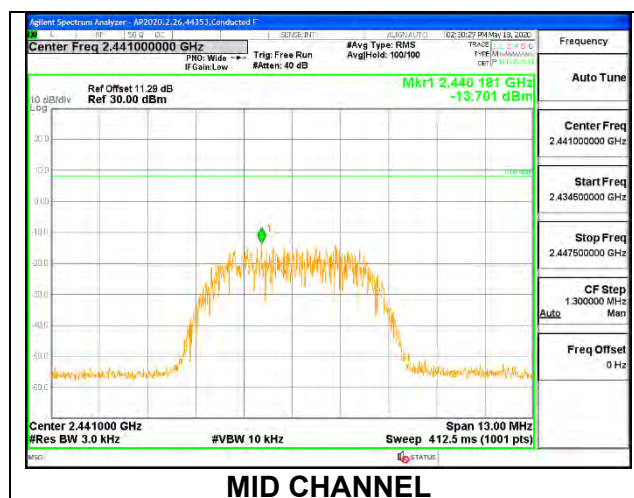

9.6.8. LOW POWER HDR TXBF (HDR8)

Note: Test procedures and setting are same as HDR normal mode.

PSD Results

Channel	Frequency (MHz)	ANT 4 Meas (dBm/ 3kHz)	ANT 3 Meas (dBm/ 3kHz)	Total Corr'd PSD (dBm/ 3kHz)	Limit (dBm/ 3kHz)	Margin (dB)
Low	2404	-12.710	-13.992	-10.29	8.0	-18.3
Mid	2441	-12.146	-13.744	-9.86	8.0	-17.9
High	2478	-13.306	-14.372	-10.80	8.0	-18.8

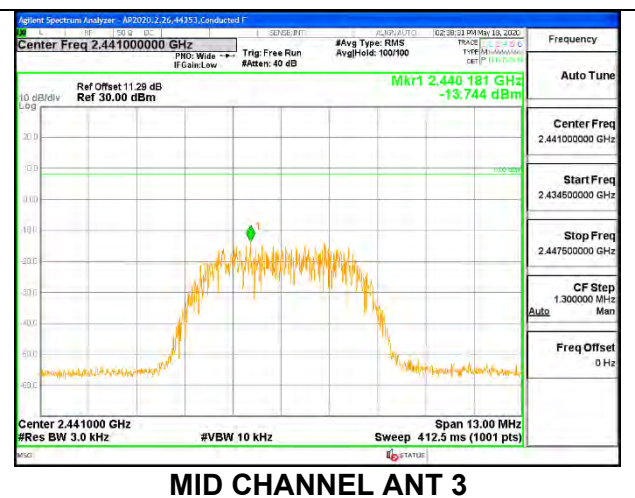
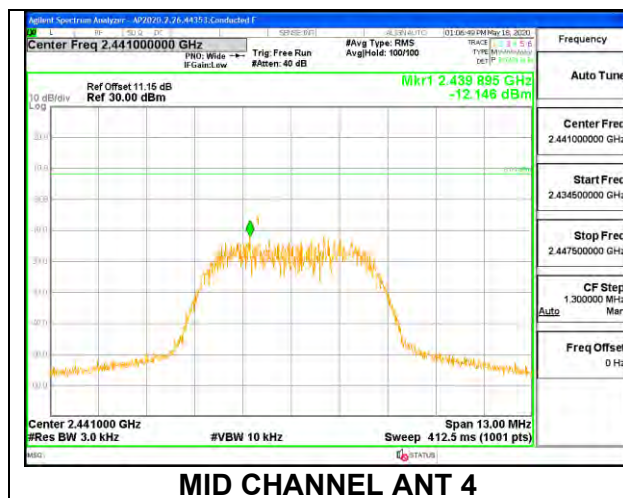

9.7. CONDUCTED SPURIOUS EMISSIONS

LIMITS

FCC §15.247 (d)

RSS-247 5.5

Output power was measured based on the use of a peak measurement; therefore, spurious emissions are required to be 20dBc.

RESULTS

9.7.1. HIGH POWER HDR (HDR4)

ANT 4



LOW CHANNEL BANDEDGE



OUT-OF-BAND LOW CHANNEL

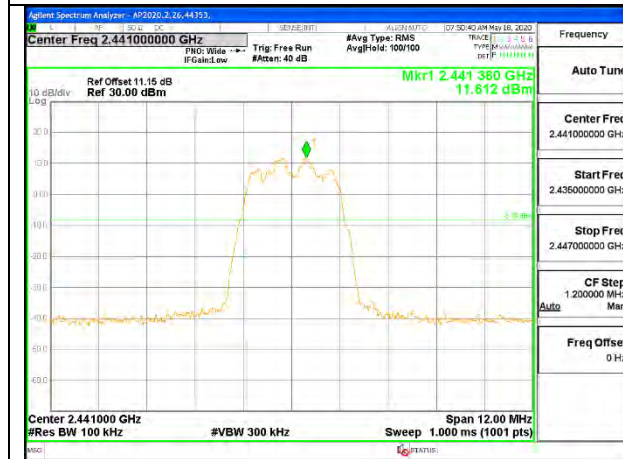

MID CHANNEL REFERENCE LEVEL

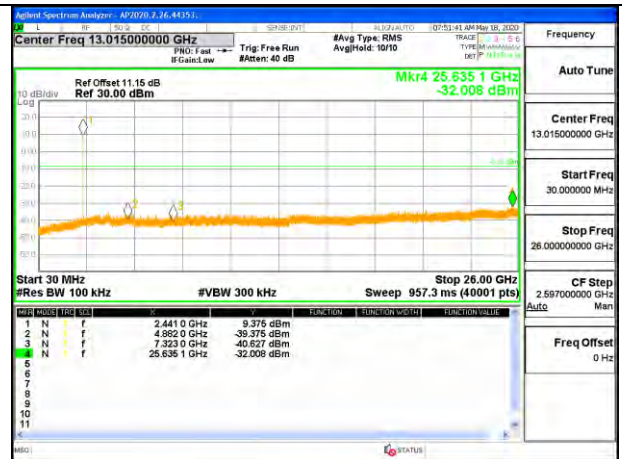

OUT-OF-BAND MID CHANNEL



HIGH CHANNEL BANDEDGE

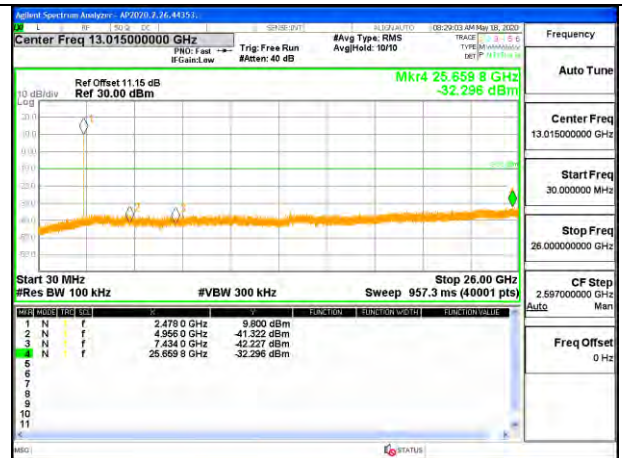

OUT-OF-BAND HIGH CHANNEL

ANT 3



LOW CHANNEL BANDEDGE

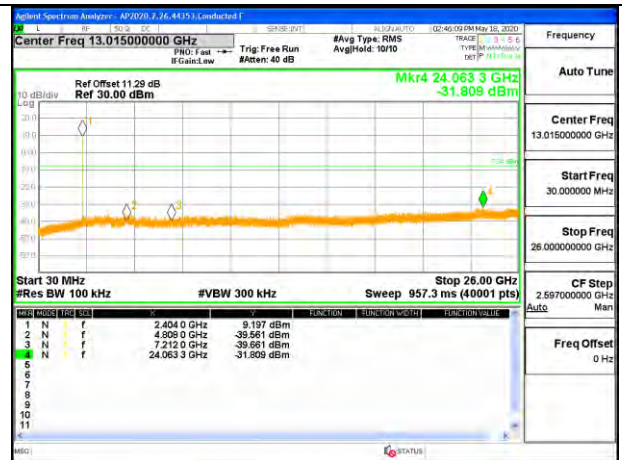

OUT-OF-BAND LOW CHANNEL



IN-BAND REFERENCE LEVEL

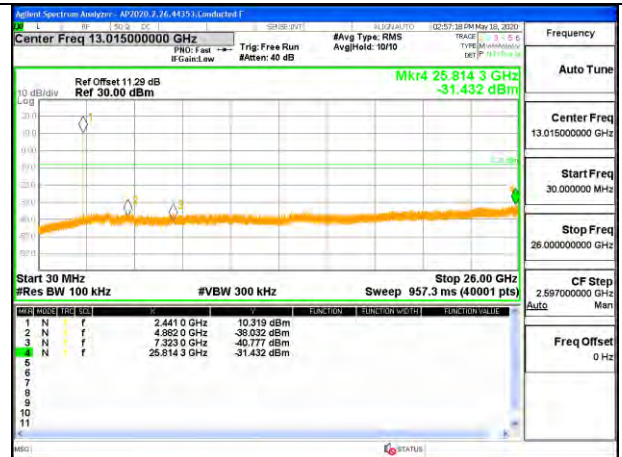

OUT-OF-BAND MID CHANNEL



HIGH CHANNEL BANDEDGE

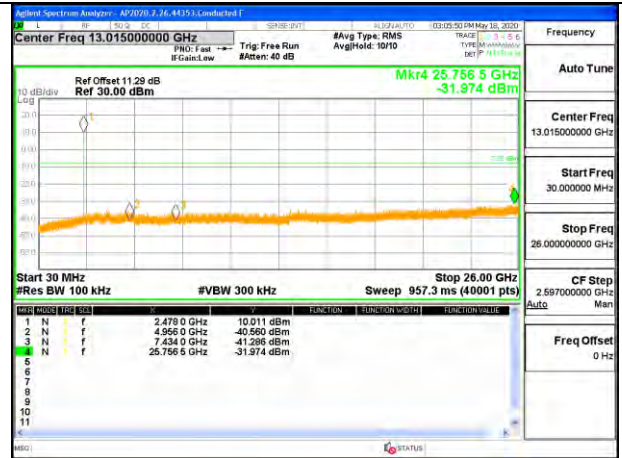

OUT-OF-BAND HIGH CHANNEL

9.7.2. HIGH POWER HDR TXBF (HDR4)

ANT 4



LOW CHANNEL BANDEDGE ANT 4

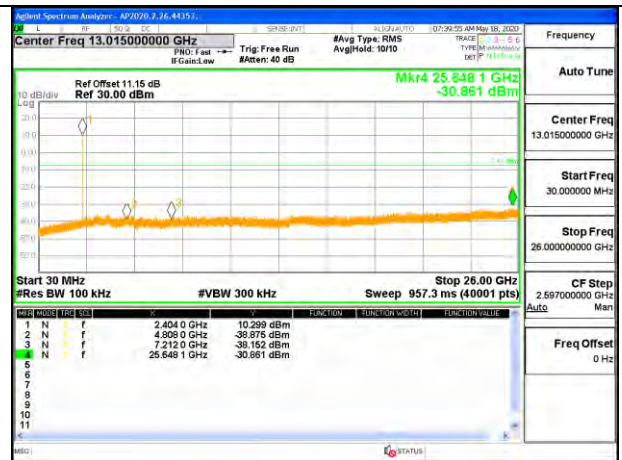

OUT-OF-BAND LOW CHANNEL ANT 4



MID CHANNEL REFERENCE LEVEL ANT 4

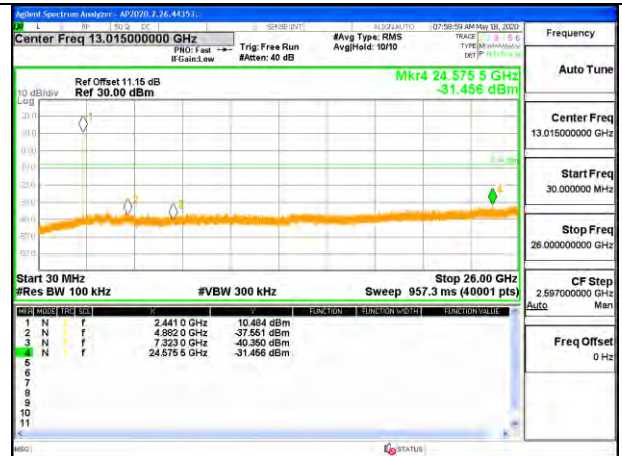

OUT-OF-BAND MID CHANNEL ANT 4



HIGH CHANNEL BANDEDGE ANT 4

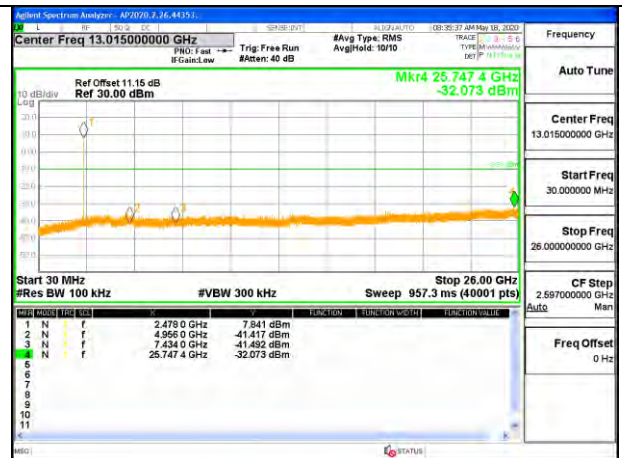

OUT-OF-BAND HIGH CHANNEL ANT 4

ANT 3



LOW CHANNEL BANDEDGE ANT 3

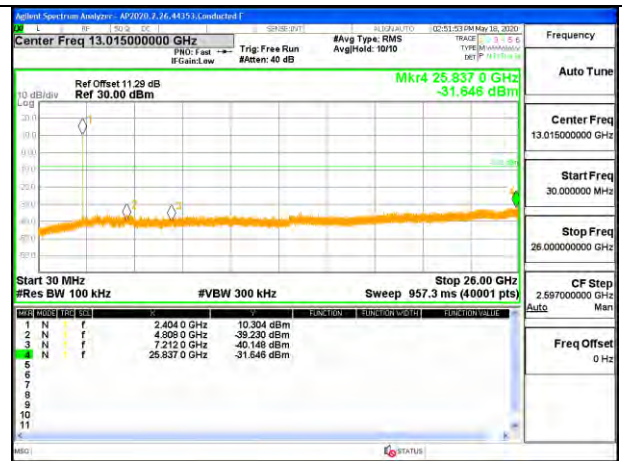

UT-OF-BAND LOW CHANNEL ANT 3



IN-BAND REFERENCE LEVEL ANT 3



OUT-OF-BAND MID CHANNEL ANT 3



HIGH CHANNEL BANDEDGE ANT 3

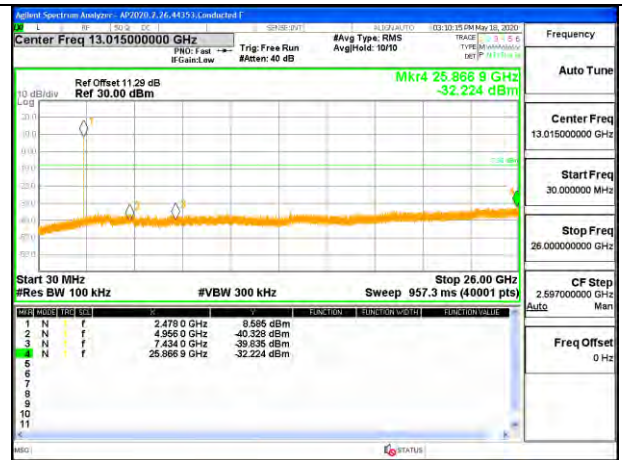

OUT-OF-BAND HIGH CHANNEL ANT 3

9.7.3. HIGH POWER HDR (HDR8)

ANT 4

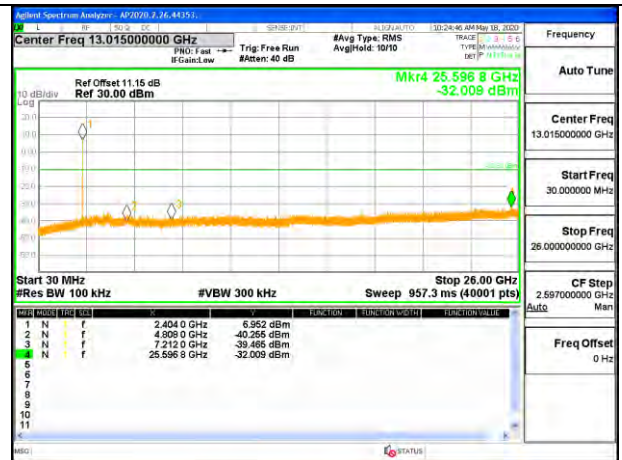

LOW CHANNEL BANDEDGE

OUT-OF-BAND LOW CHANNEL

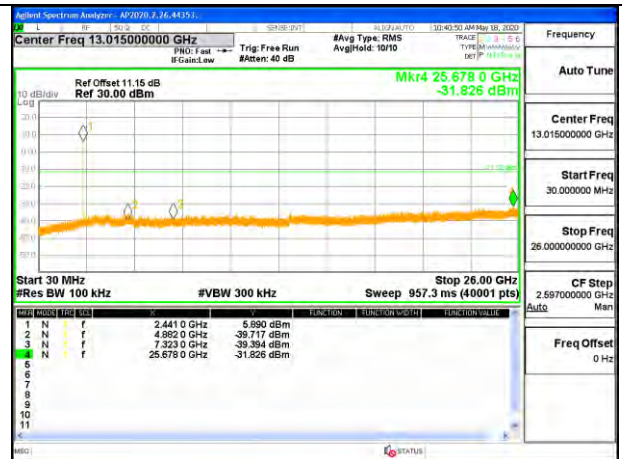
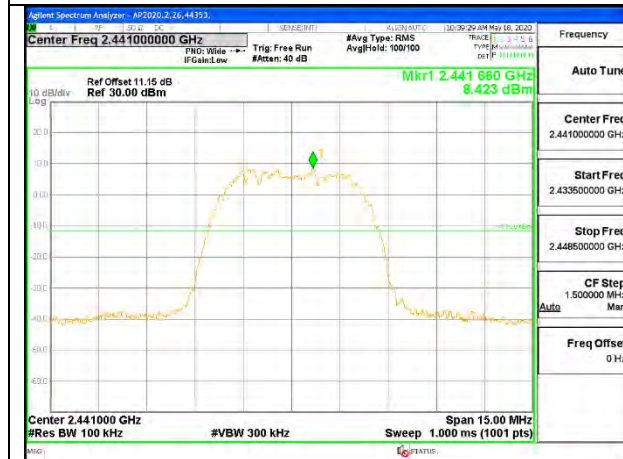

MID CHANNEL REFERENCE LEVEL

OUT-OF-BAND MID CHANNEL

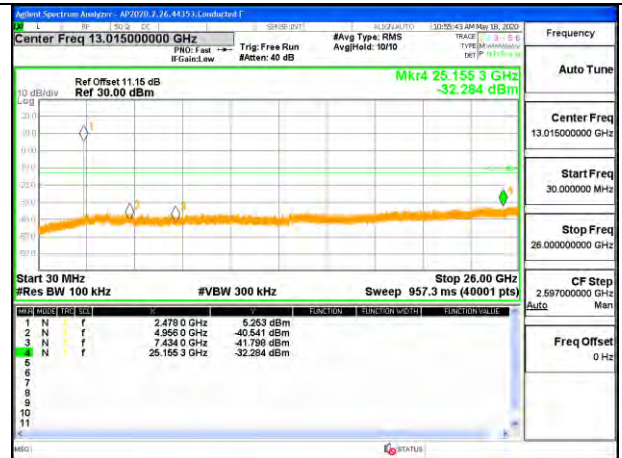

HIGH CHANNEL BANDEDGE

OUT-OF-BAND HIGH CHANNEL

ANT 3



LOW CHANNEL BANDEDGE



OUT-OF-BAND LOW CHANNEL

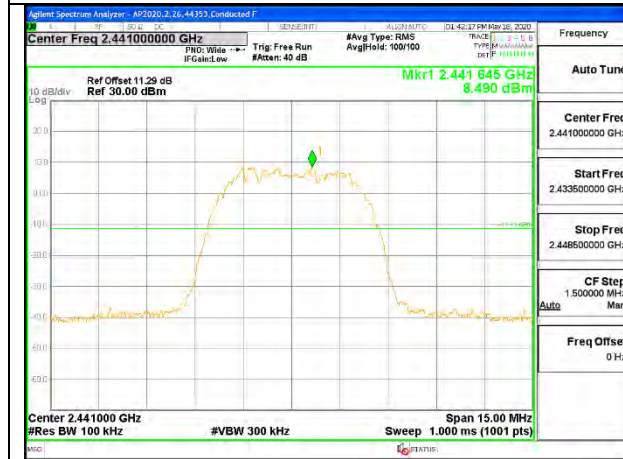

MID CHANNEL REFERENCE LEVEL

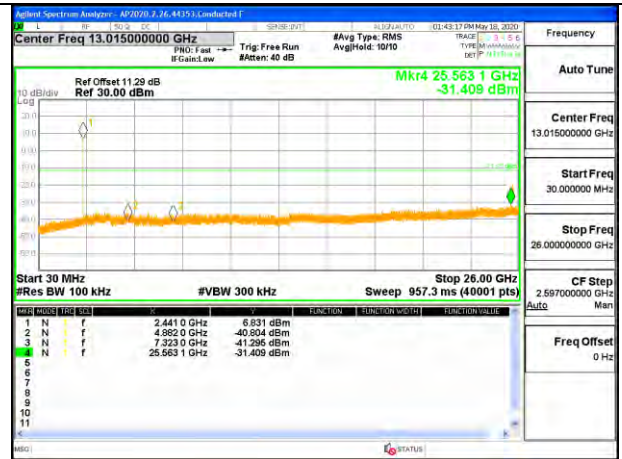

OUT-OF-BAND MID CHANNEL

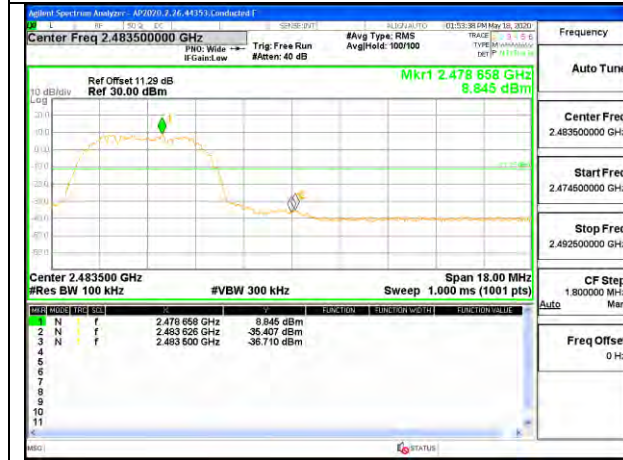

HIGH CHANNEL BANDEDGE

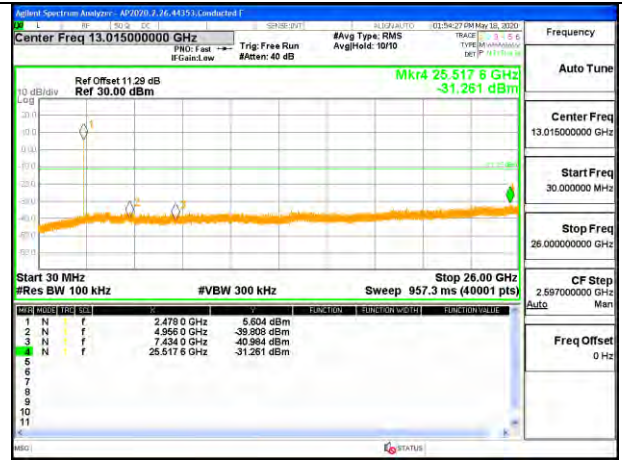

OUT-OF-BAND HIGH CHANNEL

9.7.4. HIGH POWER HDR TXBF (HDR8)

ANT 4



LOW CHANNEL BANDEDGE ANT 4

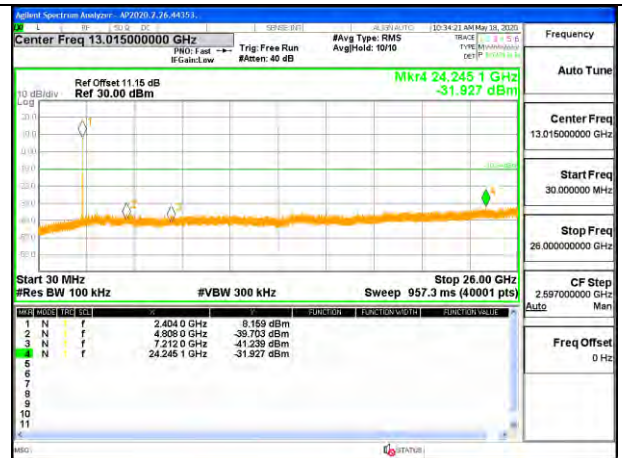

OUT-OF-BAND LOW CHANNEL ANT 4

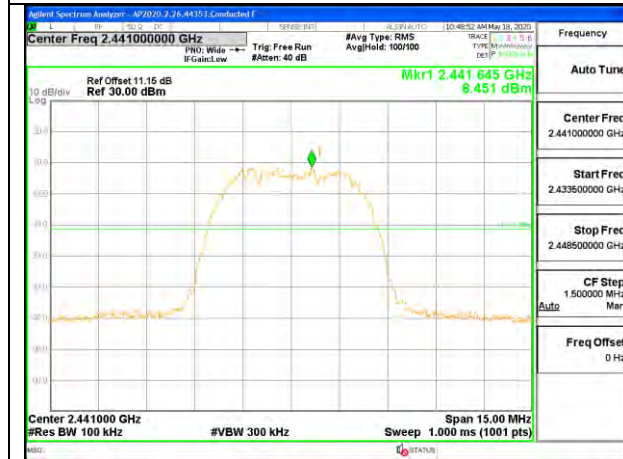

IN-BAND REFERENCE LEVEL ANT 4

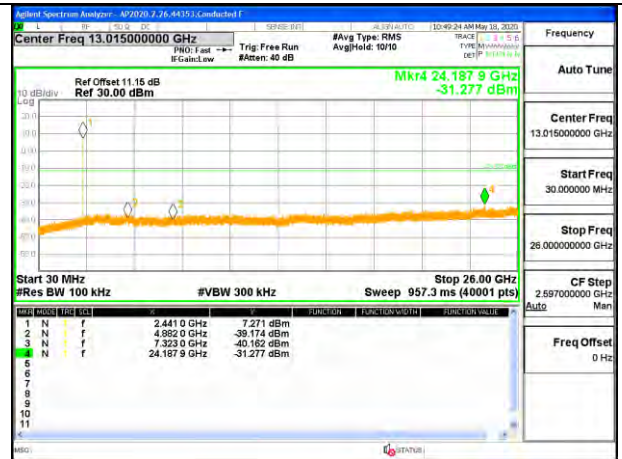

OUT-OF-BAND MID CHANNEL ANT 4



HIGH CHANNEL BANDEDGE ANT 4



OUT-OF-BAND HIGH CHANNEL ANT 4

ANT 3



LOW CHANNEL BANDEDGE ANT 3



OUT-OF-BAND LOW CHANNEL ANT 3

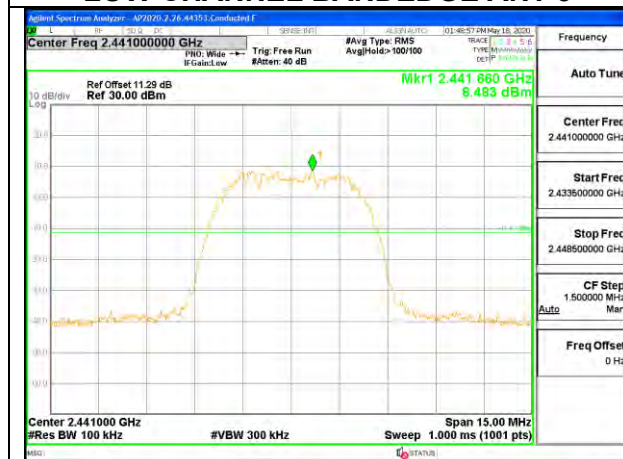

IN-BAND REFERENCE LEVEL ANT 3



OUT-OF-BAND MID CHANNEL ANT 3



HIGH CHANNEL BANDEDGE ANT 3



OUT-OF-BAND HIGH CHANNEL ANT 3

9.7.5. LOW POWER HDR (HDR4)

ANT 4



LOW CHANNEL BANDEDGE

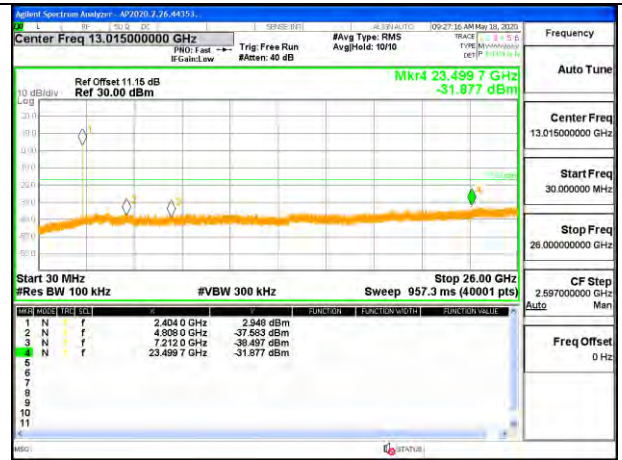

OUT-OF-BAND LOW CHANNEL



IN-BAND REFERENCE LEVEL

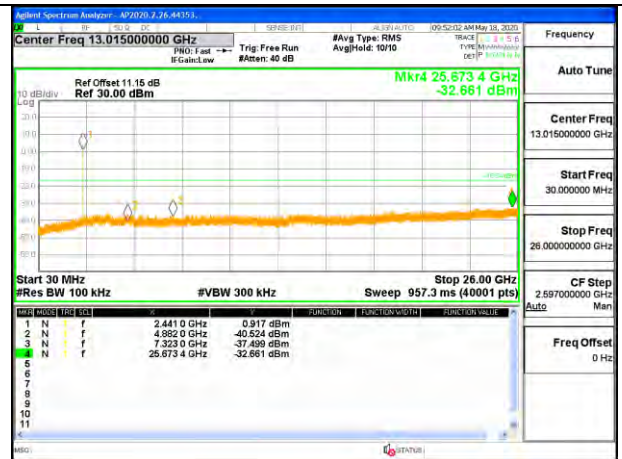

OUT-OF-BAND MID CHANNEL



HIGH CHANNEL BANDEDGE



OUT-OF-BAND HIGH CHANNEL

ANT 3



LOW CHANNEL BANDEDGE



OUT-OF-BAND LOW CHANNEL

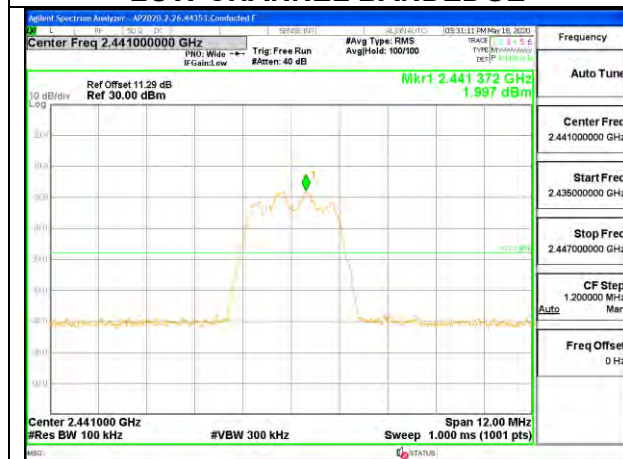

IN-BAND REFERENCE LEVEL



OUT-OF-BAND MID CHANNEL



HIGH CHANNEL BANDEDGE



OUT-OF-BAND HIGH CHANNEL

9.7.6. LOW POWER HDR TXBF (HDR4)

ANT 4

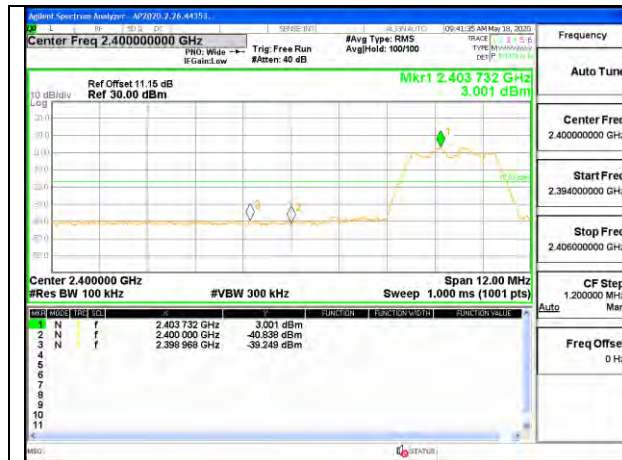

LOW CHANNEL BANDEDGE ANT 4



OUT-OF-BAND LOW CHANNEL ANT 4



IN-BAND REFERENCE LEVEL ANT 4



OUT-OF-BAND MID CHANNEL ANT 4



HIGH CHANNEL BANDEDGE ANT 4



OUT-OF-BAND HIGH CHANNEL ANT 4

ANT 3



LOW CHANNEL BANDEDGE ANT 3



OUT-OF-BAND LOW CHANNEL ANT 3



IN-BAND REFERENCE LEVEL ANT 3



OUT-OF-BAND MID CHANNEL ANT 3



HIGH CHANNEL BANDEDGE ANT 3



OUT-OF-BAND HIGH CHANNEL ANT 3

9.7.7. LOW POWER HDR (HDR8)

ANT 4

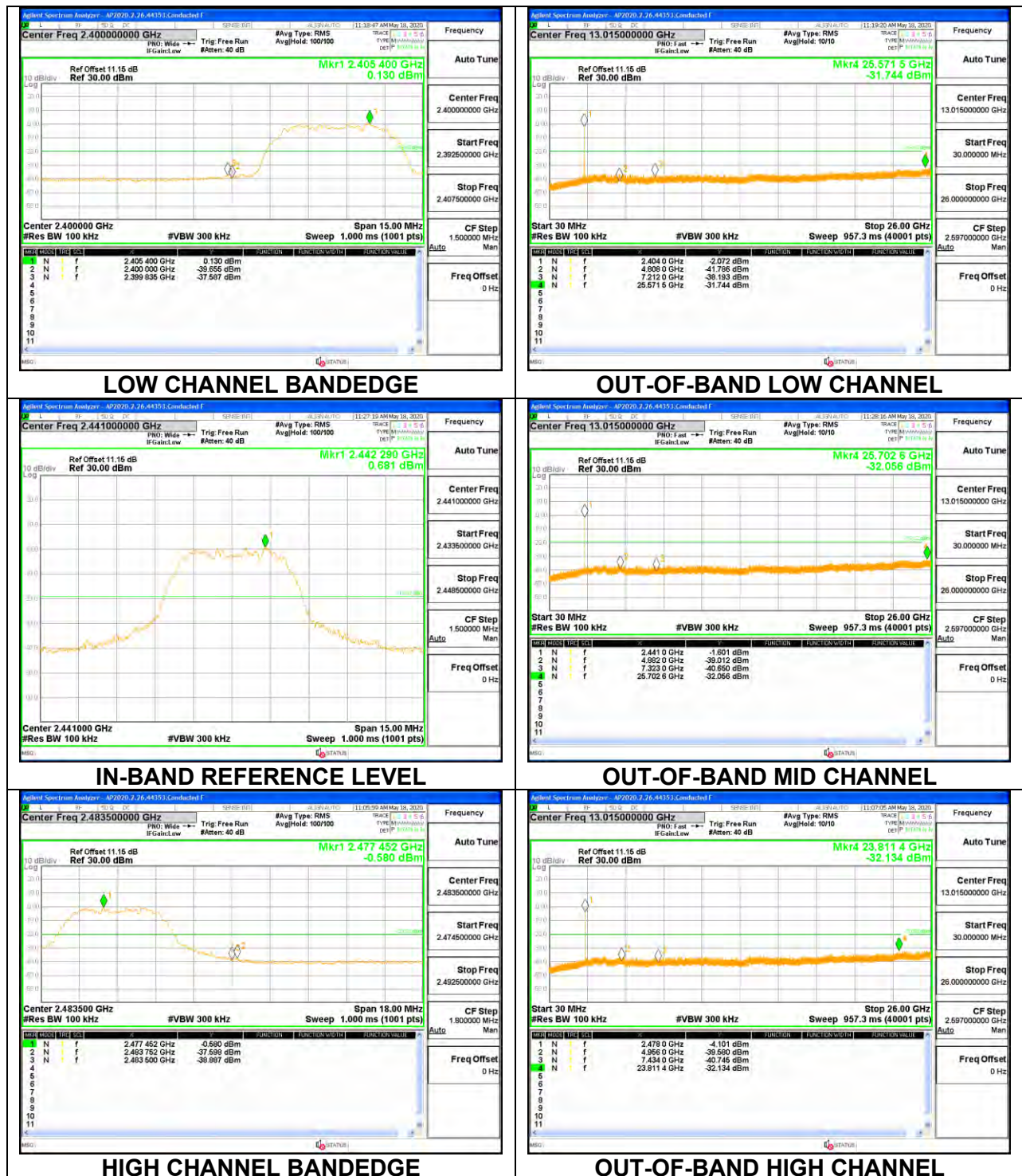

ANT 3



LOW CHANNEL BANDEDGE

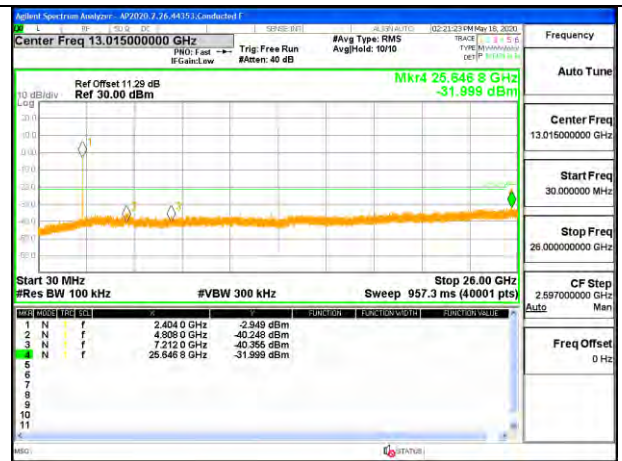

OUT-OF-BAND LOW CHANNEL

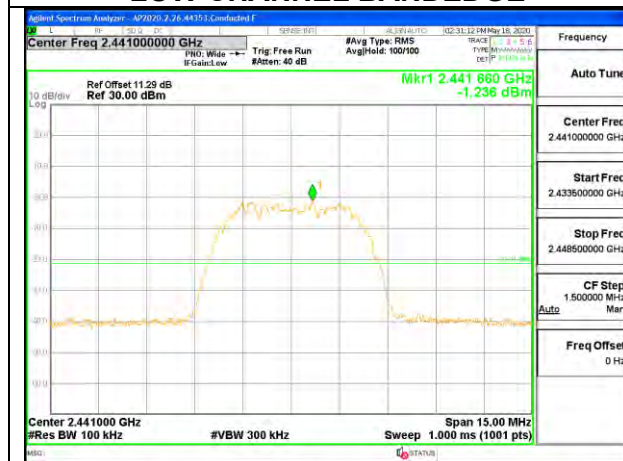

IN-BAND REFERENCE LEVEL



OUT-OF-BAND MID CHANNEL



HIGH CHANNEL BANDEDGE



OUT-OF-BAND HIGH CHANNEL

9.7.8. LOW POWER HDR TXBF (HDR8)

ANT 4



LOW CHANNEL BANDEDGE ANT 4

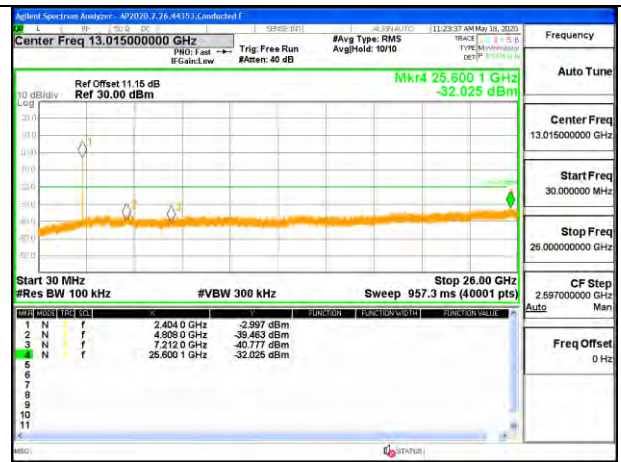

OUT-OF-BAND LOW CHANNEL ANT 4

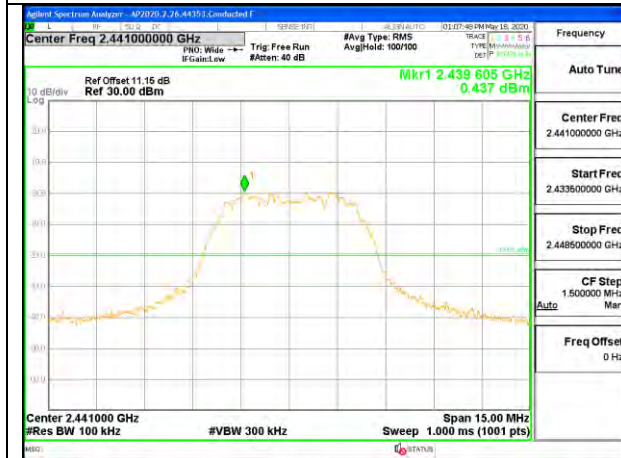

IN-BAND REFERENCE LEVEL ANT 4



OUT-OF-BAND MID CHANNEL ANT 4



HIGH CHANNEL BANDEDGE ANT 4



OUT-OF-BAND HIGH CHANNEL ANT 4

ANT 3



LOW CHANNEL BANDEDGE ANT 3



OUT-OF-BAND LOW CHANNEL ANT 3

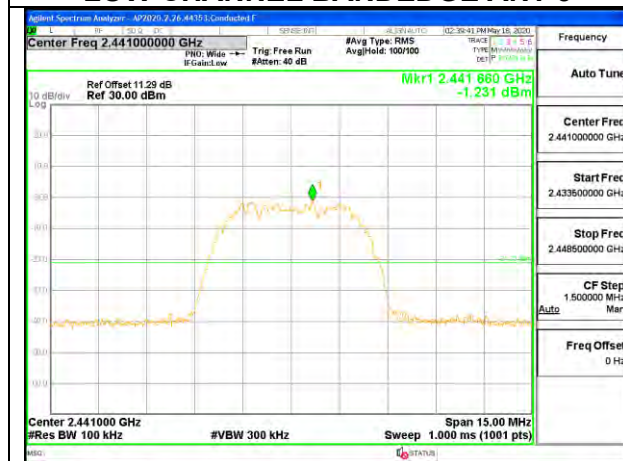

IN-BAND REFERENCE LEVEL ANT 3



OUT-OF-BAND MID CHANNEL ANT 3



HIGH CHANNEL BANDEDGE ANT 3



OUT-OF-BAND HIGH CHANNEL ANT 3