



FCC 47 CFR PART 15 SUBPART C

CERTIFICATION TEST REPORT

FOR

Cellular Phone with Bluetooth and WLAN Radios

MODEL NUMBER: A1586

FCC ID: BCG-E2816A

REPORT NUMBER: 14U17673-E5 Revision C

ISSUE DATE: : AUGUST 03, 2014

Prepared for
APPLE, INC.
1 INFINITE LOOP
CUPERTINO, CA 95014, U.S.A.

Prepared by
UL VERIFICATION SERVICES INC.
47173 BENICIA STREET
FREMONT, CA 94538, U.S.A.
TEL: (510) 771-1000
FAX: (510) 661-0888



NVLAP LAB CODE 200065-0

Revision History

<u>Rev.</u>	<u>Issue Date</u>	<u>Revisions</u>	<u>Revised By</u>
--	7/17/14	Initial Issue	F. de Anda
A	7/23/14	Product Description Updates	H.Lau
B	7/29/14	Updated Sections 1,5, 8, 9 and 10	F. de Anda
C	08/03/14	Address TCB Questions	T. Lee

TABLE OF CONTENTS

1. ATTESTATION OF TEST RESULTS	5
2. TEST METHODOLOGY	6
3. FACILITIES AND ACCREDITATION	6
4. CALIBRATION AND UNCERTAINTY	6
4.1. MEASURING INSTRUMENT CALIBRATION	6
4.2. SAMPLE CALCULATION	6
4.3. MEASUREMENT UNCERTAINTY	7
5. EQUIPMENT UNDER TEST	8
5.1. DESCRIPTION OF EUT	8
5.2. MAXIMUM OUTPUT POWER	8
5.3. DESCRIPTION OF AVAILABLE ANTENNAS	8
5.4. SOFTWARE AND FIRMWARE	8
5.5. WORST-CASE CONFIGURATION AND MODE	9
5.6. DESCRIPTION OF TEST SETUP	10
6. TEST AND MEASUREMENT EQUIPMENT	14
7. MEASUREMENT METHODS	15
8. ON TIME, DUTY CYCLE AND MEASUREMENT METHODS	16
8.1. ON TIME AND DUTY CYCLE RESULTS	16
8.2. DUTY CYCLE PLOTS	17
9. ANTENNA PORT TEST RESULTS	19
9.1. 802.11b MODE IN THE 2.4 GHz BAND	19
9.1.1. 6 dB BANDWIDTH	19
9.1.2. 99% BANDWIDTH	23
9.1.3. AVERAGE POWER	27
9.1.4. OUTPUT POWER	28
9.1.5. PSD	30
9.1.6. OUT-OF-BAND EMISSIONS	35
9.2. 802.11g MODE IN THE 2.4 GHz BAND	42
9.2.1. 6 dB BANDWIDTH	42
9.2.2. 99% BANDWIDTH	46
9.2.3. AVERAGE POWER	50
9.2.1. OUTPUT POWER	51
9.2.2. PSD	53
9.2.3. OUT-OF-BAND EMISSIONS	58
9.3. 802.11n HT20 1Tx SISO MODE IN THE 2.4 GHz BAND	64
9.3.1. 6 dB BANDWIDTH	64
9.3.2. 99% BANDWIDTH	68

9.3.3.	AVERAGE POWER	72
9.3.4.	OUTPUT POWER.....	73
9.3.5.	PSD	75
9.3.6.	OUT-OF-BAND EMISSIONS	80
10.	RADIATED TEST RESULTS	86
10.1.	LIMITS AND PROCEDURE.....	86
10.2.	TX RADIATED ABOVE 1 GHz.....	87
10.2.1.	802.11b 1Tx SISO MODE IN THE 2.4 GHz BAND	87
10.2.2.	802.11g 1Tx SISO MODE IN THE 2.4 GHz BAND	109
10.2.3.	802.11n HT20 1Tx SISO MODE IN THE 2.4 GHz BAND.....	131
10.3.	WORST-CASE BELOW 1 GHz	153
10.4.	WORST-CASE ABOVE 18 to 26GHz	155
11.	AC POWER LINE CONDUCTED EMISSIONS.....	157
12.	SETUP PHOTOS	161

1. ATTESTATION OF TEST RESULTS

COMPANY NAME: APPLE
1 INFINITE LOOP
CUPERTINO, CA 95014, U.S.A.

EUT DESCRIPTION: Cellular Phone with Bluetooth and WLAN Radios

MODEL: A1586

SERIAL NUMBER: C39MF01KFY6W

DATE TESTED: APRIL 16 – JULY 08, 2014

APPLICABLE STANDARDS	
STANDARD	TEST RESULTS
CFR 47 Part 15 Subpart C	Pass

UL Verification Services Inc. tested the above equipment in accordance with the requirements set forth in the above standards. All indications of Pass/Fail in this report are opinions expressed by UL Verification Services Inc. based on interpretations and/or observations of test results. Measurement Uncertainties were not taken into account and are published for informational purposes only. The test results show that the equipment tested is capable of demonstrating compliance with the requirements as documented in this report.

Note: The results documented in this report apply only to the tested sample, under the conditions and modes of operation as described herein. This document may not be altered or revised in any way unless done so by UL Verification Services Inc. and all revisions are duly noted in the revisions section. Any alteration of this document not carried out by UL Verification Services Inc. will constitute fraud and shall nullify the document. This report must not be used by the client to claim product certification, approval, or endorsement by NVLAP, NIST, any agency of the Federal Government, or any agency of any government.

Approved & Released For
UL Verification Services Inc. By:



FRANCISCO DE ANDA
PROJECT LEAD
UL VERIFICATION SERVICES INC.

Tested By:



JOE VANG
EMC TECHNICIAN
UL VERIFICATION SERVICES INC.

2. TEST METHODOLOGY

The tests documented in this report were performed in accordance with FCC CFR 47 Part 2, FCC CFR 47 Part 15, KDB558074 and ANSI C63.10-2009.

3. FACILITIES AND ACCREDITATION

The test sites and measurement facilities used to collect data are located at 47173 and 47266 Benicia Street, Fremont, California, USA. Line conducted emissions are measured only at the 47173 address. The following table identifies which facilities were utilized for radiated emission measurements documented in this report. Specific facilities are also identified in the test results sections.

47173 Benicia Street	47266 Benicia Street
<input type="checkbox"/> Chamber A	<input checked="" type="checkbox"/> Chamber D
<input type="checkbox"/> Chamber B	<input checked="" type="checkbox"/> Chamber E
<input type="checkbox"/> Chamber C	<input checked="" type="checkbox"/> Chamber F
	<input type="checkbox"/> Chamber G
	<input checked="" type="checkbox"/> Chamber H

UL Verification Services Inc. is accredited by NVLAP, Laboratory Code 200065-0. The full scope of accreditation can be viewed at <http://ts.nist.gov/standards/scopes/2000650.htm>.

4. CALIBRATION AND UNCERTAINTY

4.1. MEASURING INSTRUMENT CALIBRATION

The measuring equipment utilized to perform the tests documented in this report has been calibrated in accordance with the manufacturer's recommendations, and is traceable to recognized national standards.

4.2. SAMPLE CALCULATION

Where relevant, the following sample calculation is provided:

$$\begin{aligned} \text{Field Strength (dBuV/m)} &= \text{Measured Voltage (dBuV)} + \text{Antenna Factor (dB/m)} + \text{Cable Loss} \\ & \text{(dB)} - \text{Preamp Gain (dB)} \\ 36.5 \text{ dBuV} + 18.7 \text{ dB/m} + 0.6 \text{ dB} - 26.9 \text{ dB} &= 28.9 \text{ dBuV/m} \end{aligned}$$

4.3. MEASUREMENT UNCERTAINTY

Where relevant, the following measurement uncertainty levels have been estimated for tests performed on the apparatus:

PARAMETER	UNCERTAINTY
Conducted Disturbance, 0.15 to 30 MHz	± 3.52 dB
Radiated Disturbance, 30 to 1000 MHz	± 4.94 dB

Uncertainty figures are valid to a confidence level of 95%.

5. EQUIPMENT UNDER TEST

5.1. DESCRIPTION OF EUT

Model A1586 is a mobile phone with multimedia functions (music, application support, and video), Cellular GSM/GPRS/EGPRS/CDMA2000/EVDO Rev.A/ EVDO Rev.B/WCDMA/HSPA+/DC-HSDPA/LTE FDD & Carrier Aggregation/TDD/TD-SCDMA radio, IEEE 802.11a/b/g/n/ac radio, Bluetooth radio and NFC. The rechargeable battery is not user accessible.

5.2. MAXIMUM OUTPUT POWER

The transmitter has a maximum conducted output power as follows:

Frequency Range (MHz)	Mode	Output Power (dBm)	Output Power (mW)
2412 - 2472	802.11b	21.7	147.91
2412 - 2472	802.11g	24.99	315.50
2412 - 2472	802.11n HT20	25.09	322.85

5.3. DESCRIPTION OF AVAILABLE ANTENNAS

The radio utilizes a PiFA antenna, with a maximum gain of -0.38 dBi.

5.4. SOFTWARE AND FIRMWARE

The firmware installed in the EUT during testing was 7.16.121

The test utility software used during testing was wl 7.16 RC121.0.

5.5. WORST-CASE CONFIGURATION AND MODE

Radiated emission and power line conducted emission were performed with the EUT set to transmit at the channel with highest output power as worst-case scenario.

The fundamental of the EUT was investigated in three orthogonal orientations X (Flatbed), Y (Landscape), Z (Portrait), it was determined that X orientation was worst-case orientation; therefore, all final radiated testing was performed with the EUT in X (Flatbed) orientation.

Worst-case data rates as provided by the client were:

802.11b mode: 1 Mbps
802.11g mode: 6 Mbps
802.11n HT20mode: MCS0

Radiated emissions for EUT with antenna was performed and passed; therefore, antenna port spurious was not performed.

There are three vendors of the WiFi/Bluetooth radio modules: variant 1, variant 2 and variant 3 and they have the same mechanical outline, same on board antenna, matching circuit, antenna structure and same specification. Baseline testing was performed on all three variants to determine the worst case on all conducted power and radiated emissions.

5.6. DESCRIPTION OF TEST SETUP

SUPPORT EQUIPMENT

Support Equipment List				
Description	Manufacturer	Model	Serial Number	FCC ID
AC/DC adapter	Apple	A1401	60812	NA
Earphone	Apple	NA	NA	NA
Laptop	Apple	A1278	C02HJ0A7DTY4	NA

I/O CABLES (CONDUCTED TEST)

I/O Cable List						
Cable No	Port	# of identical ports	Connector Type	Cable Type	Cable Length (m)	Remarks
1	Antenna	1	SMA	Un-Shielded	0.1	to spectrum Analyzer
2	USB	1	USB	Shielded	1m	To EUT

I/O CABLES (RADIATED ABOVE 1 GHZ)

I/O Cable List						
Cable No	Port	# of identical ports	Connector Type	Cable Type	Cable Length (m)	Remarks
None used						

I/O CABLES (BELOW 1GHZ & AC LINE CONDUCTED TESTS)

I/O Cable List						
Cable No	Port	# of identical ports	Connector Type	Cable Type	Cable Length (m)	Remarks
1	AC	1	US115	Un-Shielded	80cm	NA
2	DC	1	USB	Un-Shielded	1m	NA
3	Audio	1	Jack	Un-Shielded	0.5m	NA

TEST SETUP- CONDUCTED PORT

The EUT was tested connected to a host Laptop via USB cable adapter and spectrum analyzer to antenna port. Test software exercised the EUT.

SETUP DIAGRAM

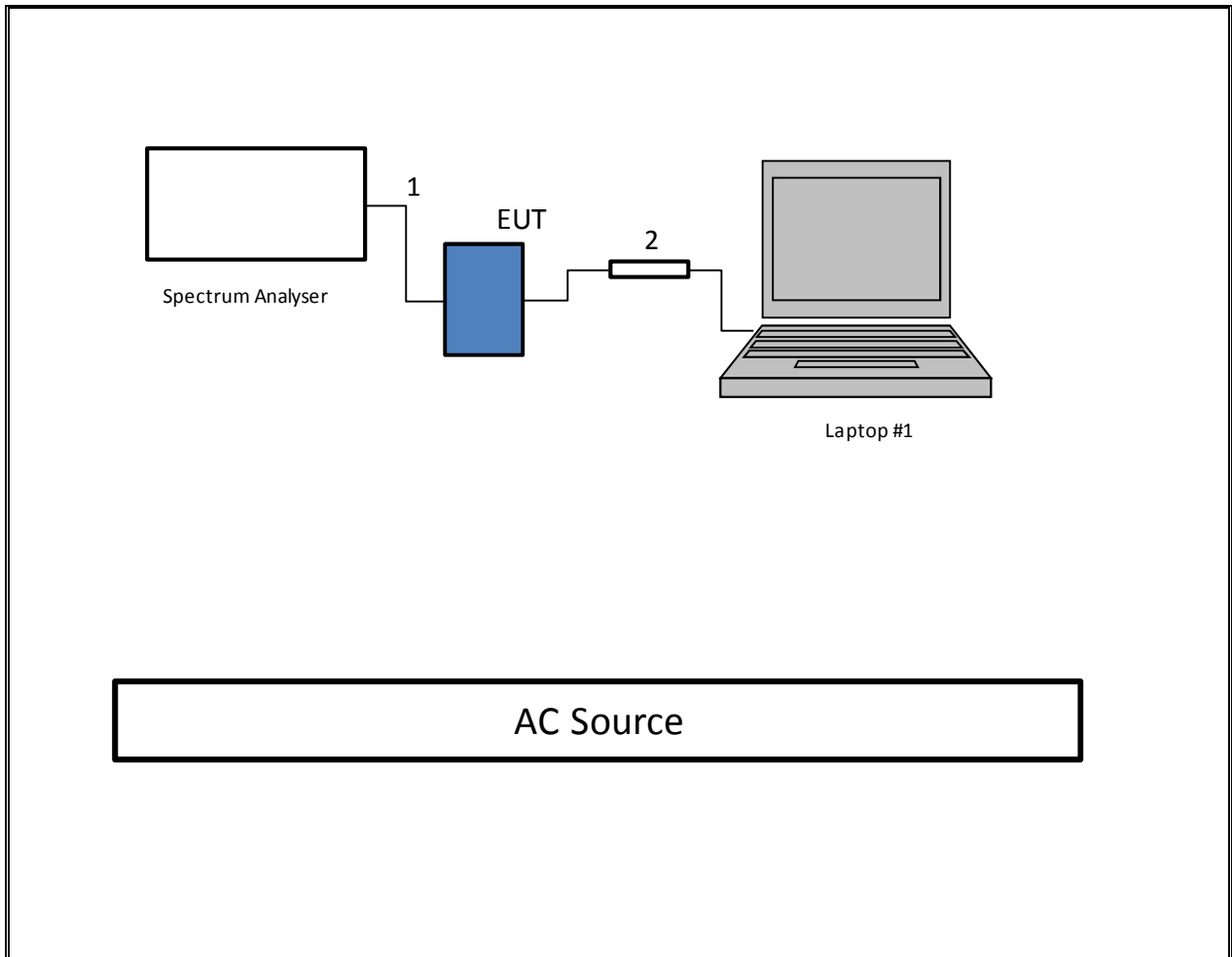

TEST SETUP- RADIATED-ABOVE 1 GHZ

The EUT was tested battery powered. Test software exercised the EUT.

SETUP DIAGRAM

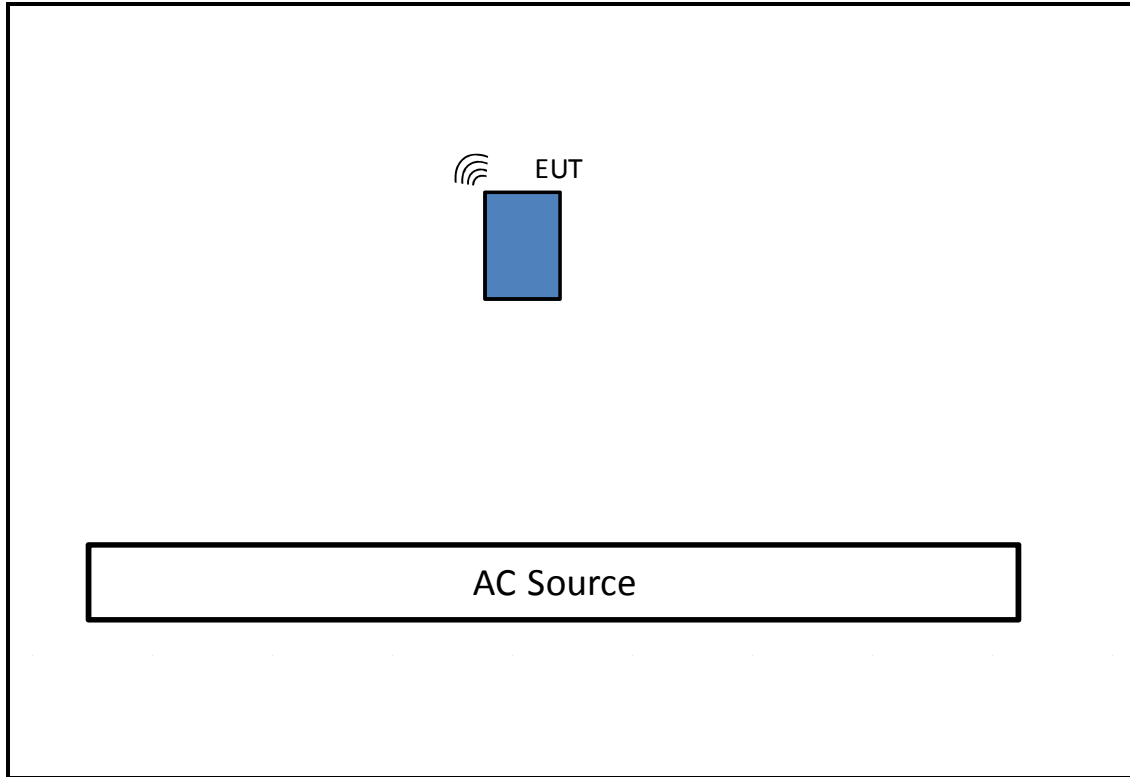

TEST SETUP- BELOW 1GHZ & AC LINE CONDUCTED TESTS

The EUT was tested with earphones connected and powered by AC adapter. Test software exercised the EUT.

SETUP DIAGRAM

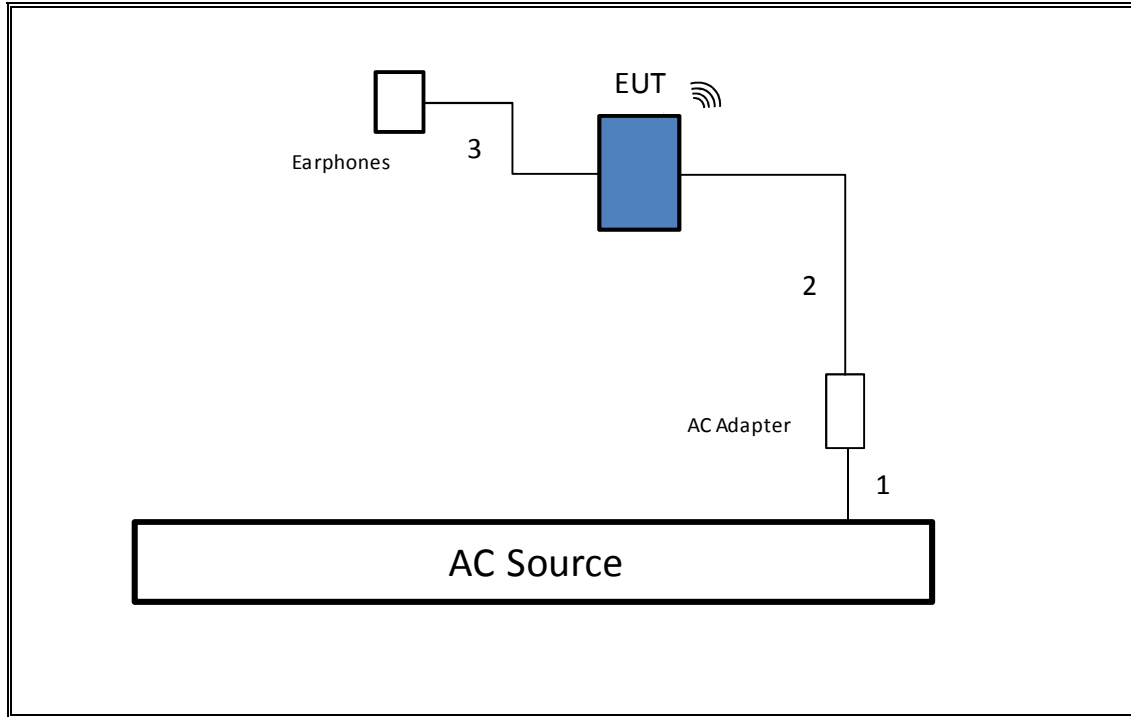

6. TEST AND MEASUREMENT EQUIPMENT

The following test and measurement equipment was utilized for the tests documented in this report

TEST EQUIPMENT LIST				
Description	Manufacturer	Model	Asset	Cal Due
Antenna, Horn, 18 GHz	ETS Lindgren	3117	F00131	2/18/2015
Antenna, Horn, 26.5 GHz	ARA	MWH-1826/B	C00589	11/28/2014
Peak / Average Power Sensor	Agilent / HP	N1911A	F00153	3/6/2015
Wideband Power Sensor	Agilent	N1921A	F00361	10/2/2014
Peak Power Meter	Agilent / HP	E9323A	F00025	4/3/2015
Spectrum Analyzer, 44 GHz	Agilent / HP	N9030A	F00129	2/22/2015
Antenna, Bilog, 2 GHz	Sunol Sciences	JB1	F00168	3/28/2015
Preamplifier, 1300 MHz	Sonoma	310	F00008	5/27/2015
Preamplifier, 26.5 GHz	Agilent / HP	8449B	F00165	3/25/2015
EMI Test Receiver, 9 kHz-7 GHz	R & S	ESCI 7	F00092	9/5/2014
LISN, 30 MHz	FCC	LISN-50/250-25-2	C00626	1/14/2015

7. MEASUREMENT METHODS

6 dB BW: KDB 558074 D01 v03r02, Section 8.1.

Output Power: KDB 558074 D01 v03r02, Section 9.1.2.

Power Spectral Density: KDB 558074 D01 v03r02, Section 10.2.

Out-of-band emissions in non-restricted bands: KDB 558074 D01 v03r02, Section 11.0.

Out-of-band emissions in restricted bands: KDB 558074 D01 v03r02, Section 12.0.

Band-edge: KDB 558074 D01 v03r02, Section 13.3.1.

8. ON TIME, DUTY CYCLE AND MEASUREMENT METHODS

LIMITS

None; for reporting purposes only.

PROCEDURE

KDB 558074 Zero-Span Spectrum Analyzer Method.

8.1. ON TIME AND DUTY CYCLE RESULTS

Mode	ON Time B (msec)	Period (msec)	Duty Cycle x (linear)	Duty Cycle (%)	Duty Cycle Correction Factor (dB)	1/B Minimum VBW (kHz)
2.4GHz Band						
802.11b 1TX	12.400	12.460	0.995	99.52%	0.00	0.010
802.11g 1TX	2.065	2.120	0.974	97.41%	0.11	0.484
802.11n HT20 1TX	1.920	1.941	0.989	98.92%	0.00	0.010

8.2. DUTY CYCLE PLOTS

2.4 GHz BAND

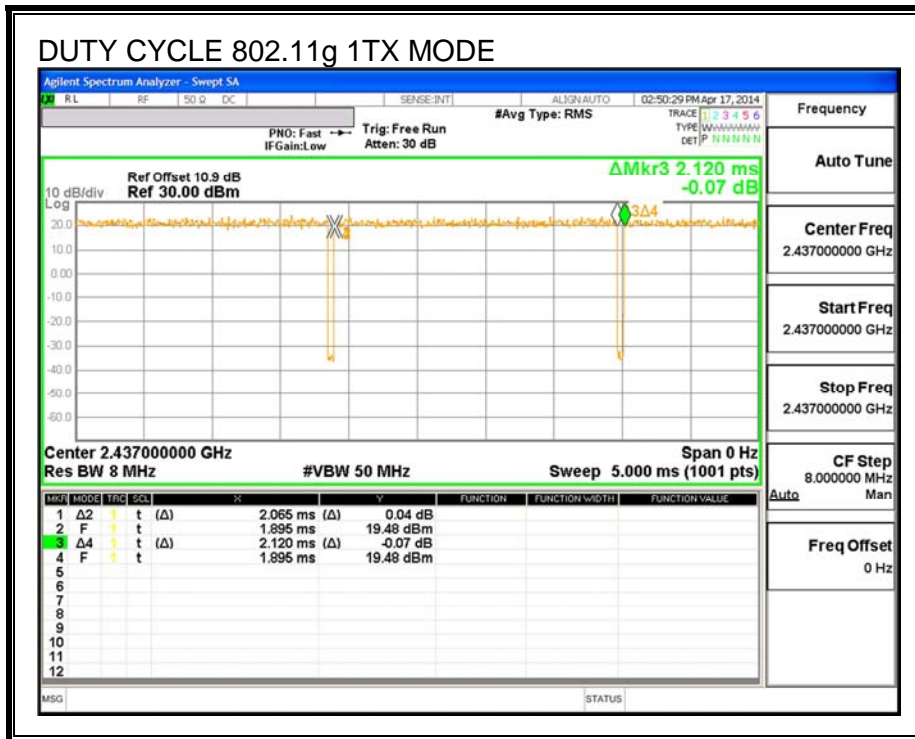
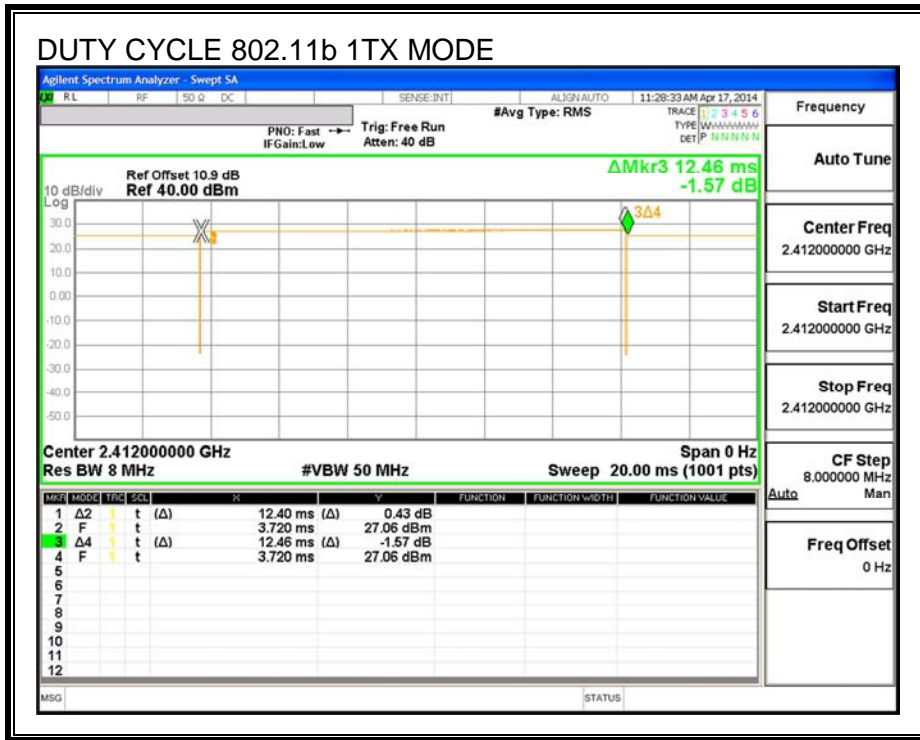

9. ANTENNA PORT TEST RESULTS

9.1. 802.11b MODE IN THE 2.4 GHz BAND

9.1.1. 6 dB BANDWIDTH

LIMITS

FCC §15.247 (a) (2)

The minimum 6 dB bandwidth shall be at least 500 kHz.

RESULTS

Channel	Frequency (MHz)	6 dB Bandwidth (MHz)	Minimum Limit (MHz)
Low	2412	9.555	0.5
Mid	2437	8.567	0.5
High	2462	9.585	0.5
High	2467	9.058	0.5
High	2472	8.580	0.5

6 dB BANDWIDTH

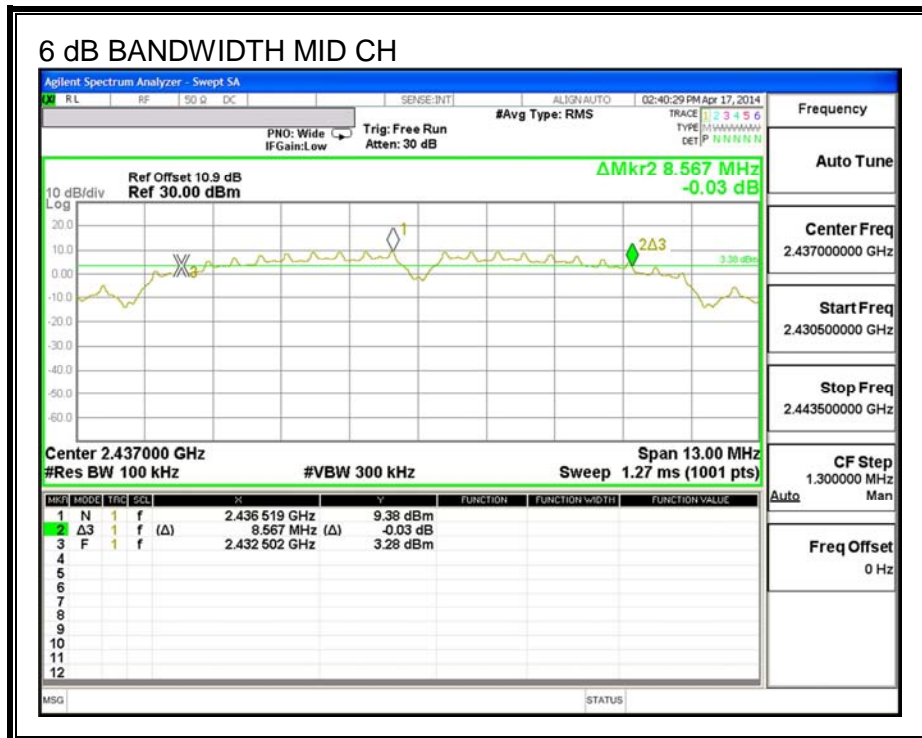
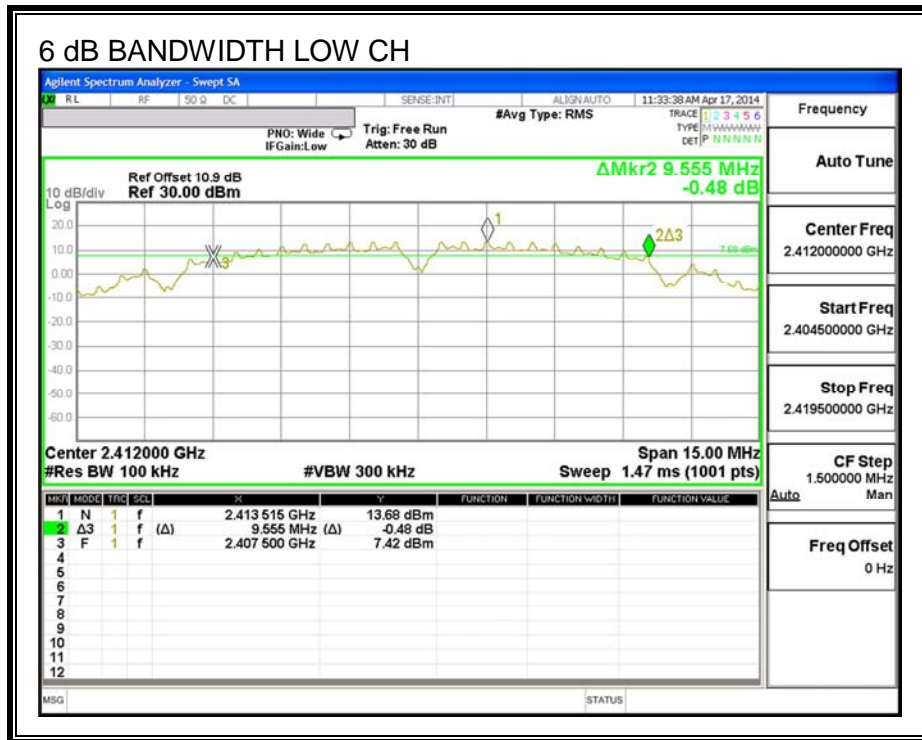

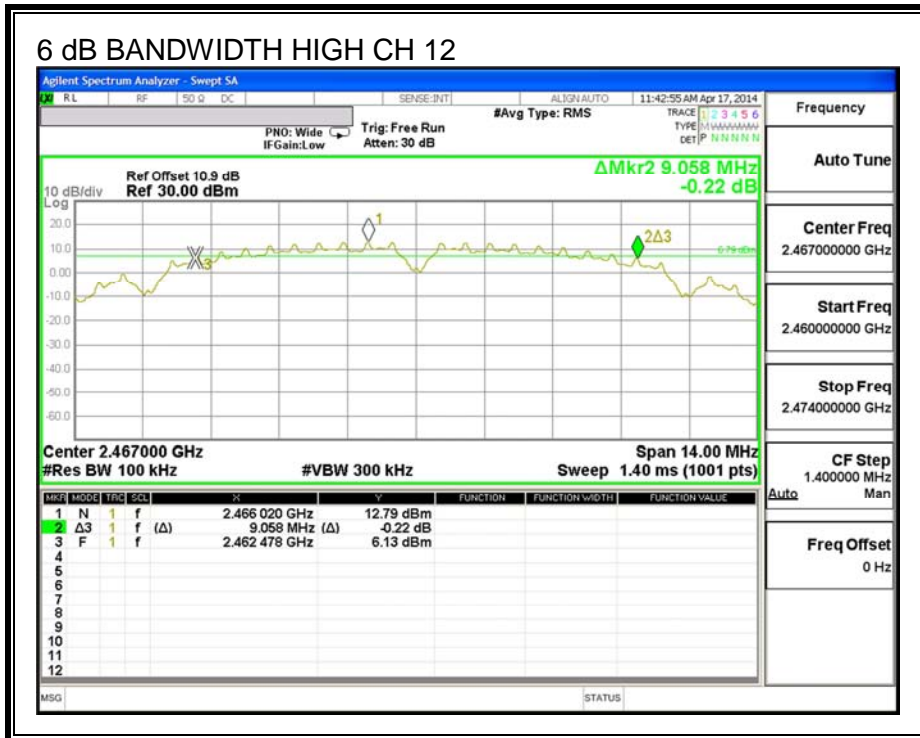
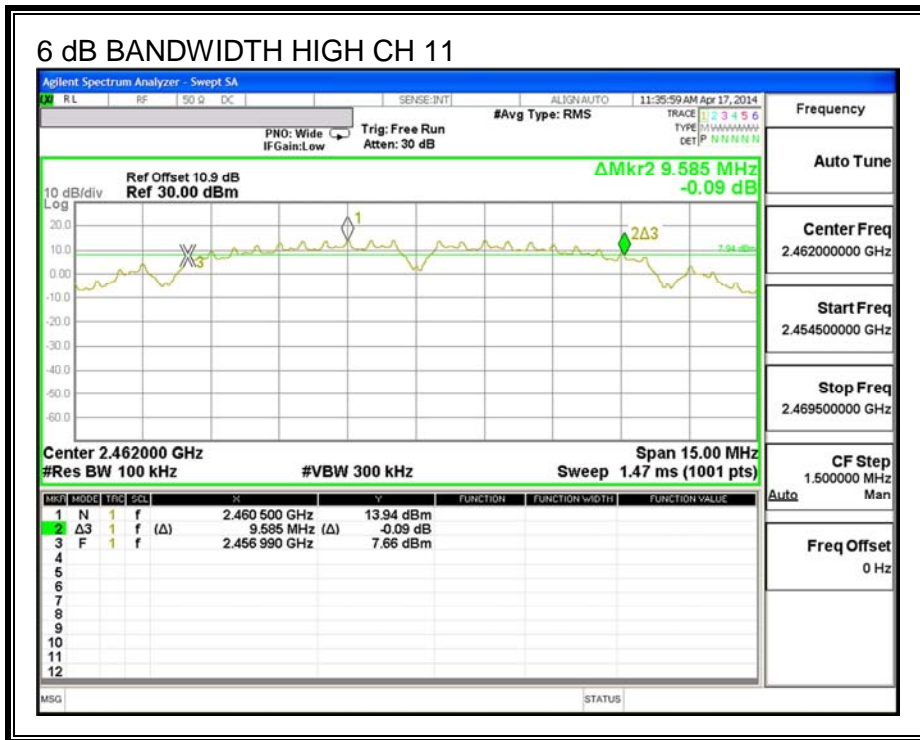

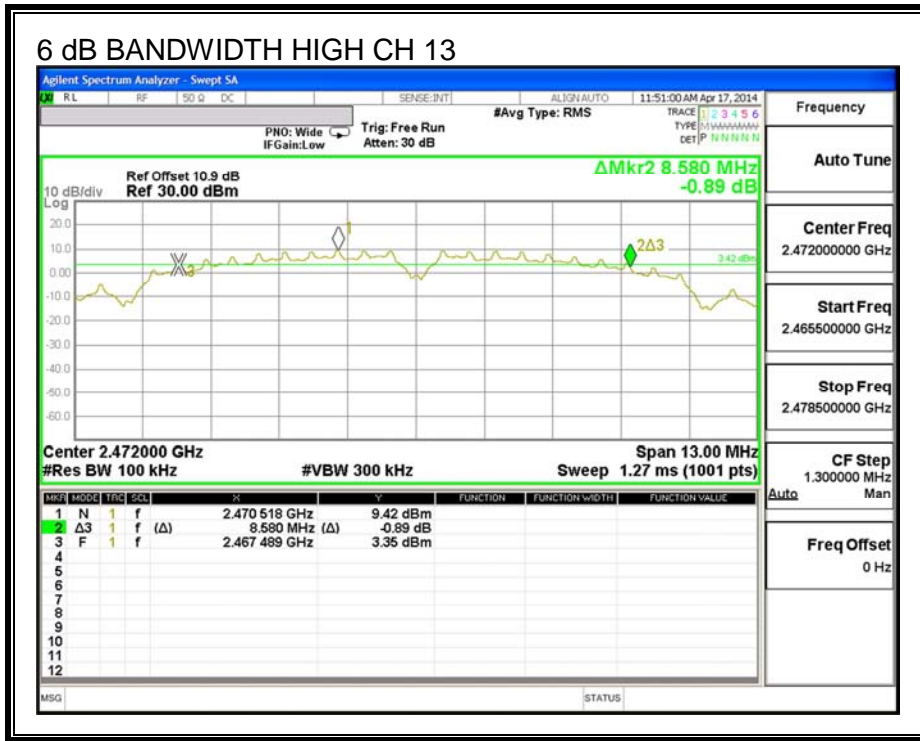

9.1.2. 99% BANDWIDTH

LIMITS

None; for reporting purposes only.

RESULTS

Channel	Frequency (MHz)	99% Bandwidth (MHz)
Low	2412	13.610
Mid	2437	10.396
High	2462	12.828
High	2467	11.958
High	2472	10.189

99% BANDWIDTH

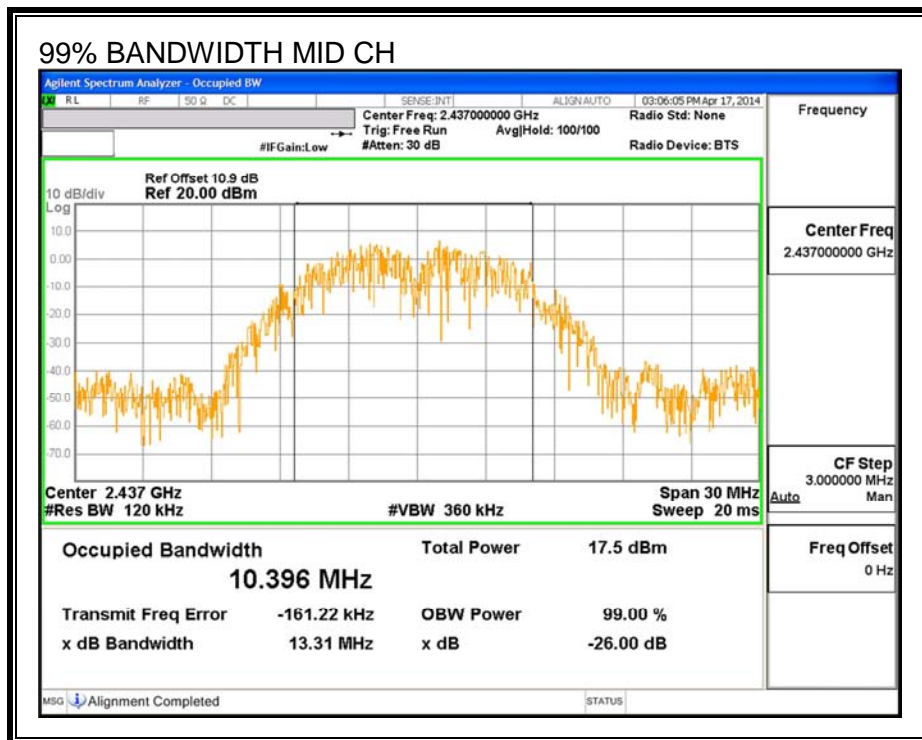
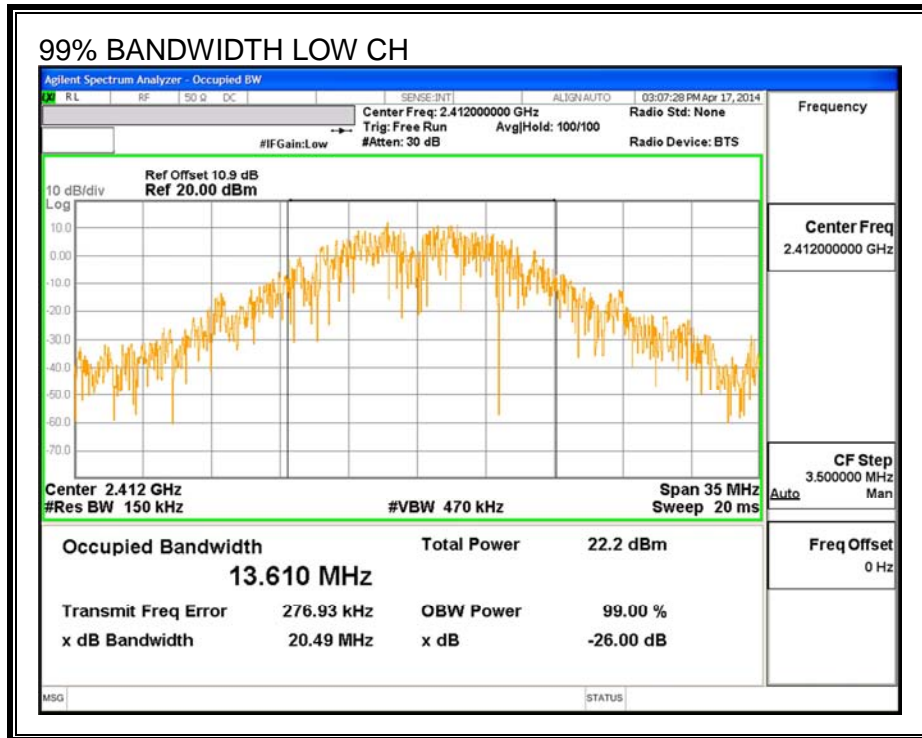

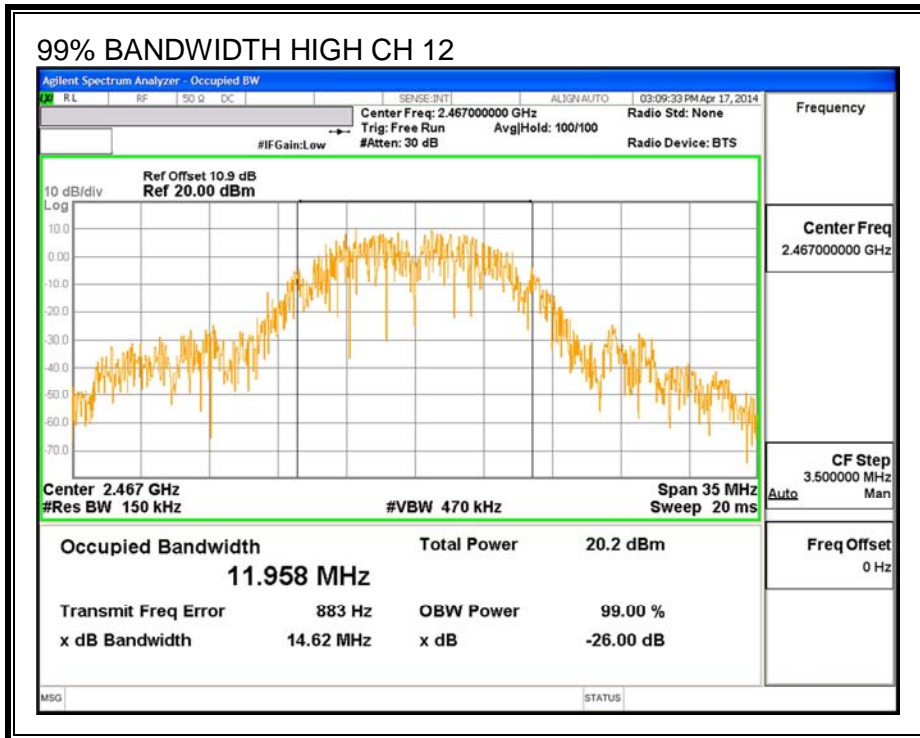
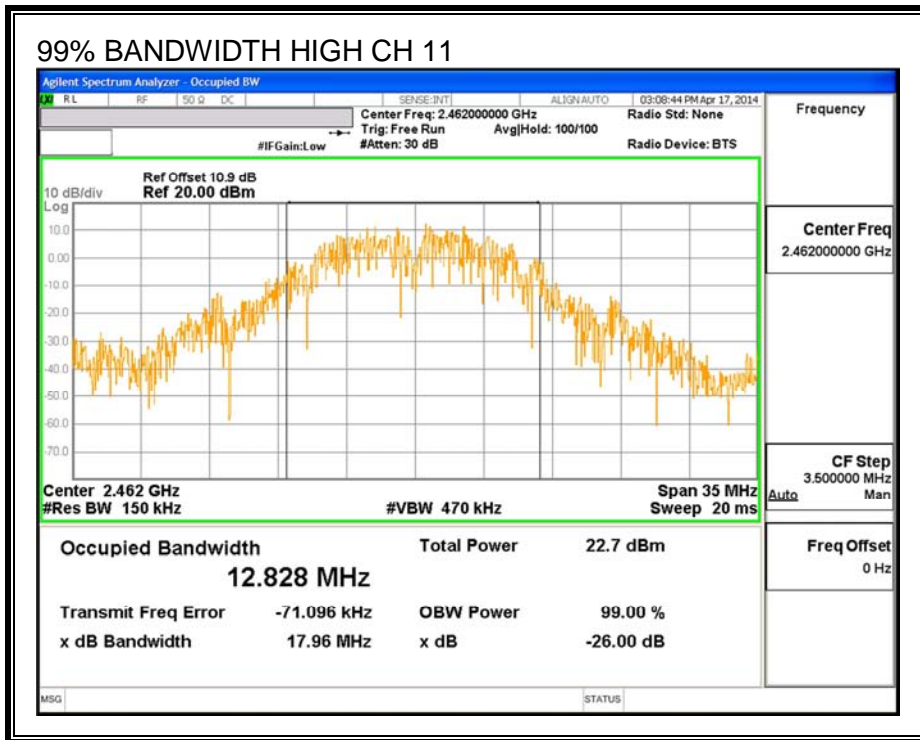

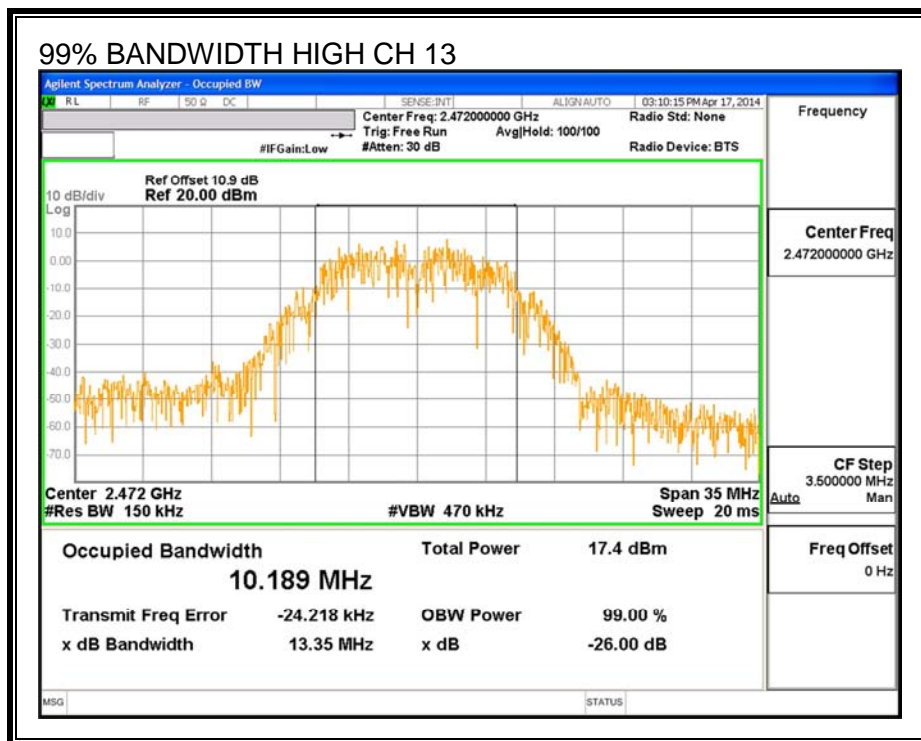

9.1.3. AVERAGE POWER

LIMITS

None; for reporting purposes only.

RESULTS

Channel	Frequency (MHz)	Power (dBm)
1	2412	17.99
2	2417	18.07
3	2422	17.95
6	2437	17.99
11	2462	17.96
12	2467	16.48
13	2472	15.48

9.1.4. OUTPUT POWER

LIMITS

FCC §15.247

For systems using digital modulation in the 2400–2483.5 MHz band: 1 Watt, based on the use of antennas with directional gains that do not exceed 6dBi. If transmitting antennas of directional gain greater than 6dBi are used, the conducted output power from the intentional radiator shall be reduced by the amount in dB that the directional gain of the antenna exceeds 6dBi.

DIRECTIONAL ANTENNA GAIN

There is only one transmitter output therefore the directional gain is equal to the antenna gain.

RESULTS

Limits

Channel	Frequency (MHz)	Directional Gain (dBi)	FCC Power Limit (dBm)
1	2412	-0.38	30.00
2	2417	-0.38	30.00
3	2422	-0.38	30.00
6	2437	-0.38	30.00
11	2462	-0.38	30.00
12	2467	-0.38	30.00
13	2472	-0.38	30.00

Results

Channel	Frequency (MHz)	Meas Power (dBm)	Total Corr'd Power (dBm)	Power Limit (dBm)	Margin (dB)
1	2412	19.06	19.06	30.00	-10.94
2	2417	21.54	21.54	30.00	-8.46
3	2422	21.54	21.54	30.00	-8.46
6	2437	21.70	21.70	30.00	-8.30
11	2462	21.48	21.48	30.00	-8.52
12	2467	19.74	19.74	30.00	-10.26
13	2472	19.39	19.39	30.00	-10.61

9.1.5. PSD

LIMITS

FCC §15.247 (e)

For digitally modulated systems, the power spectral density conducted from the intentional radiator to the antenna shall not be greater than 8 dBm in any 3 kHz band during any time interval of continuous transmission. This power spectral density shall be determined in accordance with the provisions of paragraph (b) of this section. The same method of determining the conducted output power shall be used to determine the power spectral density.

RESULTS

PSD Results

Channel	Frequency (MHz)	Meas (dBm)	Limit (dBm)	Margin (dB)
1	2412	-2.170	8.0	-10.2
2	2417	-3.360	8.0	-11.4
3	2422	-4.400	8.0	-12.4
6	2437	-4.229	8.0	-12.2
11	2462	-3.992	8.0	-12.0
12	2467	-5.592	8.0	-13.6
13	2472	-6.031	8.0	-14.0

PSD

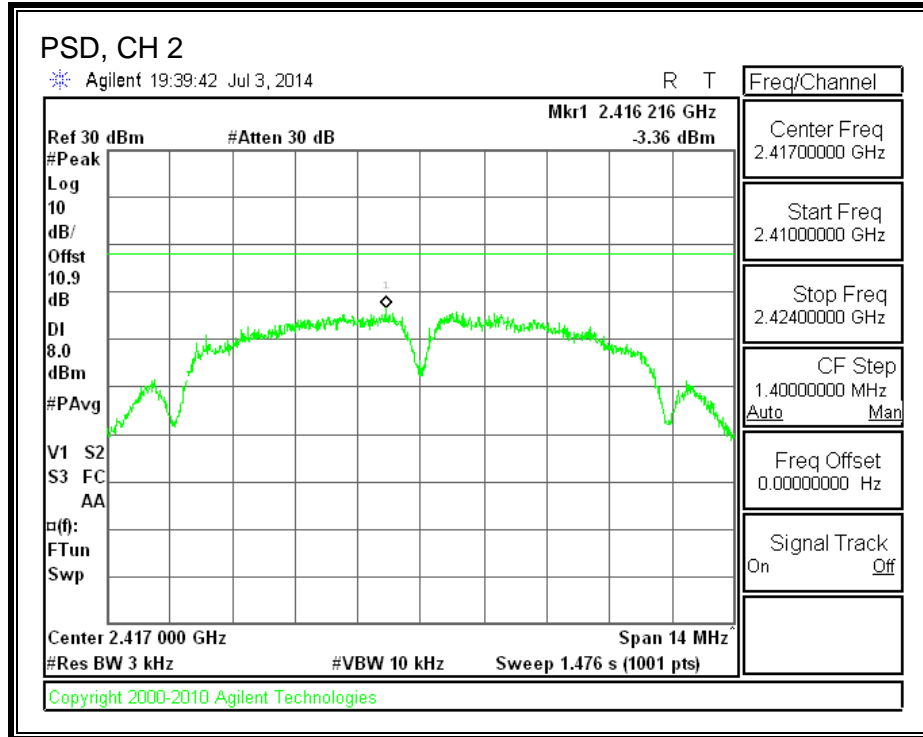
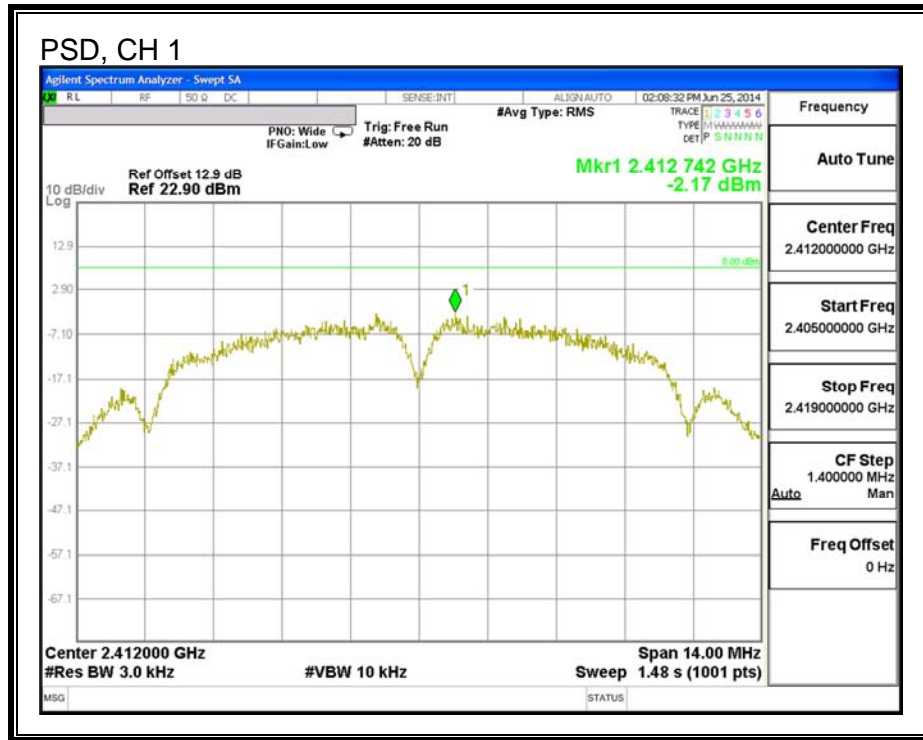

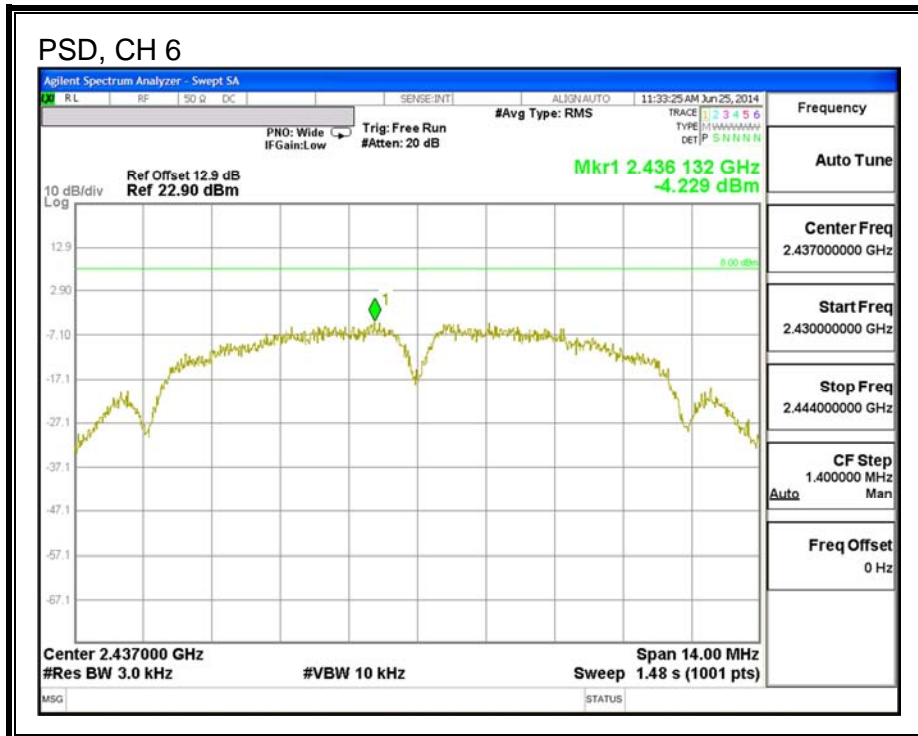
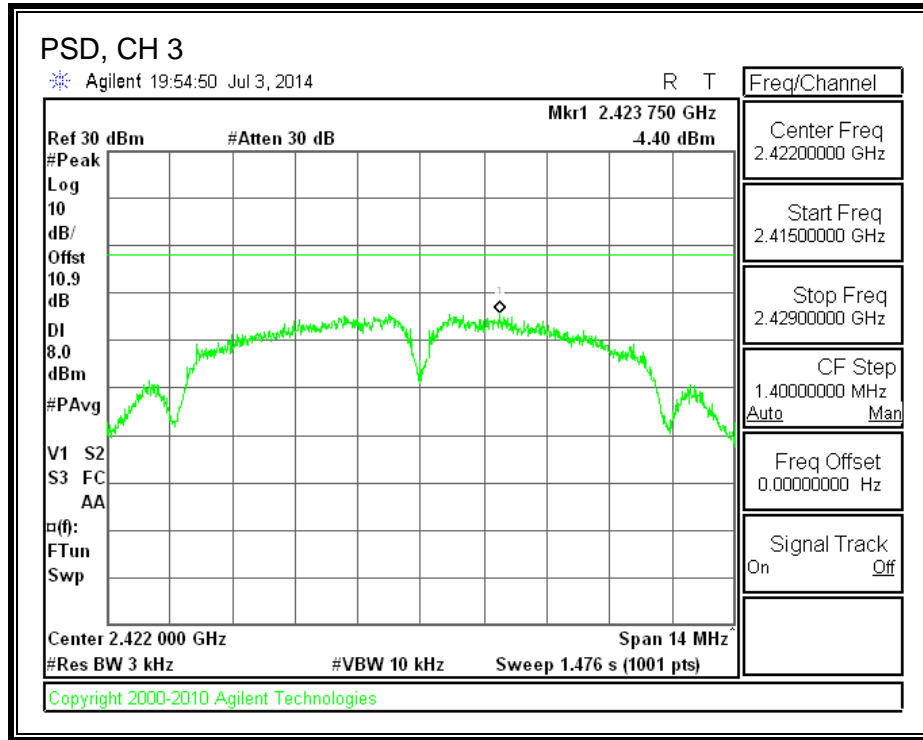

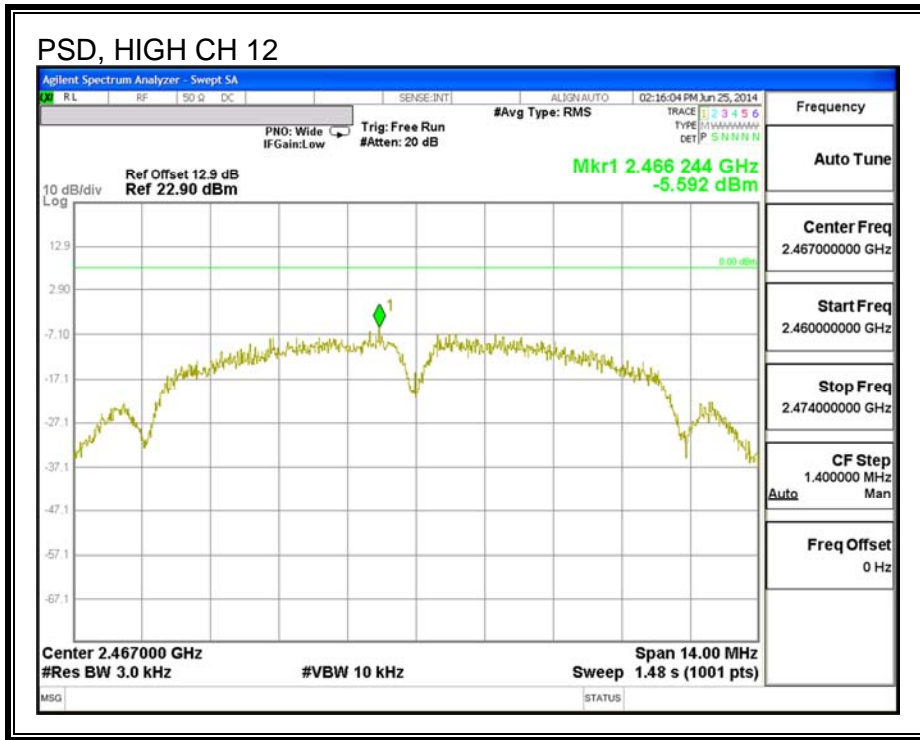
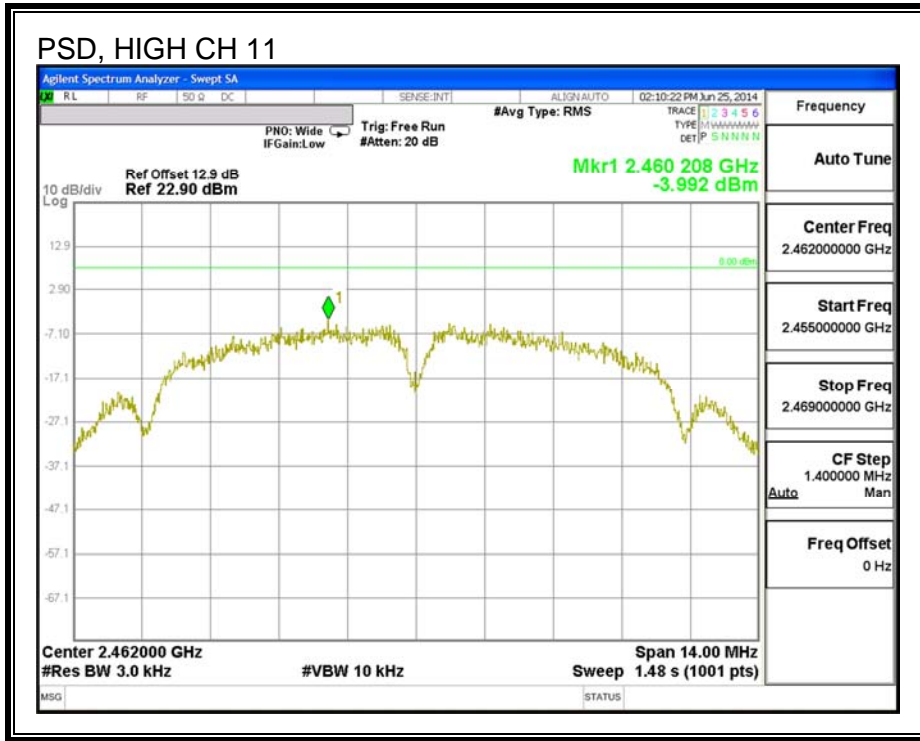

9.1.6. OUT-OF-BAND EMISSIONS

LIMITS

FCC §15.247 (d)

In any 100 kHz bandwidth outside the frequency band in which the spread spectrum or digitally modulated intentional radiator is operating, the radio frequency power that is produced by the intentional radiator shall be at least 20 dB below that in the 100 kHz bandwidth within the band that contains the highest level of the desired power, based on either an RF conducted or a radiated measurement, provided the transmitter demonstrates compliance with the peak conducted power limits. If the transmitter complies with the conducted power limits based on the use of RMS averaging over a time interval, as permitted under paragraph (b)(3) of this section, the attenuation required under this paragraph shall be 30 dB instead of 20 dB. Attenuation below the general limits specified in §15.209(a) is not required.

RESULTS

IN-BAND REFERENCE LEVEL

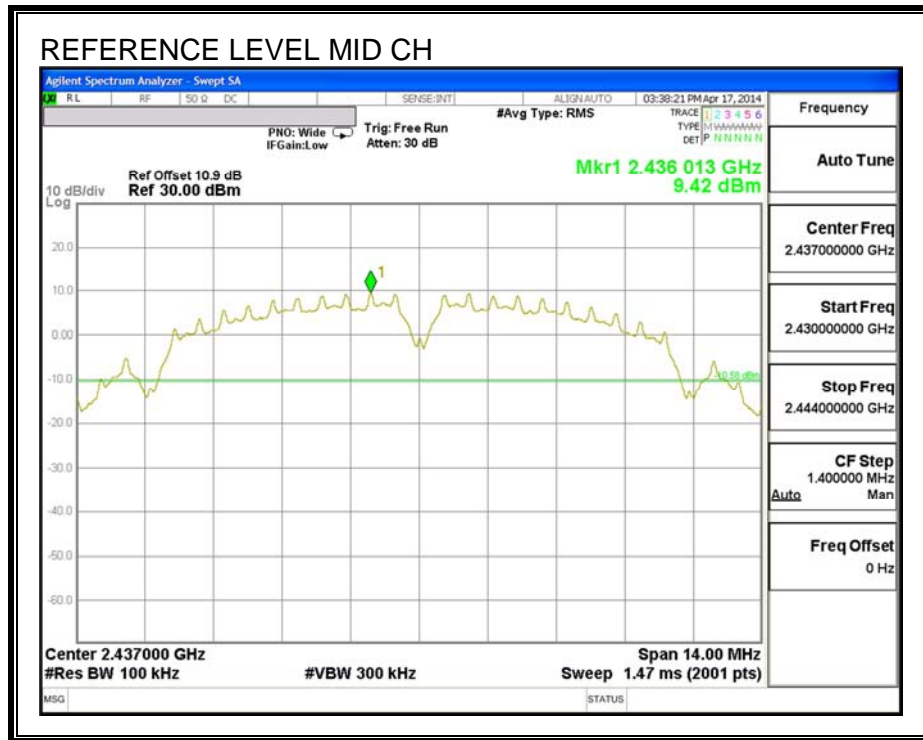

LOW CHANNEL BANDEDGE

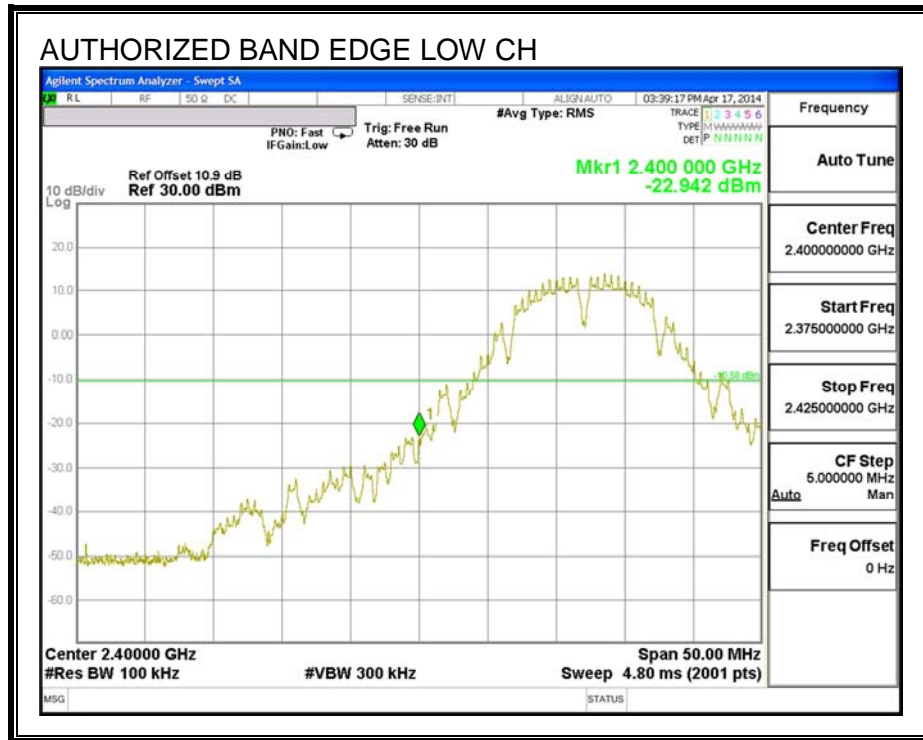

HIGH CHANNEL BANDEDGE

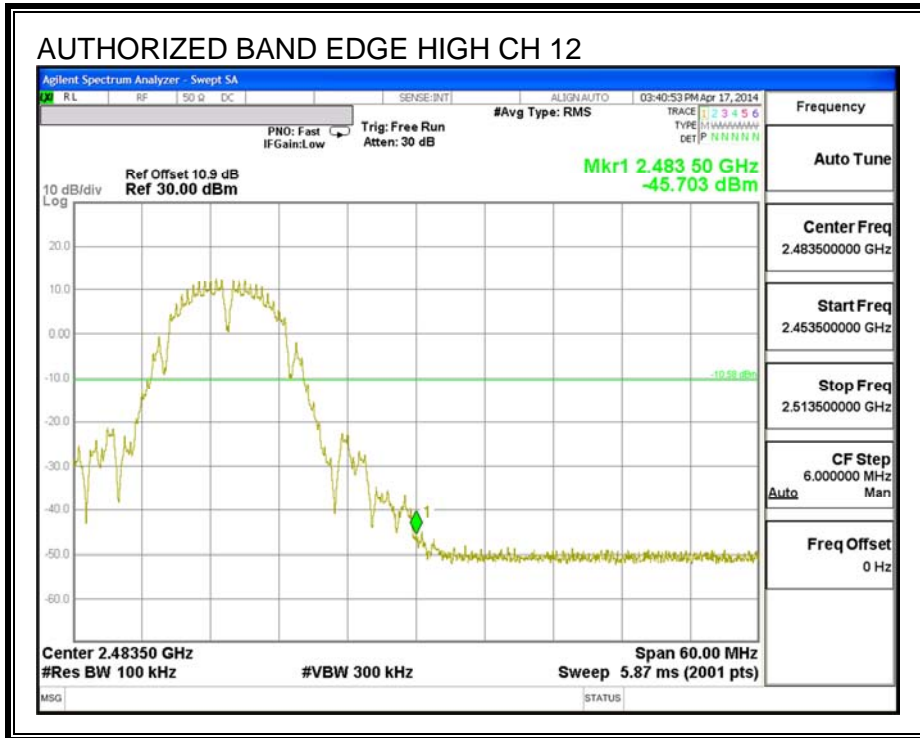
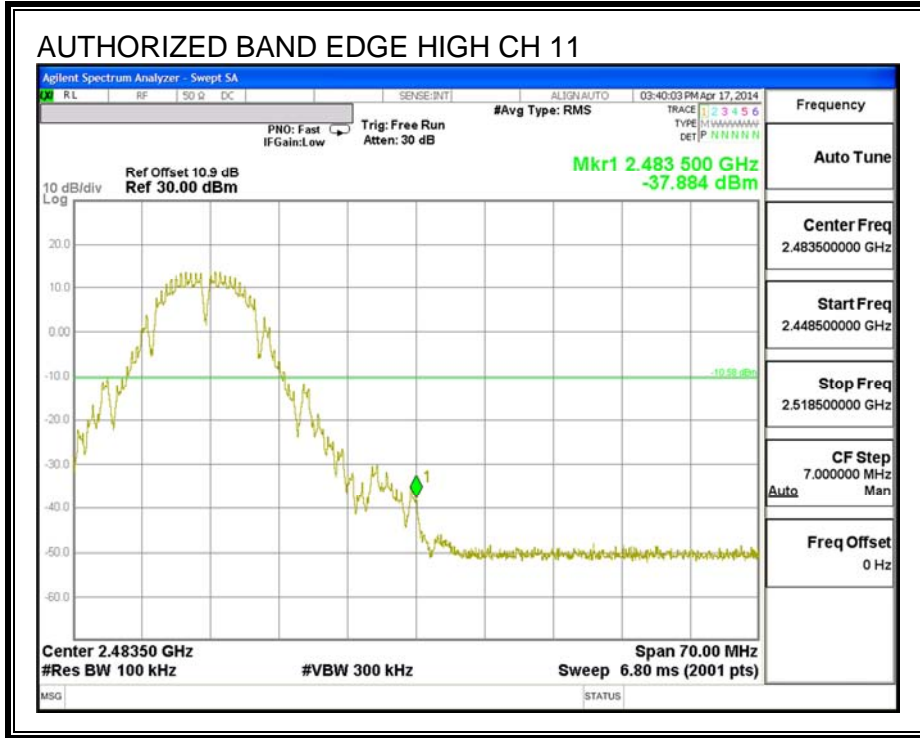

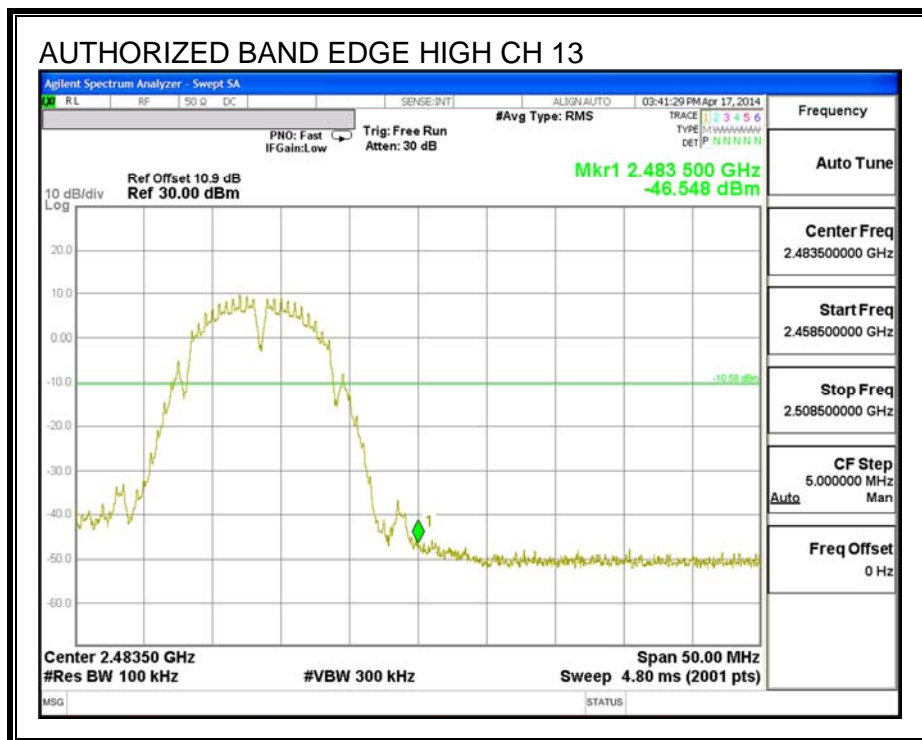

OUT-OF-BAND EMISSIONS

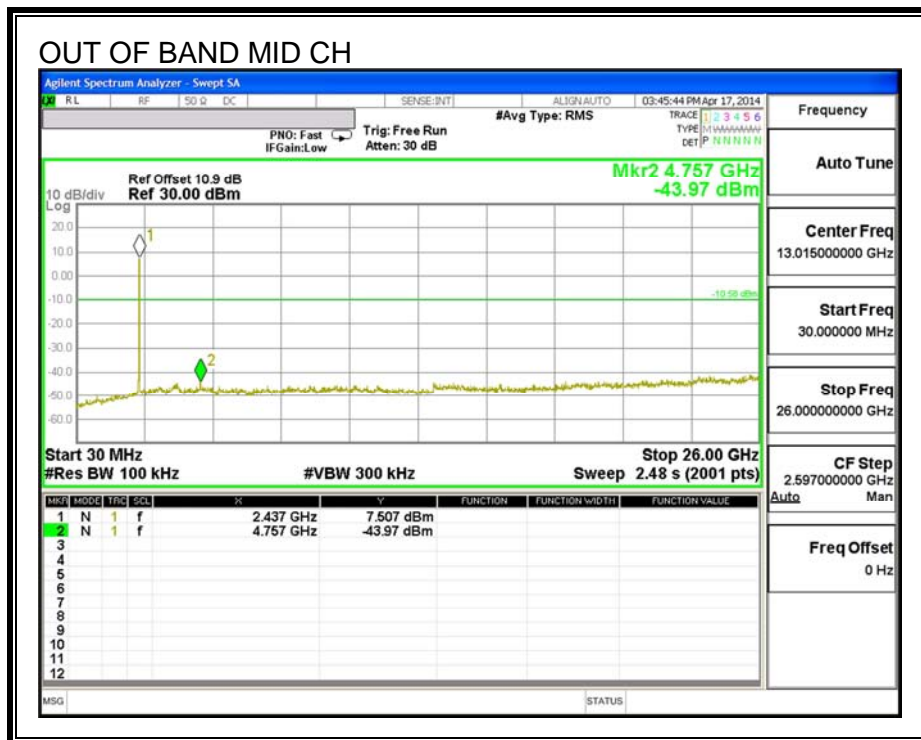
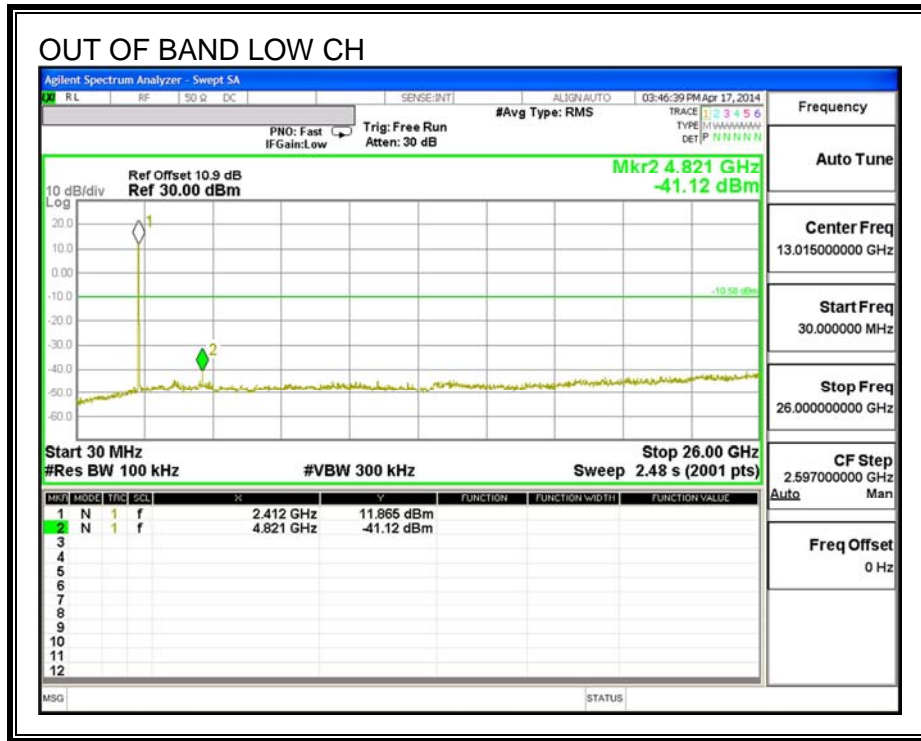

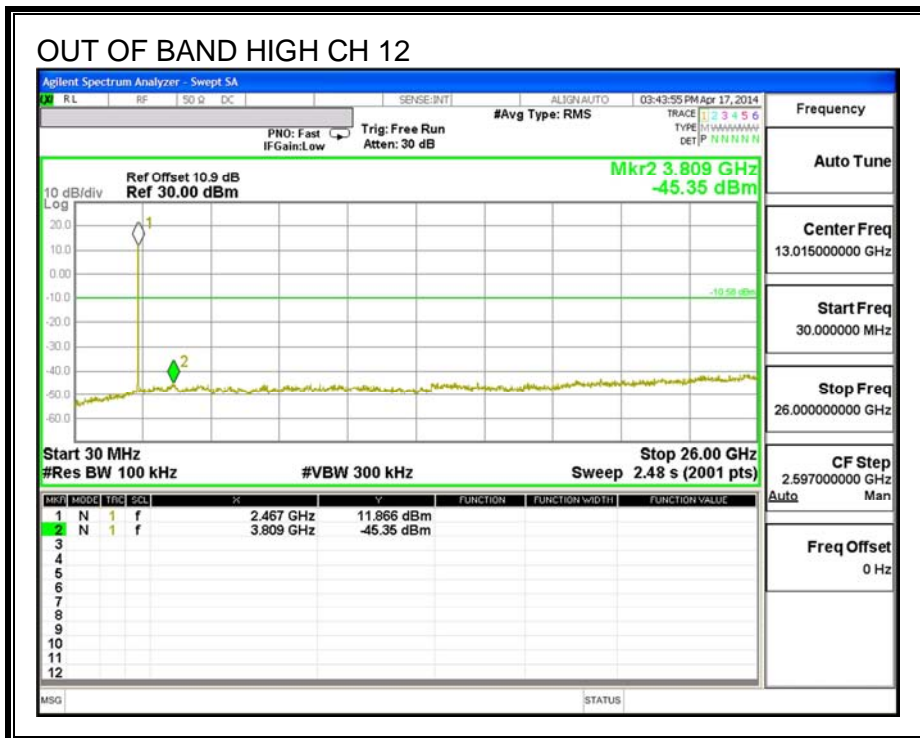
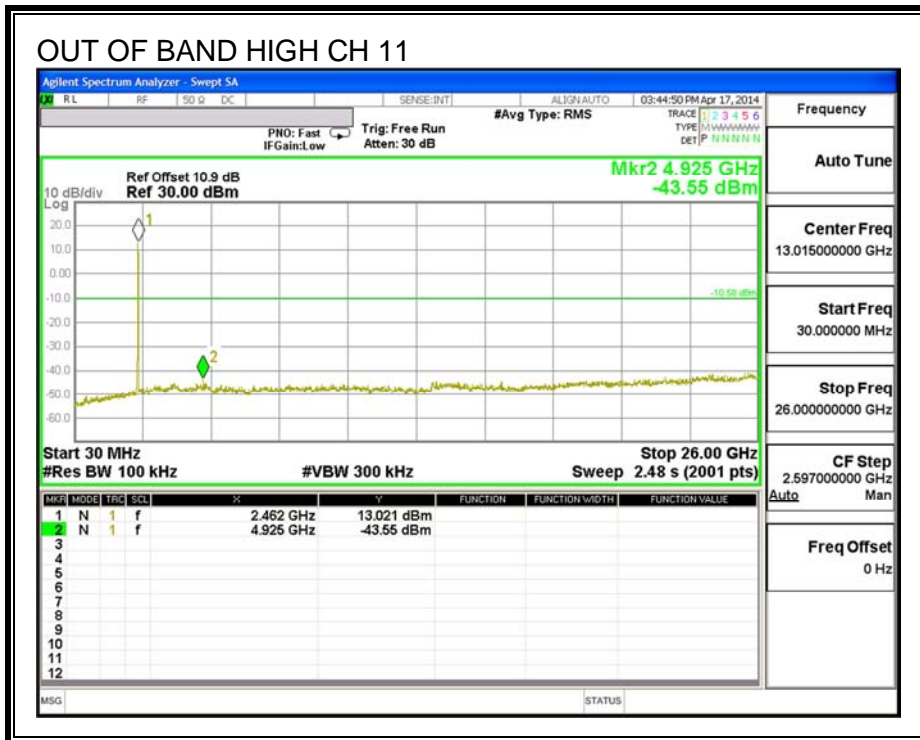

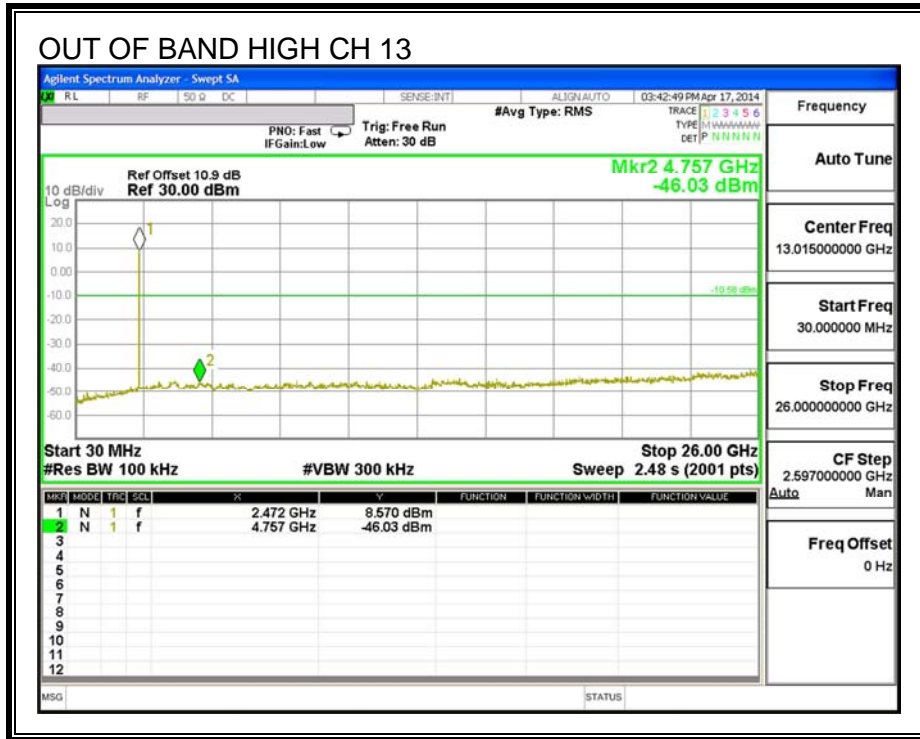

9.2. 802.11g MODE IN THE 2.4 GHz BAND

9.2.1. 6 dB BANDWIDTH

LIMITS

FCC §15.247 (a) (2)

The minimum 6 dB bandwidth shall be at least 500 kHz.

RESULTS

Channel	Frequency (MHz)	6 dB Bandwidth (MHz)	Minimum Limit (MHz)
Low	2412	15.792	0.5
Mid	2437	16.275	0.5
High	2462	16.125	0.5
High	2467	16.150	0.5
High	2472	15.792	0.5

6 dB BANDWIDTH

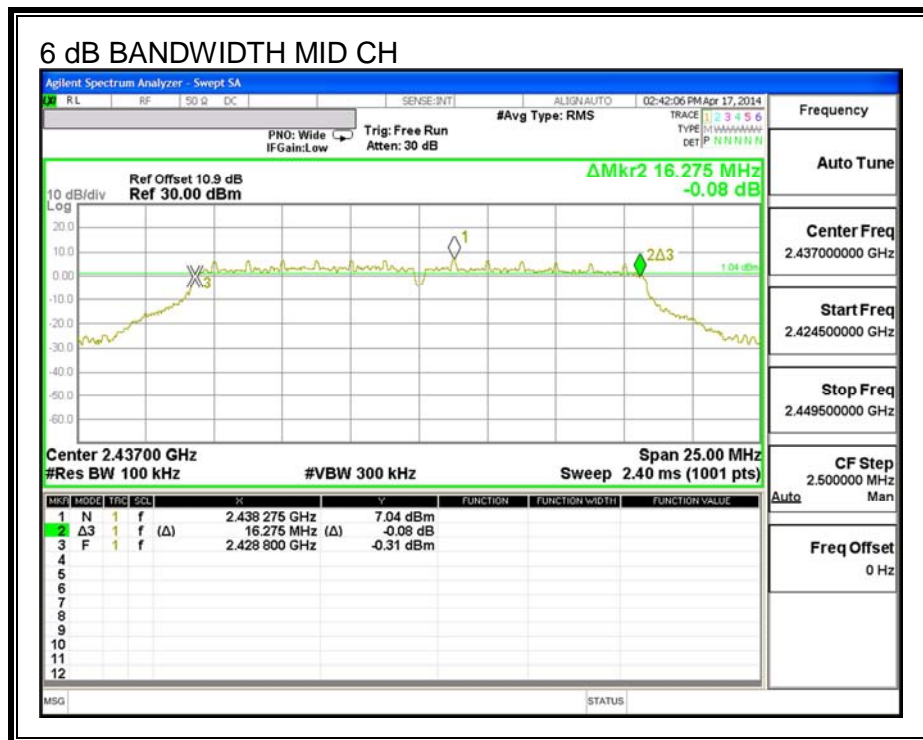
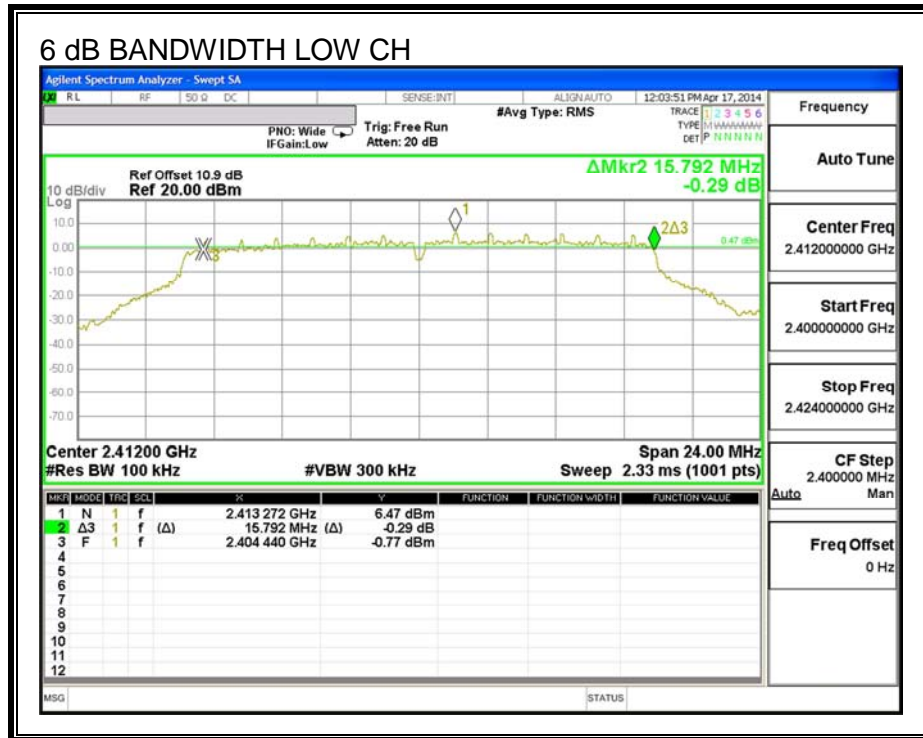

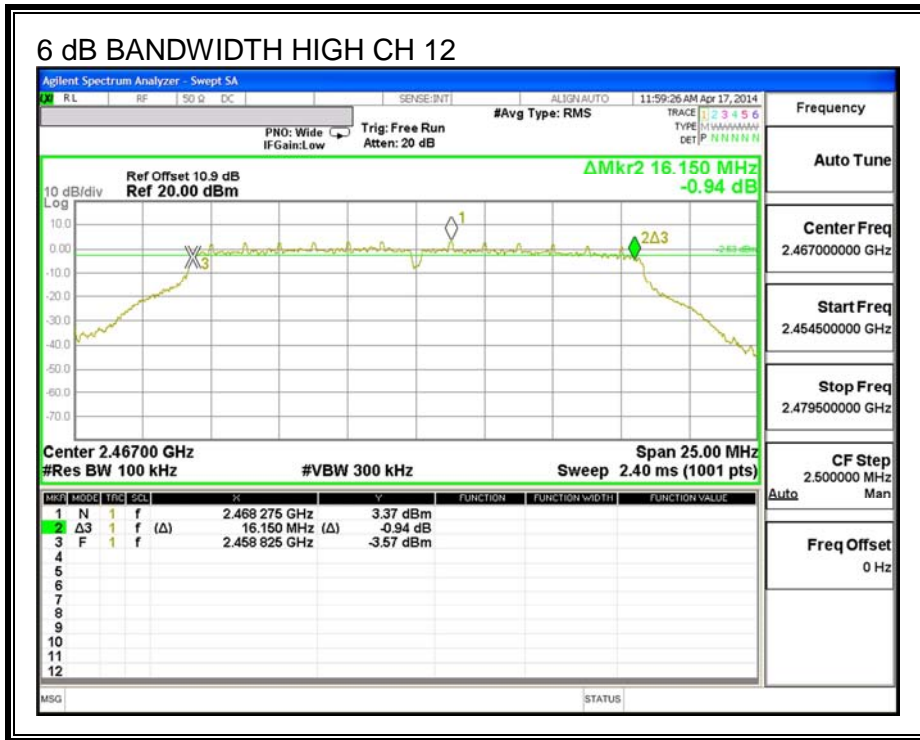
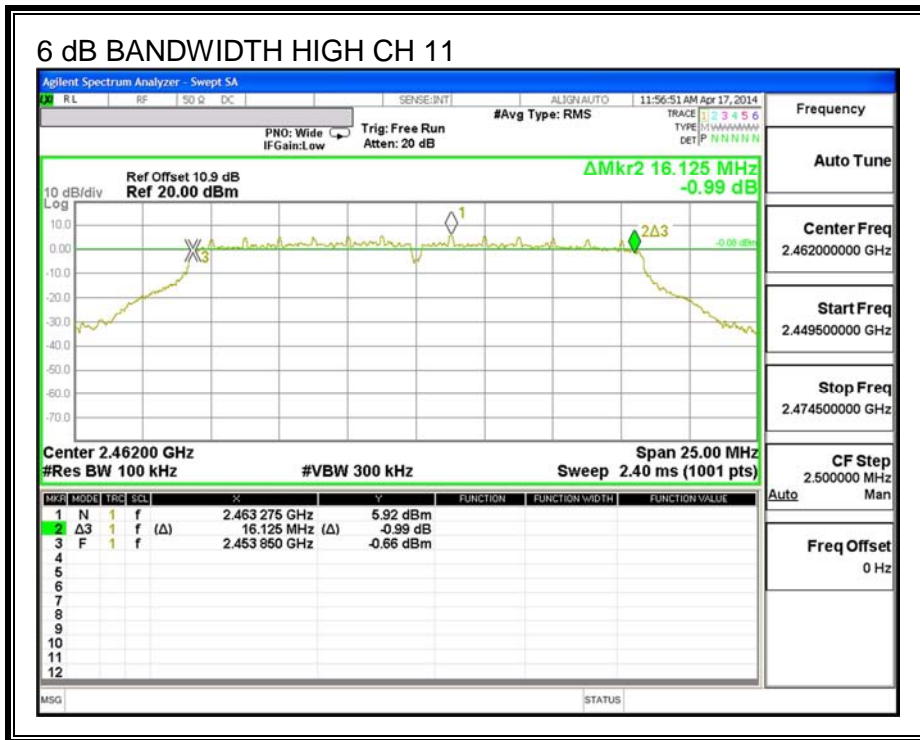

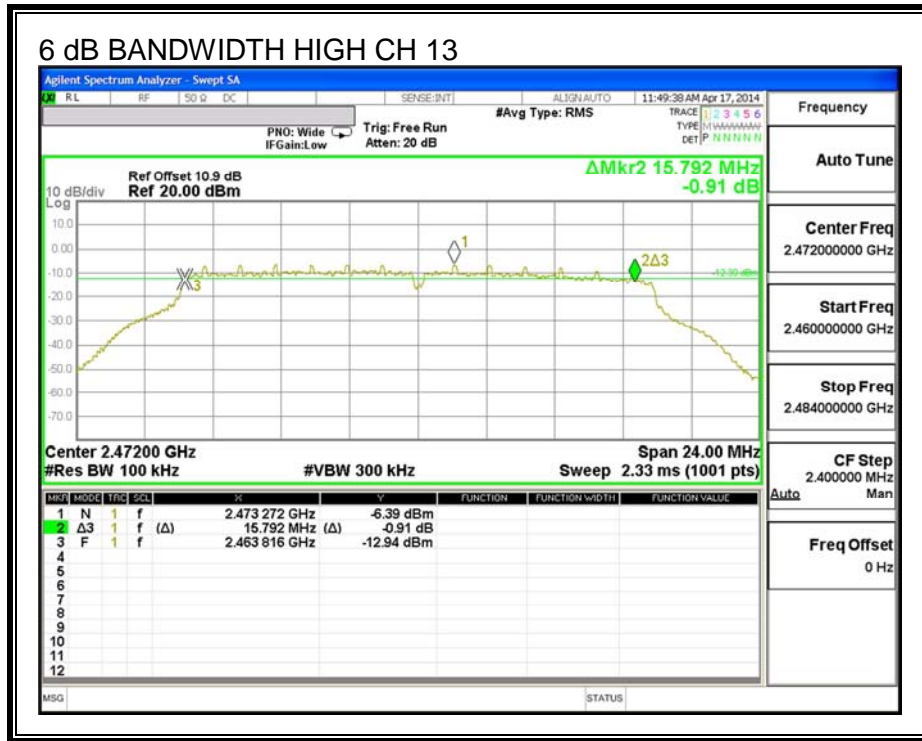

9.2.2. 99% BANDWIDTH

LIMITS

None; for reporting purposes only.

RESULTS

Channel	Frequency (MHz)	99% Bandwidth (MHz)
Low	2412	16.365
Mid	2437	16.390
High	2462	16.433
High	2467	16.444
High	2472	16.587

99% BANDWIDTH

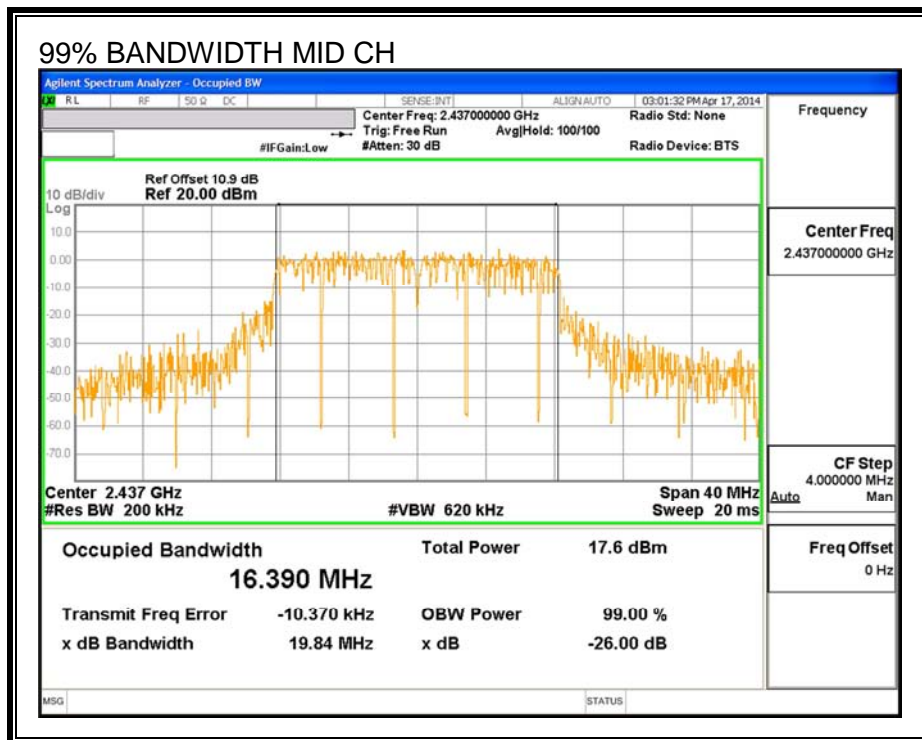
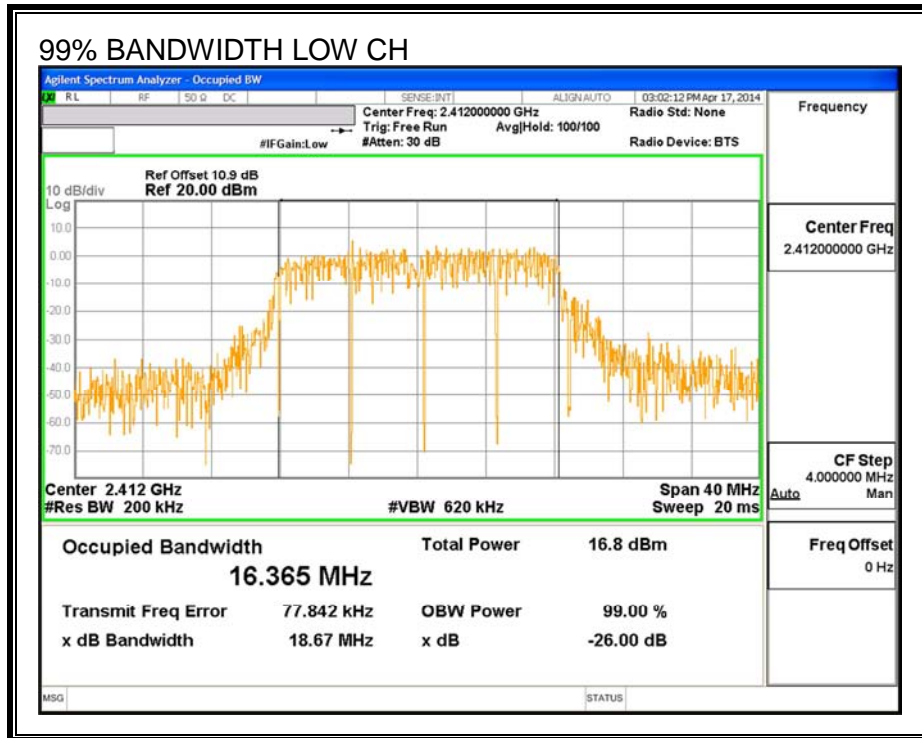

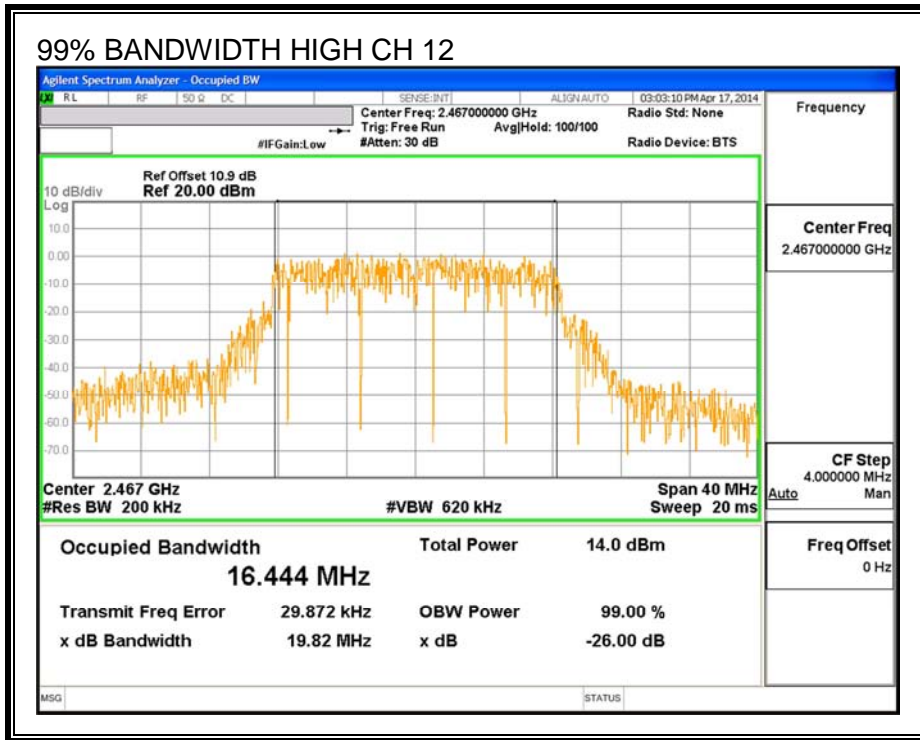
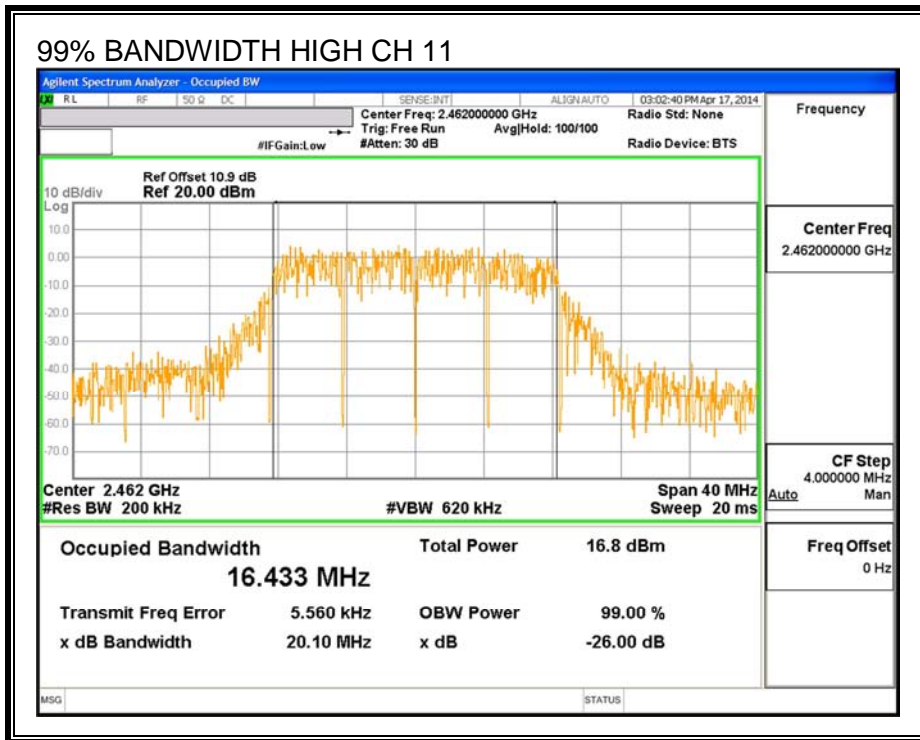

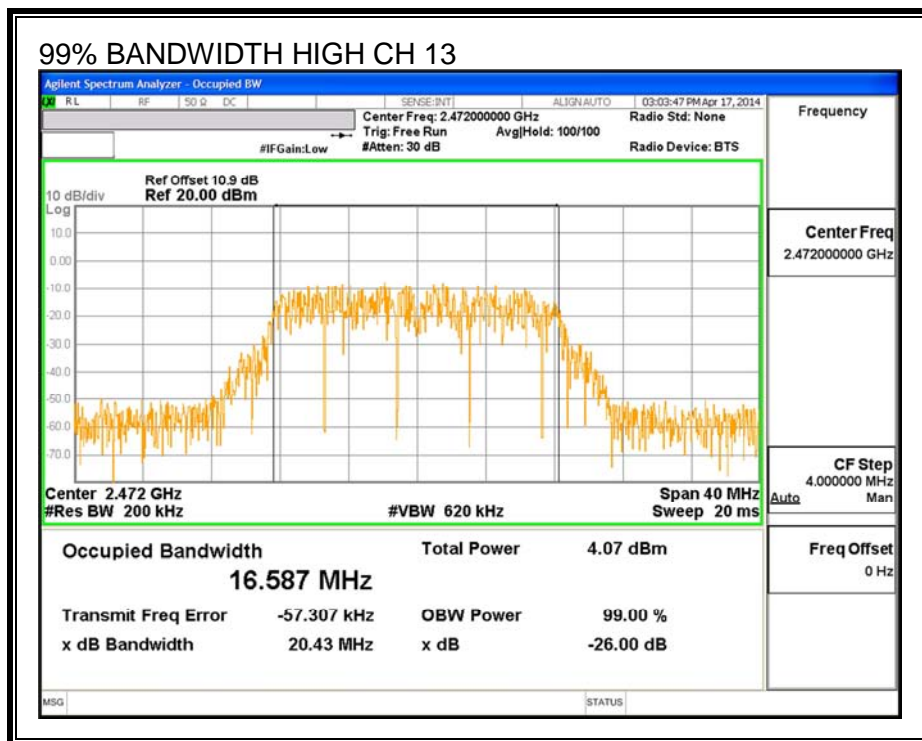

9.2.3. AVERAGE POWER

LIMITS

None; for reporting purposes only.

RESULTS

Channel	Frequency (MHz)	Power (dBm)
1	2412	13.93
2	2417	15.50
3	2422	17.00
6	2437	17.96
11	2462	15.97
12	2467	11.99
13	2472	5.00

9.2.1. OUTPUT POWER

LIMITS

FCC §15.247

For systems using digital modulation in the 902–928 MHz, 2400–2483.5 MHz, and 5725–5850 MHz bands: 1 Watt, based on the use of antennas with directional gains that do not exceed 6 dBi. If transmitting antennas of directional gain greater than 6 dBi are used, the conducted output power from the intentional radiator shall be reduced by the amount in dB that the directional gain of the antenna exceeds 6 dBi.

DIRECTIONAL ANTENNA GAIN

There is only one transmitter output therefore the directional gain is equal to the antenna gain.

RESULTS

Limits

Channel	Frequency (MHz)	Directional Gain (dBi)	FCC Power Limit (dBm)
1	2412	-0.38	30.00
2	2417	-0.38	30.00
3	2422	-0.38	30.00
6	2437	-0.38	30.00
11	2462	-0.38	30.00
12	2467	-0.38	30.00
13	2472	-0.38	30.00

Results

Channel	Frequency (MHz)	Meas Power (dBm)	Total Corr'd Power (dBm)	Power Limit (dBm)	Margin (dB)
1	2412	23.65	23.65	30.00	-6.35
2	2417	24.27	24.27	30.00	-5.73
3	2422	24.57	24.57	30.00	-5.43
6	2437	24.99	24.99	30.00	-5.01
11	2462	24.48	24.48	30.00	-5.52
12	2467	22.80	22.80	30.00	-7.20
13	2472	11.87	11.87	30.00	-18.13

9.2.2. PSD

LIMITS

FCC §15.247 (e)

For digitally modulated systems, the power spectral density conducted from the intentional radiator to the antenna shall not be greater than 8 dBm in any 3 kHz band during any time interval of continuous transmission. This power spectral density shall be determined in accordance with the provisions of paragraph (b) of this section. The same method of determining the conducted output power shall be used to determine the power spectral density.

RESULTS

PSD Results

Channel	Frequency (MHz)	Meas (dBm)	Limit (dBm)	Margin (dB)
1	2412	-7.31	8.0	-15.3
2	2417	-8.95	8.0	-17.0
3	2422	-7.41	8.0	-15.4
6	2437	-7.21	8.0	-15.2
11	2462	-7.88	8.0	-15.9
12	2467	-10.98	8.0	-19.0
13	2472	-19.88	8.0	-27.9

PSD

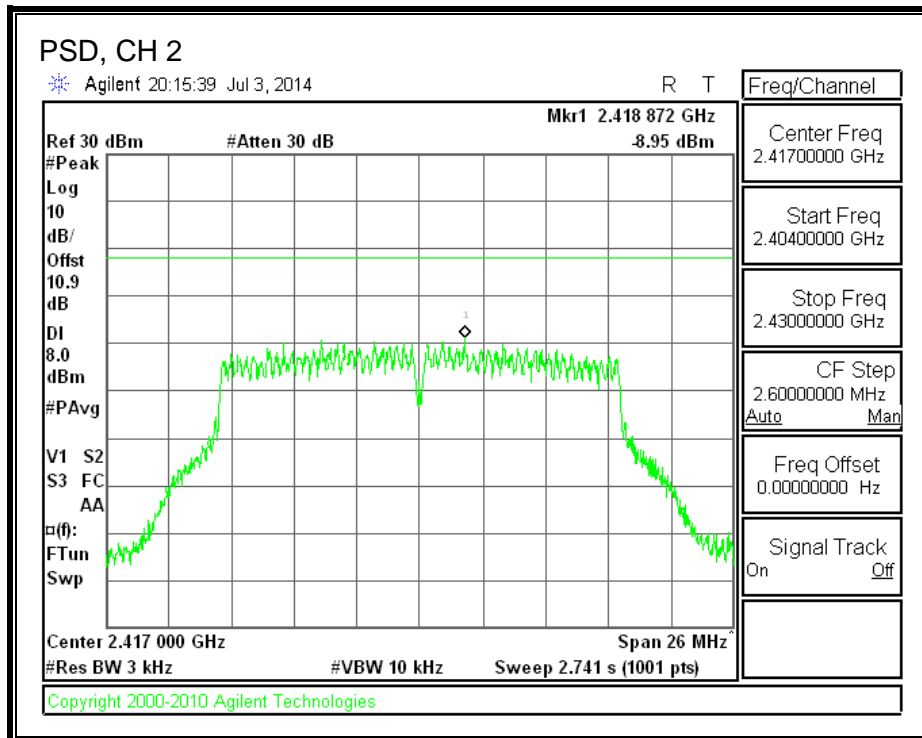
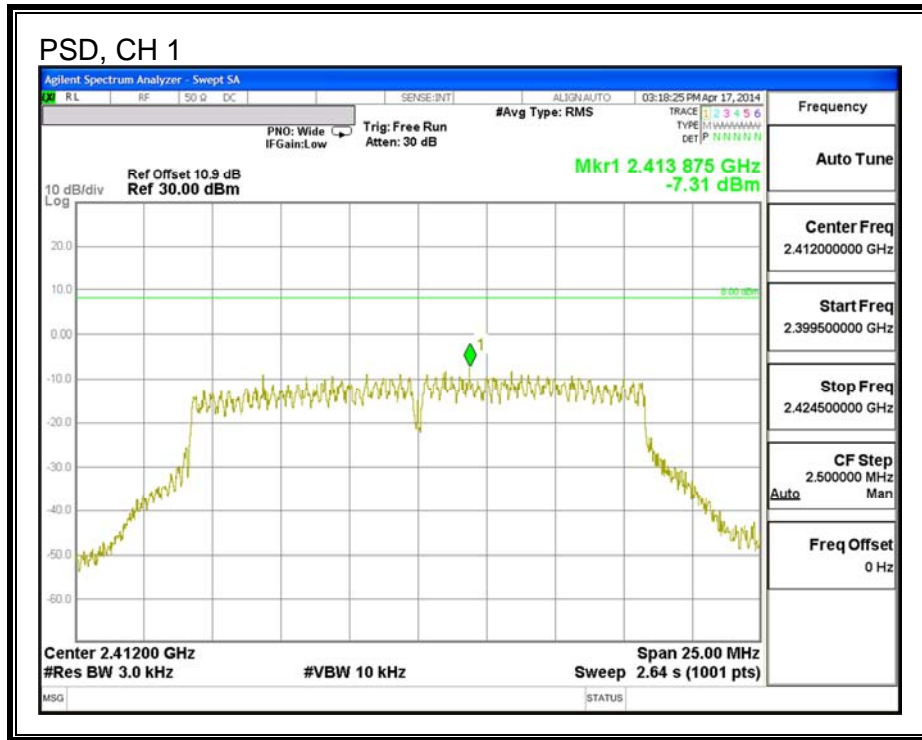

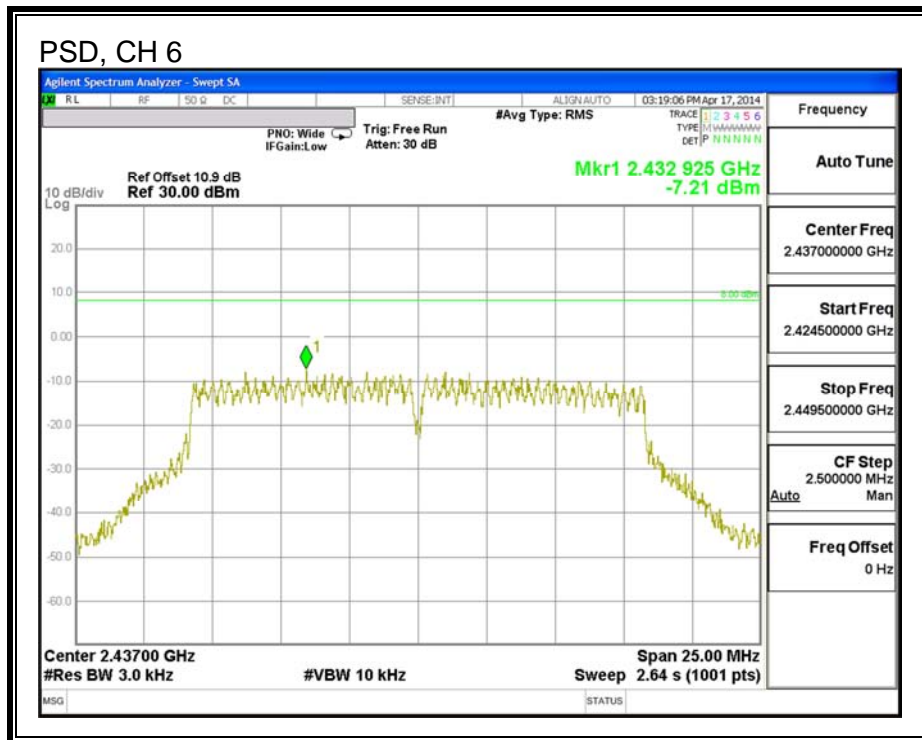
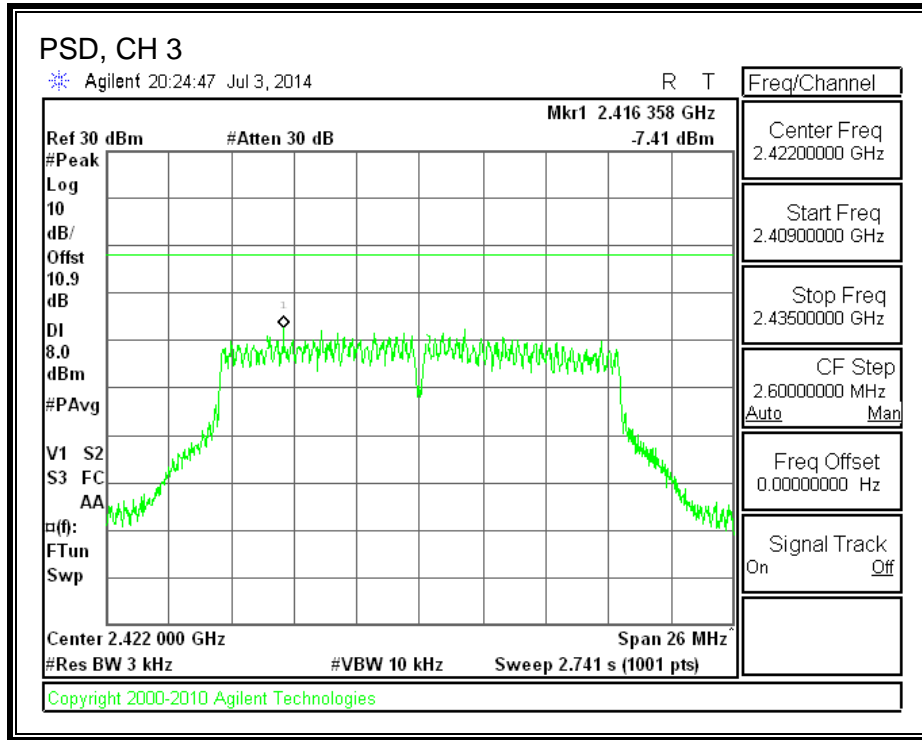

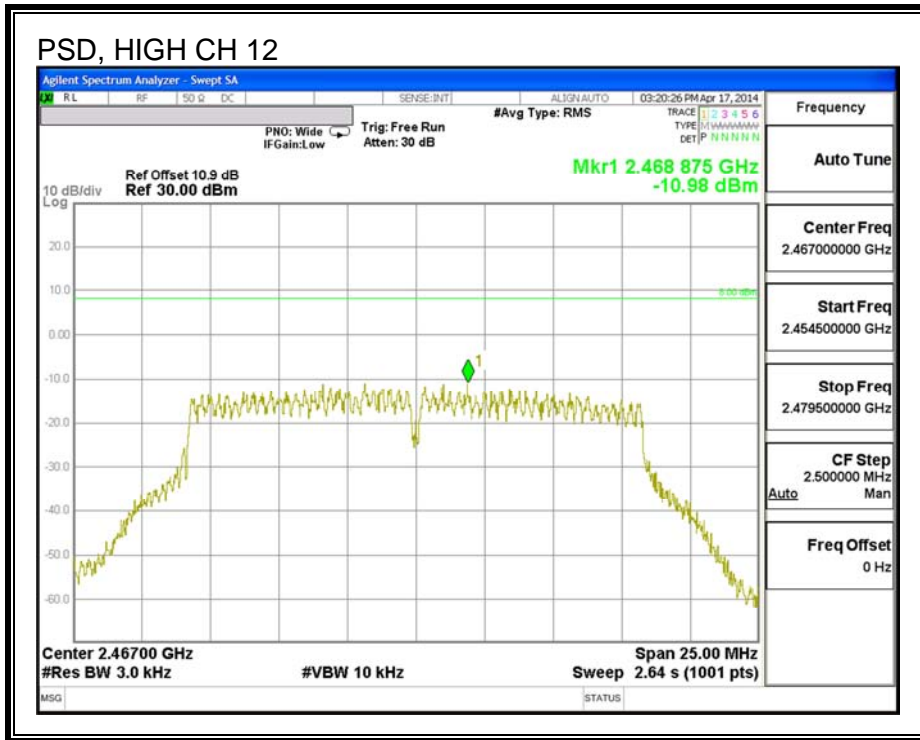
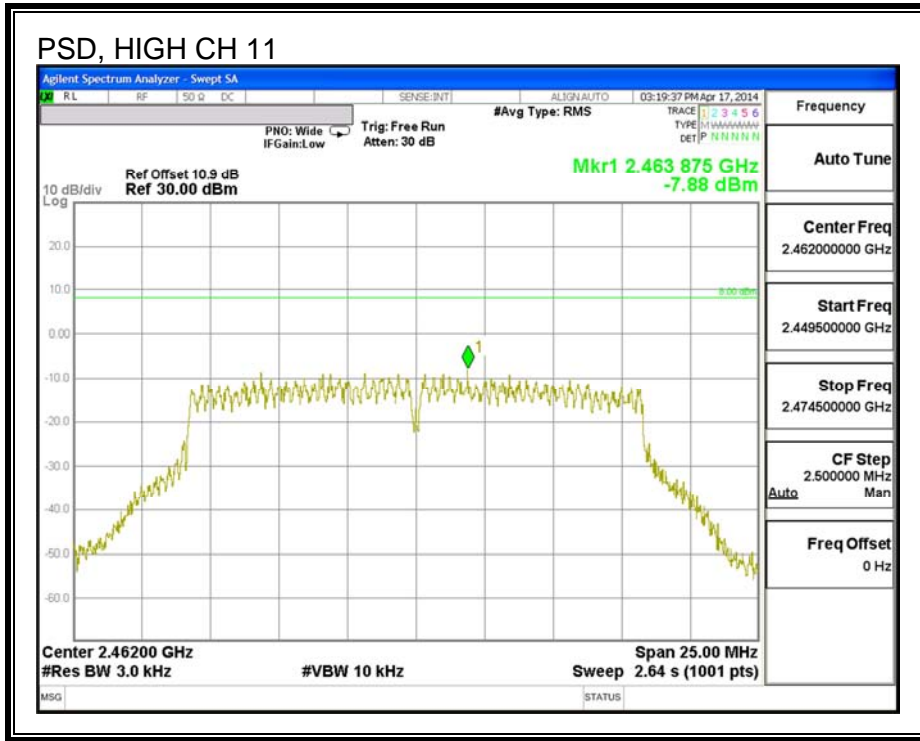

9.2.3. OUT-OF-BAND EMISSIONS

LIMITS

FCC §15.247 (d)

In any 100 kHz bandwidth outside the frequency band in which the spread spectrum or digitally modulated intentional radiator is operating, the radio frequency power that is produced by the intentional radiator shall be at least 20 dB below that in the 100 kHz bandwidth within the band that contains the highest level of the desired power, based on either an RF conducted or a radiated measurement, provided the transmitter demonstrates compliance with the peak conducted power limits. If the transmitter complies with the conducted power limits based on the use of RMS averaging over a time interval, as permitted under paragraph (b)(3) of this section, the attenuation required under this paragraph shall be 30 dB instead of 20 dB. Attenuation below the general limits specified in §15.209(a) is not required.

HIGH CHANNEL BANDEDGE

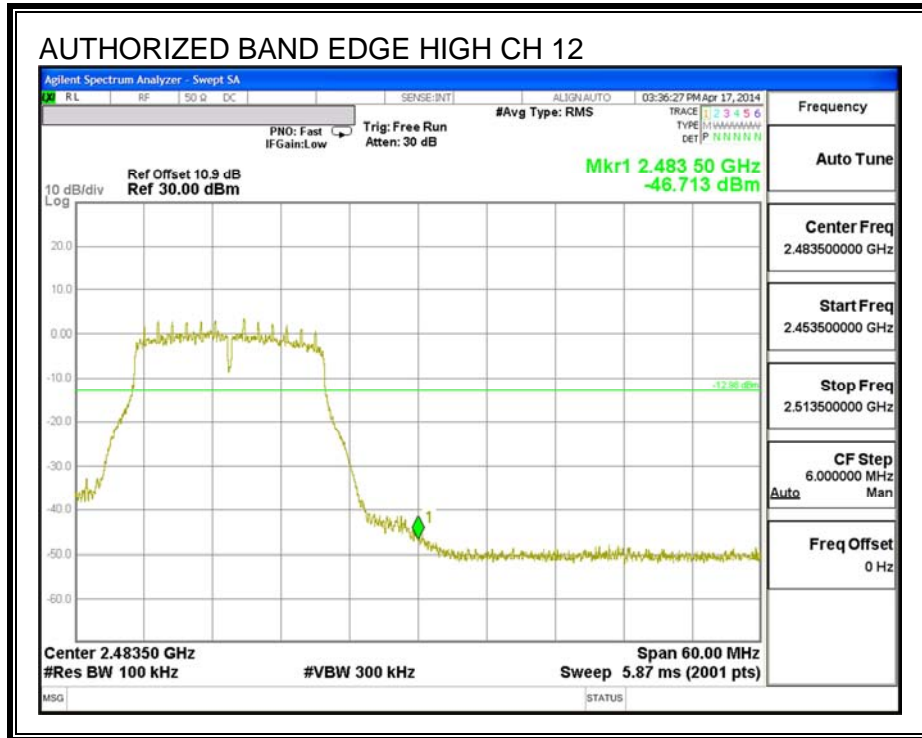
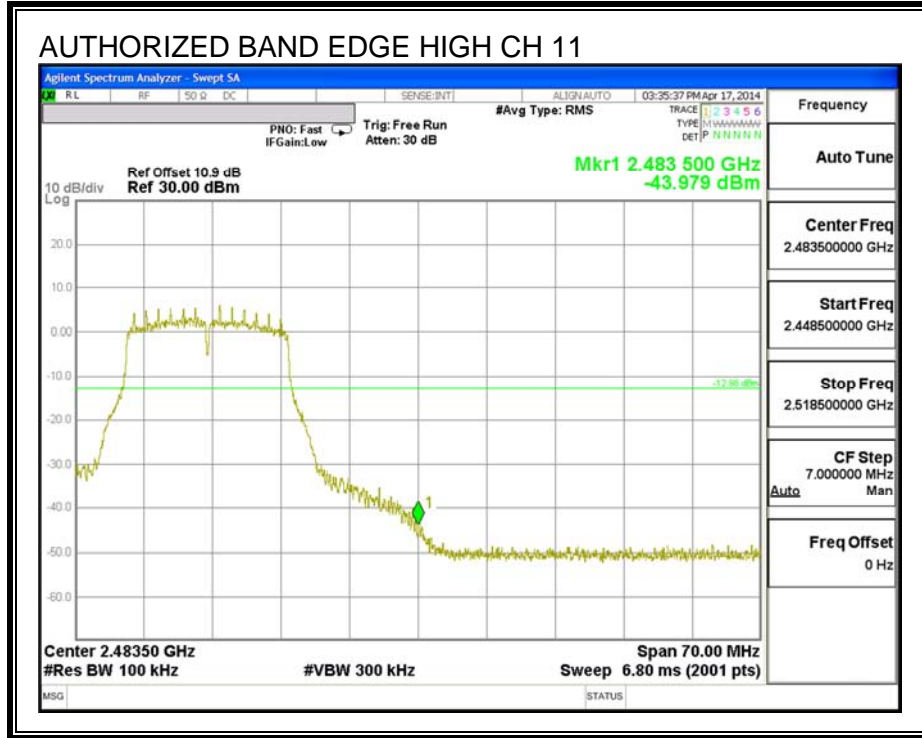

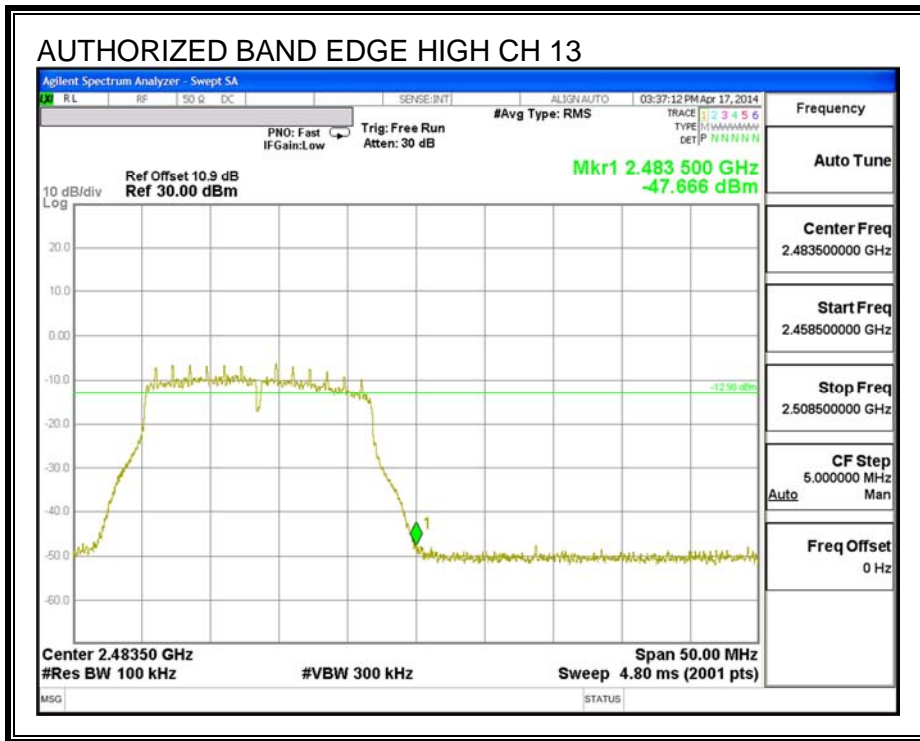

OUT-OF-BAND EMISSIONS

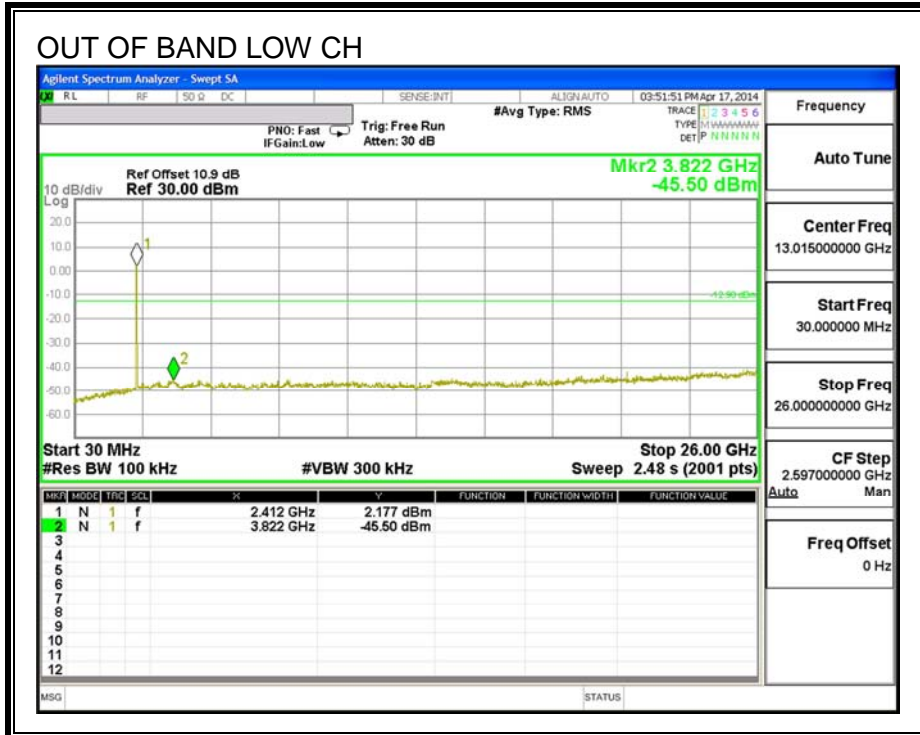

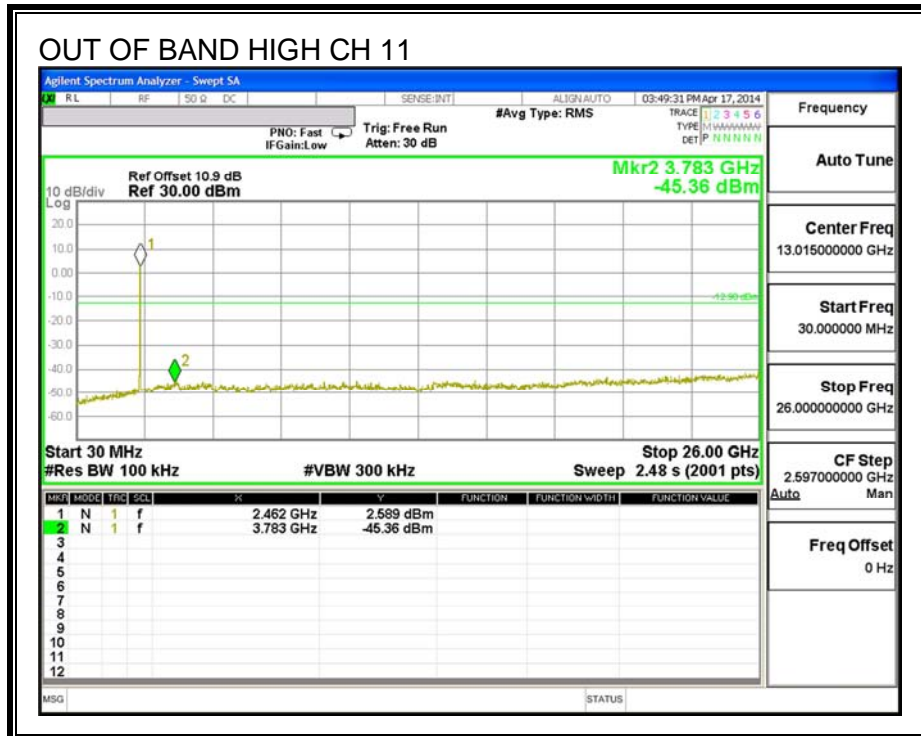
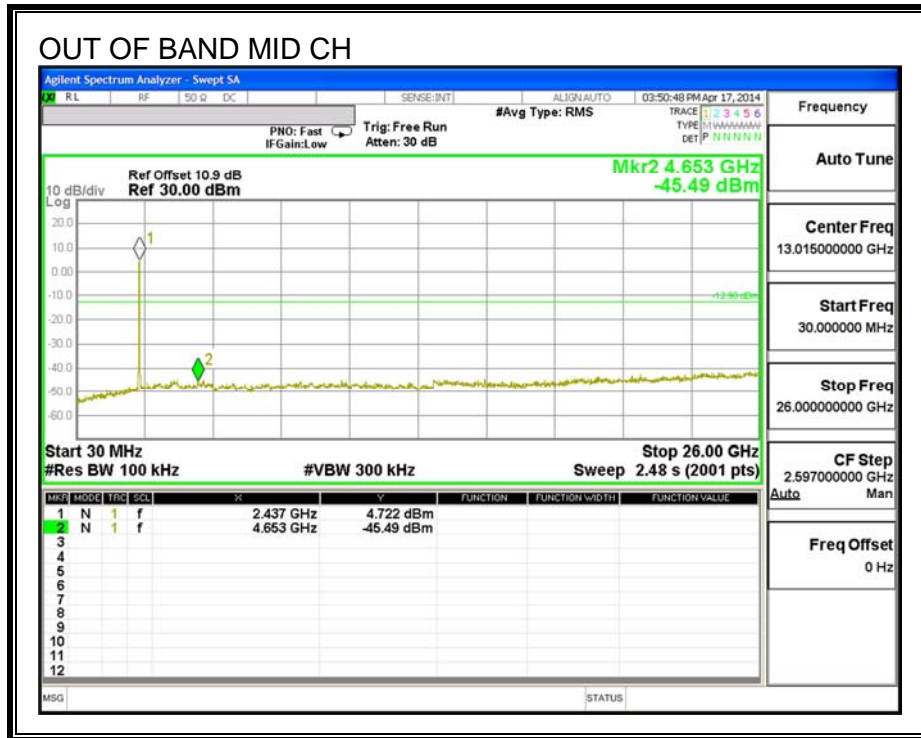

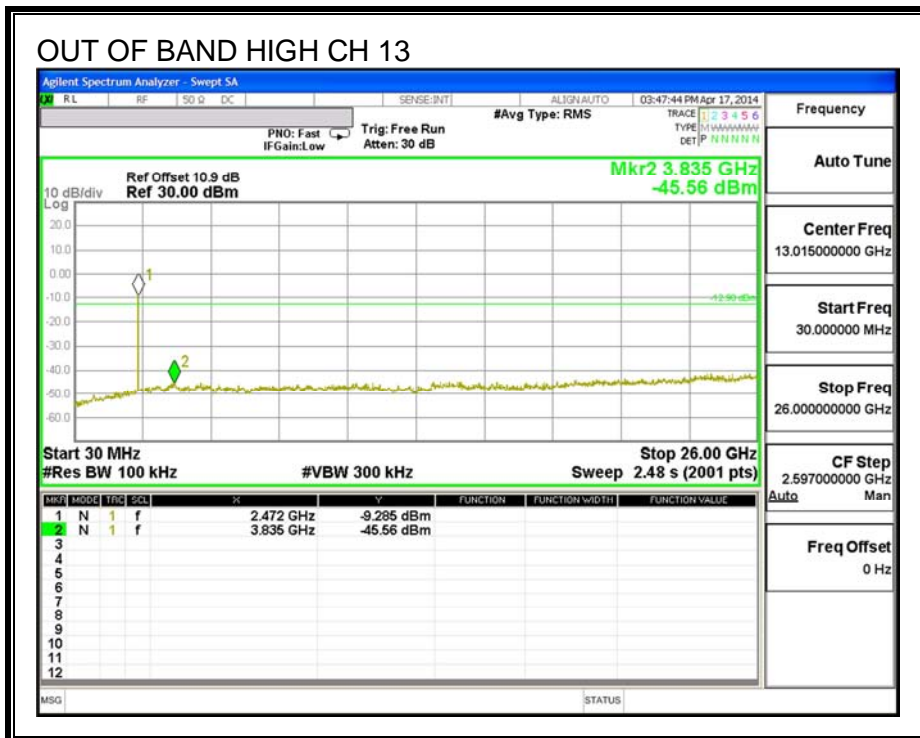
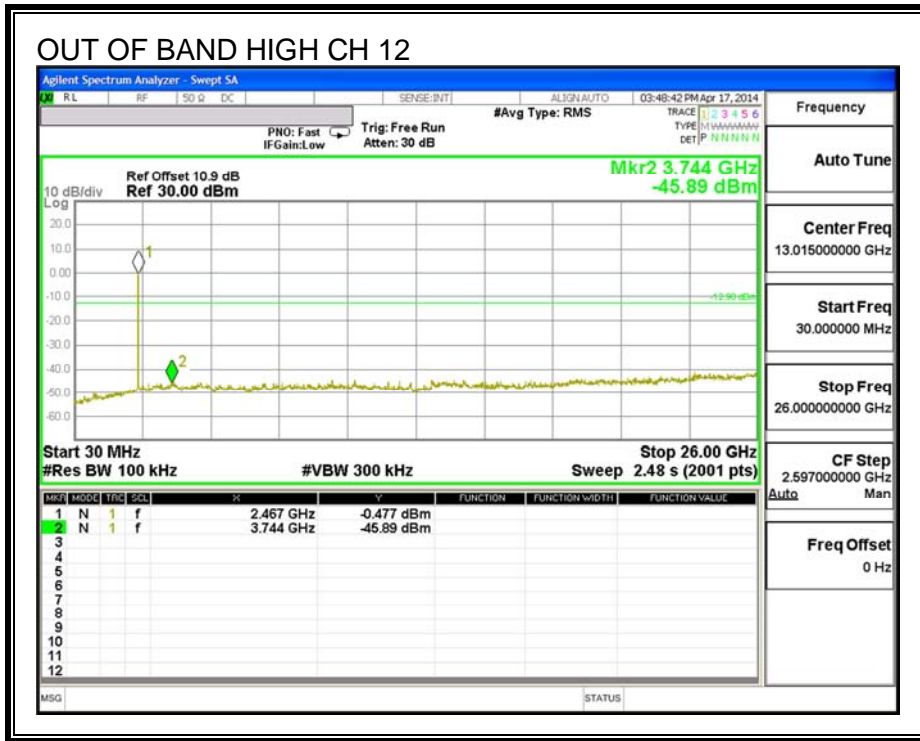

9.3. 802.11n HT20 1Tx SISO MODE IN THE 2.4 GHz BAND

9.3.1. 6 dB BANDWIDTH

LIMITS

FCC §15.247 (a) (2)

The minimum 6 dB bandwidth shall be at least 500 kHz.

RESULTS

Channel	Frequency (MHz)	6 dB Bandwidth (MHz)	Minimum Limit (MHz)
Low	2412	16.375	0.5
Mid	2437	17.368	0.5
High	2462	16.375	0.5
High	2467	16.800	0.5
High	2472	16.375	0.5

6 dB BANDWIDTH

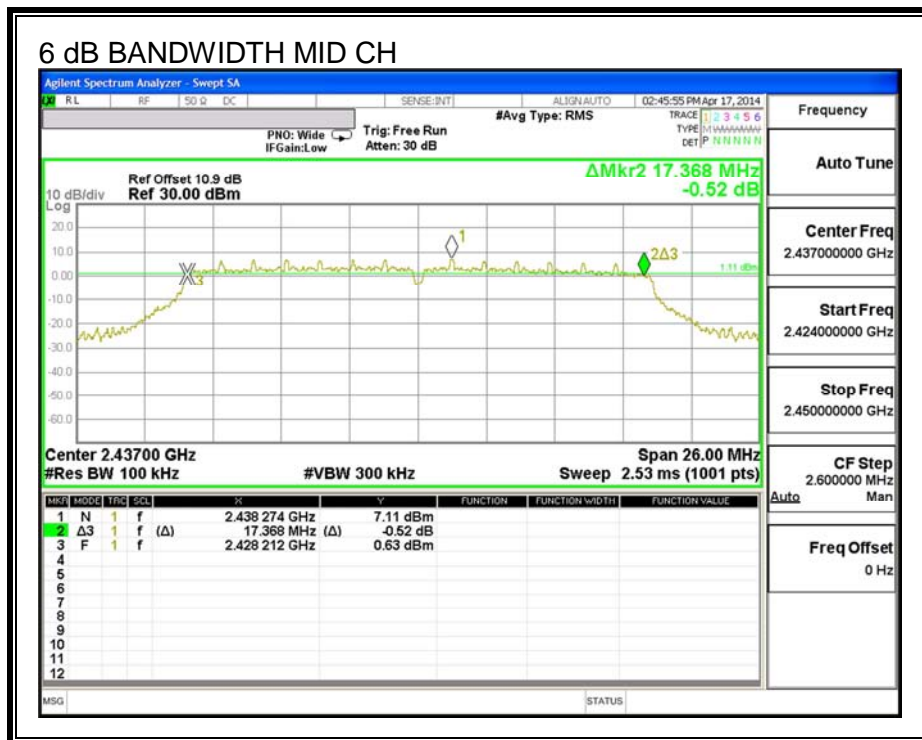
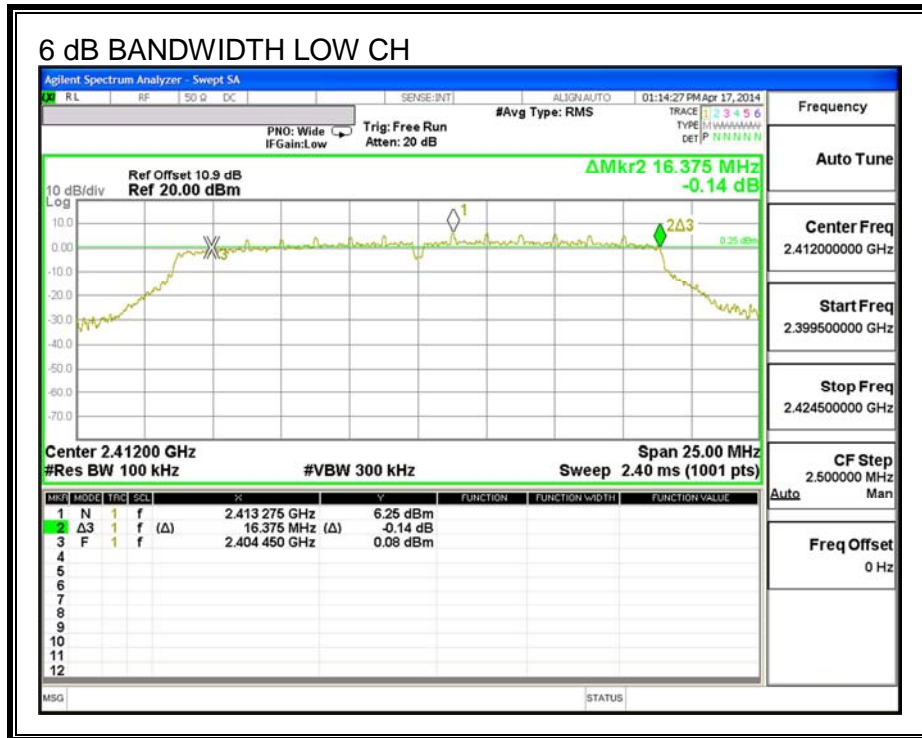

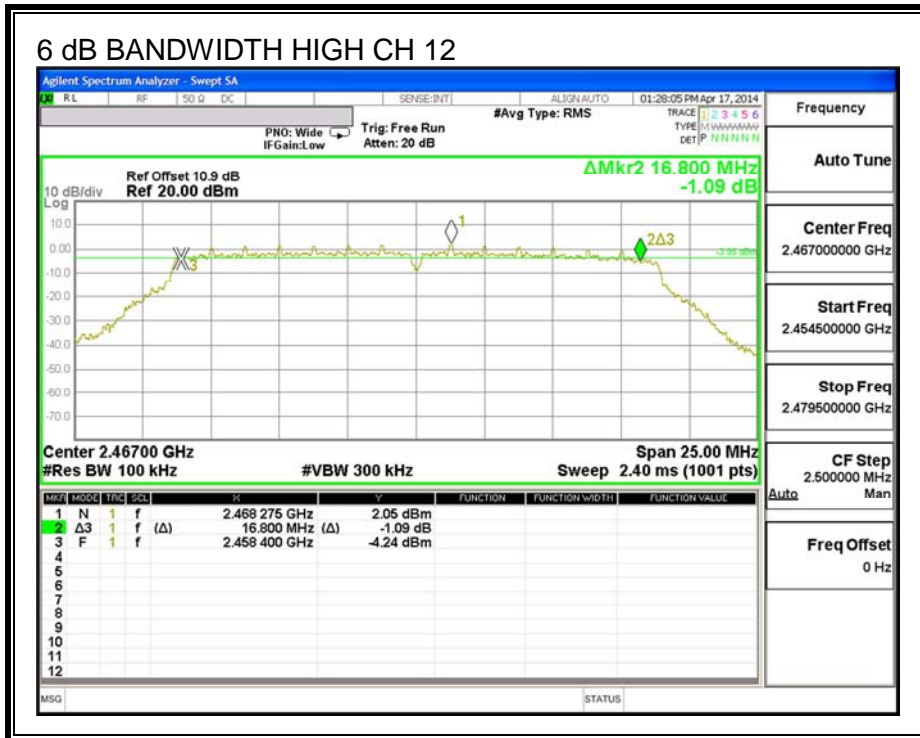
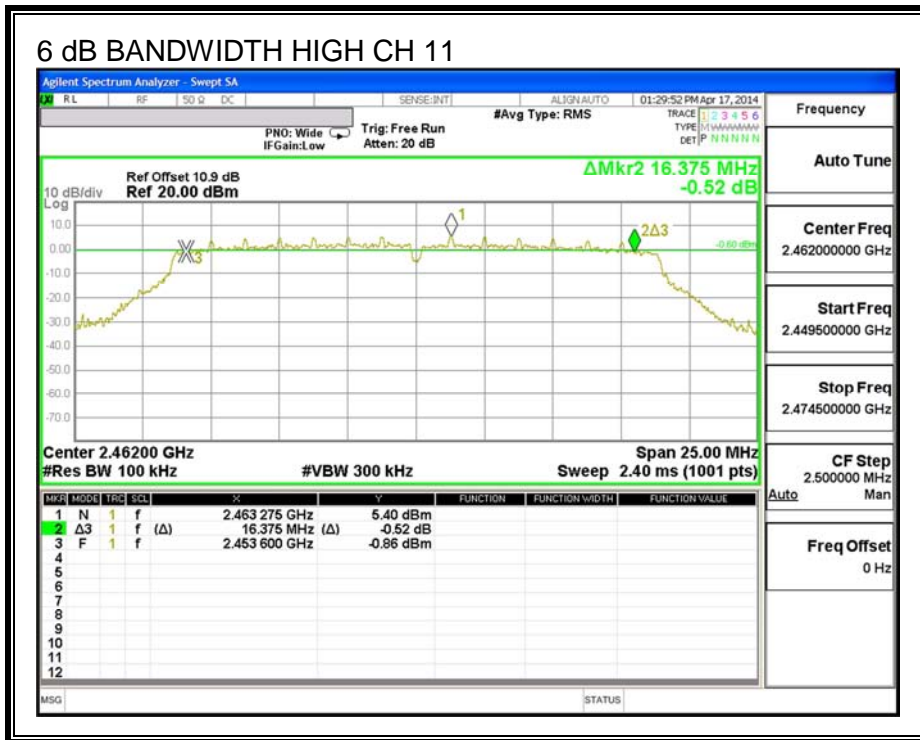

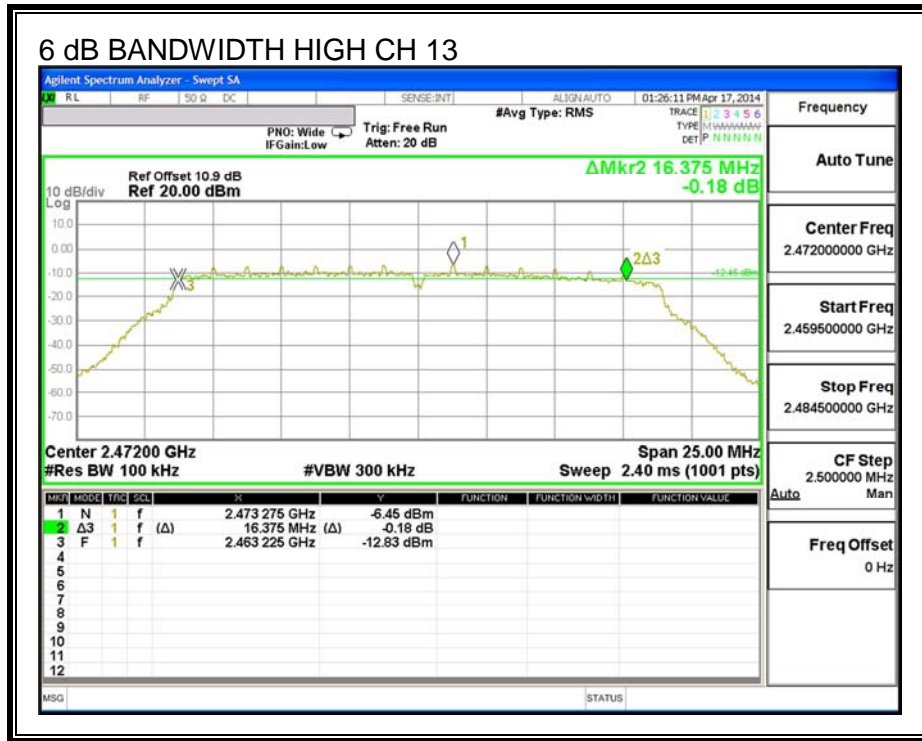

9.3.2. 99% BANDWIDTH

LIMITS

None; for reporting purposes only.

RESULTS

Channel	Frequency (MHz)	99% Bandwidth (MHz)
Low	2412	17.521
Mid	2437	17.610
High	2462	17.549
High	2467	17.574
High	2472	17.530

99% BANDWIDTH

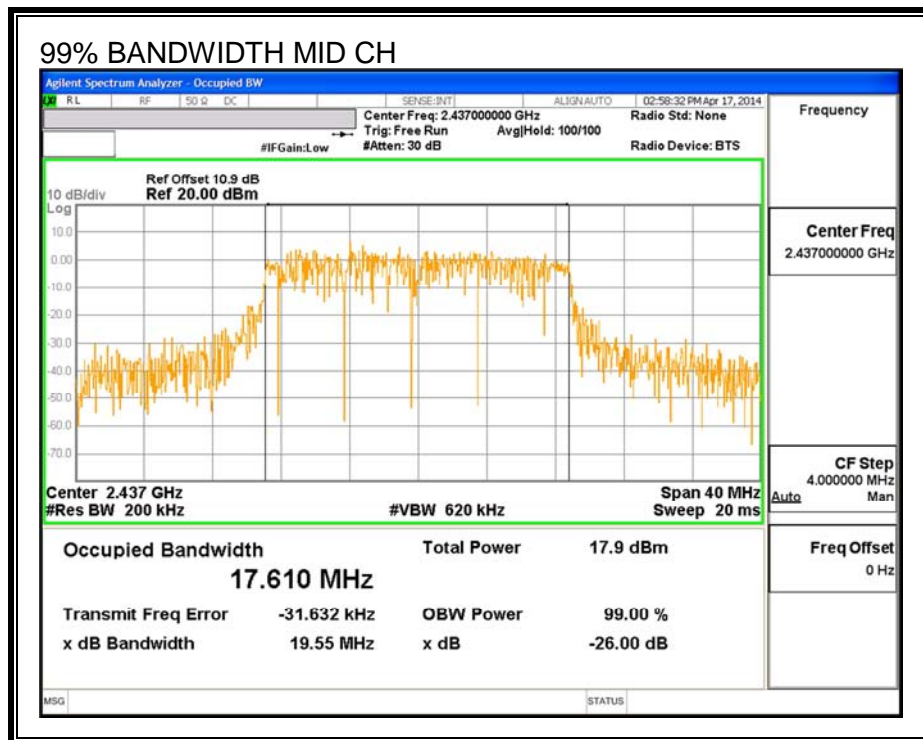
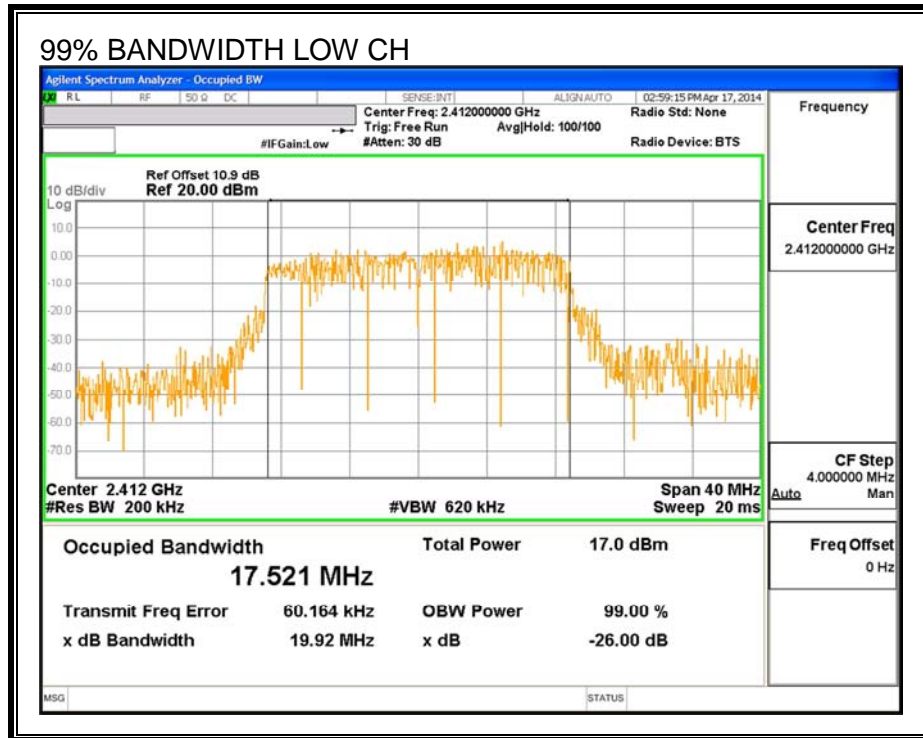

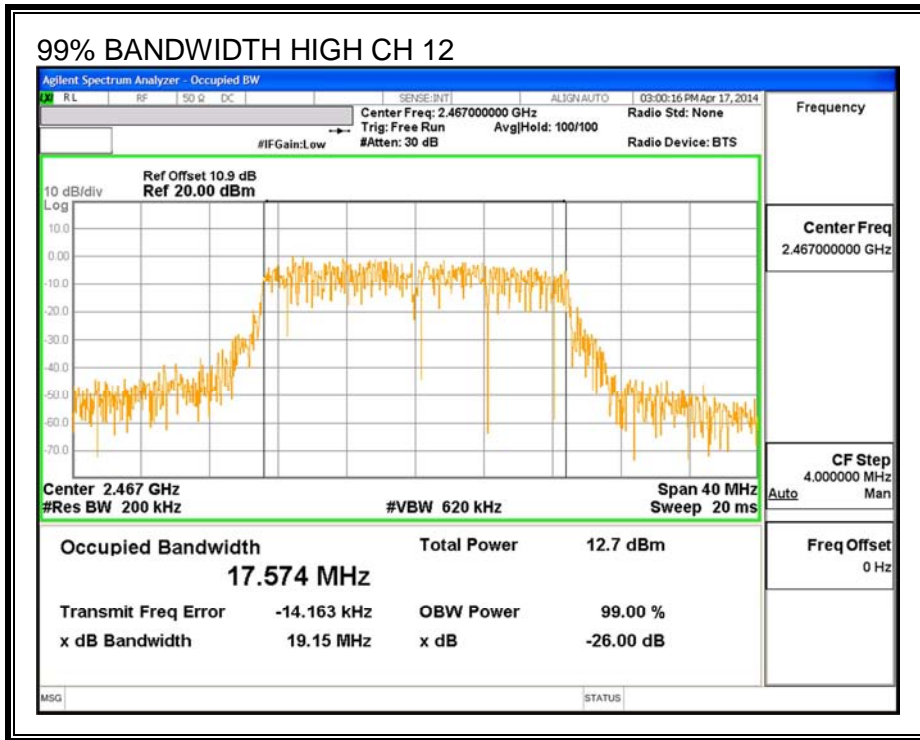
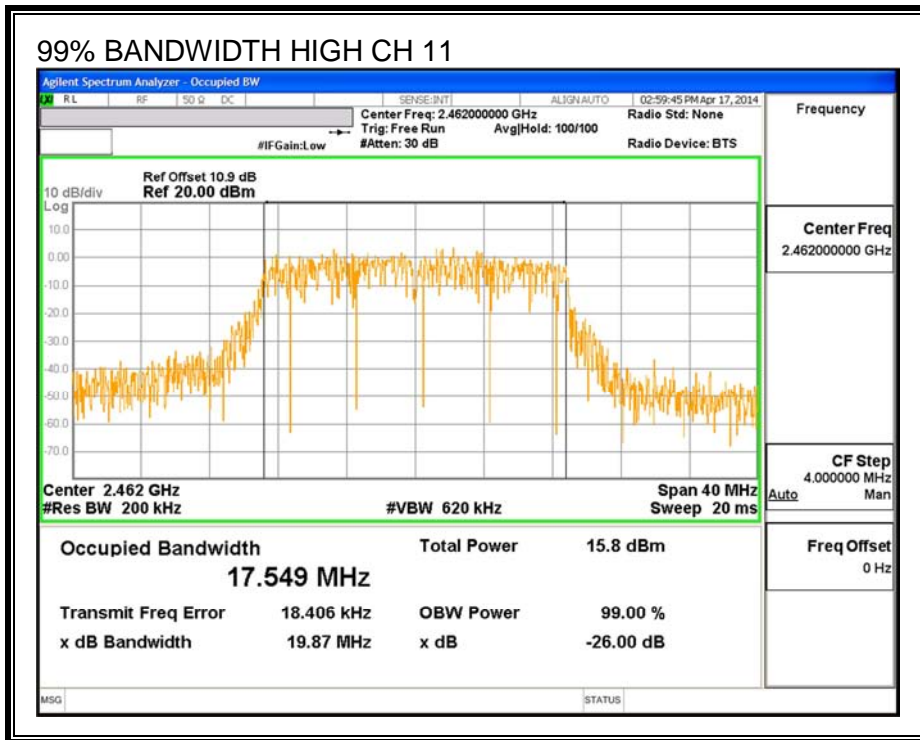

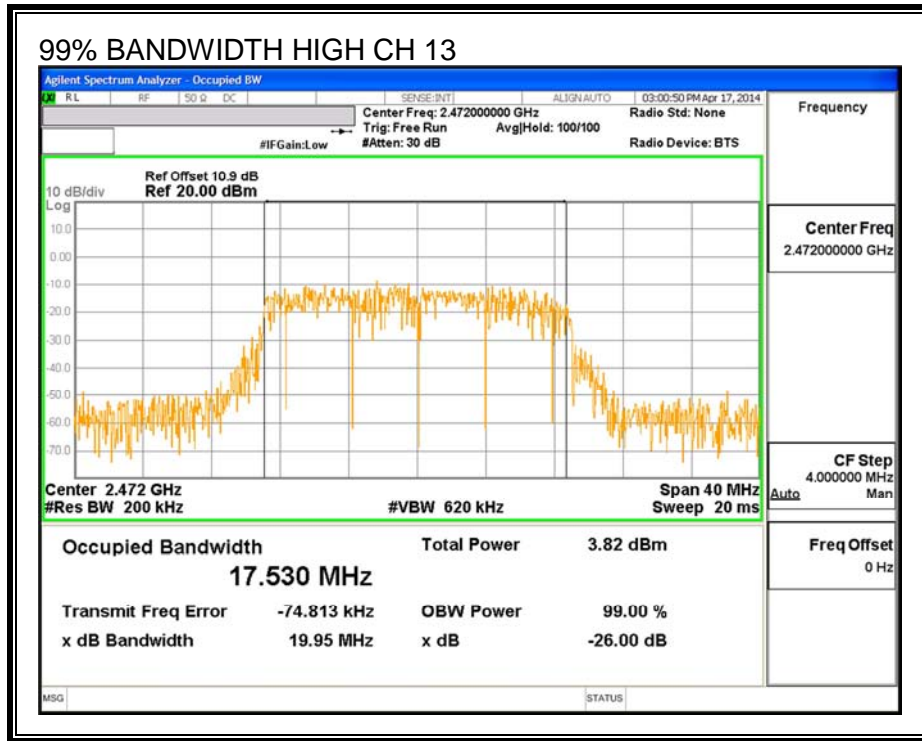

9.3.3. AVERAGE POWER

LIMITS

None; for reporting purposes only.

RESULTS

Channel	Frequency (MHz)	Power (dBm)
1	2412	13.85
2	2417	15.50
3	2422	17.00
6	2437	17.88
11	2462	15.96
12	2467	11.97
13	2472	4.98

9.3.4. OUTPUT POWER

LIMITS

FCC §15.247

For systems using digital modulation in the 2400–2483.5 MHz, and 5725–5850 MHz bands: 1 Watt, based on the use of antennas with directional gains that do not exceed 6dBi. If transmitting antennas of directional gain greater than 6dBi are used, the conducted output power from the intentional radiator shall be reduced by the amount in dB that the directional gain of the antenna exceeds 6dBi.

DIRECTIONAL ANTENNA GAIN

There is only one transmitter output therefore the directional gain is equal to the antenna gain.

RESULTS

Limits

Channel	Frequency (MHz)	Directional Gain (dBi)	FCC Power Limit (dBm)
1	2412	-0.38	30.00
2	2417	-0.38	30.00
3	2422	-0.38	30.00
6	2437	-0.38	30.00
11	2462	-0.38	30.00
12	2467	-0.38	30.00
13	2472	-0.38	30.00

Results

Channel	Frequency (MHz)	Meas Power (dBm)	Total Corr'd Power (dBm)	Power Limit (dBm)	Margin (dB)
1	2412	24.13	24.13	30.00	-5.87
2	2417	24.35	24.35	30.00	-5.65
3	2422	24.63	24.63	30.00	-5.37
6	2437	25.09	25.09	30.00	-4.91
11	2462	24.68	24.68	30.00	-5.32
12	2467	23.20	23.20	30.00	-6.80
13	2472	11.74	11.74	30.00	-18.26

9.3.5. PSD

LIMITS

FCC §15.247 (e)

For digitally modulated systems, the power spectral density conducted from the intentional radiator to the antenna shall not be greater than 8 dBm in any 3 kHz band during any time interval of continuous transmission. This power spectral density shall be determined in accordance with the provisions of paragraph (b) of this section. The same method of determining the conducted output power shall be used to determine the power spectral density.

RESULTS

PSD Results

Channel	Frequency (MHz)	Meas (dBm)	Limit (dBm)	Margin (dB)
1	2412	-6.26	8.0	-14.3
2	2417	-9.51	8.0	-17.5
3	2422	-7.61	8.0	-15.6
6	2437	-7.24	8.0	-15.2
11	2462	-8.36	8.0	-16.4
12	2467	-11.82	8.0	-19.8
13	2472	-20.92	8.0	-28.9

PSD

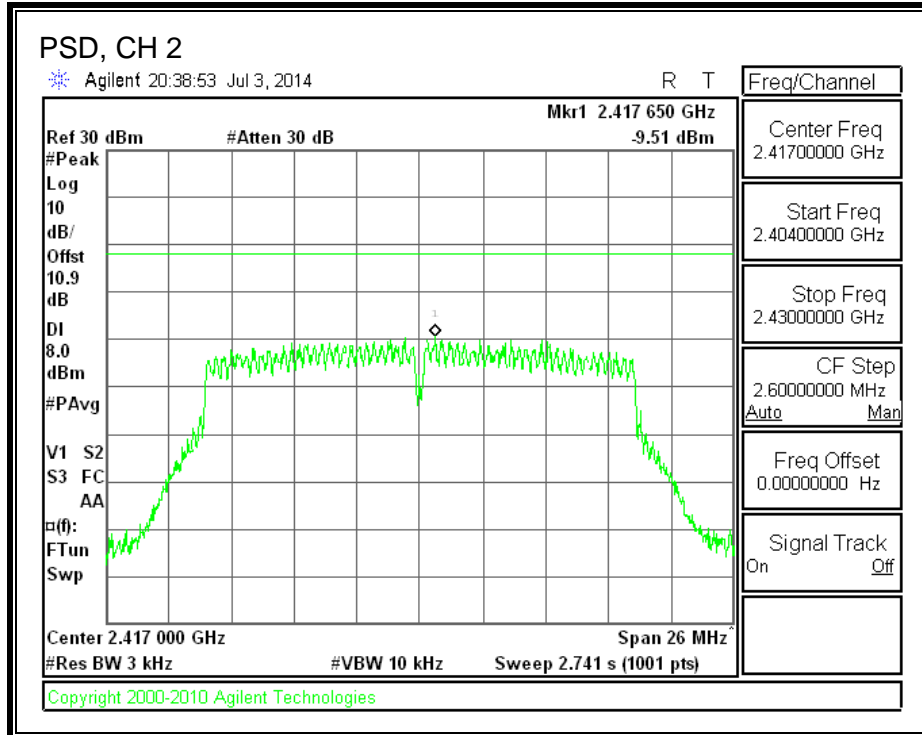
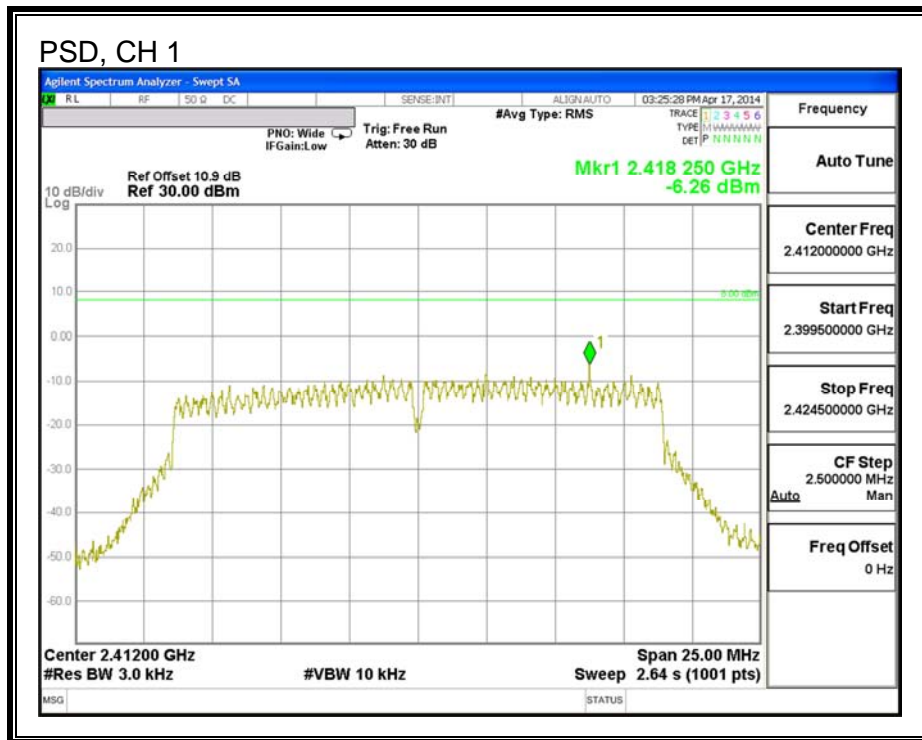

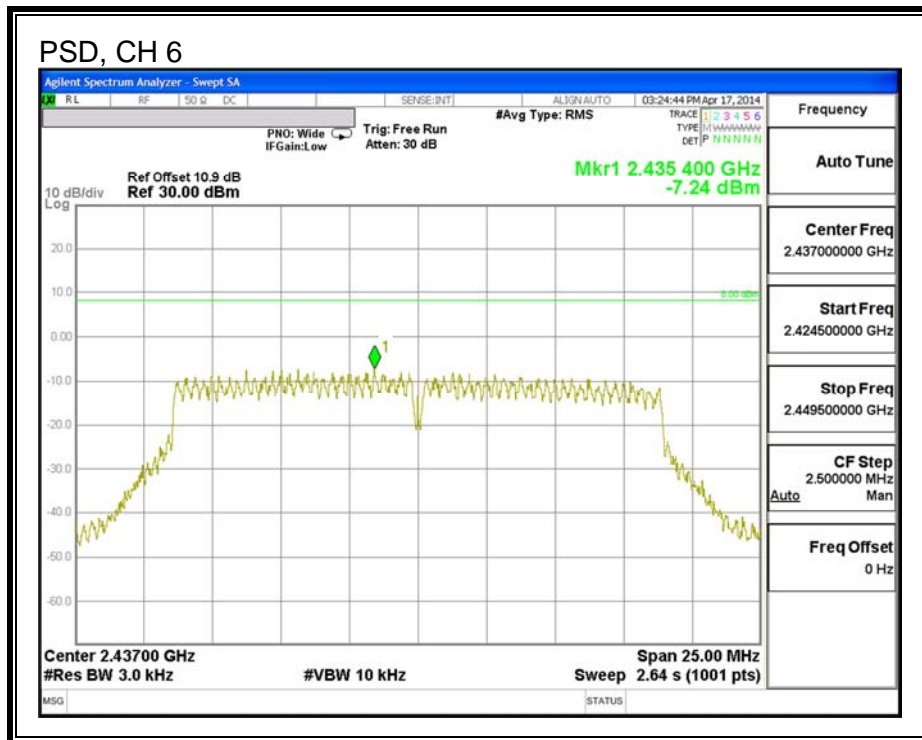
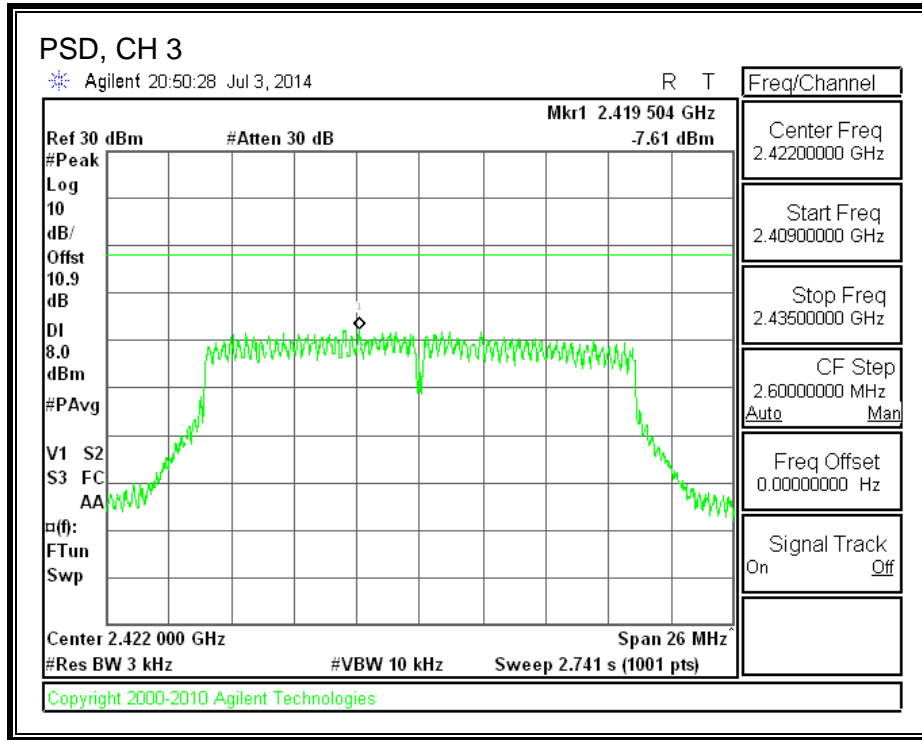

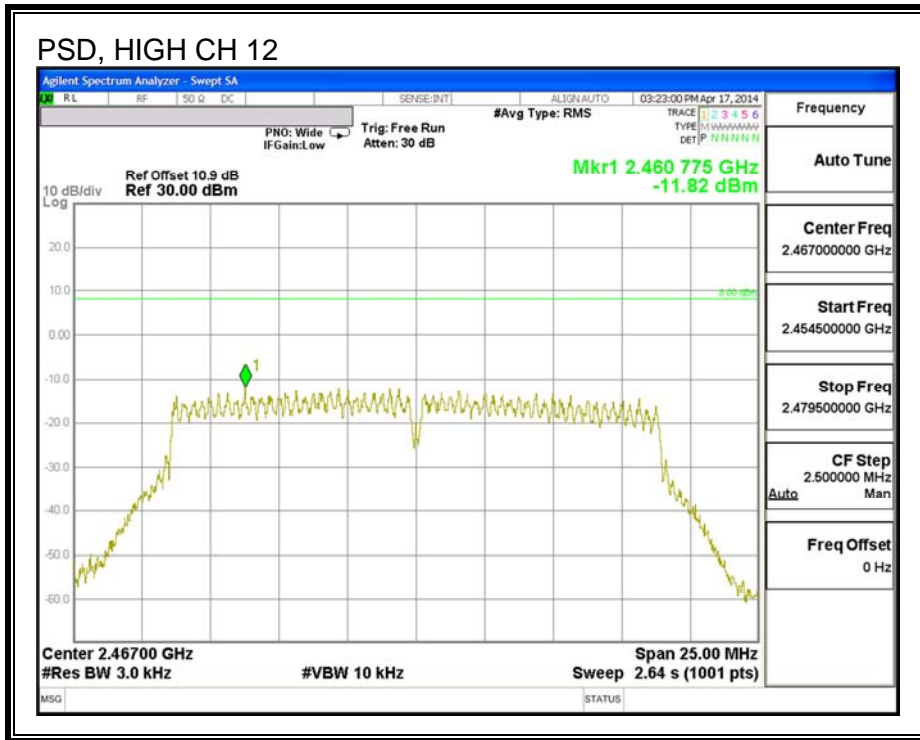
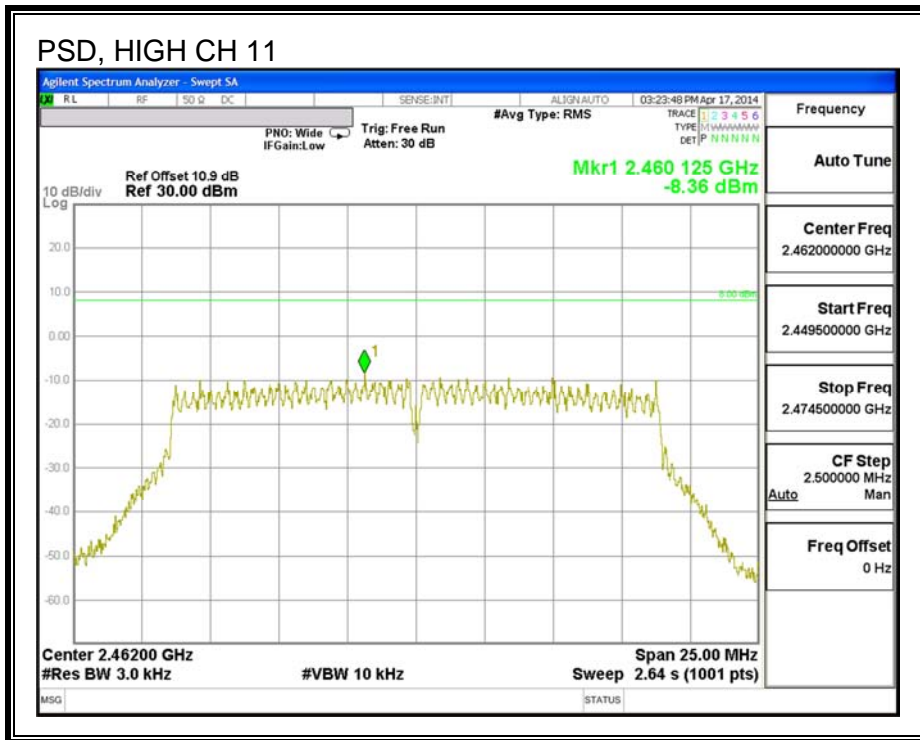

9.3.6. OUT-OF-BAND EMISSIONS

LIMITS

FCC §15.247 (d)

In any 100 kHz bandwidth outside the frequency band in which the spread spectrum or digitally modulated intentional radiator is operating, the radio frequency power that is produced by the intentional radiator shall be at least 20 dB below that in the 100 kHz bandwidth within the band that contains the highest level of the desired power, based on either an RF conducted or a radiated measurement, provided the transmitter demonstrates compliance with the peak conducted power limits. If the transmitter complies with the conducted power limits based on the use of RMS averaging over a time interval, as permitted under paragraph (b)(3) of this section, the attenuation required under this paragraph shall be 30 dB instead of 20 dB. Attenuation below the general limits specified in §15.209(a) is not required.

RESULTS

IN-BAND REFERENCE LEVEL

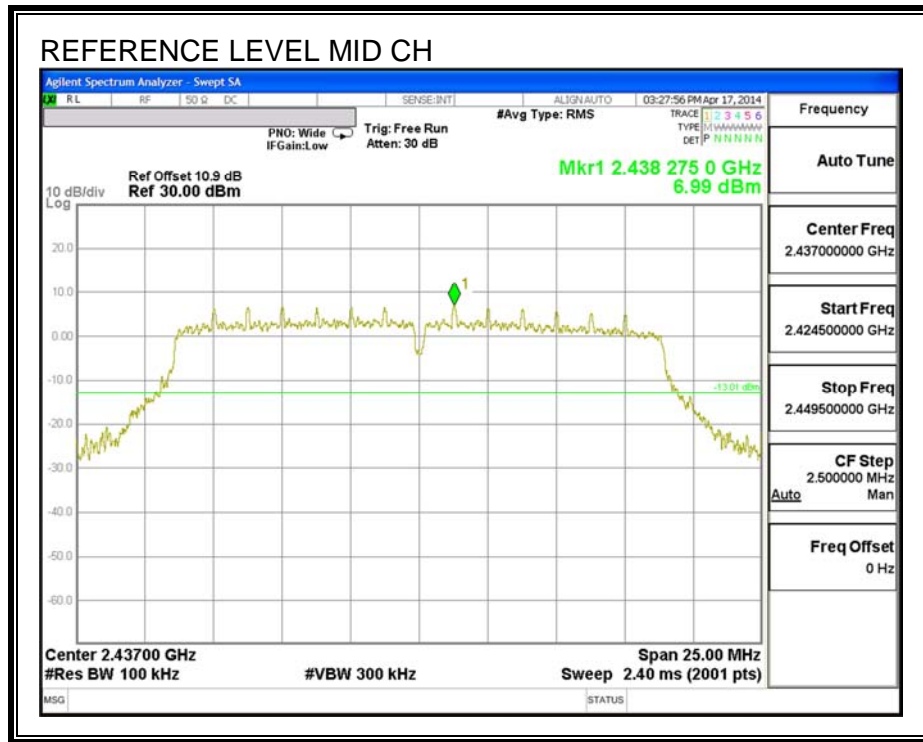

LOW CHANNEL BANDEDGE

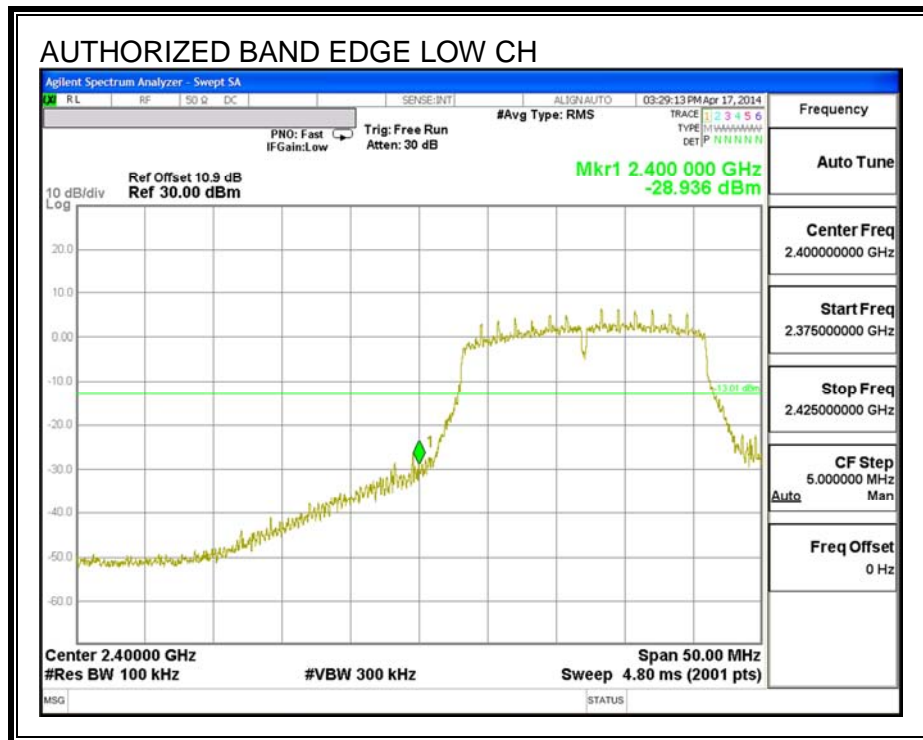

HIGH CHANNEL BANDEDGE

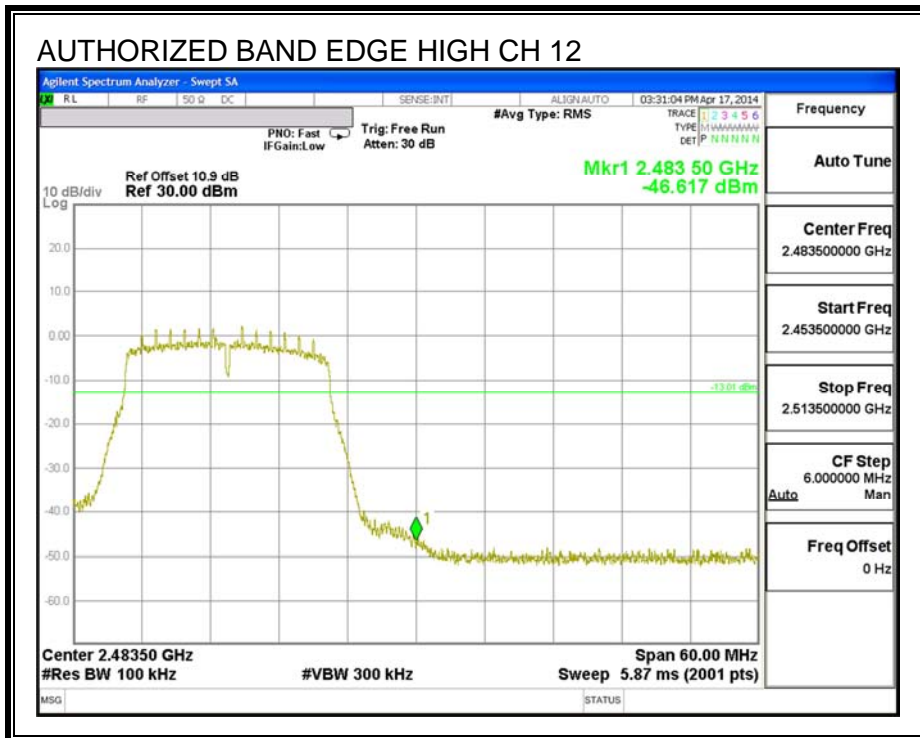
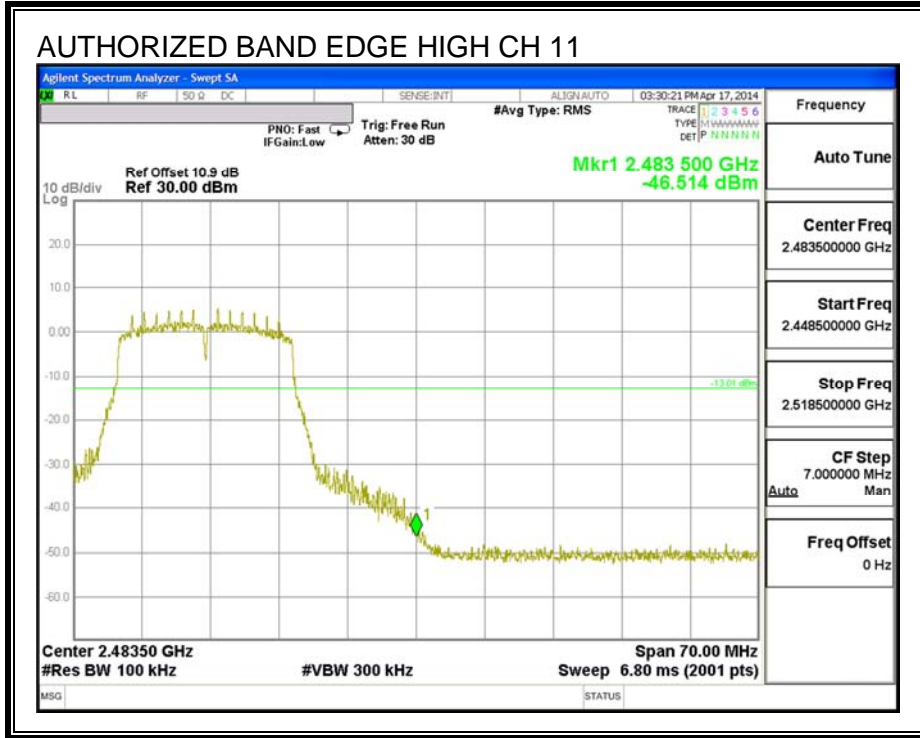

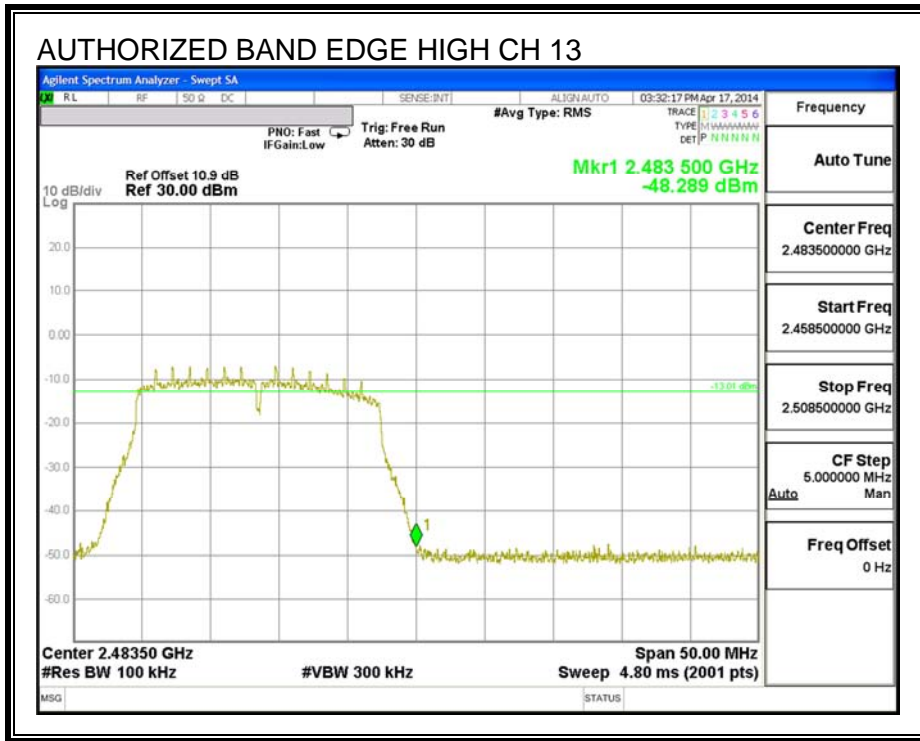

OUT-OF-BAND EMISSIONS

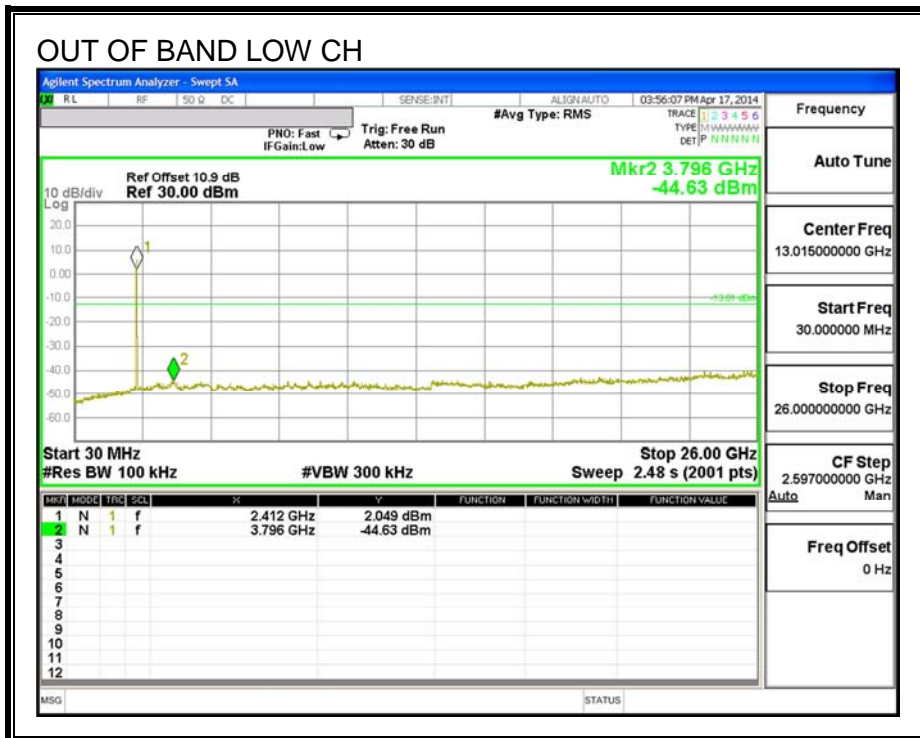

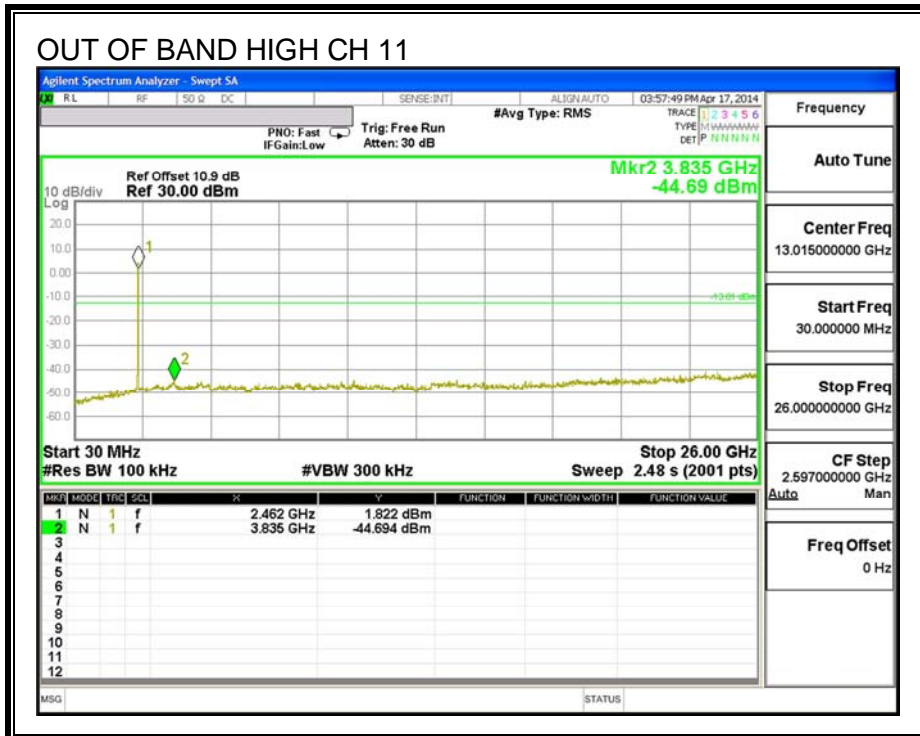
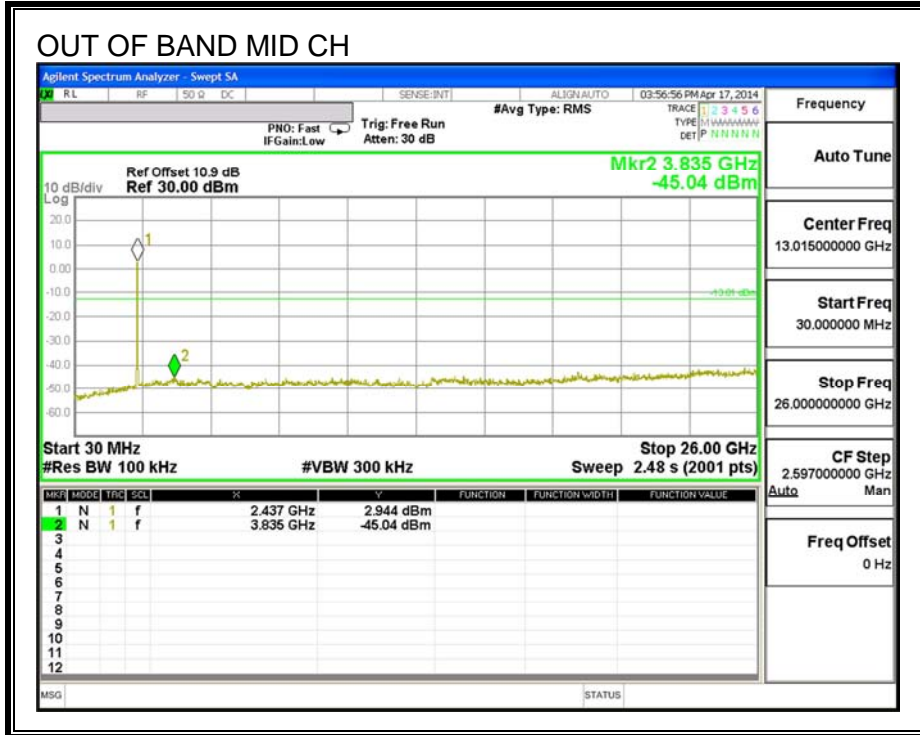

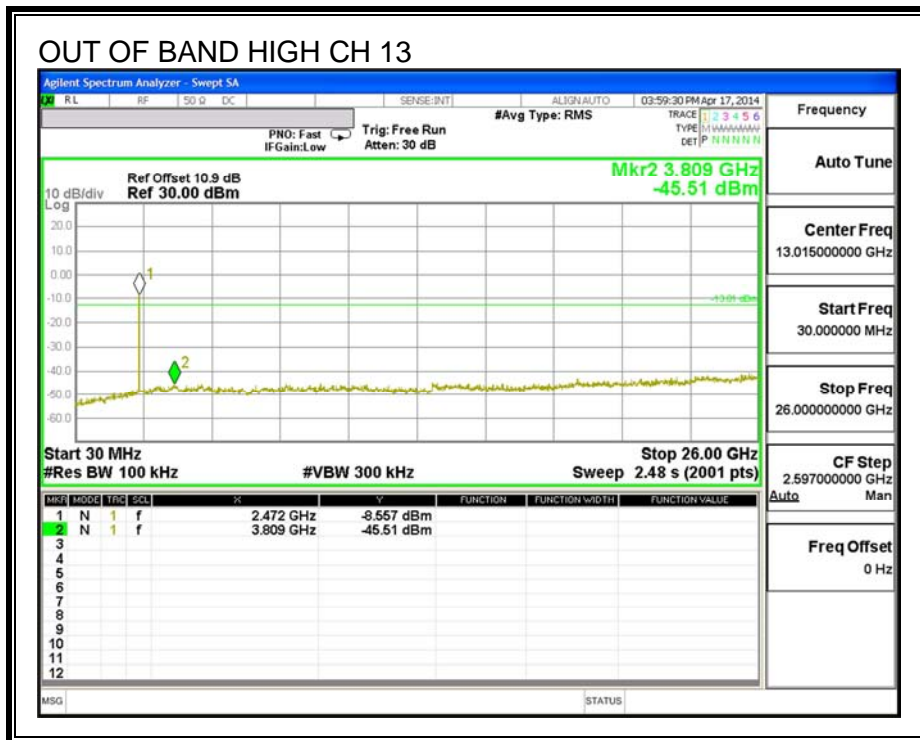
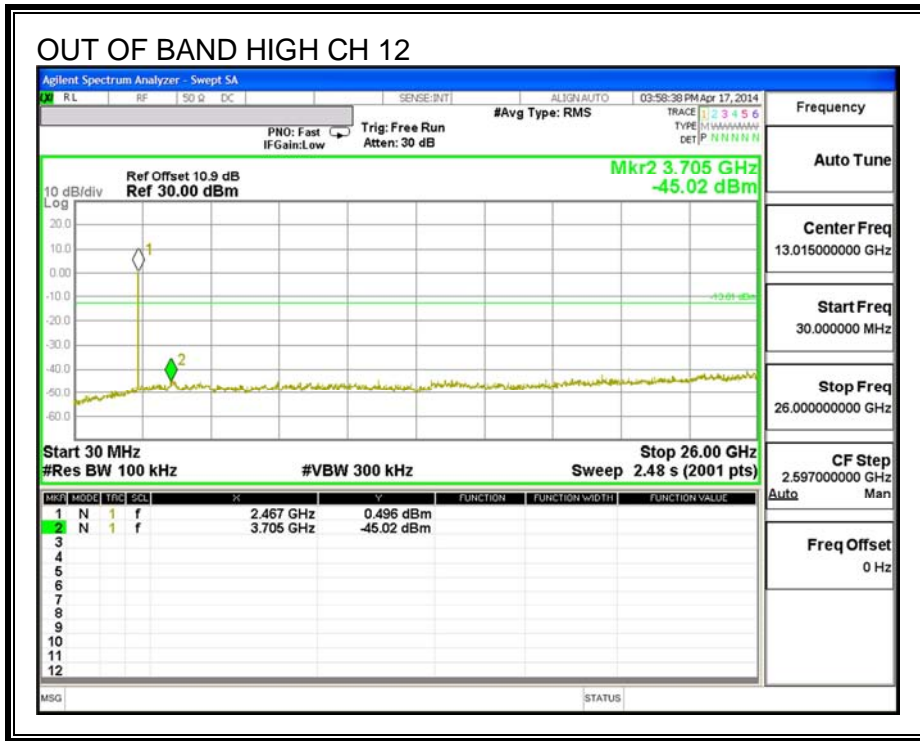

10. RADIATED TEST RESULTS

10.1. LIMITS AND PROCEDURE

LIMITS

FCC §15.205 and §15.209

Frequency Range (MHz)	Field Strength Limit (uV/m) at 3 m	Field Strength Limit (dBuV/m) at 3 m
30 - 88	100	40
88 - 216	150	43.5
216 - 960	200	46
Above 960	500	54

TEST PROCEDURE

The EUT is placed on a non-conducting table 80 cm above the ground plane. The antenna to EUT distance is 3 meters.

For measurements below 1 GHz the resolution bandwidth is set to 100 kHz for peak detection measurements or 120 kHz for quasi-peak detection measurements. Peak detection is used unless otherwise noted as quasi-peak.

For measurements above 1 GHz the resolution bandwidth is set to 1 MHz; the video bandwidth is set to 1 MHz for peak measurements and as applicable for average measurements.

The spectrum from 30 MHz to 40 GHz is investigated with the transmitter set to the lowest, middle, and highest channels in each applicable band.

The frequency range of interest is monitored at a fixed antenna height and EUT azimuth. The EUT is rotated through 360 degrees to maximize emissions received. The antenna is scanned from 1 to 4 meters above the ground plane to further maximize the emission. Measurements are made with the antenna polarized in both the vertical and the horizontal positions.

10.2. TX RADIATED ABOVE 1 GHz

10.2.1.802.11b 1Tx SISO MODE IN THE 2.4 GHz BAND

RESTRICTED BANDEDGE (LOW CHANNEL, CHANNEL 1)

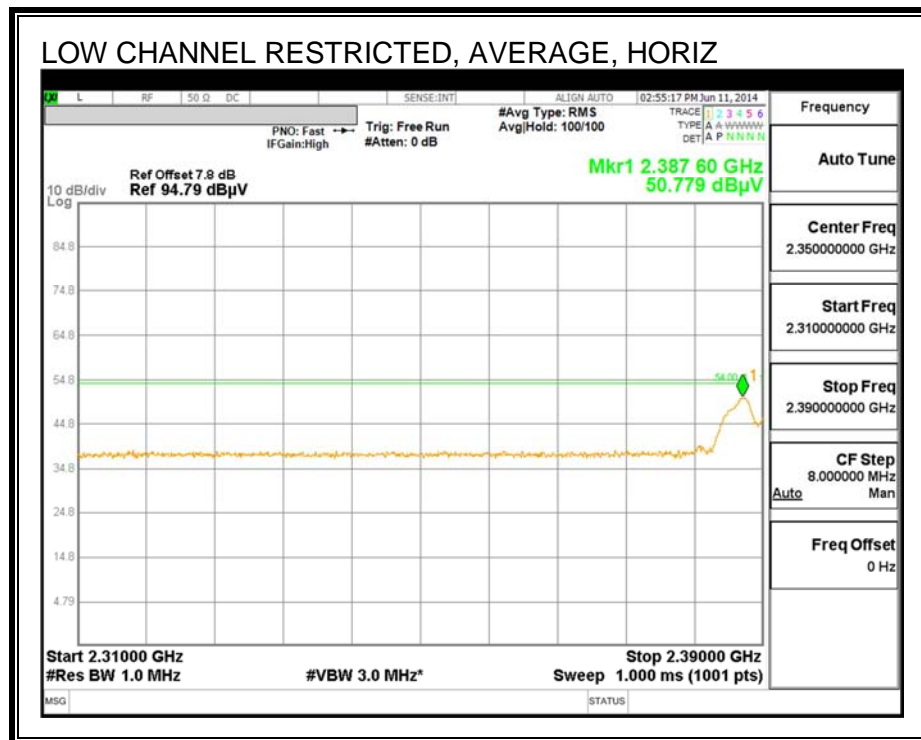
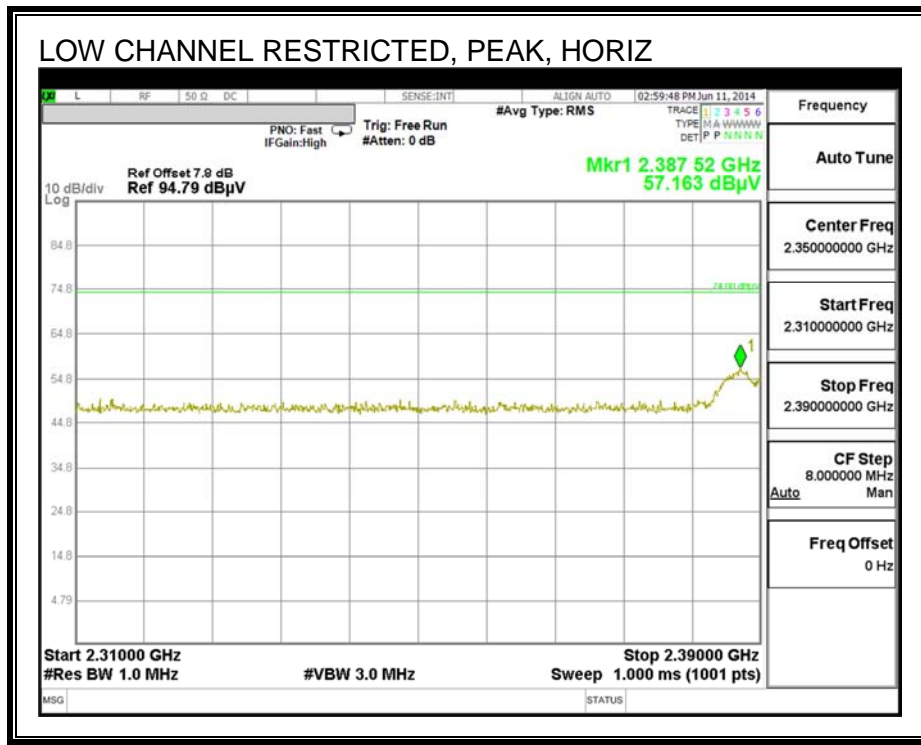

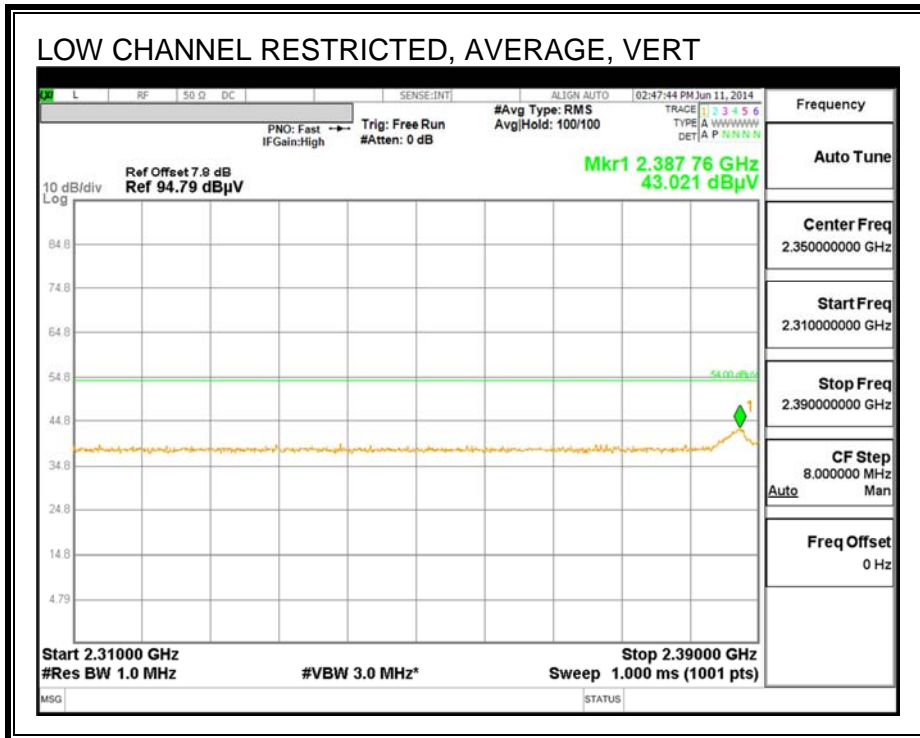
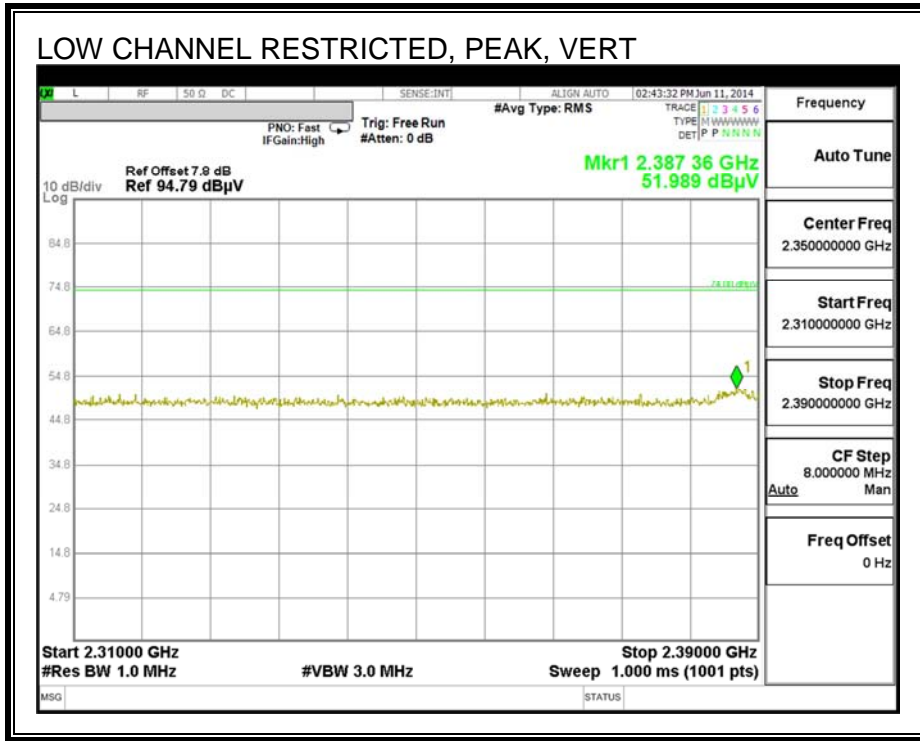

RESTRICTED BANDEDGE (LOW CHANNEL, CHANNEL 2)

