



**FCC CFR47 PART 15 SUBPART C  
INDUSTRY CANADA RSS-210 ISSUE 8**

**CERTIFICATION TEST REPORT**

**Cellular Phone with Bluetooth and WLAN Radios**

**Model: A1549**

**FCC ID: BCG-E2816A  
IC: 579C-E2816A**

**REPORT NUMBER: 14U17673-E4, Revision C**

**ISSUE DATE: AUGUST 02, 2014**

*Prepared for*  
**APPLE, INC.  
1 INFINITE LOOP  
CUPERTINO, CA 95014, U.S.A.**

*Prepared by*  
**UL VERIFICATION SERVICES INC.  
47173 BENICIA STREET  
FREMONT, CA 94538, U.S.A.  
TEL: (510) 771-1000  
FAX: (510) 661-0888**



**NVLAP LAB CODE 200065-0**

Revision History

<u>Rev.</u>	<u>Issue Date</u>	<u>Revisions</u>	<u>Revised By</u>
--	7/17/14	Initial Issue	F. deAnda
A	7/23/14	Update Product Description	M. Hua
B	7/29/14	Update: to referenced reports	F. deAnda
C	08/02/14	Address TCB Questions	T. Lee

## TABLE OF CONTENTS

<b>1. ATTESTATION OF TEST RESULTS .....</b>	<b>4</b>
<b>2. TEST METHODOLOGY .....</b>	<b>5</b>
<b>5. EQUIPMENT UNDER TEST .....</b>	<b>7</b>
5.1. <i>DESCRIPTION OF EUT .....</i>	7
5.2. <i>MAXIMUM OUTPUT POWER .....</i>	7
5.3. <i>DESCRIPTION OF AVAILABLE ANTENNAS .....</i>	7
5.4. <i>SOFTWARE AND FIRMWARE.....</i>	7
5.5. <i>WORST-CASE CONFIGURATION AND MODE.....</i>	7
5.6. <i>DESCRIPTION OF TEST SETUP.....</i>	8
<b>6. TEST AND MEASUREMENT EQUIPMENT .....</b>	<b>12</b>
<b>7. MEASUREMENT METHODS .....</b>	<b>13</b>
<b>8. ON TIME, DUTY CYCLE AND MEASUREMENT METHODS .....</b>	<b>13</b>
8.1. <i>ON TIME AND DUTY CYCLE RESULTS.....</i>	13
<b>9. ANTENNA PORT TEST RESULTS .....</b>	<b>13</b>
<b>10. RADIATED TEST RESULTS.....</b>	<b>14</b>
10.1. <i>TRANSMITTER ABOVE 1 GHz.....</i>	15
10.2. <i>WORST-CASE ABOVE 18 GHz.....</i>	25
10.3. <i>WORST-CASE BELOW 1 GHz.....</i>	26
<b>11. AC POWER LINE CONDUCTED EMISSIONS.....</b>	<b>29</b>
<b>12. SETUP PHOTOS.....</b>	<b>33</b>

# 1. ATTESTATION OF TEST RESULTS

**COMPANY NAME:** APPLE, INC.  
1 INFINITE LOOP  
CUPERTINO, CA 95014, U.S.A.

**EUT DESCRIPTION:** Cellular Phone with Bluetooth and WLAN Radio

**MODEL:** A1549

**SERIAL NUMBER:** C39MD06FFY70 – Radiated

**DATE TESTED:** APRIL 23, 2014 - JUNE 10, 2014

APPLICABLE STANDARDS	
STANDARD	TEST RESULTS
CFR 47 Part 15 Subpart C	Pass
INDUSTRY CANADA RSS-210 Issue 8 Annex 8	Pass
INDUSTRY CANADA RSS-GEN Issue 3	Pass

UL Verification Services Inc. tested the above equipment in accordance with the requirements set forth in the above standards. All indications of Pass/Fail in this report are opinions expressed by UL Verification Services based on interpretations and/or observations of test results. Measurement Uncertainties were not taken into account and are published for informational purposes only. The test results show that the equipment tested is capable of demonstrating compliance with the requirements as documented in this report.

**Note:** The results documented in this report apply only to the tested sample, under the conditions and modes of operation as described herein. This document may not be altered or revised in any way unless done so by UL Verification Services and all revisions are duly noted in the revisions section. Any alteration of this document not carried out by UL Verification Services will constitute fraud and shall nullify the document. This report must not be used by the client to claim product certification, approval, or endorsement by NVLAP, NIST, any agency of the Federal Government, or any agency of any government.

Approved & Released For  
UL Verification Services Inc. By:

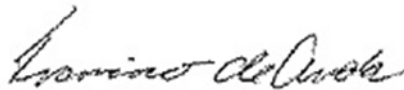

Francisco de Anda  
Project Lead  
UL Verification Services Inc.

Tested By:

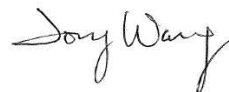

TONY WANG  
Lab Engineer  
UL Verification Services Inc

## 2. TEST METHODOLOGY

The tests documented in this report were performed in accordance with ANSI C63.10-2009, FCC CFR 47 Part 2, FCC CFR 47 Part 15, RSS-GEN Issue 3, and RSS-210 Issue 8.

Per FCC guidance, radiated tests are performed for A1549 to ensure that there is no deviation in EM fields between Model A1549 and Model A1586.

## 3. FACILITIES AND ACCREDITATION

The test sites and measurement facilities used to collect data are located at 47173 and 47266 Benicia Street, Fremont, California, USA. Line conducted emissions are measured only at the 47173 address. The following table identifies which facilities were utilized for radiated emission measurements documented in this report. Specific facilities are also identified in the test results sections.

47173 Benicia Street	47266 Benicia Street
<input type="checkbox"/> Chamber A	<input type="checkbox"/> Chamber D
<input type="checkbox"/> Chamber B	<input checked="" type="checkbox"/> Chamber E
<input type="checkbox"/> Chamber C	<input checked="" type="checkbox"/> Chamber F

UL Verification Services Inc. is accredited by NVLAP, Laboratory Code 200065-0. The full scope of accreditation can be viewed at <http://ts.nist.gov/standards/scopes/2000650.htm>

## 4. CALIBRATION AND UNCERTAINTY

### 4.1. MEASURING INSTRUMENT CALIBRATION

The measuring equipment utilized to perform the tests documented in this report has been calibrated in accordance with the manufacturer's recommendations, and is traceable to recognized national standards.

### 4.2. SAMPLE CALCULATION

Where relevant, the following sample calculation is provided:

$$\begin{aligned} \text{Field Strength (dBuV/m)} &= \text{Measured Voltage (dBuV)} + \text{Antenna Factor (dB/m)} + \\ &\text{Cable Loss (dB)} - \text{Preamp Gain (dB)} \\ 36.5 \text{ dBuV} + 18.7 \text{ dB/m} + 0.6 \text{ dB} - 26.9 \text{ dB} &= 28.9 \text{ dBuV/m} \end{aligned}$$

### 4.3. MEASUREMENT UNCERTAINTY

Where relevant, the following measurement uncertainty levels have been estimated for tests performed on the apparatus:

PARAMETER	UNCERTAINTY
Conducted Disturbance, 0.15 to 30 MHz	3.52 dB
Radiated Disturbance, 30 to 1000 MHz	4.94 dB

Uncertainty figures are valid to a confidence level of 95%.

## 5. EQUIPMENT UNDER TEST

### 5.1. DESCRIPTION OF EUT

Model A1549 is a mobile phone with multimedia functions (music, application support, and video), Cellular GSM/GPRS/EGPRS/CDMA2000/EVDO Rev.A/ EVDO Rev.B /WCDMA/HSPA+/DC-HSDPA/LTE FDD & Carrier Aggregation radio, IEEE 802.11a/b/g/n/ac radio, Bluetooth radio and NFC. The rechargeable battery is not user accessible.

### 5.2. MAXIMUM OUTPUT POWER

For Maximum output power, refer to Model A1586 BLE report.

### 5.3. DESCRIPTION OF AVAILABLE ANTENNAS

The radio utilizes a PiFA antenna, with a maximum gain of  $-38\text{dBi}$

### 5.4. SOFTWARE AND FIRMWARE

The test utility software used during testing was Bluetool 1.8.5

### 5.5. WORST-CASE CONFIGURATION AND MODE

The worst-case mode and channel used for 30-1000 MHz radiated and power line conducted emissions was including headset, AC charger and the mode and channel with the highest output power.

The EUT is a portable device that has three orientations; therefore X, Y and Z orientations have been investigated with AC adapter and Headset, and the worst case was found to be at X (Flatbed) position without AC adapter and headset.

There are three vendors of the WiFi/Bluetooth radio modules: variant 1, variant 2 and variant 3 and they have the same mechanical outline, same on board antenna, matching circuit, antenna structure and same specification. Baseline testing was performed on all three variants to determine the worst case on all conducted power and radiated emissions.

## 5.6. DESCRIPTION OF TEST SETUP

### SUPPORT EQUIPMENT

Support Equipment List				
Description	Manufacturer	Model	Serial Number	FCC ID
AC/DC adapter	Apple	A1401	60812	NA
Earphone	Apple	NA	NA	NA
Laptop	Apple	A1278	C02HJ0A7DTY4	NA

### I/O CABLES (CONDUCTED TEST)

I/O Cable List						
Cable No	Port	# of identical ports	Connector Type	Cable Type	Cable Length (m)	Remarks
1	Antenna	1	SMA	Un-Shielded	0.1	to spectrum Analyzer
2	USB	1	USB	Shielded	1m	To EUT

### I/O CABLES (RADIATED ABOVE 1 GHZ)

I/O Cable List						
Cable No	Port	# of identical ports	Connector Type	Cable Type	Cable Length (m)	Remarks
one used						

### I/O CABLES (BELOW 1GHZ & AC LINE CONDUCTED TESTS)

I/O Cable List						
Cable No	Port	# of identical ports	Connector Type	Cable Type	Cable Length (m)	Remarks
1	AC	1	US115	Un-Shielded	80cm	NA
2	DC	1	USB	Un-Shielded	1m	NA
3	Audio	1	Jack	Un-Shielded	0.5m	NA



**TEST SETUP- CONDUCTED PORT**

The EUT was tested connected to a host Laptop via USB cable adapter and spectrum analyzer to antenna port. Test software exercised the EUT.

**SETUP DIAGRAM**

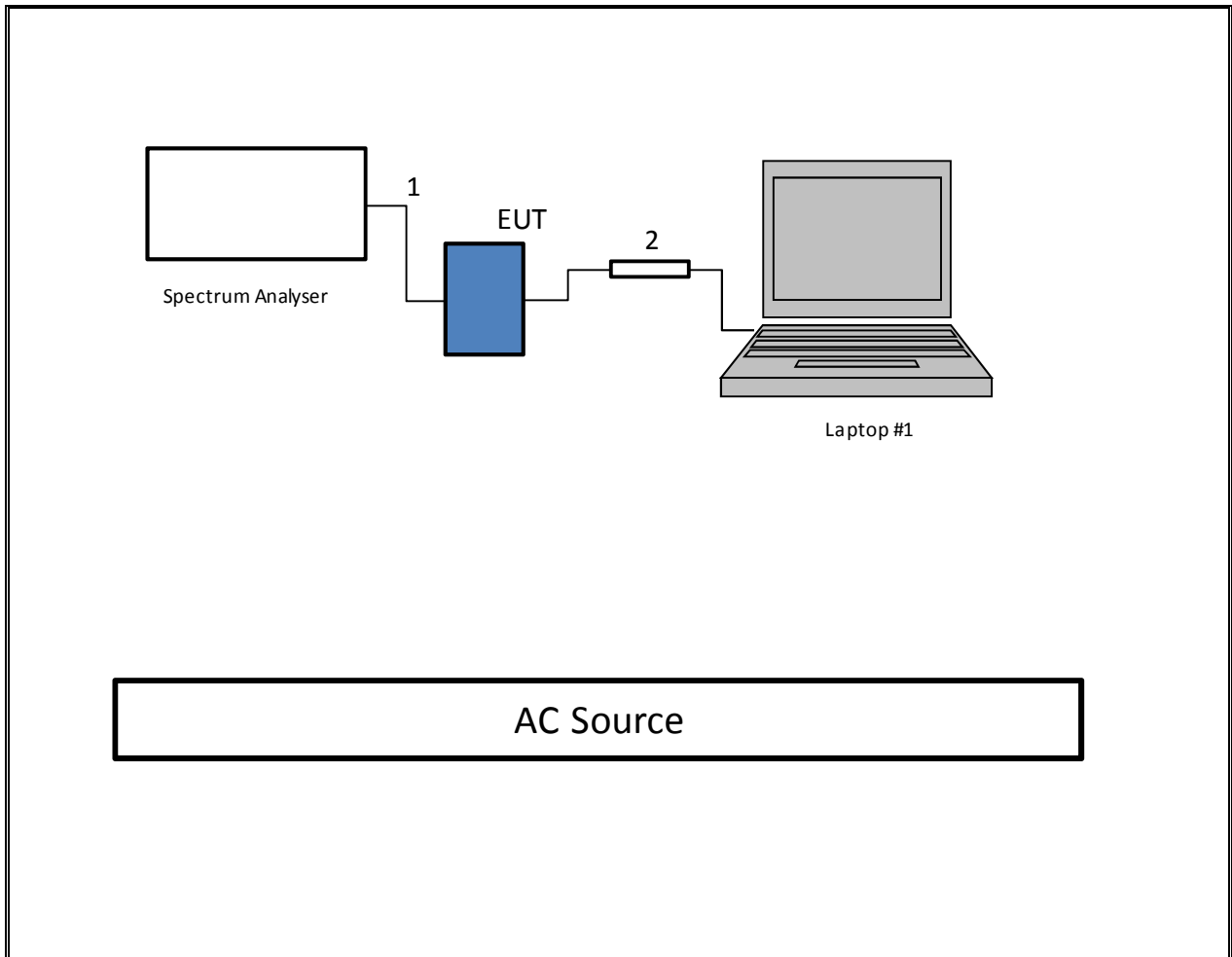

**TEST SETUP- RADIATED-ABOVE 1 GHZ**

The EUT was tested battery powered. Test software exercised the EUT.

**SETUP DIAGRAM**

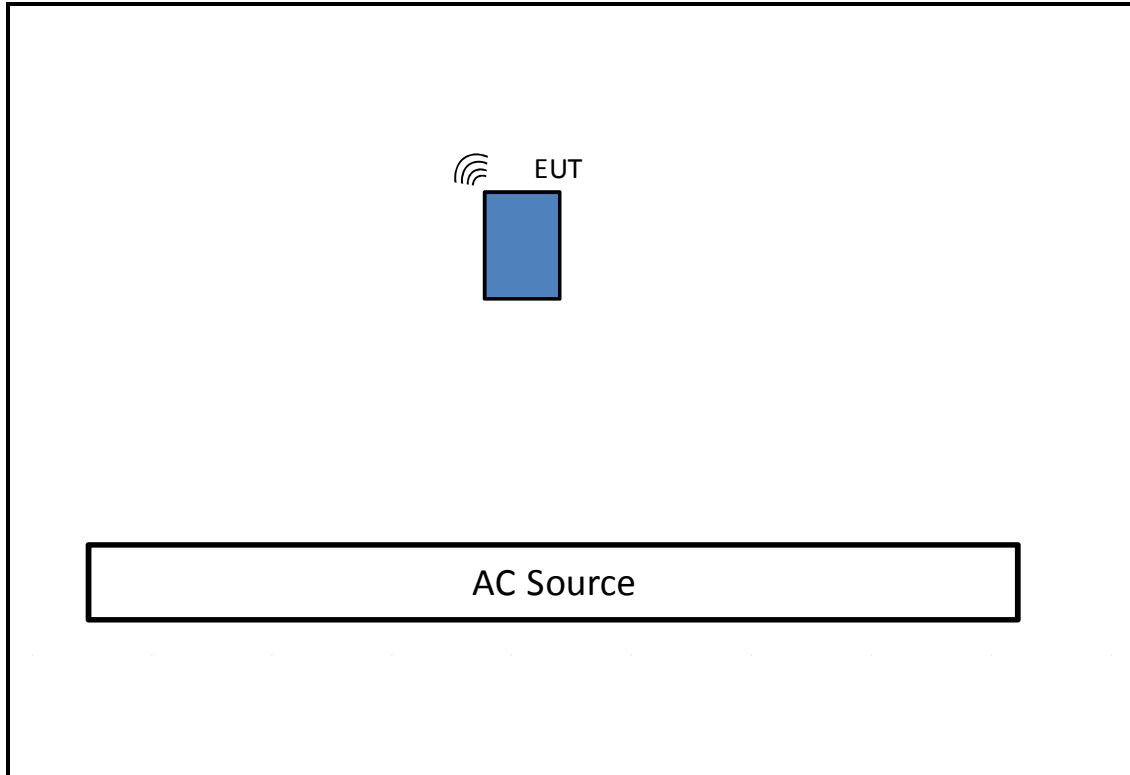

**TEST SETUP- BELOW 1GHZ & AC LINE CONDUCTED TESTS**

The EUT was tested with earphones connected and powered by AC adapter. Test software exercised the EUT.

**SETUP DIAGRAM**

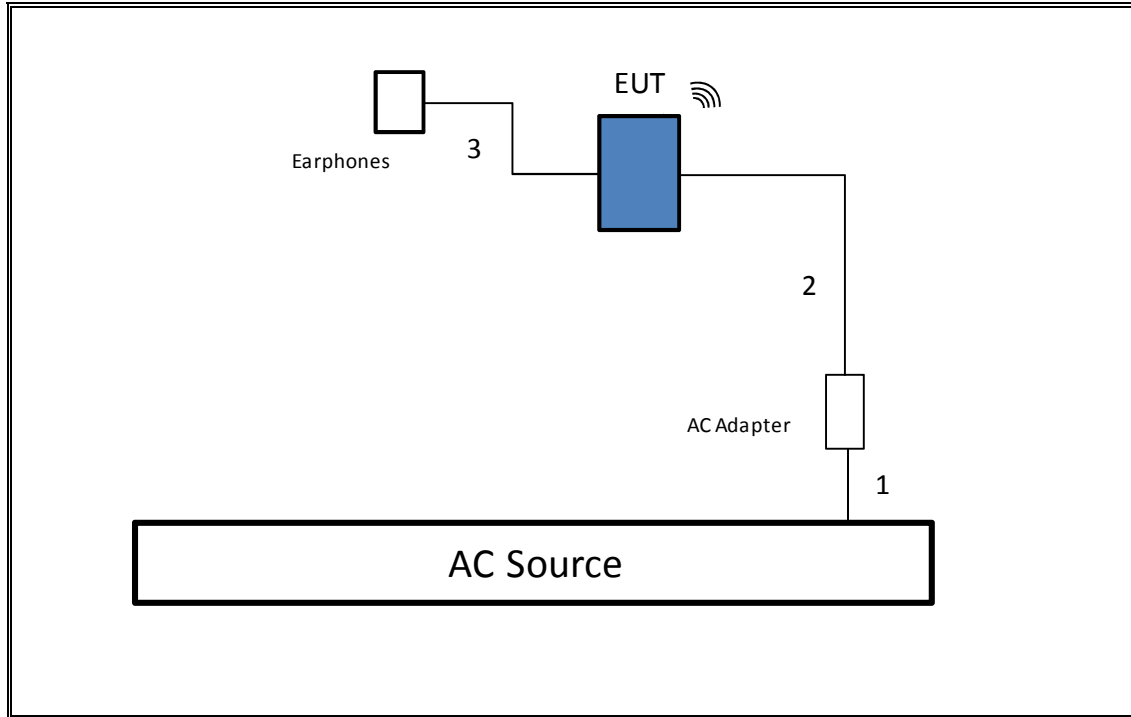

## 6. TEST AND MEASUREMENT EQUIPMENT

The following test and measurement equipment was utilized for the tests documented in this report:

TEST EQUIPMENT LIST				
Description	Manufacturer	Model	Asset	Cal Due
Antenna, Horn, 18 GHz	ETS Lindgren	3117	F00131	02/18/15
Antenna, Horn, 26.5 GHz	ARA	MVH-1826/B	C00589	11/26/14
Antenna, Horn, 40 GHz	ARA	MVH-2640	C00981	06/28/14
Peak / Average Power Sensor	Agilent / HP	N1911A	F00153	03/06/15
Wideband Power Sensor	Agilent	N1921A	F00361	10/02/14
Peak Power Meter	Agilent / HP	E9323A	F00025	04/03/15
Spectrum Analyzer, 44 GHz	Agilent / HP	N9030A	F00129	02/22/15
Spectrum Analyzer, 40 GHz	Agilent	8564E	C00951	07/29/14
Antenna, Bilog, 2 GHz	Sundt Sciences	JB1	F00168	03/28/15
Preamplifier, 1300 MHz	Sonoma	310	F00008	05/27/15
Preamplifier, 26.5 GHz	Agilent / HP	8449B	F00165	03/25/15

## 7. MEASUREMENT METHODS

6 dB BW: KDB 558074 D01.

Output Power: KDB 558074 D01.

Power Spectral Density: KDB 558074 D01.

Out-of-band emissions in non-restricted bands: KDB 558074 D01.

Out-of-band emissions in restricted bands: KDB 558074 D01.

## 8. ON TIME, DUTY CYCLE AND MEASUREMENT METHODS

### LIMITS

None; for reporting purposes only.

### PROCEDURE

KDB 789033 Zero-Span Spectrum Analyzer Method.

### 8.1. ON TIME AND DUTY CYCLE RESULTS

For on time and duty cycle data, refer to Model A1586 BLE report.

## 9. ANTENNA PORT TEST RESULTS

For antenna port data, refer to Model A1586 BLE report.

## 10. RADIATED TEST RESULTS

### LIMITS AND PROCEDURE

#### LIMITS

FCC §15.205 and §15.209

IC RSS-210 Clause 2.6 (Transmitter)

IC RSS-GEN Clause 6 (Receiver)

Frequency Range (MHz)	Field Strength Limit (uV/m) at 3 m	Field Strength Limit (dBuV/m) at 3 m
30 - 88	100	40
88 - 216	150	43.5
216 - 960	200	46
Above 960	500	54

#### TEST PROCEDURE

The EUT is placed on a non-conducting table 80 cm above the ground plane. The antenna to EUT distance is 3 meters. The EUT is configured in accordance with ANSI C63.4. The EUT is set to transmit in a continuous mode.

For measurements below 1 GHz the resolution bandwidth is set to 100 kHz for peak detection measurements or 120 kHz for quasi-peak detection measurements. Peak detection is used unless otherwise noted as quasi-peak.

For measurements above 1 GHz the resolution bandwidth is set to 1 MHz, then the video bandwidth is set to 1 MHz for peak measurements and 10 Hz for average measurements.

For 2.4 GHz band, the spectrum from 30 MHz to 26 GHz is investigated with the transmitter set to the lowest, middle, and highest channels in the 2.4 GHz band.

The frequency range of interest is monitored at a fixed antenna height and EUT azimuth. The EUT is rotated through 360 degrees to maximize emissions received. The antenna is scanned from 1 to 4 meters above the ground plane to further maximize the emission. Measurements are made with the antenna polarized in both the vertical and the horizontal positions.

Per FCC guidance, radiated tests are performed to ensure there is no deviation in EM fields between Model A1549 and Model A1586.

### 10.1. TRANSMITTER ABOVE 1 GHz

#### RESTRICTED BANDEDGE (LOW CHANNEL, HORIZONTAL)

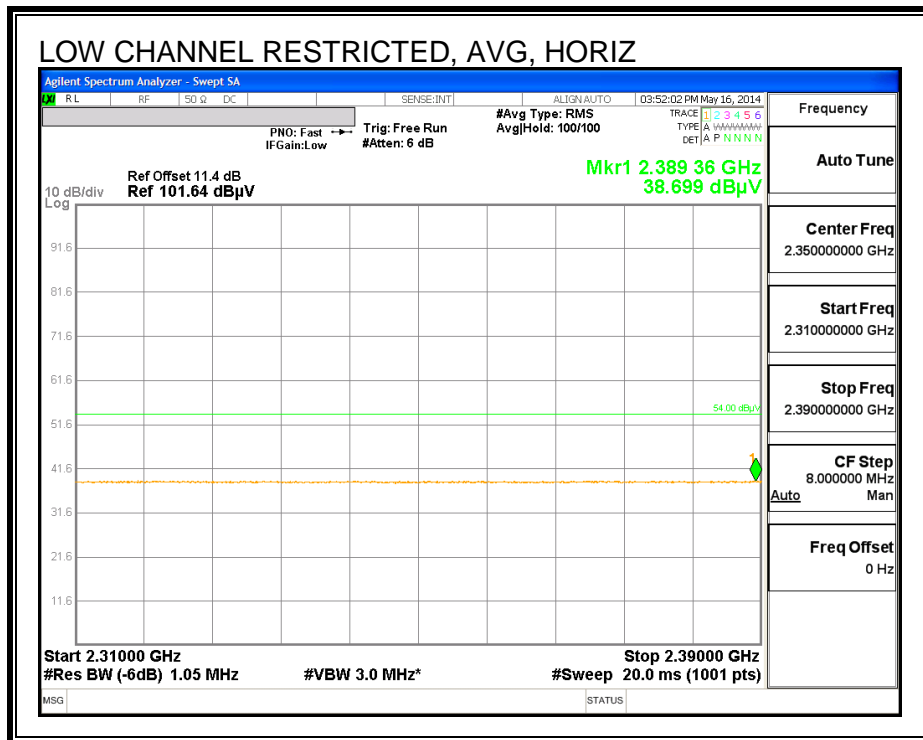
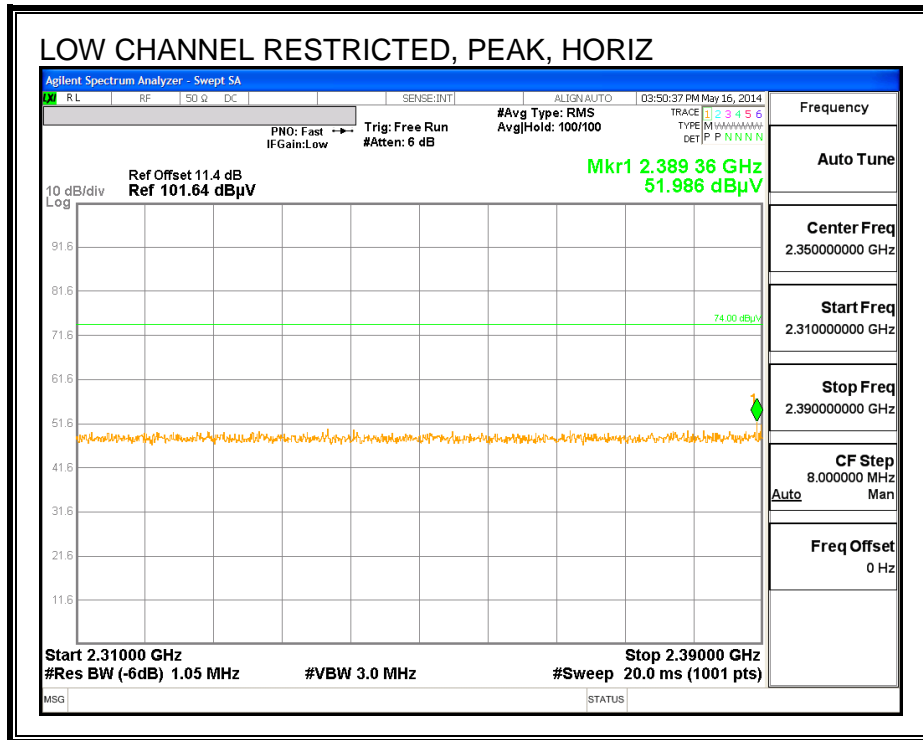





**RESTRICTED BANDEDGE (HIGH CHANNEL, HORIZONTAL)**

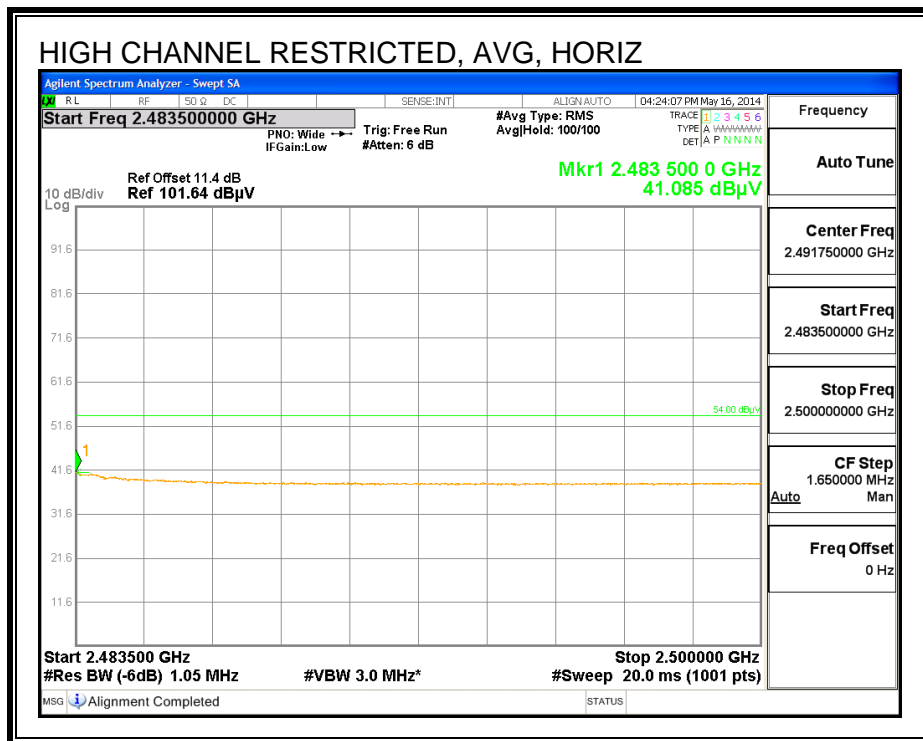
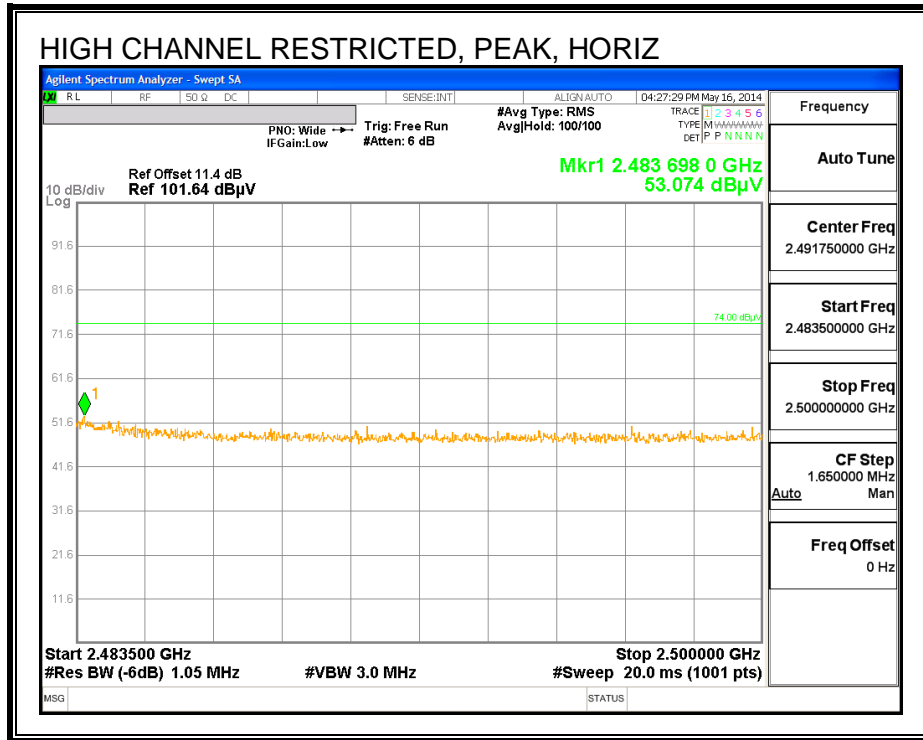

**RESTRICTED BANDEDGE (HIGH CHANNEL, VERTICAL)**

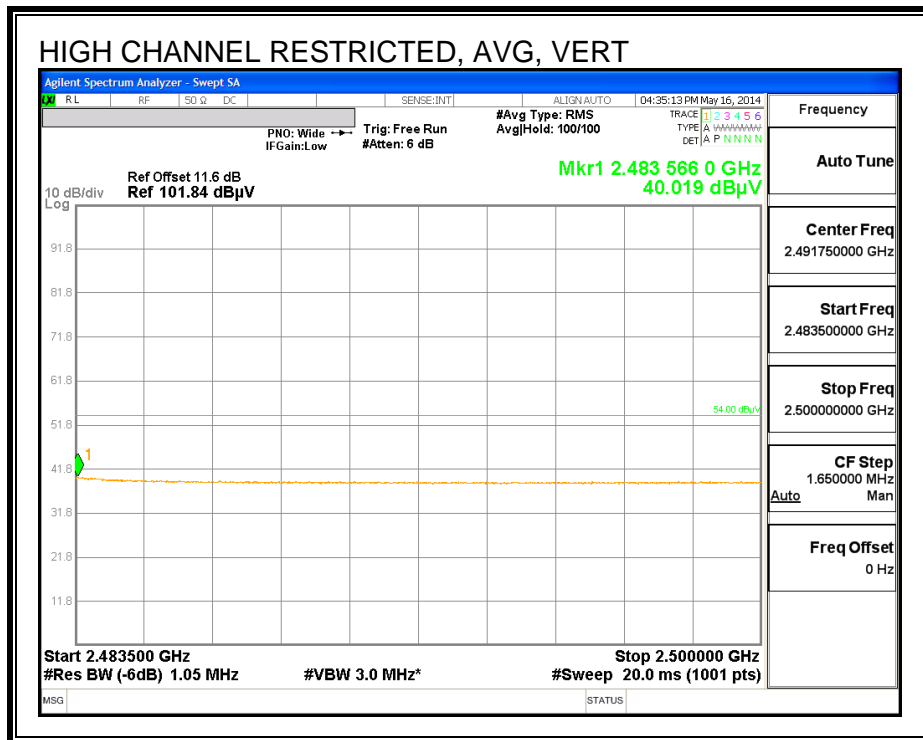
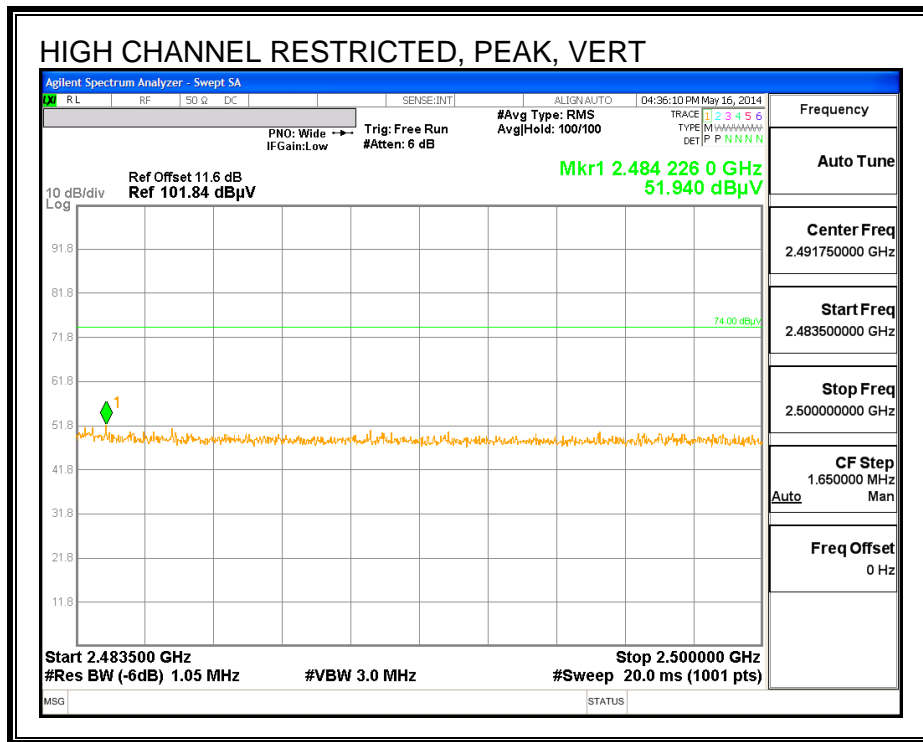

**LOW CHANNEL HARMONICS AND SPURIOUS**

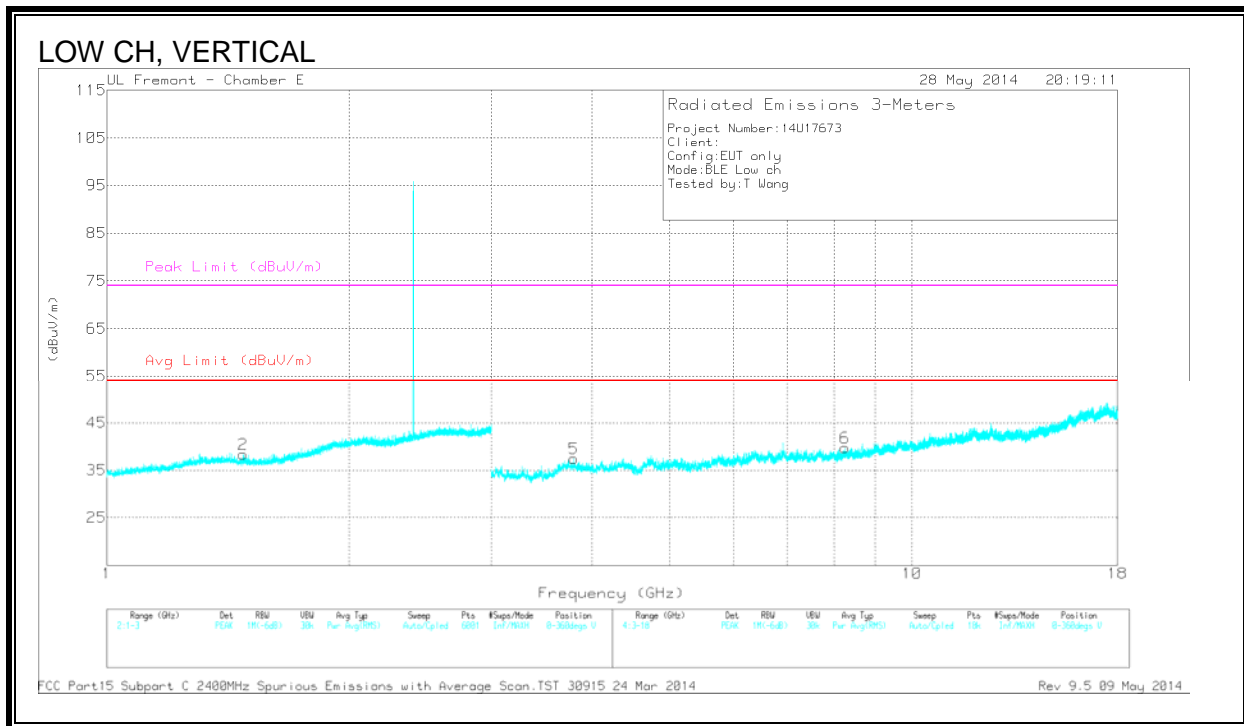
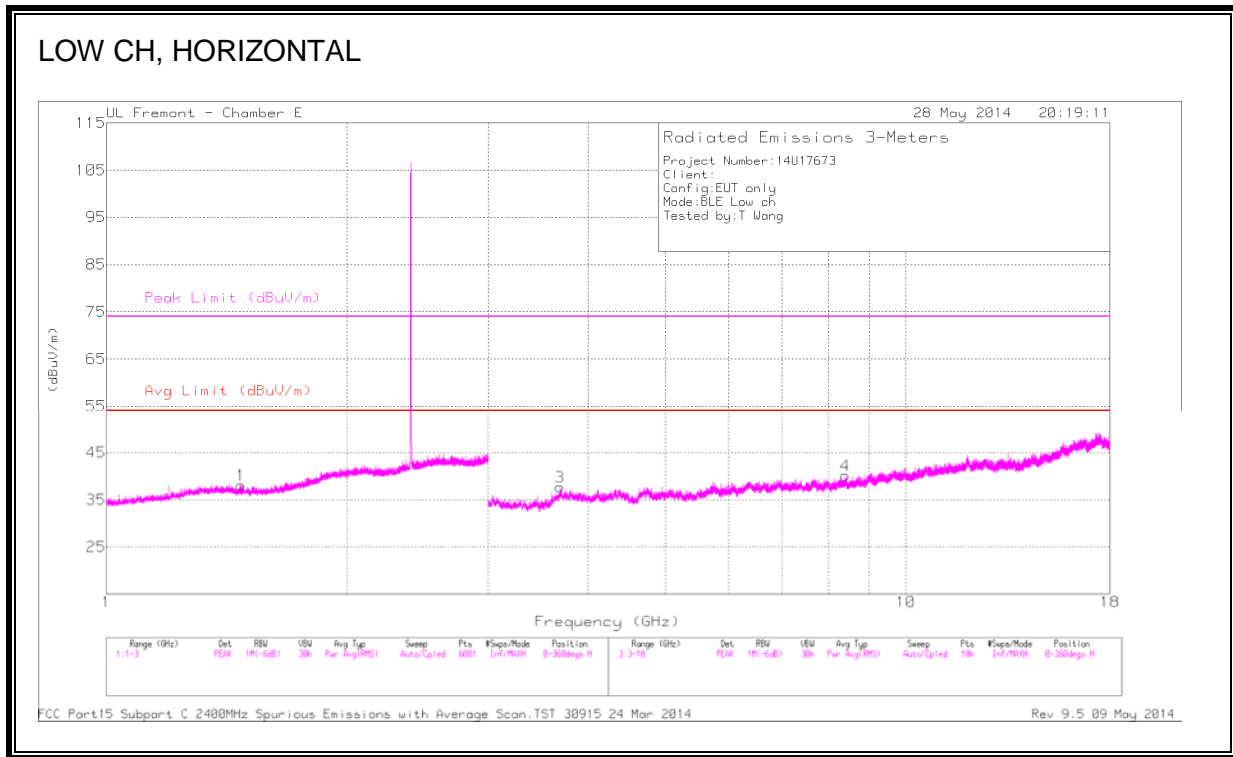

**DATA**

Trace Markers

Marker	Frequency (GHz)	Meter Reading (dBuV)	Det	AF T346 (dB/m)	Amp/Cbl/Filtr/ Pad (dB)	DC Corr (dB)	Corrected Reading (dBuV/m)	Avg Limit (dBuV/m)	Margin (dB)	Peak Limit (dBuV/m)	PK Margin (dB)	Azimuth (Degs)	Height (cm)	Polarity
1	* 1.472	44.02	PK2	28.5	-26.4	0	46.12	-	-	74	-27.88	360	165	H
	* 1.472	32.49	MAv1	28.5	-26.4	1.1	35.69	54	-18.31	-	-	360	165	H
2	* 1.474	43.68	PK2	28.5	-26.4	0	45.78	-	-	74	-28.22	360	126	V
	* 1.474	32.51	MAv1	28.5	-26.4	1.1	35.71	54	-18.29	-	-	360	126	V
3	* 3.691	41.83	PK2	33.3	-30.7	0	44.43	-	-	74	-29.57	360	175	H
	* 3.691	30.82	MAv1	33.3	-30.7	1.1	34.52	54	-19.48	-	-	360	175	H
4	* 8.402	38.91	PK2	35.9	-26.2	0	48.61	-	-	74	-25.39	360	175	H
	* 8.402	27.32	MAv1	35.9	-26.2	1.1	38.12	54	-15.88	-	-	360	175	H
5	* 3.802	42.28	PK2	33.4	-31.2	0	44.48	-	-	74	-29.52	360	131	V
	* 3.802	30.98	MAv1	33.4	-31.2	1.1	34.28	54	-19.72	-	-	360	131	V
6	* 8.258	38.7	PK2	35.9	-26.5	0	48.1	-	-	74	-25.9	360	131	V
	* 8.258	27.44	MAv1	35.9	-26.5	1.1	37.94	54	-16.06	-	-	360	131	V

\* - indicates frequency in CFR15.205/IC7.2.2 Restricted Band  
 PK2 - KDB558074 Method: Maximum Peak  
 MAv1 - KDB558074 Option 1 Maximum RMS Average

**MID CHANNEL HARMONICS AND SPURIOUS EMISSIONS**

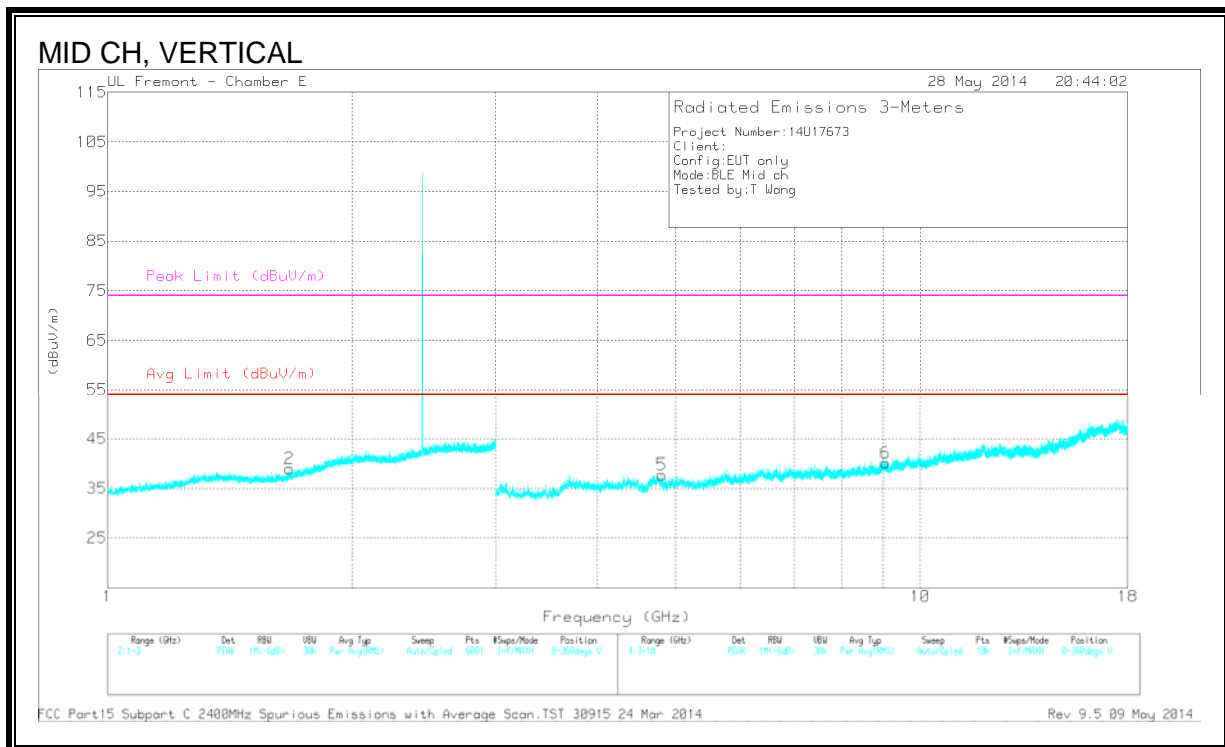
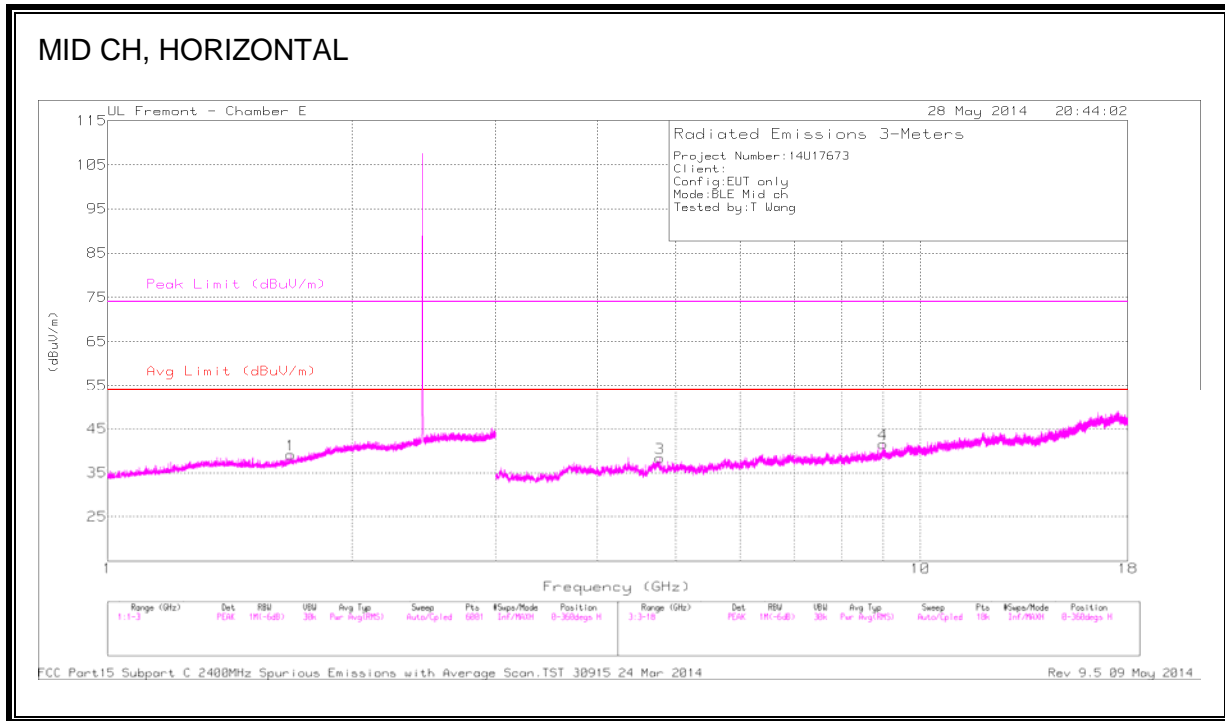

**DATA**

Marker	Frequency (GHz)	Meter Reading (dBuV)	Det	AF T346 (dB/m)	Amp/Cbl/Filtr/ Pad (dB)	DC Corr (dB)	Corrected Reading (dBuV/m)	Avg Limit (dBuV/m)	Margin (dB)	Peak Limit (dBuV/m)	PK Margin (dB)	Azimuth (Degs)	Height (cm)	Polarity
1	* 1.679	44.11	PK2	29	-26.3	0	46.81	-	-	74	-27.19	360	150	H
	* 1.679	32.54	MAv1	29	-26.3	1.1	36.34	54	-17.66	-	-	360	150	H
2	* 1.675	43.95	PK2	29	-26.3	0	46.65	-	-	74	-27.35	360	150	V
	* 1.675	32.62	MAv1	28.9	-26.3	1.1	36.32	54	-17.68	-	-	360	150	V
3	* 4.777	41.97	PK2	34.1	-31.1	0	44.97	-	-	74	-29.03	360	150	H
	* 4.777	29.91	MAv1	34.1	-31.1	1.1	34.01	54	-19.99	-	-	360	150	H
5	* 4.809	41.44	PK2	34.1	-31	0	44.54	-	-	74	-29.46	360	150	V
	* 4.809	29.88	MAv1	34.1	-31	1.1	34.08	54	-19.92	-	-	360	150	V
6	* 9.06	38.23	PK2	36.4	-25.3	0	49.33	-	-	74	-24.67	360	150	V
	* 9.06	26.51	MAv1	36.4	-25.3	1.1	38.71	54	-15.29	-	-	360	150	V
4	8.992	26.28	MAv1	36.3	-25	1.1	38.68	-	-	-	-	360	150	H
	8.992	38.19	PK2	36.3	-25	0	49.49	-	-	-	-	360	150	H

\* - indicates frequency in CFR15.205/IC7.2.2 Restricted Band  
 PK2 - KDB558074 Method: Maximum Peak  
 MAv1 - KDB558074 Option 1 Maximum RMS Average

**HIGH CHANNEL HARMONICS AND SPURIOUS EMISSIONS**

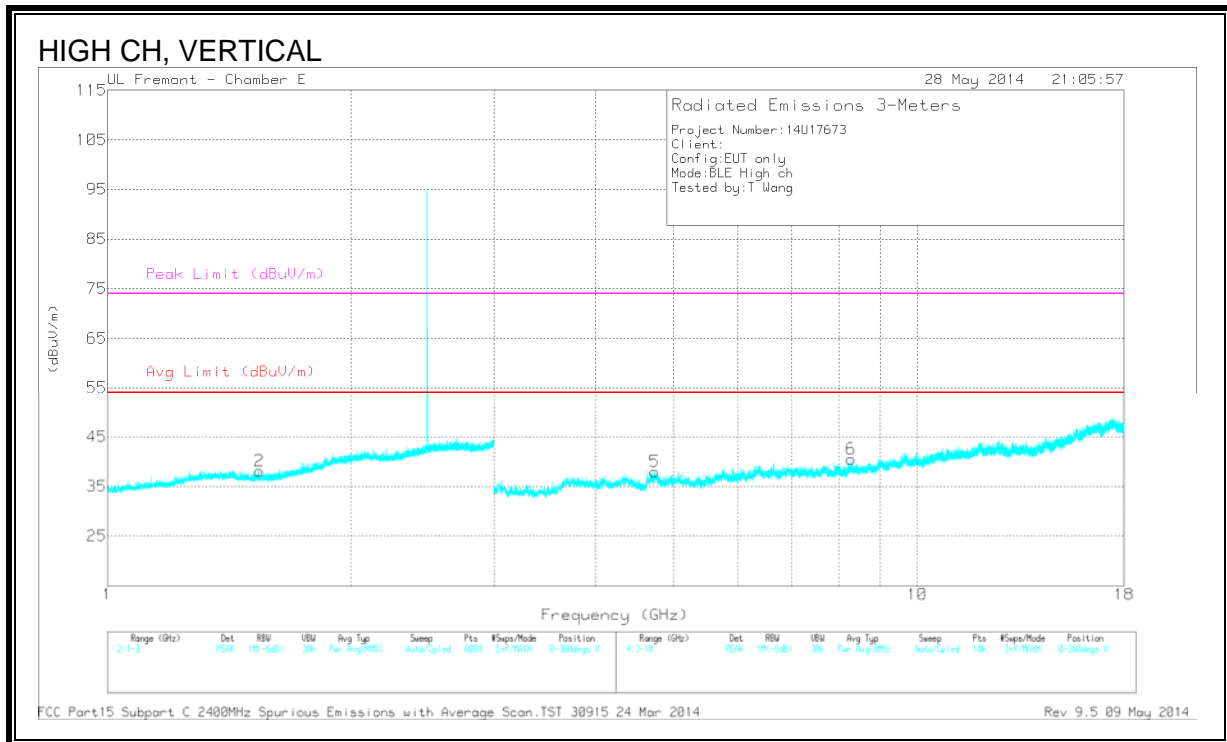
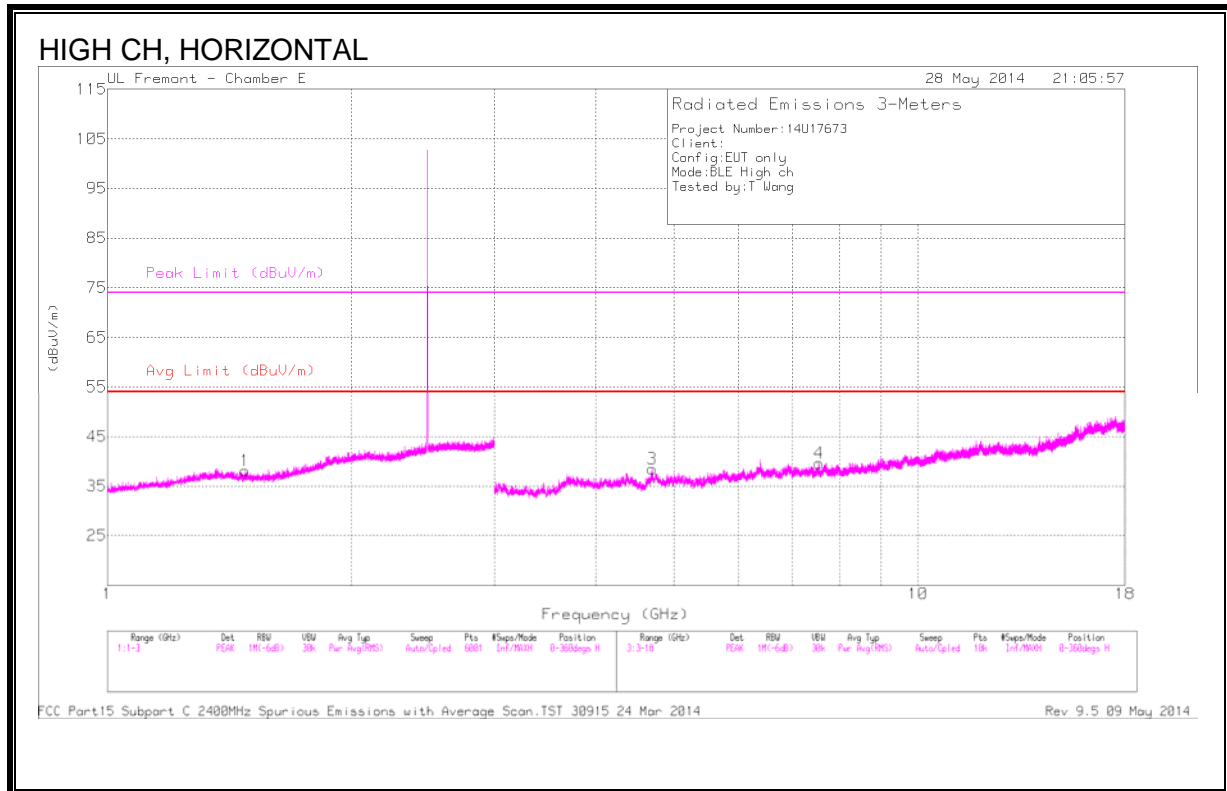

**DATA**

Marker	Frequency (GHz)	Meter Reading (dBuV)	Det	AF T346 (dB/m)	Amp/Cbl/Filtr/ Pad (dB)	DC Corr (dB)	Corrected Reading (dBuV/m)	Avg Limit (dBuV/m)	Margin (dB)	Peak Limit (dBuV/m)	PK Margin (dB)	Azimuth (Degs)	Height (cm)	Polarity
1	* 1.478	43.87	PK2	28.4	-26.3	0	45.97	-	-	74	-28.03	360	110	H
	* 1.478	32.66	MAv1	28.4	-26.3	1.1	35.86	54	-18.14	-	-	360	110	H
2	* 1.539	43.99	PK2	28.4	-26.3	0	46.09	-	-	74	-27.91	360	120	V
	* 1.539	32.56	MAv1	28.4	-26.3	1.1	35.76	54	-18.24	-	-	360	120	V
3	* 4.694	41.75	PK2	34.2	-30.2	0	45.75	-	-	74	-28.25	360	120	H
	* 4.694	30.03	MAv1	34.2	-30.2	1.1	35.13	54	-18.87	-	-	360	120	H
4	* 7.541	39.58	PK2	35.8	-28.2	0	47.18	-	-	74	-26.82	360	120	H
	* 7.541	28.23	MAv1	35.8	-28.2	1.1	36.93	54	-17.07	-	-	360	120	H
5	* 4.74	42.45	PK2	34.1	-30.8	0	45.75	-	-	74	-28.25	360	120	V
	* 4.74	30.54	MAv1	34.1	-30.8	1.1	34.94	54	-19.06	-	-	360	120	V
6	* 8.289	38.72	PK2	35.8	-26	0	48.52	-	-	74	-25.48	360	120	V
	* 8.289	27.05	MAv1	35.8	-26	1.1	37.95	54	-16.05	-	-	360	120	V

\* - indicates frequency in CFR15.205/IC7.2.2 Restricted Band  
 PK2 - KDB558074 Method: Maximum Peak  
 MAv1 - KDB558074 Option 1 Maximum RMS Average



## 10.2. WORST-CASE ABOVE 18 GHz

### SPURIOUS EMISSIONS 18 TO 26 GHz (WORST-CASE CONFIGURATION)

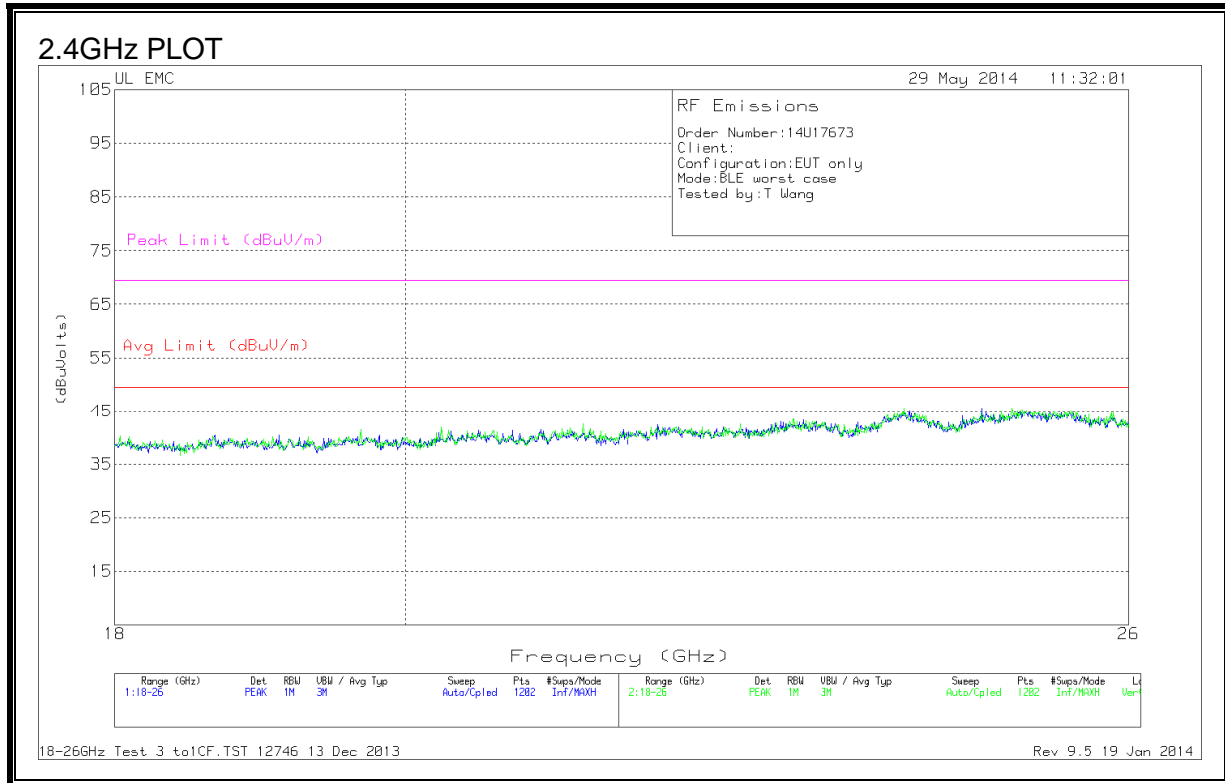

### 10.3. WORST-CASE BELOW 1 GHz

#### SPURIOUS EMISSIONS 30 TO 1000 MHz (WORST-CASE CONFIGURATION)

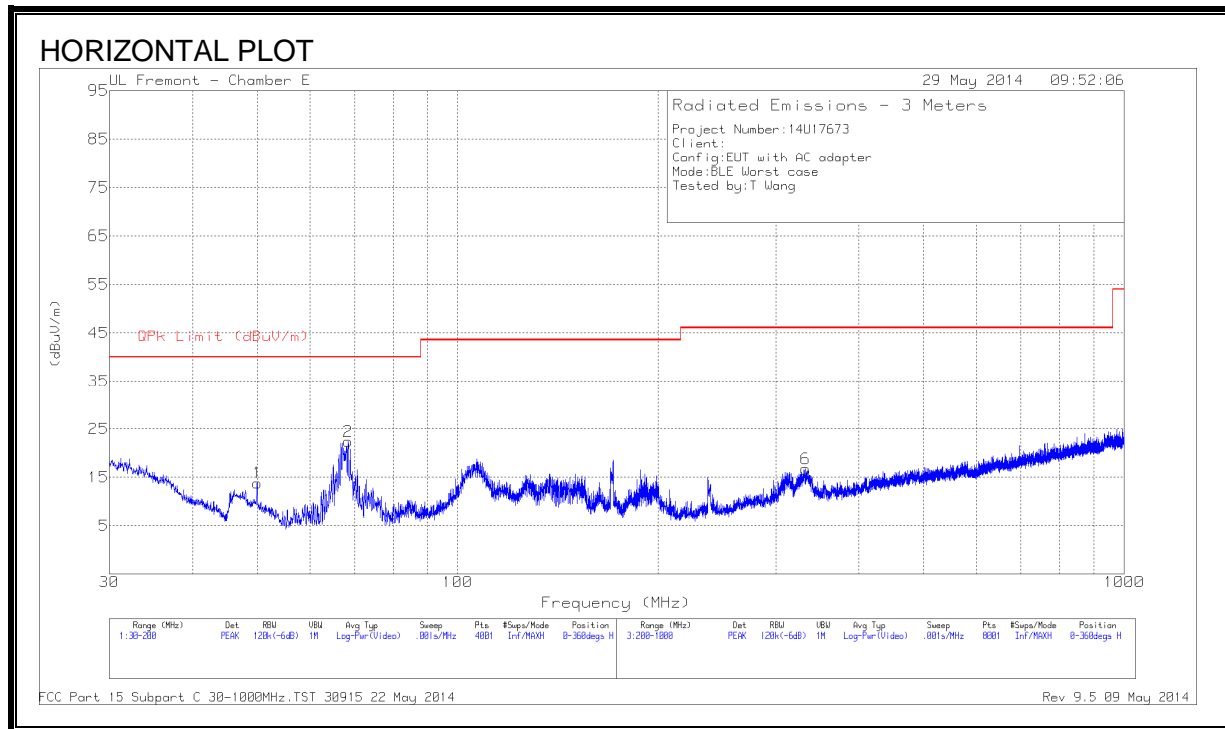

**SPURIOUS EMISSIONS 30 TO 1000 MHz (WORST-CASE CONFIGURATION, VERTICAL)**

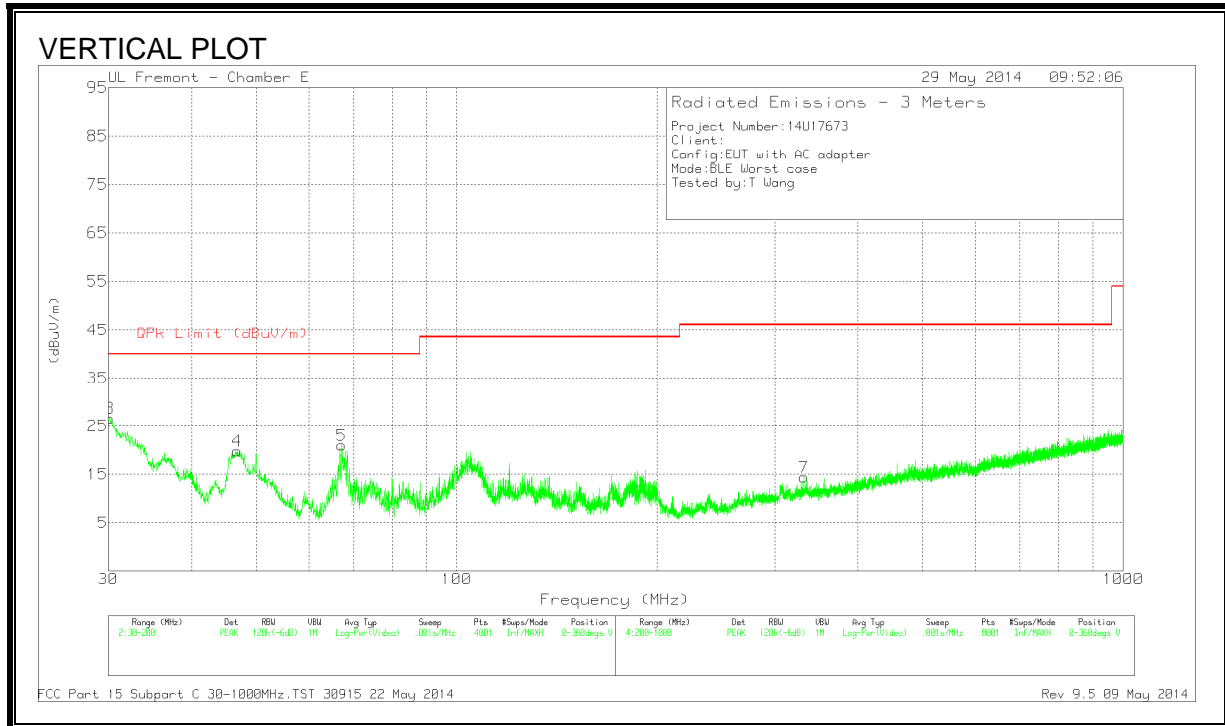

**DATA**

Trace Markers

Marker	Frequency (MHz)	Meter Reading (dBuV)	Det	Hybrid	Amp/Cbl (dB)	Corrected Reading (dBuV/m)	QPk Limit (dBuV/m)	Margin (dB)	Azimuth (Degs)	Height (cm)	Polarity
6	* 332.6	32.83	PK	14	-30.1	16.73	46.02	-29.29	0-360	100	H
7	* 331.6	30.6	PK	14	-30.2	14.4	46.02	-31.62	0-360	100	V
3	30.1275	36.97	PK	21.4	-31.8	26.57	40	-13.43	0-360	100	V
4	46.83	42.13	PK	9.4	-31.7	19.83	40	-20.17	0-360	100	V
1	50.0175	37.54	PK	7.9	-31.6	13.84	40	-26.16	0-360	200	H
5	67.23	44.54	PK	8.1	-31.6	21.04	40	-18.96	0-360	100	V
2	68.4625	45.78	PK	8.1	-31.5	22.38	40	-17.62	0-360	200	H

\* - indicates frequency in CFR15.205/IC7.2.2 Restricted Band  
 PK - Peak detector

## 11. AC POWER LINE CONDUCTED EMISSIONS

### LIMITS

FCC §15.207 (a)

RSS-Gen 7.2.2

Frequency of Emission (MHz)	Conducted Limit (dBuV)	
	Quasi-peak	Average
0.15-0.5	66 to 56*	56 to 46*
0.5-5	56	46
5-30	60	50

\*Decreases with the logarithm of the frequency.

### TEST PROCEDURE

The EUT is placed on a non-conducting table 40 cm from the vertical ground plane and 80 cm above the horizontal ground plane. The EUT is configured in accordance with ANSI C63.4.

The receiver is set to a resolution bandwidth of 9 kHz. Peak detection is used unless otherwise noted as quasi-peak or average.

Line conducted data is recorded for both NEUTRAL and HOT lines.

**RESULTS**

**6 WORST EMISSIONS**

Line-L1 .15 - 30MHz

**Trace Markers**

Marker	Frequency (MHz)	Meter Reading (dBuV)	Det	T24 IL L1 (dB)	LC Cables 1&3 (dB)	Corrected Reading dBuV	CISPR 22 Class B QP	Margin to Limit (dB)	CISPR 22 Class B Avg	Margin to Limit (dB)
1	.1635	40.59	PK	1.2	0	41.79	65.3	-23.51	-	-
2	.1635	18.67	Av	1.2	0	19.87	-	-	55.3	-35.43
3	.582	33.55	PK	.3	0	33.85	56	-22.15	-	-
4	.582	18.73	Av	.3	0	19.03	-	-	46	-26.97
5	.7665	42.86	PK	.3	0	43.16	56	-12.84	-	-
6	.7665	26.7	Av	.3	0	27	-	-	46	-19

Line-L2 .15 - 30MHz

**Trace Markers**

Marker	Frequency (MHz)	Meter Reading (dBuV)	Det	T24 IL L2 (dB)	LC Cables 2&3 (dB)	Corrected Reading dBuV	CISPR 22 Class B QP	Margin to Limit (dB)	CISPR 22 Class B Avg	Margin to Limit (dB)
7	.1635	39.9	PK	1.3	0	41.2	65.3	-24.1	-	-
8	.1635	18.06	Av	1.3	0	19.36	-	-	55.3	-35.94
9	.7125	36.02	PK	.3	0	36.32	56	-19.68	-	-
10	.7125	19.11	Av	.3	0	19.41	-	-	46	-26.59
11	.762	41.09	PK	.3	0	41.39	56	-14.61	-	-
12	.762	27.76	Av	.3	0	28.06	-	-	46	-17.94

PK - Peak detector

Av - average detection

**LINE 1 RESULTS**

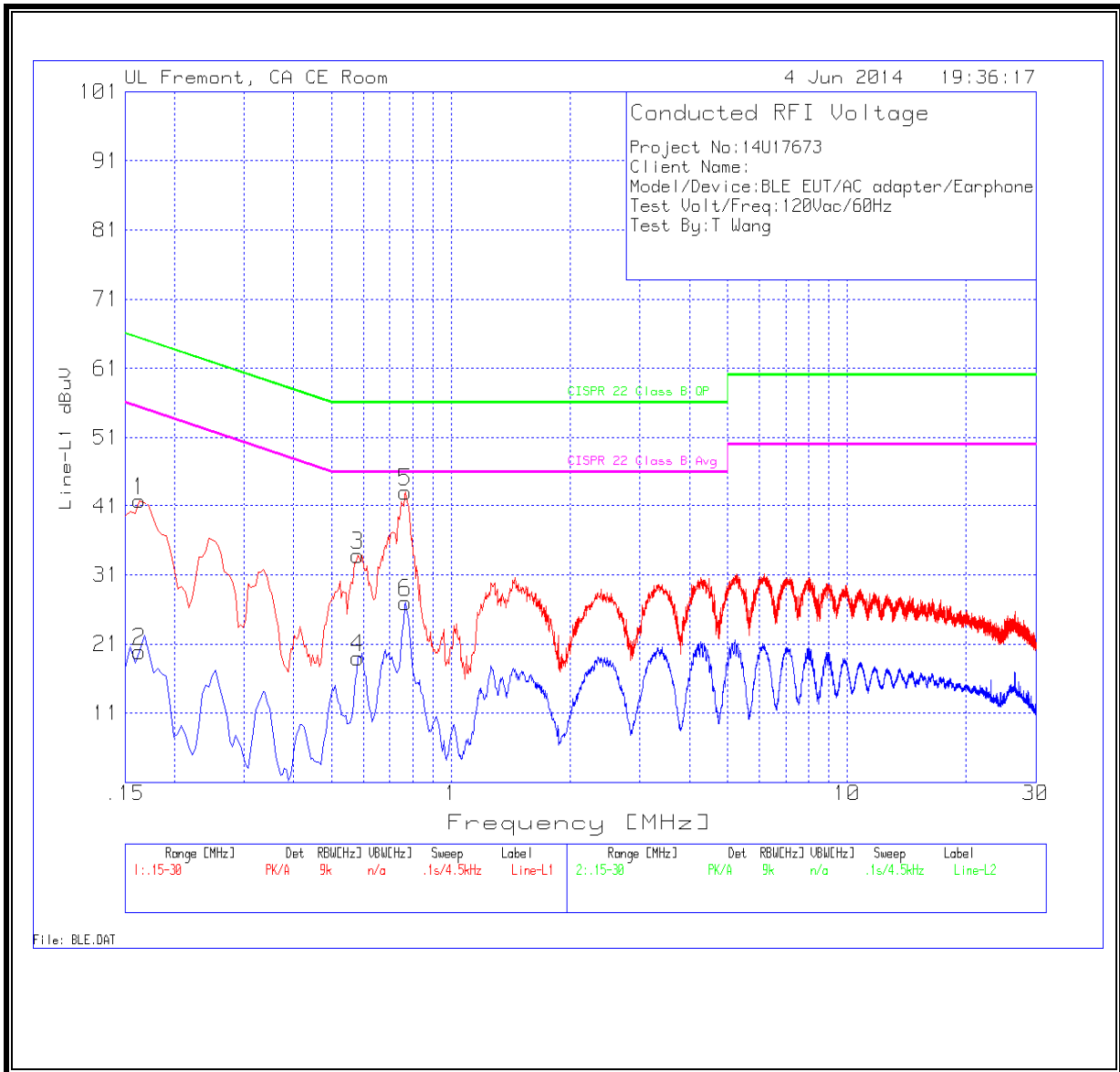

**LINE 2 RESULTS**

