



**FCC CFR47 PART 20.19
ANSI C63.19-2011**

HAC RF EMISSIONS TEST REPORT

For
iPhone

**Model: A1428, A1429
FCC ID: BCG-E2599A**

REPORT NUMBER: 11U14136-5B1

ISSUE DATE: 9/11/2012

Prepared for
**APPLE INC.
1 INFINITE LOOP, MS 26A
CUPERTINO, CA 95014-2084**

Prepared by
**UL CCS
47173 BENICIA STREET
FREMONT, CA 94538, U.S.A.
TEL: (510) 771-1000
FAX: (510) 661-0888**



NVLAP LAB CODE 200065-0

Revision History

<u>Rev.</u>	<u>Issue Date</u>	<u>Revisions</u>	<u>Revised By</u>
--	8/10/2012	Initial Issue	--
A	8/15/2012	Updated Section 5.2	Sunny Shih
A1	9/4/2012	Made the following revision: 1. Sec. 1: Added Maximum E-field emission results for Part 90. 2. Sec. 4.1: Added note (MIF information) below measuring instrument table. 3. Sec. 4.2: Measurement Uncertainty - Corrected "PC63.19" to "C63.19" - Added "Scaling to PMR Calibration" in error description 4. Sec. 8: Modulation Interference Factor (MIF) 5. Sec. 11 HAC RF Emission Test Results - Updated test results table	Sunny Shih
B	9/10/2012	Made the following revision: 1. Sec. 5.1 & 5.2: Changed Voice Over Digital Transport (data) for LTE bands from "No" to "Yes"	
B1	09/11/2012	Update Section 8 with UID information and added UID specification in the appendix.	

Table of Contents

1. Attestation of Test Results	4
2. Test Methodology	5
3. Facilities and Accreditation	5
4. Calibration and Uncertainty	6
4.1. <i>Measuring Instrument Calibration.....</i>	<i>6</i>
4.2. <i>Measurement Uncertainty.....</i>	<i>7</i>
5. Device Under Test	8
5.1. <i>List of Air Interfaces/Bands & Operating Modes for Model A1428</i>	<i>8</i>
5.2. <i>List of Air Interfaces/Bands & Operating Modes for Model A1429</i>	<i>9</i>
6. System Specifications.....	10
7. System Validation.....	11
7.1. <i>System Validation Results.....</i>	<i>12</i>
8. Modulation Interference Factor (MIF).....	13
9. HAC RF Emissions Test Procedure	14
10. RF Emissions Measurement Criteria	17
11. HAC (RF Emissions) Test Results.....	17
11.1. <i>Test Results for model A1428.....</i>	<i>17</i>
11.1.1. <i>Primary Antenna</i>	<i>17</i>
11.1.2. <i>Secondary Antenna</i>	<i>17</i>
11.2. <i>Test Results for model A1429.....</i>	<i>18</i>
11.2.1. <i>Primary Antenna</i>	<i>18</i>
11.2.2. <i>Secondary Antenna</i>	<i>18</i>
12. Worst-case Test Plots	19
13. Appendixes	24
13.1. <i>System Validation Plots</i>	<i>24</i>
13.2. <i>E-Field Emissions Test Plots</i>	<i>24</i>
13.3. <i>Calibration Certificate - E-Field Probe ER3DV6 - SN 2509</i>	<i>24</i>
13.4. <i>Calibration Certificate - E-Field Probe ER3DV6 - SN 2516</i>	<i>24</i>
13.5. <i>Calibration Certificate for Dipole CD835V3 - SN 1175.....</i>	<i>24</i>
13.6. <i>Calibration Certificate for Dipole CD1880V3 - SN 1159.....</i>	<i>24</i>
14. Setup Photo.....	25

1. Attestation of Test Results

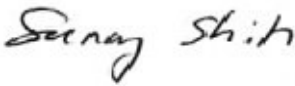
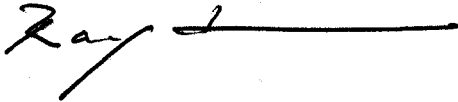
Applicant name	Apple Inc.	
DUT description	iPhone	
Model name	A1428, A1429	
Test device is	An identical prototype	
Device category	Portable	
Exposure category	General Population/Uncontrolled Exposure	
Test Dates	7/2/2012 – 7/3/2012, 7/18/2012 – 7/19/2012, 7/30/2012	
Maximum E-Field Emissions		
Max. E-Field emissions	Model A1428	
	Part 22 - Cellular band:	40.43 dB V/m (M3)_GSM850
	Part 24 - PCS band:	34.78 dB V/m (M3)_ GSM1900
	Model A1429	
	Part 22 - Cellular band:	18.39 dB V/m (M4)_CDMA BC0
	Part 24 - PCS band:	13.51 dB V/m (M4)_CDMA BC1
	Part 90	17.77 dB V/m (M4)_CDMA BC10
Hearing Aid Near-Field Category: M3 (for model A1428) M4 (for model A1429)		
Applicable Standards	Test Results	
ANSI C63.19-2011	Pass	
<p>Compliance Certification Services, Inc. (UL CCS) tested the above equipment in accordance with the requirements set forth in the above standards. All indications of Pass/Fail in this report are opinions expressed by UL CCS based on interpretations and/or observations of test results. Measurement Uncertainties were not taken into account and are published for informational purposes only. The test results show that the equipment tested is capable of demonstrating compliance with the requirements as documented in this report.</p> <p>Note: The results documented in this report apply only to the tested sample, under the conditions and modes of operation as described herein. This document may not be altered or revised in any way unless done so by UL CCS and all revisions are duly noted in the revisions section. Any alteration of this document not carried out by UL CCS will constitute fraud and shall nullify the document. This report must not be used by the client to claim product certification, approval, or endorsement by NVLAP, NIST, any agency of the Federal Government, or any agency of any government (NIST Handbook 150, Annex A). This report is written to support regulatory compliance of the applicable standards stated above.</p>		
Approved & Released For UL CCS By:	Tested By:	
		
Sunny Shih Engineering Team Leader Compliance Certification Services (UL CCS)	Ray Su SAR Engineer Compliance Certification Services (UL CCS)	

2. Test Methodology

The tests documented in this report were performed in accordance with ANSI C63.19-2011 Methods of Measurement of Compatibility between Wireless Communications Devices and Hearing Aids and FCC KDB 285076 D01 HAC Guidance v02r01

3. Facilities and Accreditation

The test sites and measurement facilities used to collect data are located at 47173 Benicia Street, Fremont, California, USA.

UL CCS is accredited by NVLAP, Laboratory Code 200065-0. The full scope of accreditation can be viewed at <http://www.ccsemc.com>.

4. Calibration and Uncertainty

4.1. Measuring Instrument Calibration

The measuring equipment utilized to perform the tests documented in this report has been calibrated in accordance with the manufacturer's recommendations, and is traceable to recognized national standards.

Name of Equipment	Manufacturer	Type/Model	Serial No.	Cal. Due date		
				MM	DD	Year
Robot - Six Axes	Stäubli	TX90 XL	N/A	N/A		
Robot Remote Control	Stäubli	CS8C	N/A	N/A		
DASY5 Measurement Server	SPEAG	SEUMS001BA	1041	N/A		
Probe Alignment Unit	SPEAG	LB (V2)	261	N/A		
Data Acquisition Electronics	SPEAG	DAE4	1239	6	6	2013
Radio Communication Tester	R & S	CMU 200	106301	6	6	2013
E-Field Probe	SPEAG	ER3DV6*	2509	6	20	2013
E-Field Probe	SPEAG	ER3DV6*	2516	8	8	2012
Calibration Dipole	SPEAG	CD835V3	1175	6	11	2013
Calibration Dipole	SPEAG	CD1880V3	1159	6	11	2013
Amplifier	MITEQ	4D00400600-50-30P	1620606	N/A		
Directional coupler	Werlatone	C8060-102	2141	N/A		

Note(s):

*: According to SPEAG's Technical Report, "MIF Verification", Doc # TR-FB-12.09.04-1, issued date: 9/4/2012. E-field probes are calibrated with specified uncertainty according to ISO 17025 as described in their calibration certificate. The MIF according to the definition in ANSI C63.19 is specific for a modulation and can therefore be used as a constant value if the probe has been PMR calibrated.

4.2. Measurement Uncertainty

HAC Uncertainty Budget According to ANSI C63.19

Error Description	Uncertainty value ($\pm\%$)	Probe Dist.	Div.	(Ci) E	(Ci) H	Std. Unc. ($\pm\%$)	
						E	H
Measurement System							
Probe Calibration	5.1	N	1	1	1	5.1	5.10
Axial Isotropy	4.7	R	1.732	1	1	2.7	2.71
Sensor Displacement	16.5	R	1.732	1	0.145	9.5	1.38
Boundary Effects	2.4	R	1.732	1	1	1.4	1.39
Phantom Boundary Effects	7.2	R	1.732	1	0	4.1	0.00
Linearity	4.7	R	1.732	1	1	2.7	2.71
Scaling to PMR Calibration	10.0	R	1.732	1	1	2.8	5.77
System Detection Limit	1.0	R	1.732	1	1	0.6	0.58
Readout Electronics	0.3	N	1	1	1	0.3	0.30
Response Time	0.8	R	1.732	1	1	0.5	0.46
Integration Time	2.6	R	1.732	1	1	1.5	1.50
RF Ambient Conditions	3.0	R	1.732	1	1	1.7	1.73
RF Reflections	12.0	R	1.732	1	1	6.9	6.93
Probe Positioner	1.2	R	1.732	1	0.67	0.7	0.46
Probe Positioning	4.7	R	1.732	1	0.67	2.7	1.82
Extrapolation and Interpolation	1.0	R	1.732	1	1	0.6	0.58
Test sample Related							
Test Positioning Vertical	4.7	R	1.732	1	0.67	2.7	1.82
Test Positioning Lateral	1.0	R	1.732	1	1	0.6	0.58
Device Holder and Phantom	2.4	R	1.732	1	1	1.4	1.39
Power Drift	5.0	R	1.732	1	1	2.9	2.89
Phantom and Setup Related							
Phantom Thickness	2.4	R	1.732	1	0.67	1.4	0.93
Combined Std. Uncertainty						15.4	12.2
Expanded Std. Uncertainty on Power						30.8	24.4
Expanded Std. Uncertainty on Field						15.4	12.2
Notes for table							
1. N - Normal							
2. R - Rectangular							
3. Div. - Divisor used to obtain standard uncertainty							
4. Ci - is the sensitivity coefficient							

5. Device Under Test

iPhone	
Model: A1428, A1429	
Normal operation:	Held to head
Accessory:	Standard cover

5.1. List of Air Interfaces/Bands & Operating Modes for Model A1428

Air-Interface	Bands (MHz)	Type	C63.19/ Tested	Simultaneous Transmissions Note: Not to be tested	Concurrent single transmission*	Reduced power 20.19 (c) (1)	Voice Over Digital Transport (Data)
GSM	850	VO	Yes	Yes With WiFi/Bluetooth	Yes: GPRS/EDGE,W-CDMA, LTE and WiFi/Bluetooth	N/A	N/A
	1900		Yes				
	GPRS/EDGE	DT	No	N/A	Yes: * see note	N/A	Yes
W-CDMA	Band V & II R 99	VO	Yes	Yes With WiFi/Bluetooth	Yes: GSM, HSPA, LTE and WiFi/Bluetooth	N/A	N/A
	HSDPA	DT	No	N/A	Yes: * see note	N/A	Yes
LTE	Band 2 (1900)	DT	No	Yes With WiFi/Bluetooth	Yes: GSM,W-CDMA and WiFi/Bluetooth	N/A	Yes
	Band 4 (1750)					N/A	Yes
	Band 5 (850)					N/A	Yes
	Band 17 (700)					N/A	Yes
WiFi	2450	DT	No	Yes GSM, W-CDMA and LTE	Yes GSM, W-CDMA LTE and Bluetooth	N/A	Yes
	5000			Yes GSM, W-CDMA LTE and Bluetooth	Yes GSM, W-CDMA LTE and Bluetooth		
Bluetooth	2400	DT	N/A	Yes with GSM/W-CDMA	N/A	N/A	N/A
VO Voice CMRS/PTSN Service Only V/D Voice CMRS/PSTN and Data Service DT Digital Transport				Note: * HAC Rating was not base on concurrent voice and data modes, Noncurrent mode was found to represent worst case rating.			

5.2. List of Air Interfaces/Bands & Operating Modes for Model A1429

Air-Interface	Bands (MHz)	Type	C63.19/ Tested	Simultaneous Transmissions Note: Not to be tested	Concurrent single transmission*	Reduced power 20.19 (c) (1)	Voice Over Digital Transport (Data)
CDMA	BC0	VO	Yes	Yes With WiFi/Bluetooth	Yes: LTE and WiFi/Bluetooth	N/A	N/A
	BC1		Yes				
	BC10		Yes				
	EV-DO	DT	No	N/A	Yes: * see note	N/A	Yes
LTE	Band 5 (850)	DT	No	Yes With WiFi/Bluetooth	Yes: CDMA and WiFi/Bluetooth	N/A	Yes
	Band 13 (750)					N/A	Yes
	Band 25 (1900)					N/A	Yes
WiFi	2450	DT	No	Yes CDMA and LTE	Yes CDMA, LTE and Bluetooth	N/A	Yes
	5000			Yes CDMA, LTE and Bluetooth	Yes CDMA, LTE and Bluetooth		
Bluetooth	2400	DT	N/A	Yes with GSM/W-CDMA	N/A	N/A	N/A
VO Voice CMRS/PTSN Service Only V/D Voice CMRS/PSTN and Data Service DT Digital Transport				Note: * HAC Rating was not base on concurrent voice and data modes, Noncurrent mode was found to represent worst case rating.			

6. System Specifications

E-field measurements are performed using the DASY5 automated dosimetric assessment system. The DASY5 is made by Schmid & Partner Engineering AG (SPEAG) in Zurich, Switzerland.

The DASY5 HAC Extension consists of the following parts:

Test Arch Phantom

The specially designed Test Arch allows high precision positioning of both the device and any of the validation dipoles.

ER3DV6 Isotropic E-Field Probe

Construction:	One dipole parallel, two dipoles normal to probe axis Built-in shielding against static charges PEEK enclosure material (resistant to organic solvents, e.g., glycoether)
Calibration:	In air from 100 MHz to 3.0 GHz (absolute accuracy $\pm 6.0\%$, $k=2$)
Frequency:	100 MHz to > 6 GHz; Linearity: ± 0.2 dB (100 MHz to 3 GHz)
Directivity:	± 0.2 dB in air (rotation around probe axis) ± 0.4 dB in air (rotation normal to probe axis)
Dynamic Range:	2 V/m to > 1000 V/m; Linearity: ± 0.2 dB
Dimensions:	Overall length: 330 mm (Tip: 16 mm) Tip diameter: 8 mm (Body: 12 mm) Distance from probe tip to dipole centers: 2.5 mm The closest part of the sensor element is 1.1 mm closer to the tip
Application:	General near-field measurements up to 6 GHz Field component measurements

7. System Validation

The test setup was validated when first configured and verified periodically thereafter to ensure proper function. The procedure provided in this section is a validation procedure using dipole antennas for which the field levels were computed by numeric modeling.

Procedure

Place a dipole antenna meeting the requirements given in ANSI C63.19-2011 in the normally occupied by the WD.

The dipole antenna serves as a known source for an electrical and magnetic output. Position the E-field probe so that the following occurs:

- The probes and their cables are parallel to the coaxial feed of the dipole antenna
- The probe cables and the coaxial feed of the dipole antenna approach the measurement area from opposite directions
- The center point of the probe element(s) is 15 mm from the closest surface of the dipole elements.

Scan the length of the dipole with the E-field probe and record the two maximum values found near the dipole ends. Average the two readings and compare the reading to the expected value in the calibration certificate or the expected value in this standard.

Setup diagram

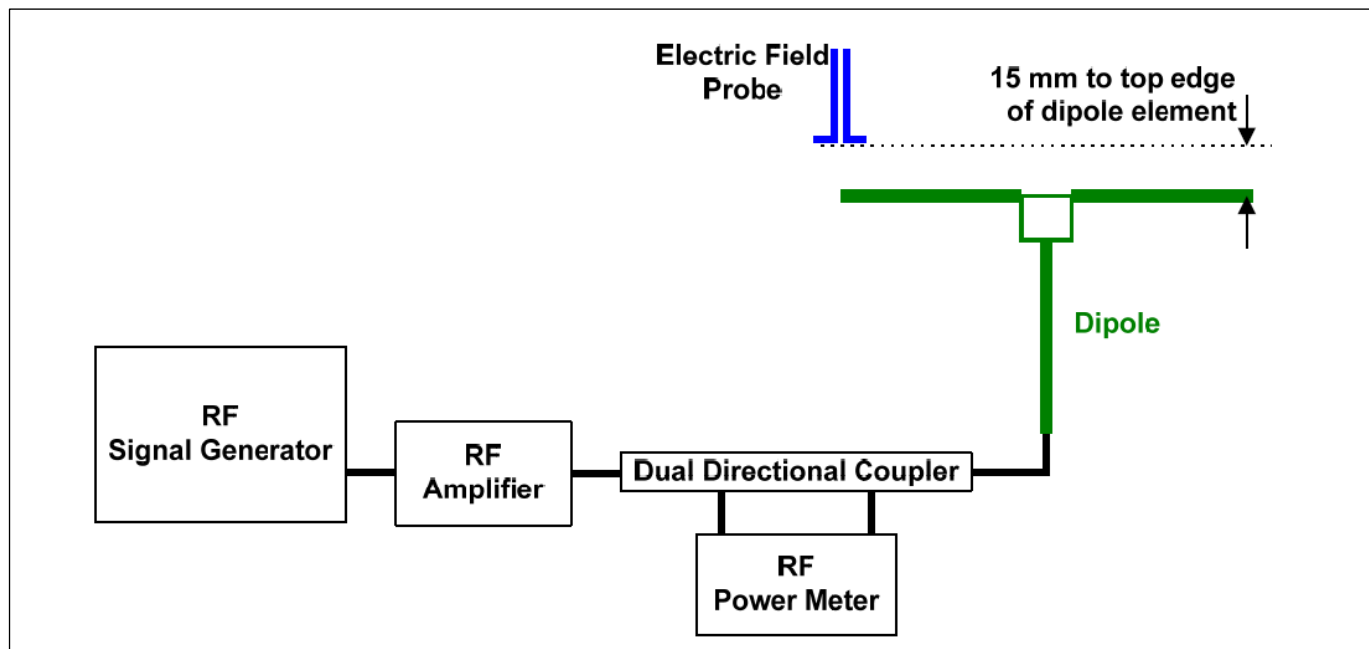

7.1. System Validation Results

2012-7-02

E-field Probe ER3DV6 SN2509							
Calibration Dipole	f (MHz)	Input Power (mW)	Max. measured from		Average max. above arm (V/m)	E-field Target Values (V/m) (From SPEAG)	Deviation ¹⁾ (%)
			above high end (V/m)	above low end (V/m)			
CD835V3 SN 1175	835	100	112.3	105.1	108.70	104.6	3.92
CD1880V3 SN 1159	1880	100	89.5	89.8	89.63	87.1	2.90

E-field Probe ER3DV6 SN2516							
Calibration Dipole	f (MHz)	Input Power (mW)	Max. measured from		Average max. above arm (V/m)	E-field Target Values (V/m) (From SPEAG)	Deviation ¹⁾ (%)
			above high end (V/m)	above low end (V/m)			
CD835V3 SN 1175	835	100	109.2	104.4	106.80	104.6	2.10
CD1880V3 SN 1159	1880	100	86.9	87.3	87.11	87.1	0.01

2012-7-18

E-field Probe ER3DV6 SN2509							
Calibration Dipole	f (MHz)	Input Power (mW)	Max. measured from		Average max. above arm (V/m)	E-field Target Values (V/m) (From SPEAG)	Deviation ¹⁾ (%)
			above high end (V/m)	above low end (V/m)			
CD835V3 SN 1175	835	100	110.2	103.4	106.80	104.6	2.10
CD1880V3 SN 1159	1880	100	89.3	89.5	89.38	87.1	2.62

E-field Probe ER3DV6 SN2516							
Calibration Dipole	f (MHz)	Input Power (mW)	Max. measured from		Average max. above arm (V/m)	E-field Target Values (V/m) (From SPEAG)	Deviation ¹⁾ (%)
			above high end (V/m)	above low end (V/m)			
CD835V3 SN 1175	835	100	109.1	104.0	106.55	104.6	1.86
CD1880V3 SN 1159	1880	100	86.9	87.4	87.15	87.1	0.06

2012-7-30

E-field Probe ER3DV6 SN2516							
Calibration Dipole	f (MHz)	Input Power (mW)	Max. measured from		Average max. above arm (V/m)	E-field Target Values (V/m) (From SPEAG)	Deviation ¹⁾ (%)
			above high end (V/m)	above low end (V/m)			
CD1880V3 SN 1159	1880	100	86.8	87.2	87.00	87.1	-0.11

Notes:

- 1) Delta (Deviation) % = 100 * (Measured value minus Target value) divided by the Target value. Deltas within ±25% are acceptable, of which 12% is deviation and 13% is measurement uncertainty.
- 2) The maximum E-field or were evaluated and compared to the target values provided by SPEAG in the calibration certificate of specific dipoles.
- 3) Please refer to the appendix for detailed measurement data and plots.

8. Modulation Interference Factor (MIF)

The HAC Standard ANSI C63.19-2011 defines a new scaling using the Modulation Interference Factor (MIF) which replaces the need for the Articulation Weighting Factor (AWF) during the evaluation and is applicable to any modulation scheme.

The Modulation Interference factor (MIF, in dB) is added to the measured average E-field (in dBV/m) and converts it to the RF Audio Interference level (in dBV/m). This level considers the audible amplitude modulation components in the RF E-field. CW fields without amplitude modulation are assumed to not interfere with the hearing aid electronics. Modulations without time slots and low fluctuations at low frequencies have low MIF values, TDMA modulations with narrow transmission and repetition rates of few 100 Hz have high MIF values and give similar classifications as ANSI C63-2007.

Definitions

ER3D, E-field probes have a bandwidth <10 kHz and can therefore not evaluate the RF envelope in the full audio band. DASY52 is therefore using the "indirect" measurement method according to ANSI C63.19-2011 which is the primary method. These near field probes read the averaged E-field measurement. Especially for the new high peak-to-average (PAR) signal types, the probes shall be linearized by probe modulation response (PMR) calibration in order to not overestimate the field reading.

The evaluation method or the MIF is defined in ANSI C63.19-2011 section D.7. An RMS demodulated RF signal is fed to a spectral filter (similar to an A weighting filter) and forwarded to a temporal filter acting as a quasi-peak detector. The averaged output of these filtering is called to a 1 kHz 80% AM signal as reference. MIF measurement requires additional instrumentation and is not well suited for evaluation by the end user with reasonable uncertainty. It may alternatively be determined through analysis and simulation, because it is constraint and characteristic for a communication signal. DASY52 uses well defined signals for PMR calibration. The MIF of these signals has been determined by simulation and is automatically applied.

MIF values were not tested by a probe or as specified in the standards but are based on analysis provided by SPEAG for all the air interfaces (GSM, WCDMA, CDMA). For GSM, User Identifier (UID) 10021 was used; for CDMA2000, UID 10081 was used; for WCDMA, UID 10011 was used. The data included in this report are for the worst case operating modes.

UID	Communication System Name	MIF (dB)
10011	UMTS-FDD (WCDMA)	-20.49
10021	GSM-FDD (TDMA, GMSK)	3.60
10081	CDMA2000 (1xRTT, RC3)	-19.77

A PMR calibrated probe is linearized for the selected waveform over the full dynamic range within the uncertainty specified in its calibration certificate. ER3D, EF3D and EU2D E-field probes have a bandwidth <10 kHz and can therefore not evaluate the RF envelope in the full audio band. DASY52 is therefore using the "indirect" measurement method according to ANSI C63.19-2011 which is the primary method. These near field probes read the averaged E-field measurement. Especially for the new high peak-to-average (PAR) signal types, the probes shall be linearized by PMR calibration in order to not overestimate the field reading. The evaluation method for the MIF is defined in ANSI C63.19-2011 section D.7. An RMS demodulated RF signal is fed to a spectral filter (similar to an A weighting filter) and forwarded to a temporal filter acting as a quasi-peak detector. The averaged output of these filtering is scaled to a 1 kHz 80% AM signal as reference. MIF measurement requires additional instrumentation and is not well suited for evaluation by the end user with reasonable uncertainty. It may alternatively be determined through analysis and simulation, because it is constant and characteristic for a communication signal. DASY52 uses well-defined signals for PMR calibration. The MIF of these signals has been determined by simulation and is automatically applied. The MIF measurement uncertainty is estimated as follows, for modulation frequencies from slotted waveforms with fundamental frequency and at least 2 harmonics within 10 kHz:

- 0.2 dB for MIF -7 to +5 dB,
- 0.5 dB for MIF -13 to +11 dB
- 1 dB for MIF > -20 dB

9. HAC RF Emissions Test Procedure

The following are step-by-step test procedures.

- a) Confirm proper operation of the field probe, probe measurement system and other instrumentation and the positioning system.
- b) Position the WD in its intended test position.
- c) Set the WD to transmit a fixed and repeatable combination of signal power and modulation characteristic that is representative of the worst case (highest interference potential) encountered in normal use. Transiently occurring start-up, changeover, or termination conditions, or other operations likely to occur less than 1% of the time during normal operation, may be excluded from consideration.
- d) The center sub-grid shall be centered on the T-Coil mode perpendicular measurement point or the acoustic output, as appropriate. Locate the field probe at the initial test position in the 50 mm by 50 mm grid, which is contained in the measurement plane, refer to illustrated in Figure 1. If the field alignment method is used, align the probe for maximum field reception.
- e) Record the reading at the output of the measurement system
- f) Scan the entire 50 mm by 50 mm region in equally spaced increments and record the reading at each measurement point. The distance between measurement points shall be sufficient to assure the identification of the maximum reading.
- g) Identify the five contiguous sub-grids around the center sub-grid whose maximum reading is the lowest of all available choices. This eliminates the three sub-grids with the maximum readings. Thus, the six areas to be used to determine the WD's highest emissions are identified.
- h) Identify the maximum reading within the non-excluded sub-grids identified in step g).
- i) Convert the highest field reading within identified in step h) to RF audio interference level, in V/m, by taking the square root of the reading and then dividing it by the measurement system transfer function, established in 5.5.1.1 Convert this result to dB(V/m) by taking the base-10 logarithm and multiplying by 20.

Indirect measurement method

Replacing step i), the RF audio interference level in dB (V/m) is obtained by adding the MIF (in dB) to the maximum steady-state rms field-strength reading, in dB(V/m), from step h). Use this result to determine the category rating

- j) Compare this RF audio interference level with the categories in Clause 8 (ANSI C63.19-2011) and record the resulting WD category rating
- k) For the T-Coil mode M-rating assessment, determine whether the chosen perpendicular measurement point is contained in an included sub-grid of the first scan. If so, then a second scan is not necessary. The first scan and resultant category rating may be used for the T-Coil mode M rating.

Otherwise, repeat step a) through step i), with the grid shifted so that it is centered on the perpendicular measurement point. Record the WD category rating.



Figure 1 - WD reference and plane for RF emission measurements

Test flowchart Per ANSI-PC63.19 2011

Test Instructions

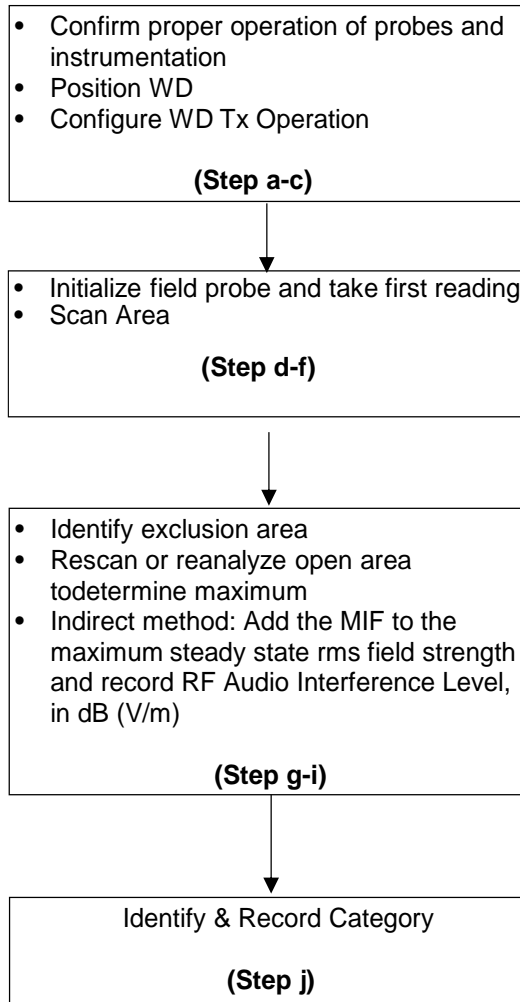

10. RF Emissions Measurement Criteria

WD RF audio interference level categories in logarithmic units

Emission Categories	E-field emissions	
	< 960 MHz	> 960 MHz
Category M1	50 to 55 dB (V/m)	40 to 45 dB (V/m)
Category M2	45 to 50 dB (V/m)	35 to 40 dB (V/m)
Category M3	40 to 45 dB (V/m)	30 to 35 dB (V/m)
Category M4	<40 dB (V/m)	<30 dB (V/m)

11. HAC (RF Emissions) Test Results

11.1. Test Results for model A1428

11.1.1. Primary Antenna

Operating Mode	Ch. No.	Freq. (MHz)	Results* (dB V/m)	M-Rating	Plots Page #
GSM850	128	824.2	40.43	M3	1
	190	836.6	40.43	M3	2
	251	848.8	39.89	M4	3
GSM1900	512	1850.2	34.16	M3	4
	661	1880.0	34.35	M3	5
	810	1909.8	34.26	M3	6
W-CDMA band V R99 RMC 12.2kbps	4132	826.4	16.56	M4	7
	4183	836.6	16.86	M4	8
	4233	846.6	16.20	M4	9
W-CDMA band II R99 RMC 12.2kbps	9262	1852.4	13.08	M4	10
	9400	1880.0	13.11	M4	11
	9538	1907.6	12.75	M4	12

11.1.2. Secondary Antenna

Operating Mode	Ch. No.	Freq. (MHz)	Results* (dB V/m)	M-Rating	Plots Page #
GSM850	128	824.2	38.52	M4	13
	190	836.6	39.12	M4	14
	251	848.8	40.36	M3	15
GSM1900	512	1850.2	33.46	M3	16
	661	1880.0	34.19	M3	17
	810	1909.8	34.78**	M3	18
W-CDMA band V R99 RMC 12.2kbps	4132	826.4	14.63	M4	19
	4183	836.6	16.24	M4	20
	4233	846.6	16.61	M4	21
W-CDMA band II R99 RMC 12.2kbps	9262	1852.4	10.07	M4	22
	9400	1880.0	10.32	M4	23
	9538	1907.6	10.87	M4	24

Note(s):

*: Measured Audio Interference level in dB (V/m): indirect method (max rms field strength Plus MIF)

** : According to the last paragraph of Section 8, the MIF measurement uncertainty is estimated to be 0.2 dB for MIF -7 to + 5 dB. The maximum E-field result of 34.78 dB V/m plus measurement uncertainty of 0.2 dB is 34.98 dB V/m, which is still within M3 rating.

11.2. Test Results for model A1429

11.2.1. Primary Antenna

Operating Mode	Ch. No.	Freq. (MHz)	Results* (dB V/m)	M-Rating	Plots Page #
CDMA BC0 1xRTT (RC3, SO55)	1013	824.7	18.39	M4	25
	384	836.5	17.95	M4	26
	777	848.31	17.82	M4	27
CDMA BC1 1xRTT (RC3, SO55)	25	1851.25	13.51	M4	28
	600	1880.0	12.95	M4	29
	1175	1908.75	12.96	M4	30
CDMA BC10 1xRTT (RC3, SO55)	476	817.9	16.30	M4	31
	580	820.5	17.11	M4	32
	684	823.1	17.77	M4	33

11.2.2. Secondary Antenna

Operating Mode	Ch. No.	Freq. (MHz)	Results* (dB V/m)	M-Rating	Plots
CDMA BC0 1xRTT (RC3, SO55)	1013	824.7	17.45	M4	34
	384	836.5	17.27	M4	35
	777	848.31	18.20	M4	36
CDMA BC1 1xRTT (RC3, SO55)	25	1851.25	11.26	M4	37
	600	1880.0	11.34	M4	38
	1175	1908.75	11.88	M4	39
CDMA BC10 1xRTT (RC3, SO55)	476	817.9	12.85	M4	40
	580	820.5	13.20	M4	41
	684	823.1	13.80	M4	42

Note(s):

*: Measured Audio Interference level in dB (V/m): indirect method (max rms field strength Plus MIF)

12. Worst-case Test Plots

E-field worst-cast test plot for Part 22, model A1428

Date: 7/2/2012

Test Laboratory: UL CCS SAR Lab C

HAC-RF Emission

Communication System: GSM-FDD (TDMA, GMSK); Frequency: 824.2 MHz; Duty Cycle: 1:8.70964

Phantom section: RF Section

DASY5 Configuration:

- Probe: ER3DV6 - SN2516; ConvF(1, 1, 1); Calibrated: 8/8/2011
- Sensor-Surface: (Fix Surface)
- Electronics: DAE4 Sn1239; Calibrated: 6/6/2012
- Phantom: HAC Test Arch with AMCC; Type: SD HAC P01 BB
- Measurement SW: DASY52, Version 52.8 (1); SEMCAD X Version 14.6.4 (4989)

GSM850/Primary Antenna_Voice_ch 128/Hearing Aid Compatibility Test (101x101x1):

Measurement grid: dx=5mm, dy=5mm

Device Reference Point: 0, 0, -6.3 mm

Reference Value = 76.27 V/m; Power Drift = -0.20 dB

Applied MIF = 3.60 dB

RF audio interference level = 40.43 dB V/m

Emission category: M3

MIF scaled E-field

Grid 1 M4 39.09 dB V/m	Grid 2 M3 40.48 dB V/m	Grid 3 M3 40.53 dB V/m
Grid 4 M4 38.46 dB V/m	Grid 5 M3 40.43 dB V/m	Grid 6 M3 40.55 dB V/m
Grid 7 M4 37.87 dB V/m	Grid 8 M3 40.01 dB V/m	Grid 9 M3 40.16 dB V/m

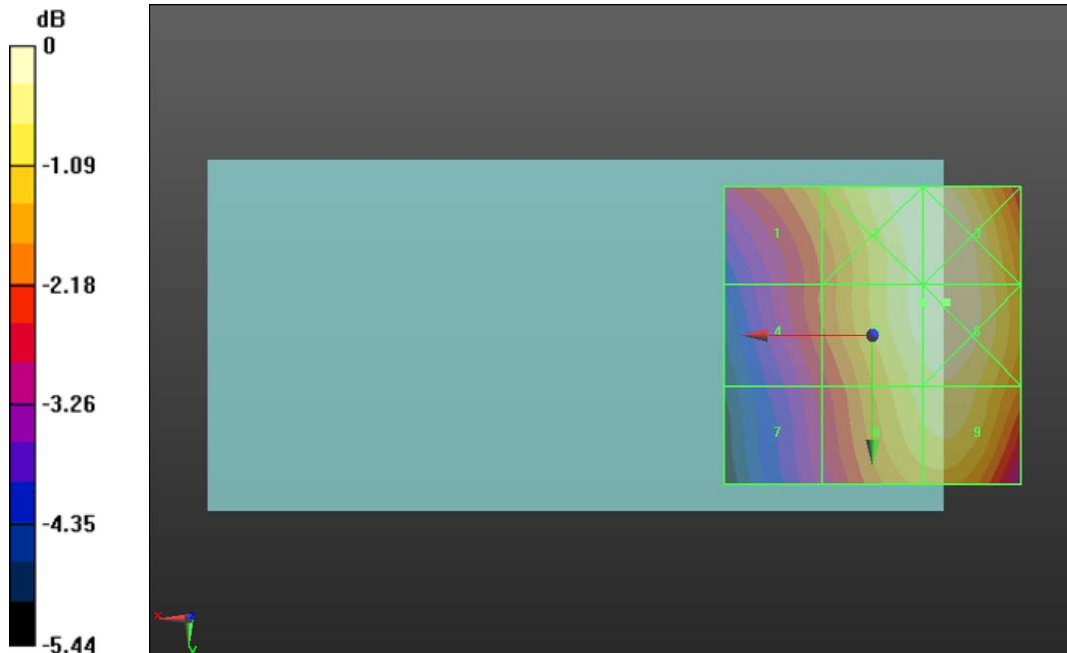

0 dB = 106.5V/m = 40.55 dB V/m

E-field worst-cast test plot for Part 24, model A1428

Date: 7/30/2012

Test Laboratory: UL CCS SAR Lab C

HAC-RF Emission

Communication System: GSM-FDD (TDMA, GMSK); Frequency: 1909.8 MHz; Duty Cycle: 1:8.70964
 Phantom section: RF Section
 DASY5 Configuration:
 - Probe: ER3DV6 - SN2516; ConvF(1, 1, 1); Calibrated: 8/8/2011
 - Sensor-Surface: (Fix Surface)
 - Electronics: DAE4 Sn1239; Calibrated: 6/6/2012
 - Phantom: HAC Test Arch with AMCC; Type: SD HAC P01 BB
 - Measurement SW: DASY52, Version 52.8 (1); SEMCAD X Version 14.6.4 (4989)

GSM1900/Secondary Antenna_Voice_ch 810/Hearing Aid Compatibility Test

(101x101x1): Measurement grid: dx=5mm, dy=5mm
 Device Reference Point: 0, 0, -6.3 mm
 Reference Value = 36.78 V/m; Power Drift = 0.02 dB
 Applied MIF = 3.60 dB
 RF audio interference level = 34.78 dB V/m

Emission category: M3

MIF scaled E-field

Grid 1 M2 35.19 dB V/m	Grid 2 M2 37.38 dB V/m	Grid 3 M2 36.83 dB V/m
Grid 4 M3 31.46 dB V/m	Grid 5 M3 34.77 dB V/m	Grid 6 M3 34.78 dB V/m
Grid 7 M3 30.5 dB V/m	Grid 8 M3 33.09 dB V/m	Grid 9 M3 33.42 dB V/m

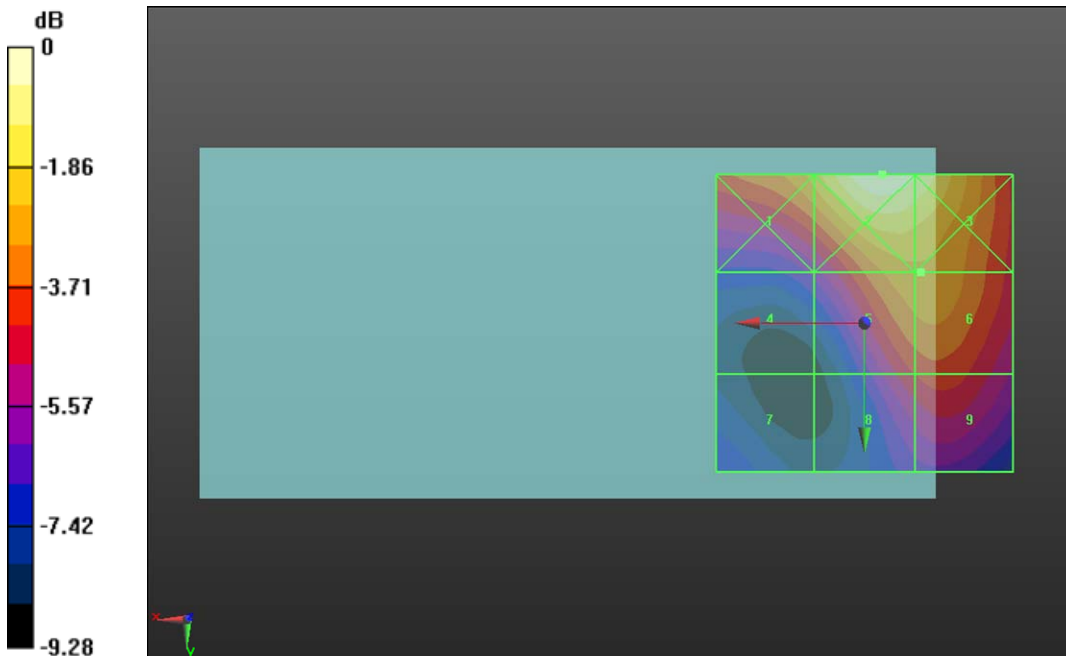

0 dB = 73.960V/m = 37.38 dB V/m

E-field worst-cast test plot for Part 22, model A1429

Date: 7/18/2012

Test Laboratory: UL CCS SAR Lab C

HAC-RF Emission

Communication System: CDMA2000 (1xRTT, RC3); Frequency: 824.7 MHz; Duty Cycle: 1:2.48886
 Phantom section: RF Section
 DASY5 Configuration:
 - Probe: ER3DV6 - SN2509; ConvF(1, 1, 1); Calibrated: 6/20/2012
 - Sensor-Surface: (Fix Surface)
 - Electronics: DAE4 Sn1239; Calibrated: 6/6/2012
 - Phantom: HAC Test Arch with AMCC; Type: SD HAC P01 BB
 - Measurement SW: DASY52, Version 52.8 (1); SEMCAD X Version 14.6.4 (4989)

CDMA BC0/Primary Antenna_RC3 SO55_ch 1013/Hearing Aid Compatibility Test

(101x101x1): Measurement grid: dx=5mm, dy=5mm
 Device Reference Point: 0, 0, -6.3 mm
 Reference Value = 89.84 V/m; Power Drift = 0.06 dB
 Applied MIF = -19.77 dB
 RF audio interference level = 18.39 dB V/m

Emission category: M4

MIF scaled E-field

Grid 1 M4 16.67 dB V/m	Grid 2 M4 18.43 dB V/m	Grid 3 M4 18.46 dB V/m
Grid 4 M4 16.11 dB V/m	Grid 5 M4 18.39 dB V/m	Grid 6 M4 18.52 dB V/m
Grid 7 M4 15.56 dB V/m	Grid 8 M4 18.1 dB V/m	Grid 9 M4 18.23 dB V/m

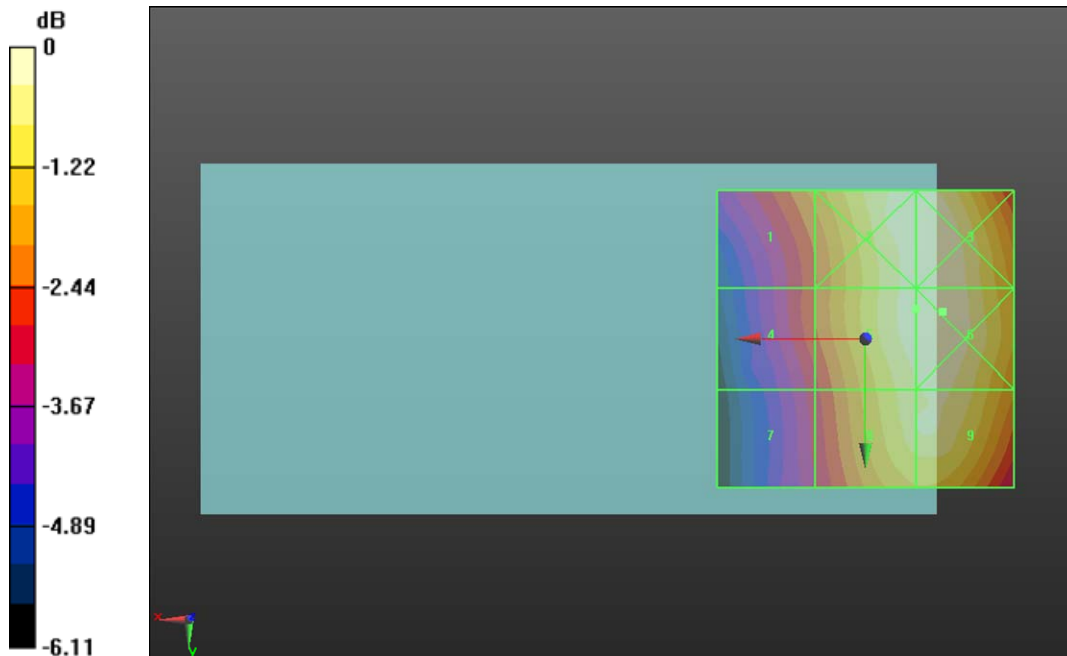

0 dB = 8.430V/m = 18.52 dB V/m

E-field worst-cast test plot for Part 24, model A1429

Date: 7/19/2012

Test Laboratory: UL CCS SAR Lab C

HAC-RF Emission

Communication System: CDMA2000 (1xRTT, RC3); Frequency: 1851.25 MHz; Duty Cycle: 1:2.48886
 Phantom section: RF Section
 DASY5 Configuration:
 - Probe: ER3DV6 - SN2509; ConvF(1, 1, 1); Calibrated: 6/20/2012
 - Sensor-Surface: (Fix Surface)
 - Electronics: DAE4 Sn1239; Calibrated: 6/6/2012
 - Phantom: HAC Test Arch with AMCC; Type: SD HAC P01 BB
 - Measurement SW: DASY52, Version 52.8 (1); SEMCAD X Version 14.6.4 (4989)

CDMA BC1/Primary Antenna_RC3 SO55_ch 25/Hearing Aid Compatibility Test

(101x101x1): Measurement grid: dx=5mm, dy=5mm
 Device Reference Point: 0, 0, -6.3 mm
 Reference Value = 46.47 V/m; Power Drift = -0.04 dB
 Applied MIF = -19.77 dB
 RF audio interference level = 13.51 dB V/m

Emission category: M4

MIF scaled E-field

Grid 1 M4 7.95 dB V/m	Grid 2 M4 12.95 dB V/m	Grid 3 M4 13.21 dB V/m
Grid 4 M4 10.23 dB V/m	Grid 5 M4 13.51 dB V/m	Grid 6 M4 13.74 dB V/m
Grid 7 M4 12.71 dB V/m	Grid 8 M4 13.7 dB V/m	Grid 9 M4 13.8 dB V/m

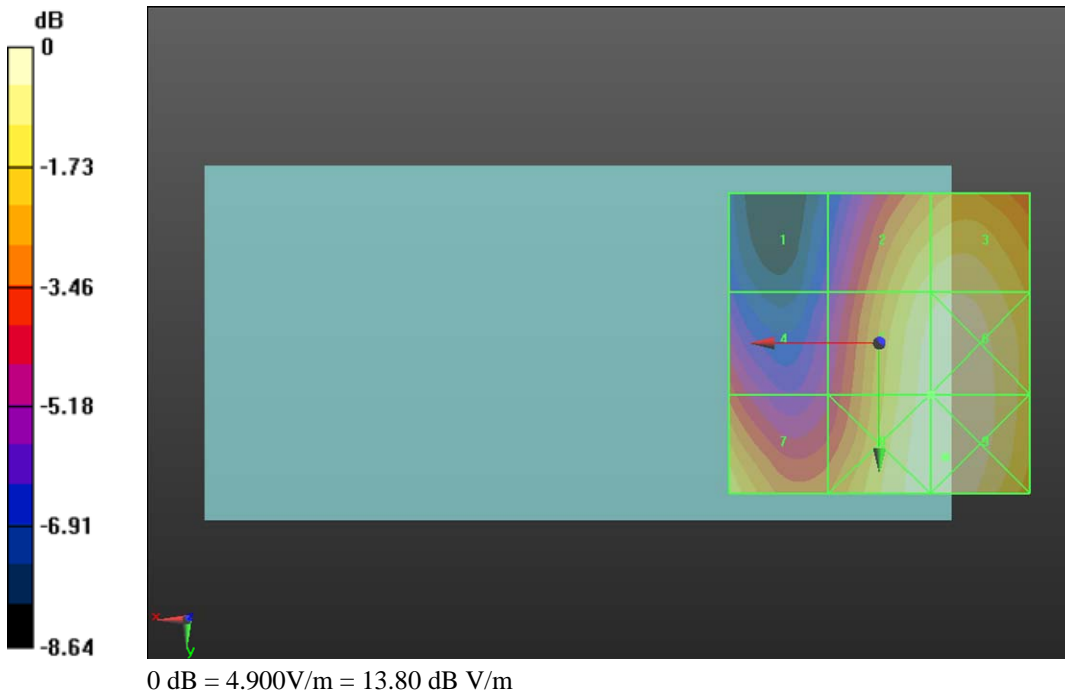

E-field worst-cast test plot for Part 90, model A1429

Date: 7/18/2012

Test Laboratory: UL CCS SAR Lab C

HAC-RF Emission

Communication System: CDMA2000 (1xRTT, RC3); Frequency: 823.1 MHz; Duty Cycle: 1:2.48886
 Phantom section: RF Section
 DASY5 Configuration:
 - Probe: ER3DV6 - SN2509; ConvF(1, 1, 1); Calibrated: 6/20/2012
 - Sensor-Surface: (Fix Surface)
 - Electronics: DAE4 Sn1239; Calibrated: 6/6/2012
 - Phantom: HAC Test Arch with AMCC; Type: SD HAC P01 BB
 - Measurement SW: DASY52, Version 52.8 (1); SEMCAD X Version 14.6.4 (4989)

CDMA BC10/Primary Antenna_RC3 SO55_ch 684/Hearing Aid Compatibility Test

(101x101x1): Measurement grid: dx=5mm, dy=5mm

Device Reference Point: 0, 0, -6.3 mm

Reference Value = 84.72 V/m; Power Drift = -0.07 dB

Applied MIF = -19.77 dB

RF audio interference level = 17.77 dB V/m

Emission category: M4

MIF scaled E-field

Grid 1 M4 16.09 dB V/m	Grid 2 M4 17.77 dB V/m	Grid 3 M4 17.87 dB V/m
Grid 4 M4 15.48 dB V/m	Grid 5 M4 17.77 dB V/m	Grid 6 M4 17.87 dB V/m
Grid 7 M4 14.94 dB V/m	Grid 8 M4 17.38 dB V/m	Grid 9 M4 17.49 dB V/m

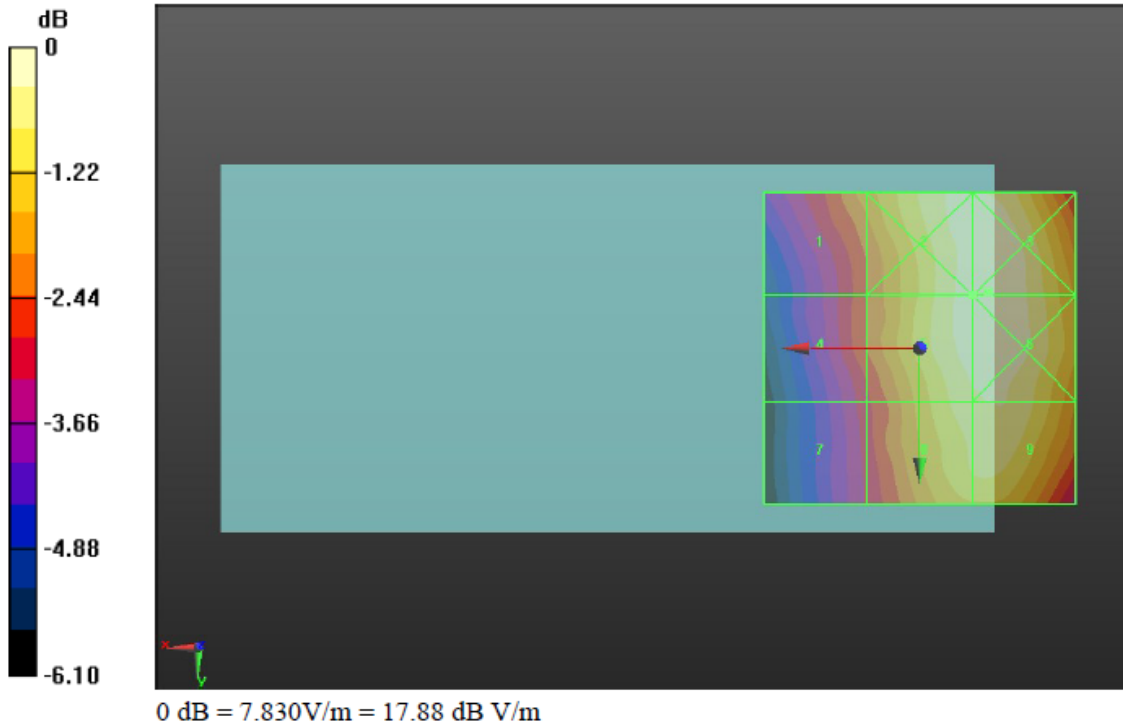

13. Appendixes

Refer to separated files for the following appendixes

- 13.1. System Validation Plots**
- 13.2. E-Field Emissions Test Plots**
- 13.3. Calibration Certificate - E-Field Probe ER3DV6 - SN 2509**
- 13.4. Calibration Certificate - E-Field Probe ER3DV6 - SN 2516**
- 13.5. Calibration Certificate for Dipole CD835V3 - SN 1175**
- 13.6. Calibration Certificate for Dipole CD1880V3 - SN 1159**
- 13.7. UID 10021 GSM Specification**
- 13.8. UID 10081 CDMA 2000 Specification**
- 13.9. UID 10011 WCDMA Specification**