



**FCC CFR47 PART 22 SUBPART H
FCC CFR47 PART 24 SUBPART E
CERTIFICATION TEST REPORT**

FOR

**Smart Cellular Telephone with CDMA 1xRTT/CDMA 1xEVDO Rev. A, Bluetooth
and WiFi 802.11 b,g,n**

MODEL NUMBER: A1349

FCC ID: BCG-E2422B

REPORT NUMBER: 10U13473-6, Revision A

ISSUE DATE: JANUARY 11, 2011

Prepared for

**APPLE
1 INFINITE LOOP
CUPERTINO, CA 95014, U.S.A.**

Prepared by

**COMPLIANCE CERTIFICATION SERVICES (UL CCS)
47173 BENICIA STREET
FREMONT, CA 94538, U.S.A.
TEL: (510) 771-1000
FAX: (510) 661-0888**



NVLAP LAB CODE 200065-0

Revision History

Rev.	Date	Revisions	Revised By
--	11/24/10	Initial Issue	T. Chan
A	1/11/11	Address TCB Questions	C. Pang

TABLE OF CONTENTS

1. ATTESTATION OF TEST RESULTS	4
2. TEST METHODOLOGY	5
3. FACILITIES AND ACCREDITATION	5
4. CALIBRATION AND UNCERTAINTY	5
4.1. <i>MEASURING INSTRUMENT CALIBRATION</i>	5
4.2. <i>SAMPLE CALCULATION</i>	5
4.3. <i>MEASUREMENT UNCERTAINTY</i>	5
5. EQUIPMENT UNDER TEST	6
5.1. <i>DESCRIPTION OF EUT</i>	6
5.2. <i>MAXIMUM OUTPUT POWER</i>	6
5.3. <i>DESCRIPTION OF AVAILABLE ANTENNAS</i>	6
5.4. <i>SOFTWARE AND FIRMWARE</i>	6
5.5. <i>WORST-CASE CONFIGURATION AND MODE</i>	7
5.6. <i>DESCRIPTION OF TEST SETUP</i>	8
6. TEST AND MEASUREMENT EQUIPMENT	11
7. RF POWER OUTPUT VERIFICATION	12
7.1. <i>RF POWER OUTPUT FOR 1xRTT</i>	13
7.2. <i>RF POWER OUTPUT FOR CDMA2000 1xEV-DO Release 0 (Rel. 0)</i>	16
7.3. <i>RF POWER OUTPUT FOR CDMA2000 1xEV-DO Revision A (Rev. A)</i>	17
8. CONDUCTED TEST RESULTS	18
8.1. <i>OCCUPIED BANDWIDTH</i>	18
8.2. <i>BAND EDGE</i>	28
8.3. <i>OUT OF BAND EMISSIONS</i>	37
8.4. <i>FREQUENCY STABILITY</i>	50
9. RADIATED TEST RESULTS	53
9.1. <i>RADIATED POWER (ERP & EIRP)</i>	53
9.2. <i>FIELD STRENGTH OF SPURIOUS RADIATION</i>	59
10. SETUP PHOTOS	64

1. ATTESTATION OF TEST RESULTS

COMPANY NAME: APPLE
1 INFINITE LOOP
CUPERTINO, CA 95014, U.S.A.

EUT DESCRIPTION: Smart Cellular Telephone with CDMA 1xRTT/CDMA 1xEVDO
Rev. A, Bluetooth and WiFi 802.11 b,g,n

MODEL: A1349

SERIAL NUMBER: C8QDF02MDHP2 (Conducted Unit),
C8QDH003DHP3 (Radiated Unit)

DATE TESTED: NOVEMBER 16-17, 2010

APPLICABLE STANDARDS	
STANDARD	TEST RESULTS
FCC PART 22H and 24E	Pass

Compliance Certification Services (UL CCS) tested the above equipment in accordance with the requirements set forth in the above standards. All indications of Pass/Fail in this report are opinions expressed by UL CCS based on interpretations and/or observations of test results. Measurement Uncertainties were not taken into account and are published for informational purposes only. The test results show that the equipment tested is capable of demonstrating compliance with the requirements as documented in this report.

Note: The results documented in this report apply only to the tested sample, under the conditions and modes of operation as described herein. This document may not be altered or revised in any way unless done so by UL CCS and all revisions are duly noted in the revisions section. Any alteration of this document not carried out by UL CCS will constitute fraud and shall nullify the document. This report must not be used by the client to claim product certification, approval, or endorsement by NVLAP, NIST, any agency of the Federal Government, or any agency of any government.

Approved & Released For UL CCS By:

Tested By:



THU CHAN
ENGINEERING MANAGER
UL CCS

CHIN PANG
EMC ENGINEER
UL CCS

2. TEST METHODOLOGY

The tests documented in this report were performed in accordance with ANSI /TIA-603-C-2004, FCC CFR 47 Part 2, and FCC CFR 47 Part 15.

3. FACILITIES AND ACCREDITATION

The test sites and measurement facilities used to collect data are located at 47173 Benicia Street, Fremont, California, USA.

UL CCS is accredited by NVLAP, Laboratory Code 200065-0. The full scope of accreditation can be viewed at <http://www.ccsemc.com>.

4. CALIBRATION AND UNCERTAINTY

4.1. MEASURING INSTRUMENT CALIBRATION

The measuring equipment utilized to perform the tests documented in this report has been calibrated in accordance with the manufacturer's recommendations, and is traceable to recognized national standards

4.2. SAMPLE CALCULATION

Where relevant, the following sample calculation is provided:

$$\text{Field Strength (dBuV/m)} = \text{Measured Voltage (dBuV)} + \text{Antenna Factor (dB/m)} + \text{Cable Loss (dB)} - \text{Preamp Gain (dB)}$$

$$36.5 \text{ dBuV} + 18.7 \text{ dB/m} + 0.6 \text{ dB} - 26.9 \text{ dB} = 28.9 \text{ dBuV/m}$$

4.3. MEASUREMENT UNCERTAINTY

Where relevant, the following measurement uncertainty levels have been estimated for tests performed on the apparatus:

PARAMETER	UNCERTAINTY
Conducted Disturbance, 0.15 to 30 MHz	3.52 dB
Radiated Disturbance, 30 to 1000 MHz	4.94 dB

Uncertainty figures are valid to a confidence level of 95%.

5. EQUIPMENT UNDER TEST

5.1. DESCRIPTION OF EUT

The Apple iPhone, Model A1349 is a smart phone with iPod functions (music, application support, and video), CDMA 1xRTT/CDMA 1xEVDO Release A, 802.11b/g/n, and Bluetooth 2.1+EDR. This device measures 115.2 mm (4.5 inches) tall x 58.6 mm (2.31 inches) and 9.3 mm (0.37 inches) thick and weighs 137 grams (4.8 oz.) The rechargeable battery is not user accessible.

The WLAN module is manufactured by Semco.

5.2. MAXIMUM OUTPUT POWER

The transmitter has a maximum output power as follows:

Part 22 Cellular Band

Frequency range (MHz)	Modulation	Conducted		ERP	
		dBm	mW	dBm	mW
824.7 – 848.31	1xRTT (RC2, SO9)	28.95	785.2	26.2	416.9
824.7 – 848.31	EV-DO - REV A	29.60	912.0	27.9	616.6

Part 24 PCS Band

Frequency range (MHz)	Modulation	Conducted		EIRP	
		dBm	mW	dBm	mW
1851.25 – 1908.8	1xRTT (RC2, SO9)	27.30	537.0	26.9	489.8
1851.25 – 1908.8	EV-DO - REV A	27.80	602.6	28.1	645.7

5.3. DESCRIPTION OF AVAILABLE ANTENNAS

The radio utilizes an integral antenna for the 850MHz and 1900MHz bands with a maximum peak gain of 0.16 dBi for cell band and 1.69 dBi for PCS band.

5.4. SOFTWARE AND FIRMWARE

The firmware installed in the EUT during testing was 0.6.13_21

The EUT software installed during testing was 8E5074b

The EUT is linked with Agilent 8960 Communication Test Set.

5.5. WORST-CASE CONFIGURATION AND MODE

The worst-case channel for RF radiated emissions below 1GHz and AC conducted emissions are determined as the channel with the AC Power Adapter Source

Based on the investigation results, the highest peak power and enhanced data rate is the worst-case scenario for all measurements.

Worst case modes:

- For Cellular and PCS band: 1xRTT (RC2 SO9)
- For Cellular and PCS band: CDMA2000 1xEV-DO Revision A (Rev. A)

The worst-case configuration has been evaluated on EUT with antenna @ Z-position for both 850MHz and 1900MHz bands by comparing the fundamental ERP / EIRP output power.

5.6. DESCRIPTION OF TEST SETUP

I/O CABLES (RF CONDUCTED TEST)

I/O CABLE LIST						
Cable No.	Port	# of Identical Ports	Connector Type	Cable Type	Cable Length	Remarks
1	AC	1	US 115V	Un-shielded	2m	NA
2	DC	1	DC	Un-shielded	2m	NA
3	Directional	1	Spectrum Analyzer	Un-shielded	1m	NA
4	RF In/Out	1	Communications Test Set	Un-shielded	1m	NA
5	Directional	1	EUT	Un-shielded	NA	NA

I/O CABLES (RF RADIATED TEST)

I/O CABLE LIST						
Cable No.	Port	# of Identical Ports	Connector Type	Cable Type	Cable Length	Remarks
1	AC	1	US 115V	Un-shielded	2m	NA
2	DC	1	DC	Un-shielded	2m	NA
3	RF In/Out	1	Horn	Un-shielded	1m	NA

SUPPORT EQUIPMENT

PERIPHERAL SUPPORT EQUIPMENT LIST				
Description	Manufacturer	Model	Serial Number	FCC ID
AC Adapter	Apple	A1205	1X009142X8QZ	DoC
Earphone	Apple	MB770	NA	NA

TEST SETUP

The EUT is a stand-alone device. The Wireless Communication test set exercised the EUT.

SETUP DIAGRAM FOR RF CONDUCTED TESTS

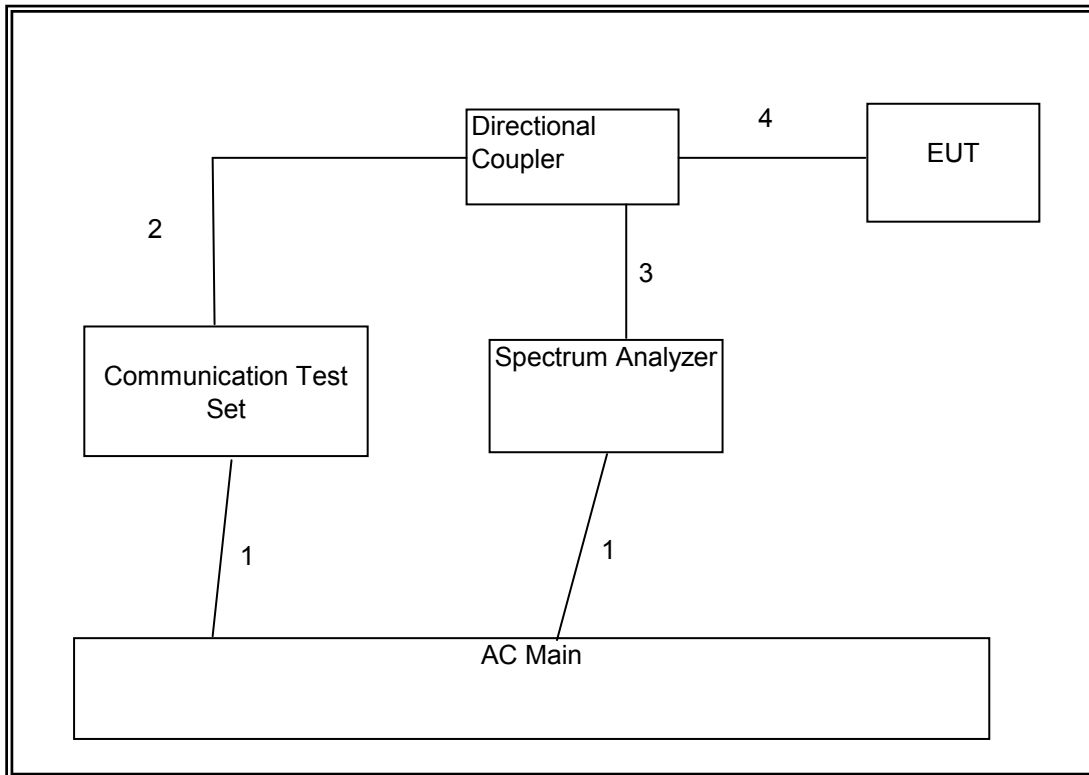

SETUP DIAGRAM FOR RF RADIATED TESTS (Standard Backcover)

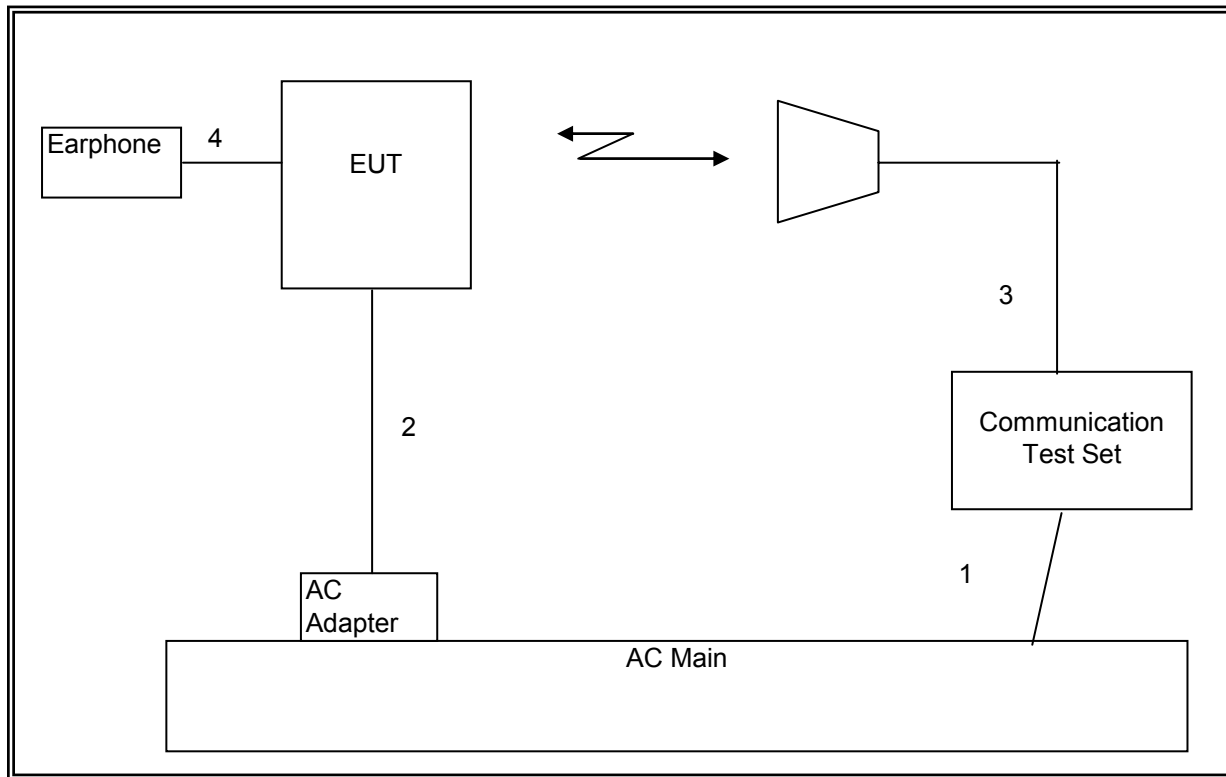

6. TEST AND MEASUREMENT EQUIPMENT

The following test and measurement equipment was utilized for the tests documented in this report:

TEST EQUIPMENT LIST				
Description	Manufacturer	Model	Asset	Cal Due
Spectrum Analyzer, 44 GHz	Agilent / HP	E4446A	C01159	05/08/11
Antenna, Horn, 18 GHz	EMCO	3115	C00872	06/29/11
Preamplifier, 1300 MHz	Agilent / HP	8447D	C00885	01/06/11
Preamplifier, 26.5 GHz	Agilent / HP	8449B	C01063	07/14/11
EMI Test Receiver, 30 MHz	R & S	ESHS 20	N02396	05/06/11
Communication Test Set	Agilent / HP	E5515C	C01086	06/17/11
LISN, 30 MHz	FCC	LISN-50/250-25-2	N02625	11/10/11
Temperature / Humidity Chamber	Thermotron	SE 600-10-10	C00930	04/11/11
Highpass Filter, 1.5 GHz	Micro-Tronics	HPM13193	N02689	CNR
Highpass Filter, 2.7 GHz	Micro-Tronics	HPM13194	N02687	CNR
Directional Coupler, 18 GHz	Krytar	1817	N02656	CNR
Signal Generator, 20 GHz	Agilent / HP	83732B	C00774	07/14/12
Antenna, Tuned Dipole 400~1000 MHz	ETS	3121C DB4	C00993	06/28/11

7. RF POWER OUTPUT VERIFICATION

Maximum output power is verified on the Low, Middle and High channels according to procedures in section 4.4.5.2 of 3GPP2 C.S0011/TIA-98-E for 1xRTT, section 3.1.2.3.4 of 3GPP2 C.S0033-0/TIA-866 for Rel. 0 and section 4.3.4 of 3GPP2 C.S0033-A for Rev. A

CELL, CDMA200, EVDO REV A

Data Rate	PK (dBm)
128	28.32
256	28.30
512	28.46
768	28.46
1024	28.48
1536	28.48
2048	28.44
3072	28.62
4096	28.76
6144	28.69
8192	28.65
12288	28.64

PCS, CDMA200, EVDO REV A

Data Rate	PeaK
128	27.68
256	27.60
512	27.65
768	27.65
1024	27.60
1536	27.60
2048	27.75
3072	27.75
4096	27.80
6144	27.70
8192	27.70
12288	27.69

7.1. RF POWER OUTPUT FOR 1xRTT

This procedure assumes the Agilent 8960 Test Set has the following applications installed and with valid license.

<u>Application</u>	<u>Rev, License</u>
CDMA2000 Mobile Test	B.13.08, L

- Call Setup > Shift & Preset
- Cell Info > Cell Parameters > System ID (SID) > 8
> Network ID (NID) > 65535
- Protocol Rev > 6 (IS-2000-0)
- Radio Config (RC) > Please see following table or details
- FCH Service Option (SO) Setup > Please see following table or details
- Traffic Data Rate > Full
- TDSO SCH Info > F-SCH Parameters > F-SCH Data Rate > 153.6 kbps
> R-SCH Parameters > R-SCH Data Rate > 153.6 kbps
- Rvs Power Ctrl > Active bits
 - Rvs Power Ctrl > All Up bits (Maximum TxPout)

RF Power Output Results for 1XRTT

RF Power Output for 1xRTT - Cell Band							
Radio Configuration (RC)	Service Option (SO)	Conducted Output Power (dBm)					
		Ch. 1013/824.7MHz		Ch. 384/836.52MHz		Ch. 777/848.31MHz	
		Average	Peak	Average	Peak	Average	Peak
RC1 (Fwd1, Rvs1)	1 (Voice)		n/a		n/a		n/a
	2 (Loopback)		28.05		28.45		28.78
	3 (Voice)		n/a		n/a		n/a
	55 (Loopback)		28.02		28.40		28.82
	68 (Voice)		n/a		n/a		n/a
RC2 (Fwd2, Rvs2)	9 (Loopback)		28.31		28.40		28.95
	17 (Voice)		n/a		n/a		n/a
	55 (Loopback)		28.0		28.50		28.90
	32768 (Voice)		n/a		n/a		n/a
RC3 (Fwd3, Rvs3)	1 (Voice)		n/a		n/a		n/a
	2 (Loopback)		27.80		28.00		28.35
	3 (Voice)		n/a		n/a		n/a
	55 (Loopback)		27.85		28.12		28.40
	32 (+ F-SCH)		27.15		27.18		27.15
	32 (+ SCH)		26.78		27.10		27.13
RC4 (Fwd4, Rvs3)	68 (Voice)		n/a		n/a		n/a
	1 (Voice)		n/a		n/a		n/a
	2 (Loopback)		27.85		28.12		28.35
	3 (Voice)		n/a		n/a		n/a
	55 (Loopback)		27.70		28.00		28.36
	32 (+ F-SCH)		27.55		27.76		27.85
	32 (+ SCH)		27.80		27.70		27.80
RC5 (Fwd5, Rvs4)	68 (Voice)		n/a		n/a		n/a
	9 (Loopback)		27.85		28.12		28.30
	17 (Voice)		n/a		n/a		n/a
	55 (Loopback)		27.80		28.14		28.35
	32768 (Voice)		n/a		n/a		n/a

RF Power Output Results for 1XRTT

RF Power Output for 1xRTT - PCS Band							
Radio Configuration (RC)	Service Option (SO)	Conducted Output Power (dBm)					
		Ch. 25/1851.25MHz		Ch. 600/1880MHz		Ch. 1175/1908.75 MHz	
		Average	Peak	Average	Peak	Average	Peak
RC1 (Fwd1, Rvs1)	1 (Voice)		n/a		n/a		n/a
	2 (Loopback)		27.15		27.22		26.27
	3 (Voice)		n/a		n/a		n/a
	55 (Loopback)		27.15		27.15		26.3
	68 (Voice)		n/a		n/a		n/a
RC2 (Fwd2, Rvs2)	9 (Loopback)		27.18		27.30		26.3
	17 (Voice)		n/a		n/a		n/a
	55 (Loopback)		27.22		27.16		26.1
	32768 (Voice)		n/a		n/a		n/a
RC3 (Fwd3, Rvs3)	1 (Voice)		n/a		n/a		n/a
	2 (Loopback)		26.95		26.80		26.1
	3 (Voice)		n/a		n/a		n/a
	55 (Loopback)		27		26.87		26
	32 (+ F-SCH)		27.2		27.10		27.30
	32 (+ SCH)		27		27.00		27.15
RC4 (Fwd4, Rvs3)	68 (Voice)		n/a		n/a		n/a
	1 (Voice)		n/a		n/a		n/a
	2 (Loopback)		26.75		26.15		26.14
	3 (Voice)		n/a		n/a		n/a
	55 (Loopback)		26.75		26.90		26.2
	32 (+ F-SCH)		27.12		27.05		27.10
	32 (+ SCH)		27		27.05		27.10
RC5 (Fwd5, Rvs4)	68 (Voice)		n/a		n/a		n/a
	9 (Loopback)		26.85		26.90		26.22
	17 (Voice)		n/a		n/a		n/a
	55 (Loopback)		26.70		26.80		26.1
	32768 (Voice)		n/a		n/a		n/a

7.2. RF POWER OUTPUT FOR CDMA2000 1xEV-DO Release 0 (Rel. 0)

This procedure assumes the Agilent 8960 Test Set has the following applications installed and with valid license.

<u>Application</u>	<u>Rev, License</u>
1xEV-DO Terminal Test	A.09.13

EVDO Release 0 - RTAP

- Call Setup > Shift & Preset
- Call Control:
 - Access Network Info > Cell Parameters > Sector ID > 00000000 > Subnet Mask > 0
 - Generator Info > Termination Parameters > Max Forward Packet Duration > 16 Slots
- Call Params:
 - Cell Power > -105.5 dBm/1.23 MHz
 - Cell Band > (Select US Cellular or US PCS)
 - Channel > (Enter channel number)
 - Application Config > Enhanced Test Application Protocol > RTAP
 - RTAP Rate > 153.6 kbps
 - Rvs Power Ctrl > Active bits
 - Protocol Rel > 0 (1xEV-DO)
- Press "Start Data Connection" when "Session Open" appear in "Active Cell"
- Rvs Power Ctrl > All Up bits (Maximum TxPout)

EVDO Release 0 - FTAP

- Call Setup > Shift & Preset
- Call Control:
 - Access Network Info > Cell Parameters > Sector ID > 00000000 > Subnet Mask > 0
 - Generator Info > Termination Parameters > Max Forward Packet Duration > 16 Slots
- Call Params:
 - Cell Power > -105.5 dBm/1.23 MHz
 - Cell Band > (Select US Cellular or US PCS)
 - Channel > (Enter channel number)
 - Application Config > Enhanced Test Application Protocol > FTAP (default)
 - FTAP Rate > 307.2 kbps (2 Slot, QPSK)
 - Rvs Power Ctrl > Active bits
 - Protocol Rel > 0 (1xEV-DO)
- Press "Start Data Connection" when "Session Open" appear in "Active Cell"
- Rvs Power Ctrl > All Up bits (Maximum TxPout)

RF Power Output for CDMA2000 1xEV-DO Release 0 (Rel. 0)

Cell Band

FTAP Rate	RTAP Rate	Channel	f (MHz)	Conducted power (dBm)	
				Average	Peak
307.2 kbps (2 slot, QPSK)	153.6 kbps	1013	824.70		28.36
		384	836.52		28.34
		777	848.31		28.59

PCS Band

FTAP Rate	RTAP Rate	Channel	f (MHz)	Conducted power (dBm)	
				Average	Peak
307.2 kbps (2 slot, QPSK)	153.6 kbps	25	1851.25		27.54
		600	1880.00		27.47
		1175	1908.75		27.79

7.3. RF POWER OUTPUT FOR CDMA2000 1xEV-DO Revision A (Rev. A)

This procedure assumes the Agilest 8960 Test Set has the following applications installed and with valid license.

Application	Rev, License
1xEV-DO Terminal Test	A.09.13

EVDO Release A – RETAP

- Call Setup > Shift & Preset
- Cell Power > -60 dBm/1.23 MHz
- Protocol Rev > A (1xEV-DO-A)
- Application Config > Enhanced Test Application Protocol > RETAP
- R-Data Pkt Size > 4096
- Protocol Subtype Config > Release A Physical Layer Subtype > Subtype 2
- > PL Subtype 2 Access Channel MAC Subtype > Default (Subtype 0)
- Access Network Info > Cell Parameters > Sector ID > 00000000 > Subnet Mask > 0
- Generator Info > Termination Parameters > Max Forward Packet Duration >16 Slots > ACK R-Data After > Subpacket 0 (All ACK)
- Rvs Power Ctrl > All Up bits (to get the maximum power)

EVDO Release A - FETAP

- Call Setup > Shift & Preset
- Cell Power > -60 dBm/1.23 MHz
- Protocol Rev > A (1xEV-DO-A)
- Application Config > Enhanced Test Application Protocol > FETAP
- F-Traffic Format > 4 (1024, 2,128) Canonical (307.2k, QPSK)
- Protocol Subtype Config > Release A Physical Layer Subtype > Subtype 2
- > PL Subtype 2 Access Channel MAC Subtype > Default (Subtype 0)
- Access Network Info > Cell Parameters > Sector ID > 00000000 > Subnet Mask > 0
- Generator Info > Termination Parameters > Max Forward Packet Duration >16 Slots > ACK R-Data After > Subpacket 0 (All ACK)
- Rvs Power Ctrl > All Up bits (to get the maximum power)

RF Power Output Results for CDMA2000 1xEV-DO Revision A (Rev. A)

Cell Band

FETAP-Traffic Format	RETAP-Data Payload Size	Channel	f (MHz)	Conducted power (dBm)	
				Average	Peak
307.2k, QPSK/ ACK channel is transmitted at all the slots	4096	1013	824.70		28.98
		384	836.52		28.76
		777	848.31		29.60

PCS Band

FETAP-Traffic Format	RETAP-Data Payload Size	Channel	f (MHz)	Conducted power (dBm)	
				Average	Peak
307.2k, QPSK/ ACK channel is transmitted at all the slots	4096	25	1851.25		27.63
		600	1880.00		27.80
		1175	1908.75		27.73

8. CONDUCTED TEST RESULTS

8.1. OCCUPIED BANDWIDTH

RULE PART(S)

FCC: §2.1049
 IC: RSS-Gen, 4.6

LIMITS

For reporting purposes only

TEST PROCEDURE

The transmitter output was connected to a calibrated coaxial cable and coupler, the other end of which was connected to a spectrum analyzer. The occupied bandwidth was measured with the spectrum analyzer at the low, middle and high channel in each band. The -26dB bandwidth was also measured and recorded.

MODES TESTED

- 1xRTT – RC2, SO9
- CDMA2000 1xEV-DO Revision A (Rev. A)

RESULTS

Band	Mode	Channel	f (MHz)	99% BW (MHz)	-26dB BW MHz)
Cellular	1xRTT	1013	824.70	1.2681	1.381
		384	836.52	1.2700	1.411
		777	848.31	1.2747	1.384
	CDMA2000 1xEV-DO Revision A (Rev. A)	1013	824.70	1.2628	1.381
		384	836.52	1.2714	1.385
		777	848.31	1.2817	1.409
PCS	1xRTT	25	1851.25	1.2723	1.365
		600	1880.0	1.2749	1.417
		1175	1908.75	1.2783	1.392
	CDMA2000 1xEV-DO Revision A (Rev. A)	25	1851.25	1.2732	1.367
		600	1880.0	1.2706	1.409
		1175	1908.75	1.2731	1.416

CDMA2000 1xRTT Mode (Cellular Band)

99% BANDWIDTH and 26dB

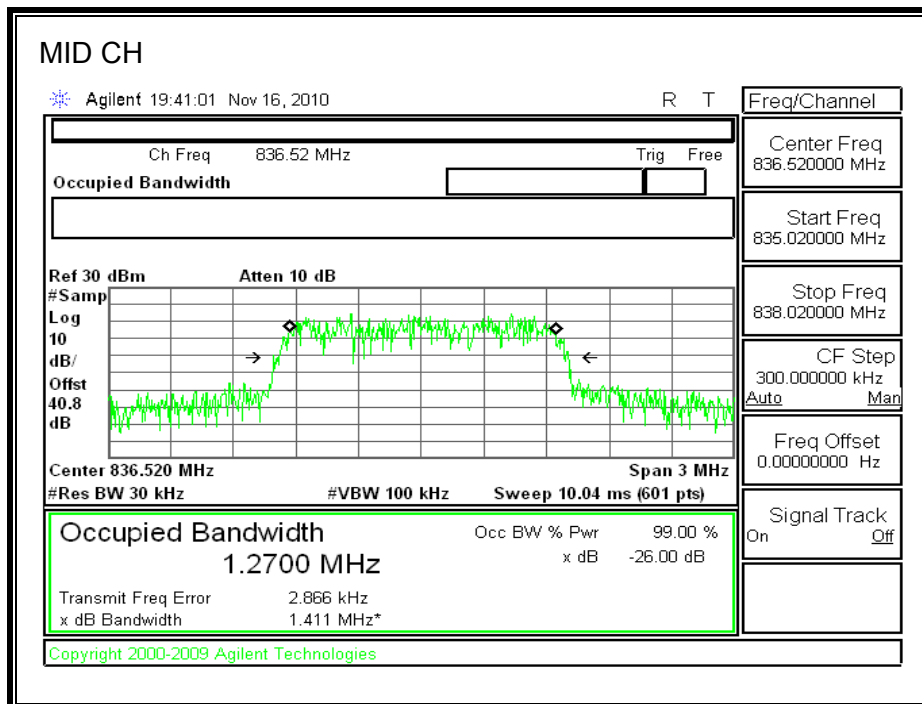
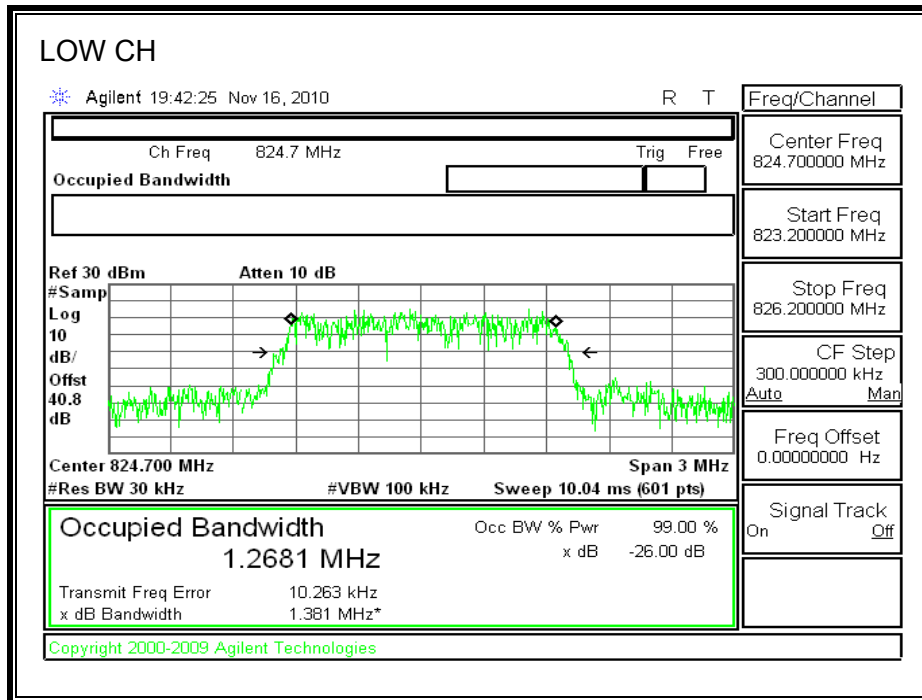

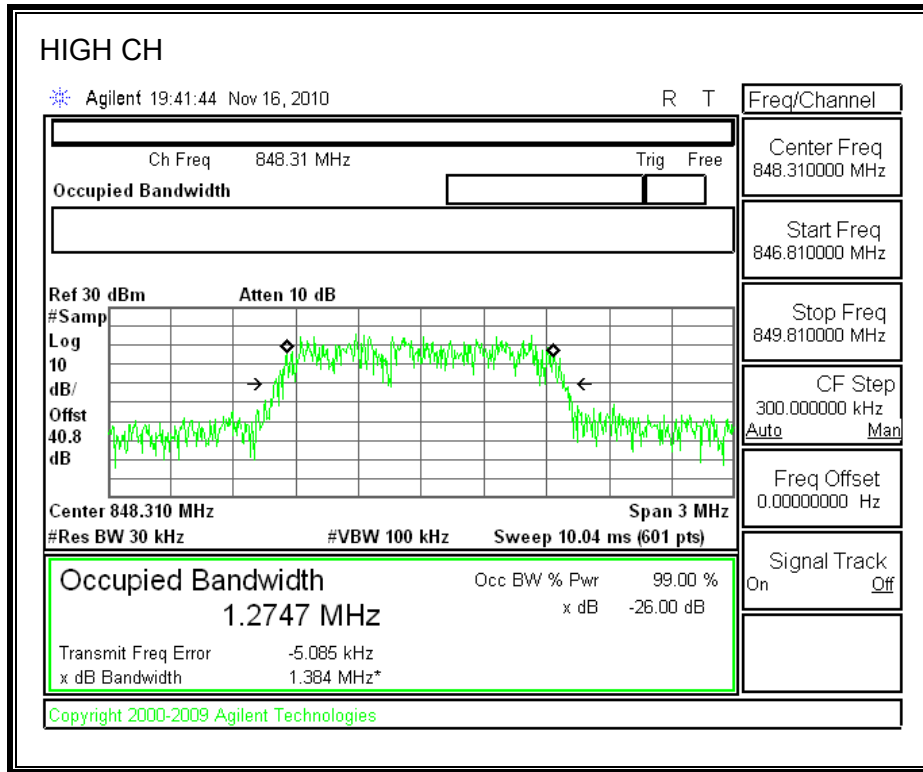

CDMA2000 1xEV-DO Revision A (Rev. A) Cellular Band

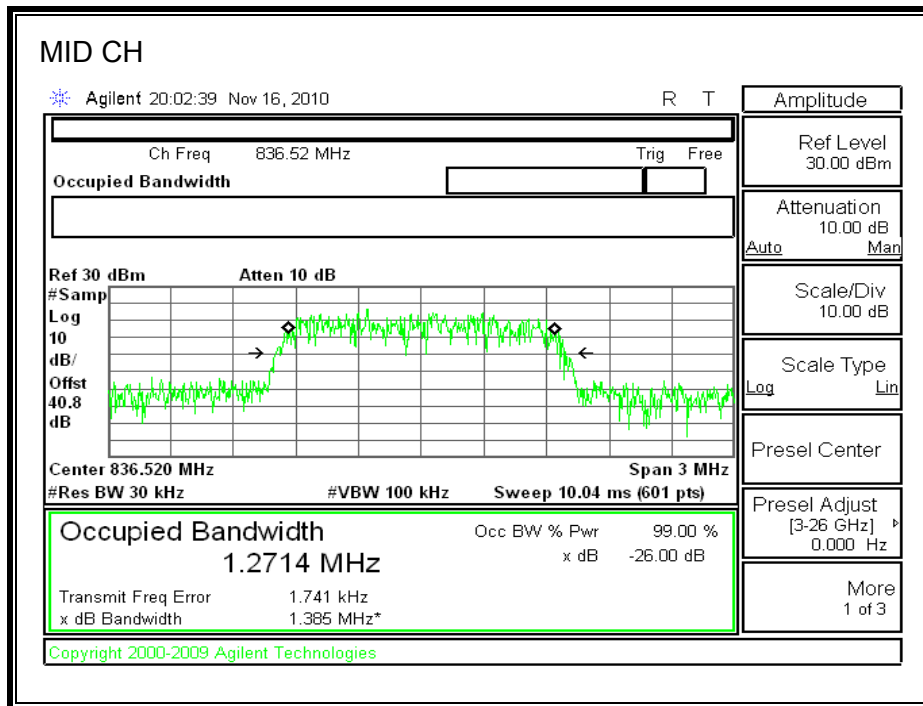
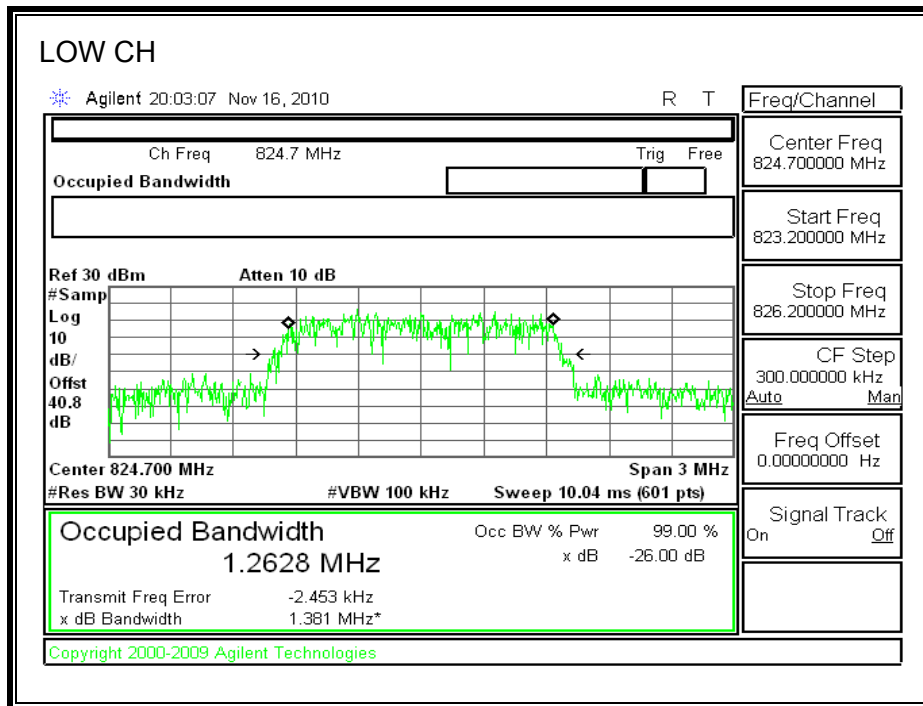

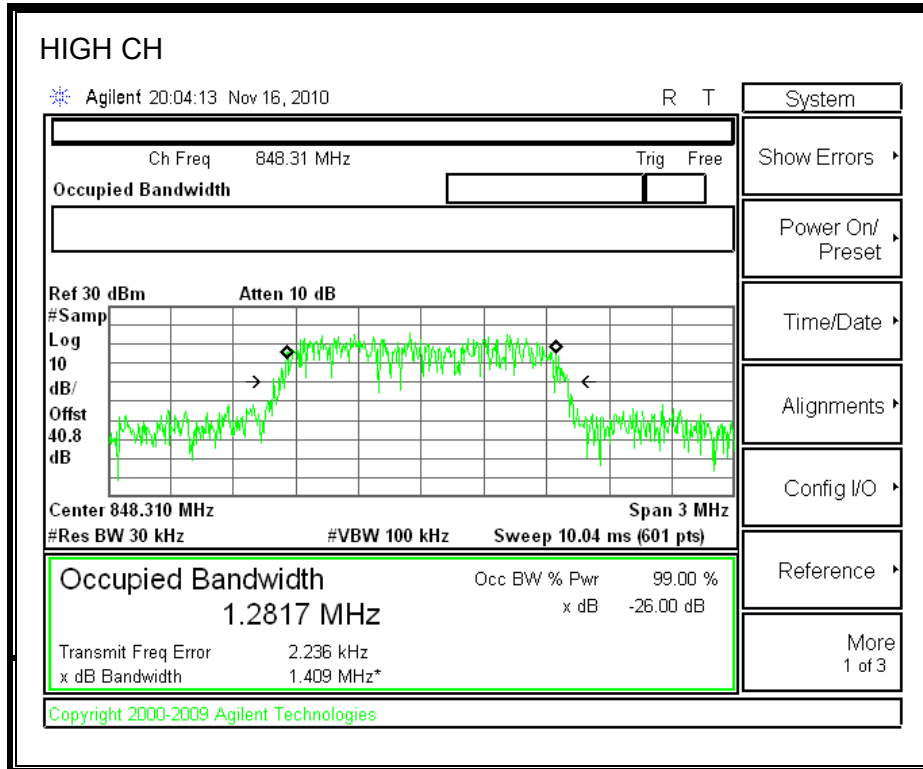

CDMA2000 1xRTT Mode (PCS Band)

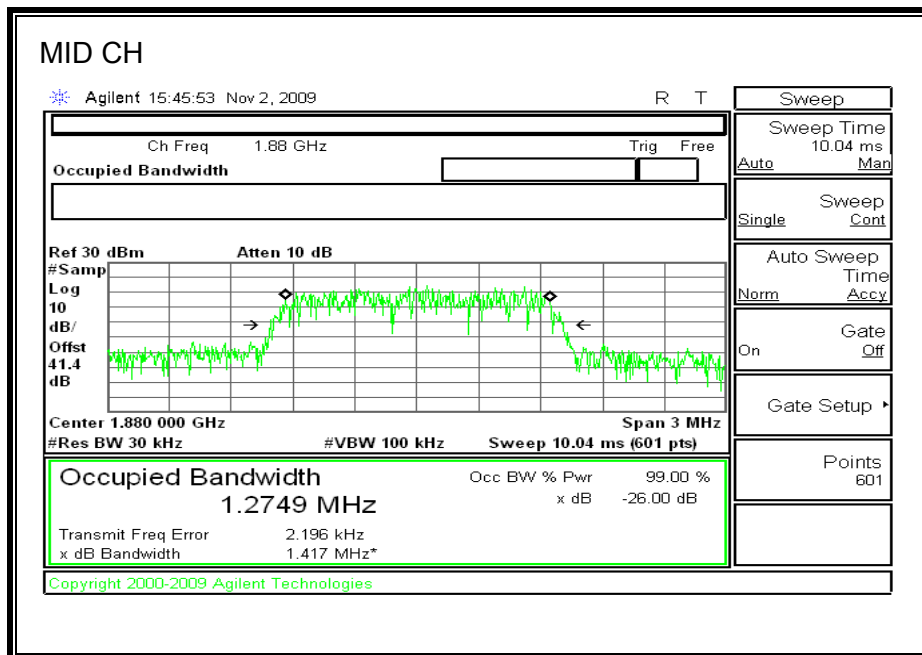
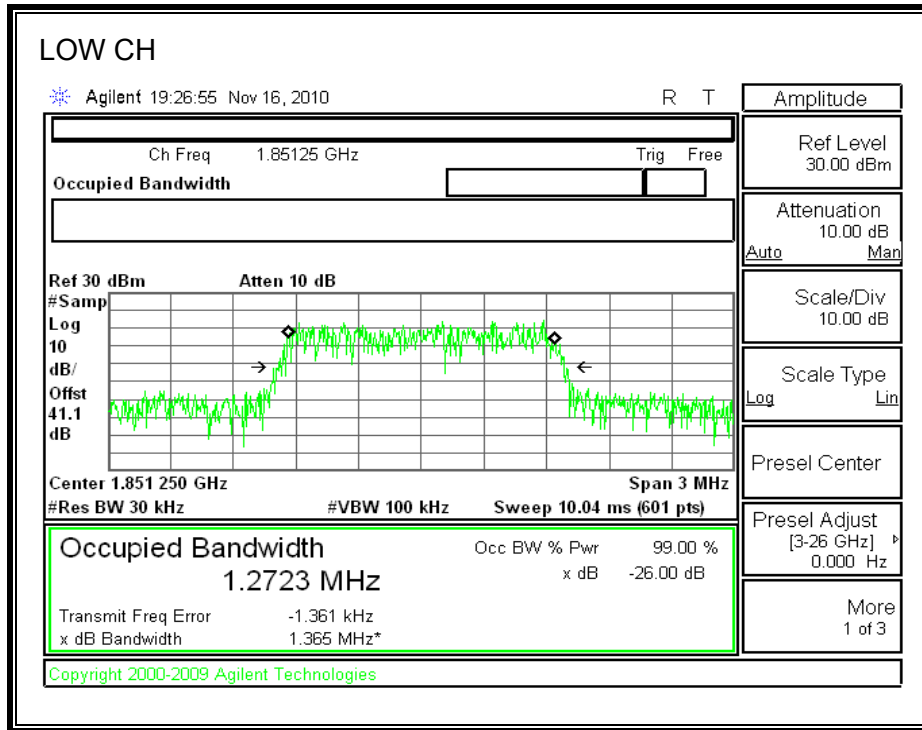

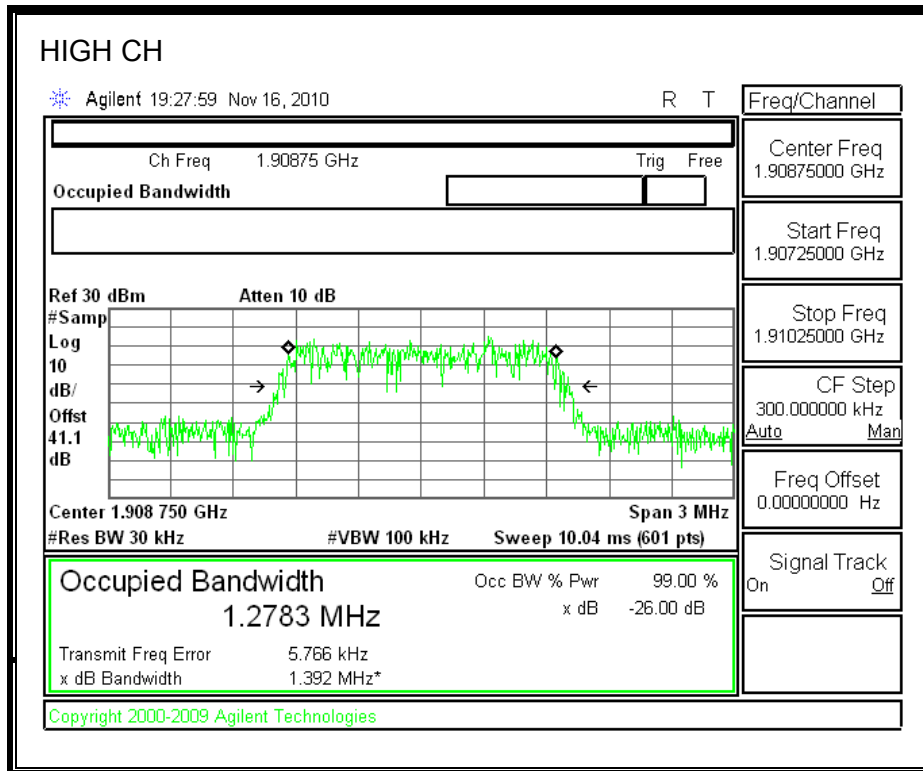

CDMA2000 1xEV-DO Revision A (Rev. A) Mode (PCS Band)

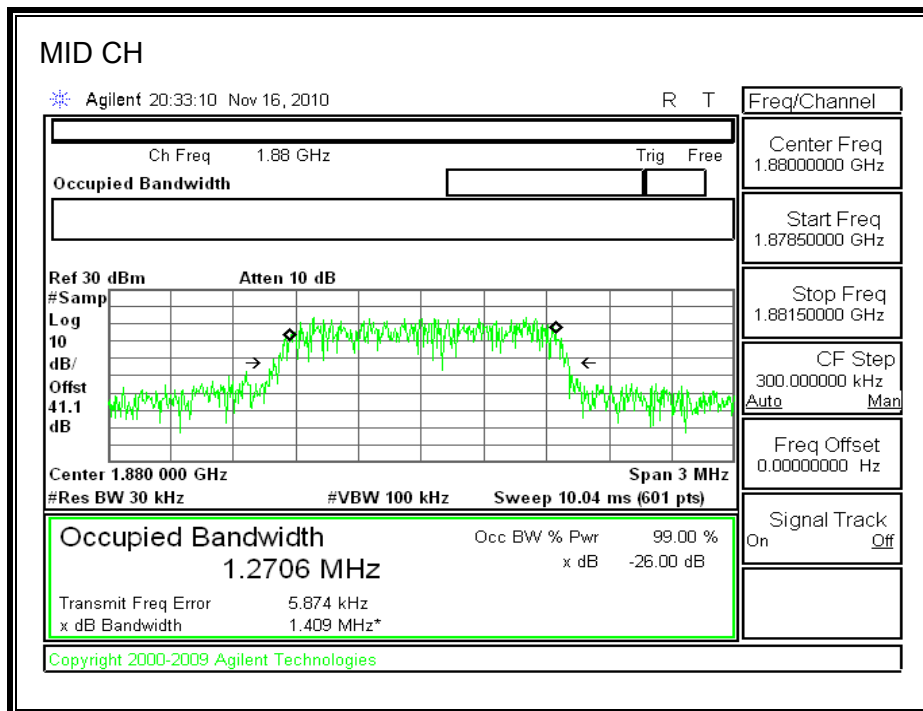
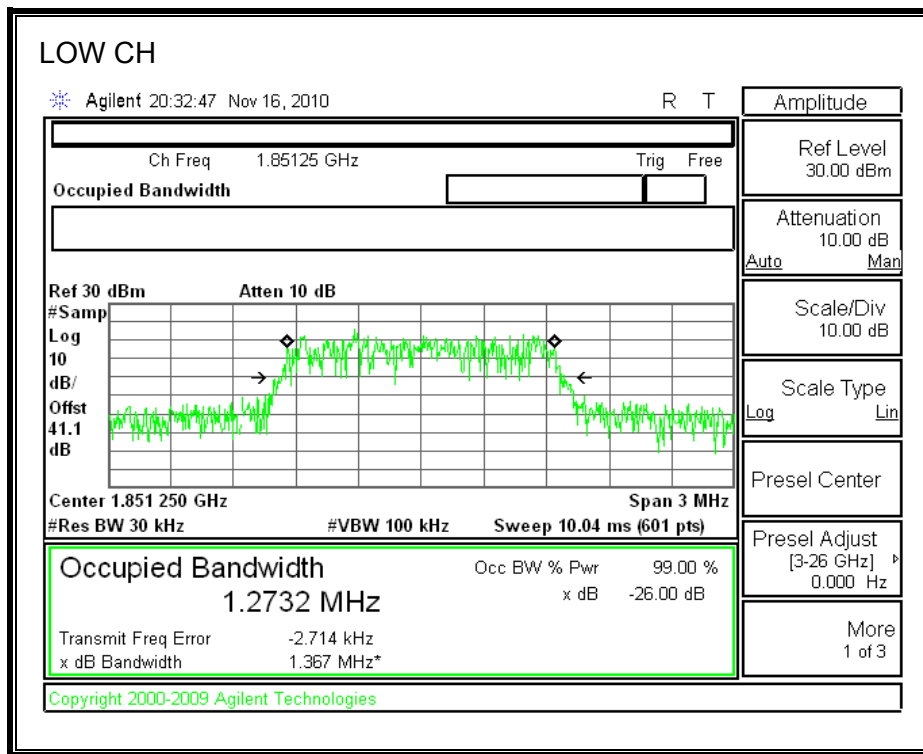

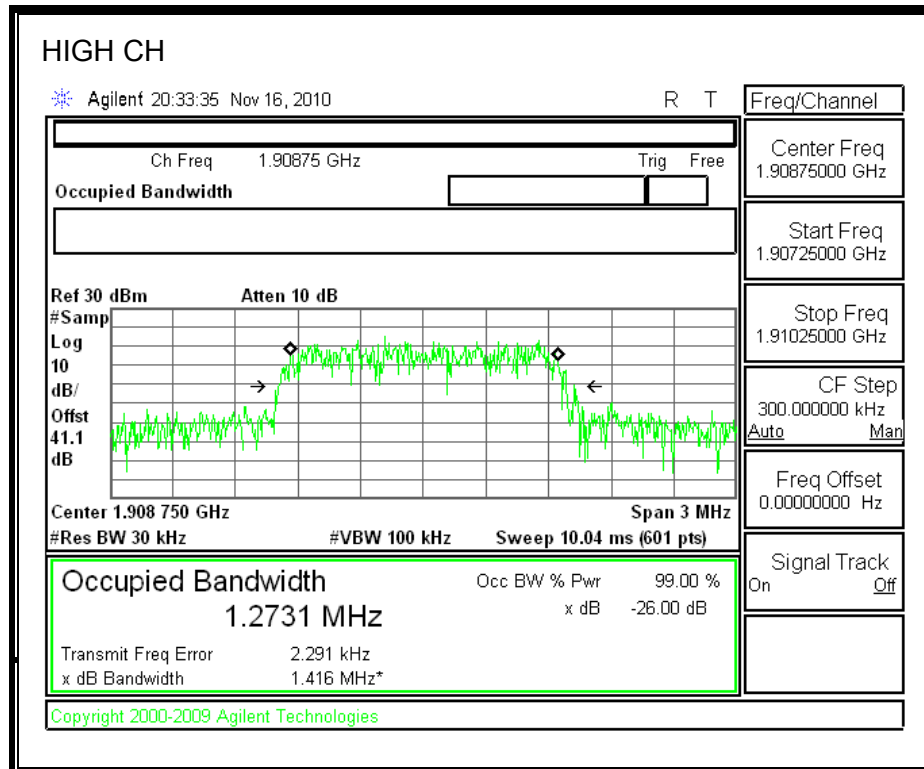

8.2. BAND EDGE

RULE PART(S)

FCC: §22.359, 24.238

IC: RSS-132, 4.5; RSS-133, 6.5

LIMITS

The power of any emission outside of the authorized operating frequency ranges must be attenuated below the transmitting power (P) by a factor of at least $43 + 10 \log (P)$ dB.

TEST PROCEDURE

The transmitter output was connected to a Agilent 8960 Test Set and configured to operate at maximum power. The band edge emissions were measured at the required operating frequencies in each band on the Spectrum Analyzer.

For each band edge measurement:

- Set the spectrum analyzer span to include the block edge frequency (824, 848, 1850, 1910MHz)
- Set a marker to point the corresponding band edge frequency in each test case.
- Set display line at -13 dBm
- Set resolution bandwidth to at least 1% of emission bandwidth.

MODES TESTED

- 1xRTT – RC2, SO9
- CDMA2000 1xEV-DO Revision A (Rev. A)

RESULTS

CDMA2000 1xRTT mode (Cellular Band)

Low Channel Band Edge

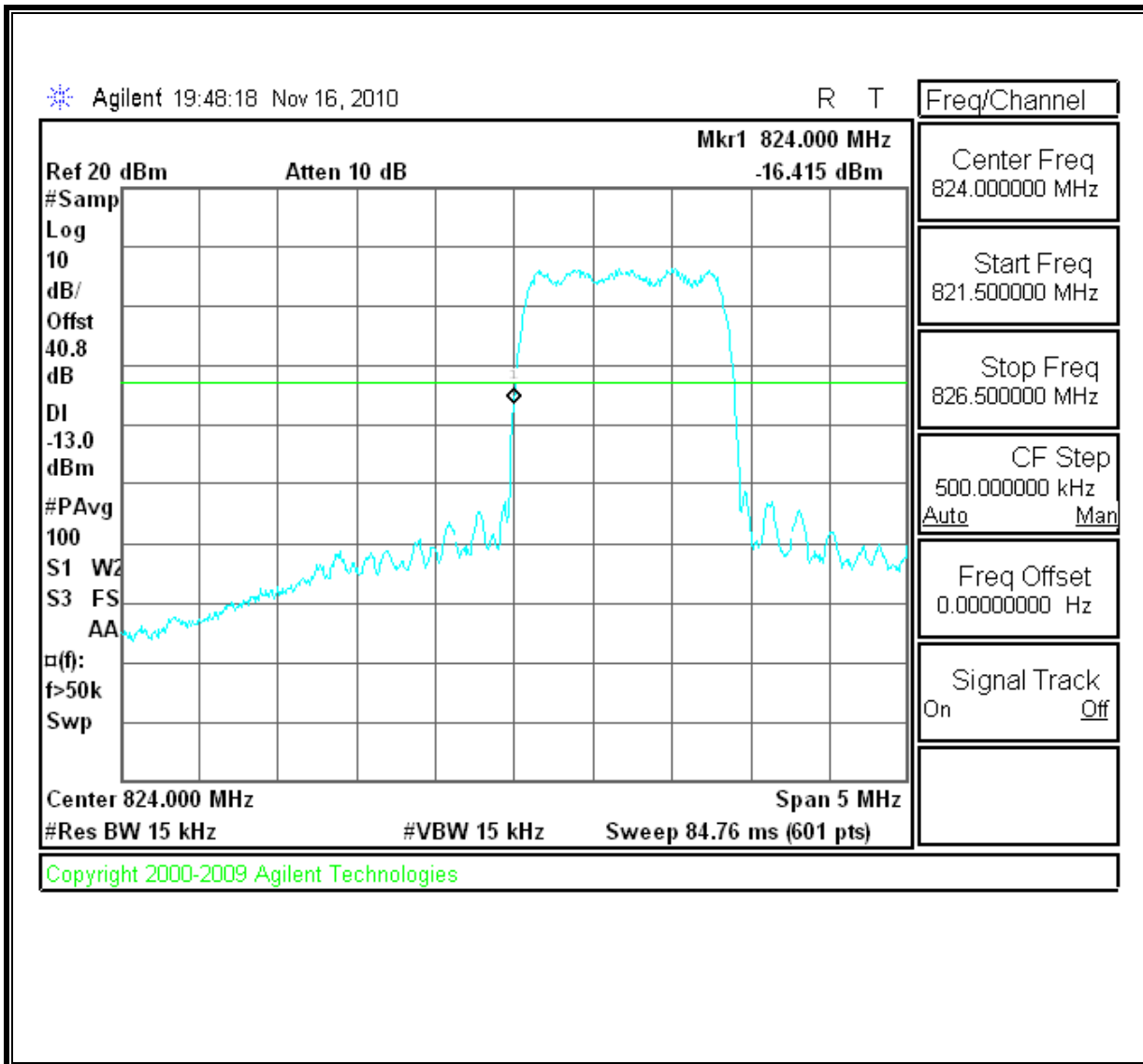

High Channel Band Edge

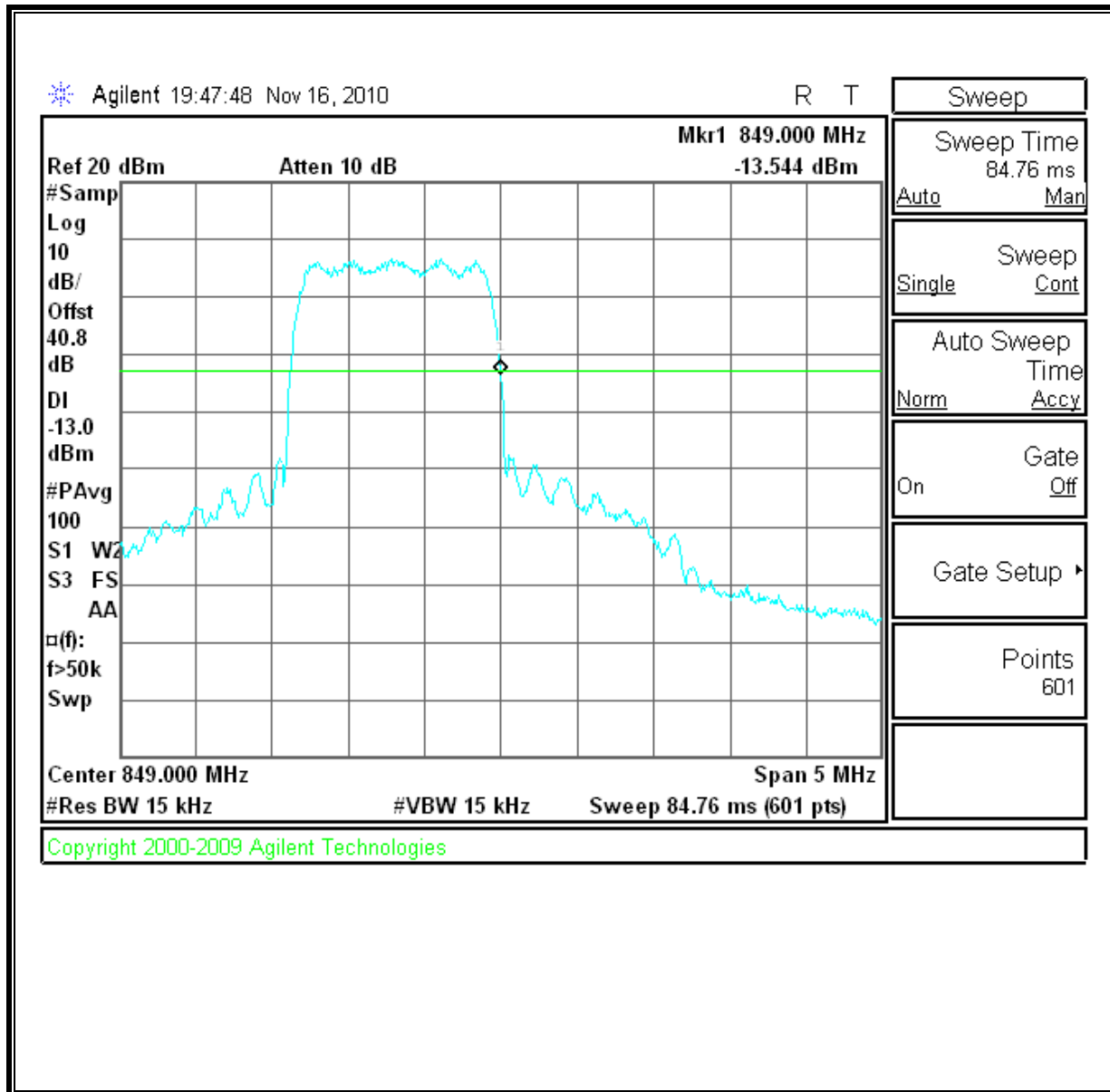

CDMA2000 1xEV-DO Revision A (Rev. A) mode (Cellular Band)

Low Channel Band Edge

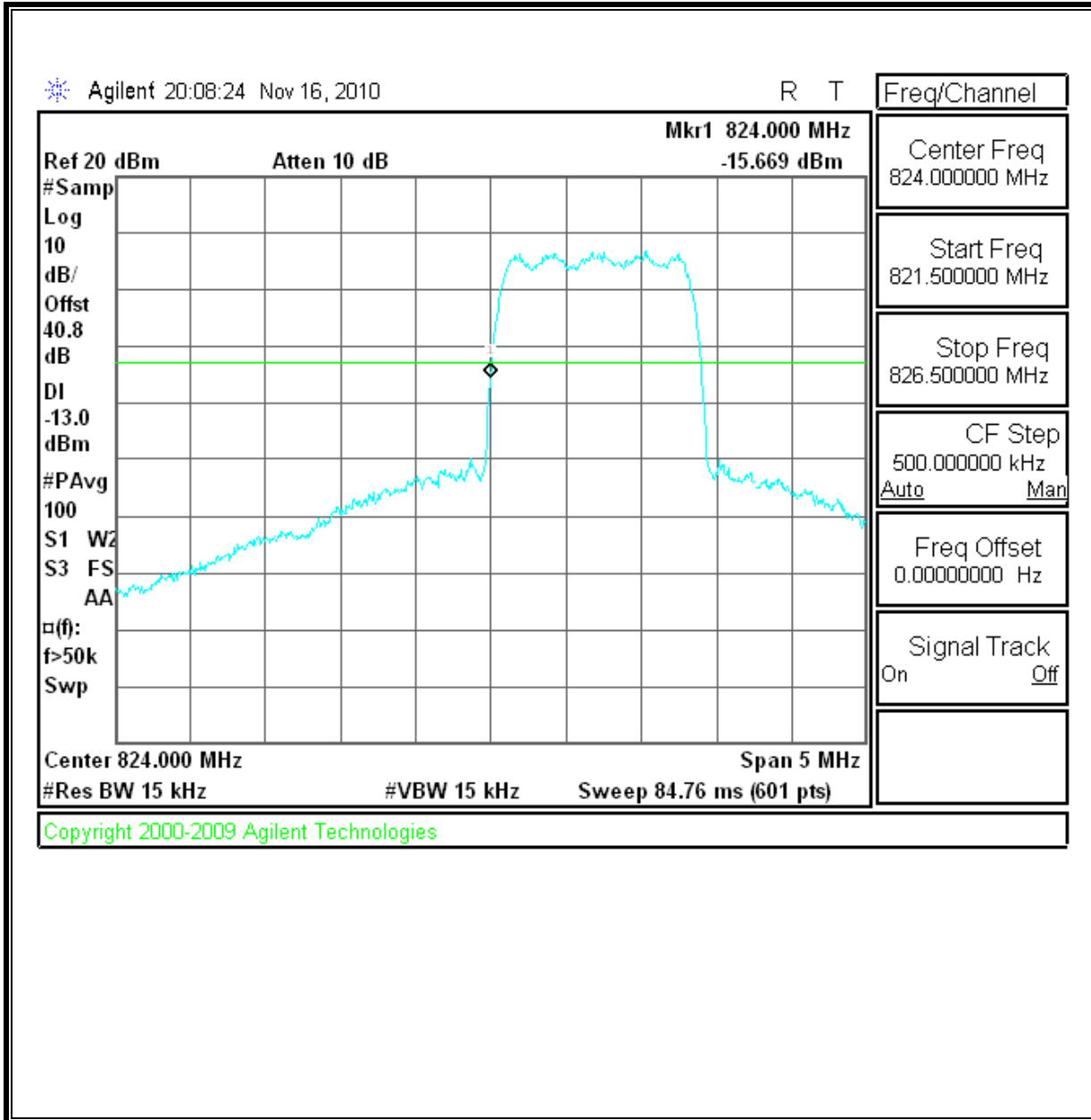

High Channel Band Edge

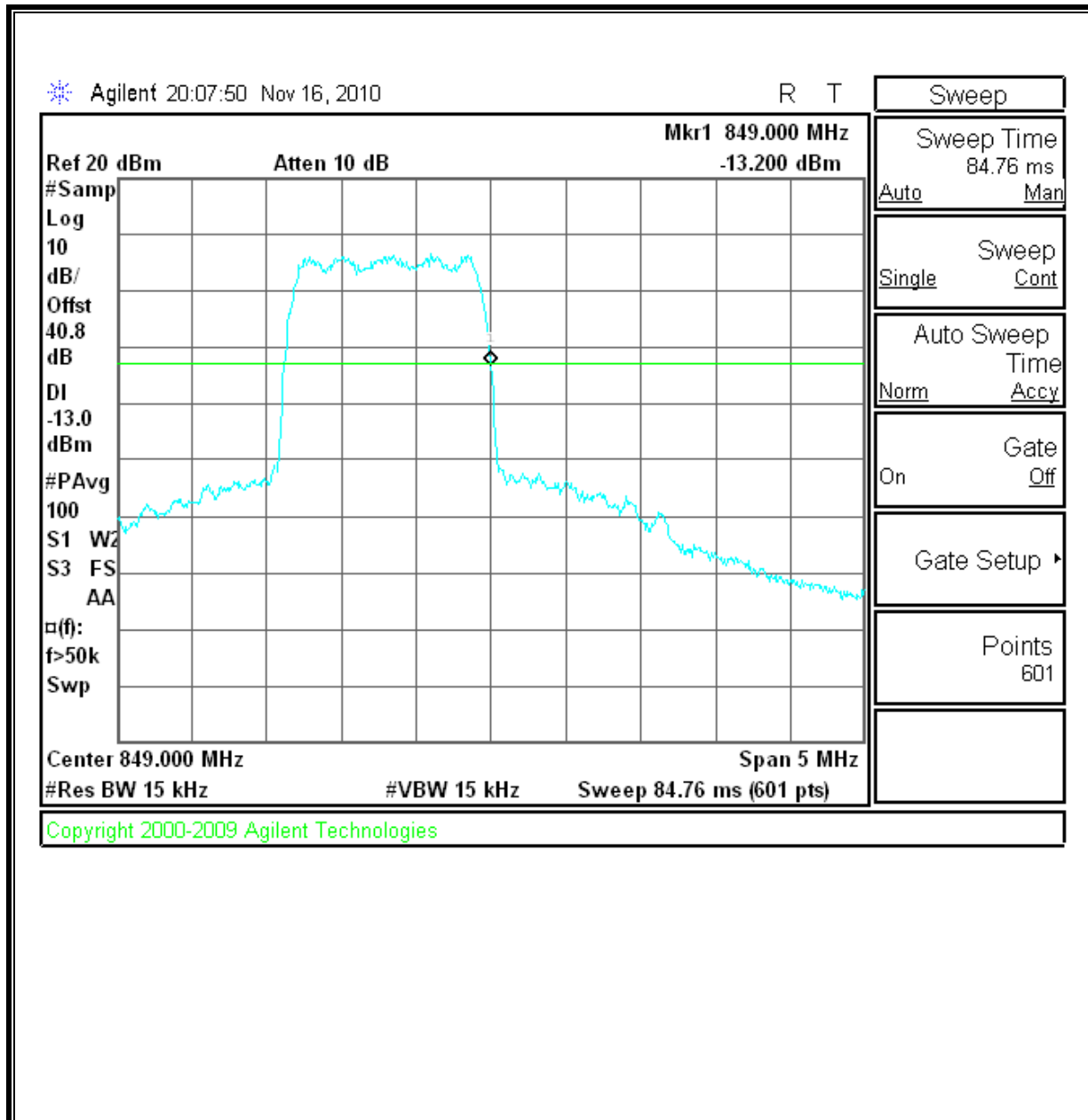

CDMA2000 1xRTT mode (PCS Band)

Low Channel Band Edge

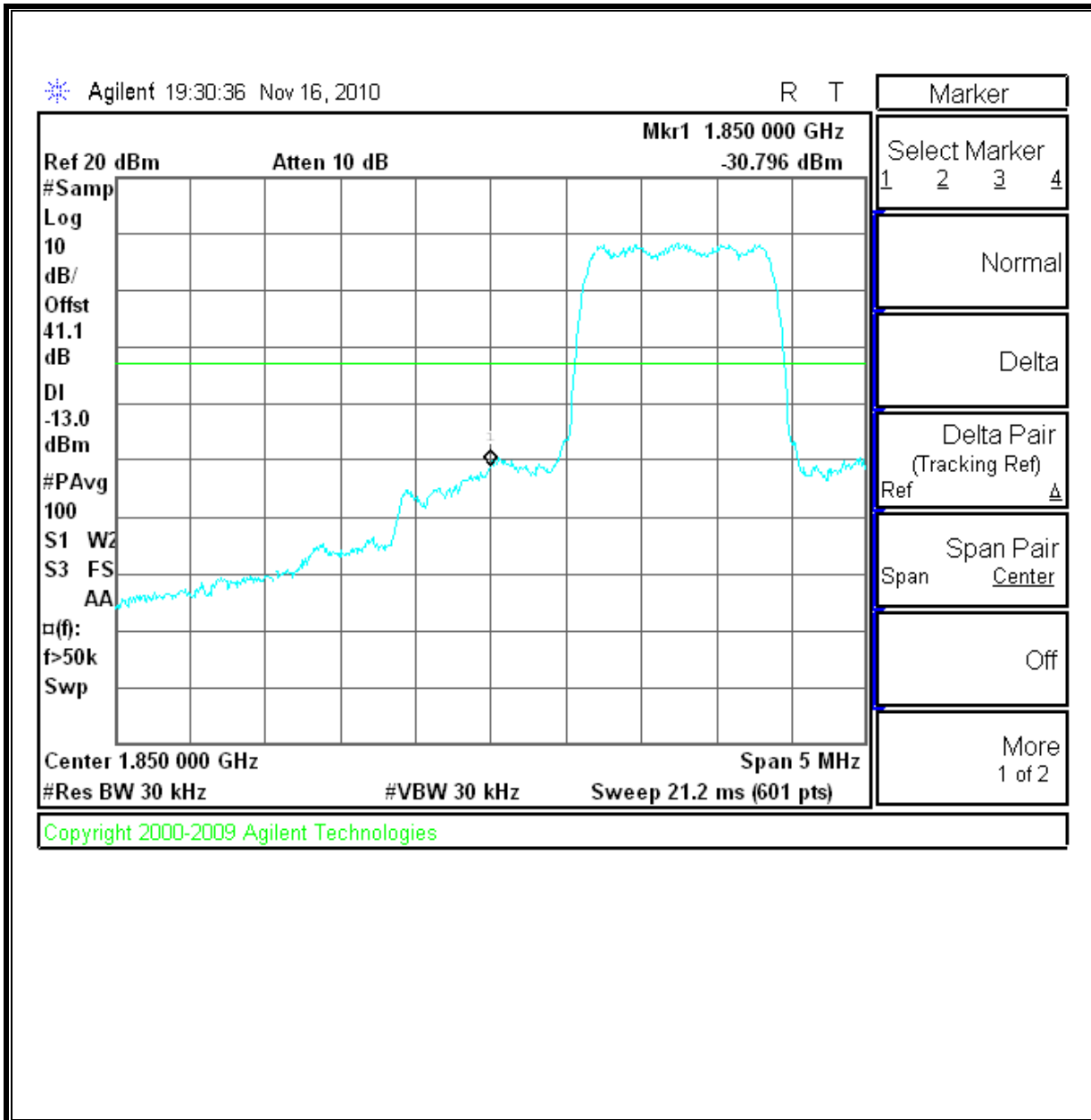

High Channel Band Edge

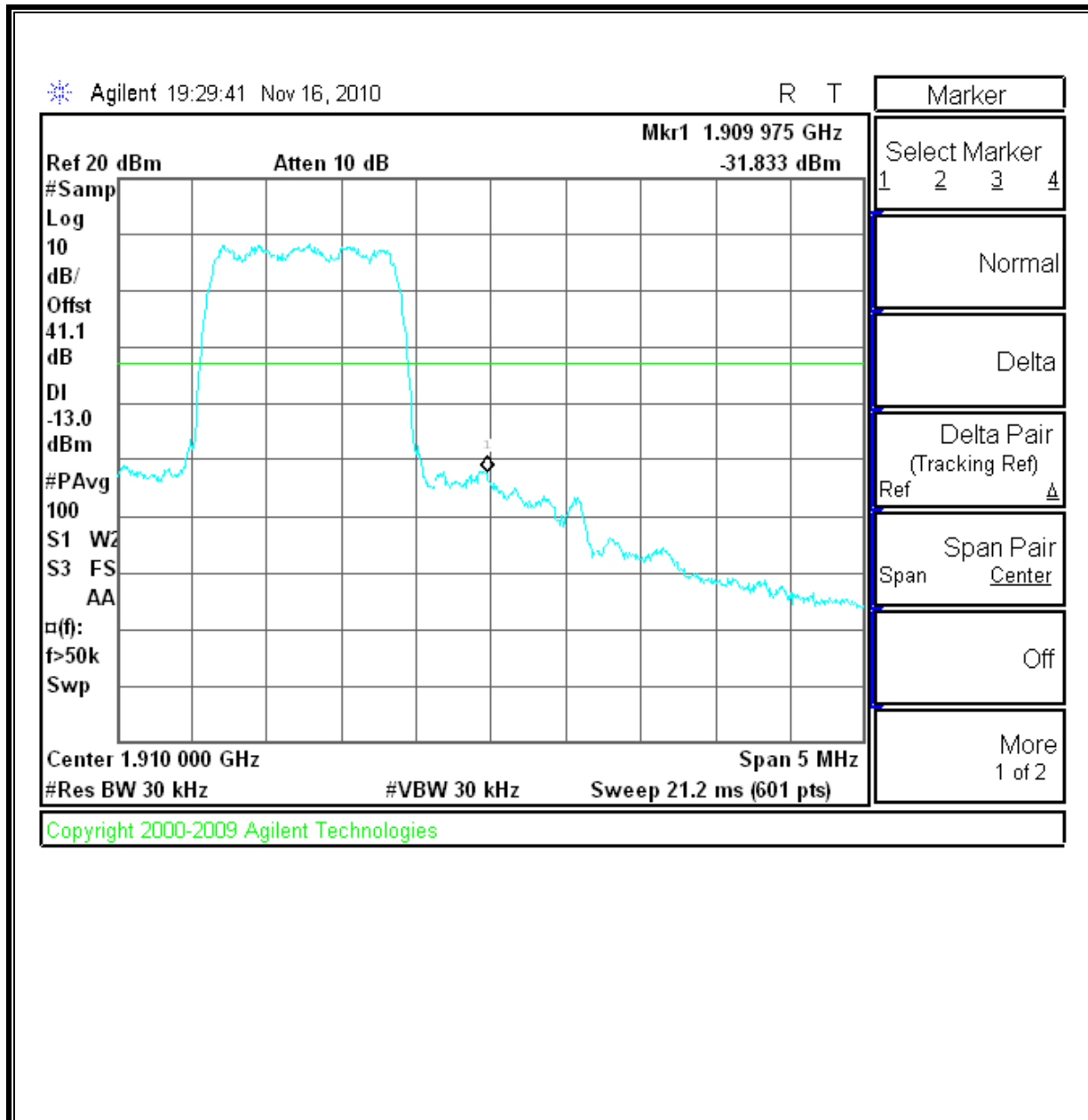

CDMA2000 1xEV-DO Revision A (Rev. A) mode (PCS Band)

Low Channel Band Edge

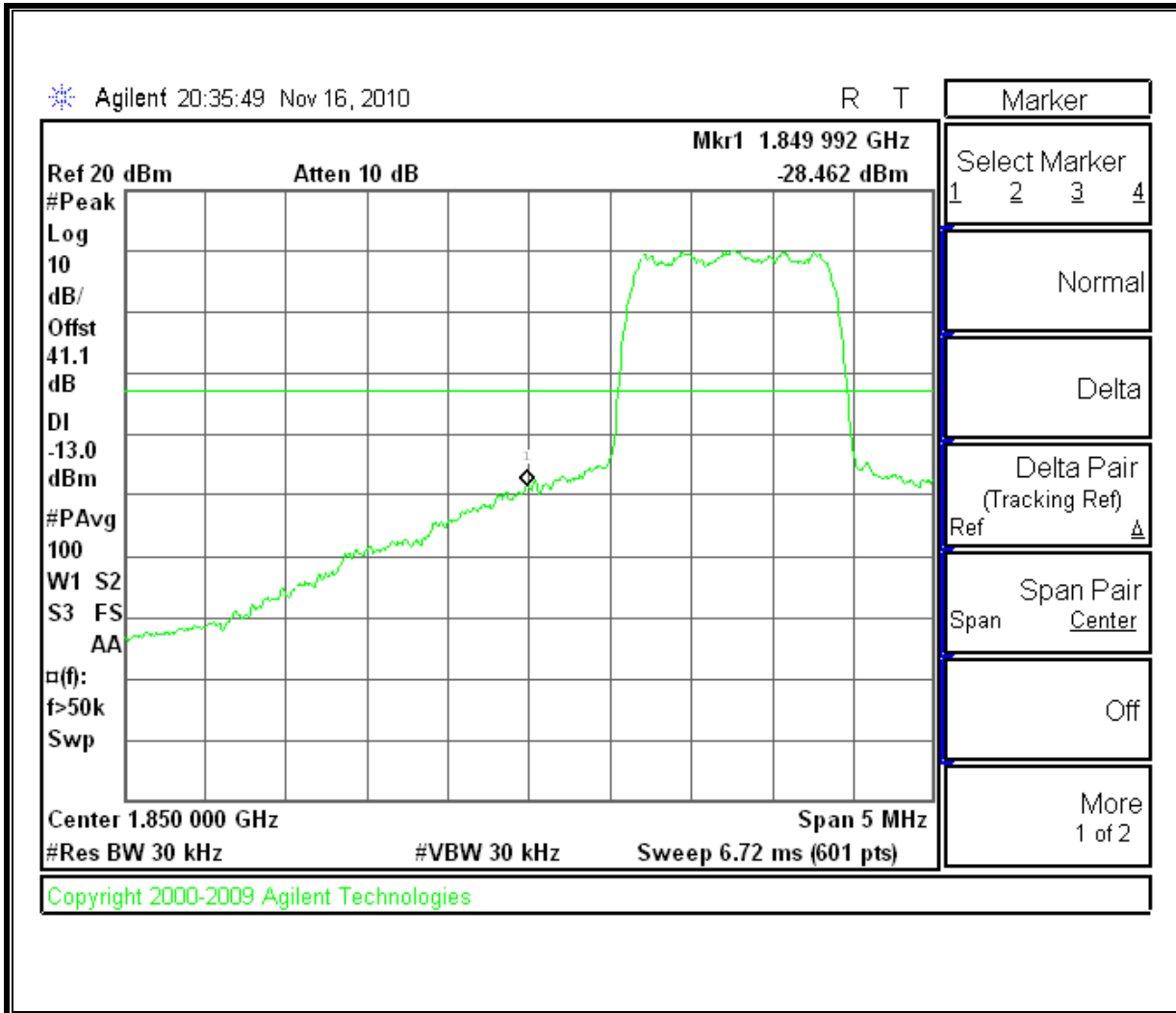

High Channel Band Edge

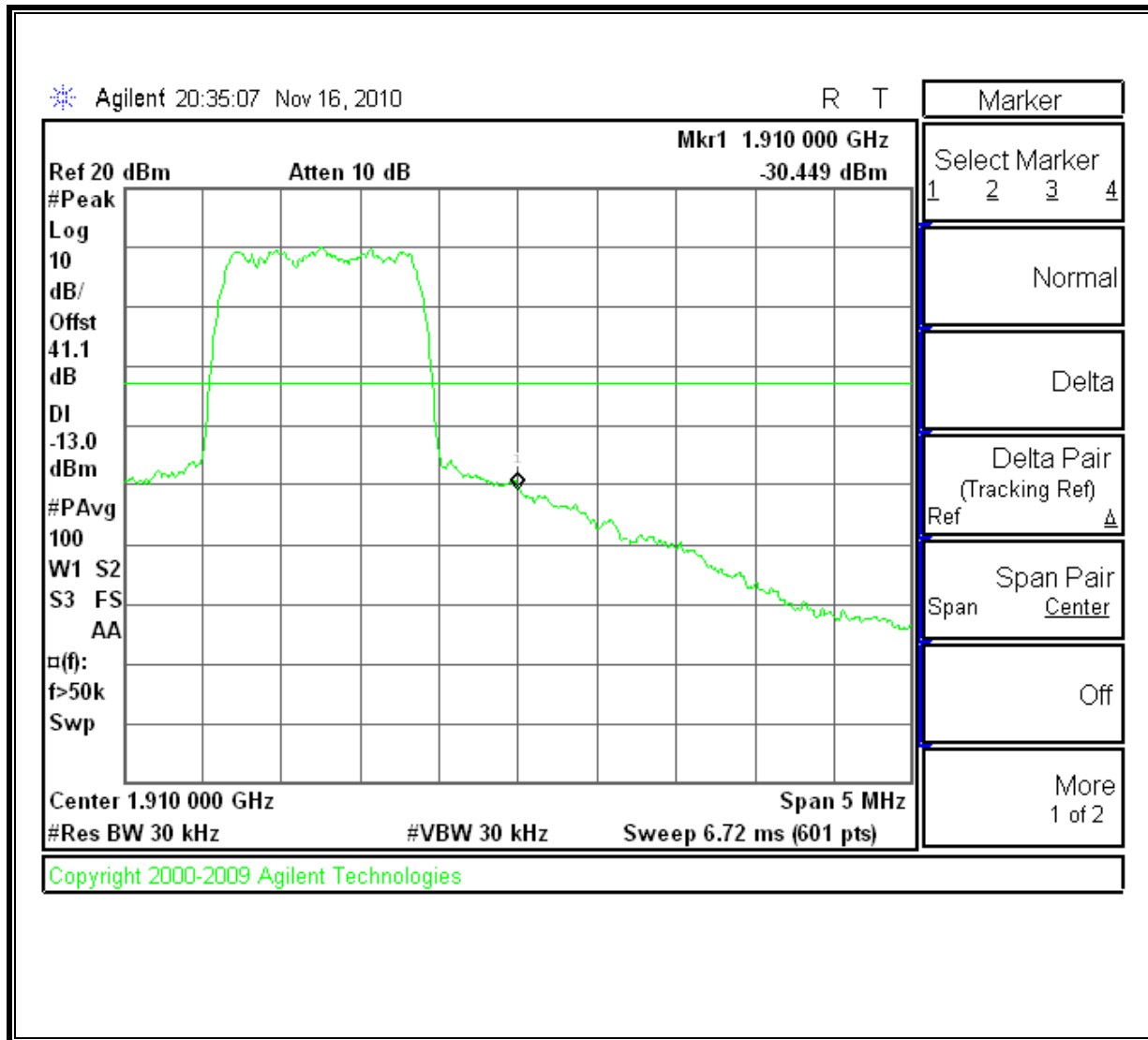

8.3. OUT OF BAND EMISSIONS

RULE PART(S)

FCC: §2.1051, §22.901, §22.917, §24.238

IC: RSS-132, 4.5; RSS-133, 6.5

LIMITS

The power of any emission outside of the authorized operating frequency ranges must be attenuated below the transmitting power (P) by a factor of at least $43 + 10 \log (P)$ dB.

TEST PROCEDURE

The RF output of the transmitter was connected to a spectrum analyzer through a calibrated coaxial cable. Sufficient scans were taken to show the out-of-band Emissions, if any, up to 10th harmonic. Multiple sweeps were recorded in maximum hold mode using a peak detector to ensure that the worst-case emissions were caught.

For each out of band emissions measurement:

- Set display line at -13 dBm
- Set RBW & VBW to 100 kHz for the measurement below 1 GHz, and 1 MHz for the measurement above 1 GHz.

MODES TESTED

- 1xRTT – RC2, SO9
- CDMA2000 1xEV-DO Revision A (Rev. A)

RESULTS

1xRTT Mode (Cellular Band)

LOW CHANNEL

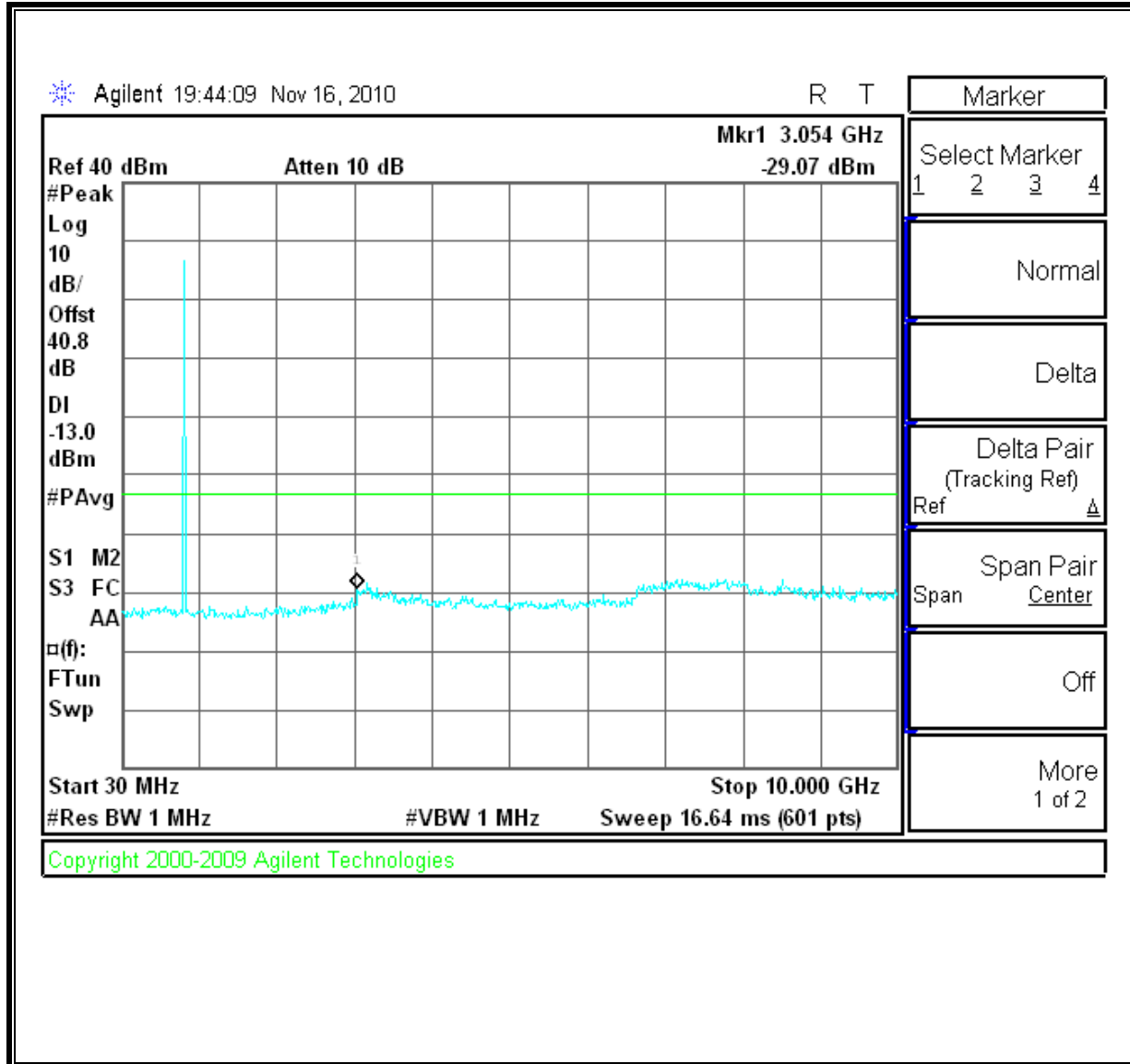

MID CHANNEL

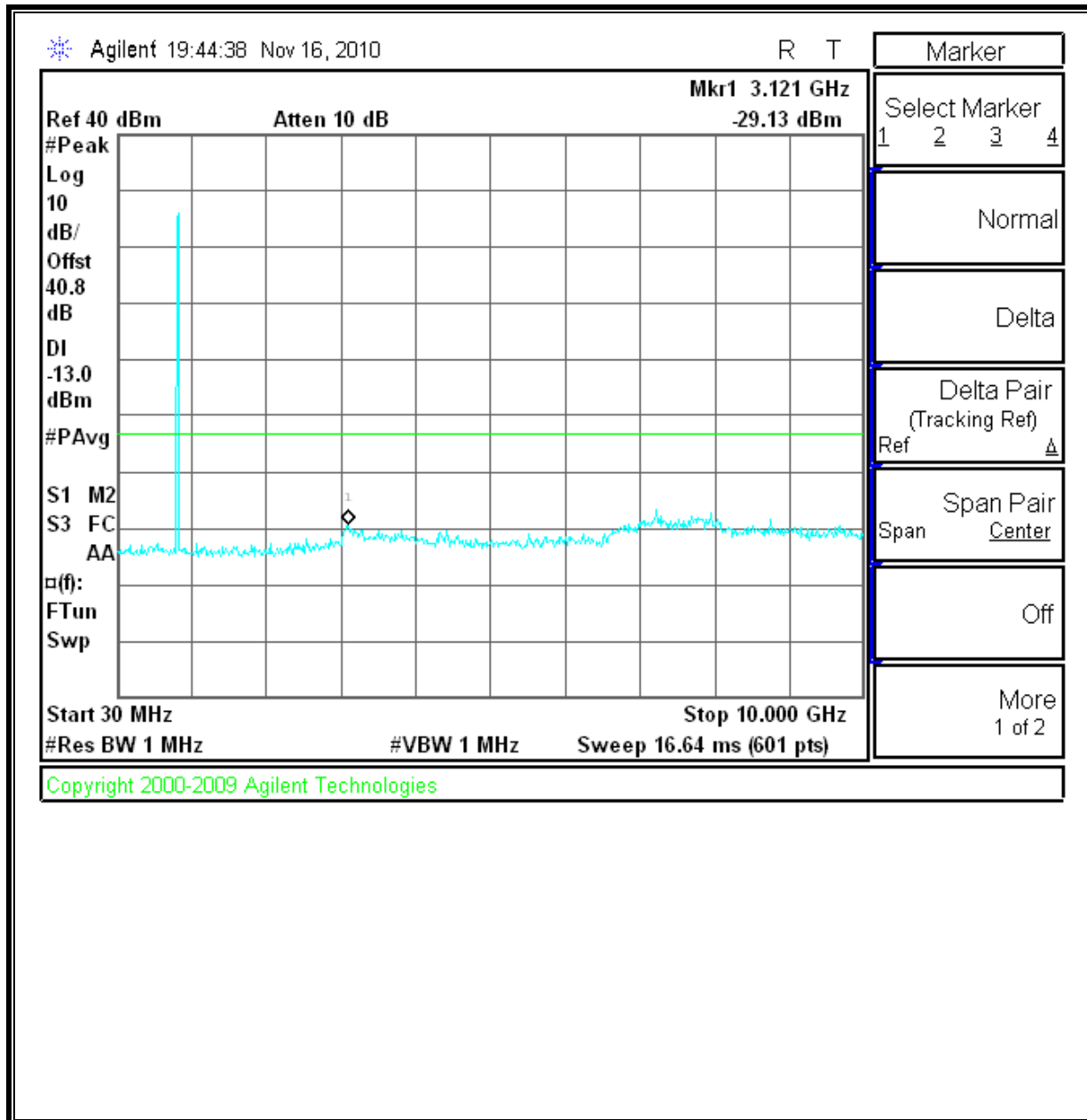

High Channel

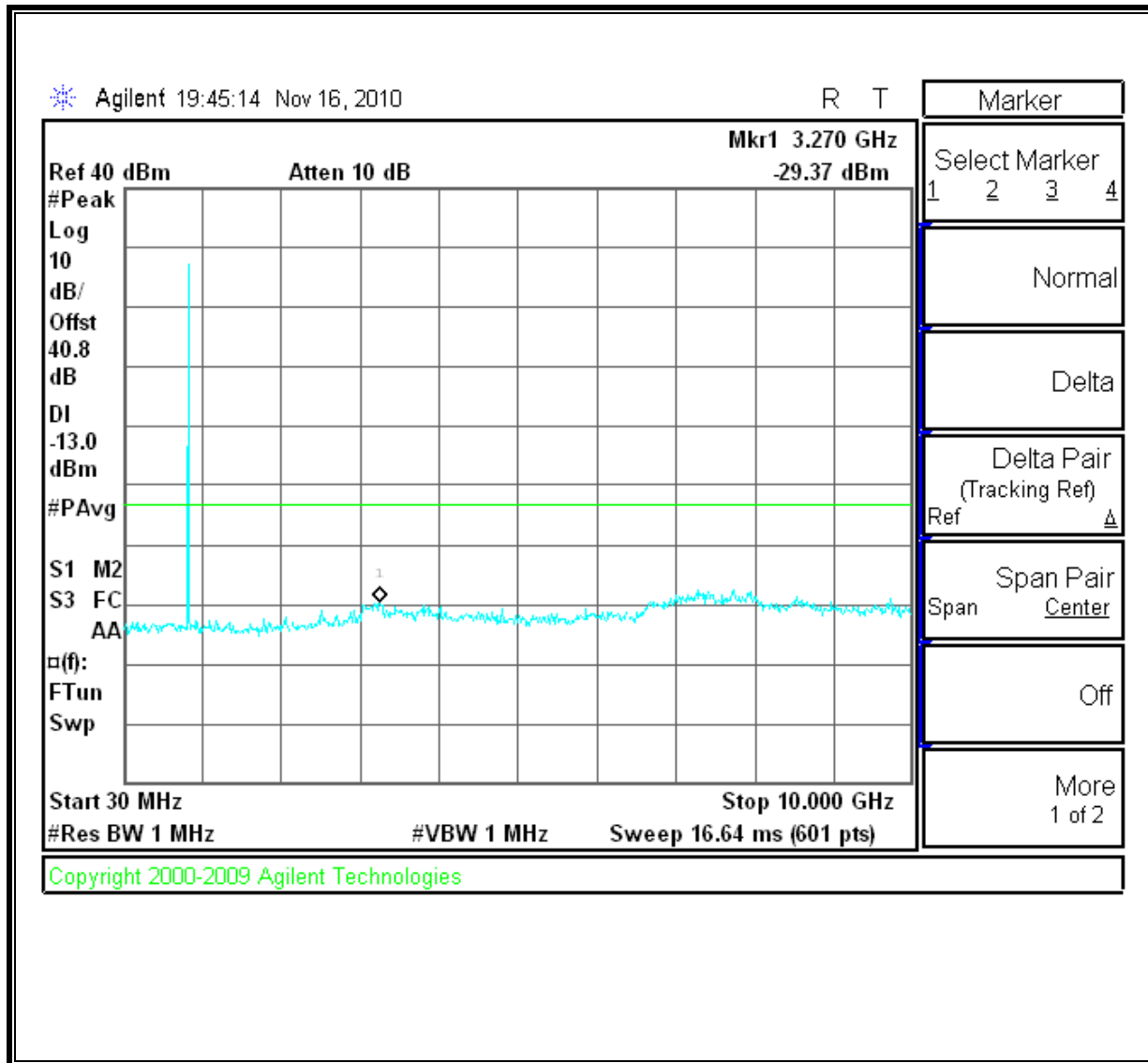

CDMA2000 1xEV-DO Revision A (Rev. A) Mode (Cellular Band)

LOW CHANNEL

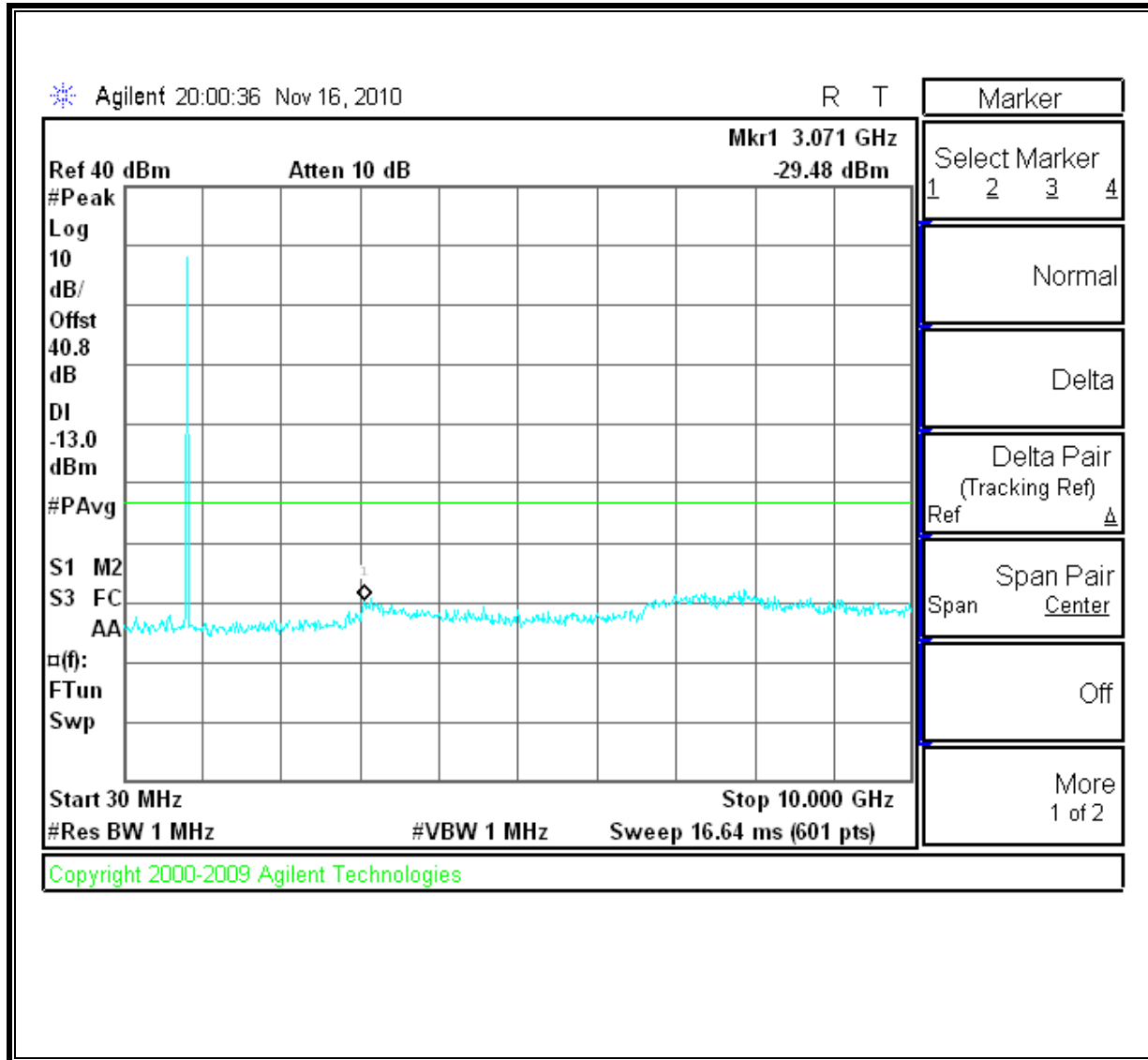

MID CHANNEL

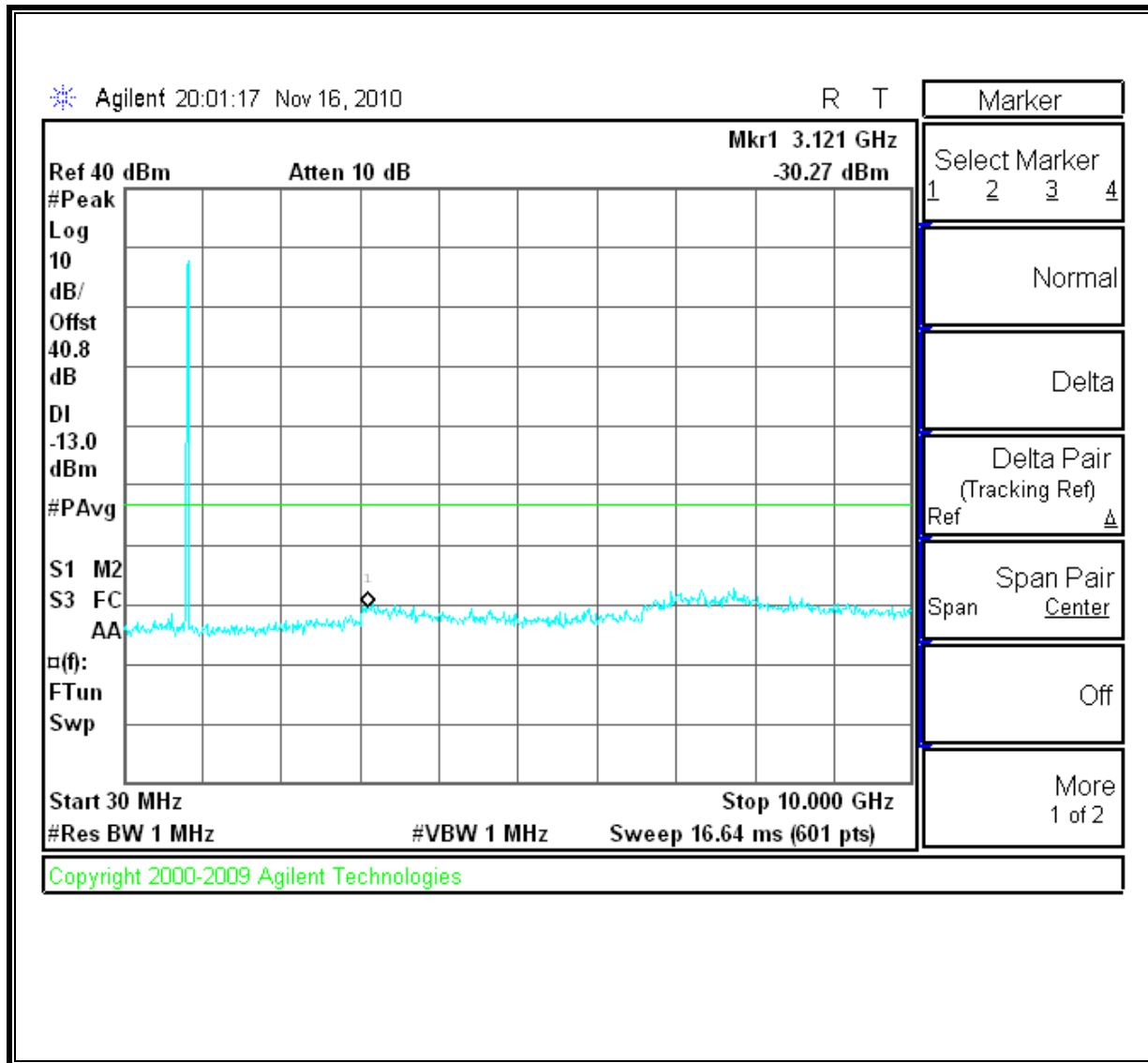

HIGH CHANNEL

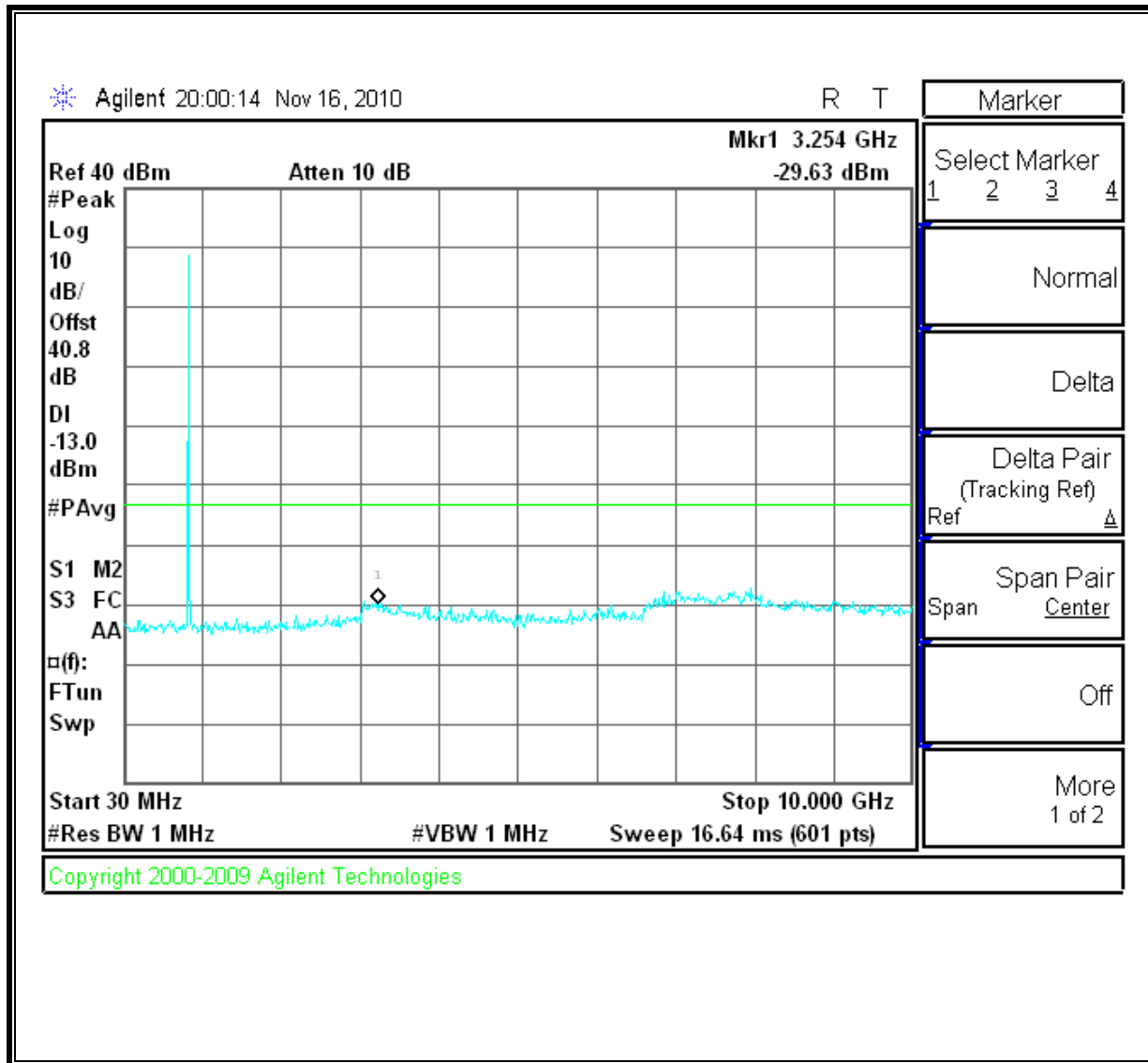

1xRTT Mode (PCS Band)

LOW CHANNEL

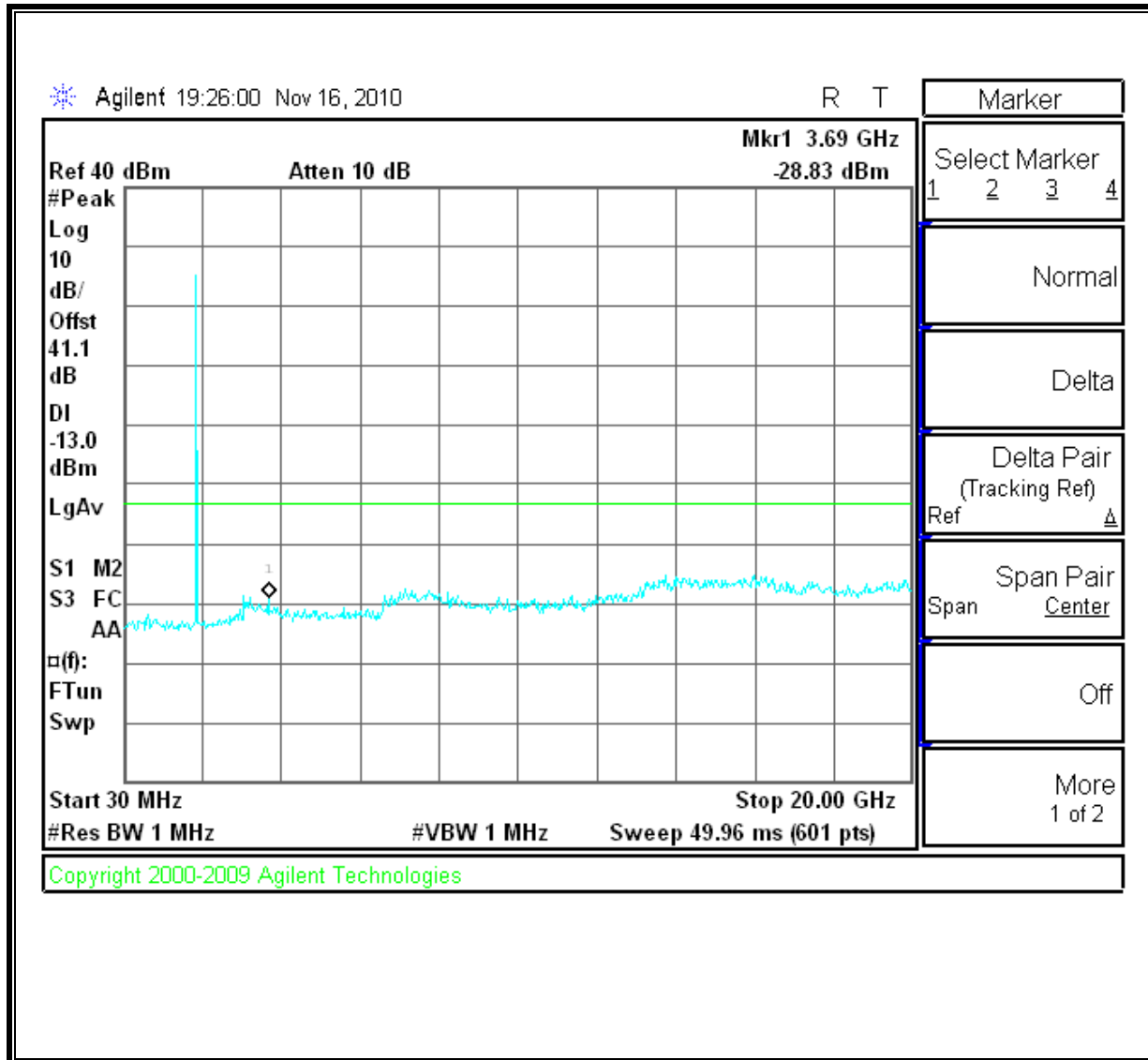

MID CHANNEL

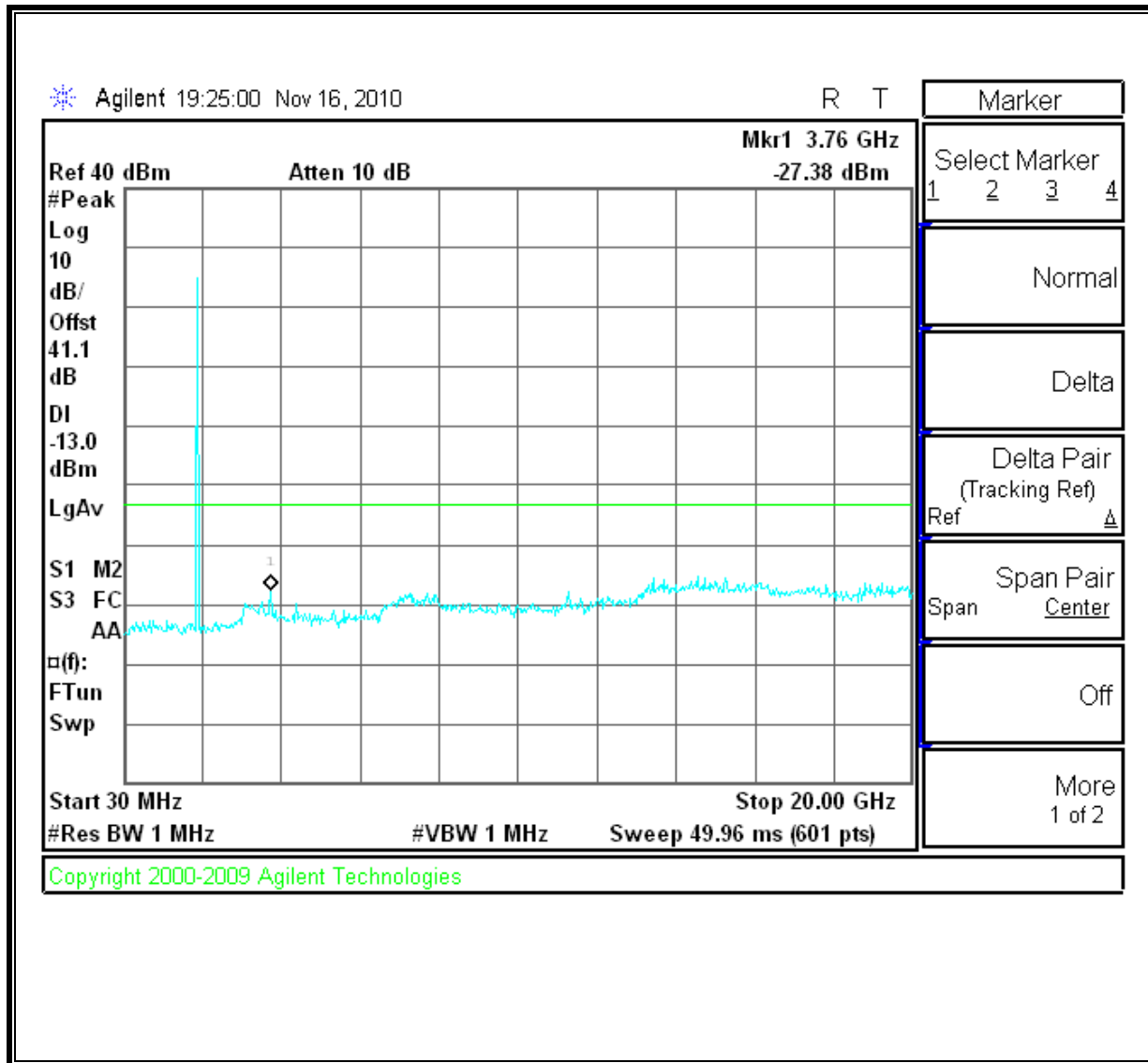

HIGH CHANNEL

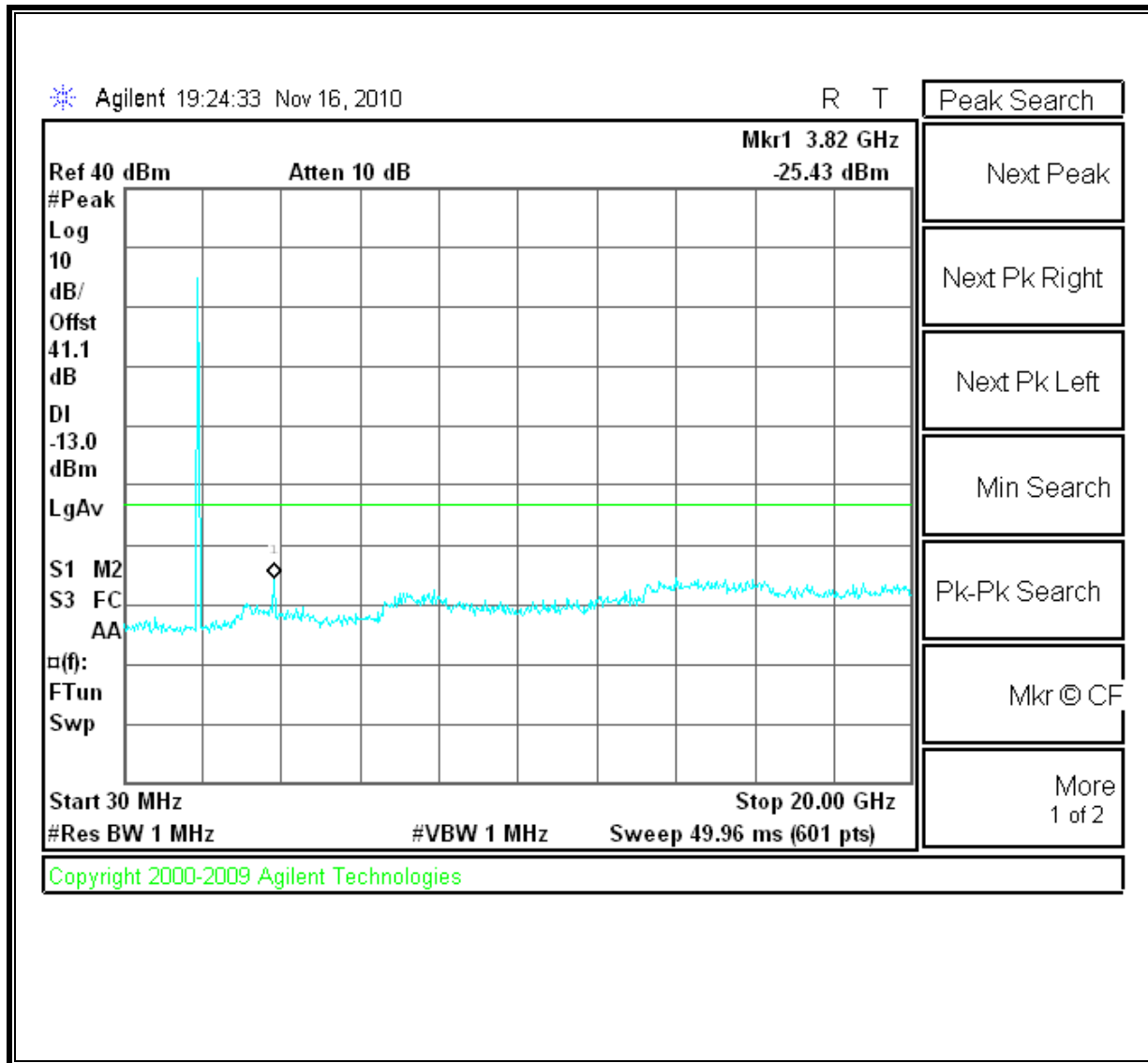

CDMA2000 1xEV-DO Revision A (Rev. A) Mode (PCS Band)

LOW CHANNEL

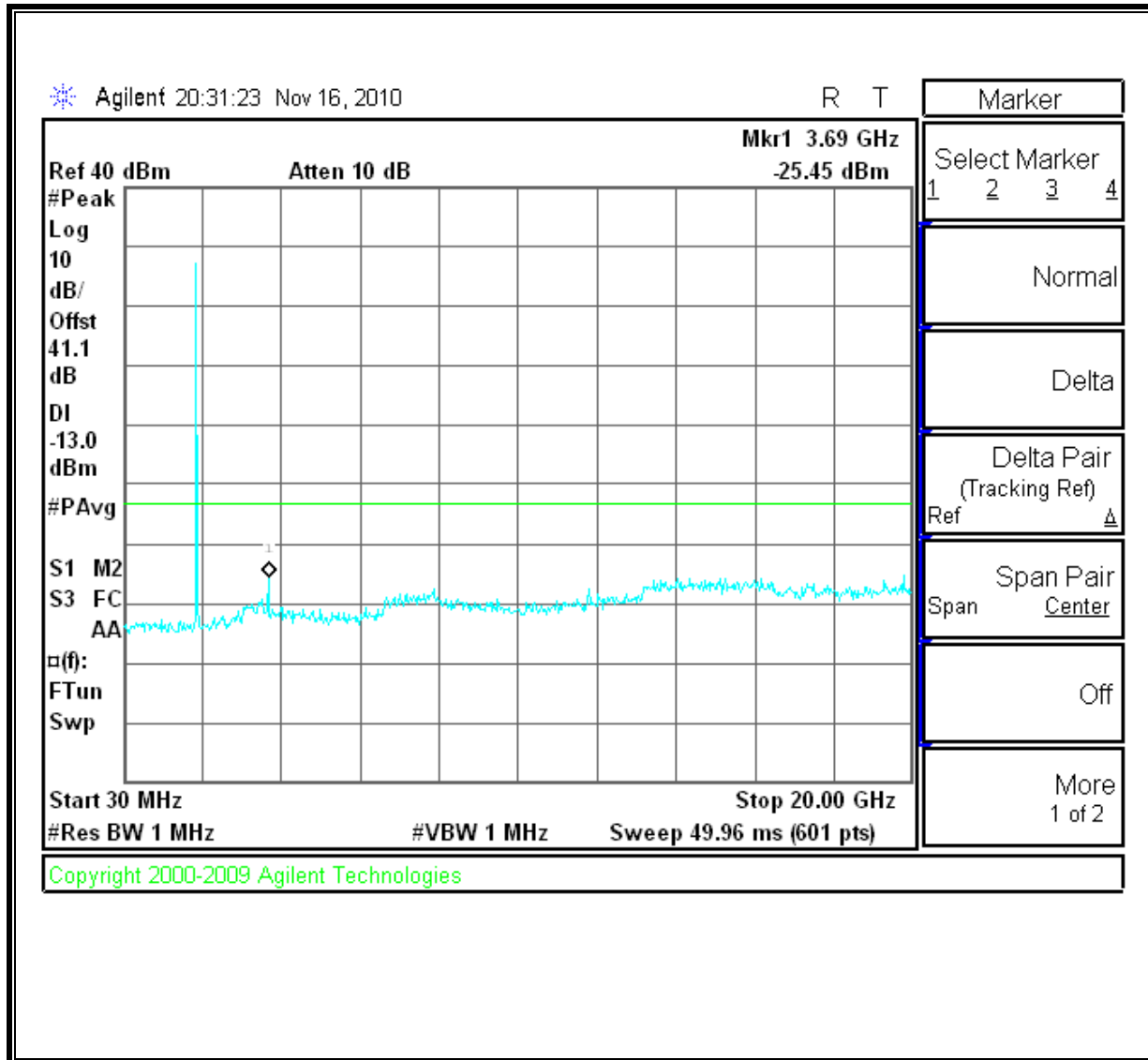

MID CHANNEL

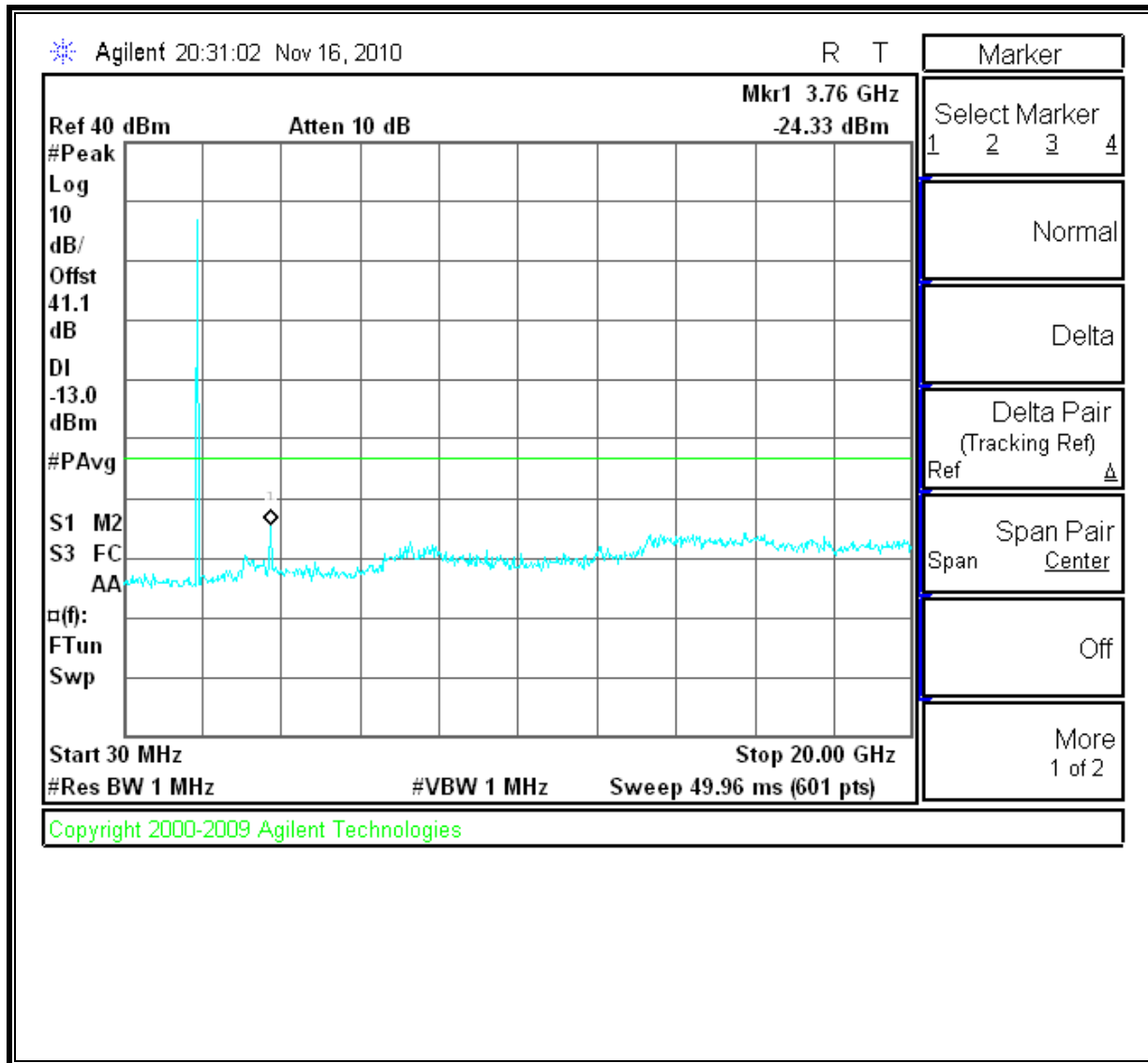

HIGH CHANNEL

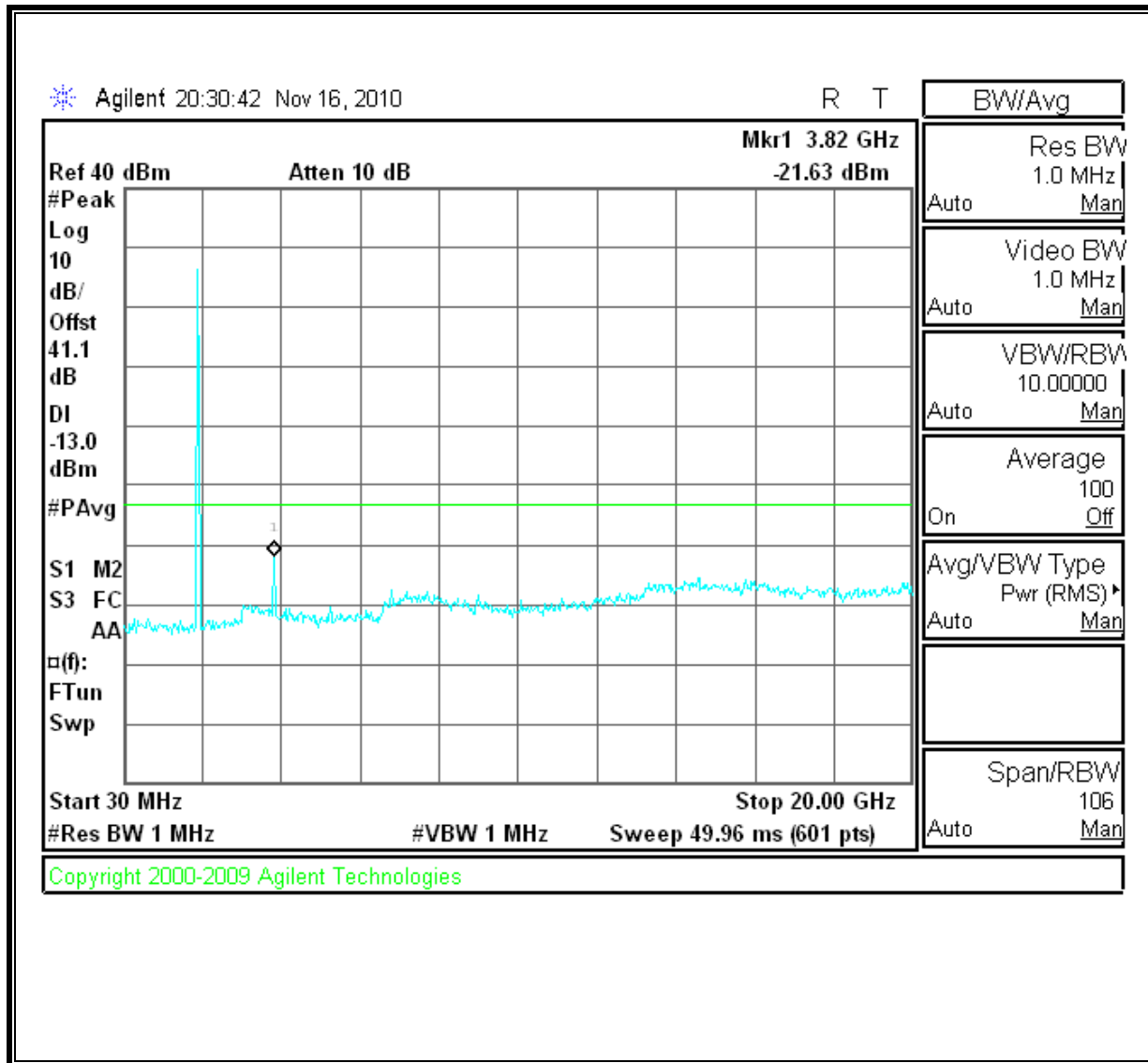

8.4. FREQUENCY STABILITY

RULE PART(S)

FCC: §2.1055, §22.355, §24.235
IC: RSS-132, 4.3; RSS-133, 6.3

LIMITS

- §22.355 & RSS-132 4.3 - The carrier frequency shall not depart from the reference frequency in excess of ± 2.5 ppm for mobile stations.
- RSS-133 6.3 - The carrier frequency shall not depart from the reference frequency in excess of ± 2.5 ppm for mobile stations.
- §24.235 - The frequency stability shall be sufficient to ensure that the fundamental emission stays within the authorized frequency block.

TEST PROCEDURE

Use Agilent 8960 with Frequency Error measurement capability.

- Temp. = -20° to $+50^{\circ}\text{C}$
- Voltage = 3.7 Vdc (85% - 115%)

Frequency Stability vs Temperature:

The EUT is placed inside a temperature chamber. The temperature is set to 20°C and allowed to stabilize. After sufficient soak time, the transmitting frequency error is measured. The temperature is increased by 10 degrees, allowed to stabilize and soak, and then the measurement is repeated. This is repeated until $+50^{\circ}\text{C}$ is reached.

Frequency Stability vs Voltage:

The peak frequency error is recorded (worst-case).

MODES TESTED

- CDMA2000 1xEV-DO Revision A (Rev. A)

RESULTS

See the following pages.

CELL CDMA2000 1xEV-DO Revision A (Rev. A) – MID CHANNEL

Reference Frequency: Cellular Mid Channel 836.520003Hz @ 20°C				
Limit: to stay +/- 2.5 ppm = 2091.300 Hz				
DC Power Supply (Vdc)	Environment Temperature (°C)	Frequency Deviation Measured with Time Elapse		
		(MHz)	Delta (ppm)	Limit (ppm)
3.70	50	836.520008	-0.006	2.5
3.70	40	836.520007	-0.005	2.5
3.70	30	836.520005	-0.002	2.5
3.70	20	836.520003	0	2.5
3.70	10	836.520002	0.001	2.5
3.70	0	836.520004	-0.001	2.5
3.70	-10	836.519995	0.010	2.5
3.70	-20	836.519991	0.014	2.5
3.70	-30	836.519990	0.016	2.5

Reference Frequency: Cellular Mid Channel 836.520003MHz @ 20°C				
Limit: to stay +/- 2.5 ppm = 2091.300 Hz				
DC Power Supply (Vdc)	Environment Temperature (°C)	Frequency Deviation Measured with Time Elapse		
		(MHz)	Delta (ppm)	Limit (ppm)
100%	20	836.520003	0	2.5
85%	20	836.520006	-0.004	2.5
115%	20	836.520002	0.001	2.5
3.2VDC (end voltage)	20	836.519997	0.007	2.5

PCS, CDMA2000 1xEV-DO Revision A (Rev. A) – MID CHANNEL

Reference Frequency: PCS Mid Channel 1879.999995MHz @ 20°C				
Limit: within the authorized block or +/- 2.5 ppm = 4700.000 Hz				
Power Supply (Vdc)	Environment Temperature (°C)	Frequency Deviation Measured with Time Elapse		
		(MHz)	Delta (ppm)	Limit (ppm)
3.70	50	1879.999992	0.002	2.5
3.70	40	1879.999990	0.003	2.5
3.70	30	1879.999997	-0.001	2.5
3.70	20	1879.999995	0	2.5
3.70	10	1879.999996	-0.001	2.5
3.70	0	1879.999990	0.003	2.5
3.70	-10	1880.000009	-0.007	2.5
3.70	-20	1879.999993	0.001	2.5
3.70	-30	1879.999990	0.003	2.5

Reference Frequency: PCS Mid Channel 1879.999995MHz @ 20°C				
Limit: within the authorized block or +/- 2.5 ppm = 4700.000 Hz				
Power Supply (Vdc)	Environment Temperature (°C)	Frequency Deviation Measured with Time Elapse		
		(MHz)	Delta (ppm)	Limit (ppm)
100%	20	1879.999995	0	2.5
0.85	20	1879.999993	0.001	2.5
1.15	20	1879.999996	-0.001	2.5
3.2V (End Point)	20	1879.999990	0.003	2.5

9. RADIATED TEST RESULTS

9.1. RADIATED POWER (ERP & EIRP)

RULE PART(S)

FCC: §2.1046, §22.913, §24.232

IC: RSS-132; 4.4, RSS-133, 6.4

LIMITS

22.913(a) - The ERP of mobile transmitters and auxiliary test transmitters must not exceed 7 Watts.

24.232(c) & RSS-133 § 6.4 - Mobile/portable stations are limited to 2 watts e.i.r.p. peak power and the equipment must employ means to limit the power to the minimum necessary for successful communications.

RSS-132 4.4, SRSP503 5.1.3 - The maximum ERP shall be 11.5 Watts for mobile stations.

TEST PROCEDURE

ANSI / TIA / EIA 603C

RSS-132; RSS-133

Path Loss method using Pre-calibrated Substitution values:

1. Configure the EUT per instructions in the standard with respect to whether antenna or resistive load should be connected to antenna port.
2. For measurements in the 30 - 1000 MHz region testing is to be performed on a qualified open area test site (OATS) with a ground plane. For measurements above 1 GHz, it is not mandatory that a test site with metallic ground plane be used.
3. Perform radiated emissions testing per CCS Core Test Procedure 4.5 or 4.6 as appropriate to the frequency of interest, with the measurement antenna in a selected polarization.

4. Record the raw spectrum analyzer reading. Calculate the radiated output power using:

- $ERP \text{ or } EIRP = \text{Spectrum Analyzer Reading (dBm)} + \text{Path Loss (dB)}$

Or if a preamp and/or filter is used during the measurement procedure:

- $ERP \text{ or } EIRP = \text{Spectrum Analyzer Reading (dBm)} + \text{Path Loss (dB)} - \text{Preamp Gain (dB)} + \text{Filter Loss (dB)}$

Where

- Path Loss was measured in the same chamber / OATS, with the same measurement antenna, the same measurement path coax cables, and the applicable polarization and EUT height, with respect to a dipole under 1 GHz or with respect to an isotropic source above 1 GHz
5. NOTE: The Pre-calibrated path loss must have been measured without a preamplifier or filter, otherwise the above equations must be adjusted accordingly. If this recommended practice was followed during the Pre-calibrated procedure, only the measurement antenna, measurement path coax cables, and facility form the matched set. Other components (e.g. preamplifier) may be included during the measurement procedure as required to meet sensitivity requirements and avoid overload by including their gains and losses in accordance with the above equation.

6. Repeat for other frequencies of interest and the other polarization as required.

MODES TESTED

- 1xRTT – RC2, SO9
- CDMA2000 1xEV-DO Revision A (Rev. A)

RESULTS for Cellular Band (ERP)

Mode	Channel	f (MHz)	ERP	
			dBm	mW
1xRTT (RC1, SO55)	1013	824.70	24.40	275.42
	384	836.52	25.90	389.05
	777	848.31	26.20	416.87
EVDO-REV A	1013	824.70	27.00	501.19
	384	836.52	27.40	549.54
	777	848.31	27.90	616.60

RESULTS for PCS Band (EIRP)

Mode	Channel	f (MHz)	EIRP	
			dBm	mW
1xRTT (RC1, SO55)	25	1851.25	25.20	331.13
	600	1880.00	26.00	398.11
	1175	1908.75	26.90	489.78
EVDO-REV A	25	1851.25	28.00	630.96
	600	1880.00	28.10	645.65
	1175	1908.75	27.70	588.84

ERP for 1xRTT Mode (Cellular Band)

High Frequency Substitution Measurement Compliance Certification Services Chamber B							
Company:		Apple					
Project #:		10U13473					
Date:		11/16/2010					
Test Engineer:		Chin Pang					
Configuration:		EUT with earphone and AC Adapter					
Mode:		TX, CELL, CDMA 2000 1xRTT					
Test Equipment:							
Receiving: Sunol T130, and 3m Chamber N-type Cable (Setup this one for testing EUT)							
Substitution: Dipole S/N: 00022117, 6ft SMA Cable (SN # 208947003) Warehouse.							
f MHz	SA reading (dBm)	Ant. Pol. (H/V)	Path Loss (dBm)	ERP (dBm)	Limit (dBm)	Margin (dB)	Notes
Low Ch							
824.70	-9.0	V	32.6	23.6	38.5	-14.9	
824.70	-6.0	H	30.4	24.4	38.5	-14.1	
Mid Ch							
836.52	-6.8	V	32.7	25.8	38.5	-12.6	
836.52	-4.8	H	30.7	25.9	38.5	-12.5	
High Ch							
848.31	-6.7	V	32.0	25.3	38.5	-13.2	
848.31	-4.6	H	30.8	26.2	38.5	-12.3	
Rev. 1.24.7							

ERP for CDMA2000 1xEV-DO Revision A (Rev. A) Mode (Cellular Band)

High Frequency Substitution Measurement Compliance Certification Services Chamber B							
Company:		Apple					
Project #:		10U13473					
Date:		11/16/2010					
Test Engineer:		Chin Pang					
Configuration:		EUTwith earphone and AC Adapter					
Mode:		TX, CELL, EVDO Rev A					
Test Equipment:							
Receiving: Sunol T130, and 3m Chamber N-type Cable (Setup this one for testing EUT)							
Substitution: Dipole S/N: 00022117, 6ft SMA Cable (SN # 208947003) Warehouse.							
f MHz	SA reading (dBm)	Ant. Pol. (H/V)	Path Loss (dBm)	ERP (dBm)	Limit (dBm)	Margin (dB)	Notes
Low Ch							
824.70	-5.6	V	32.6	27.0	38.5	-11.4	
824.70	-12.8	H	30.4	17.6	38.5	-20.9	
Mid Ch							
836.52	-5.2	V	32.7	27.4	38.5	-11.0	
836.52	-12.9	H	30.7	17.8	38.5	-20.6	
High Ch							
848.31	-4.1	V	32.0	27.9	38.5	-10.6	
848.31	-12.6	H	30.8	18.2	38.5	-20.3	
Rev. 1.24.7							

EIRP for 1xRTT Mode (PCS Band)

High Frequency Fundamental Measurement Compliance Certification Services Chamber B							
Company:Apple							
Project #:10U13473							
Date: 11/16/2010							
Test Engineer: Chin Pang							
Configuration:EUT with earphone and AC Adapter							
Mode:TX, PCS, CDMA2000 1xRTT							
Test Equipment:							
Receiving: Horn T59, and Camber B SMA Cables							
Substitution: Horn T72 Substitution, 6ft SMA Cable (208947003) Warehouse							
f GHz	SA reading (dBm)	Ant. Pol. (H/V)	Path Loss (dBm)	EIRP (dBm)	Limit (dBm)	Delta (dB)	Notes
Low Ch							
1.851	-15.0	V	40.2	25.2	33.0	-7.8	
1.851	-17.0	H	39.5	22.5	33.0	-10.5	
Mid Ch							
1.880	-14.3	V	40.3	26.0	33.0	-7.1	
1.880	-18.0	H	40.1	22.1	33.0	-10.9	
High Ch							
1.909	-13.3	V	40.2	26.9	33.0	-6.1	
1.909	-17.6	H	40.1	22.5	33.0	-10.5	
Rev. 1.24.7							

EIRP for CDMA2000 1xEV-DO Revision A (Rev. A) Mode (PCS Band)

High Frequency Fundamental Measurement Compliance Certification Services Chamber B							
Company:Apple							
Project #:10U13473							
Date: 11/16/2010							
Test Engineer: Chin Pang							
Configuration:EUT with earphone and AC adapter							
Mode:TX, PCS, EVDO Rev A							
Test Equipment:							
Receiving: Horn T59, and Camber B SMA Cables							
Substitution: Horn T72 Substitution, 6ft SMA Cable (208947003) Warehouse							
f GHz	SA reading (dBm)	Ant. Pol. (H/V)	Path Loss (dBm)	EIRP (dBm)	Limit (dBm)	Delta (dB)	Notes
Low Ch							
1.850	-12.2	V	40.2	28.0	33.0	-5.0	
1.850	-16.0	H	39.5	23.5	33.0	-9.5	
Mid Ch							
1.880	-12.2	V	40.3	28.1	33.0	-5.0	
1.880	-15.5	H	40.1	24.6	33.0	-8.4	
High Ch							
1.910	-12.5	V	40.2	27.7	33.0	-5.3	
1.910	-14.6	H	40.1	25.5	33.0	-7.5	
Rev. 1.24.7							

9.2. FIELD STRENGTH OF SPURIOUS RADIATION

RULE PART(S)

FCC: §2.1053, §22.917, §24.238
IC: RSS-132, 4.5; RSS-233, 6.5

LIMIT

The power of any emission outside of the authorized operating frequency ranges must be attenuated below the transmitting power (P) by a factor of at least $43 + 10 \log (P)$ dB.

TEST PROCEDURE

For Cellular equipment - Compliance with these rules is based on the use of measurement instrumentation employing a resolution bandwidth of 100 kHz or greater. In the 1 MHz bands immediately outside and adjacent to the frequency block a resolution bandwidth of at least one percent of the emission bandwidth of the fundamental emission of the transmitter may be employed. A narrower resolution bandwidth is permitted in all cases to improve measurement accuracy provided the measured power is integrated over the full required measurement bandwidth (i.e. 100 kHz or 1 percent of emission bandwidth, as specified). The emission bandwidth is defined as the width of the signal between two points, one below the carrier center frequency and one above the carrier center frequency, outside of which all emissions are attenuated at least 26 dB below the transmitter power.

For PCS equipment - Compliance with these rules is based on the use of measurement instrumentation employing a resolution bandwidth of 1 MHz or greater. However, in the 1 MHz bands immediately outside and adjacent to the frequency block a resolution bandwidth of at least one percent of the emission bandwidth of the fundamental emission of the transmitter may be employed. A narrower resolution bandwidth is permitted in all cases to improve measurement accuracy provided the measured power is integrated over the full required measurement bandwidth (i.e. 1 MHz or 1 percent of emission bandwidth, as specified). The emission bandwidth is defined as the width of the signal between two points, one below the carrier center frequency and one above the carrier center frequency, outside of which all emissions are attenuated at least 26 dB below the transmitter power.

MODES TESTED

- 1xRTT – RC2, SO9
- CDMA2000 1xEV-DO Revision A (Rev. A)

RESULTS

1xRTT Mode (Cellular Band)

Compliance Certification Services
 Above 1GHz High Frequency Substitution Measurement

Company: Apple
 Project #: 10U13473
 Date: 11/16/10
 Test Engineer: Chin Pang
 Configuration: EUT (SEMCO)with Earphone and AC adapter
 Mode: CDMA2000 1xRTT, Cell

Chamber

Pre-amplifier

Filter

Limit

5m Chamber B

T145 8449B

Filter 1

Part 22

f GHz	SA reading (dBm)	Ant. Pol. (H/V)	Distance (m)	Path Loss (dB)	Preamp (dB)	Filter (dB)	ERP (dBm)	Limit (dBm)	Delta (dB)	Notes
Low Ch										
1.649	-61.0	H	3.0	37.2	35.5	1.0	-60.5	-13.0	-47.5	
2.474	-65.0	H	3.0	39.8	35.4	1.0	-61.7	-13.0	-48.7	
1.649	-60.5	V	3.0	36.8	35.5	1.0	-60.4	-13.0	-47.4	
2.474	-64.2	V	3.0	41.7	35.4	1.0	-59.1	-13.0	-46.1	
Mid Ch										
1.673	-59.1	H	3.0	37.5	35.5	1.0	-58.3	-13.0	-45.3	
2.509	-63.5	H	3.0	39.9	35.4	1.0	-60.2	-13.0	-47.2	
1.673	-57.5	V	3.0	37.1	35.5	1.0	-57.1	-13.0	-44.1	
2.509	-63.8	V	3.0	41.8	35.4	1.0	-58.5	-13.0	-45.5	
High Ch										
1.697	-57.0	H	3.0	37.7	35.5	1.0	-56.0	-13.0	-43.0	
2.545	-64.0	H	3.0	40.1	35.4	1.0	-60.5	-13.0	-47.5	
1.697	-53.7	V	3.0	37.4	35.5	1.0	-52.9	-13.0	-39.9	
2.545	-65.0	V	3.0	42.0	35.4	1.0	-59.6	-13.0	-46.6	

Rev. 03.03.09
 Note: No other emissions were detected above the system noise floor

CDMA2000 1xEV-DO Revision A (Rev. A) Mode (Cellular Band)

Compliance Certification Services
Above 1GHz High Frequency Substitution Measurement

Company: Apple
Project #: 10U13473
Date: 11/16/10
Test Engineer: Chin Pang
Configuration: EUT (SEMCO)with Earphone and AC adapter
Mode: EVDO-Rev A, Cell

Chamber

5m Chamber B

Pre-amplifier

T145 8449B

Filter

Filter 1

Limit

Part 22

f GHz	SA reading (dBm)	Ant. Pol. (H/V)	Distance (m)	Path Loss (dB)	Preamp (dB)	Filter (dB)	ERP (dBm)	Limit (dBm)	Delta (dB)	Notes
Low Ch										
1.649	-61.4	H	3.0	37.2	35.5	1.0	-60.9	-13.0	-47.9	
2.474	-64.5	H	3.0	39.8	35.4	1.0	-61.2	-13.0	-48.2	
1.649	-60.0	V	3.0	36.8	35.5	1.0	-59.9	-13.0	-46.9	
2.474	-61.2	V	3.0	41.7	35.4	1.0	-56.1	-13.0	-43.1	
Mid Ch										
1.673	-56.9	H	3.0	37.5	35.5	1.0	-56.1	-13.0	-43.1	
2.509	-65.0	H	3.0	39.9	35.4	1.0	-61.7	-13.0	-48.7	
1.673	-56.0	V	3.0	37.1	35.5	1.0	-55.6	-13.0	-42.6	
2.509	-64.0	V	3.0	41.8	35.4	1.0	-58.7	-13.0	-45.7	
High Ch										
1.697	-56.0	H	3.0	37.7	35.5	1.0	-55.0	-13.0	-42.0	
2.545	-64.5	H	3.0	40.1	35.4	1.0	-61.0	-13.0	-48.0	
1.697	-53.4	V	3.0	37.4	35.5	1.0	-52.6	-13.0	-39.6	
2.545	-64.0	V	3.0	42.0	35.4	1.0	-58.6	-13.0	-45.6	

Rev. 03.03.09
Note: No other emissions were detected above the system noise floor

1xRTT Mode (PCS Band)

Compliance Certification Services Above 1GHz High Frequency Substitution Measurement										
Company: Apple Project #: 10U13473 Date: 11/16/10 Test Engineer: Chin Pang Configuration: EUT (SEMCO) with Earphone and AC Adapter Mode: TX, CDMA2000 1xRTT, PCS band										
Chamber		Pre-amplifier			Filter		Limit			
5m Chamber B		T145 8449B			Filter 1		Part 24			
f GHz	SA reading (dBm)	Ant. Pol. (H/V)	Distance (m)	Path Loss (dB)	Preamp (dB)	Filter (dB)	EIRP (dBm)	Limit (dBm)	Delta (dB)	Notes
Low Ch										
3.702	-64.8	H	3.0	45.3	35.4	1.0	-53.8	-13.0	-40.8	
5.554	-65.3	H	3.0	50.0	35.4	1.0	-49.7	-13.0	-36.7	
3.702	-64.8	V	3.0	45.1	35.4	1.0	-54.0	-13.0	-41.0	
5.554	-62.0	V	3.0	49.2	35.4	1.0	-47.2	-13.0	-34.2	
Mid Ch										
3.760	-64.4	H	3.0	45.5	35.3	1.0	-53.2	-13.0	-40.2	
5.640	-65.5	H	3.0	50.2	35.4	1.0	-49.8	-13.0	-36.8	
3.760	-65.2	V	3.0	45.3	35.3	1.0	-54.3	-13.0	-41.3	
5.640	-66.7	V	3.0	49.3	35.4	1.0	-51.8	-13.0	-38.8	
High Ch										
3.818	-59.8	H	3.0	45.7	35.3	1.0	-48.4	-13.0	-35.4	
5.726	-63.4	H	3.0	50.3	35.4	1.0	-47.5	-13.0	-34.5	
3.818	-62.0	V	3.0	45.4	35.3	1.0	-50.9	-13.0	-37.9	
5.726	-65.6	V	3.0	49.4	35.4	1.0	-50.7	-13.0	-37.7	
Rev. 03.03.09 Note: No other emissions were detected above the system noise floor.										

CDMA2000 1xEV-DO Revision A (Rev. A) Mode (PCS Band)

Compliance Certification Services
 Above 1GHz High Frequency Substitution Measurement

Company: Apple
 Project #: 10U13473
 Date: 11/16/10
 Test Engineer: Chin Pang
 Configuration: EUT (SEMCO) with Earphone and AC Adapter
 Mode: TX, EVDO-Rev A, PCS band

Chamber

Pre-amplifier

Filter

Limit

5m Chamber B

T145 8449B

Filter 1

Part 24

f GHz	SA reading (dBm)	Ant. Pol. (H/V)	Distance (m)	Path Loss (dB)	Preamp (dB)	Filter (dB)	EIRP (dBm)	Limit (dBm)	Delta (dB)	Notes
Low Ch										
3.702	-64.4	H	3.0	45.3	35.4	1.0	-53.4	-13.0	-40.4	
5.554	-64.2	H	3.0	50.0	35.4	1.0	-48.6	-13.0	-35.6	
3.702	-63.0	V	3.0	45.1	35.4	1.0	-52.2	-13.0	-39.2	
5.554	-65.0	V	3.0	49.2	35.4	1.0	-50.2	-13.0	-37.2	
Mid Ch										
3.761	-63.0	H	3.0	45.5	35.3	1.0	-51.8	-13.0	-38.8	
5.640	-65.0	H	3.0	50.2	35.4	1.0	-49.3	-13.0	-36.3	
3.761	-65.0	V	3.0	45.3	35.3	1.0	-54.1	-13.0	-41.1	
5.640	-67.0	V	3.0	49.3	35.4	1.0	-52.1	-13.0	-39.1	
High Ch										
3.818	-60.8	H	3.0	45.7	35.3	1.0	-49.4	-13.0	-36.4	
5.726	-66.6	H	3.0	50.3	35.4	1.0	-50.7	-13.0	-37.7	
3.818	-62.3	V	3.0	45.4	35.3	1.0	-51.2	-13.0	-38.2	
5.726	-65.0	V	3.0	49.4	35.4	1.0	-50.1	-13.0	-37.1	

Rev. 03.03.09
 Note: No other emissions were detected above the system noise floor.