

MEASUREMENT REPORT
FCC PART 15.519 / ISED RSS-220 Ultra-Wideband

Applicant Name:

Apple Inc.
One Apple Park Way
Cupertino, CA 95014
United States

Date of Testing:

6/12/2024 - 7/19/2024

Test Report Issue Date:

8/9/2024

Test Site/Location:

Element Materials Technology Morgan Hill, CA, USA

Test Report Serial No.:

1C2405230020-11.BCG

FCC ID:	BCG-A2999
IC:	579C-A2999
APPLICANT:	Apple Inc.

Application Type:

Certification

Model/HVIN:

A2999, A3000

EUT Type:

Watch

Operational Frequency:

6489.6MHz (Ch 5) and 7987.2MHz (Ch 9)

FCC Classification:

Ultra-Wideband Transmitter (UWB)

FCC Rule Part(s):

Part 15 Subpart F (15.519)

ISED Specification:

RSS-220 Issue 1 and RSS-Gen Issue 5

RSS 220 Subclass:

Hand-held Communication Devices

Test Procedures:

ANSI C63.10-2020, KDB 393764 D01 v02r01

This equipment has been shown to be capable of compliance with the applicable technical standards as indicated in the measurement report and was tested in accordance with the measurement procedures specified in ANSI C63.10-2020 and KDB 393764 D01 v02r01. Test results reported herein relate only to the item(s) tested.

I attest to the accuracy of data. All measurements reported herein were performed by me or were made under my supervision and are correct to the best of my knowledge and belief. I assume full responsibility for the completeness of these measurements and vouch for the qualifications of all persons taking them.



RJ Ortanez
Executive Vice President

Prepared by: WKR0000010245

Reviewed by: WKR0000005849



FCC ID: BCG-A2999 IC: 579C-A2999		MEASUREMENT REPORT (CERTIFICATION)	Approved by: Technical Manager
Test Report S/N: 1C2405230020-11.BCG	Test Dates: 6/12/2024 - 7/19/2024	EUT Type: Watch	Page 1 of 63

T A B L E O F C O N T E N T S

1.0	INTRODUCTION	3
1.1	Scope	3
1.2	Element Materials Technology Test Location	3
1.3	Test Facility / Accreditations	3
2.0	PRODUCT INFORMATION.....	4
2.1	Equipment Description	4
2.2	Device Capabilities.....	4
2.3	Antenna Description	6
2.4	Test Support Equipment.....	7
2.5	Test Configuration	7
2.6	Software and Firmware	8
2.7	EMI Suppression Device(s)/Modifications.....	8
3.0	DESCRIPTION OF TESTS	9
3.1	Evaluation Procedure	9
3.2	AC Line Conducted Emissions.....	9
3.3	Radiated Emissions.....	10
3.4	Environmental Conditions	10
4.0	ANTENNA REQUIREMENTS	11
5.0	MEASUREMENT UNCERTAINTY	12
6.0	TEST EQUIPMENT CALIBRATION DATA	13
7.0	TEST RESULTS.....	14
7.1	Summary	14
7.2	10dBc Bandwidth Measurement	15
7.3	Bandwidth Measurement.....	19
7.4	Maximum Peak and Average Radiated Power (EIRP)	23
7.5	Cease Transmission Time.....	29
7.6	Radiated Spurious Emissions Measurements – Above 960MHz.....	34
7.7	Radiated Spurious Emissions Measurements – Below 960MHz	52
7.8	AC Line-Conducted Emission Measurement	57
8.0	CONCLUSION.....	63

FCC ID: BCG-A2999 IC: 579C-A2999		MEASUREMENT REPORT (CERTIFICATION)	Approved by: Technical Manager
Test Report S/N: 1C2405230020-11.BCG	Test Dates: 6/12/2024 - 7/19/2024	EUT Type: Watch	Page 2 of 63

1.0 INTRODUCTION

1.1 Scope

Measurement and determination of electromagnetic emissions (EMC) of radio frequency devices including intentional and/or unintentional radiators for compliance with the technical rules and regulations of the Federal Communications Commission and the Innovation, Science and Economic Development Canada.

1.2 Element Materials Technology Test Location

These measurement tests were conducted at the Element Materials Technology facility located at 18855 Adams Court, Morgan Hill, CA 95037. The measurement facility is compliant with the test site requirements specified in ANSI C63.4-2014 and KDB 414788 D01 v01r01.

1.3 Test Facility / Accreditations

Measurements were performed at Element Materials Technology.

- Element Materials Technology is an ISO 17025-2017 accredited test facility under the American Association for Laboratory Accreditation (A2LA) with Certificate number 2041.02 for Specific Absorption Rate (SAR), Hearing Aid Compatibility (HAC) testing, where applicable, and Electromagnetic Compatibility (EMC) testing for FCC and Innovation, Science, and Economic Development Canada rules.
- Element Washington DC LLC TCB is a Telecommunication Certification Body (TCB) accredited to ISO/IEC 17065-2012 by A2LA (Certificate number 2041.03) in all scopes of FCC Rules and ISED Standards (RSS).
- Element Materials Technology facility is a registered (22831) test laboratory with the site description on file with ISED.
- Element Washington DC LLC is a Recognized U.S. Certification Assessment Body (CAB # US0110) for ISED Canada as designated by NIST under the U.S. and Canada Mutual Recognition Agreements (MRAs).

FCC ID: BCG-A2999 IC: 579C-A2999	 MEASUREMENT REPORT (CERTIFICATION)		Approved by: Technical Manager
Test Report S/N: 1C2405230020-11.BCG	Test Dates: 6/12/2024 - 7/19/2024	EUT Type: Watch	Page 3 of 63

2.0 PRODUCT INFORMATION

2.1 Equipment Description

The Equipment Under Test (EUT) is the **Apple Watch FCC ID: BCG-A2999** and **IC: 579C-A2999**. The test data contained in this report pertains only to the emissions due to the EUT's Ultra-Wideband (UWB) transmitter.

Test Device Serial No.: W0T3KGP227, FVMM2FCXPQ, QX0FRF41C6

2.2 Device Capabilities

This device contains the following capabilities:

802.11b/g/n WLAN, 802.11a/n UNII, 802.15.4 ab-NB, Bluetooth (1x, EDR, HDR4, HDR8, LE1M, LE2M), NFC, UWB, 60.5GHz Transmitter

For ISSED, this device is under subclass 5.3 Hand-held Communication Devices of RSS-220

Data Port UWB Radio Terminal Access: No

Ch.	Frequency (MHz)	Config	Payload	Config	Payload	Config	Payload
5	6500	0	25	703	0	811	0
		1	45	704	0	812	0
		6	125	705	0		
		10	25	706	0		
		11	25	405	4093		
			65	407	4093		
		101	25	409	4093		
			65	801	0 Gap0		
		102	25		0 Gap64		
			65	802	0		
		103	25	803	0		
			125	804	0 Gap0		
		202	625		0 Gap64		
		402	445	805	0		
		501	0	806	0		
		503	0	807	0 Gap0		
		601	0		0 Gap64		
		605	0	808	0		
		607	0	809	0		
		701	0	810	0 Gap0		
702	0	0 Gap64					

Table 2-1. UWB Frequency / Channel 5 Operations

FCC ID: BCG-A2999 IC: 579C-A2999		MEASUREMENT REPORT (CERTIFICATION)	Approved by: Technical Manager
Test Report S/N: 1C2405230020-11.BCG	Test Dates: 6/12/2024 - 7/19/2024	EUT Type: Watch	Page 4 of 63

Ch.	Frequency (MHz)	Config	Payload	Config	Payload	Config	Payload
9	8000	0	25	703	0	811	0
		1	45	704	0	812	0
		6	125	705	0		
		10	25	706	0		
		11	25	405	4093		
			65	407	4093		
		101	25	409	4093		
			65	801	0 Gap0		
		102	25		0 Gap64		
			65	802	0		
		103	25	803	0		
			125	804	0 Gap0		
		202	625		0 Gap64		
		402	445	805	0		
		501	0	806	0		
		503	0	807	0 Gap0		
		601	0		0 Gap64		
		605	0	808	0		
		607	0	809	0		
		701	0	810	0 Gap0		
702	0	0 Gap64					

Table 2-2. UWB Frequency / Channel 9 Operations

FCC ID: BCG-A2999 IC: 579C-A2999		MEASUREMENT REPORT (CERTIFICATION)	Approved by: Technical Manager
Test Report S/N: 1C2405230020-11.BCG	Test Dates: 6/12/2024 - 7/19/2024	EUT Type: Watch	Page 5 of 63

Notes:

1. All above configurations from Tables 2-1 & 2-2 were tested and only the worse case configurations were reported. For all possible packet types on device, please refer to Technical Description document
2. This device supports simultaneous multi radio transmission feature, which allows multiple radios to transmit simultaneously at the same antenna. The table below shows all the possible multi radio TX combinations:

Simultaneous Tx Config	Antenna FCM				
	WLAN	Bluetooth	802.15.4ab - NB	UNII	UWB
	802.11 b/g/n	BDR, EDR, HDR4/8, LE1/2M	O-QPSK	802.11 a/n	Ch.5/Ch.9
Config 1	✓	✗	✗	✗	✓
Config 2	✗	✓	✗	✗	✓
Config 3	✗	✓	✓	✗	✗
Config 4	✓	✗	✓	✗	✗
Config 5	✗	✓	✗	✓	✗

Table 2-3. Simultaneous Transmission Configurations

✓ = Support; ✗ = NOT Support

3. All above simultaneous transmission configurations have been tested and the worst case configuration was found to be configuration 5 (BT and UNII). These results can be found in the RF Bluetooth, RF UNII reports.

2.3 Antenna Description

Following antenna gains provided by manufacturer was used for the testing.

Frequency [MHz]	Antenna Gain (dBi)
6250-6750	-3.3
7750-8250	-2.6

Table 2-4. Highest Antenna Gain

FCC ID: BCG-A2999 IC: 579C-A2999		MEASUREMENT REPORT (CERTIFICATION)	Approved by: Technical Manager
Test Report S/N: 1C2405230020-11.BCG	Test Dates: 6/12/2024 - 7/19/2024	EUT Type: Watch	Page 6 of 63

2.4 Test Support Equipment

1	Apple Macbook	Model:	A1398	S/N:	FVFDHG8TP3XY
	w/AC/DC Adapter	Model:	A1435	S/N:	N/A
2	Apple USB-C cable	Model:	N/A	S/N:	N/A
	w/ Charging Dock	Model:	A3276	S/N:	DQ812910CU008V22F
	w/ Cradle	Model:	N/A	S/N:	CYV10420060A2LE03MP2C
3	Apple Magnetic Charger	Model:	A2515	S/N:	DLC310307CD1NR1AM
	Apple Magnetic Charger	Model:	A2879	S/N:	DLCH5T000ZM00000WB
4	Pathfinder Mocha X3100	Model:	920-13353-01	S/N:	DLCGMW0007D00000N7
	SiP Socket	Model:	P1 N20X B PF 307	S/N:	FN6GUA000JD00000M7
5	DC Power Supply	Model:	KPS3010D	S/N:	N/A
6	Store Sample Wristband	Model:	N/A	S/N:	DLC316300CU1QGKA2

Table 2-5. Test Support Equipment Used

2.5 Test Configuration

The EUT was tested per the guidance of ANSI C63.10-2020 and KDB 393764 D01 v02r01. ANSI C63.10-2020 was used to reference the appropriate EUT setup for radiated spurious emissions testing and AC line conducted testing. See Sections 3.2 for AC line conducted emissions test setups, 3.3 for radiated emissions test setups.

The worst case configuration was investigated with various types of wristbands, metal and non-metal wristbands. The EUT was also investigated with and without wireless charger. The worst case configuration found was used for all testing.

For emissions from 960MHz – 18GHz, channel 5 and channel 9 were tested with highest power and worst case configuration. The emissions below 960MHz and above 18GHz were tested with the highest transmitting power and the worst case configuration.

The EUT was manipulated through three orthogonal planes of X-orientation (flatbed), Y-orientation (landscape), and Z-orientation (portrait) during the testing. Only the worst case emissions were reported in this test report.

For AC line conducted emission and radiated test below 960MHz, following configuration were investigated and the worst case was reported.

- EUT powered by AC/DC adaptor via USB-C cable with magnetic charger
- EUT powered by host PC via USB-C cable with magnetic charger

FCC ID: BCG-A2999 IC: 579C-A2999		MEASUREMENT REPORT (CERTIFICATION)	Approved by: Technical Manager
Test Report S/N: 1C2405230020-11.BCG	Test Dates: 6/12/2024 - 7/19/2024	EUT Type: Watch	Page 7 of 63



2.6 Software and Firmware

The test was conducted with firmware version watchOS 11 installed on the EUT.

2.7 EMI Suppression Device(s)/Modifications

No EMI suppression device(s) were added and/or no modifications were made during testing.

FCC ID: BCG-A2999 IC: 579C-A2999		MEASUREMENT REPORT (CERTIFICATION)	Approved by: Technical Manager
Test Report S/N: 1C2405230020-11.BCG	Test Dates: 6/12/2024 - 7/19/2024	EUT Type: Watch	Page 8 of 63

V 10.5 12/15/2021

Unless otherwise specified, no part of this report may be reproduced or utilized in any part, form or by any means, electronic or mechanical, including photocopying and microfilm, without permission in writing from Element Materials Technology. If you have any questions about this or have an enquiry about obtaining additional rights to this report or assembly of contents thereof, please contact ct.info@element.com.

3.0 DESCRIPTION OF TESTS

3.1 Evaluation Procedure

The measurement procedures described in the American National Standard of Procedures for Compliance Testing of Unlicensed Wireless Devices (ANSI C63.10-2020) and the guidance provided in KDB 393764 D01 v02r01 were used in the measurement of the EUT.

Deviation from measurement procedure.....None

3.2 AC Line Conducted Emissions

The line-conducted facility is located inside a 7m x 3.66m x 2.7m shielded enclosure. The shielded enclosure is manufactured by AP Americas. The shielding effectiveness of the shielded room is in accordance with MIL-Std-285 or NSA 65-5. A 1m x 1.5m wooden table 80cm high is placed 40cm away from the vertical wall and 80cm away from the sidewall of the shielded room. Two 10kHz-30MHz, 50Ω/50μH Line-Impedance Stabilization Networks (LISNs) are bonded to the shielded room floor. Power to the LISNs is filtered by external high-current high-insertion loss power line filters. The external power line filter is EPCOS 2X60A Power Line Filter (100dB Attenuation, 14kHz-18GHz) and the two EPCOs 2X48A filters (100dB Minimum Insertion Loss, 14kHz – 10GHz). These filters attenuate ambient signal noise from entering the measurement lines. These filters are also bonded to the shielded enclosure.

The EUT is powered from one LISN and the support equipment is powered from the second LISN. If the EUT is a DC-powered device, power will be derived from the source power supply it normally will be powered from and this supply line(s) will be connected to the second LISN. All interconnecting cables more than 1 meter were shortened to a 1 meter length by non-inductive bundling (serpentine fashion) and draped over the back edge of the test table. All cables were at least 40cm above the horizontal reference groundplane. Power cables for support equipment were routed down to the second LISN while ensuring that that cables were not draped over the second LISN.

Sufficient time for the EUT, support equipment, and test equipment was allowed in order for them to warm up to their normal operating condition. The RF output of the LISN was connected to the spectrum analyzer and exploratory measurements were made to determine the frequencies producing the maximum emission from the EUT. The spectrum was scanned from 150kHz to 30MHz with a spectrum analyzer. The detector function was set to peak mode for exploratory measurements while the bandwidth of the analyzer was set to 10kHz. The EUT, support equipment, and interconnecting cables were arranged and manipulated to maximize each emission. Once the worst case emissions have been identified, the one EUT cable configuration/arrangement and mode of operation that produced these emissions is used for final measurements on the same test site. The analyzer is set to CISPR quasi-peak and average detectors with a 9kHz resolution bandwidth for final measurements.

Line conducted emissions test results are shown in Section 7.8. Automated test software was used to perform the AC line conducted emissions testing. Automated measurement software utilized is Rohde & Schwarz EMC32, Version 10.50.40.

FCC ID: BCG-A2999 IC: 579C-A2999	 MEASUREMENT REPORT (CERTIFICATION)		Approved by: Technical Manager
Test Report S/N: 1C2405230020-11.BCG	Test Dates: 6/12/2024 - 7/19/2024	EUT Type: Watch	Page 9 of 63

3.3 Radiated Emissions

The radiated test facilities consisted of an indoor 3 meter semi-anechoic chamber used for final measurements and exploratory measurements, when necessary. The measurement area is contained within the semi-anechoic chamber which is shielded from any ambient interference. The test site inside the chamber is a 6m x 5.2m elliptical, obstruction-free area in accordance with Figure 5.7 of Clause 5 in ANSI C63.4-2014. Absorbers are arranged on the floor between the turn table and the antenna mast in such a way so as to maximize the reduction of reflections for measurements above 1GHz. An 80cm tall test table made of Styrodur is placed on top of the turn table. For measurements above 1GHz, an additional Styrodur pedestal is placed on top of the test table to bring the total table height to 1.5m.

Per KDB 414788, radiated emission test sites other than open-field test sites (e.g., shielded anechoic chambers), may be employed for emission measurements below 30MHz if characterized so that the measurements correspond to those obtained at an open-field test site. To determine test site equivalency, a reference sample transmitting at 149kHz was measured on an open field test site (asphalt with no ground plane) and then measured in the 3m semi-anechoic chamber. A calibrated 60cm loop antenna was rotated about its vertical axis while the reference device was rotated through the X, Y and Z axis in order to capture the worst case level. A maximum deviation of 2.77dB at 149kHz was measured when comparing the 3 meter semi-anechoic chamber to the open field site.

For all measurements, the spectrum was scanned through all EUT azimuths and from 1 to 4 meter receive antenna height using a broadband antenna from 30MHz up to the upper frequency shown in 15.33 depending on the highest frequency generated or used in the device or on which the device operates or tunes. For frequencies above 1GHz, linearly polarized double ridge horn antennas were used. For frequencies below 30MHz, a calibrated loop antenna was used. When exploratory measurements were necessary, they were performed at 1 meter test distance inside the semi-anechoic chamber using broadband antennas, broadband amplifiers, and spectrum analyzers to determine the frequencies and modes producing the maximum emissions. Sufficient time for the EUT, support equipment, and test equipment was allowed in order for them to warm up to their normal operating condition. The test set-up was placed on top of the 1 x 1.5 meter table. The EUT, support equipment, and interconnecting cables were arranged and manipulated to maximize each emission. Appropriate precaution was taken to ensure that all emissions from the EUT were maximized and investigated. The system configuration, mode of operation, turntable azimuth, and receive antenna height was noted for each frequency found.

Final measurements were made in the semi-anechoic chamber using calibrated, linearly polarized broadband and horn antennas. The test setup was configured to the setup that produced the worst case emissions. The spectrum analyzer was set to investigate all frequencies required for testing to compare the highest radiated disturbances with respect to the specified limits. The turntable containing the EUT was rotated through 360 degrees and the height of the receive antenna was varied 1 to 4 meters and stopped at the azimuth and height producing the maximum emission. Each emission was maximized by changing the orientation of the EUT through three orthogonal planes and changing the polarity of the receive antenna, whichever produced the worst-case emissions.

3.4 Environmental Conditions

The temperature is controlled within range of 15°C to 35°C. The relative humidity is controlled within range of 10% to 75%. The atmospheric pressure is monitored within the range 86-106kPa (860-1060mbar).

FCC ID: BCG-A2999 IC: 579C-A2999	 MEASUREMENT REPORT (CERTIFICATION)		Approved by: Technical Manager
Test Report S/N: 1C2405230020-11.BCG	Test Dates: 6/12/2024 - 7/19/2024	EUT Type: Watch	Page 10 of 63

4.0 ANTENNA REQUIREMENTS

Excerpt from §15.203 of the FCC Rules/Regulations:

“An intentional radiator antenna shall be designed to ensure that no antenna other than that furnished by the responsible party can be used with the device. The use of a permanently attached antenna or of an antenna that uses a unique coupling to the intentional radiator shall be considered sufficient to comply with the provisions of this section.”

- The antenna(s) of the EUT are **permanently attached**.
- There are no provisions for connection to an external antenna.

Conclusion:

The EUT complies with the requirement of §15.203.

FCC ID: BCG-A2999 IC: 579C-A2999	 MEASUREMENT REPORT (CERTIFICATION)		Approved by: Technical Manager
Test Report S/N: 1C2405230020-11.BCG	Test Dates: 6/12/2024 - 7/19/2024	EUT Type: Watch	Page 11 of 63

V 10.5 12/15/2021

5.0 MEASUREMENT UNCERTAINTY

The measurement uncertainties shown below were calculated in accordance with the requirements of ANSI C63.23-2012. All measurement uncertainty values are shown with a coverage factor of $k = 2$ to indicate a 95% level of confidence. The measurement uncertainty shown below meets or exceeds the U_{CISPR} measurement uncertainty values specified in CISPR 16-4-2 and, thus, can be compared directly to specified limits to determine compliance.

Contribution	Expanded Uncertainty (\pm dB)
Conducted Bench Top Measurements	2.07
Line Conducted Disturbance	1.91
Radiated Disturbance (<30MHz)	4.12
Radiated Disturbance (30MHz - 1GHz)	4.85
Radiated Disturbance (1 - 18GHz)	5.08
Radiated Disturbance (>18GHz)	5.22

Parameter	Expanded Uncertainty
Time	$\pm 0.2\%$

FCC ID: BCG-A2999 IC: 579C-A2999		MEASUREMENT REPORT (CERTIFICATION)	Approved by: Technical Manager
Test Report S/N: 1C2405230020-11.BCG	Test Dates: 6/12/2024 - 7/19/2024	EUT Type: Watch	Page 12 of 63

V 10.5 12/15/2021

6.0 TEST EQUIPMENT CALIBRATION DATA

Test Equipment Calibration is traceable to the National Institute of Standards and Technology (NIST). Measurements antennas used during testing were calibrated in accordance to the requirements of ANSI C63.5-2017.

Manufacturer	Model	Description	Cal Date	Cal Interval	Cal Due	Serial Number
Agilent Technologies	N9030A	3Hz-26.5GHz PXA Signal Analyzer	10/18/2023	Annual	10/18/2024	MY55330128
Anritsu	ML2495A	Power Meter	7/8/2024	Annual	7/8/2025	1039008
Anritsu	MA2411B	Pulse Power Sensor	7/1/2024	Annual	7/1/2025	1911105
Anritsu	MA2411B	Pulse Power Sensor	11/8/2023	Annual	11/8/2024	1027293
ATM	180-442A-KF	20dB Nominal Gain Horn Antenna	3/14/2024	Annual	3/14/2025	T058701-01
ETS-Lindgren	3117	Double Ridged Guide Antenna (1-18 GHz)	4/9/2024	Annual	4/9/2025	00218555
Keysight Technology	N9040B	UXA Signal Analyzer	5/28/2024	Annual	5/28/2025	MY57212015
Mini-Circuits	FLC-1.5FT-SMSM+	30MHz-27GHz Conducted Cable *	9/14/2023	Annual	9/14/2024	16113316
Rohde & Schwarz	TS-PR18	Pre-Amplifier (1GHz - 18GHz)	8/15/2023	Annual	8/15/2024	101639
Rohde & Schwarz	FSV40	Signal Analyzer (10Hz-40GHz)	5/29/2024	Annual	5/29/2025	101619
Rohde & Schwarz	ESW44	EMI Test Receiver	5/1/2024	Annual	5/1/2025	101867
Rohde & Schwarz	TS-PR8	Pre-Amplifier (30MHz - 8GHz)	7/3/2024	Annual	7/3/2025	102356
Rohde & Schwarz	TS-PR1840	Pre-Amplifier (18GHz - 40GHz)	6/10/2024	Annual	6/10/2025	100057
Rohde & Schwarz	HFH2-Z2	Loop Antenna	6/21/2024	Annual	6/21/2025	100519
Rohde & Schwarz	ENV216	Two-Line V-Network	7/12/2024	Annual	7/12/2025	101363
Schwarzbeck	VULB 9162	Bilog Antenna (30MHz - 6GHz)	4/29/2024	Annual	4/29/2025	00304

Table 6-1. Test Equipment List

Note:

- For equipment listed above that has a calibration date or calibration due date that falls within the test date range, care was taken to ensure that this equipment was used after the calibration date and before the calibration due date.
- * denotes passive equipment that have been internally verified/calibrated.

FCC ID: BCG-A2999 IC: 579C-A2999		MEASUREMENT REPORT (CERTIFICATION)	Approved by: Technical Manager
Test Report S/N: 1C2405230020-11.BCG	Test Dates: 6/12/2024 - 7/19/2024	EUT Type: Watch	Page 13 of 63

7.0 TEST RESULTS

7.1 Summary

Company Name: Apple Inc.
 FCC ID: BCG-A2999
 IC: 579C-A2999
 FCC Classification: Ultra-Wideband Transmitter

FCC Part Section(s)	RSS Section(s)	Test Description	Test Limit	Test Condition	Test Result	Reference
§15.503, §15.519 (b)	RSS-220 [2]	10dBc Bandwidth	≥ 500MHz	RADIATED	PASS	Section 7.2, 7.3
§ 2.1049	RSS-Gen [6.7]	Occupied Bandwidth	N/A		N/A	Section 7.3
§15.519 (e)	RSS-220 [5.3.1(g)]	Maximum Peak Power Spectral Density (Peak EIRP)	< 0 dBm/50MHz EIRP		PASS	Sections 7.4.1
§15.519 (c)	RSS-220 [5.3.1(d)]	Maximum Average Emission (Average EIRP)	< -41.3 dBm/MHz EIRP		PASS	Section 7.4.2
§15.519 (a)(1)	RSS-220 [5.3.1(b)]	Cease Transmission Time	See §15.519 (a)(1) and RSS-220 [5.3.1(b)] for details		PASS	Section 7.5
§15.519 (c)	RSS-220 [5.3.1(d)]	Radiated Emissions Above 960MHz	See table in §15.519 (c) and RSS-220[5.3.1(d)] for details		PASS	Sections 7.6
§15.519 (d)	RSS-220 [5.3.1(e)]	Radiated Emissions in the 1164 – 1240Mhz and 1559 – 1610MHz GPS Bands	See §15.519 (d) and RSS-220 [5.3.1 (e)] for details		PASS	Sections 7.6
§15.519 (c), §15.209	RSS-220 [3.4] RSS-Gen [8.9]	Radiate Emissions Below 960MHz	Emissions in restricted bands must meet the radiated limits detailed in §15.209 (RSS-Gen [8.9])		PASS	Section 7.7
§15.207	RSS-Gen [8.8]	AC Line Conducted Emissions 150kHz – 30MHz	< FCC 15.207 limits (RSS-Gen [8.8])	AC LINE CONDUCTED	PASS	Section 7.8

Table 7-1. Summary of Test Results

Notes:

- All modes of operation were investigated. The test results shown in the following sections represent the worst case emissions.
- The analyzer plots shown in this section were all taken with a correction table loaded into the analyzer. The correction table was used to account for the losses of the cables and attenuators used as part of the system to connect the EUT to the analyzer at all frequencies of interest.
- For radiated emissions, automated test software was used to measure emissions and capture the corresponding plots necessary to show compliance. The measurement software utilized is Element “Chamber Automation,” Version 3.0.0.

FCC ID: BCG-A2999 IC: 579C-A2999		MEASUREMENT REPORT (CERTIFICATION)	Approved by: Technical Manager
Test Report S/N: 1C2405230020-11.BCG	Test Dates: 6/12/2024 - 7/19/2024	EUT Type: Watch	Page 14 of 63



7.2 10dBc Bandwidth Measurement §15.503 §15.519 (b)

Test Overview and Limit

The UWB bandwidth is the frequency band bounded by the points that are 10dB below the highest radiated emission, as based on the complete transmission system including the antenna. The upper boundary is designated F_H and the lower boundary is designated F_L . The frequency at which the highest radiated emission occurs is designated F_M .

- The center frequency, F_C , equals $(F_H + F_L)/2$
- The fractional bandwidth equals $2(F_H - F_L) / (F_H + F_L)$

The UWB bandwidth of a device operating under the provisions of this section must be contained between 3100MHz and 10,600MHz.

- a) *The minimum permissible 10dBc Bandwidth is 500 MHz*
- b) *Fractional bandwidth is equal or greater than 0.20*

Test Procedure Used

ANSI C63.10-2020 – Section 10.1
KDB 393764 D01 v02r01

Test Settings

1. RBW = 1MHz
2. VBW = 3MHz
3. Detector = Peak
4. Trace mode = max hold
5. Sweep = auto couple
6. The trace was allowed to stabilize

FCC ID: BCG-A2999 IC: 579C-A2999		MEASUREMENT REPORT (CERTIFICATION)	Approved by: Technical Manager
Test Report S/N: 1C2405230020-11.BCG	Test Dates: 6/12/2024 - 7/19/2024	EUT Type: Watch	Page 15 of 63

V 10.5 12/15/2021

Test Setup

The EUT and measurement equipment were set up as shown in the diagram below.

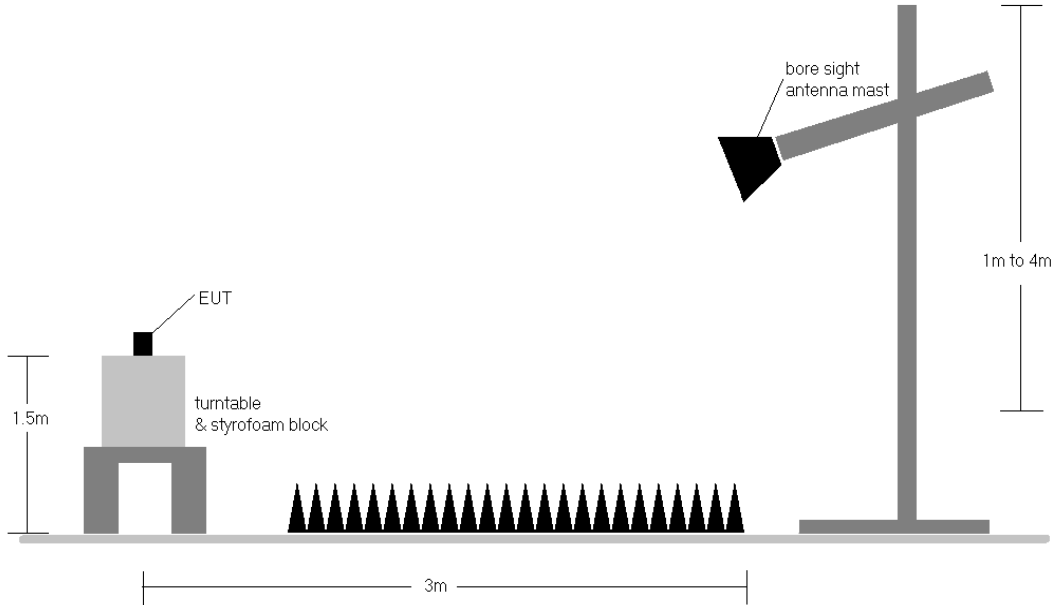

Figure 7-1. Test Setup

Test Notes

1. In those cases where the measured emission spectrum contains multiple (more than two) -10dBc points, the outermost points define the UWB bandwidth (i.e., the widest bandwidth is reported).
2. All modes of operation were investigated and the worst-case emissions are reported.

FCC ID: BCG-A2999 IC: 579C-A2999	 MEASUREMENT REPORT (CERTIFICATION)		Approved by: Technical Manager
Test Report S/N: 1C2405230020-11.BCG	Test Dates: 6/12/2024 - 7/19/2024	EUT Type: Watch	Page 16 of 63

Frequency [GHz]	Channel	Config	Payload	F _M [GHz]	F _L [GHz]	F _H [GHz]	F _c [GHz]	Measured Bandwidth [MHz]	Minimum Bandwidth [MHz]	Pass / Fail
6.5	5	409	4093	6.25	6.226	6.753	6.4895	527.00	500	Pass

Table 7-2. 10dBc Bandwidth Measurements (UWB, Ch.5, 6.5GHz)

Frequency [GHz]	Channel	Config	Payload	F _M [GHz]	F _L [GHz]	F _H [GHz]	F _c [GHz]	Measured Bandwidth [MHz]	Minimum Bandwidth [MHz]	Pass / Fail
8	9	409	4093	7.987	7.724	8.251	7.9875	527.00	500	Pass

Table 7-3. 10dBc Bandwidth Measurements (UWB, Ch.9, 8GHz)

FCC ID: BCG-A2999 IC: 579C-A2999		MEASUREMENT REPORT (CERTIFICATION)		Approved by: Technical Manager
Test Report S/N: 1C2405230020-11.BCG	Test Dates: 6/12/2024 - 7/19/2024	EUT Type: Watch		Page 17 of 63

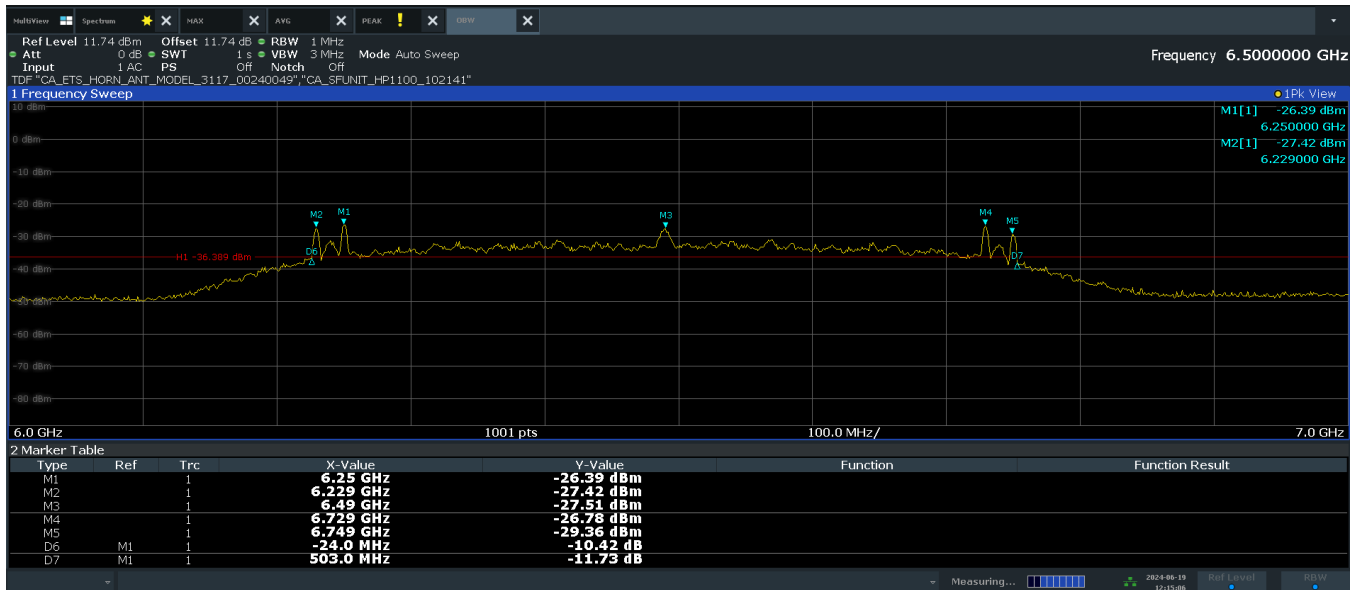

Plot 7-1. 10dBc Bandwidth (Ch. 5, Config 409/Payload 4093)

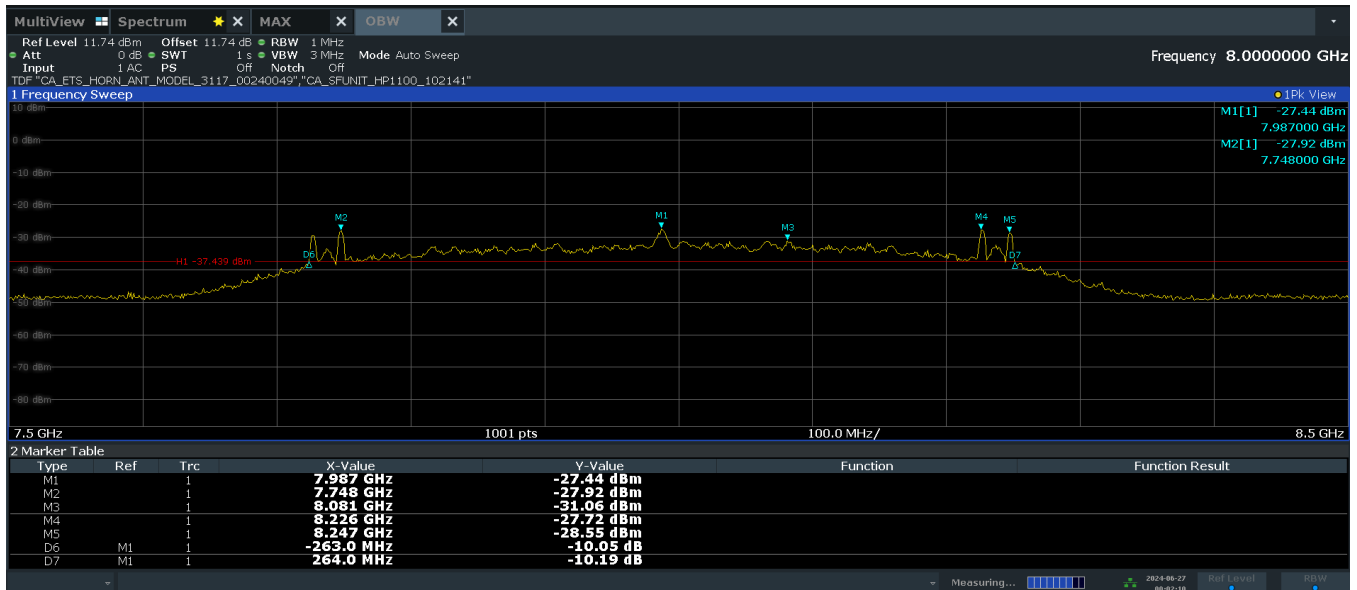

Plot 7-2. 10dBc Bandwidth (Ch. 9, Config 409/Payload 4093)

FCC ID: BCG-A2999 IC: 579C-A2999		MEASUREMENT REPORT (CERTIFICATION)	Approved by: Technical Manager
Test Report S/N: 1C2405230020-11.BCG	Test Dates: 6/12/2024 - 7/19/2024	EUT Type: Watch	Page 18 of 63

7.3 Bandwidth Measurement

RSS-220 [2], RSS-Gen [6.7]

Test Overview and Limit

The occupied bandwidth, that is the frequency bandwidth such that, below its lower and above its upper frequency limits, the mean powers radiated are each equal to 0.5 percent of the total mean power radiated by a given emission shall be measured. All modes of operation were investigated and the worst case configuration results are reported in this section.

Test Procedure Used

ANSI C63.10-2020 – Section 6.9
RSS-Gen [6.7]

Test Settings

1. The signal analyzer’s automatic bandwidth measurement capability was used to perform the 99% occupied bandwidth and the 10dB bandwidth. The bandwidth measurement was not influenced by any intermediate power nulls in the fundamental emission.
2. RBW = 1 – 5% of the expected OBW
3. VBW \geq 3 x RBW
4. Detector = Peak
5. Trace mode = max hold
6. Sweep = auto couple
7. The trace was allowed to stabilize
8. If necessary, steps 2 – 7 were repeated after changing the RBW such that it would be within 1 – 5% of the 99% occupied bandwidth observed in Step 7

FCC ID: BCG-A2999 IC: 579C-A2999	 MEASUREMENT REPORT (CERTIFICATION)	Approved by: Technical Manager
Test Report S/N: 1C2405230020-11.BCG		Test Dates: 6/12/2024 - 7/19/2024

Test Setup

The EUT and measurement equipment were set up as shown in the diagram below.

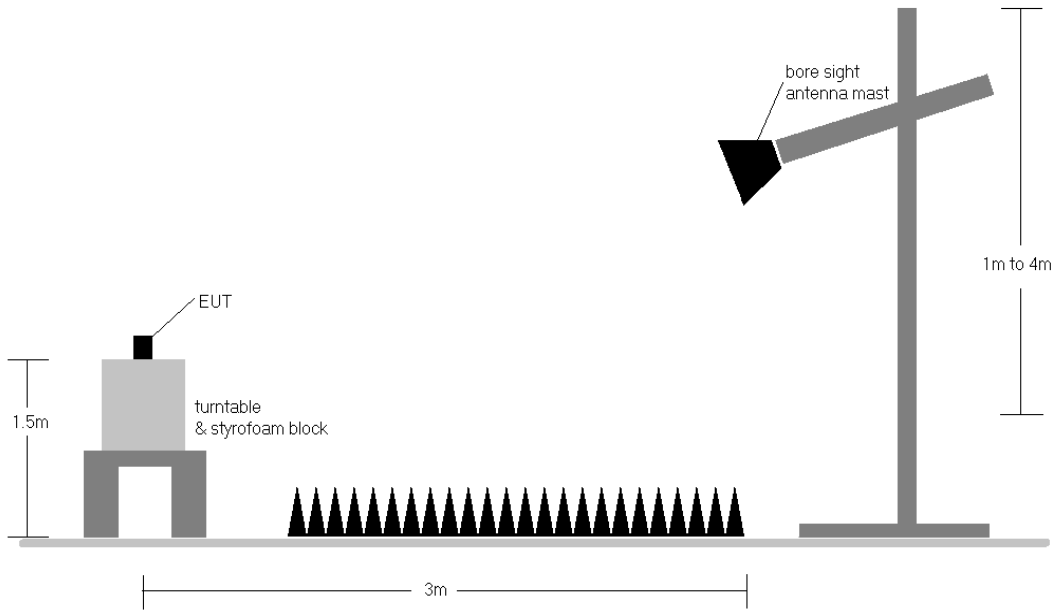

Figure 7-2. Test Instrument & Measurement Setup

Test Notes

1. All modes of operation were investigated and the worst-case emissions are reported.

FCC ID: BCG-A2999 IC: 579C-A2999	 MEASUREMENT REPORT (CERTIFICATION)		Approved by: Technical Manager
Test Report S/N: 1C2405230020-11.BCG	Test Dates: 6/12/2024 - 7/19/2024	EUT Type: Watch	Page 20 of 63

Frequency [GHz]	Channel	Config	Payload	Measured OBW [MHz]	Measured 10dBc Bandwidth	Minimum Bandwidth [MHz]	Pass / Fail
6.5	5	409	4093	602.22	528.20	500	Pass

Table 7-4. ISED 10dBc Bandwidth & 99% OBW Measurements (UWB, Ch.5, 6.5GHz)

Frequency [GHz]	Channel	Config	Payload	Measured OBW [MHz]	Measured 10dBc Bandwidth	Minimum Bandwidth [MHz]	Pass / Fail
8	9	409	4093	607.28	543.50	500	Pass

Table 7-5. ISED 10dBc Bandwidth & 99% OBW Measurements (UWB, Ch.9, 8GHz)

FCC ID: BCG-A2999 IC: 579C-A2999		MEASUREMENT REPORT (CERTIFICATION)	Approved by: Technical Manager
Test Report S/N: 1C2405230020-11.BCG	Test Dates: 6/12/2024 - 7/19/2024	EUT Type: Watch	Page 21 of 63

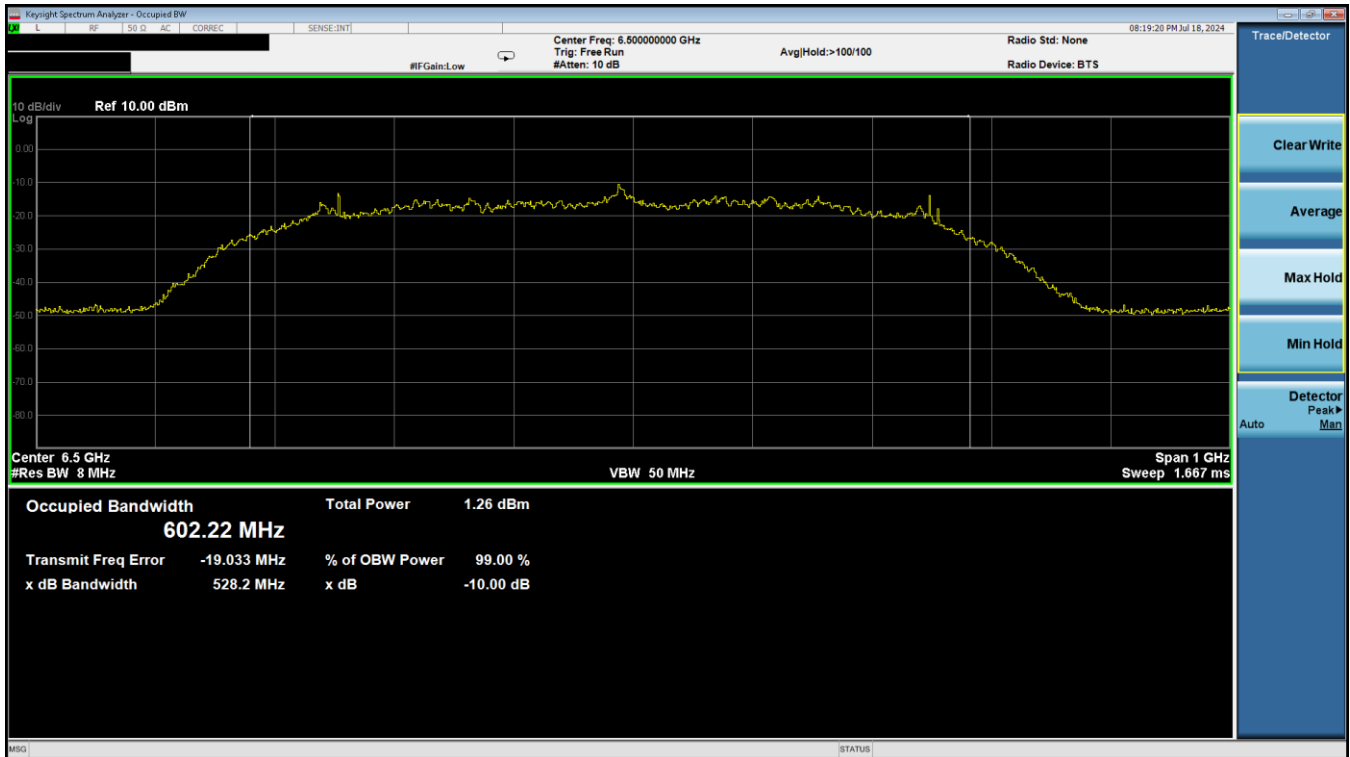

Plot 7-3. ISED 10dBc Occupied Bandwidth & 99% (Ch. 5, Config 409/Payload 4093)

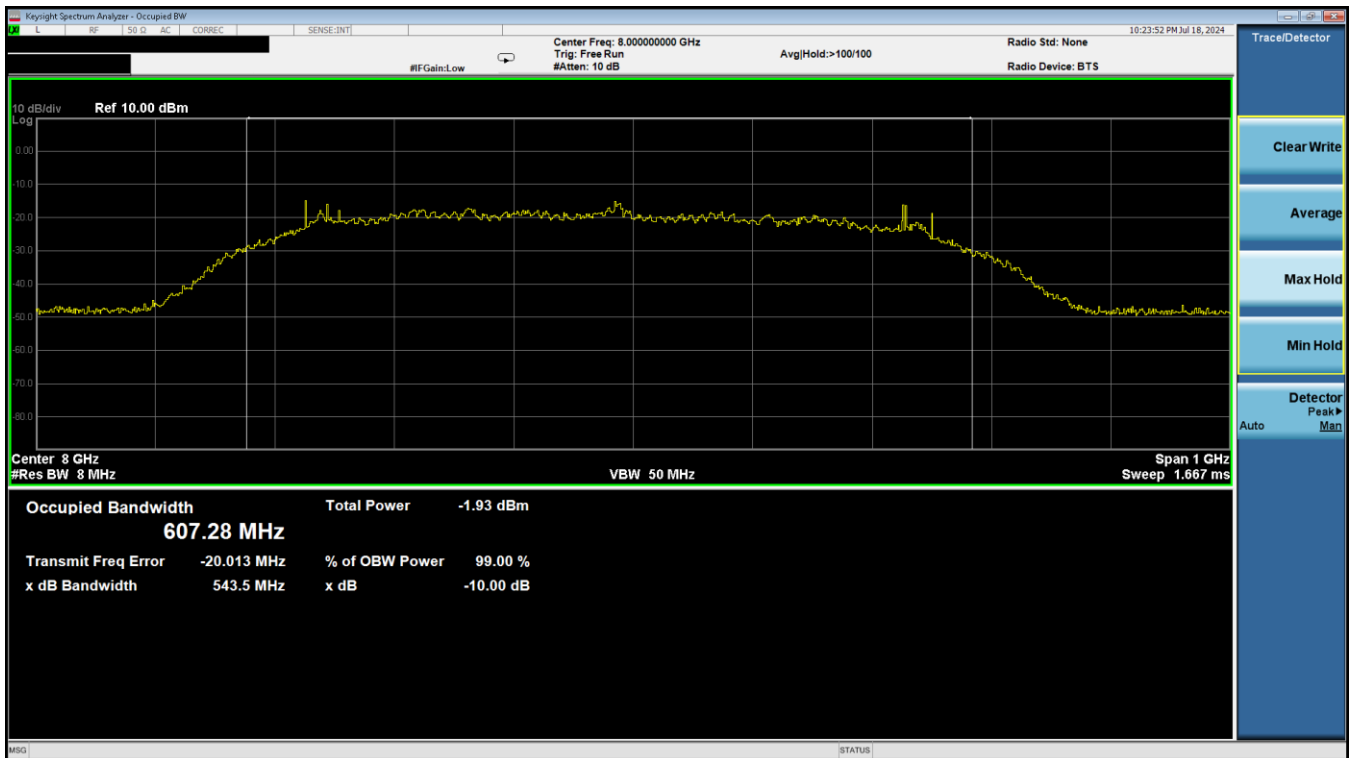

Plot 7-4. ISED 10dBc Occupied Bandwidth & 99 (Ch. 9, Config 409/Payload4093)

FCC ID: BCG-A2999 IC: 579C-A2999		MEASUREMENT REPORT (CERTIFICATION)	Approved by: Technical Manager
Test Report S/N: 1C2405230020-11.BCG	Test Dates: 6/12/2024 - 7/19/2024	EUT Type: Watch	Page 22 of 63

7.4 Maximum Peak and Average Radiated Power (EIRP)

§15.519 (c) §15.519 (e); RSS-220 [5.3.1(d)] RSS-220 [5.3.1(g)]

Test Overview and Limits

15.519 (e) There is a limit on the peak level of the emissions contained within a 50 MHz bandwidth centered on the frequency at which the highest radiated emission occurs, F_M . That limit is 0 dBm for Peak EIRP.

15.519 (c) The radiated emissions above 960 MHz from a device operating under the provisions of this section shall not exceed the following average limits when measured using a resolution bandwidth of 1 MHz:

Frequency [MHz]	EIRP [dBm]
3100-10600	-41.3

Table 7-6. FCC 15.519 Average EIRP limit

Frequency [MHz]	EIRP [dBm]
4750-10600	-41.3

Table 7-7. RSS-220 Average EIRP limit

Test Procedure Used

ANSI C63.10-2020 – Section 10.3.5 and 10.3.7
KDB 393764 D01 v02r01

Test Settings

Average EIRP Measurements

1. RBW = 1MHz
2. VBW = 3MHz
3. Detector = Average (RMS)
4. Sweep time = No more than a 1 ms integration period over each measurement bin
5. Trace mode = Max hold
6. Trace was allowed to stabilize

Peak EIRP Measurements

1. RBW = 50MHz
2. VBW = 50MHz
3. Detector = Peak
4. Sweep time = auto couple
5. Trace mode = Max hold
6. Trace was allowed to stabilize

FCC ID: BCG-A2999 IC: 579C-A2999		MEASUREMENT REPORT (CERTIFICATION)	Approved by: Technical Manager
Test Report S/N: 1C2405230020-11.BCG	Test Dates: 6/12/2024 - 7/19/2024	EUT Type: Watch	Page 23 of 63

V 10.5 12/15/2021

Test Setup

The EUT and measurement equipment were set up as shown in the diagram below.

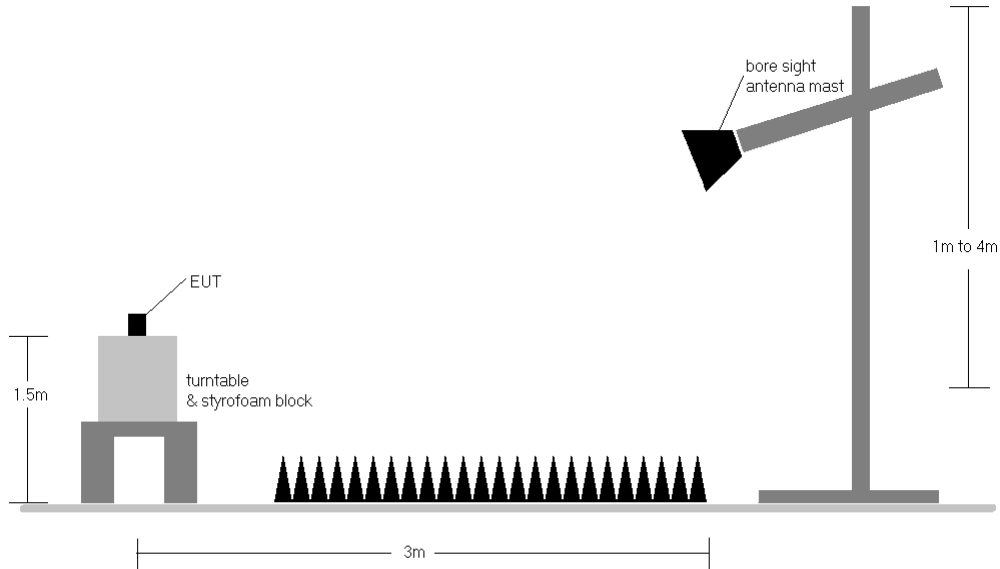

Figure 7-3. Test Instrument & Measurement Setup

Test Notes

1. The antenna is manipulated through typical positions, polarity and length during the tests. The EUT is manipulated through three orthogonal planes.
2. All modes of operation were investigated and the worst-case emissions are reported.

FCC ID: BCG-A2999 IC: 579C-A2999	 MEASUREMENT REPORT (CERTIFICATION)		Approved by: Technical Manager
Test Report S/N: 1C2405230020-11.BCG	Test Dates: 6/12/2024 - 7/19/2024	EUT Type: Watch	Page 24 of 63



7.4.1 Peak Radiated Power Measurement
§15.519(e); RSS-220 [5.3.1(g)]

Frequency [GHz]	Channel	Config	Payload	Ant. Pol. [H/V]	Antenna Height [cm]	Turntable Azimuth [degree]	F _M [GHz]	Peak EIRP [dBm/50MHz]	Peak EIRP Limit [dBm/50MHz]	Margin [dB]
6.5	5	409	4093	V	263	239	6.2384	-13.47	0.00	-13.47

Table 7-8. Peak EIRP Measurements (Channel 5)

Frequency [GHz]	Channel	Config	Payload	Ant. Pol. [H/V]	Antenna Height [cm]	Turntable Azimuth [degree]	F _M [GHz]	Peak EIRP [dBm/50MHz]	Peak EIRP Limit [dBm/50MHz]	Margin [dB]
8.0	9	409	4093	V	366	100	8.2527	-13.54	0.00	-13.54

Table 7-9. Peak EIRP Measurements (Channel 9)

FCC ID: BCG-A2999 IC: 579C-A2999		MEASUREMENT REPORT (CERTIFICATION)		Approved by: Technical Manager
Test Report S/N: 1C2405230020-11.BCG	Test Dates: 6/12/2024 - 7/19/2024	EUT Type: Watch		Page 25 of 63

V 10.5 12/15/2021

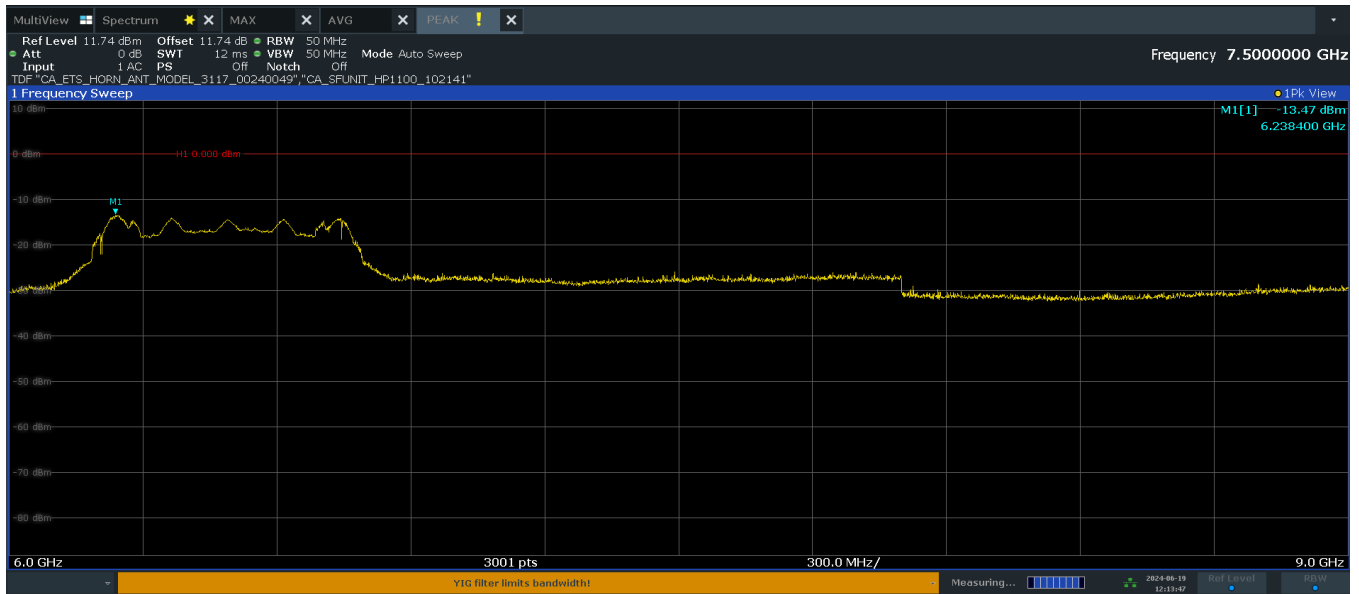

Plot 7-5. Peak Radiated Power (Ch. 5, Config 409/Payload 4093)

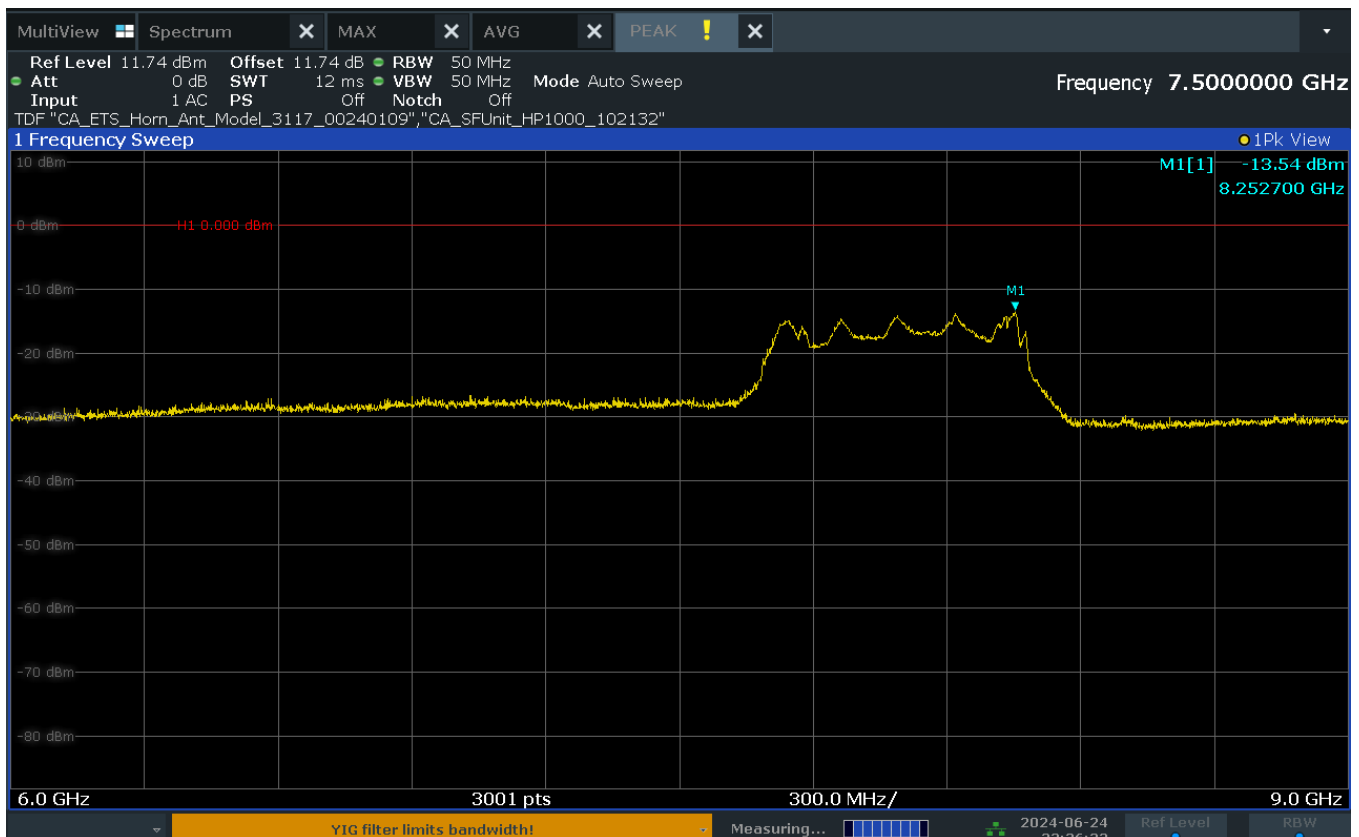

Plot 7-6. Peak Radiated Power (Ch. 9, Config 409/Payload 4093)

FCC ID: BCG-A2999 IC: 579C-A2999		MEASUREMENT REPORT (CERTIFICATION)	Approved by: Technical Manager
Test Report S/N: 1C2405230020-11.BCG	Test Dates: 6/12/2024 - 7/19/2024	EUT Type: Watch	Page 26 of 63



7.4.2 Average Radiated Power Measurement
§15.519(c); RSS-220 [5.3.1(d)]

Frequency [GHz]	Channel	Config	Payload	Ant. Pol. [H/V]	Antenna Height [cm]	Turntable Azimuth [degree]	F _M [GHz]	Average EIRP [dBm/1MHz]	Average EIRP Limit [dBm/1MHz]	Margin [dB]
6.5	5	409	4093	V	263	239	6.5323	-42.14	-41.30	-0.84

Table 7-10. Average EIRP Measurements (Channel 5)

Frequency [GHz]	Channel	Config	Payload	Ant. Pol. [H/V]	Antenna Height [cm]	Turntable Azimuth [degree]	F _M [GHz]	Average EIRP [dBm/1MHz]	Average EIRP Limit [dBm/1MHz]	Margin [dB]
8.0	9	409	4093	V	366	100	8.1448	-42.35	-41.30	-1.05

Table 7-11. Average EIRP Measurements (Channel 9)

FCC ID: BCG-A2999 IC: 579C-A2999		MEASUREMENT REPORT (CERTIFICATION)		Approved by: Technical Manager
Test Report S/N: 1C2405230020-11.BCG	Test Dates: 6/12/2024 - 7/19/2024	EUT Type: Watch		Page 27 of 63

V 10.5 12/15/2021

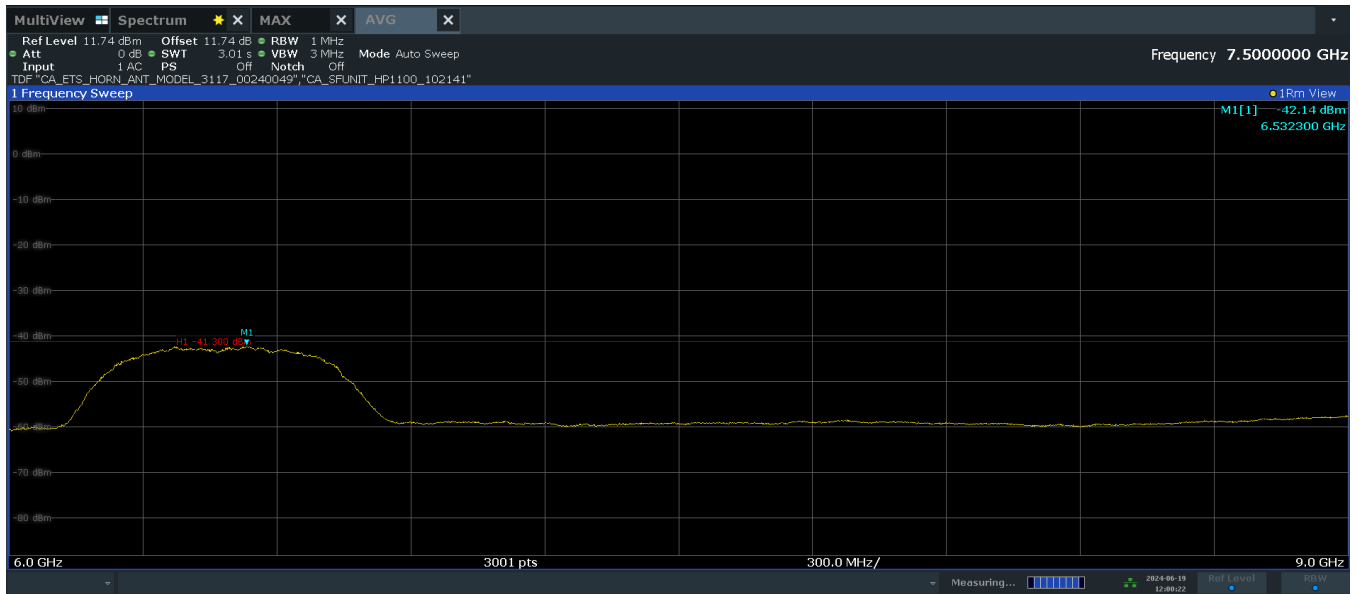

Plot 7-7. Average Radiated Power (Ch. 5, Config 409/Payload 4093)

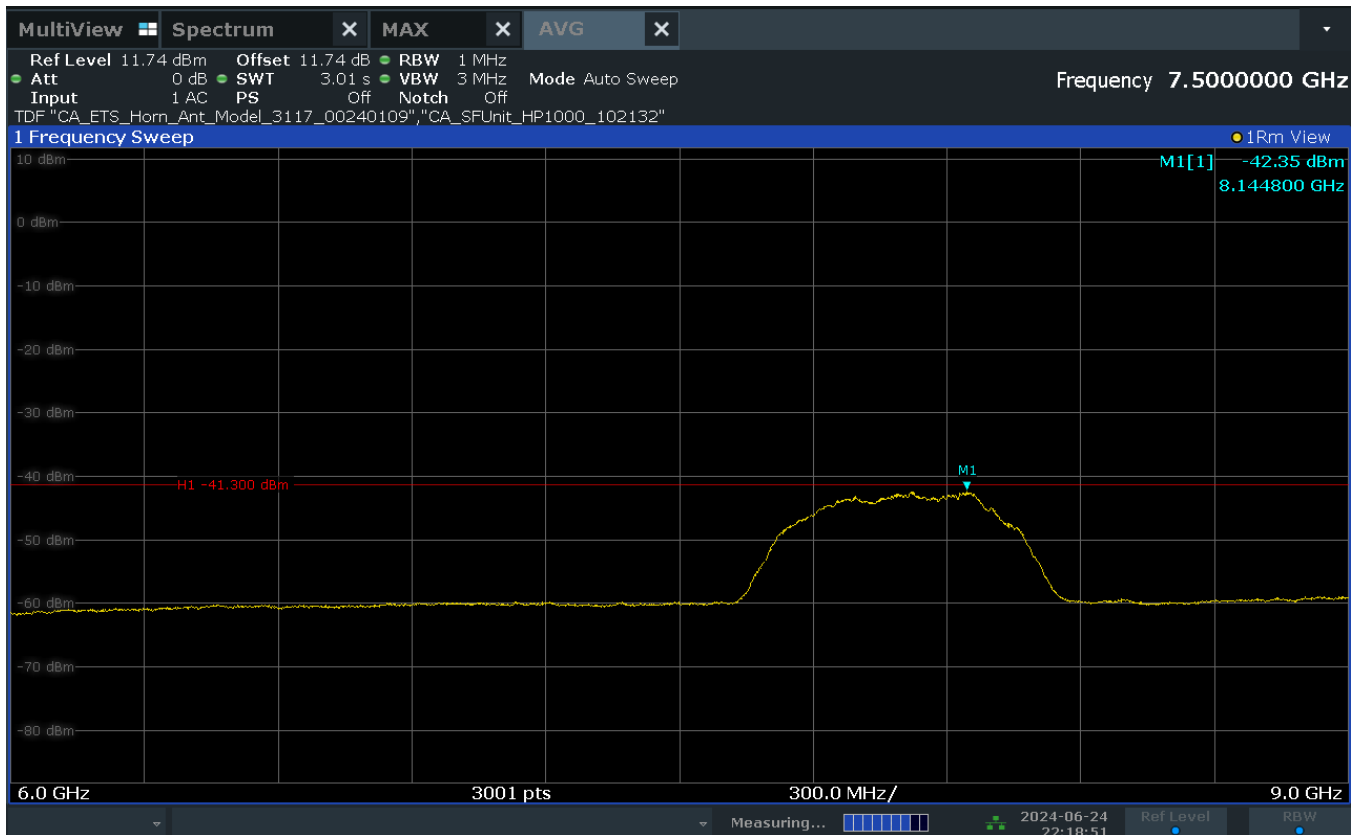

Plot 7-8. Average Radiated Power (Ch. 9, Config 409/Payload 4093)

FCC ID: BCG-A2999 IC: 579C-A2999		MEASUREMENT REPORT (CERTIFICATION)	Approved by: Technical Manager
Test Report S/N: 1C2405230020-11.BCG	Test Dates: 6/12/2024 - 7/19/2024	EUT Type: Watch	Page 28 of 63

7.5 Cease Transmission Time

§15.519(a)(1); RSS-220 [5.3.1(b)]

Test Overview and Limit

A UWB device operating under the provisions of this section shall transmit only when it is sending information to an associated receiver. The UWB intentional radiator shall cease transmission within 10 seconds unless it receives an acknowledgement from the associated receiver that its transmission is being received. An acknowledgment of reception must continue to be received by the UWB intentional radiator at least every 10 seconds or the UWB device must cease transmitting.

Test Procedures Used

KDB 393764 D01 v02r01

Test Settings

1. RBW = 1MHz
2. VBW = 3MHz
3. Span = Zero Span Mode
4. Sweep time shall be sufficient to demonstrate EUTs compliance with the rule part.

Test Setup

The EUT and measurement equipment were set up as shown in the diagram below.

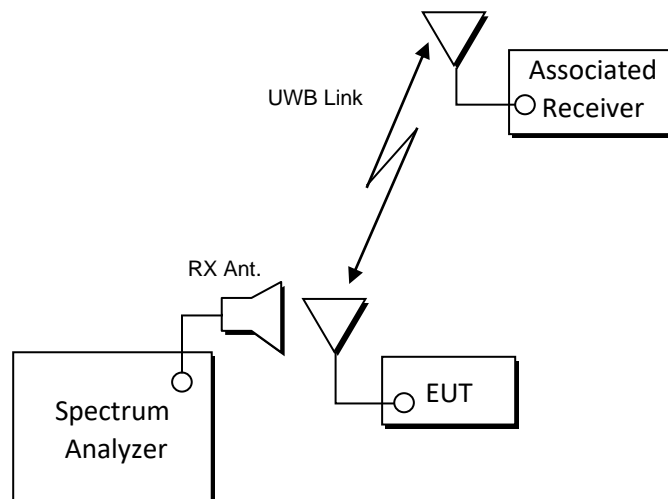

Figure 7-4. Test Setup

FCC ID: BCG-A2999 IC: 579C-A2999		MEASUREMENT REPORT (CERTIFICATION)	Approved by: Technical Manager
Test Report S/N: 1C2405230020-11.BCG	Test Dates: 6/12/2024 - 7/19/2024	EUT Type: Watch	Page 29 of 63

V 10.5 12/15/2021

Test Configurations

The EUT was monitored in 2 different test configurations:

- Mode 1: EUT initiates the UWB link to the associated receiver (phone),
 - Associated receiver ends the link, and EUT ceases transmission of any information other than periodic signals (polling) for use in the establishment or re-establishment of a communications link with an associated receiver
- Mode 2: The associated receiver (phone) initiates the UWB link to the EUT
 - EUT ends the link, and stops sending acknowledgements to associated receiver

Result

Parameter	Limit	Result
Cessation Time - Mode1	1) The UWB intentional radiator shall cease transmission within 10 seconds 2) An acknowledgment of reception must continue to be received by the UWB intentional radiator at least every 10 seconds or the UWB device must cease transmitting.	Pass
Cessation Time - Mode2	1) The UWB intentional radiator shall cease transmission within 10 seconds 2) An acknowledgment of reception must continue to be received by the UWB intentional radiator at least every 10 seconds or the UWB device must cease transmitting.	Pass

Plots Description

- Cessation Time - Mode1 (Mode2) plot:
 - Marker 1 shows stop time of sending acknowledgement from the associated receiver. UWB Transmission ceases promptly.
 - Marker 2 is placed to show that UWB Cease Tx has stopped before the maximum 10 s limit.
- Zoom in Cessation Time - Mode1 plot:
 - Marker 1 shows EUT traffic level
 - Marker 2 shows Associated receiver (Phone) traffic level
 - Marker 3 shows Associated receiver (Phone) Acknowledgement signal
 - Marker 4 shows EUT Polling signal (Before ceasing transmission)

FCC ID: BCG-A2999 IC: 579C-A2999		MEASUREMENT REPORT (CERTIFICATION)	Approved by: Technical Manager
Test Report S/N: 1C2405230020-11.BCG	Test Dates: 6/12/2024 - 7/19/2024	EUT Type: Watch	Page 30 of 63

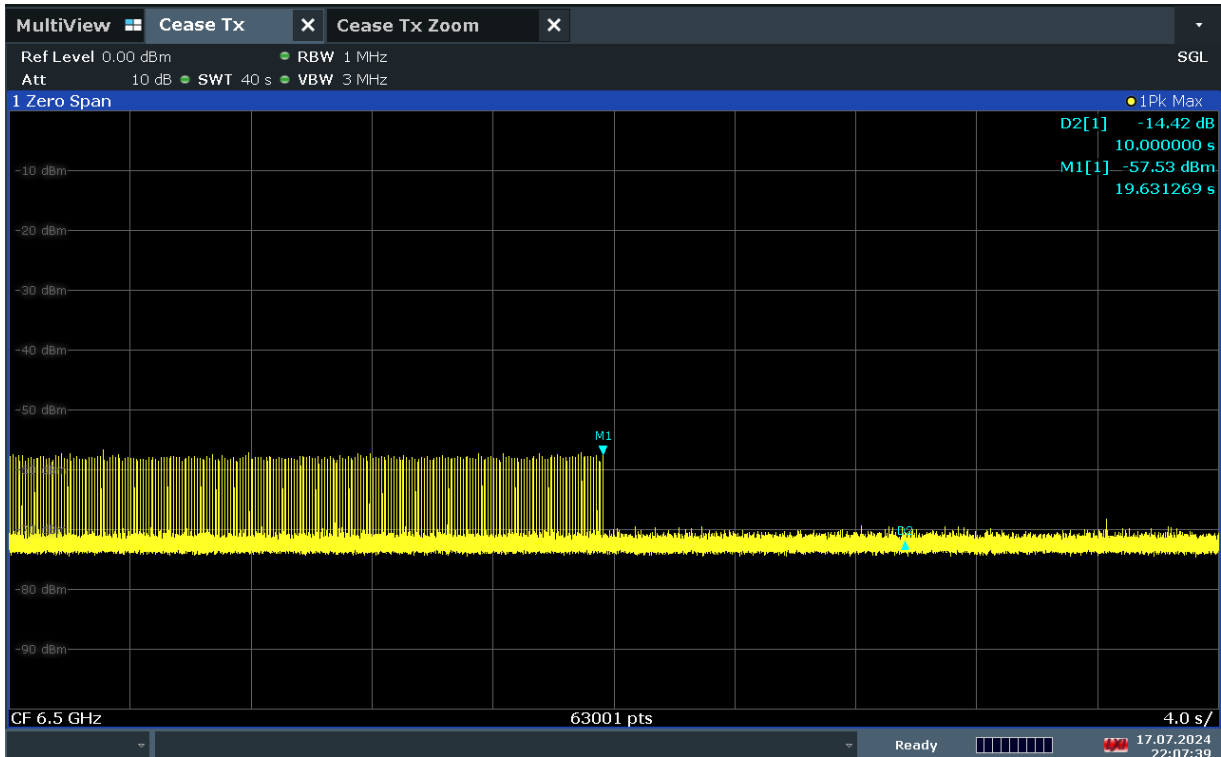

Plot 7-9. Cessation Time – Mode1 (Ch. 5, 6.5 GHz)

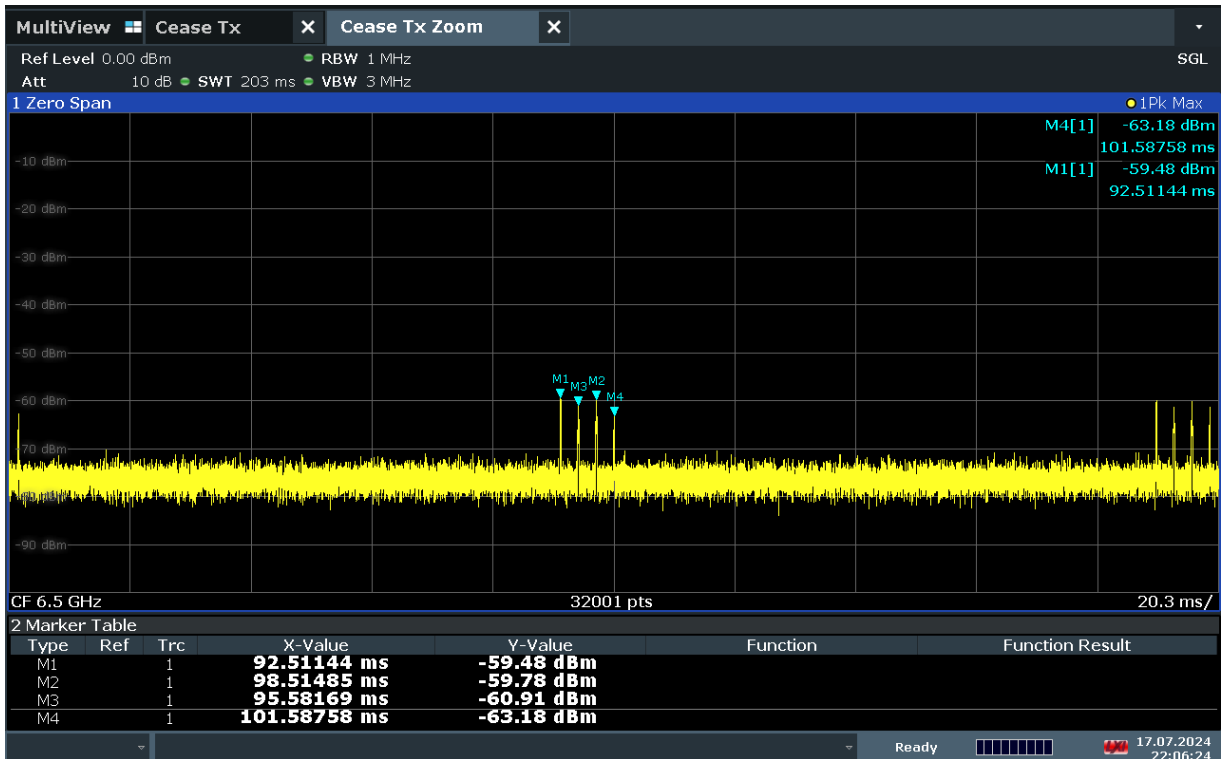

Plot 7-10. Zoom in Cessation Time – Mode1 (Ch. 5, 6.5 GHz)

FCC ID: BCG-A2999 IC: 579C-A2999		MEASUREMENT REPORT (CERTIFICATION)	Approved by: Technical Manager
Test Report S/N: 1C2405230020-11.BCG	Test Dates: 6/12/2024 - 7/19/2024	EUT Type: Watch	Page 31 of 63

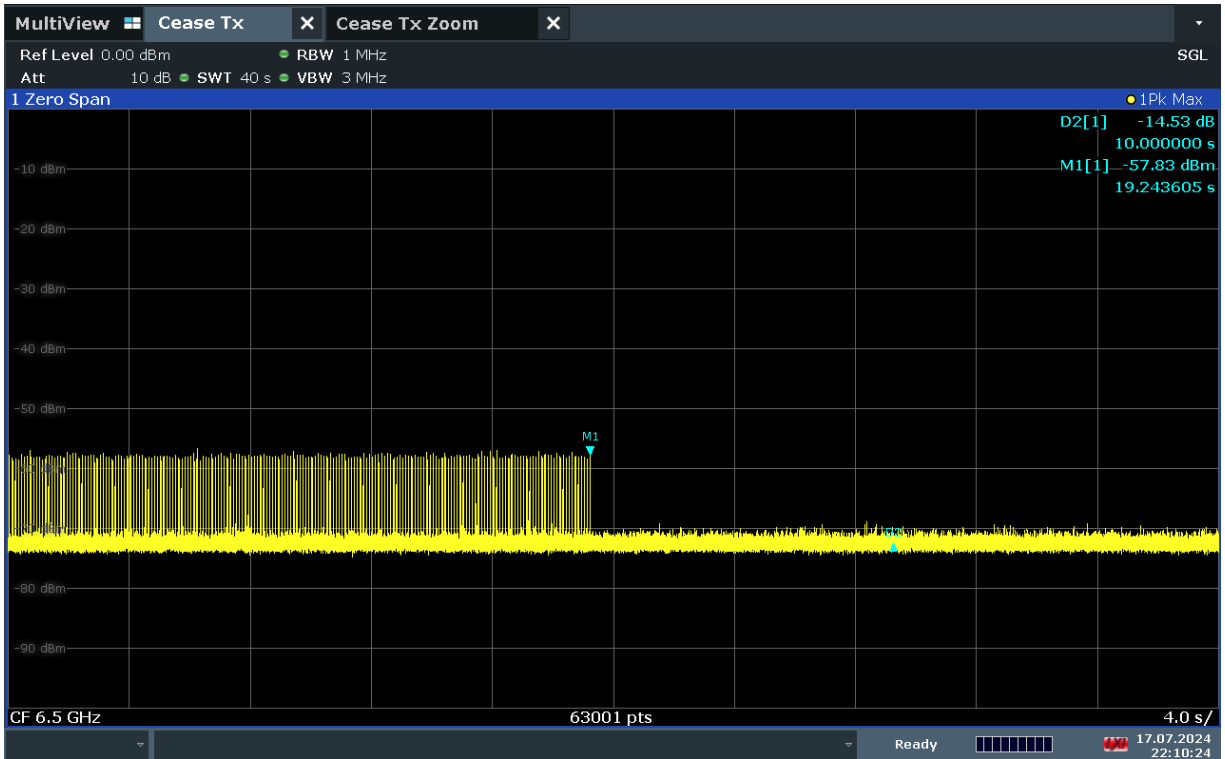

Plot 7-11. Cessation Time – Mode2 (Ch. 5, 6.5 GHz)

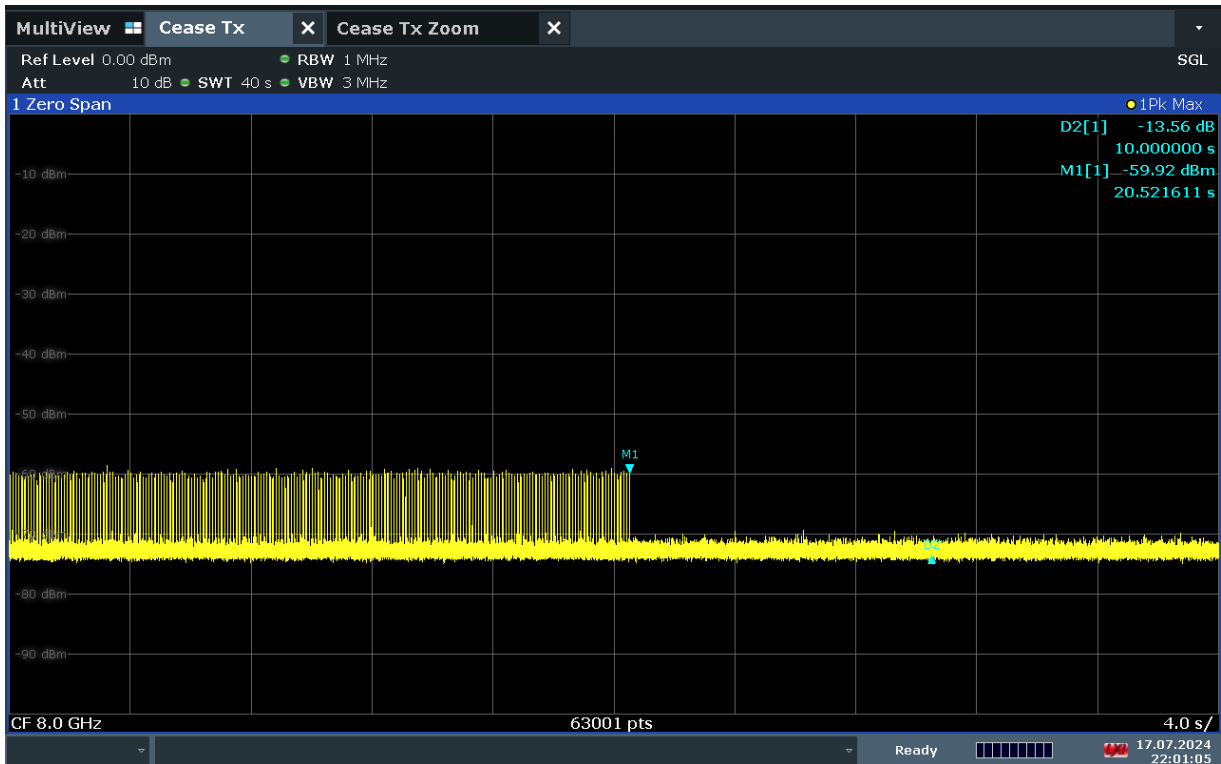

Plot 7-12. Cessation Time – Mode1 (Ch. 9, 8 GHz)

FCC ID: BCG-A2999 IC: 579C-A2999		MEASUREMENT REPORT (CERTIFICATION)	Approved by: Technical Manager
Test Report S/N: 1C2405230020-11.BCG	Test Dates: 6/12/2024 - 7/19/2024	EUT Type: Watch	Page 32 of 63

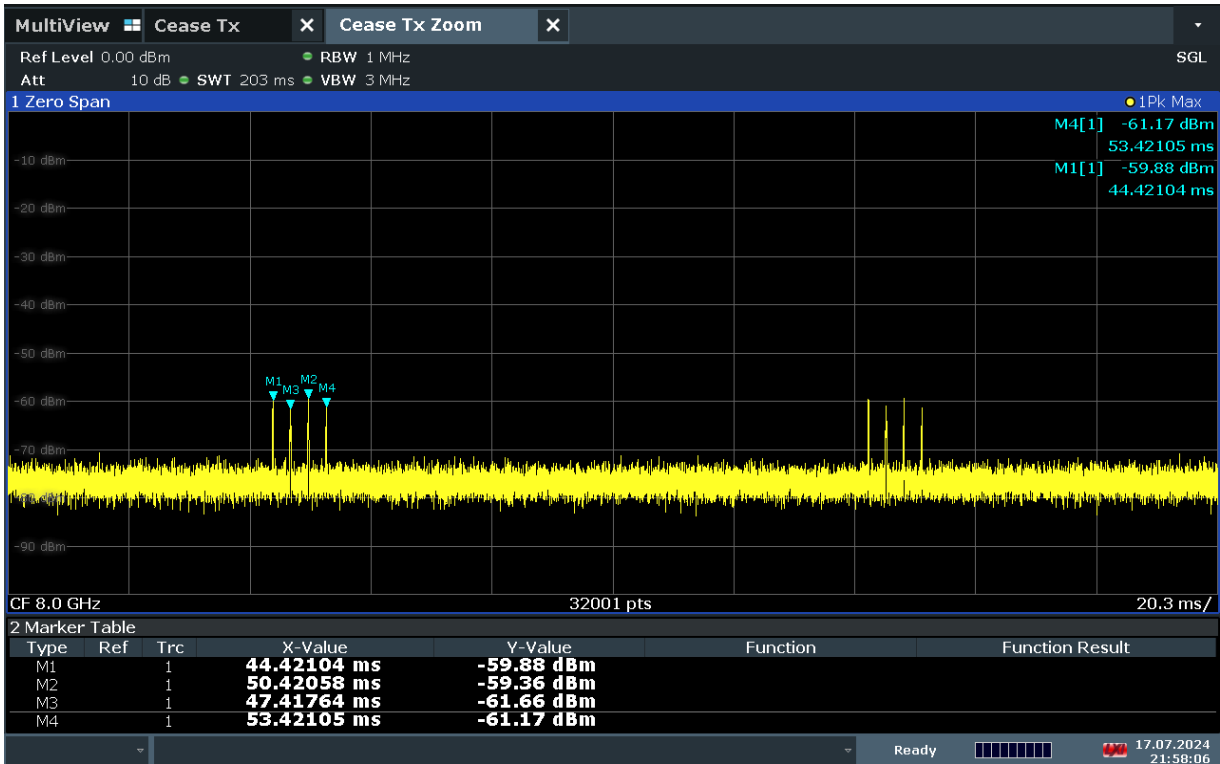

Plot 7-13. Zoom in Cessation Time – Mode1 (Ch. 9, 8 GHz)

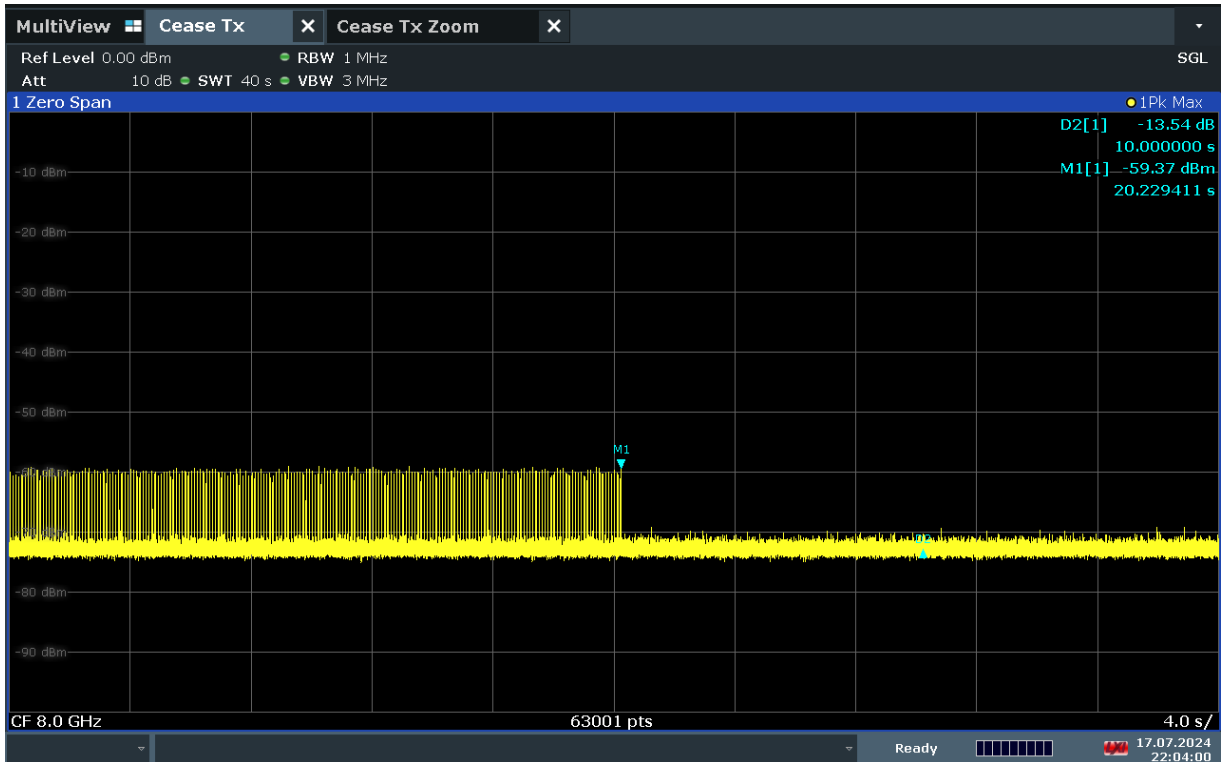

Plot 7-14. Cessation Time – Mode2 (Ch. 9, 8 GHz)

FCC ID: BCG-A2999 IC: 579C-A2999		MEASUREMENT REPORT (CERTIFICATION)	Approved by: Technical Manager
Test Report S/N: 1C2405230020-11.BCG	Test Dates: 6/12/2024 - 7/19/2024	EUT Type: Watch	Page 33 of 63



7.6 Radiated Spurious Emissions Measurements – Above 960MHz
§15.519 (c) §15.519 (d); RSS-220 [5.3.1(d)] RSS-220 [5.3.1(e)]

Test Overview and Limit

All out of band radiated spurious emissions are measured with a spectrum analyzer connected to a receive antenna while the EUT is operating at maximum power and at the appropriate frequencies. Only the radiated emissions of the configuration that produced the worst case emissions are reported in this section.

All out of band emissions must not exceed the average limits shown in Table 7-12 and Table 7-13 per Section 15.519 (C) and RSS-220[5.3.1(d)] when measured using a resolution bandwidth of 1 MHz:

Frequency [MHz]	EIRP [dBm]
960-1610	-75.3
1610-1990	-63.3
1990-3100	-61.3
3100-10600	-41.3
Above 10600	-61.3

Table 7-12. FCC 15.519 Radiated Spurious Emissions Limits

Frequency [MHz]	EIRP [dBm]
960-1610	-75.3
1610-4750	-70.0
4750-10600	-41.3
Above 10600	-61.3

Table 7-13. RSS-220 Radiated Spurious Emissions Limits

All out of band emissions must not exceed the average limits shown in Table 7-14 per Section 15.519 (d) and RSS-220(5.3.1)(e) when measured using a resolution bandwidth greater than or equal to 1 kHz. The measurements shall demonstrate compliance with the stated limits at whatever resolution bandwidth is used.

Frequency [MHz]	EIRP [dBm]
1164-1240	-85.3
1559-1610	-85.3

Table 7-14. FCC 15.519/RSS-220 Radiated Spurious Emissions Limits for GPS frequency bands

Test Procedures Used

ANSI C63.10-2020 – Section 10.3
 KDB 393764 D01 v02r01

FCC ID: BCG-A2999 IC: 579C-A2999		MEASUREMENT REPORT (CERTIFICATION)	Approved by: Technical Manager
Test Report S/N: 1C2405230020-11.BCG	Test Dates: 6/12/2024 - 7/19/2024	EUT Type: Watch	Page 34 of 63

V 10.5 12/15/2021

Test Settings

Average RSE Measurements

1. RBW = 1MHz (30kHz for emissions in the GPS band)
2. VBW = 3MHz (100kHz for emissions in the GPS band)
3. Detector = Average (RMS)
4. Sweep time = No more than a 1 ms integration period over each measurement bin
5. Trace mode = Max hold
6. Trace was allowed to stabilize

Test Setup

The EUT and measurement equipment were set up as shown in the diagram below.

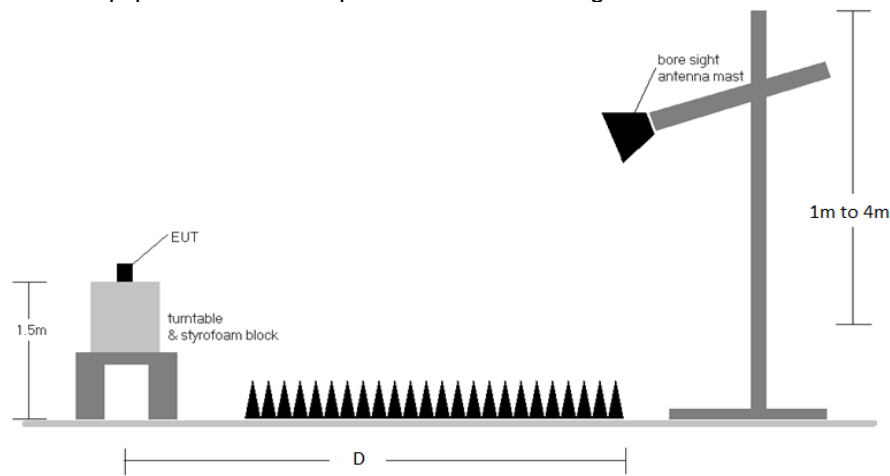

Figure 7-5. Radiated Test Setup - Above 960MHz

Test Notes

1. All modes of operation were investigated and the worst-case emissions are reported.
2. This unit was tested with its standard battery.
3. The RBW for measurements in the GPS Bands were reduced to 30kHz in order to show compliance.
4. D is the measurement test distance and emissions from 960MHz - 18GHz were measured at 0.6 meter test distance while emissions above 18GHz were measured at 0.5 meter test distance with the application of a distance correction factor.
5. The "-" shown in the following RSE tables are used to denote a noise floor measurement.
6. 6GHz - 9GHz RSE is covered in EIRP section (Section 7.4).

FCC ID: BCG-A2999 IC: 579C-A2999	 MEASUREMENT REPORT (CERTIFICATION)	Approved by: Technical Manager
Test Report S/N: 1C2405230020-11.BCG		Test Dates: 6/12/2024 - 7/19/2024

Sample Calculations

Determining Spurious Emissions Levels

- $E_{[dB\mu V/m]} = \text{Analyzer level}_{[dBm]} + 107 + \text{AFCL}_{[dB/m]}$
- $\text{Spurious Emission Level}_{[dBm]} = E_{[dB\mu V/m]} + 20 \log(D_{\text{Meas}}) - 104.8$
- $\text{Spurious Emission Level}_{[dBm]} = \text{Analyzer Level}_{[dBm]} + \text{AFCL}_{[dB/m]} + \text{Conversion Factor}_{[dB]}$
- $\text{AFCL}_{[dB/m]} = (\text{Antenna Factor}_{[dB/m]} + \text{Cable Loss}_{[dB]} + \text{Attenuator}_{[dB]}) - \text{Preamplifier Gain}_{[dB]}$
- $\text{Conversion Factor}_{[dB]} = 107 - 104.8 + 20 \log(D_{\text{Meas}})$
- $\text{Margin}_{[dB]} = \text{Spurious Emission Level}_{[dBm]} - \text{Limit}_{[dBm]}$

FCC ID: BCG-A2999 IC: 579C-A2999	 MEASUREMENT REPORT (CERTIFICATION)		Approved by: Technical Manager
Test Report S/N: 1C2405230020-11.BCG	Test Dates: 6/12/2024 - 7/19/2024	EUT Type: Watch	Page 36 of 63

Radiated Spurious Emission Measurements (960MHz – 18GHz)

§15.519(c); RSS-220 [5.3.1(d)]

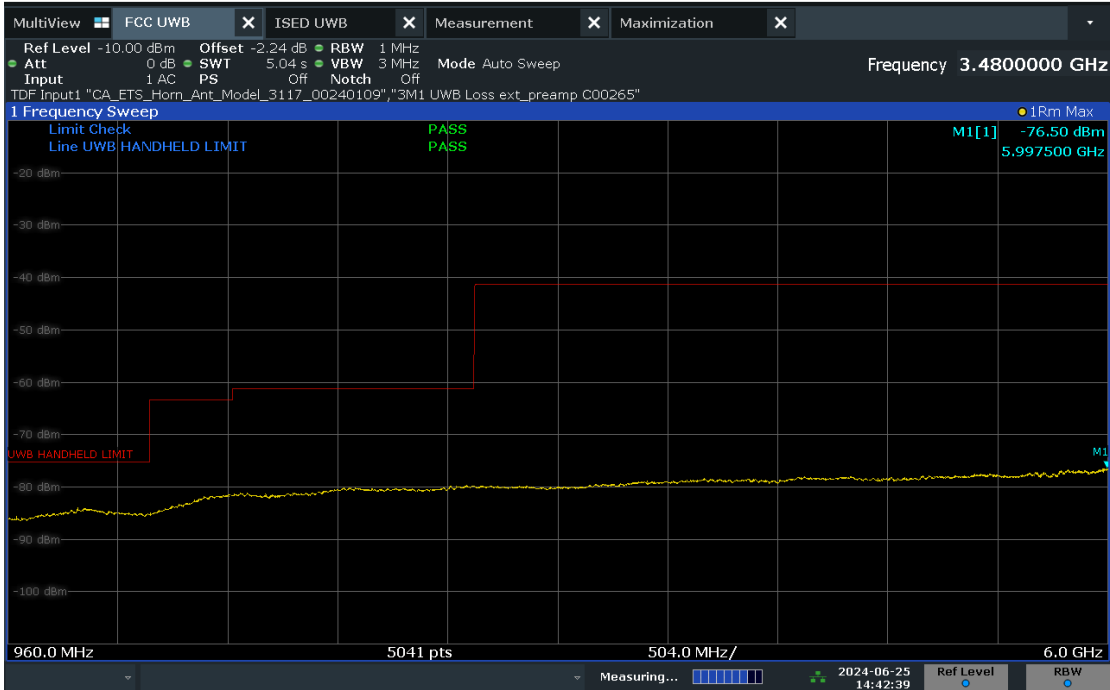

Plot 7-15. FCC Radiated Spurious Emission 960-6000MHz (Ch. 5, Config 409, Payload 4093 Ant. Pol. H)

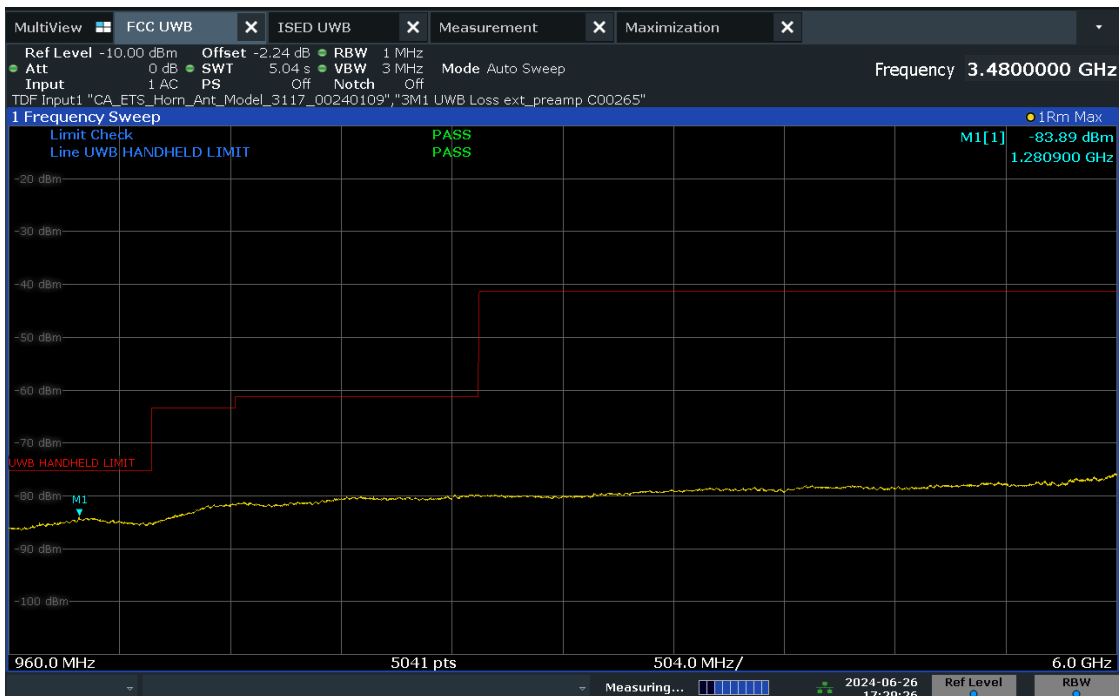

Plot 7-16. FCC Radiated Spurious Emissions 960-6000MHz (Ch. 5, Config 409, Payload 4093 Ant. Pol. V)

FCC ID: BCG-A2999 IC: 579C-A2999		MEASUREMENT REPORT (CERTIFICATION)	Approved by: Technical Manager
Test Report S/N: 1C2405230020-11.BCG	Test Dates: 6/12/2024 - 7/19/2024	EUT Type: Watch	Page 37 of 63

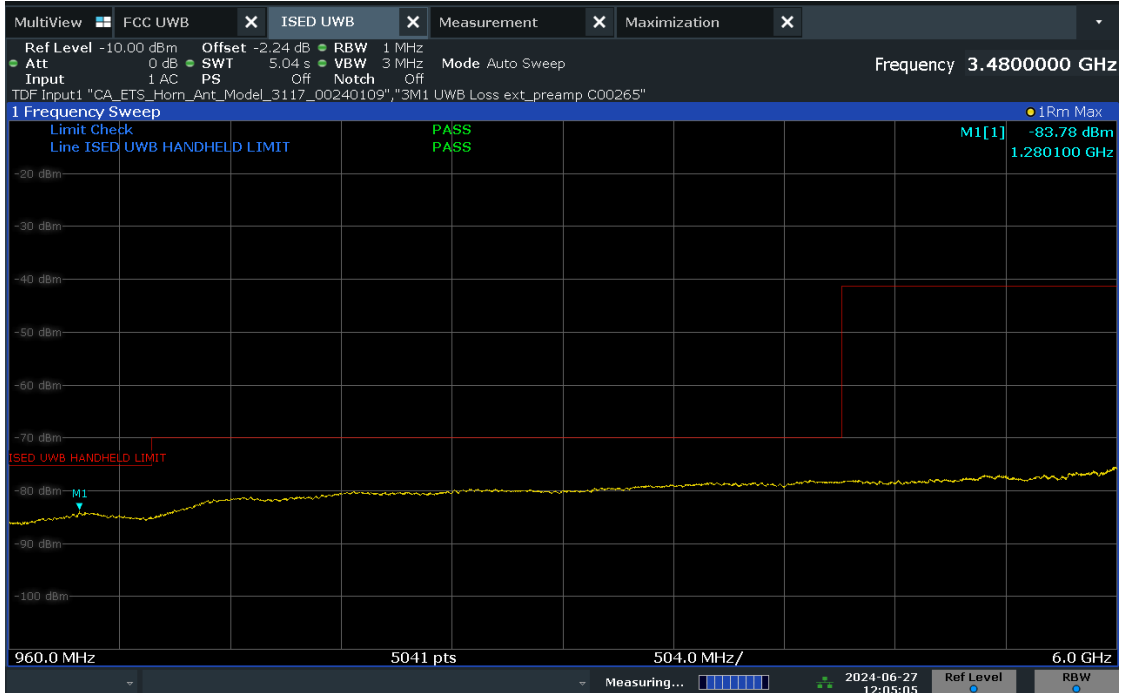

Plot 7-17. ISED Radiated Spurious Emission 960-6000MHz (Ch. 5, Config 409, Payload 4093 Ant. Pol. H)

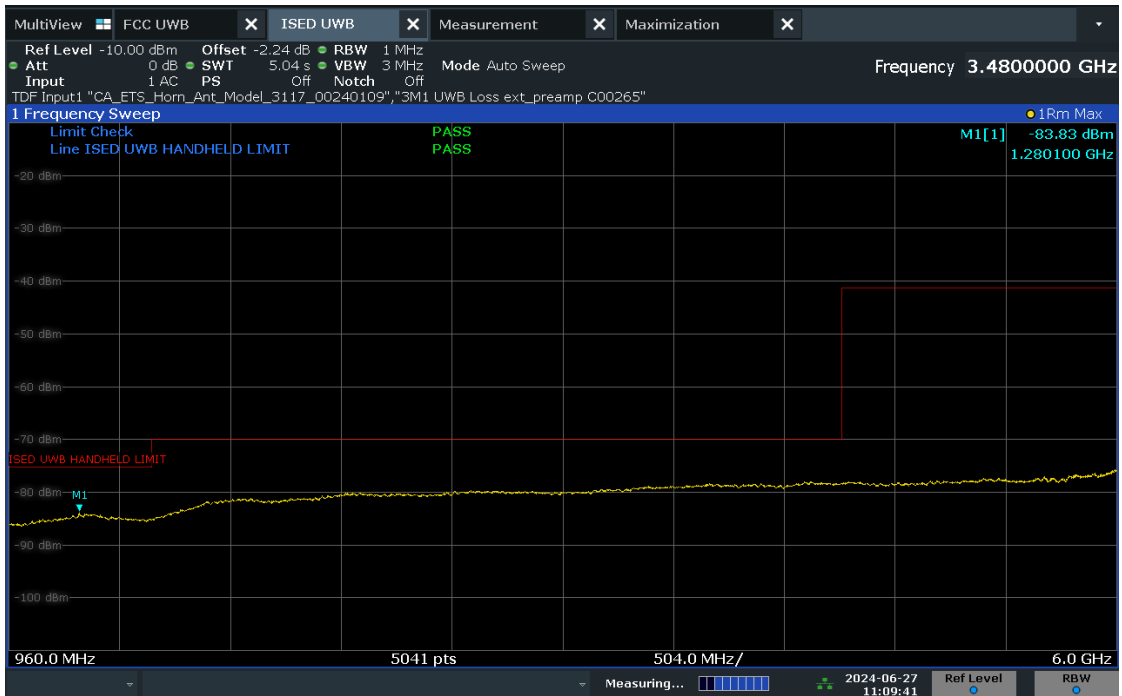

Plot 7-18. ISED Radiated Spurious Emission 960-6000MHz (Ch. 5, Config 409, Payload 4093 Ant. Pol. V)

FCC ID: BCG-A2999 IC: 579C-A2999		MEASUREMENT REPORT (CERTIFICATION)	Approved by: Technical Manager
Test Report S/N: 1C2405230020-11.BCG	Test Dates: 6/12/2024 - 7/19/2024	EUT Type: Watch	Page 38 of 63

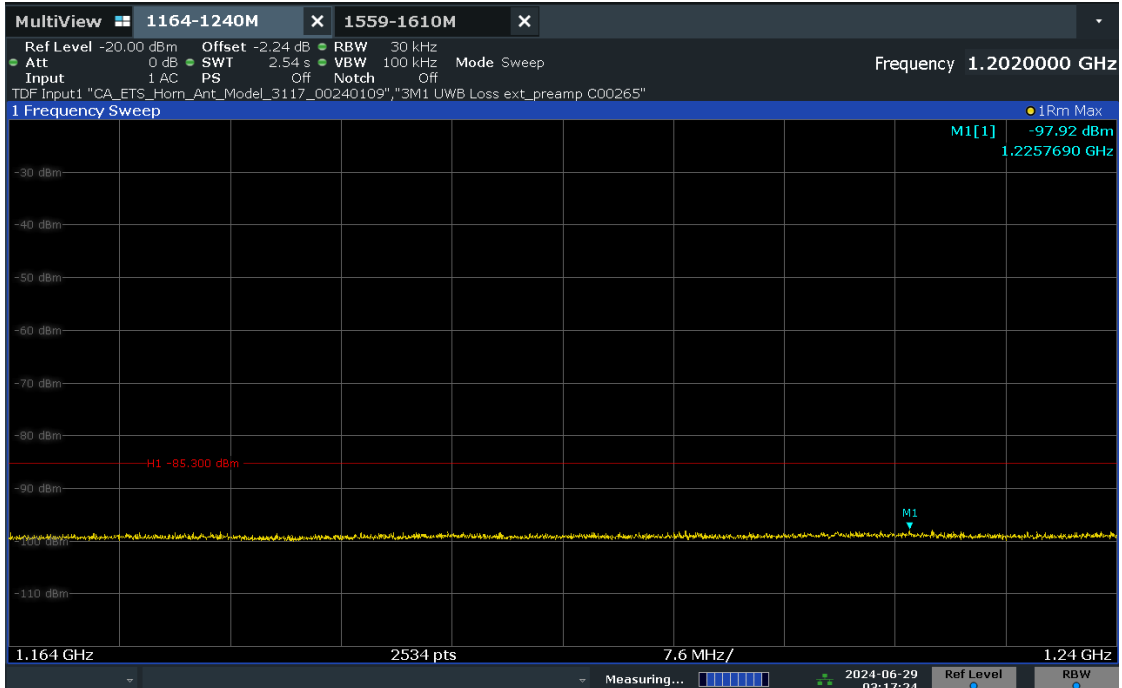

Plot 7-19. Radiated Spurious Emission 1164-1240MHz (Ch. 5, Config 409, Payload 4093 Ant. Pol. H)

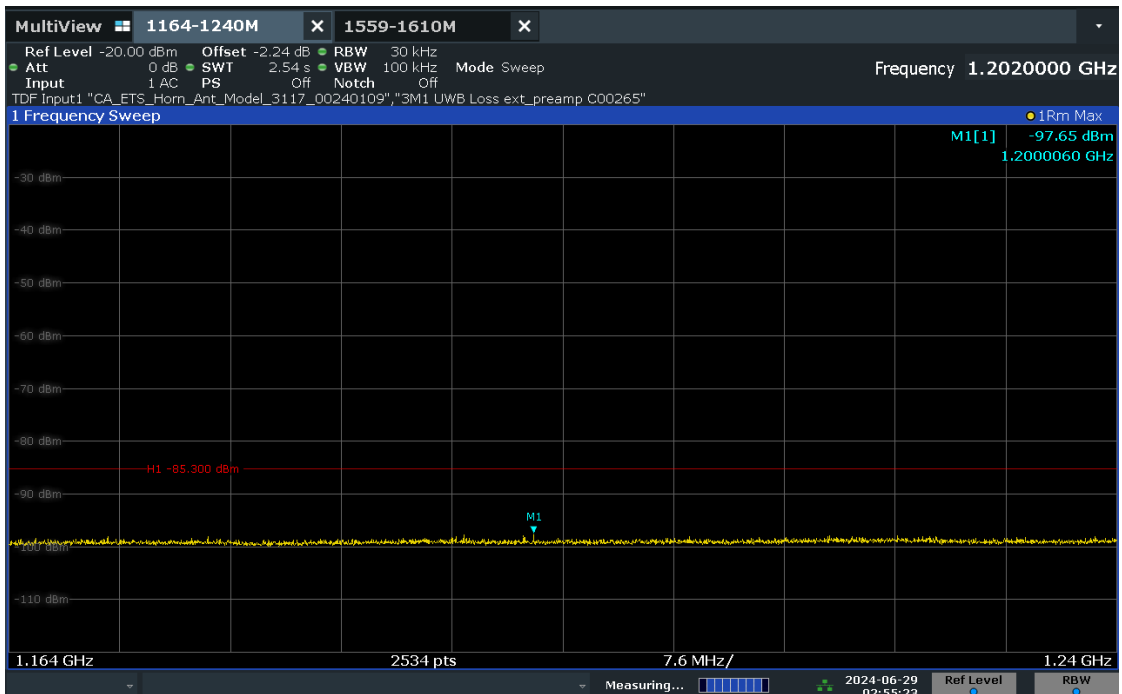

Plot 7-20. Radiated Spurious Emission 1164-1240MHz (Ch. 5, Config 409, Payload 4093 Ant. Pol. V)

FCC ID: BCG-A2999 IC: 579C-A2999		MEASUREMENT REPORT (CERTIFICATION)	Approved by: Technical Manager
Test Report S/N: 1C2405230020-11.BCG			Test Dates: 6/12/2024 - 7/19/2024

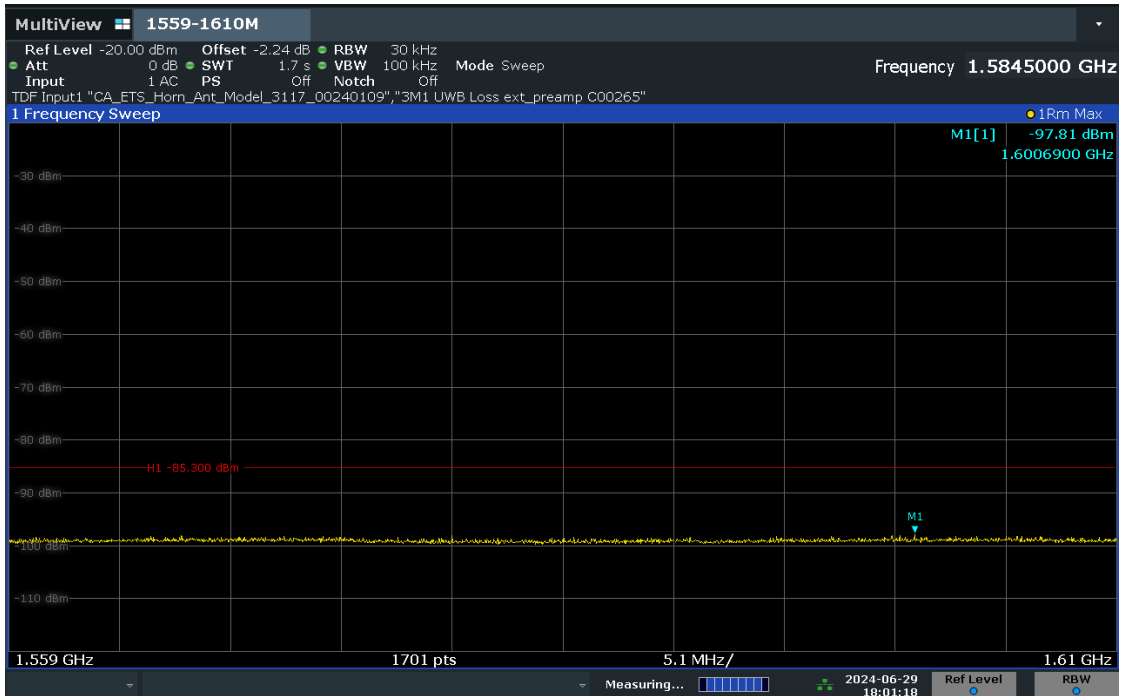

Plot 7-21. Radiated Spurious Emission 1559-1610MHz (Ch. 5, Config 409, Payload 4093 Ant. Pol. H)

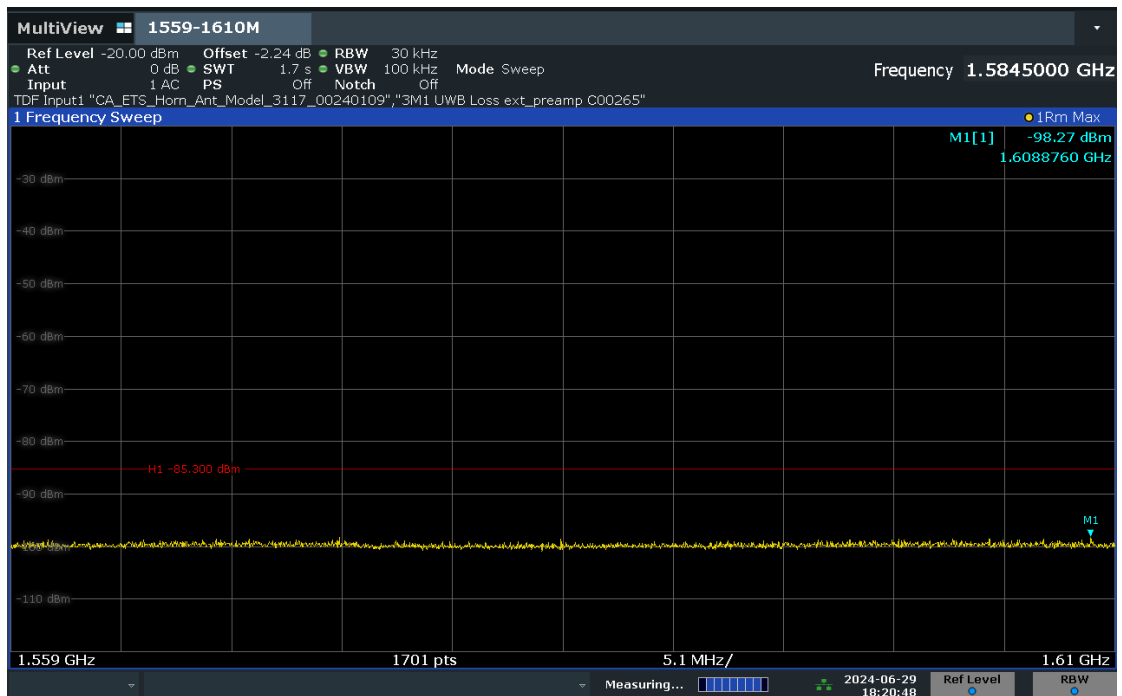

Plot 7-22. Radiated Spurious Emission 1559-1610MHz (Ch. 5, Config 409, Payload 4093 Ant. Pol. V)

FCC ID: BCG-A2999 IC: 579C-A2999	 MEASUREMENT REPORT (CERTIFICATION)		Approved by: Technical Manager
Test Report S/N: 1C2405230020-11.BCG	Test Dates: 6/12/2024 - 7/19/2024	EUT Type: Watch	Page 40 of 63

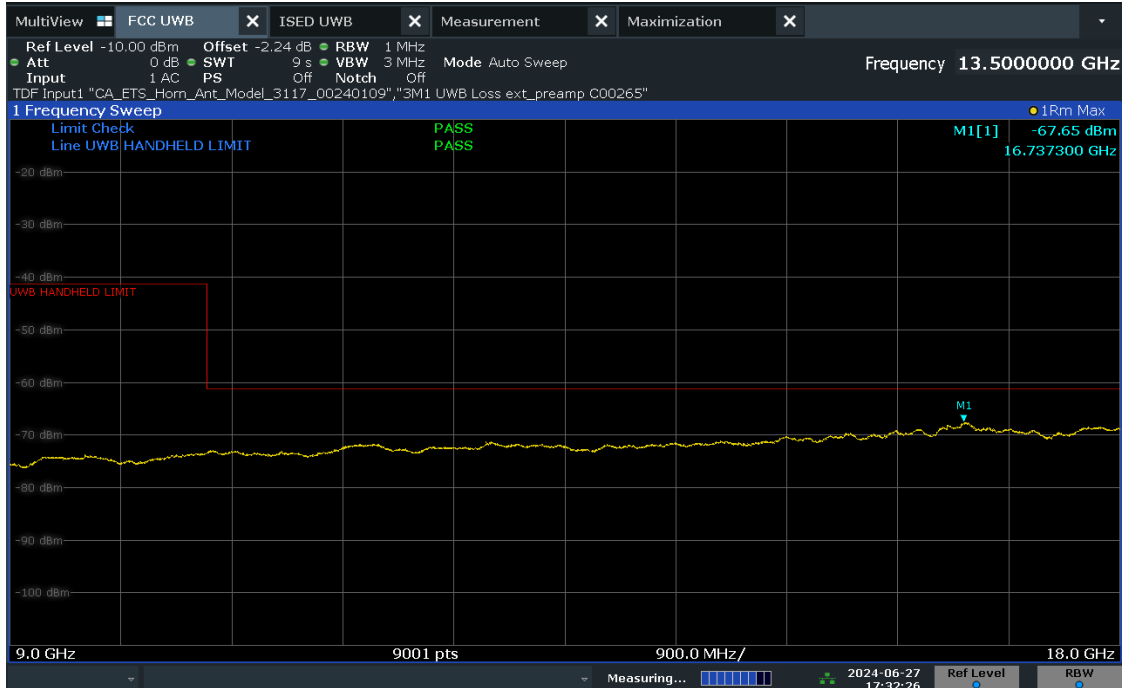

Plot 7-23. Radiated Spurious Emission 9-18GHz (Ch. 5, Config 409, Payload 4093 Ant. Pol. H)

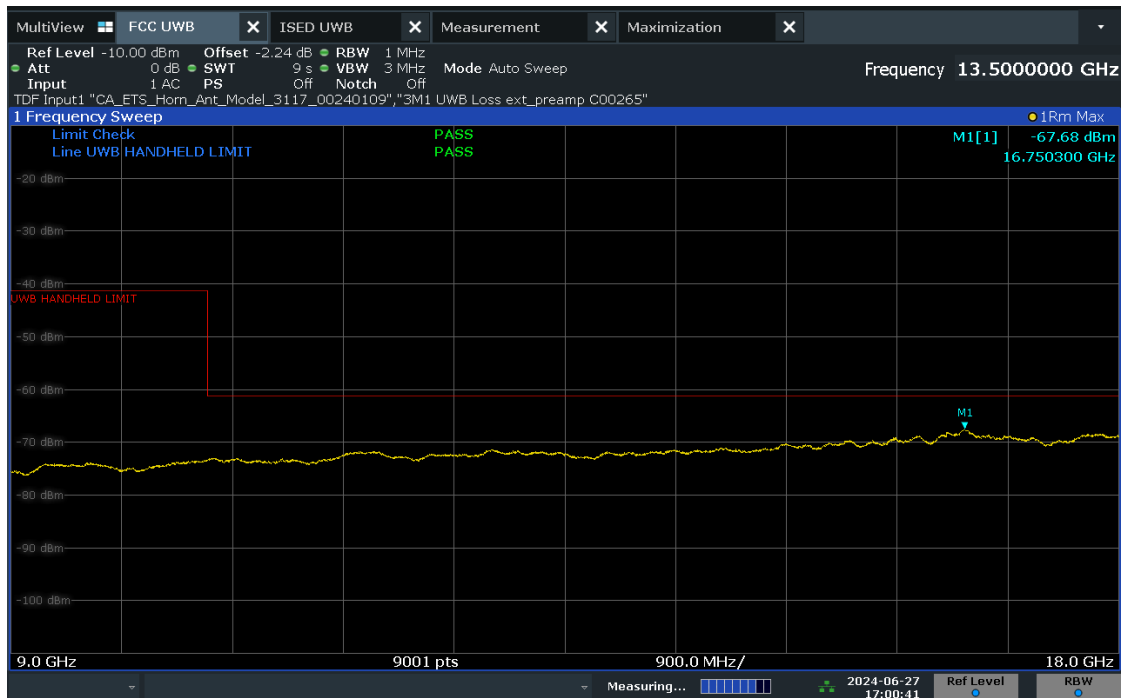

Plot 7-24. Radiated Spurious Emission 9-18GHz (Ch. 5, Config 409, Payload 4093 Ant. Pol. H)

FCC ID: BCG-A2999 IC: 579C-A2999	 MEASUREMENT REPORT (CERTIFICATION)	Approved by: Technical Manager
Test Report S/N: 1C2405230020-11.BCG		Test Dates: 6/12/2024 - 7/19/2024

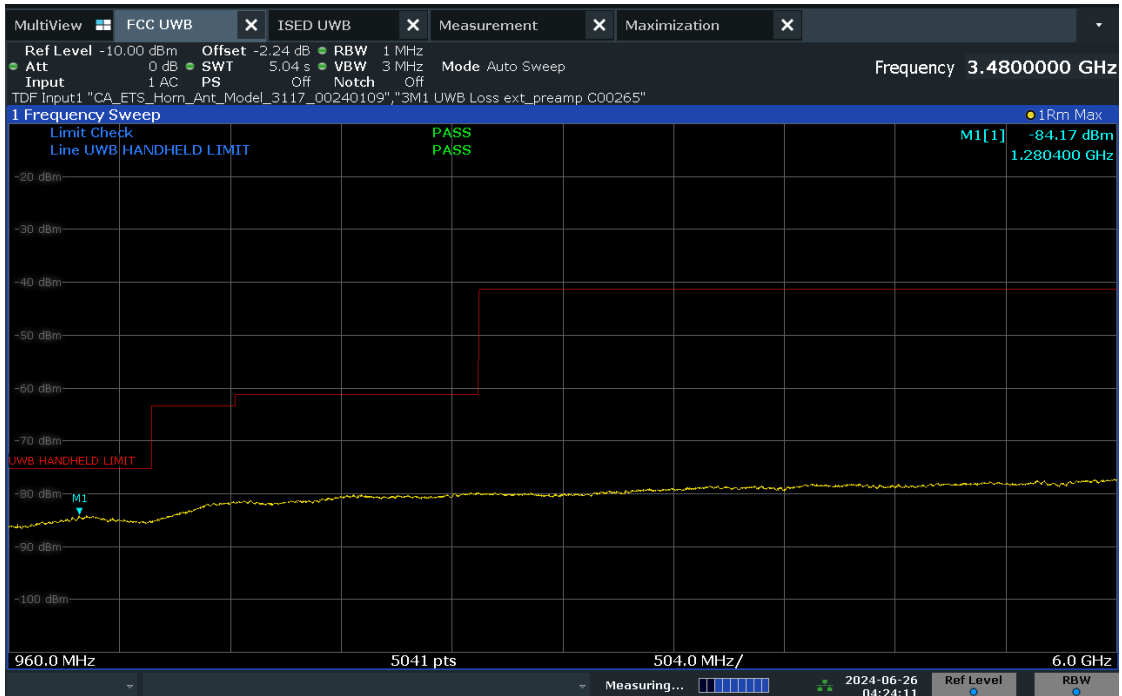

Plot 7-25. FCC Radiated Spurious Emission 960-6000MHz (Ch. 9, Config 409, Payload 4093 Ant. Pol. H)

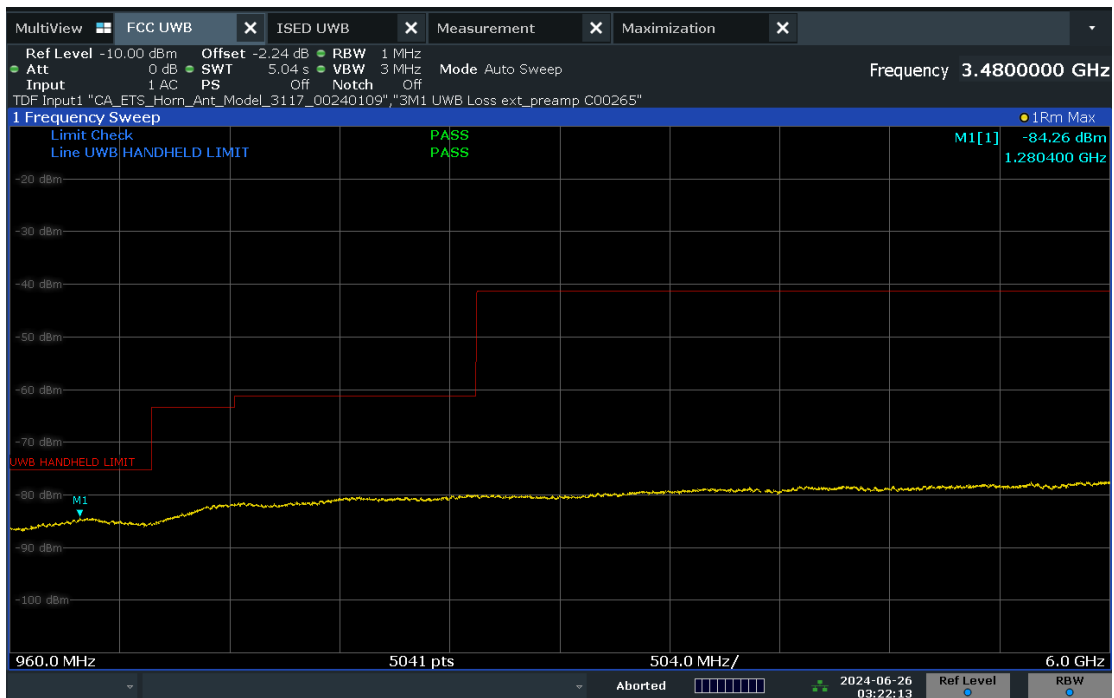

Plot 7-26. FCC Radiated Spurious Emission 960-6000MHz (Ch.9, Config 409, Payload 4093 Ant. Pol. V)

FCC ID: BCG-A2999 IC: 579C-A2999		MEASUREMENT REPORT (CERTIFICATION)	Approved by: Technical Manager
Test Report S/N: 1C2405230020-11.BCG	Test Dates: 6/12/2024 - 7/19/2024	EUT Type: Watch	Page 42 of 63

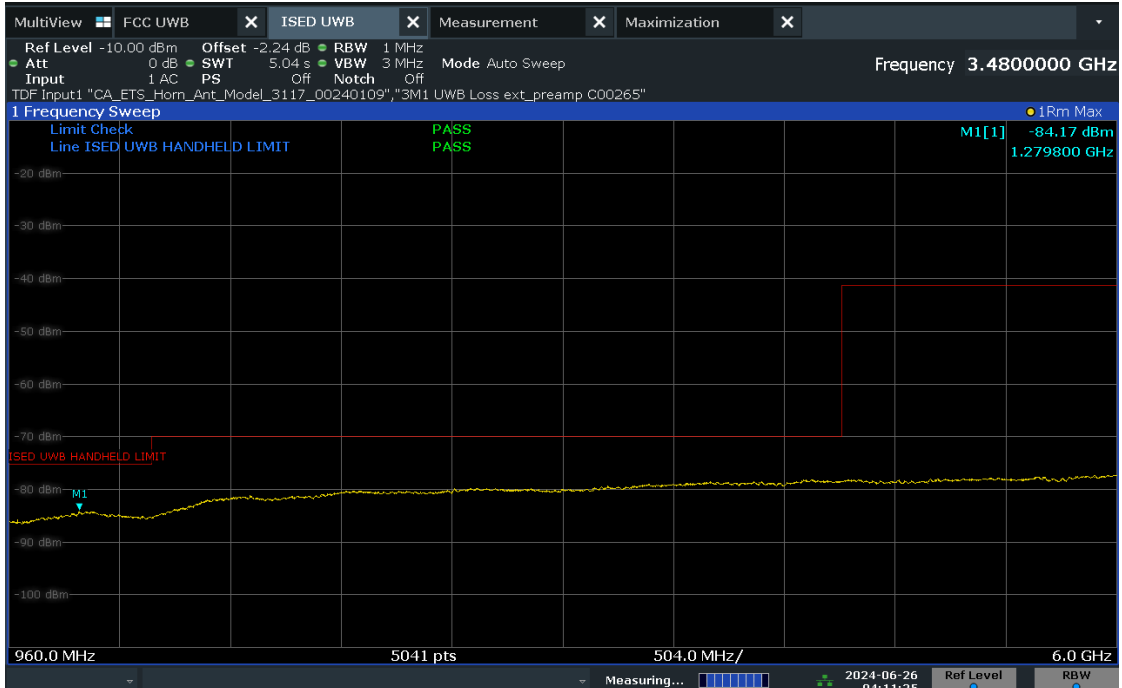

Plot 7-27. ISED Radiated Spurious Emission 960-6000MHz (Ch. 9, Config 409, Payload 4093 Ant. Pol. H)

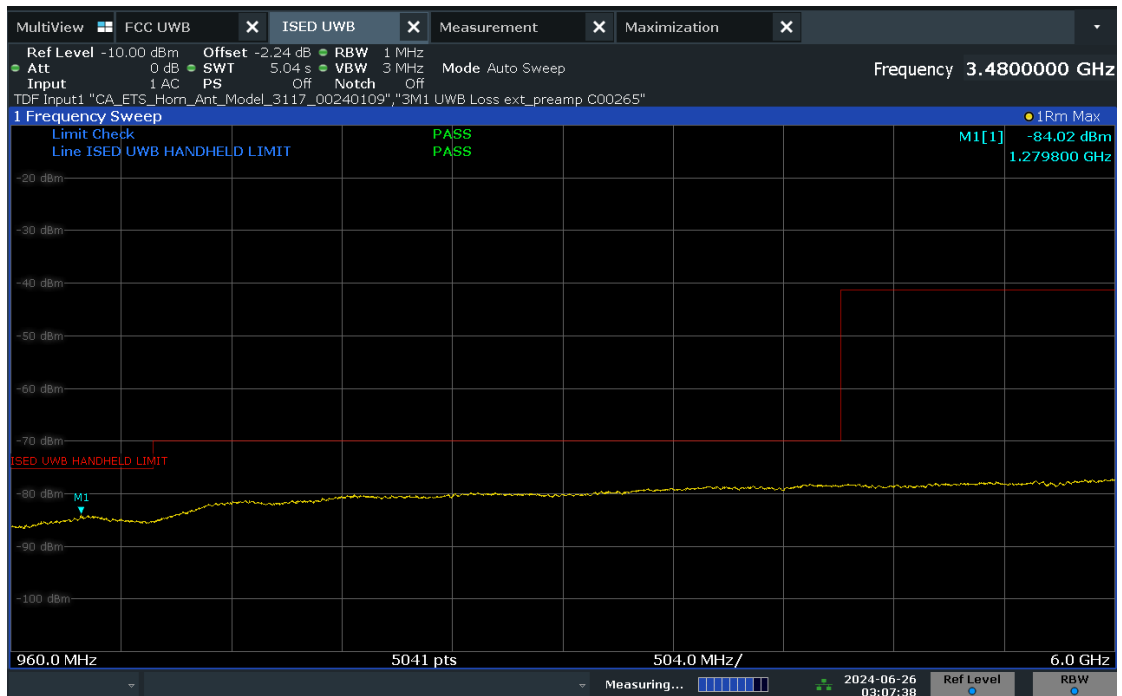

Plot 7-28. ISED Radiated Spurious Emission 960-6000MHz (Ch.9, Config 409, Payload 4093 Ant. Pol. V)

FCC ID: BCG-A2999 IC: 579C-A2999		MEASUREMENT REPORT (CERTIFICATION)	Approved by: Technical Manager
Test Report S/N: 1C2405230020-11.BCG			Test Dates: 6/12/2024 - 7/19/2024

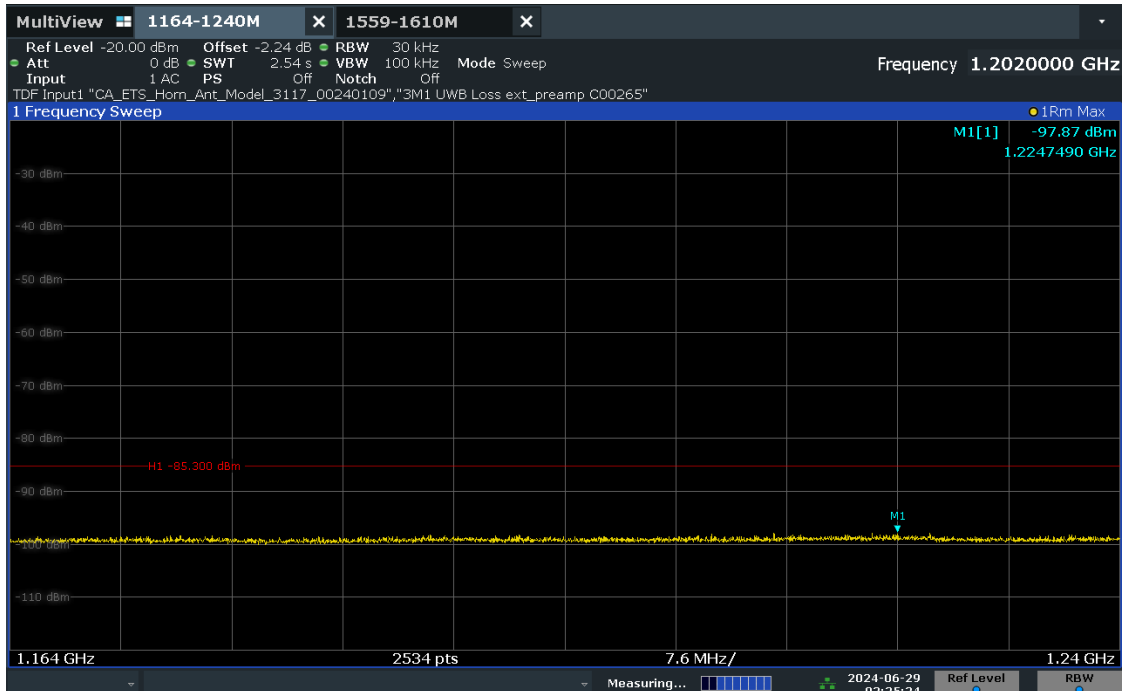

Plot 7-29. Radiated Spurious Emission 1164-1240MHz (Ch. 9, Config 409, Payload 4093 Ant. Pol. H)

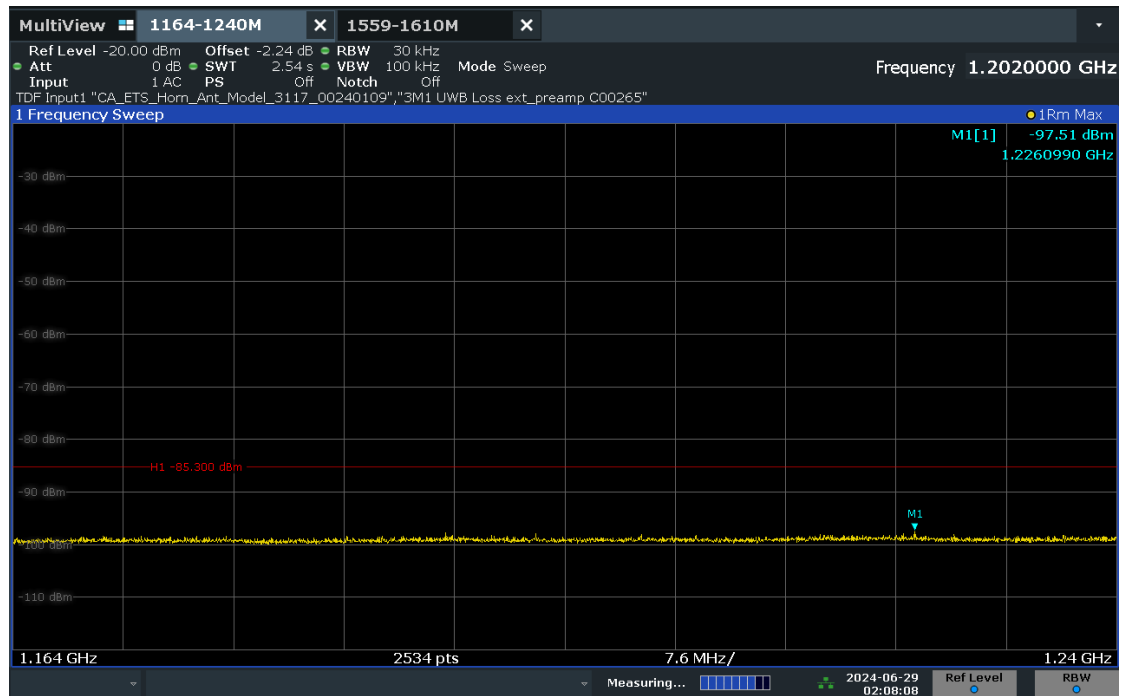

Plot 7-30. Radiated Spurious Emission 1164-1240MHz (Ch. 9, Config 409, Payload 4093 Ant. Pol. V)

FCC ID: BCG-A2999 IC: 579C-A2999		MEASUREMENT REPORT (CERTIFICATION)	Approved by: Technical Manager
Test Report S/N: 1C2405230020-11.BCG	Test Dates: 6/12/2024 - 7/19/2024	EUT Type: Watch	Page 44 of 63

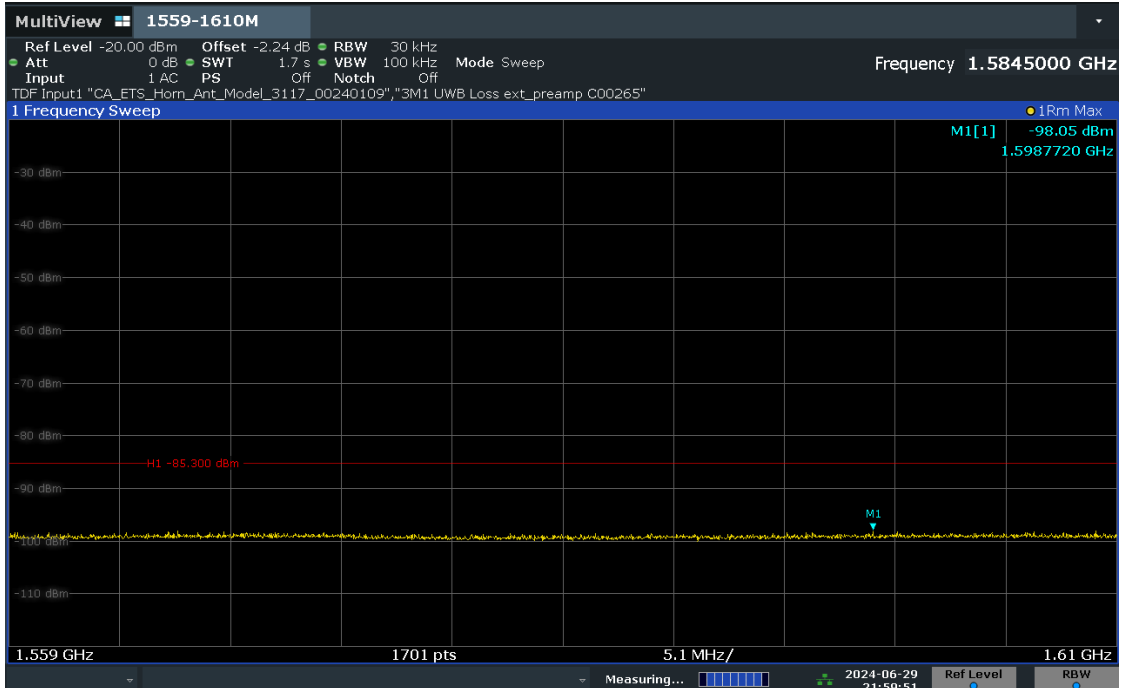

Plot 7-31. Radiated Spurious Emission 1559-1610MHz (Ch. 9, Config 409, Payload 4093 Ant. Pol. H)

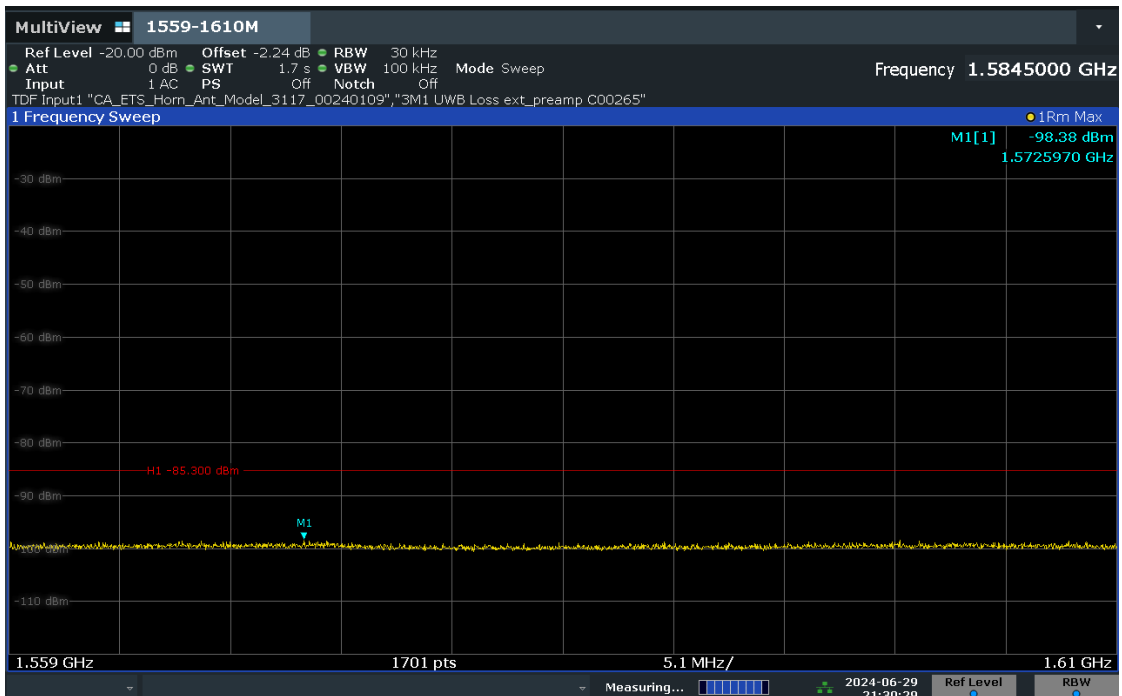

Plot 7-32. Radiated Spurious Emission 1559-1610MHz (Ch. 9, Config 409, Payload 4093 Ant. Pol. V)

FCC ID: BCG-A2999 IC: 579C-A2999		MEASUREMENT REPORT (CERTIFICATION)	Approved by: Technical Manager
Test Report S/N: 1C2405230020-11.BCG	Test Dates: 6/12/2024 - 7/19/2024	EUT Type: Watch	Page 45 of 63

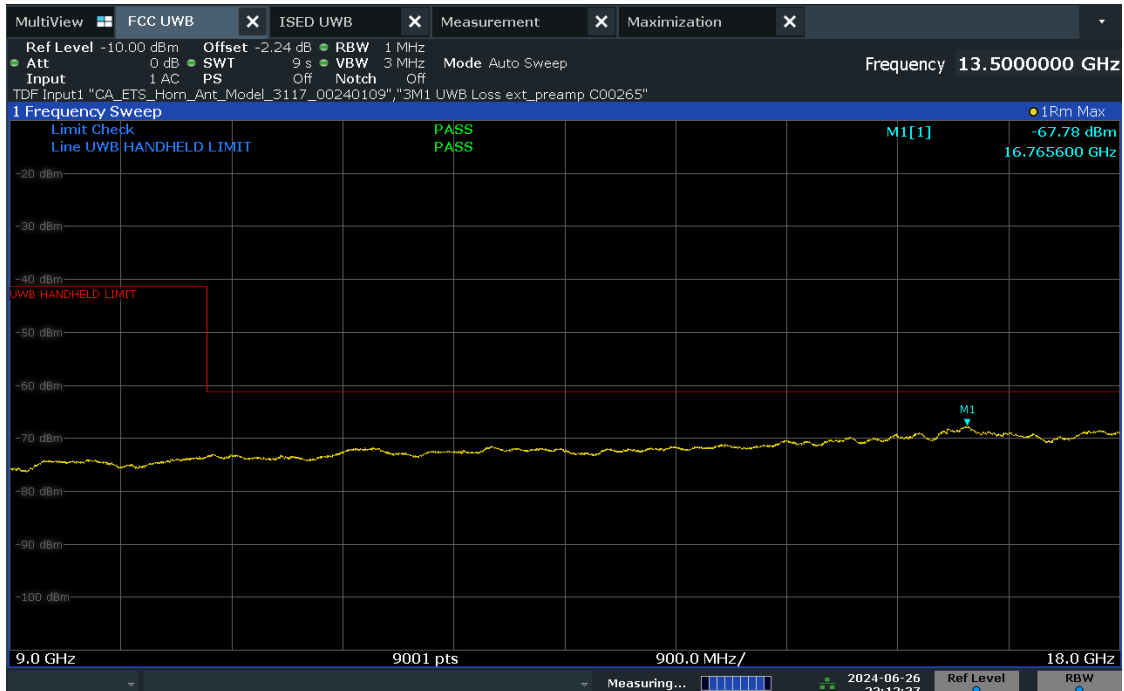

Plot 7-33. Radiated Spurious Emission 9-18GHz (Ch. 9, Config 409, Payload 4093 Ant. Pol. H)

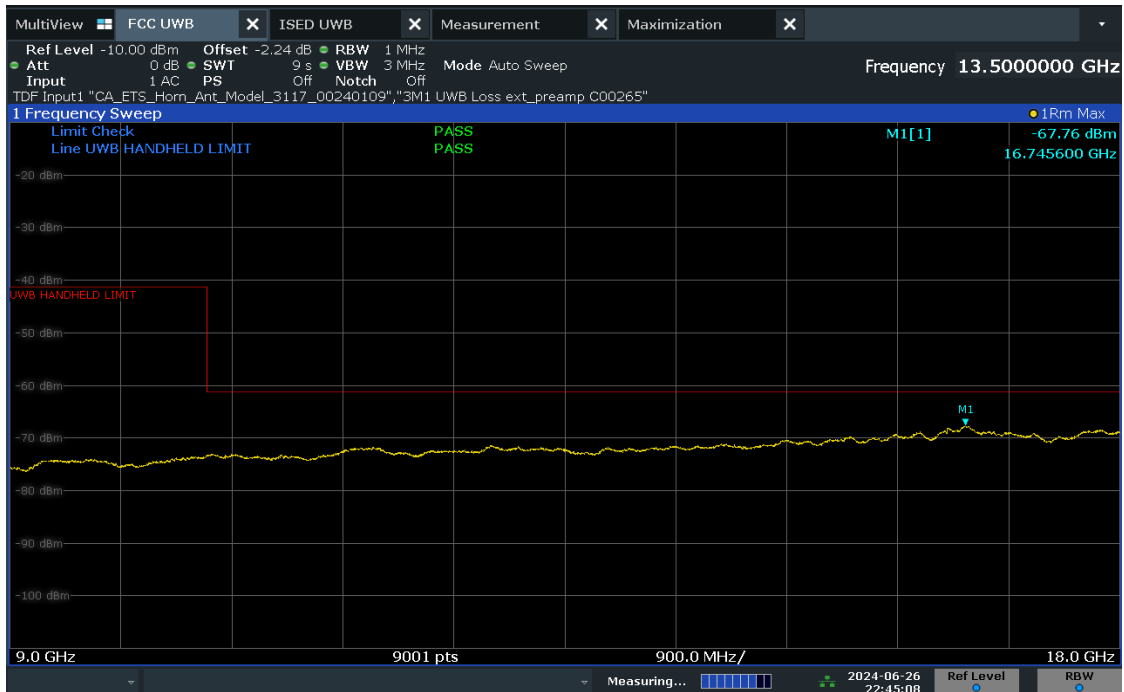

Plot 7-34. Radiated Spurious Emission 9-18GHz (Ch. 9, Config 409, Payload 4093 Ant. Pol. V)

FCC ID: BCG-A2999 IC: 579C-A2999		MEASUREMENT REPORT (CERTIFICATION)	Approved by: Technical Manager
Test Report S/N: 1C2405230020-11.BCG			Test Dates: 6/12/2024 - 7/19/2024

Radiated Spurious Emissions (Above 18GHz) §15.519 (c); RSS-220 [5.3.1(d)]

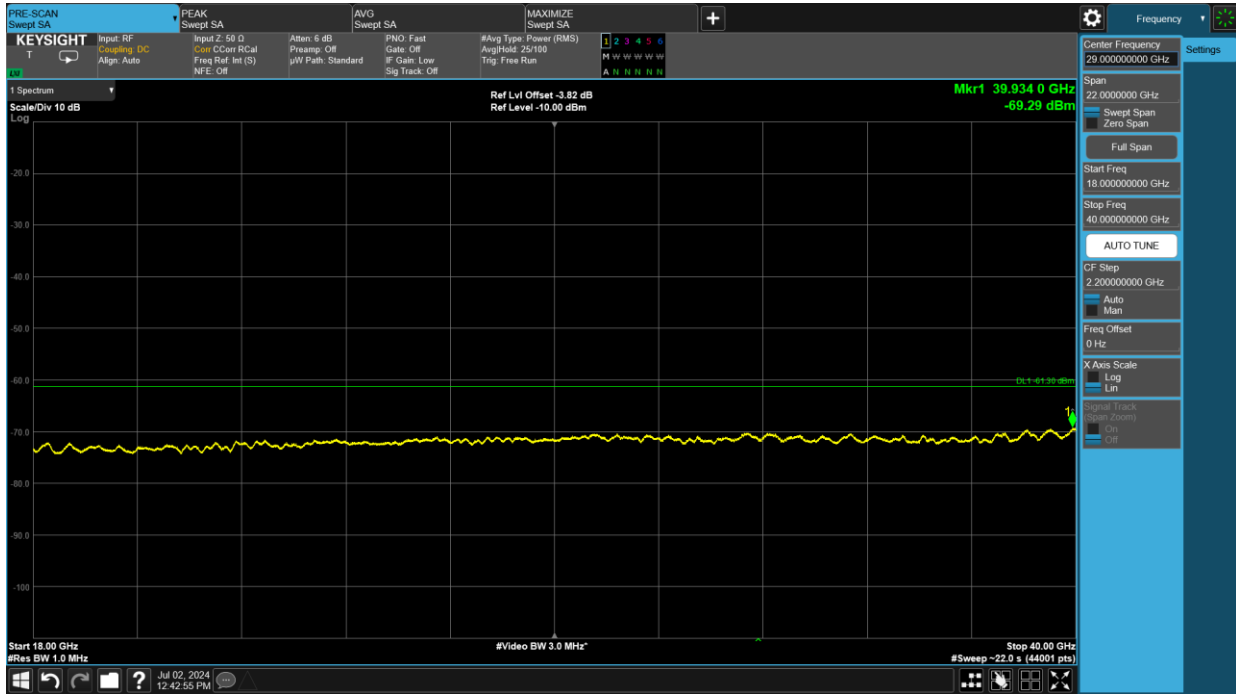

Plot 7-35. Radiated Spurious Emission 18-40GHz (Ch. 5, Config 409, Payload 4093 Ant. Pol. H)

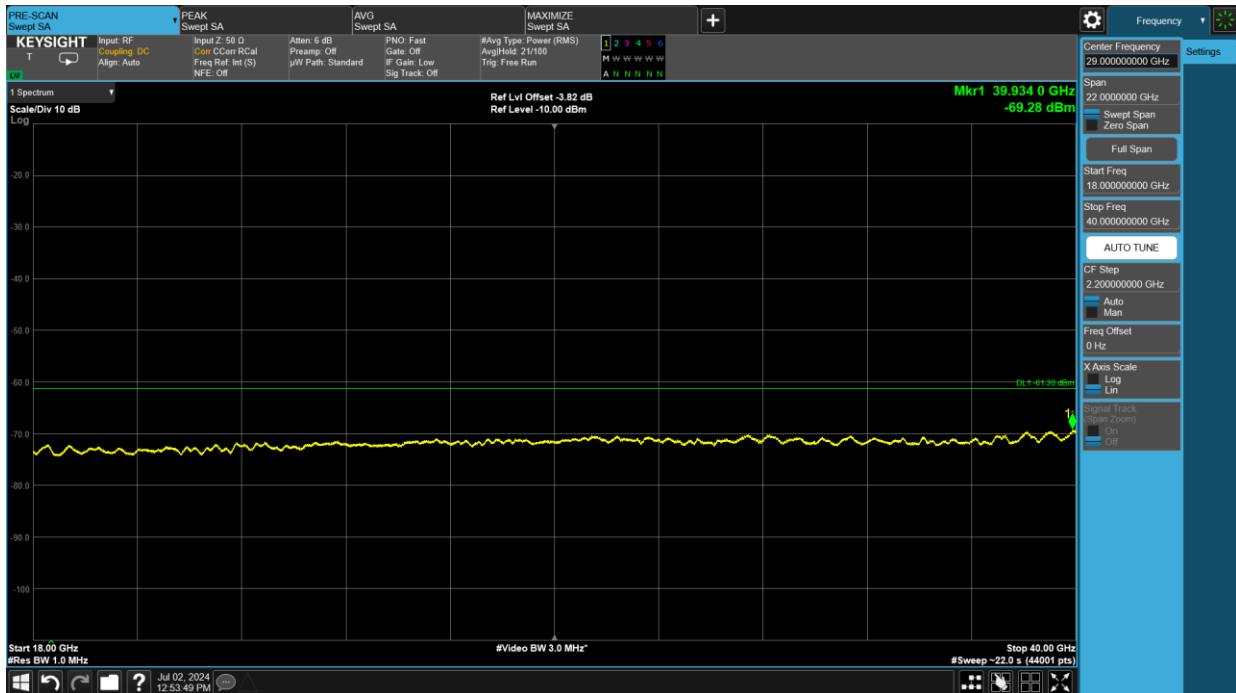

Plot 7-36. Radiated Spurious Emission 18-40GHz (Ch. 5, Config 409, Payload 4093 Ant. Pol. V)

FCC ID: BCG-A2999 IC: 579C-A2999		MEASUREMENT REPORT (CERTIFICATION)	Approved by: Technical Manager
Test Report S/N: 1C2405230020-11.BCG	Test Dates: 6/12/2024 - 7/19/2024	EUT Type: Watch	Page 47 of 63

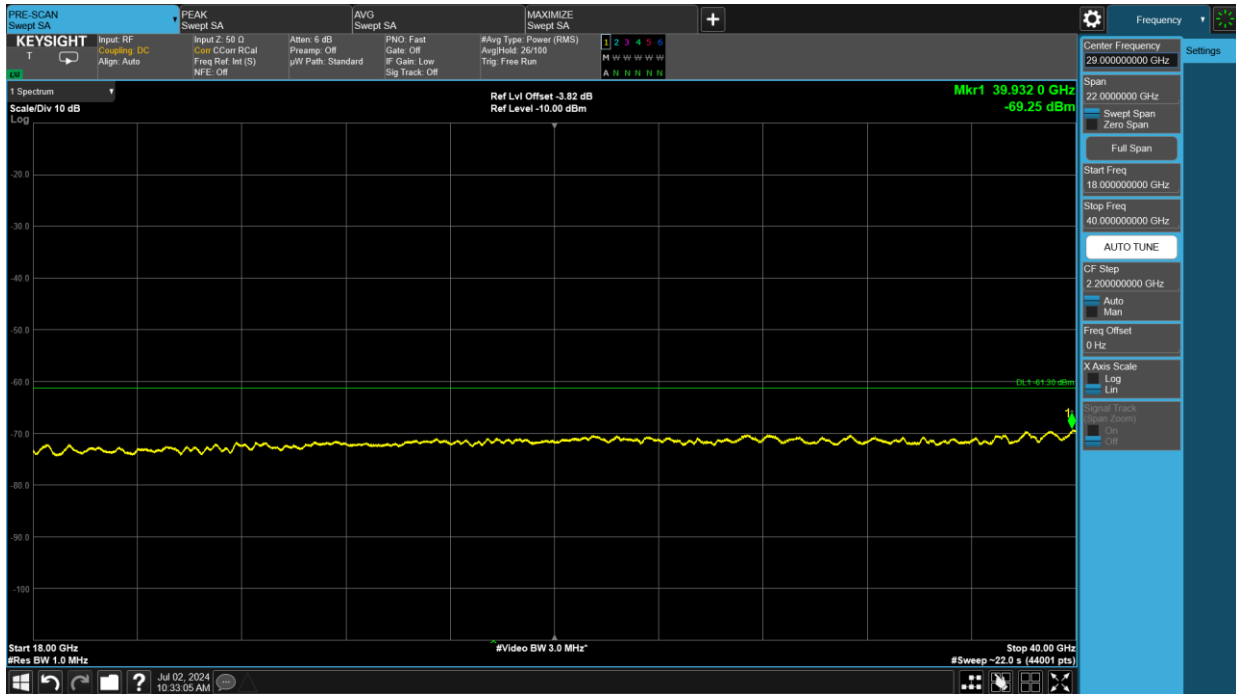

Plot 7-37. Radiated Spurious Emission 18-40GHz (Ch. 9, Config 409, Payload 4093 Ant. Pol. H)

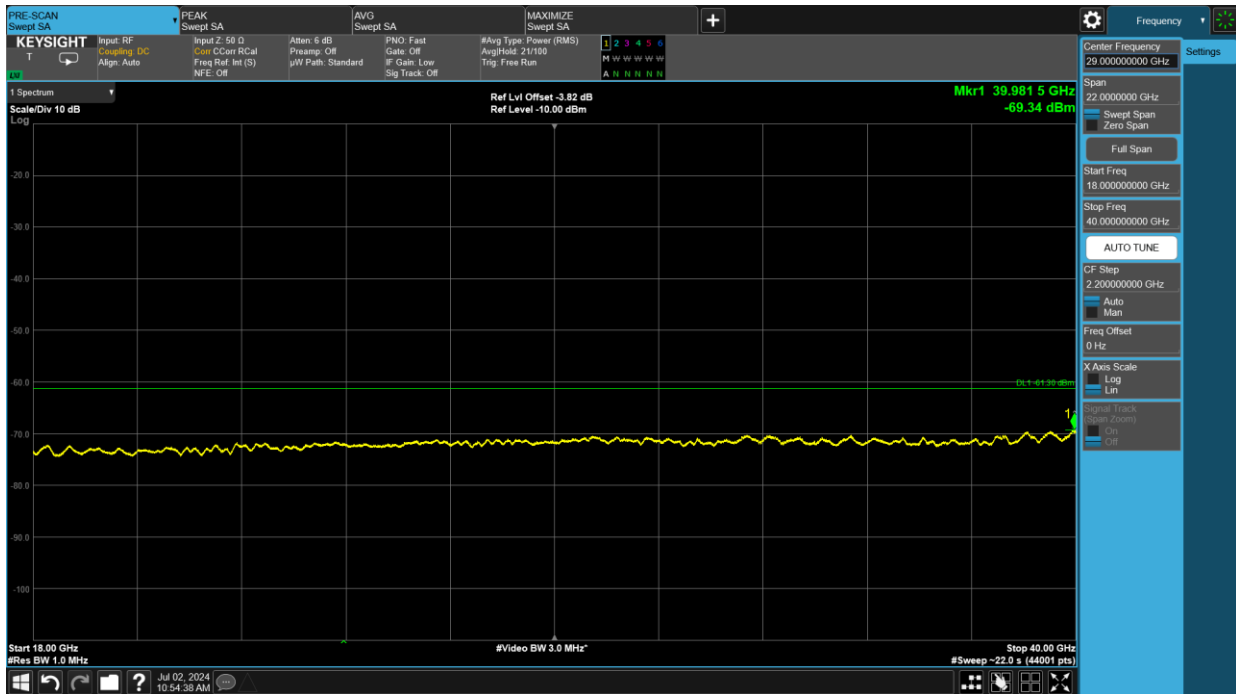

Plot 7-38. Radiated Spurious Emission 18-40GHz (Ch. 9, Config 409, Payload 4093 Ant. Pol. V)

FCC ID: BCG-A2999 IC: 579C-A2999		MEASUREMENT REPORT (CERTIFICATION)	Approved by: Technical Manager
Test Report S/N: 1C2405230020-11.BCG	Test Dates: 6/12/2024 - 7/19/2024	EUT Type: Watch	Page 48 of 63



Radiated Spurious Emission Measurements (960MHz-18GHz)
§15.519(c); RSS-220 [5.3.1(d)]

Distance of Measurements: 0.6 Meters
 Operating Frequency: 6500 MHz
 Channel: 5
 Config: 409
 Payload: 4093

Frequency [MHz]	Detector	Ant. Pol. [H/V]	Antenna Height [cm]	Turntable Azimuth [degree]	Analyzer Level [dBm]	AFCL [dB/m]	Conversion Factor [dB]	Spurious Emission Level [dBm]	Limit [dBm]	Margin [dB]
1250	Avg	V	-	-	-78.68	-3.63	-2.24	-84.55	-75.30	-9.25
1982	Avg	V	-	-	-78.75	-0.60	-2.24	-81.59	-63.30	-18.29
2023	Avg	V	-	-	-78.56	-0.57	-2.24	-81.37	-61.30	-20.07
10450	Avg	V	-	-	-80.75	9.13	-2.24	-73.86	-41.30	-32.56
14212	Avg	V	-	-	-80.71	10.97	-2.24	-71.98	-61.30	-10.68
17024	Avg	V	-	-	-81.25	13.93	-2.24	-69.56	-61.30	-8.26

Table 7-15. Radiated Spurious Emission Measurements 960MHz-18GHz (FCC)

Distance of Measurements: 0.6 Meters
 Operating Frequency: 6500 MHz
 Channel: 5
 Config: 409
 Payload: 4093

Frequency [MHz]	Detector	Ant. Pol. [H/V]	Antenna Height [cm]	Turntable Azimuth [degree]	Analyzer Level [dBm]	AFCL [dB/m]	Conversion Factor [dB]	Spurious Emission Level [dBm]	Limit [dBm]	Margin [dB]
1247	Avg	V	-	-	-78.62	-3.65	-2.24	-84.51	-75.30	-9.21
1979	Avg	V	-	-	-77.91	-0.61	-2.24	-80.77	-70.00	-10.77
2024	Avg	V	-	-	-78.78	-0.57	-2.24	-81.59	-70.00	-11.59
10446	Avg	V	-	-	-81.15	9.13	-2.24	-74.26	-41.30	-32.96
14834	Avg	V	-	-	-81.56	12.12	-2.24	-71.68	-61.30	-10.38
17447	Avg	V	-	-	-81.90	13.32	-2.24	-70.82	-61.30	-9.52

Table 7-16. Radiated Spurious Emission Measurements 960MHz-18GHz (ISED)

FCC ID: BCG-A2999 IC: 579C-A2999		MEASUREMENT REPORT (CERTIFICATION)		Approved by: Technical Manager
Test Report S/N: 1C2405230020-11.BCG	Test Dates: 6/12/2024 - 7/19/2024	EUT Type: Watch		Page 49 of 63

V 10.5 12/15/2021



Radiated Spurious Emission Measurements (960MHz-18GHz)
§15.519 (c); RSS-220 [5.3.1(d)]

Distance of Measurements: 0.6 Meters
 Operating Frequency: 8000 MHz
 Channel: 9
 Config: 409
 Payload: 4093

Frequency [MHz]	Detector	Ant. Pol. [H/V]	Antenna Height [cm]	Turntable Azimuth [degree]	Analyzer Level [dBm]	AFCL [dB/m]	Conversion Factor [dB]	Spurious Emission Level [dBm]	Limit [dBm]	Margin [dB]
1247	Avg	V	-	-	-78.86	-3.65	-2.24	-84.75	-75.30	-9.45
1976	Avg	V	-	-	-78.66	-0.62	-2.24	-81.52	-63.30	-18.22
2026	Avg	V	-	-	-78.66	-0.56	-2.24	-81.46	-61.30	-20.16
10404	Avg	V	-	-	-80.98	9.11	-2.24	-74.11	-41.30	-32.81
14208	Avg	V	-	-	-80.90	11.06	-2.24	-72.08	-61.30	-10.78
17381	Avg	V	-	-	-81.48	13.26	-2.24	-70.46	-61.30	-9.16

Table 7-17. Radiated Spurious Emission Measurements 960MHz-18GHz (FCC)

Distance of Measurements: 0.6 Meters
 Operating Frequency: 8000 MHz
 Channel: 9
 Config: 409
 Payload: 4093

Frequency [MHz]	Detector	Ant. Pol. [H/V]	Antenna Height [cm]	Turntable Azimuth [degree]	Analyzer Level [dBm]	AFCL [dB/m]	Conversion Factor [dB]	Spurious Emission Level [dBm]	Limit [dBm]	Margin [dB]
1252	Avg	V	-	-	-78.59	-3.61	-2.24	-84.44	-75.30	-9.14
1982	Avg	V	-	-	-78.78	-0.60	-2.24	-81.62	-70.00	-11.62
2046	Avg	V	-	-	-78.83	-0.62	-2.24	-81.70	-70.00	-11.70
10384	Avg	V	-	-	-80.94	9.07	-2.24	-74.11	-41.30	-32.81
14094	Avg	V	-	-	-81.00	10.80	-2.24	-72.44	-61.30	-11.14
16881	Avg	V	-	-	-80.90	14.10	-2.24	-69.05	-61.30	-7.75

Table 7-18. Radiated Spurious Emission Measurements 960MHz-18GHz (ISED)

FCC ID: BCG-A2999 IC: 579C-A2999		MEASUREMENT REPORT (CERTIFICATION)		Approved by: Technical Manager
Test Report S/N: 1C2405230020-11.BCG	Test Dates: 6/12/2024 - 7/19/2024	EUT Type: Watch		Page 50 of 63



Radiated Spurious Emission Measurements (Above 18GHz)
§15.519 (c); RSS-220 [5.3.1(d)]

Distance of Measurements: 0.5 Meters
 Operating Frequency: 6500 MHz
 Channel: 5
 Config: 409
 Payload: 4093

Frequency [MHz]	Detector	Ant. Pol. [H/V]	Antenna Height [cm]	Turntable Azimuth [degree]	Analyzer Level [dBm]	AFCL [dB/m]	Conversion Factor [dB]	Spurious Emission Level [dBm]	Limit [dBm]	Margin [dB]
19239	Avg	V	-	-	-62.33	-6.74	-3.82	-72.89	-61.30	-11.59
22305	Avg	V	-	-	-60.94	-7.13	-3.82	-71.89	-61.30	-10.59
28651	Avg	V	-	-	-61.95	-5.99	-3.82	-71.76	-61.30	-10.46
32149	Avg	V	-	-	-63.36	-4.77	-3.82	-71.95	-61.30	-10.65
37748	Avg	V	-	-	-62.03	-5.71	-3.82	-71.56	-61.30	-10.26

Table 7-19. Radiated Spurious Emission Measurements 18-40GHz

Distance of Measurements: 0.5 Meters
 Operating Frequency: 8000 MHz
 Channel: 9
 Config: 409
 Payload: 4093

Frequency [MHz]	Detector	Ant. Pol. [H/V]	Antenna Height [cm]	Turntable Azimuth [degree]	Analyzer Level [dBm]	AFCL [dB/m]	Conversion Factor [dB]	Spurious Emission Level [dBm]	Limit [dBm]	Margin [dB]
18859	Avg	V	-	-	-62.60	-6.56	-3.82	-72.98	-61.30	-11.68
23308	Avg	V	-	-	-61.23	-7.31	-3.82	-72.36	-61.30	-11.06
28384	Avg	V	-	-	-61.82	-5.90	-3.82	-71.54	-61.30	-10.24
31956	Avg	V	-	-	-61.93	-5.22	-3.82	-70.97	-61.30	-9.67
37063	Avg	V	-	-	-62.59	-6.02	-3.82	-72.43	-61.30	-11.13

Table 7-20. Radiated Spurious Emission Measurements 18-40GHz

FCC ID: BCG-A2999 IC: 579C-A2999		MEASUREMENT REPORT (CERTIFICATION)	Approved by: Technical Manager
Test Report S/N: 1C2405230020-11.BCG	Test Dates: 6/12/2024 - 7/19/2024	EUT Type: Watch	Page 51 of 63

V 10.5 12/15/2021

7.7 Radiated Spurious Emissions Measurements – Below 960MHz

§15.209; RSS-Gen [8.9]

Test Overview and Limit

All out of band radiated spurious emissions are measured with a spectrum analyzer connected to a receive antenna while the EUT is operating at its maximum duty cycle, at maximum power, and at the appropriate frequencies. All data rates and modes were investigated for radiated spurious emissions. Only the radiated emissions of the configuration that produced the worst case emissions are reported in this section.

All out of band emissions appearing in a restricted band as specified in Section 15.205 of the Title 47 CFR and Table 7 of RSS-Gen (8.10) must not exceed the limits shown in Table 7-21 per Section 15.209 and RSS-Gen (8.9).

Frequency	Field Strength [μ V/m]	Measured Distance [Meters]
0.009 – 0.490 MHz	2400/F (kHz)	300
0.490 – 1.705 MHz	24000/F (kHz)	30
1.705 – 30.00 MHz	30	30
30.00 – 88.00 MHz	100	3
88.00 – 216.0 MHz	150	3
216.0 – 960.0 MHz	200	3
Above 960.0 MHz	500	3

Table 7-21. Radiated Limits

Test Procedures Used

ANSI C63.10-2020

Test Settings

Quasi-Peak Field Strength Measurements

1. Analyzer center frequency was set to the frequency of the radiated spurious emission of interest
2. RBW = 120kHz (for emissions from 30MHz – 1GHz)
3. Detector = quasi-peak
4. Sweep time = auto couple
5. Trace mode = max hold
6. Trace was allowed to stabilize

Peak Field Strength Measurements

1. Analyzer center frequency was set to the frequency of the radiated spurious emission of interest
2. RBW = 120kHz (for emissions from 30MHz – 1GHz)
3. VBW = 300kHz
4. Detector = peak
5. Sweep time = auto couple
6. Trace mode = max hold
7. Trace was allowed to stabilize

FCC ID: BCG-A2999 IC: 579C-A2999		MEASUREMENT REPORT (CERTIFICATION)	Approved by: Technical Manager
Test Report S/N: 1C2405230020-11.BCG	Test Dates: 6/12/2024 - 7/19/2024	EUT Type: Watch	Page 52 of 63

Test Setup

The EUT and measurement equipment were set up as shown in the diagrams below.

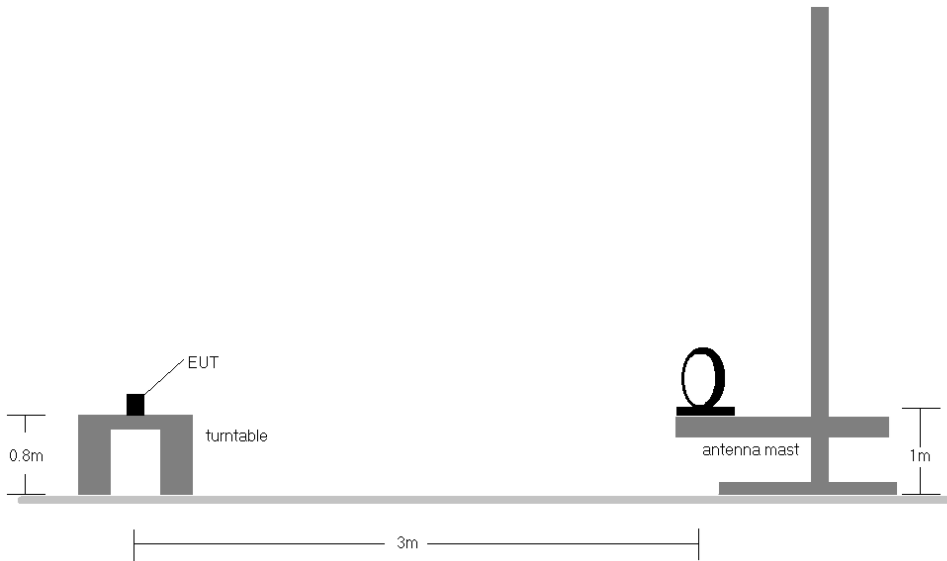

Figure 7-6. Radiated Test Setup < 30Mhz

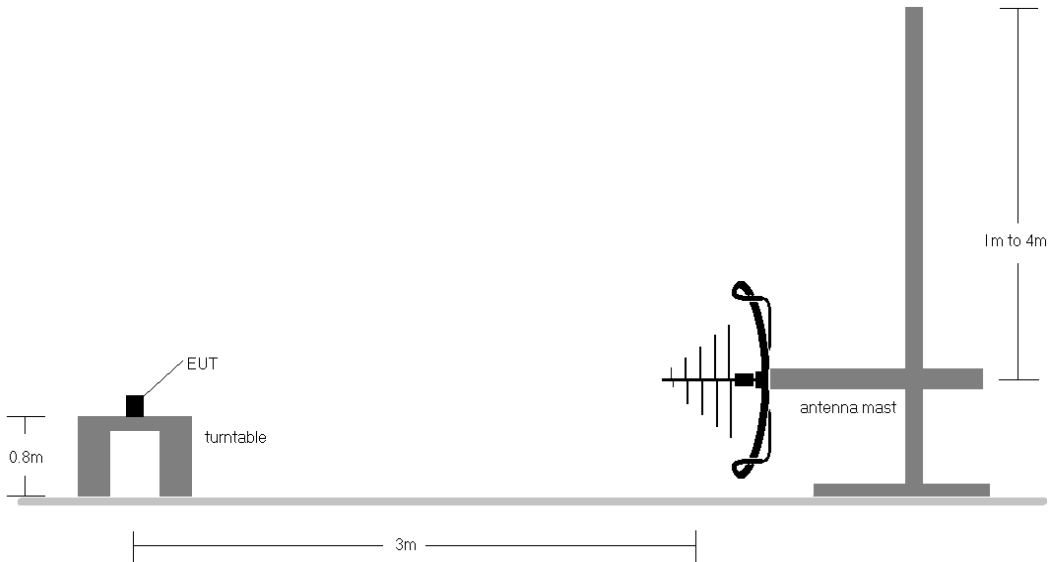

Figure 7-7. Radiated Test Setup < 1GHz

FCC ID: BCG-A2999 IC: 579C-A2999	 MEASUREMENT REPORT (CERTIFICATION)		Approved by: Technical Manager
Test Report S/N: 1C2405230020-11.BCG	Test Dates: 6/12/2024 - 7/19/2024	EUT Type: Watch	Page 53 of 63

Test Notes

1. All emissions lying in restricted bands specified in §15.205 and RSS-Gen(8.10) are below the limit shown in Table 7-21.
2. The broadband receive antenna is manipulated through vertical and horizontal polarizations during the tests. The EUT is manipulated through three orthogonal planes. For below 30MHz the loop antenna was positioned in 3 orthogonal planes (X front, Y side, Z top) to determine the orientation resulting in the worst case emissions.
3. This unit was tested with its standard battery.
4. The spectrum is investigated using a peak detector and final measurements are recorded using CISPR quasi peak detector for emissions within 6dB of the limit.
5. Emissions were measured at a 3 meter test distance.
6. Emissions are investigated while operating on the center channel of the mode, band, and modulation that produced the worst case results during the transmitter spurious emissions testing.
7. No spurious emissions were detected within 20dB of the limit below 30MHz.
8. The results recorded using the broadband antenna is known to correlate with the results obtained by using a tuned dipole with an acceptable degree of accuracy. The VSWR for the measurement antenna was found to be less than 2:1.
9. Both configurations below were investigated, and the worst case has been reported.
 - a. EUT powered by AC/DC adaptor via USB-C cable with magnetic charger
 - b. EUT powered by host PC via USB-C cable with magnetic charger
10. All modes of operation were investigated and the worst-case emissions are reported.

Sample Calculations

Determining Spurious Emissions Levels

- Field Strength Level $_{[dB\mu V/m]} = \text{Analyzer Level }_{[dBm]} + 107 + \text{AFCL }_{[dB/m]}$
- $\text{AFCL }_{[dB/m]} = (\text{Antenna Factor }_{[dB/m]} + \text{Cable Loss }_{[dB]} + \text{Attenuator }_{[dB]}) - \text{Preamplifier Gain }_{[dB]}$
- $\text{Margin }_{[dB]} = \text{Field Strength Level }_{[dB\mu V/m]} - \text{Limit }_{[dB\mu V/m]}$

FCC ID: BCG-A2999 IC: 579C-A2999	 MEASUREMENT REPORT (CERTIFICATION)	Approved by: Technical Manager
Test Report S/N: 1C2405230020-11.BCG		Test Dates: 6/12/2024 - 7/19/2024

Radiated Spurious Emissions Measurements (Below 1GHz)

§15.209; RSS-Gen [8.9]

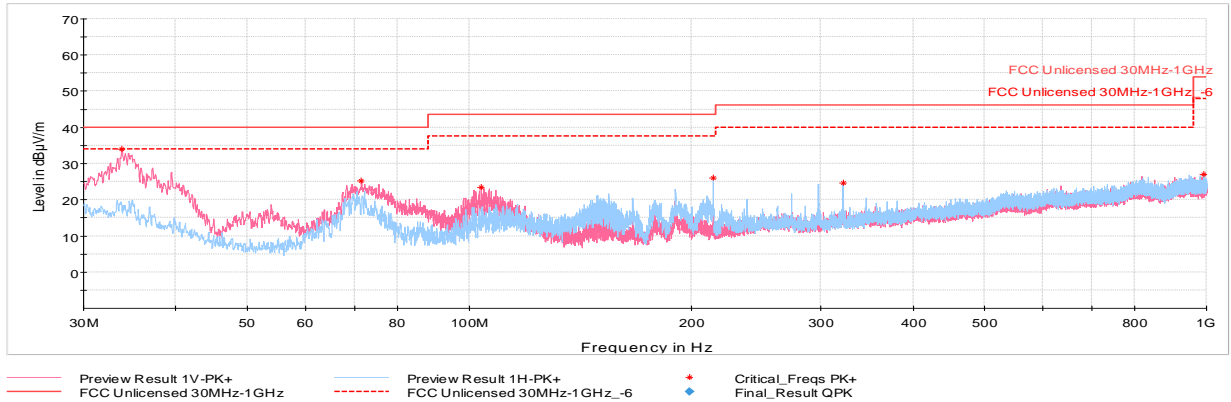

Plot 7-39. Radiated Spurious Emission 30-960MHz (Ch. 5, Config 409, Payload 4093 with AC/DC Adapter + Magnetic Charger)

Frequency [MHz]	Detector	Ant. Pol. [H/V]	Antenna Height [cm]	Turntable Azimuth [degree]	Analyzer Level [dBm]	AFCL [dB/m]	Field Strength [dBµV/m]	Limit [dBµV/m]	Margin [dB]
33.83	Max-Peak	V	100	22	-55.46	-17.59	33.95	40.00	-6.05
71.47	Max-Peak	V	100	15	-58.56	-23.17	25.27	40.00	-14.73
103.82	Max-Peak	V	100	101	-62.85	-20.80	23.35	43.52	-20.17
214.35	Max-Peak	H	100	128	-63.28	-17.75	25.97	43.52	-17.55
321.39	Max-Peak	H	100	234	-68.72	-13.63	24.65	46.02	-21.37
990.79	Max-Peak	H	100	234	-76.76	-3.24	27.00	53.98	-26.98

Table 7-22. Radiated Spurious Emission 30-960MHz (Ch. 5, Config 409, Payload 4093 with AC/DC Adapter + Magnetic Charger)

FCC ID: BCG-A2999 IC: 579C-A2999	 MEASUREMENT REPORT (CERTIFICATION)		Approved by: Technical Manager
Test Report S/N: 1C2405230020-11.BCG	Test Dates: 6/12/2024 - 7/19/2024	EUT Type: Watch	Page 55 of 63

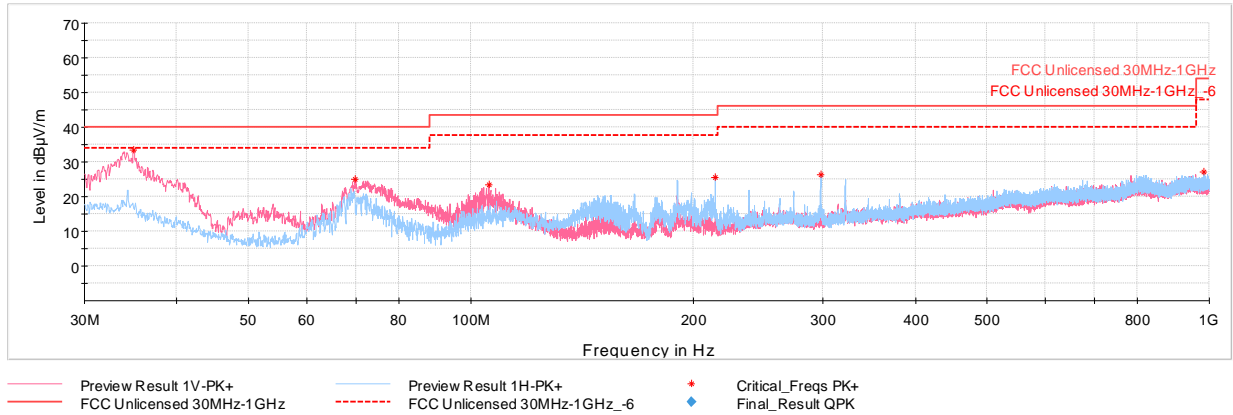

Plot 7-40. Radiated Spurious Emission 30-960MHz (Ch. 9, Config 409, Payload with AC/DC Adapter + Magnetic Charger)

Frequency [MHz]	Detector	Ant. Pol. [H/V]	Antenna Height [cm]	Turntable Azimuth [degree]	Analyzer Level [dBm]	AFCL [dB/m]	Field Strength [dBµV/m]	Limit [dBµV/m]	Margin [dB]
34.95	Max-Peak	V	100	81	-55.26	-18.36	33.38	40.00	-6.62
69.82	Max-Peak	V	100	16	-58.49	-23.40	25.11	40.00	-14.89
105.81	Max-Peak	V	100	109	-62.99	-20.66	23.35	43.52	-20.17
214.20	Max-Peak	H	100	132	-63.76	-17.75	25.49	43.52	-18.03
297.67	Max-Peak	H	100	239	-66.18	-14.52	26.30	46.02	-19.72
982.78	Max-Peak	H	200	298	-76.59	-3.23	27.18	53.98	-26.80

Table 7-23. Radiated Spurious Emission 30-960MHz (Ch. 9, Config 409, Payload 4093 with AC/DC Adapter + Magnetic Charger)

FCC ID: BCG-A2999 IC: 579C-A2999		MEASUREMENT REPORT (CERTIFICATION)	Approved by: Technical Manager
Test Report S/N: 1C2405230020-11.BCG	Test Dates: 6/12/2024 - 7/19/2024	EUT Type: Watch	Page 56 of 63

7.8 AC Line-Conducted Emission Measurement

§15.207; RSS-Gen [8.8]

Test Overview and Limit

All AC line conducted spurious emissions are measured with a receiver connected to a grounded LISN while the EUT is operating at its maximum duty cycle, at maximum power, and at the appropriate frequencies. All data rates and modes were investigated for AC Line conducted spurious emissions. Only the conducted emissions of the configuration that produced the worst case emissions are reported in this section.

All conducted emissions must not exceed the limits shown in the table below, per Section 15.207 and RSS-Gen (8.8).

Frequency of emission (MHz)	Conducted Limit (dB μ V)	
	Quasi-peak	Average
0.15 – 0.5	66 to 56*	56 to 46*
0.5 – 5	56	46
5 – 30	60	50

Table 7-24. Conducted Limits

*Decreases with the logarithm of the frequency.

Test Procedures Used

ANSI C63.10-2020, Section 6.2

Test Settings

Quasi-Peak Measurements

1. Analyzer center frequency was set to the frequency of the spurious emission of interest
2. RBW = 9kHz (for emissions from 150kHz – 30MHz)
3. Detector = quasi-peak
4. Sweep time = auto couple
5. Trace mode = max hold
6. Trace was allowed to stabilize

Average Measurements

1. Analyzer center frequency was set to the frequency of the spurious emission of interest
2. RBW = 9kHz (for emissions from 150kHz – 30MHz)
3. Detector = RMS
4. Sweep time = auto couple
5. Trace mode = max hold
6. Trace was allowed to stabilize

FCC ID: BCG-A2999 IC: 579C-A2999		MEASUREMENT REPORT (CERTIFICATION)	Approved by: Technical Manager
Test Report S/N: 1C2405230020-11.BCG	Test Dates: 6/12/2024 - 7/19/2024	EUT Type: Watch	Page 57 of 63

V 10.5 12/15/2021

Test Setup

The EUT and measurement equipment were set up as shown in the diagram below.

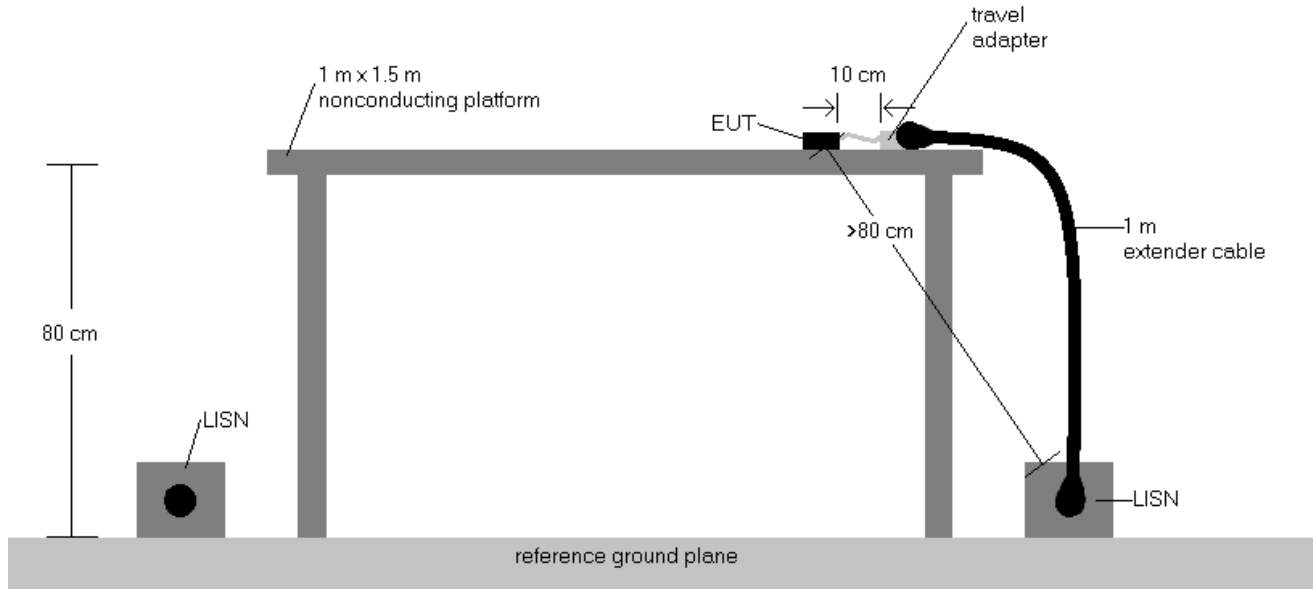

Figure 7-8. Test Instrument & Measurement Setup

Test Notes

1. All modes of operation were investigated and the worst-case emissions are reported. The emissions found were not affected by the choice of channel used during testing.
2. The limit for an intentional radiator from 150kHz to 30MHz are specified in Part 15.207 and RSS-Gen (8.8).
3. $\text{Corr. (dB)} = \text{Cable loss (dB)} + \text{LISN insertion factor (dB)}$
4. $\text{QP/AV Level (dB}\mu\text{V)} = \text{QP/AV Analyzer/Receiver Level (dB}\mu\text{V)} + \text{Corr. (dB)}$
5. $\text{Margin (dB)} = \text{QP/AV Limit (dB}\mu\text{V)} - \text{QP/AV Level (dB}\mu\text{V)}$
6. Traces shown in plot are made using a quasi-peak and average detectors
7. Deviations to the Specifications: None.
8. Both configurations below were investigated, and the worst case has been reported.
 - a. EUT powered by AC/DC adapter via USB-C cable with magnetic charger
 - b. EUT powered by host PC via USB-C cable with magnetic charger

FCC ID: BCG-A2999 IC: 579C-A2999		MEASUREMENT REPORT (CERTIFICATION)	Approved by: Technical Manager
Test Report S/N: 1C2405230020-11.BCG	Test Dates: 6/12/2024 - 7/19/2024	EUT Type: Watch	Page 58 of 63

V 10.5 12/15/2021

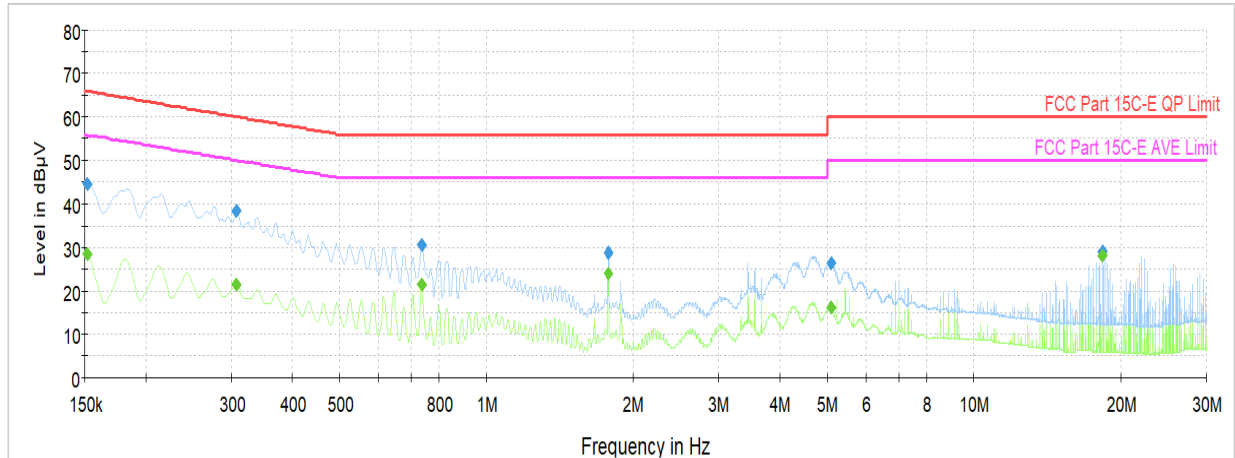

— Preview Result 2-AVG — Preview Result 1-QPK * Critical_Freqs AVG + Critical_Freqs QPK
— FCC Part 15C-E QP Limit — FCC Part 15C-E AVE Limit ◆ Final_Result QPK ◆ Final_Result AVG

Plot 7-41. AC Line Conducted (Ch. 5, Config 409, Payload 4093 L1, with AC/DC Adapter + Magnetic Charger)

Frequency [MHz]	Process State	QuasiPeak [dBµV]	Average [dBµV]	Limit [dBµV]	Margin [dB]	Line	PE
0.152	FINAL	—	28.31	55.88	-27.57	L1	GND
0.152	FINAL	44.7	—	65.88	-21.20	L1	GND
0.308	FINAL	—	21.34	50.04	-28.70	L1	GND
0.308	FINAL	38.3	—	60.04	-21.77	L1	GND
0.737	FINAL	—	21.50	46.00	-24.50	L1	GND
0.737	FINAL	30.5	—	56.00	-25.54	L1	GND
1.777	FINAL	28.8	—	56.00	-27.17	L1	GND
1.777	FINAL	—	24.17	46.00	-21.83	L1	GND
5.096	FINAL	26.3	—	60.00	-33.66	L1	GND
5.096	FINAL	—	16.11	50.00	-33.89	L1	GND
18.332	FINAL	—	28.13	50.00	-21.87	L1	GND
18.332	FINAL	29.1	—	60.00	-30.89	L1	GND

Table 7-25. AC Line Conducted Data (Ch. 5, Config 409, Payload 4093 L1, with AC/DC Adapter + Magnetic Charger)

FCC ID: BCG-A2999 IC: 579C-A2999		MEASUREMENT REPORT (CERTIFICATION)	Approved by: Technical Manager
Test Report S/N: 1C2405230020-11.BCG	Test Dates: 6/12/2024 - 7/19/2024	EUT Type: Watch	Page 59 of 63

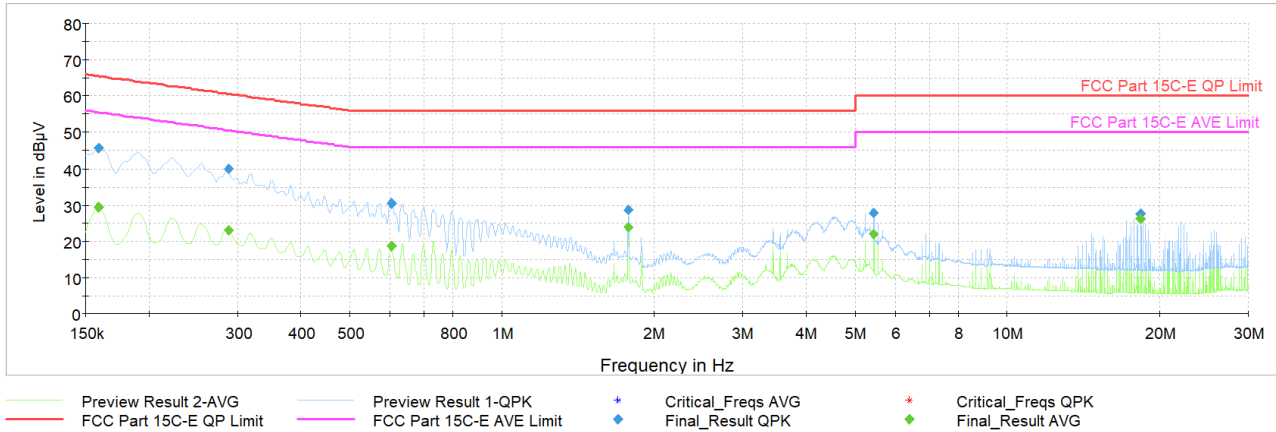

Plot 7-42. AC Line Conducted (Ch. 5, Config 409, Payload 4093 N, with AC/DC Adapter + Magnetic Charger)

Frequency [MHz]	Process State	QuasiPeak [dBµV]	Average [dBµV]	Limit [dBµV]	Margin [dB]	Line	PE
0.159	FINAL	—	29.32	55.52	-26.20	N	GND
0.159	FINAL	45.7	—	65.52	-19.80	N	GND
0.287	FINAL	—	23.20	50.60	-27.40	N	GND
0.287	FINAL	39.9	—	60.60	-20.69	N	GND
0.605	FINAL	—	18.73	46.00	-27.27	N	GND
0.605	FINAL	30.5	—	56.00	-25.52	N	GND
1.777	FINAL	28.6	—	56.00	-27.45	N	GND
1.777	FINAL	—	23.93	46.00	-22.07	N	GND
5.444	FINAL	27.7	—	60.00	-32.30	N	GND
5.444	FINAL	—	22.04	50.00	-27.96	N	GND
18.332	FINAL	—	26.29	50.00	-23.71	N	GND
18.332	FINAL	27.5	—	60.00	-32.50	N	GND

Table 7-26. AC Line Conducted Data (Ch. 5, Config 409, Payload 4093 N, with AC/DC Adapter + Magnetic Charger)

FCC ID: BCG-A2999 IC: 579C-A2999		MEASUREMENT REPORT (CERTIFICATION)	Approved by: Technical Manager
Test Report S/N: 1C2405230020-11.BCG	Test Dates: 6/12/2024 - 7/19/2024	EUT Type: Watch	Page 60 of 63

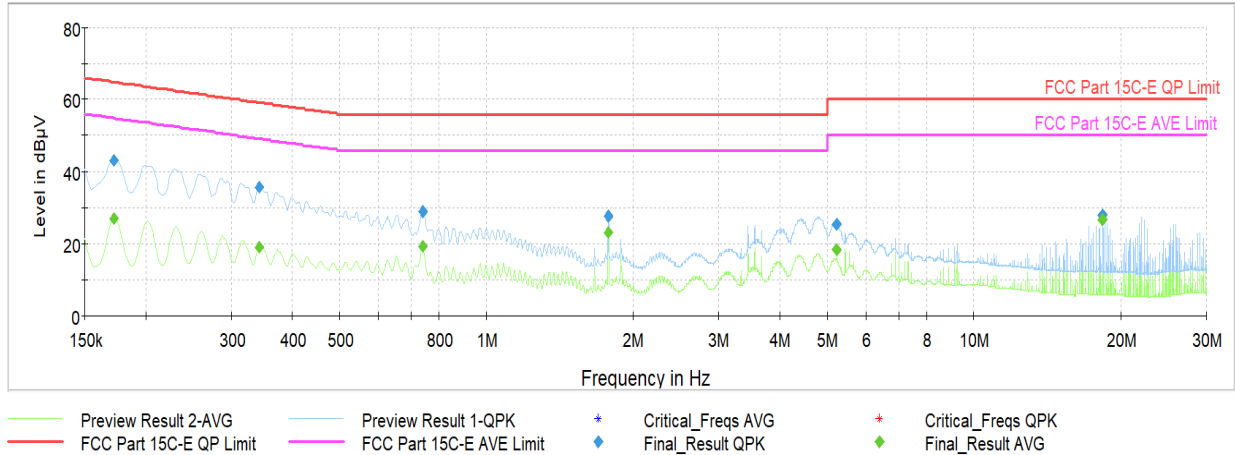

Plot 7-43. AC Line Conducted (Ch. 9, Config 409, Payload 4093 L1, with AC/DC Adapter + Magnetic Charger)

Frequency [MHz]	Process State	QuasiPeak [dBµV]	Average [dBµV]	Limit [dBµV]	Margin [dB]	Line	PE
0.173	FINAL	—	27.06	54.84	-27.78	L1	GND
0.173	FINAL	42.9	—	64.84	-21.94	L1	GND
0.341	FINAL	—	18.94	49.17	-30.24	L1	GND
0.341	FINAL	35.7	—	59.17	-23.47	L1	GND
0.742	FINAL	—	19.18	46.00	-26.83	L1	GND
0.742	FINAL	28.9	—	56.00	-27.13	L1	GND
1.777	FINAL	27.6	—	56.00	-28.43	L1	GND
1.777	FINAL	—	23.02	46.00	-22.98	L1	GND
5.222	FINAL	25.4	—	60.00	-34.65	L1	GND
5.222	FINAL	—	18.17	50.00	-31.83	L1	GND
18.332	FINAL	—	26.72	50.00	-23.28	L1	GND
18.332	FINAL	27.9	—	60.00	-32.13	L1	GND

Table 7-27. AC Line Conducted Data (Ch. 9, Config 409, Payload 4093 L1, with AC/DC Adapter + Magnetic Charger)

FCC ID: BCG-A2999 IC: 579C-A2999		MEASUREMENT REPORT (CERTIFICATION)	Approved by: Technical Manager
Test Report S/N: 1C2405230020-11.BCG	Test Dates: 6/12/2024 - 7/19/2024	EUT Type: Watch	Page 61 of 63

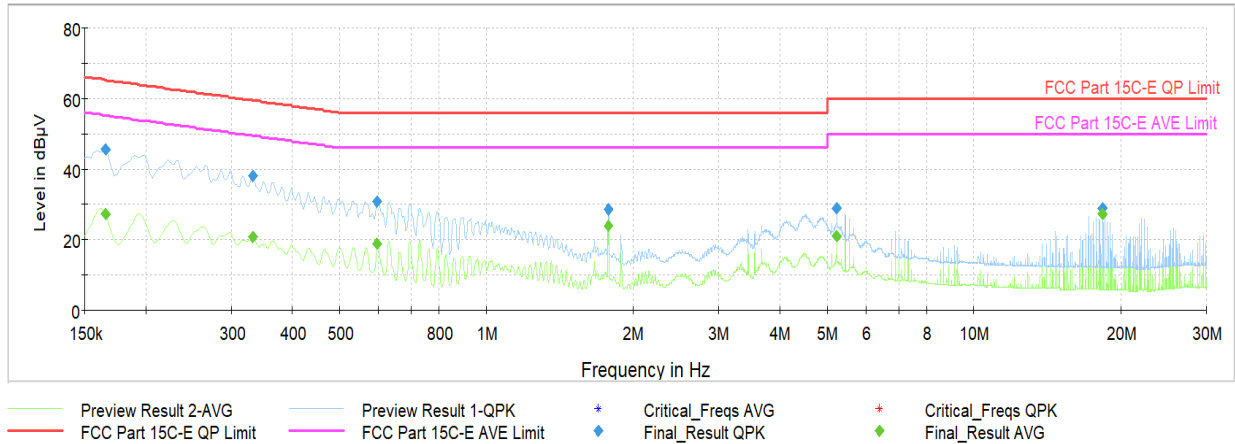

Plot 7-44. AC Line Conducted Plot (Ch. 9, Config 409, Payload 4093 N, with AC/DC Adapter + Magnetic Charger)

Frequency [MHz]	Process State	QuasiPeak [dBµV]	Average [dBµV]	Limit [dBµV]	Margin [dB]	Line	PE
0.166	FINAL	—	27.32	55.17	-27.85	N	GND
0.166	FINAL	45.4	—	65.17	-19.79	N	GND
0.332	FINAL	—	20.70	49.40	-28.70	N	GND
0.332	FINAL	38.0	—	59.40	-21.39	N	GND
0.598	FINAL	—	18.79	46.00	-27.21	N	GND
0.598	FINAL	30.7	—	56.00	-25.33	N	GND
1.777	FINAL	28.6	—	56.00	-27.37	N	GND
1.777	FINAL	—	23.98	46.00	-22.02	N	GND
5.222	FINAL	28.7	—	60.00	-31.26	N	GND
5.222	FINAL	—	21.03	50.00	-28.97	N	GND
18.332	FINAL	—	27.35	50.00	-22.65	N	GND
18.332	FINAL	28.8	—	60.00	-31.25	N	GND

Table 7-28. AC Line Conducted Data (Ch. 9, Config 409, Payload 4093 N, with AC/DC Adapter + Magnetic Charger)

FCC ID: BCG-A2999 IC: 579C-A2999		MEASUREMENT REPORT (CERTIFICATION)	Approved by: Technical Manager
Test Report S/N: 1C2405230020-11.BCG	Test Dates: 6/12/2024 - 7/19/2024	EUT Type: Watch	Page 62 of 63

8.0 CONCLUSION

The data collected relate only the item(s) tested and show that the **Apple Watch FCC ID: BCG-A2999** and **IC: 579C-A2999** is in compliance with Part 15 Subpart C (15.519) of the FCC Rules and RSS-220 of the Innovation, Science and Economic Development Canada Rules.

FCC ID: BCG-A2999 IC: 579C-A2999	 MEASUREMENT REPORT (CERTIFICATION)	Approved by: Technical Manager
Test Report S/N: 1C2405230020-11.BCG		Test Dates: 6/12/2024 - 7/19/2024

V 10.5 12/15/2021