



MEASUREMENT REPORT
FCC PART 15.519 / ISED RSS-220 Ultra-Wideband

Applicant Name:

Apple Inc.
One Apple Park Way
Cupertino, CA 95014
United States

Date of Testing:

06/08/2021-08/06/2021

Test Site/Location:

PCTEST Lab. Morgan Hill, CA, USA

Test Report Serial No.:

1C2106070041-08.BCG

FCC ID:	BCG-A2473
IC:	579C-A2473
APPLICANT:	Apple Inc.

Application Type:

Certification

Model/HVIN:

A2473

EUT Type:

Watch

Operational Frequency:

6489.6MHz (Ch 5) and 7987.2MHz (Ch 9)

FCC Classification:

Ultra-Wideband Transmitter (UWB)

FCC Rule Part(s):

Part 15 Subpart F (15.519)

ISED Specification:

RSS-Gen Issue 5, RSS-220 Issue 1

RSS-220 Subclass:

Hand-held Communication Devices

Test Procedure(s):

ANSI C63.10-2013, KDB 393764 D01 v02

This equipment has been shown to be capable of compliance with the applicable technical standards as indicated in the measurement report and was tested in accordance with the measurement procedures specified in ANSI C63.10-2013 and KDB 393764 D01 v02. Test results reported herein relate only to the item(s) tested.

I attest to the accuracy of data. All measurements reported herein were performed by me or were made under my supervision and are correct to the best of my knowledge and belief. I assume full responsibility for the completeness of these measurements and vouch for the qualifications of all persons taking them.



Randy Ortanez
President



FCC ID: BCG-A2473 IC: 579C-A2473	 MEASUREMENT REPORT (CERTIFICATION)	Approved by: Quality Manager
Test Report S/N: 1C2106070041-08.BCG	Test Dates: 06/08/2021-08/06/2021	EUT Type: Watch
		Page 1 of 63

TABLE OF CONTENTS

1.0	INTRODUCTION	3
1.1	Scope	3
1.2	PCTEST Test Location.....	3
1.3	Test Facility / Accreditations.....	3
2.0	PRODUCT INFORMATION.....	4
2.1	Equipment Description	4
2.2	Device Capabilities.....	4
2.3	Antenna Description	5
2.4	Test Support Equipment.....	5
2.5	Test Configuration	6
2.6	Software and Firmware	6
2.7	EMI Suppression Device(s)/Modifications	6
3.0	DESCRIPTION OF TESTS	7
3.1	Evaluation Procedure	7
3.2	AC Line Conducted Emissions	7
3.3	Radiated Emissions.....	8
3.4	Environmental Conditions.....	8
4.0	ANTENNA REQUIREMENTS	9
5.0	MEASUREMENT UNCERTAINTY	10
6.0	TEST EQUIPMENT CALIBRATION DATA	11
7.0	TEST RESULTS	12
7.1	Summary.....	12
7.2	10dBc Bandwidth Measurement.....	13
7.3	Bandwidth Measurement.....	17
7.4	Maximum Peak and Average Radiated Power (EIRP)	20
7.4.1	Peak Radiated Power Measurement	22
7.4.2	Average Radiated Power Measurement.....	24
7.5	Cease Transmission Time.....	26
7.6	Radiated Spurious Emissions – Above 960MHz	31
7.6.1	Radiated Spurious Emissions (960MHz – 18GHz).....	34
7.6.2	Simultaneous Tx Radiated Spurious Emission Measurements	49
7.7	Radiated Spurious Emissions – Below 960MHz.....	51
7.7.1	Radiated Spurious Emissions (Below 960MHz)	54
7.7.2	Simultaneous Tx Radiated Spurious Emissions (Below 960 MHz).....	56
7.8	AC Line-Conducted Emission Measurement.....	57
8.0	CONCLUSION.....	63

FCC ID: BCG-A2473 IC: 579C-A2473		MEASUREMENT REPORT (CERTIFICATION)	Approved by: Quality Manager
Test Report S/N: 1C2106070041-08.BCG	Test Dates: 06/08/2021-08/06/2021	EUT Type: Watch	Page 2 of 63

1.0 INTRODUCTION

1.1 Scope

Measurement and determination of electromagnetic emissions (EMC) of radio frequency devices including intentional and/or unintentional radiators for compliance with the technical rules and regulations of the Federal Communications Commission and the Innovation, Science and Economic Development Canada.

1.2 PCTEST Test Location

These measurement tests were conducted at the PCTEST facility located at 18855 Adams Court, Morgan Hill, CA 95037. The measurement facility is compliant with the test site requirements specified in ANSI C63.4-2014 and KDB 414788 D01 v01r01.

1.3 Test Facility / Accreditations

Measurements were performed at PCTEST located in Morgan Hill, CA 95037, U.S.A.

- PCTEST is an ISO 17025-2017 accredited test facility under the American Association for Laboratory Accreditation (A2LA) with Certificate number 2041.02 for Specific Absorption Rate (SAR), Hearing Aid Compatibility (HAC) testing, where applicable, and Electromagnetic Compatibility (EMC) testing for FCC and Innovation, Science, and Economic Development Canada rules.
- PCTEST TCB is a Telecommunication Certification Body (TCB) accredited to ISO/IEC 17065-2012 by A2LA (Certificate number 2041.03) in all scopes of FCC Rules and ISED Standards (RSS).
- PCTEST facility is a registered (22831) test laboratory with the site description on file with ISED.

FCC ID: BCG-A2473 IC: 579C-A2473		MEASUREMENT REPORT (CERTIFICATION)	Approved by: Quality Manager
Test Report S/N: 1C2106070041-08.BCG	Test Dates: 06/08/2021-08/06/2021	EUT Type: Watch	Page 3 of 63

2.0 PRODUCT INFORMATION

2.1 Equipment Description

The Equipment Under Test (EUT) is the **Apple Watch FCC ID: BCG-A2473** and **IC: 579C-A2473**. The test data contained in this report pertains only to the emissions due to the EUT's Ultra-Wideband (UWB) transmitter.

Test Device Serial No.: CK0F577LV9, WXL9V9V4CN, VXCRXL57CK

2.2 Device Capabilities

This device contains the following capabilities:

802.11b/g/n WLAN, 802.11a/n UNII, Bluetooth (1x, EDR, HDR4, HDR8, LE1M, LE2M), NFC, UWB, 60.5GHz Transmitter

For ISSED, this device is under subclass 5.3 Hand-held Communication Devices of RSS-220

Data Port UWB Radio Terminal Access: No

Ch.	Frequency [MHz]	Config	Payload	
5	6500	0	25	
			65	
			125	
		1	45	
			85	
			125	
			2	125
			3	125
4	0			
5	0			
9	8000	0	25	
			65	
			125	
		1	45	
			85	
			125	
			2	125
			3	125
4	0			
5	0			

Table 2-1. UWB Frequency / Channel Operations

FCC ID: BCG-A2473 IC: 579C-A2473	 PCTEST Proud to be part of  element	MEASUREMENT REPORT (CERTIFICATION)	Approved by: Quality Manager
Test Report S/N: 1C2106070041-08.BCG	Test Dates: 06/08/2021-08/06/2021	EUT Type: Watch	Page 4 of 63

Notes:

1. This device supports simultaneous multi radio transmission feature, which allows multiple radios to transmit simultaneously at the same antenna. The table below shows all the possible multi radio TX combinations:

Simultaneous Tx Config	Antenna FCM			
	WLAN	Bluetooth	UNII	UWB
	802.11b/g/n	BDR, EDR, HDR4/8, LE	802.11a/n	Ch.5, Ch.9
Config 1	✓	✗	✗	✓
Config 2	✗	✓	✗	✓
Config 3	✗	✓	✓	✗

Table 2-2. Simultaneous Transmission Configurations

✓ = Support; ✗ = NOT Support

2.3 Antenna Description

Following antenna gains provided by manufacturer were used for testing.

Frequency [GHz]	Antenna Gain (dBi)
6250-6750	-6.3
7750-8250	-4.9

Table 2-3. Highest Antenna Gain

2.4 Test Support Equipment

1	Apple Macbook	Model:	A1398	S/N:	C2QKP008F6F3
	w/AC/DC Adapter	Model:	A1435	S/N:	N/A
2	Apple USB-C cable	Model:	N/A	S/N:	N/A
	w/ Charging Dock	Model:	A2687	S/N:	FV411420544MW6M4H
	w/Dock	Model:	X241	S/N:	N/A
3	Apple Magnetic Charger	Model:	A2515	S/N:	DLC035200UJMFROAJ
	Apple Magnetic Charger	Model:	A2515	S/N:	DLC035202KRMFROA2
4	Pathfinder Falcon	Model:	920-098626-01	S/N:	DLC034200APQ6PM1E
	SiP Socket	Model:	P2 X2010S PF 165	S/N:	NA
5	Store Bracelet Assy1	Model:	N/A	S/N:	DLC1197001R19G21N

Table 2-4. Test Support Equipment List

FCC ID: BCG-A2473 IC: 579C-A2473		MEASUREMENT REPORT (CERTIFICATION)	Approved by: Quality Manager
Test Report S/N: 1C2106070041-08.BCG	Test Dates: 06/08/2021-08/06/2021	EUT Type: Watch	Page 5 of 63

2.5 Test Configuration

The EUT was tested per the guidance of ANSI C63.10-2013 and KDB 393764 D01 v02. ANSI C63.10-2013 was used to reference the appropriate EUT setup for radiated spurious emissions testing and AC line conducted testing. See Sections 3.2 for AC line conducted emissions test setups, 3.3 for radiated emissions test setups.

The worst case configuration was investigated for various types of wristbands, metal and non-metal wristbands. The EUT was also investigated with and without magnetic charger. The worst case configuration found was used for all testing.

For emissions from 960MHz – 18GHz, channel 5 and channel 9 were tested with highest power and worst case configuration. The emissions below 960MHz and above 18GHz were tested with the highest transmitting power and the worst case configuration.

The EUT was manipulated through three orthogonal planes of X-orientation (flatbed), Y-orientation (landscape), and Z-orientation (portrait) during the testing. Only the worst case emissions were reported in this test report.

For AC line conducted emission and radiated emission below 960MHz, following configuration were investigated and the worst case was reported.

- EUT powered by AC/DC adapter via USB-C cable with magnetic charger
- EUT powered by host PC via USB-C cable with magnetic charger

All possible simultaneous transmission configurations have been investigated and the worst case config has been reported.

Description	WLAN	UWB
Antenna	FCM	FCM
Channel	6	5
Operating Frequency (MHz)	2437	6500
Mode/Modulation	802.11b	Config 3/Payload125

Table 2-5. Worst Case Simultaneous Transmission Configuration

2.6 Software and Firmware

The test was conducted with firmware version watchOS 8.0 installed on the EUT.

2.7 EMI Suppression Device(s)/Modifications

No EMI suppression device(s) were added and/or no modifications were made during testing.

FCC ID: BCG-A2473 IC: 579C-A2473	 Proud to be part of element	MEASUREMENT REPORT (CERTIFICATION)	Approved by: Quality Manager
Test Report S/N: 1C2106070041-08.BCG	Test Dates: 06/08/2021-08/06/2021	EUT Type: Watch	Page 6 of 63

3.0 DESCRIPTION OF TESTS

3.1 Evaluation Procedure

The measurement procedures described in the American National Standard of Procedures for Compliance Testing of Unlicensed Wireless Devices (ANSI C63.10-2013) and the guidance provided in KDB 393764 D01 v02 were used in the measurement of the EUT.

Deviation from measurement procedure.....None

3.2 AC Line Conducted Emissions

The line-conducted facility is located inside a 7m x 3.66m x 2.7m shielded enclosure. The shielded enclosure is manufactured by AP Americas. The shielding effectiveness of the shielded room is in accordance with MIL-Std-285 or NSA 65-5. A 1m x 1.5m wooden table 80cm high is placed 40cm away from the vertical wall and 80cm away from the sidewall of the shielded room. Two 10kHz-30MHz, 50Ω/50μH Line-Impedance Stabilization Networks (LISNs) are bonded to the shielded room floor. Power to the LISNs is filtered by external high-current high-insertion loss power line filters. The external power line filter is EPCOS 2X60A Power Line Filter (100dB Attenuation, 14kHz-18GHz) and the two EPCOs 2X48A filters (100dB Minimum Insertion Loss, 14kHz – 10GHz). These filters attenuate ambient signal noise from entering the measurement lines. These filters are also bonded to the shielded enclosure.

The EUT is powered from one LISN and the support equipment is powered from the second LISN. If the EUT is a DC-powered device, power will be derived from the source power supply it normally will be powered from and this supply line(s) will be connected to the second LISN. All interconnecting cables more than 1 meter were shortened to a 1 meter length by non-inductive bundling (serpentine fashion) and draped over the back edge of the test table. All cables were at least 40cm above the horizontal reference groundplane. Power cables for support equipment were routed down to the second LISN while ensuring that that cables were not draped over the second LISN.

Sufficient time for the EUT, support equipment, and test equipment was allowed in order for them to warm up to their normal operating condition. The RF output of the LISN was connected to the spectrum analyzer and exploratory measurements were made to determine the frequencies producing the maximum emission from the EUT. The spectrum was scanned from 150kHz to 30MHz with a spectrum analyzer. The detector function was set to peak mode for exploratory measurements while the bandwidth of the analyzer was set to 10kHz. The EUT, support equipment, and interconnecting cables were arranged and manipulated to maximize each emission. Once the worst case emissions have been identified, the one EUT cable configuration/arrangement and mode of operation that produced these emissions is used for final measurements on the same test site. The analyzer is set to CISPR quasi-peak and average detectors with a 9kHz resolution bandwidth for final measurements.

Line conducted emissions test results are shown in Section 7.8. Automated test software was used to perform the AC line conducted emissions testing. Automated measurement software utilized is Rohde & Schwarz EMC32, Version 10.50.40.

FCC ID: BCG-A2473 IC: 579C-A2473	 Proud to be part of element	MEASUREMENT REPORT (CERTIFICATION)	Approved by: Quality Manager
Test Report S/N: 1C2106070041-08.BCG	Test Dates: 06/08/2021-08/06/2021	EUT Type: Watch	Page 7 of 63

3.3 Radiated Emissions

The radiated test facilities consisted of an indoor 3 meter semi-anechoic chamber used for final measurements and exploratory measurements, when necessary. The measurement area is contained within the semi-anechoic chamber which is shielded from any ambient interference. The test site inside the chamber is a 6m x 5.2m elliptical, obstruction-free area in accordance with Figure 5.7 of Clause 5 in ANSI C63.4-2014. Absorbers are arranged on the floor between the turn table and the antenna mast in such a way so as to maximize the reduction of reflections for measurements above 1GHz. An 80cm tall test table made of Styrodur is placed on top of the turn table. For measurements above 1GHz, an additional Styrodur pedestal is placed on top of the test table to bring the total table height to 1.5m.

Per KDB 414788, radiated emission test sites other than open-field test sites (e.g., shielded anechoic chambers), may be employed for emission measurements below 30MHz if characterized so that the measurements correspond to those obtained at an open-field test site. To determine test site equivalency, a reference sample transmitting at 149kHz was measured on an open field test site (asphalt with no ground plane) and then measured in the 3m semi-anechoic chamber. A calibrated 60cm loop antenna was rotated about its vertical axis while the reference device was rotated through the X, Y and Z axis in order to capture the worst case level. A maximum deviation of 2.77dB at 149kHz was measured when comparing the 3 meter semi-anechoic chamber to the open field site.

For all measurements, the spectrum was scanned through all EUT azimuths and from 1 to 4 meter receive antenna height using a broadband antenna from 30MHz up to the upper frequency shown in 15.33 depending on the highest frequency generated or used in the device or on which the device operates or tunes. For frequencies above 1GHz, linearly polarized double ridge horn antennas were used. For frequencies below 30MHz, a calibrated loop antenna was used. When exploratory measurements were necessary, they were performed at 1 meter test distance inside the semi-anechoic chamber using broadband antennas, broadband amplifiers, and spectrum analyzers to determine the frequencies and modes producing the maximum emissions. Sufficient time for the EUT, support equipment, and test equipment was allowed in order for them to warm up to their normal operating condition. The test set-up was placed on top of the 1 x 1.5 meter table. The EUT, support equipment, and interconnecting cables were arranged and manipulated to maximize each emission. Appropriate precaution was taken to ensure that all emissions from the EUT were maximized and investigated. The system configuration, mode of operation, turntable azimuth, and receive antenna height was noted for each frequency found.

Final measurements were made in the semi-anechoic chamber using calibrated, linearly polarized broadband and horn antennas. The test setup was configured to the setup that produced the worst case emissions. The spectrum analyzer was set to investigate all frequencies required for testing to compare the highest radiated disturbances with respect to the specified limits. The turntable containing the EUT was rotated through 360 degrees and the height of the receive antenna was varied 1 to 4 meters and stopped at the azimuth and height producing the maximum emission. Each emission was maximized by changing the orientation of the EUT through three orthogonal planes and changing the polarity of the receive antenna, whichever produced the worst-case emissions.

3.4 Environmental Conditions

The temperature is controlled within range of 15°C to 35°C. The relative humidity is controlled within range of 10% to 75%. The atmospheric pressure is monitored within the range 86-106kPa (860-1060mbar).

FCC ID: BCG-A2473 IC: 579C-A2473		MEASUREMENT REPORT (CERTIFICATION)	Approved by: Quality Manager
Test Report S/N: 1C2106070041-08.BCG	Test Dates: 06/08/2021-08/06/2021	EUT Type: Watch	Page 8 of 63

4.0 ANTENNA REQUIREMENTS

Excerpt from §15.203 of the FCC Rules/Regulations:

“An intentional radiator antenna shall be designed to ensure that no antenna other than that furnished by the responsible party can be used with the device. The use of a permanently attached antenna or of an antenna that uses a unique coupling to the intentional radiator shall be considered sufficient to comply with the provisions of this section.”

- The antenna(s) of the EUT are **permanently attached**.
- There are no provisions for connection to an external antenna.

Conclusion:

The EUT complies with the requirement of §15.203.

FCC ID: BCG-A2473 IC: 579C-A2473		MEASUREMENT REPORT (CERTIFICATION)	Approved by: Quality Manager
Test Report S/N: 1C2106070041-08.BCG	Test Dates: 06/08/2021-08/06/2021	EUT Type: Watch	Page 9 of 63

5.0 MEASUREMENT UNCERTAINTY

The measurement uncertainties shown below were calculated in accordance with the requirements of ANSI C63.23-2012. All measurement uncertainty values are shown with a coverage factor of $k = 2$ to indicate a 95% level of confidence. The measurement uncertainty shown below meets or exceeds the U_{CISPR} measurement uncertainty values specified in CISPR 16-4-2 and, thus, can be compared directly to specified limits to determine compliance.

Contribution	Expanded Uncertainty (\pm dB)
Conducted Bench Top Measurements	1.65
Line Conducted Disturbance	2.75
Radiated Disturbance (<30MHz)	4.06
Radiated Disturbance (<1GHz)	4.30
Radiated Disturbance (>1GHz)	4.78
Radiated Disturbance (>18GHz)	4.79

Parameter	Expanded Uncertainty
Time	$\pm 0.02\%$

FCC ID: BCG-A2473 IC: 579C-A2473	 PCTEST Proud to be part of  element	MEASUREMENT REPORT (CERTIFICATION)	Approved by: Quality Manager
Test Report S/N: 1C2106070041-08.BCG	Test Dates: 06/08/2021-08/06/2021	EUT Type: Watch	Page 10 of 63

6.0 TEST EQUIPMENT CALIBRATION DATA

Test Equipment Calibration is traceable to the National Institute of Standards and Technology (NIST). Measurements antennas used during testing were calibrated in accordance to the requirements of ANSI C63.5-2017.

Manufacturer	Model	Description	Cal Date	Cal Interval	Cal Due	Serial Number
Agilent Technologies	N9030A	3Hz-44GHz PXA Signal Analyzer	3/31/2021	Annual	3/31/2022	MY49430244
ATM	180-442-KF	20dB Nominal Gain Horn Antenna	12/9/2020	Annual	12/9/2021	T058701-01
ETS-Lindgren	3142E	BiConiLog Antenna (30MHz - 6GHz)	9/15/2020	Annual	9/15/2021	208204
ETS-Lindgren	3117	Double Ridged Guide Antenna (1-18 GHz)	5/3/2021	Annual	5/3/2022	205956
Keysight Technology	N9040B	UXA Signal Analyzer	12/19/2020	Annual	12/19/2021	MY57212015
Rohde & Schwarz	TS-PR8	Pre-Amplifier (30MHz - 8GHz)	12/3/2020	Annual	12/3/2021	102327
Rohde & Schwarz	TS-PR18	Pre-Amplifier (1GHz - 18GHz)	12/3/2020	Annual	12/3/2021	101648
Rohde & Schwarz	FSV40	Signal Analyzer (10Hz-40GHz)	3/16/2021	Annual	3/16/2022	101619
Rohde & Schwarz	ESW26	EMI Test Receiver	6/11/2021	Annual	6/11/2022	101299
Rohde & Schwarz	ESW44	EMI Test Receiver	11/9/2020	Annual	11/9/2021	101570
Rohde & Schwarz	TS-PR1840	Pre-Amplifier (18GHz - 40GHz)	4/29/2021	Annual	4/29/2022	100051
Rohde & Schwarz	TC-TA18	Cross Polarized Vivaldi Antenna (400MHz-18GHz)	10/2/2020	Annual	10/2/2021	101063
Rohde & Schwarz	HFH2-Z2	Loop Antenna	4/5/2021	Annual	4/5/2022	100519
Rohde & Schwarz	ENV216	Two-Line-V-Network (LSN)	12/7/2020	Annual	12/7/2021	101364

Table 6-1. Test Equipment List

Note:

For equipment listed above that has a calibration date or calibration due date that falls within the test date range, care was taken to ensure that this equipment was used after the calibration date and before the calibration due date.

FCC ID: BCG-A2473 IC: 579C-A2473		MEASUREMENT REPORT (CERTIFICATION)	Approved by: Quality Manager
Test Report S/N: 1C2106070041-08.BCG	Test Dates: 06/08/2021-08/06/2021	EUT Type: Watch	Page 11 of 63

7.0 TEST RESULTS

7.1 Summary

Company Name: Apple Inc.
 FCC ID: BCG-A2473
 IC: 579C-A2473
 FCC Classification: Ultra-Wideband Transmitter

FCC Part Section(s)	RSS Section(s)	Test Description	Test Limit	Test Condition	Test Result	Reference
§15.503, §15.519 (b)	RSS-220 [2]	10dBc Bandwidth	≥ 500MHz	RADIATED	PASS	Section 7.2, 7.3
§ 2.1049	RSS-Gen [6.7]	Occupied Bandwidth	N/A		N/A	Section 7.3
§15.519 (e)	RSS-220 [5.3.1(g)]	Maximum Peak Power Spectral Density (Peak EIRP)	< 0 dBm/50MHz EIRP		PASS	Sections 7.4.1
§15.519 (c)	RSS-220 [5.3.1(d)]	Maximum Average Emission (Average EIRP)	< -41.3 dBm/MHz EIRP		PASS	Section 7.4.2
§15.519 (a)(1)	RSS-220 [5.3.1(b)]	Cease Transmission Time	See §15.519 (a)(1) and RSS-220 [5.3.1(b)] for details		PASS	Section 7.5
§15.519 (c)	RSS-220 [5.3.1(d)]	Radiated Emissions Above 960MHz	See §15.519 (c) and RSS-220 [5.3.1(d)] for details		PASS	Sections 7.6
§15.519 (d)	RSS-220 [5.3.1(e)]	Radiated Emissions in the 1164 – 1240Mhz and 1559 – 1610MHz GPS Bands	See §15.519 (d) and RSS-220 [5.3.1(e)] for details		PASS	Sections 7.6
§15.519 (c), §15.209	RSS-220 [3.4] RSS-Gen [8.9]	Radiate Emissions Below 960MHz	Emissions in restricted bands must meet the radiated limits detailed in §15.209 (RSS-Gen [8.9])		PASS	Sections 7.7
§15.207	RSS-Gen [8.8]	AC Line Conducted Emissions 150kHz – 30MHz	< FCC 15.207 limits (RSS-Gen [8.8])	AC LINE CONDUCTED	PASS	Section 7.8

Table 7-1. Summary of Test Results

Notes:

- All modes of operation were investigated. The test results shown in the following sections represent the worst case emissions.
- The analyzer plots shown in this section were all taken with a correction table loaded into the analyzer. The correction table was used to account for the losses of the cables and attenuators used as part of the system to connect the EUT to the analyzer at all frequencies of interest.

FCC ID: BCG-A2473 IC: 579C-A2473		MEASUREMENT REPORT (CERTIFICATION)	Approved by: Quality Manager
Test Report S/N: 1C2106070041-08.BCG	Test Dates: 06/08/2021-08/06/2021	EUT Type: Watch	Page 12 of 63

7.2 10dBc Bandwidth Measurement

§15.503 §15.519 (b)

Test Overview and Limit

The UWB bandwidth is the frequency band bounded by the points that are 10 dB below the highest radiated emission, as based on the complete transmission system including the antenna. The upper boundary is designated F_H and the lower boundary is designated F_L . The frequency at which the highest radiated emission occurs is designated F_M .

- The center frequency, F_c , equals $(F_H + F_L)/2$
- The fractional bandwidth equals $2(F_H - F_L) / (F_H + F_L)$

The UWB bandwidth of a device operating under the provisions of this section must be contained between 3100MHz and 10,600MHz.

- a) *The minimum permissible 10dBc Bandwidth is 500 MHz*
- b) *Fractional bandwidth is equal or greater than 0.20*

Test Procedure Used

ANSI C63.10-2013 – Section 10.1
KDB 393764 D01 v02

Test Settings

1. RBW = 1MHz
2. VBW = 3MHz
3. Detector = Peak
4. Trace mode = max hold
5. Sweep = auto couple
6. The trace was allowed to stabilize

FCC ID: BCG-A2473 IC: 579C-A2473		MEASUREMENT REPORT (CERTIFICATION)	Approved by: Quality Manager
Test Report S/N: 1C2106070041-08.BCG	Test Dates: 06/08/2021-08/06/2021	EUT Type: Watch	Page 13 of 63

Test Setup

The EUT and measurement equipment were set up as shown in the diagram below.

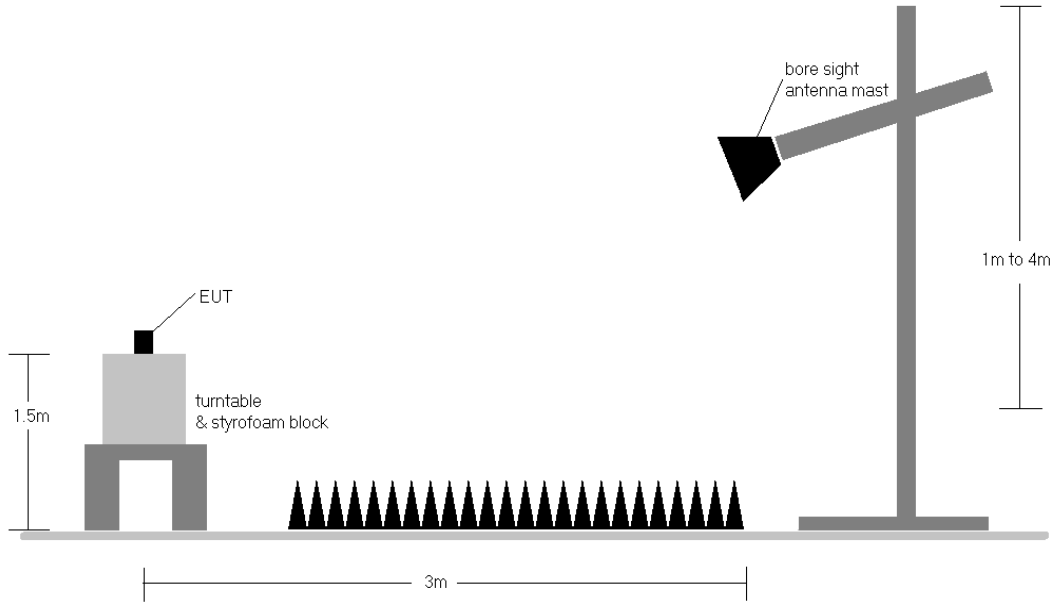

Figure 7-1. Test Setup

Test Notes

1. In those cases where the measured emission spectrum contains multiple (more than two) -10dBc points, the outermost points define the UWB bandwidth (i.e., the widest bandwidth is reported).
2. All modes of operation were investigated and the worst-case emissions are reported.

FCC ID: BCG-A2473 IC: 579C-A2473	PCTEST Proud to be part of element	MEASUREMENT REPORT (CERTIFICATION)	Approved by: Quality Manager
Test Report S/N: 1C2106070041-08.BCG	Test Dates: 06/08/2021-08/06/2021	EUT Type: Watch	Page 14 of 63

Frequency [GHz]	Channel	Config	Payload	F _M [GHz]	F _L [GHz]	F _H [GHz]	F _C [GHz]	Measured Bandwidth [MHz]	Minimum Bandwidth [MHz]	Pass / Fail
6.5	5	3	125	6.250	6.229	6.751	6.490	522.1	500	Pass

Table 7-2. 10dBc Bandwidth Measurements (UWB, Ch.5, 6.5GHz)

Table 7-3. 10dBc Bandwidth M

Frequency [GHz]	Channel	Config	Payload	F _M [GHz]	F _L [GHz]	F _H [GHz]	F _C [GHz]	Measured Bandwidth [MHz]	Minimum Bandwidth [MHz]	Pass / Fail
8	9	3	125	8.226	7.726	8.248	7.987	522.7	500	Pass

Measurements (UWB, Ch.9, 8GHz)

FCC ID: BCG-A2473 IC: 579C-A2473		MEASUREMENT REPORT (CERTIFICATION)	Approved by: Quality Manager
Test Report S/N: 1C2106070041-08.BCG	Test Dates: 06/08/2021-08/06/2021	EUT Type: Watch	Page 15 of 63

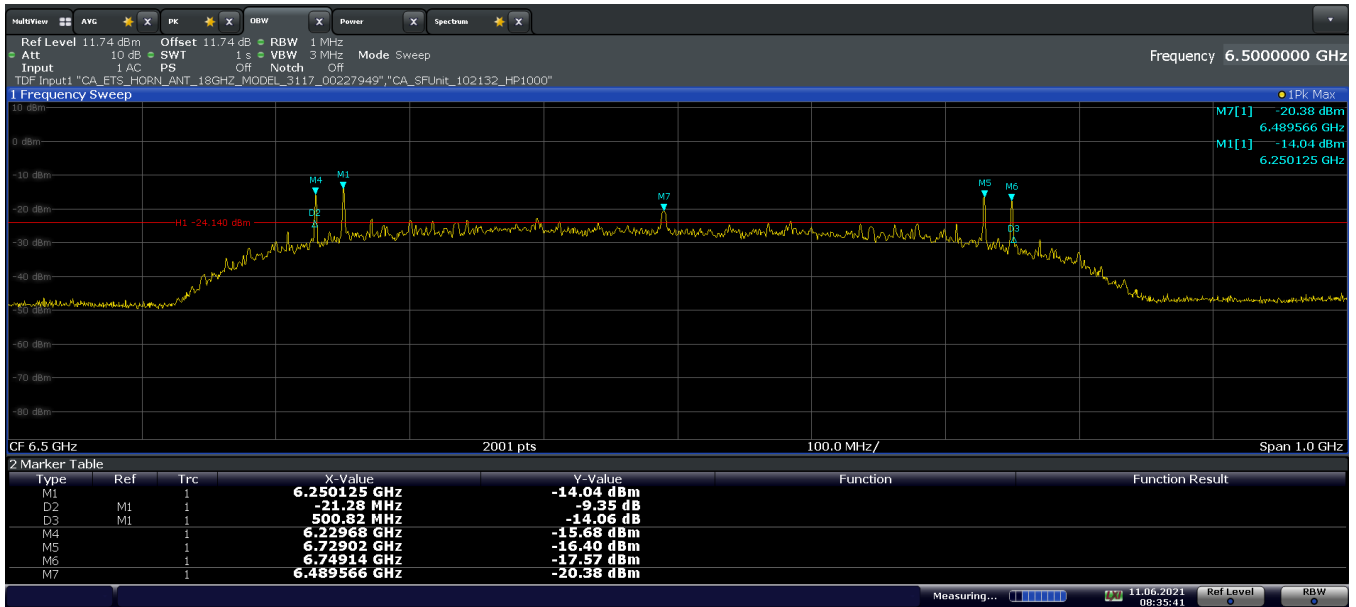

08:35:41 11.06.2021

Plot 7-1. 10dBc Bandwidth (Ch. 5, Config 3/Payload 125)

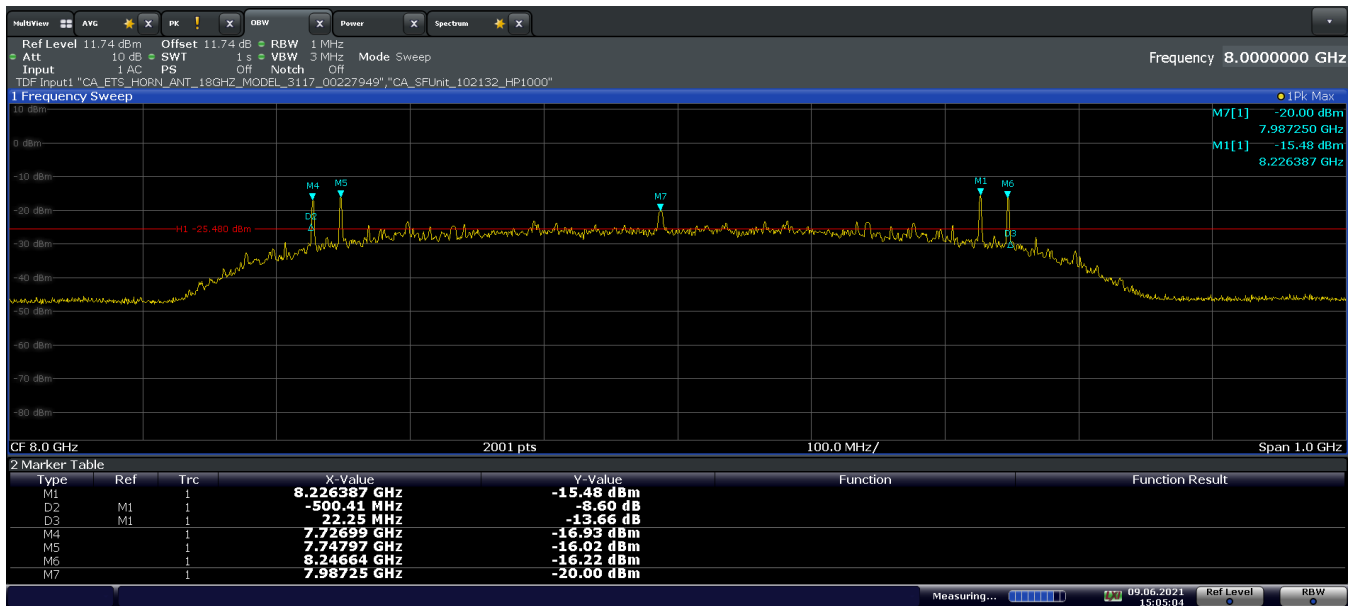

15:05:05 09.06.2021

Plot 7-2. 10dBc Bandwidth (Ch. 9, Config 3/Payload 125)

FCC ID: BCG-A2473 IC: 579C-A2473		MEASUREMENT REPORT (CERTIFICATION)	Approved by: Quality Manager
Test Report S/N: 1C2106070041-08.BCG	Test Dates: 06/08/2021-08/06/2021	EUT Type: Watch	Page 16 of 63

7.3 Bandwidth Measurement

RSS-220 [2], RSS-Gen [6.7]

Test Overview

The occupied bandwidth, that is the frequency bandwidth such that, below its lower and above its upper frequency limits, the mean powers radiated are each equal to 0.5 percent of the total mean power radiated by a given emission shall be measured. All modes of operation were investigated and the worst case configuration results are reported in this section.

Test Procedure Used

ANSI C63.10-2013 – Section 6.9
RSS-Gen [6.7]

Test Settings

1. The signal analyzer’s automatic bandwidth measurement capability was used to perform the 99% occupied bandwidth and the 10dB bandwidth. The bandwidth measurement was not influenced by any intermediate power nulls in the fundamental emission.
2. RBW = 1 – 5% of the expected OBW
3. VBW ≥ 3 x RBW
4. Detector = Peak
5. Trace mode = max hold
6. Sweep = auto couple
7. The trace was allowed to stabilize
8. If necessary, steps 2 – 7 were repeated after changing the RBW such that it would be within 1 – 5% of the 99% occupied bandwidth observed in Step 7

Test Setup

The EUT and measurement equipment were set up as shown in the diagram below.

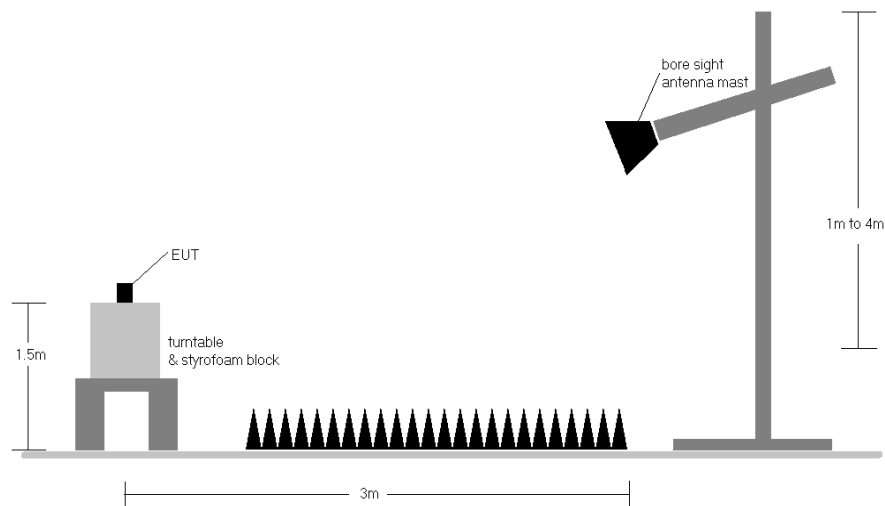

Figure 7-2. Test Setup

FCC ID: BCG-A2473 IC: 579C-A2473	 PCTEST® Proud to be part of element	MEASUREMENT REPORT (CERTIFICATION)	Approved by: Quality Manager
Test Report S/N: 1C2106070041-08.BCG	Test Dates: 06/08/2021-08/06/2021	EUT Type: Watch	Page 17 of 63

Frequency [GHz]	Channel	Config	Payload	Measured OBW [MHz]	Measured 10dBc Bandwidth [MHz]	Minimum Bandwidth [MHz]	Pass / Fail
6.5	5	3	125	624.62	517.60	500	Pass

Table 7-4. ISED 10dBc Bandwidth & 99% OBW Measurements (UWB, Ch.5, 6.5GHz)

Frequency [GHz]	Channel	Config	Payload	Measured OBW [MHz]	Measured 10dBc Bandwidth [MHz]	Minimum Bandwidth [MHz]	Pass / Fail
8	9	3	125	650.42	530.20	500	Pass

Table 7-5. ISED 10dBc Bandwidth & 99% OBW Measurements (UWB, Ch.9, 8GHz)

FCC ID: BCG-A2473 IC: 579C-A2473	 PCTEST Proud to be part of 	MEASUREMENT REPORT (CERTIFICATION)	Approved by: Quality Manager
Test Report S/N: 1C2106070041-08.BCG	Test Dates: 06/08/2021-08/06/2021	EUT Type: Watch	Page 18 of 63



Plot 7-3. ISED 10dBc Bandwidth & 99% OBW (Ch. 5, Config 3/Payload 125)

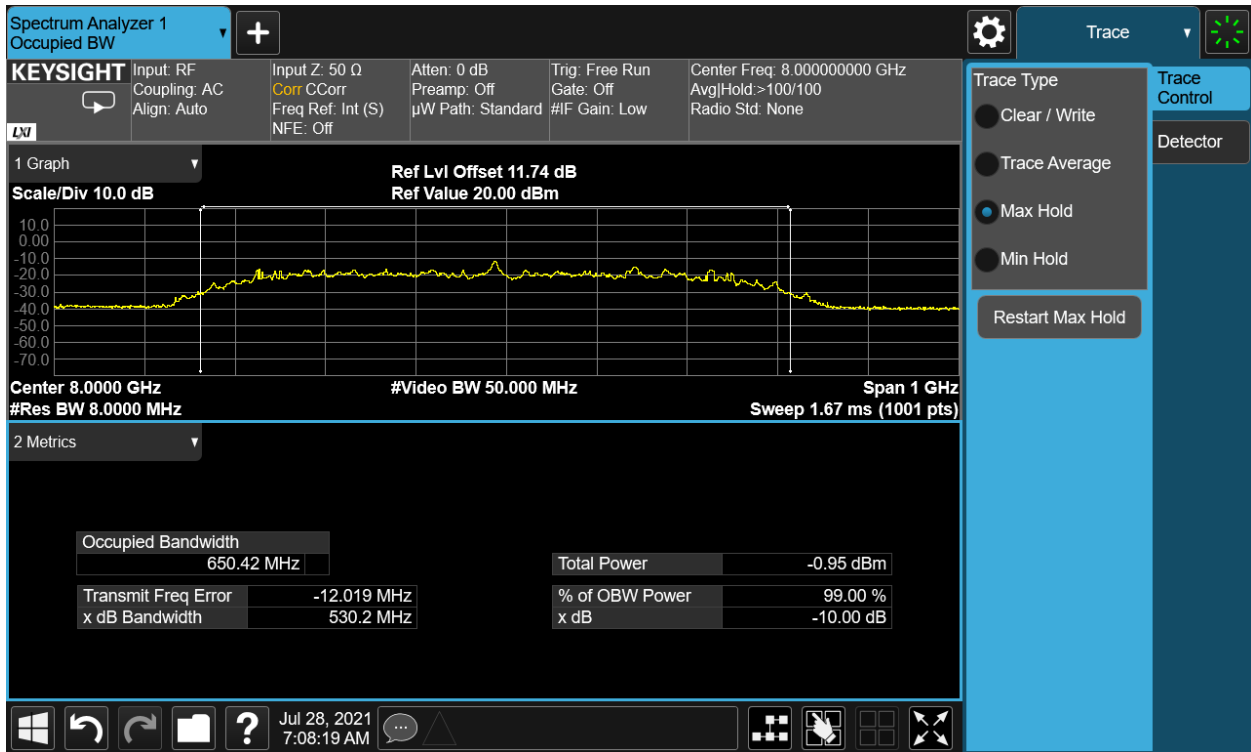

Plot 7-4. ISED 10dBc Bandwidth & 99% OBW (Ch. 9, Config 3/Payload 125)

FCC ID: BCG-A2473 IC: 579C-A2473	 MEASUREMENT REPORT (CERTIFICATION)	Approved by: Quality Manager
Test Report S/N: 1C2106070041-08.BCG	Test Dates: 06/08/2021-08/06/2021	EUT Type: Watch
		Page 19 of 63

7.4 Maximum Peak and Average Radiated Power (EIRP) §15.519 (c) §15.519 (e); RSS-220 [5.3.1(d)] RSS-220 [5.3.1(g)]

Test Overview and Limits

15.519 (e) There is a limit on the peak level of the emissions contained within a 50 MHz bandwidth centered on the frequency at which the highest radiated emission occurs, F_M . That limit is 0 dBm for Peak EIRP.

15.519 (c) The radiated emissions above 960 MHz from a device operating under the provisions of this section shall not exceed the following average limits when measured using a resolution bandwidth of 1 MHz:

Frequency [MHz]	EIRP [dBm]
3100-10600	-41.3

Table 7-6. FCC 15.519 Average EIRP limit

Frequency [MHz]	EIRP [dBm]
4750-10600	-41.3

Table 7-7. RSS-220 Average EIRP limit

Test Procedure Used

ANSI C63.10-2013 – Section 10.3.5 and 10.3.7
KDB 393764 D01 v02

Test Settings

Average EIRP Measurements

1. RBW = 1MHz
2. VBW = 3MHz
3. Detector = Average (RMS)
4. Sweep time = No more than a 1 ms integration period over each measurement bin
5. Trace mode = Max hold
6. Trace was allowed to stabilize

Peak EIRP Measurements

1. RBW = 50MHz
2. VBW = 50MHz
3. Detector = Peak
4. Sweep time = auto couple
5. Trace mode = Max hold
6. Trace was allowed to stabilize

FCC ID: BCG-A2473 IC: 579C-A2473	 PCTEST® Proud to be part of element	MEASUREMENT REPORT (CERTIFICATION)	Approved by: Quality Manager
Test Report S/N: 1C2106070041-08.BCG	Test Dates: 06/08/2021-08/06/2021	EUT Type: Watch	Page 20 of 63

Test Setup

The EUT and measurement equipment were set up as shown in the diagram below.

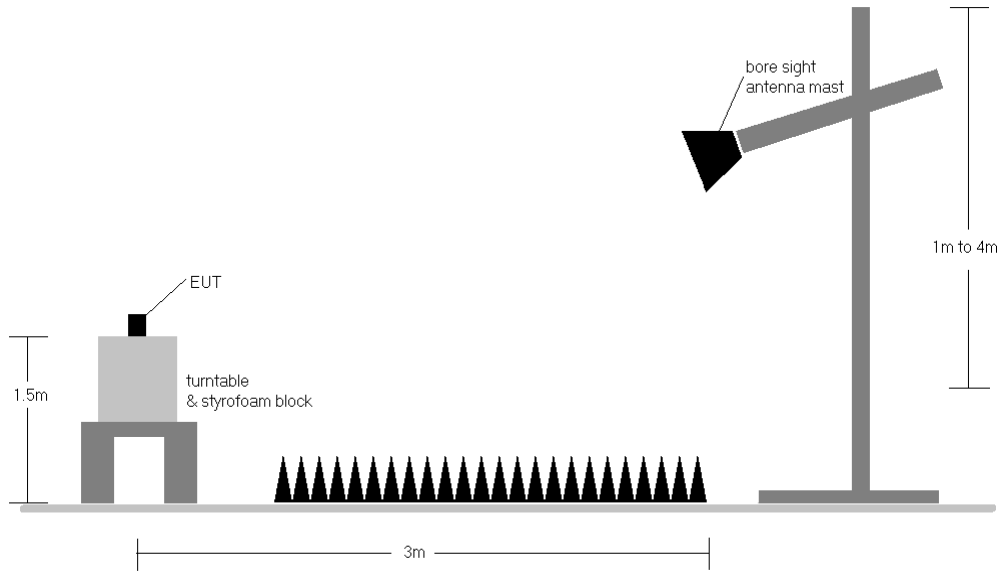

Figure 7-3. Test Setup

Test Notes

1. The antenna is manipulated through typical positions, polarity and length during the tests. The EUT is manipulated through three orthogonal planes.
2. All modes of operation were investigated and the worst-case emissions are reported.

FCC ID: BCG-A2473 IC: 579C-A2473		MEASUREMENT REPORT (CERTIFICATION)	Approved by: Quality Manager
Test Report S/N: 1C2106070041-08.BCG	Test Dates: 06/08/2021-08/06/2021	EUT Type: Watch	Page 21 of 63

7.4.1 Peak Radiated Power Measurement

§15.519 (e); RSS-220 [5.3.1(g)]

Frequency [GHz]	Channel	Config	Payload	Ant. Pol. [H/V]	Ant. Height [cm]	Turntable Azimuth [degree]	F _M [GHz]	Peak EIRP [dBm/50MHz]	Peak EIRP Limit [dBm/50MHz]	Margin [dB]
6.5	5	3	125	H	102	120	6.4883	-6.95	0.00	-6.95

Table 7-8. Peak EIRP Measurements (UWB Ch. 5, 6.5GHz)

Frequency [GHz]	Channel	Config	Payload	Ant. Pol. [H/V]	Ant. Height [cm]	Turntable Azimuth [degree]	F _M [GHz]	Peak EIRP [dBm/50MHz]	Peak EIRP Limit [dBm/50MHz]	Margin [dB]
8.0	9	3	125	V	326	92	7.9998	-4.81	0.00	-4.81

Table 7-9. Peak EIRP Measurements (UWB Ch. 9, 8GHz)

FCC ID: BCG-A2473 IC: 579C-A2473	 PCTEST Proud to be part of element	MEASUREMENT REPORT (CERTIFICATION)	Approved by: Quality Manager
Test Report S/N: 1C2106070041-08.BCG	Test Dates: 06/08/2021-08/06/2021	EUT Type: Watch	Page 22 of 63

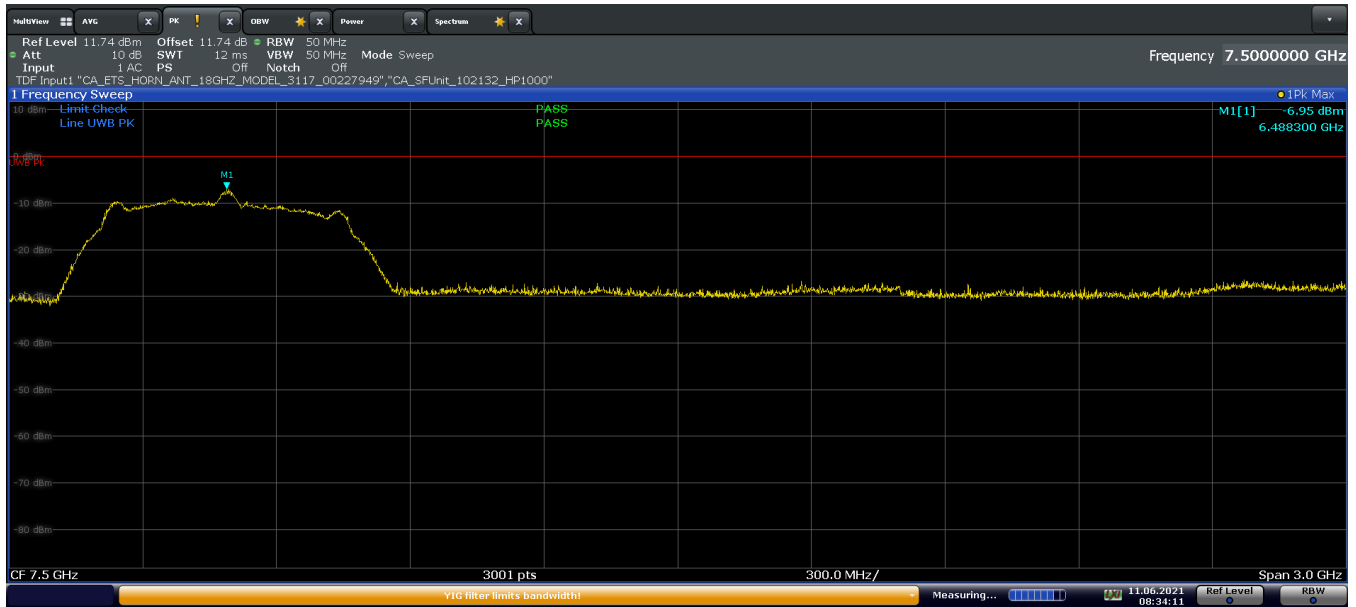

08:34:12 11.06.2021

Plot 7-5. Peak Radiated Power (Ch. 5, Config 3/Payload 125)

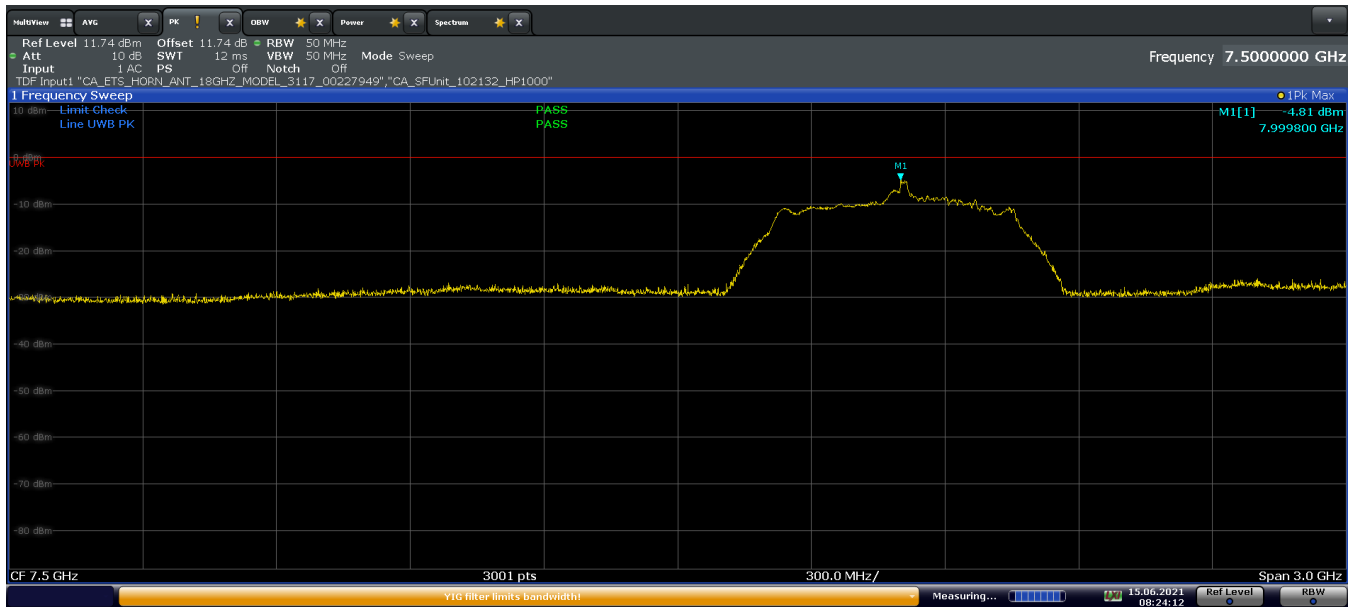

08:24:12 15.06.2021

Plot 7-6. Peak Radiated Power (Ch. 9, Config 3/Payload 125)

FCC ID: BCG-A2473 IC: 579C-A2473	 PCTEST Proud to be part of 	MEASUREMENT REPORT (CERTIFICATION)	Approved by: Quality Manager
Test Report S/N: 1C2106070041-08.BCG	Test Dates: 06/08/2021-08/06/2021	EUT Type: Watch	Page 23 of 63

7.4.2 Average Radiated Power Measurement

§15.519 (c); RSS-220 [5.3.1(d)]

Frequency [GHz]	Channel	Config	Payload	Ant. Pol. [H/V]	Ant. Height [cm]	Turntable Azimuth [degree]	F _M [GHz]	Avg EIRP [dBm/MHz]	Avg EIRP Limit [dBm/MHz]	Margin [dB]
6.5	5	3	125	H	102	120	6.3724	-42.02	-41.30	-0.72

Table 7-10. Average EIRP Measurements (UWB Ch. 5, 6.5GHz)

Frequency [GHz]	Channel	Config	Payload	Ant. Pol. [H/V]	Ant. Height [cm]	Turntable Azimuth [degree]	F _M [GHz]	Avg EIRP [dBm/MHz]	Avg EIRP Limit [dBm/MHz]	Margin [dB]
8.0	9	3	125	V	326	92	8.0248	-42.26	-41.30	-0.96

Table 7-11. Average EIRP Measurements (UWB Ch.9, 8GHz)

FCC ID: BCG-A2473 IC: 579C-A2473		MEASUREMENT REPORT (CERTIFICATION)	Approved by: Quality Manager
Test Report S/N: 1C2106070041-08.BCG	Test Dates: 06/08/2021-08/06/2021	EUT Type: Watch	Page 24 of 63

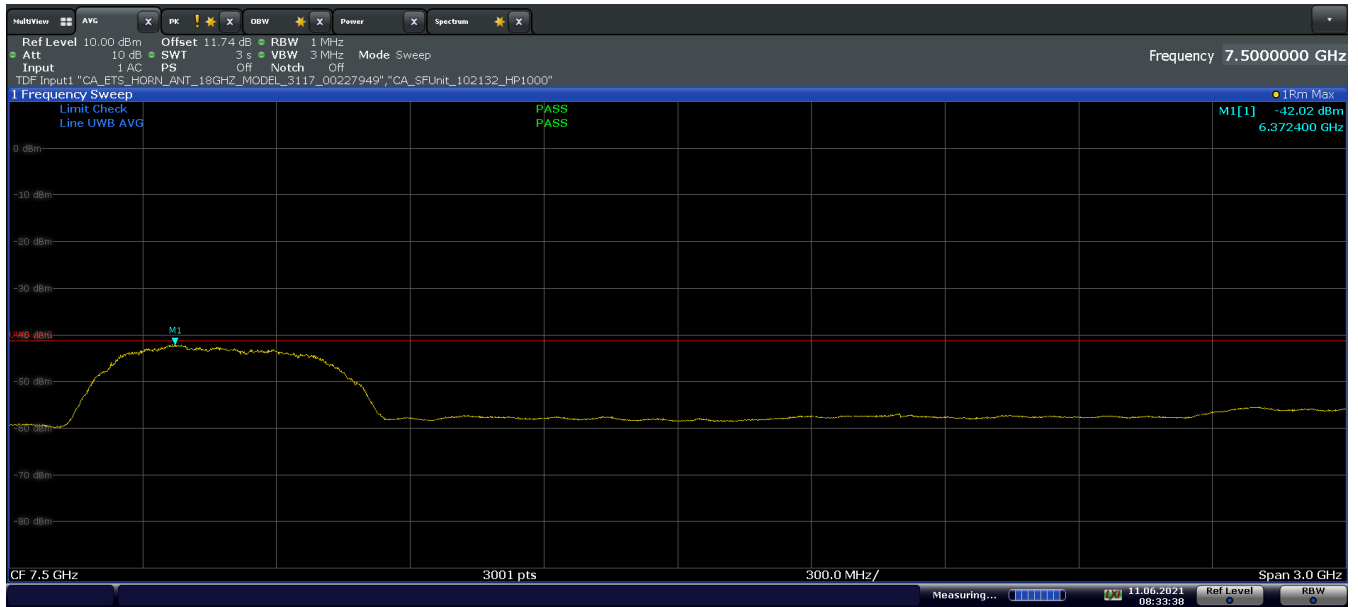

08:33:39 11.06.2021

Plot 7-7. Average Radiated Power (Ch. 5, Config 3/Payload 125)

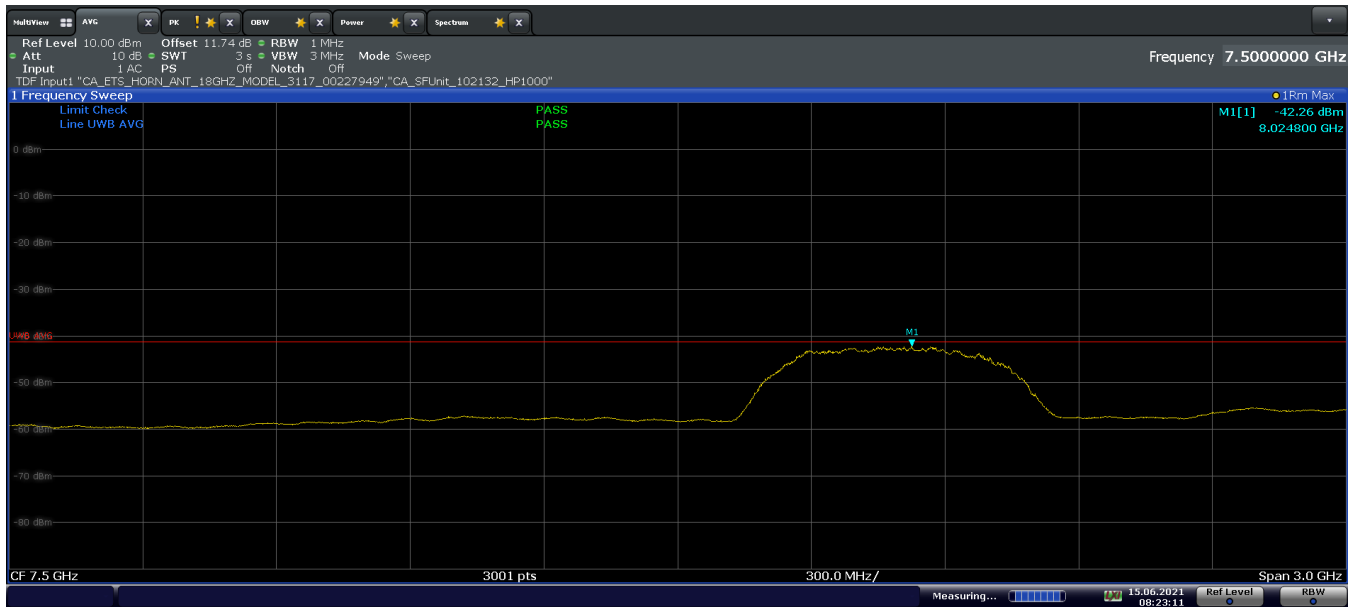

08:23:12 15.06.2021

Plot 7-8. Average Radiated Power (Ch. 9, Config 3/Payload 125)

FCC ID: BCG-A2473 IC: 579C-A2473		MEASUREMENT REPORT (CERTIFICATION)	Approved by: Quality Manager
Test Report S/N: 1C2106070041-08.BCG	Test Dates: 06/08/2021-08/06/2021	EUT Type: Watch	Page 25 of 63

7.5 Cease Transmission Time

§15.519 (a)(1); RSS-220 [5.3.1(b)]

Test Overview and Limit

A UWB device operating under the provisions of this section shall transmit only when it is sending information to an associated receiver. The UWB intentional radiator shall cease transmission within 10 seconds unless it receives an acknowledgement from the associated receiver that its transmission is being received. An acknowledgment of reception must continue to be received by the UWB intentional radiator at least every 10 seconds or the UWB device must cease transmitting.

Test Procedures Used

KDB 393764 D01 v02

Test Settings

1. RBW = 1MHz
2. VBW = 3MHz
3. Span = Zero Span Mode
4. Sweep time shall be sufficient to demonstrate EUTs compliance with the rule part.

Test Setup

The EUT and measurement equipment were set up as shown in the diagram below.

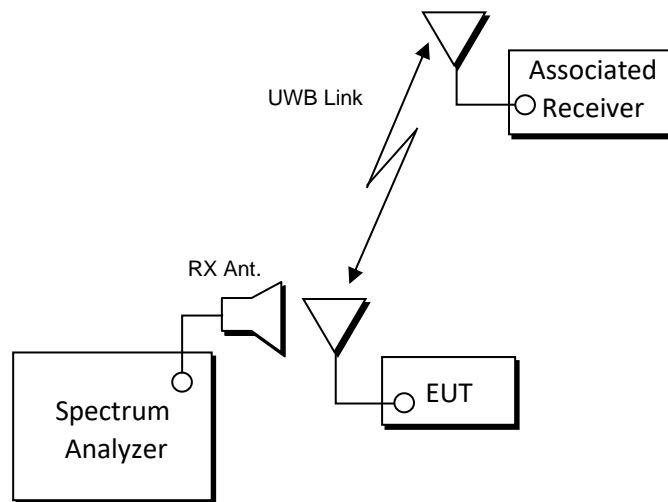

Figure 7-4. Test Setup

FCC ID: BCG-A2473 IC: 579C-A2473	 Proud to be part of element	MEASUREMENT REPORT (CERTIFICATION)	Approved by: Quality Manager
Test Report S/N: 1C2106070041-08.BCG	Test Dates: 06/08/2021-08/06/2021	EUT Type: Watch	Page 26 of 63

Test Configurations

The EUT was monitored in 2 different test configurations:

- Mode 1: EUT initiates the UWB link to the associated receiver (phone),
 - Associated receiver ends the link, and EUT ceases transmission of any information other than periodic signals (polling) for use in the establishment or re-establishment of a communications link with an associated receiver
- Mode 2: The associated receiver (phone) initiates the UWB link to the EUT
 - EUT ends the link, and stops sending acknowledgements to associated receiver

Result

Parameter	Limit	Result
Cessation Time - Mode1	1) The UWB intentional radiator shall cease transmission within 10 seconds 2) An acknowledgment of reception must continue to be received by the UWB intentional radiator at least every 10 seconds or the UWB device must cease transmitting.	Pass
Cessation Time - Mode2	1) The UWB intentional radiator shall cease transmission within 10 seconds 2) An acknowledgment of reception must continue to be received by the UWB intentional radiator at least every 10 seconds or the UWB device must cease transmitting.	Pass

Plots Description

- Cessation Time - Mode1 (Mode2) plot:
 - Marker 1 shows start time of initiating UWB link
 - Marker 2 shows stop time of sending acknowledgement
- Zoom in Cessation Time - Mode1 plot:
 - Marker 1 shows EUT traffic level
 - Marker 2 shows Associated receiver (Phone) traffic level
 - Marker 3 shows Associated receiver (Phone) Acknowledgement signal
 - Marker 4 shows EUT Polling signal (Before ceasing transmission)
 - Marker 5 shows EUT Polling signal (After ceasing transmission)

FCC ID: BCG-A2473 IC: 579C-A2473	 PCTEST [®] Proud to be part of element	MEASUREMENT REPORT (CERTIFICATION)	Approved by: Quality Manager
Test Report S/N: 1C2106070041-08.BCG	Test Dates: 06/08/2021-08/06/2021	EUT Type: Watch	Page 27 of 63

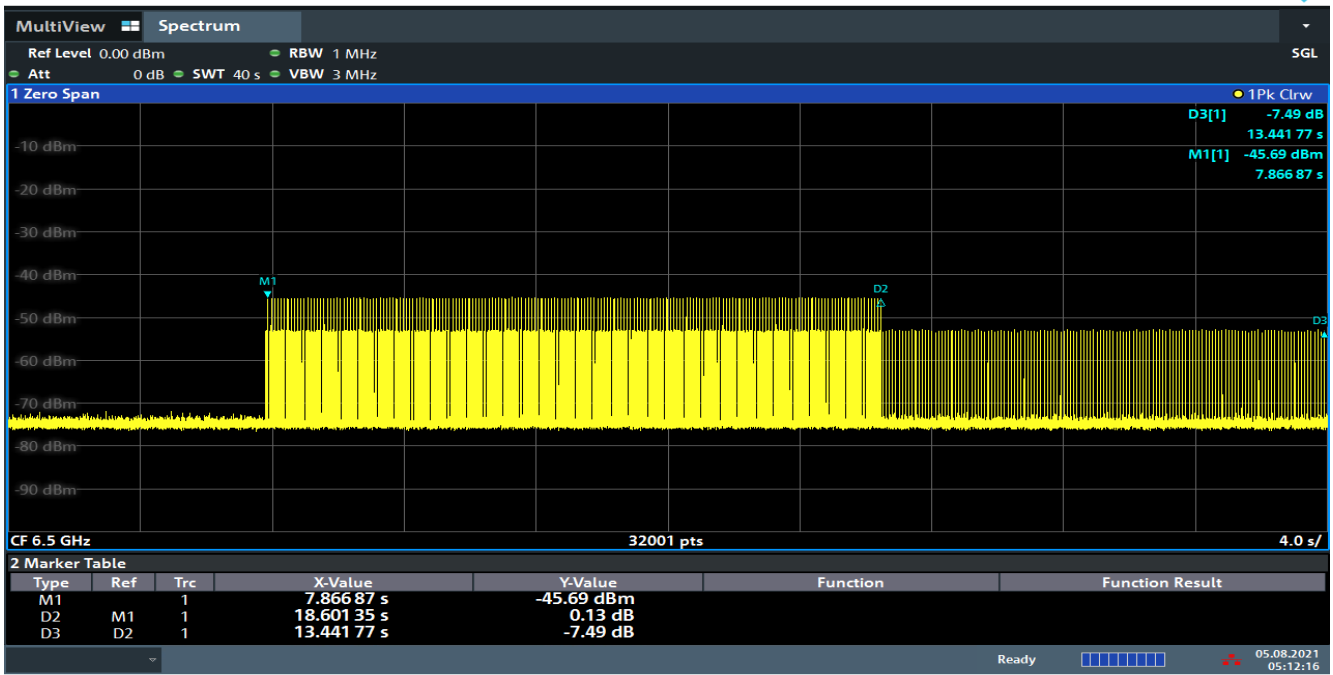

05:12:16 05.08.2021

Plot 7-9. Cessation Time – Mode1 (Ch. 5, 6.5 GHz)

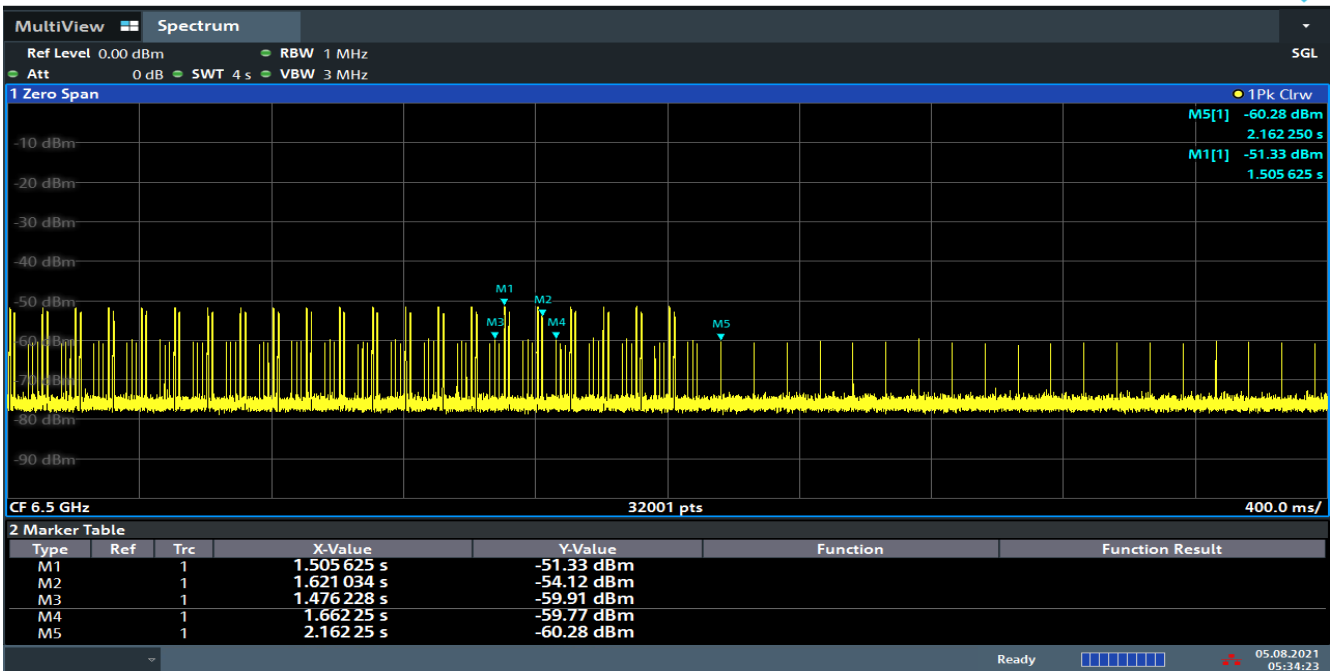

05:34:23 05.08.2021

Plot 7-10. Zoom in Cessation Time – Mode1 (Ch. 5, 6.5 GHz)

FCC ID: BCG-A2473 IC: 579C-A2473	PCTEST Proud to be part of element	MEASUREMENT REPORT (CERTIFICATION)	Approved by: Quality Manager
Test Report S/N: 1C2106070041-08.BCG	Test Dates: 06/08/2021-08/06/2021	EUT Type: Watch	Page 28 of 63

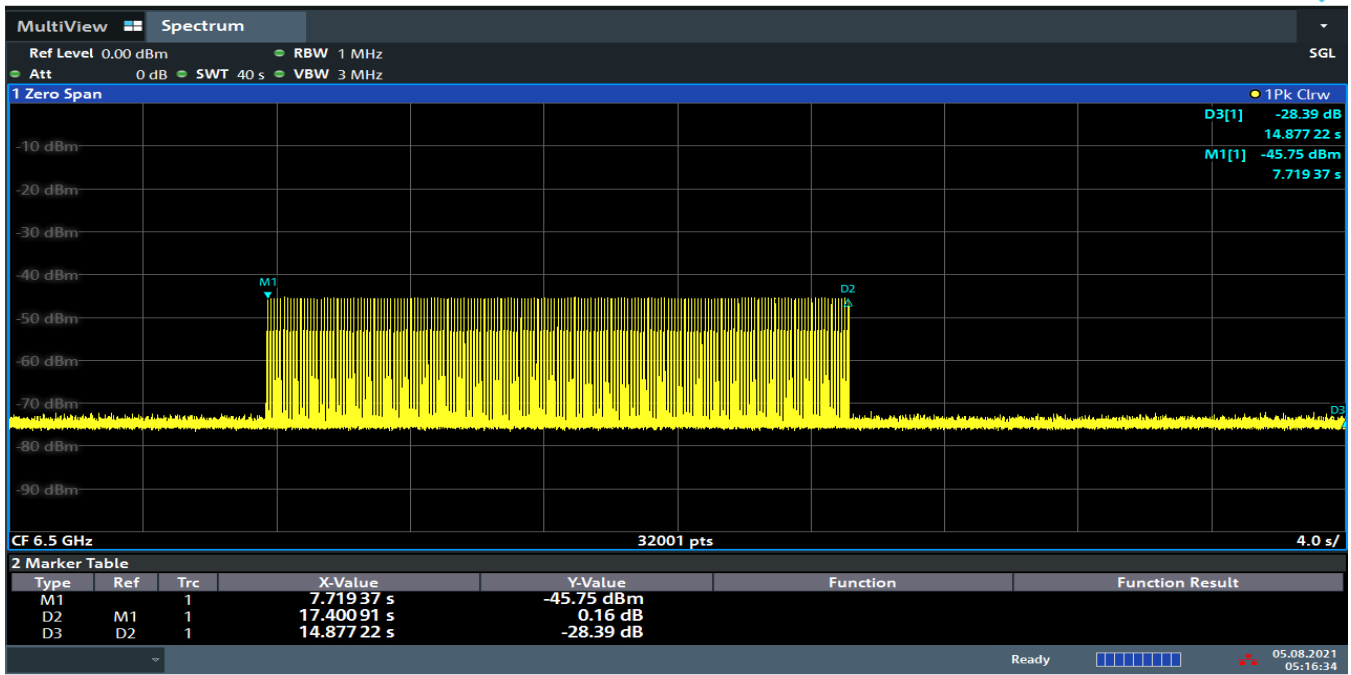

05:16:34 05.08.2021

Plot 7-11. Cessation Time – Mode2 (Ch. 5, 6.5 GHz)

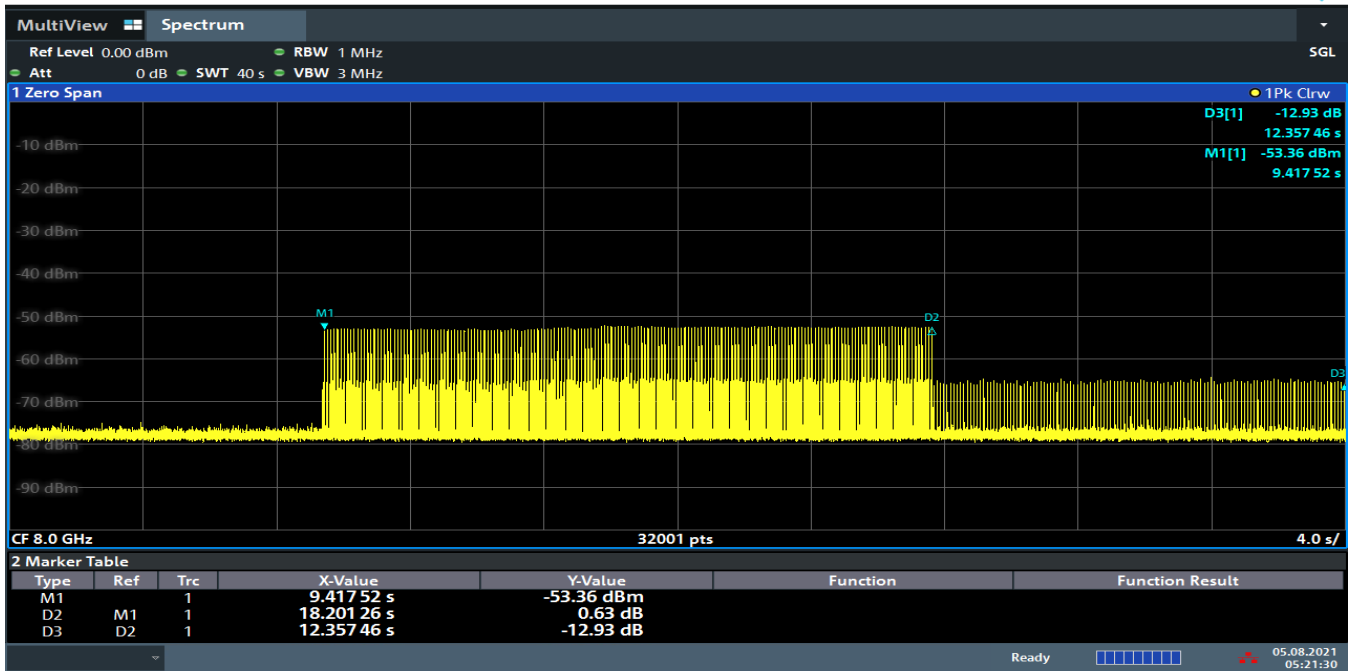

05:21:31 05.08.2021

Plot 7-12. Cessation Time – Mode1 (Ch. 9, 8 GHz)

FCC ID: BCG-A2473 IC: 579C-A2473	PCTEST Proud to be part of element	MEASUREMENT REPORT (CERTIFICATION)	Approved by: Quality Manager
Test Report S/N: 1C2106070041-08.BCG	Test Dates: 06/08/2021-08/06/2021	EUT Type: Watch	Page 29 of 63

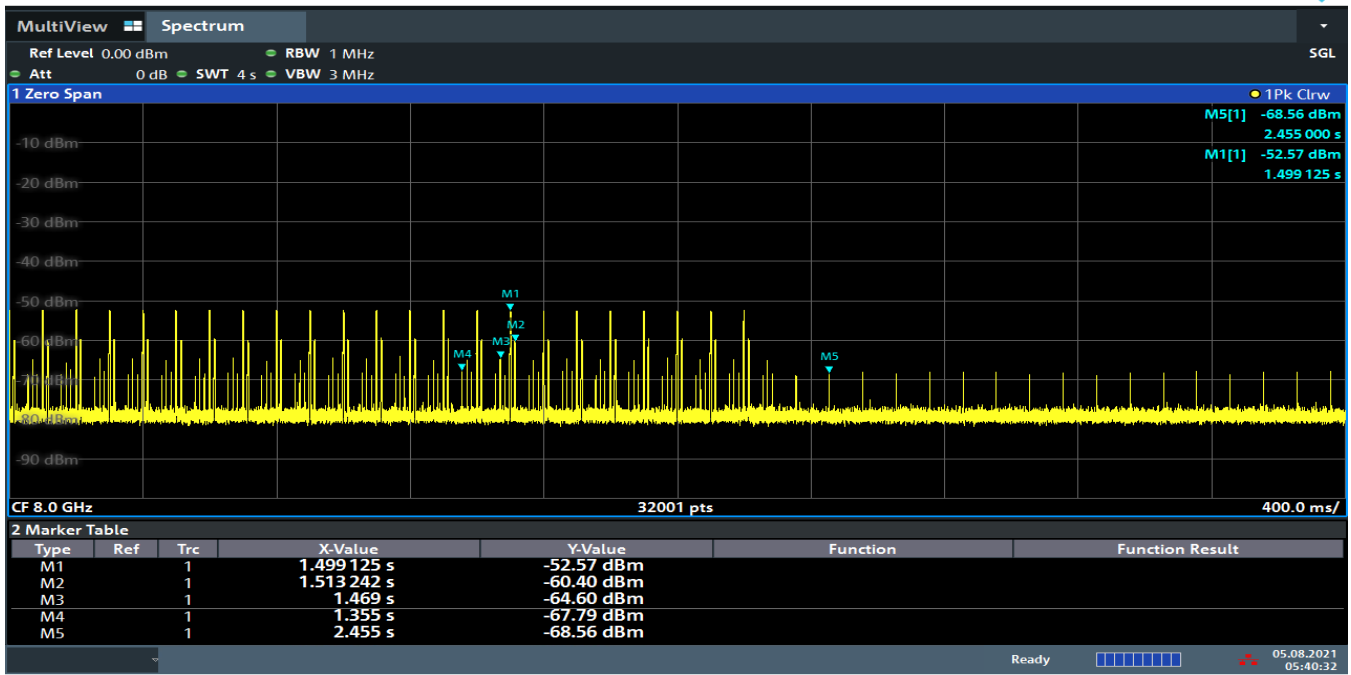

05:40:33 05.08.2021

Plot 7-13. Zoom in Cessation Time – Mode1 (Ch. 9, 8 GHz)

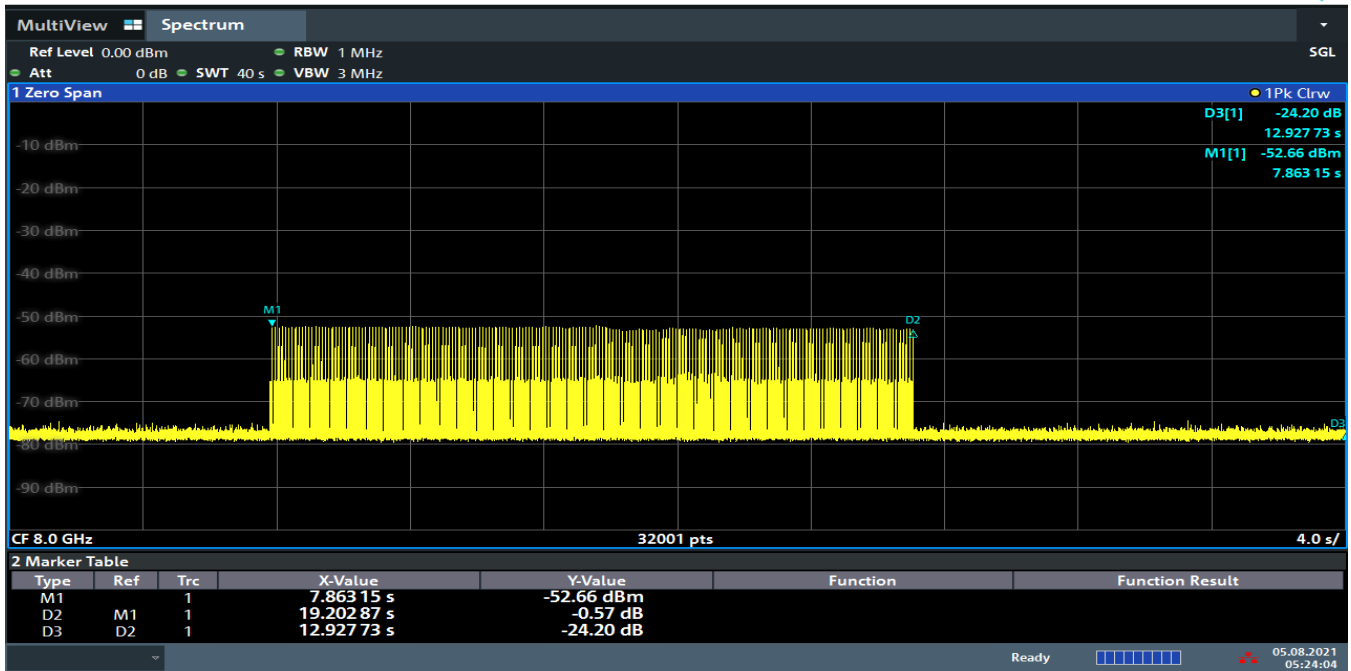

05:24:05 05.08.2021

Plot 7-14. Cessation Time – Mode2 (Ch. 9, 8 GHz)

FCC ID: BCG-A2473 IC: 579C-A2473	PCTEST Proud to be part of element	MEASUREMENT REPORT (CERTIFICATION)	Approved by: Quality Manager
Test Report S/N: 1C2106070041-08.BCG	Test Dates: 06/08/2021-08/06/2021	EUT Type: Watch	Page 30 of 63

7.6 Radiated Spurious Emissions – Above 960MHz

§15.519 (c) §15.519 (d); RSS-220 [5.3.1(d)] RSS-220 [5.3.1(e)]

Test Overview and Limit

All out of band radiated spurious emissions are measured with a spectrum analyzer connected to a receive antenna while the EUT is operating at maximum power and at the appropriate frequencies. Only the radiated emissions of the configuration that produced the worst case emissions are reported in this section.

All out of band emissions must not exceed the average limits shown in Table 7-12 and Table 7-13 per Section 15.519 (C) and RSS-220[5.3.1(d)] when measured using a resolution bandwidth of 1 MHz:

Frequency [MHz]	EIRP [dBm]
960-1610	-75.3
1610-1990	-63.3
1990-3100	-61.3
3100-10600	-41.3
Above 10600	-61.3

Table 7-12. FCC 15.519 Radiated Spurious Emissions Limits

Frequency [MHz]	EIRP [dBm]
960-1610	-75.3
1610-4750	-70.0
4750-10600	-41.3
Above 10600	-61.3

Table 7-13. RSS-220 Radiated Spurious Emissions Limits

All out of band emissions must not exceed the average limits shown in Table 7-14 per Section 15.519 (d) and RSS-220(5.3.1)(e) when measured using a resolution bandwidth greater than or equal to 1 kHz. The measurements shall demonstrate compliance with the stated limits at whatever resolution bandwidth is used.

Frequency [MHz]	EIRP [dBm]
1164-1240	-85.3
1559-1610	-85.3

Table 7-14. FCC 15.519/RSS-220 Radiated Spurious Emissions Limits for GPS frequency bands

Test Procedures Used

ANSI C63.10-2013 – Section 10.3
KDB 393764 D01 v02

FCC ID: BCG-A2473 IC: 579C-A2473	 PCTEST® Proud to be part of element	MEASUREMENT REPORT (CERTIFICATION)	Approved by: Quality Manager
Test Report S/N: 1C2106070041-08.BCG	Test Dates: 06/08/2021-08/06/2021	EUT Type: Watch	Page 31 of 63

Test Settings

Average RSE Measurements

1. RBW = 1MHz (30kHz for emissions in the GPS band)
2. VBW = 3MHz (100kHz for emissions in the GPS band)
3. Detector = Average (RMS)
4. Sweep time = No more than a 1 ms integration period over each measurement bin
5. Trace mode = Max hold
6. Trace was allowed to stabilize

Test Setup

The EUT and measurement equipment were set up as shown in the diagram below.

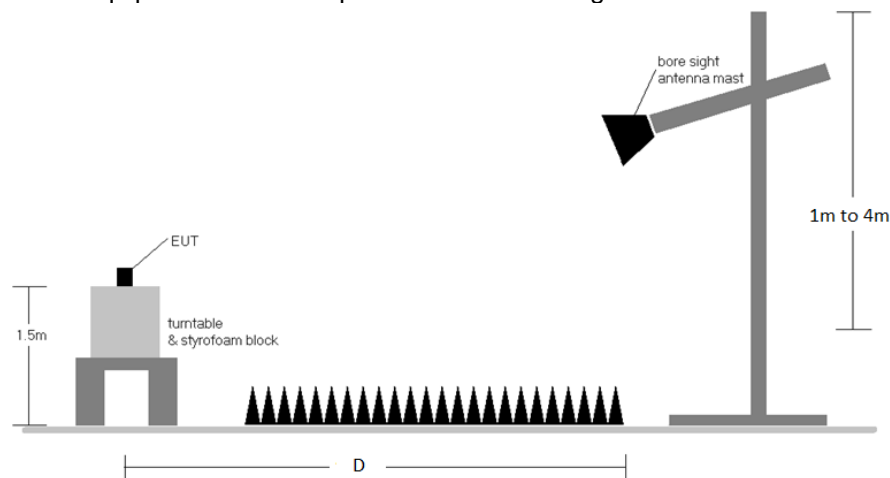

Figure 7-5. Radiated Test Setup - Above 960MHz

Test Notes

1. All modes of operation were investigated and the worst-case emissions are reported.
2. This unit was tested with its standard battery.
3. The RBW for measurements in the GPS Bands were reduced to 30kHz in order to show compliance.
4. D is the measurement test distance and emissions from 960MHz - 18GHz were measured at 0.6 meter test distance while emissions above 18GHz were measured at 0.5 meter test distance with the application of a distance correction factor.
5. The "-" shown in the following RSE tables are used to denote a noise floor measurement.
6. 6GHz - 9GHz RSE is covered in EIRP section (Section 7.4).

FCC ID: BCG-A2473 IC: 579C-A2473		MEASUREMENT REPORT (CERTIFICATION)	Approved by: Quality Manager
Test Report S/N: 1C2106070041-08.BCG	Test Dates: 06/08/2021-08/06/2021	EUT Type: Watch	Page 32 of 63

Sample Calculations

Determining Spurious Emissions Levels

- $E_{[dB\mu V/m]} = \text{Analyzer level}_{[dBm]} + 107 + \text{AFCL}_{[dB/m]}$
- $\text{Spurious Emission Level}_{[dBm]} = E_{[dB\mu V/m]} + 20 \log(D_{\text{Meas}}) - 104.8$
- $\text{Spurious Emission Level}_{[dBm]} = \text{Analyzer Level}_{[dBm]} + \text{AFCL}_{[dB/m]} + \text{Conversion Factor}_{[dB]}$
- $\text{AFCL}_{[dB/m]} = (\text{Antenna Factor}_{[dB/m]} + \text{Cable Loss}_{[dB]} + \text{Attenuator}_{[dB]}) - \text{Preamp Gain}_{[dB]}$
- $\text{Conversion Factor}_{[dB]} = 107 - 104.8 + 20 \log(D_{\text{Meas}})$
- $\text{Margin}_{[dB]} = \text{Spurious Emission Level}_{[dBm]} - \text{Limit}_{[dBm]}$

FCC ID: BCG-A2473 IC: 579C-A2473	 MEASUREMENT REPORT (CERTIFICATION)	Approved by: Quality Manager
Test Report S/N: 1C2106070041-08.BCG	Test Dates: 06/08/2021-08/06/2021	EUT Type: Watch Page 33 of 63

7.6.1 Radiated Spurious Emissions (960MHz – 18GHz)

\$15.519 (c); RSS-220 [5.3.1(d)]

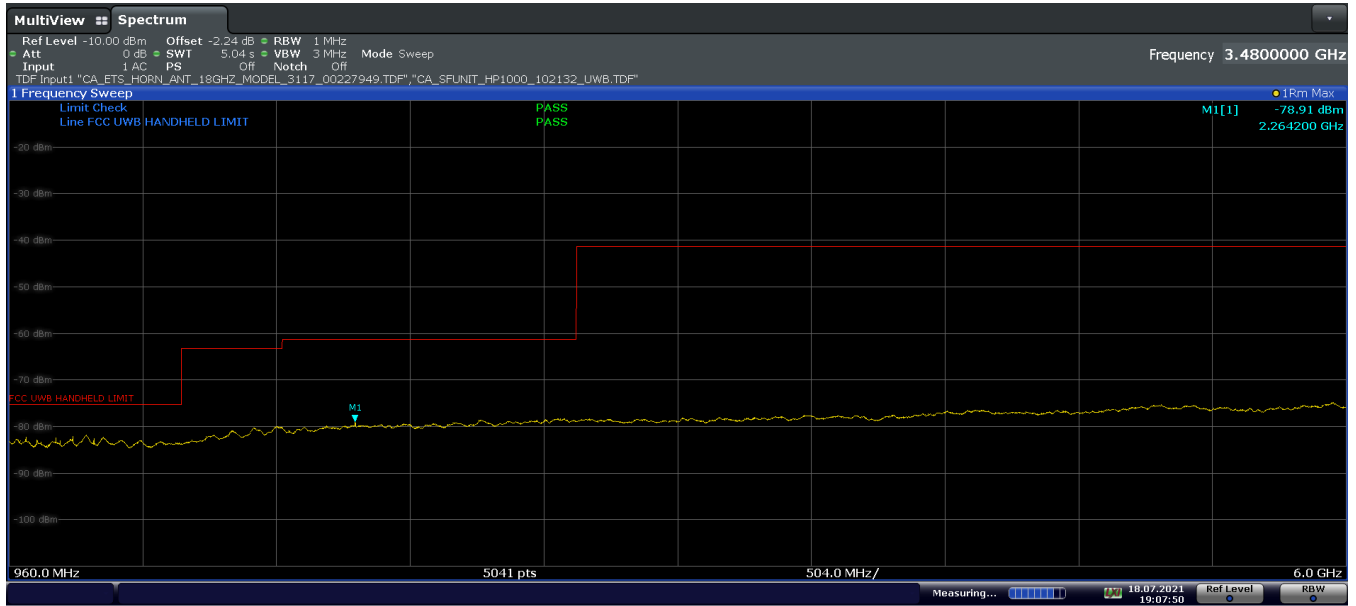

19:07:50 18.07.2021

Plot 7-15. FCC Radiated Spurious Emission 960-6000MHz (Ch. 5, Config 3, Payload 125 Ant. Pol. H)

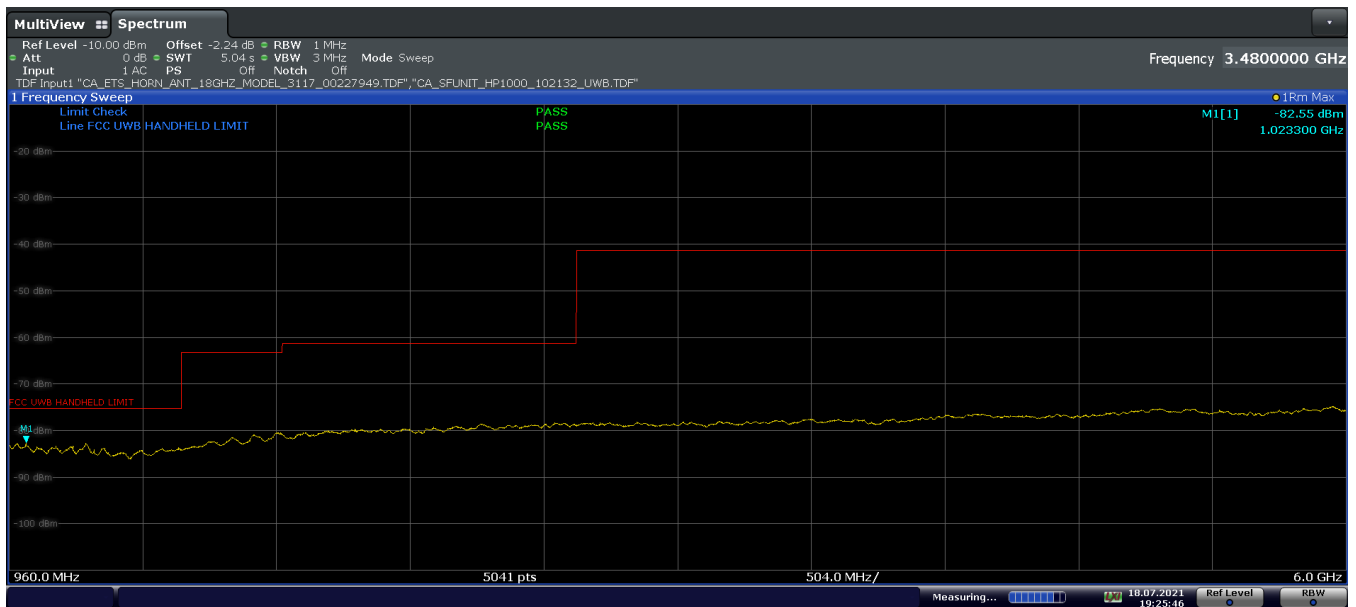

19:25:46 18.07.2021

Plot 7-16. FCC Radiated Spurious Emissions 960-6000MHz (Ch. 5, Config 3, Payload 125 Ant. Pol. V)

FCC ID: BCG-A2473 IC: 579C-A2473		MEASUREMENT REPORT (CERTIFICATION)	Approved by: Quality Manager
Test Report S/N: 1C2106070041-08.BCG	Test Dates: 06/08/2021-08/06/2021	EUT Type: Watch	Page 34 of 63

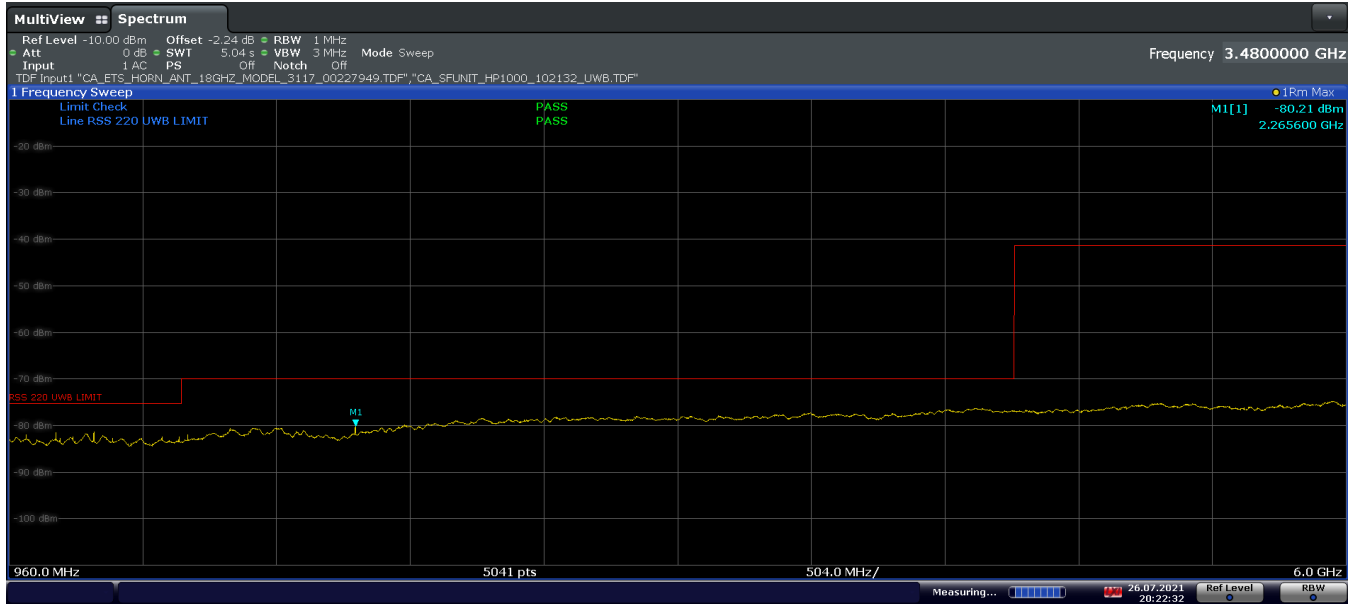

20:22:32 26.07.2021

Plot 7-17. ISED Radiated Spurious Emission 960-6000MHz (Ch. 5, Config 3, Payload 125 Ant. Pol. H)

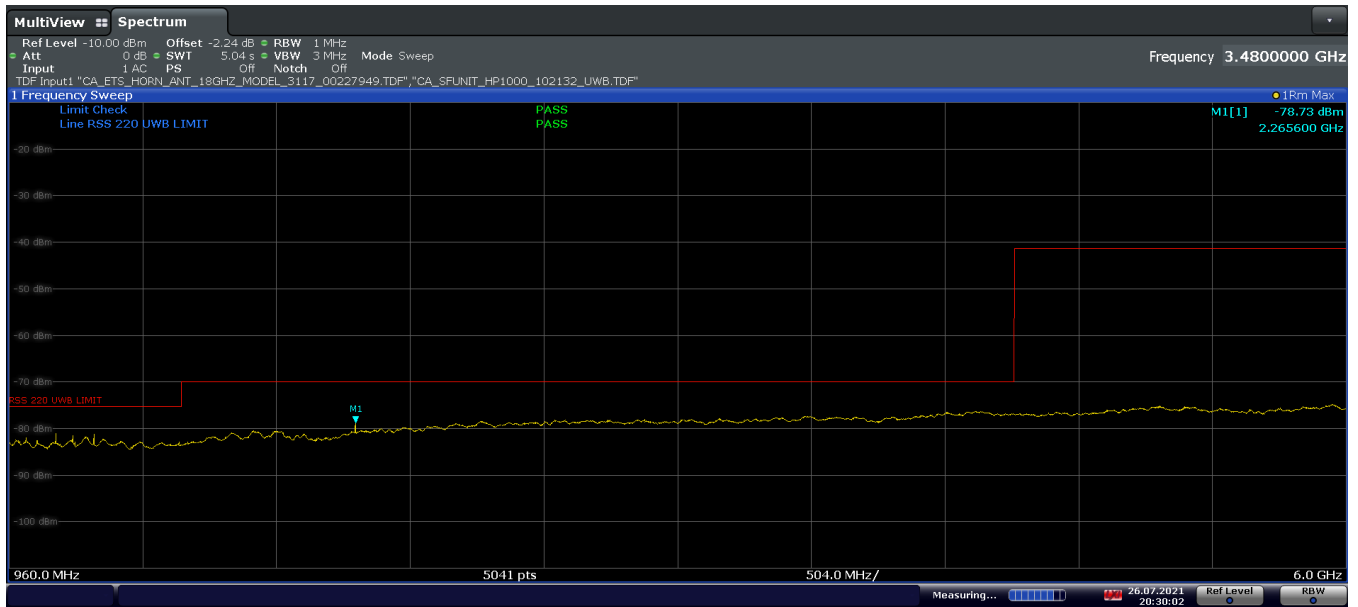

20:30:03 26.07.2021

Plot 7-18. ISED Radiated Spurious Emission 960-6000MHz (Ch. 5, Config 3, Payload 125 Ant. Pol. V)

FCC ID: BCG-A2473 IC: 579C-A2473		MEASUREMENT REPORT (CERTIFICATION)	Approved by: Quality Manager
Test Report S/N: 1C2106070041-08.BCG	Test Dates: 06/08/2021-08/06/2021	EUT Type: Watch	Page 35 of 63

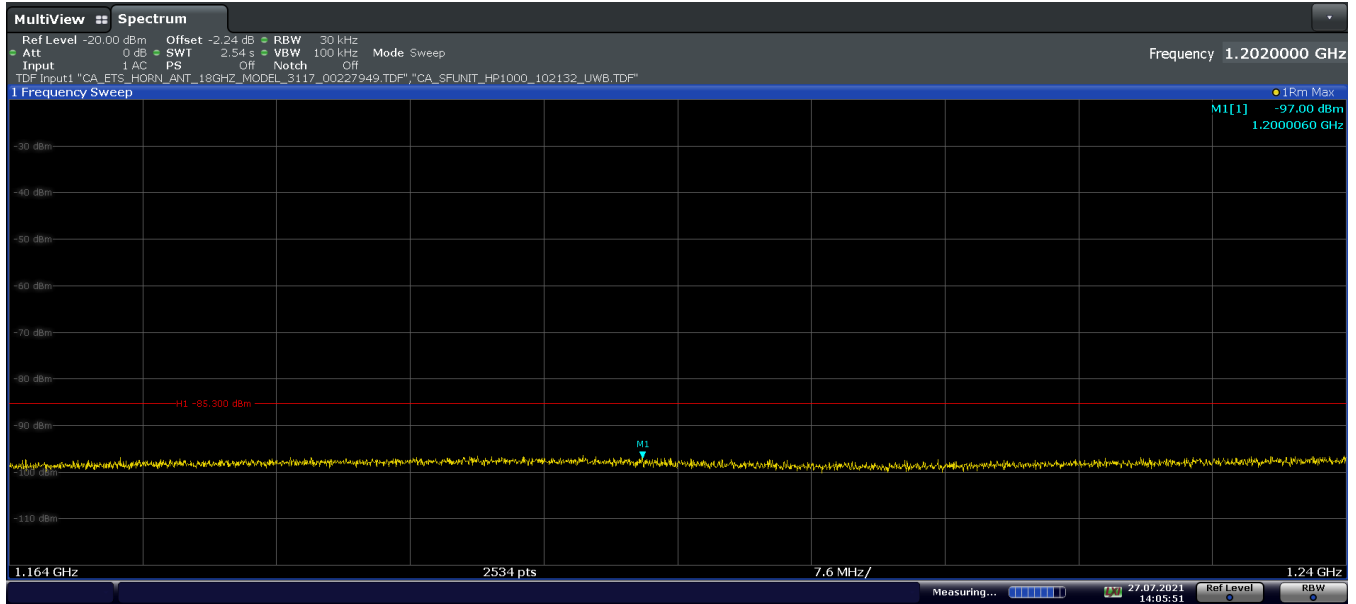

14:05:51 27.07.2021

Plot 7-19. Radiated Spurious Emission 1164-1240MHz (Ch. 5, Config 3, Payload 125 Ant. Pol. H)

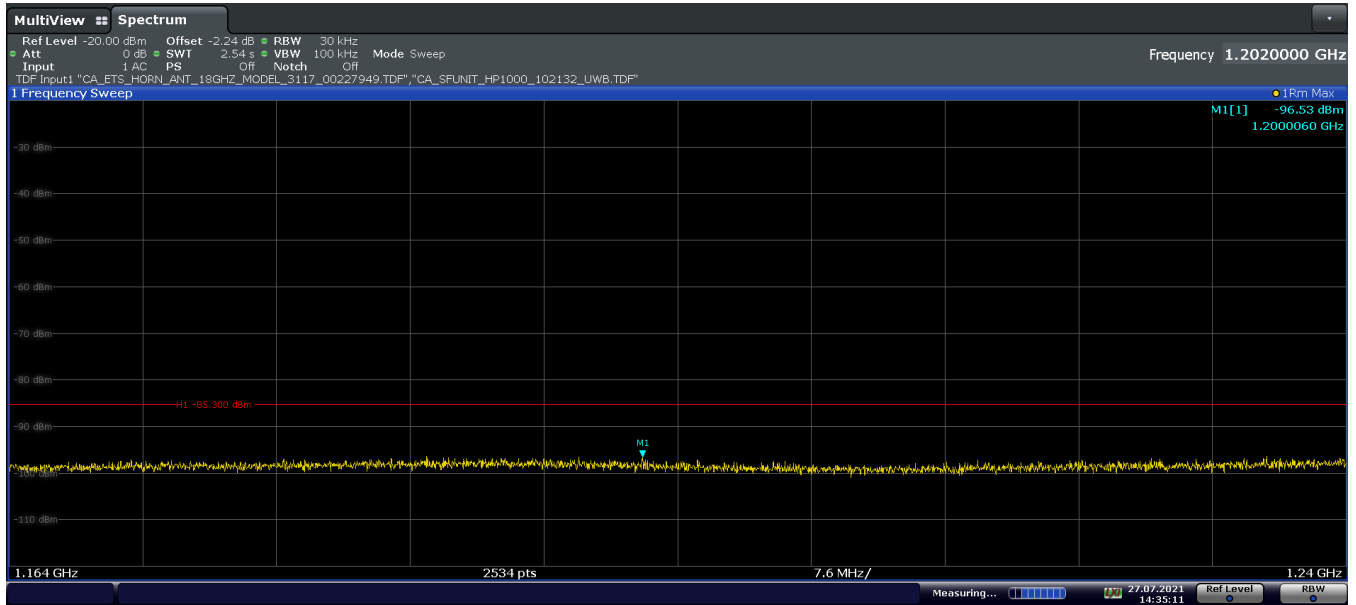

14:35:11 27.07.2021

Plot 7-20. Radiated Spurious Emission 1164-1240MHz (Ch. 5, Config 3, Payload 125 Ant. Pol. V)

FCC ID: BCG-A2473 IC: 579C-A2473		MEASUREMENT REPORT (CERTIFICATION)	Approved by: Quality Manager
Test Report S/N: 1C2106070041-08.BCG	Test Dates: 06/08/2021-08/06/2021	EUT Type: Watch	Page 36 of 63

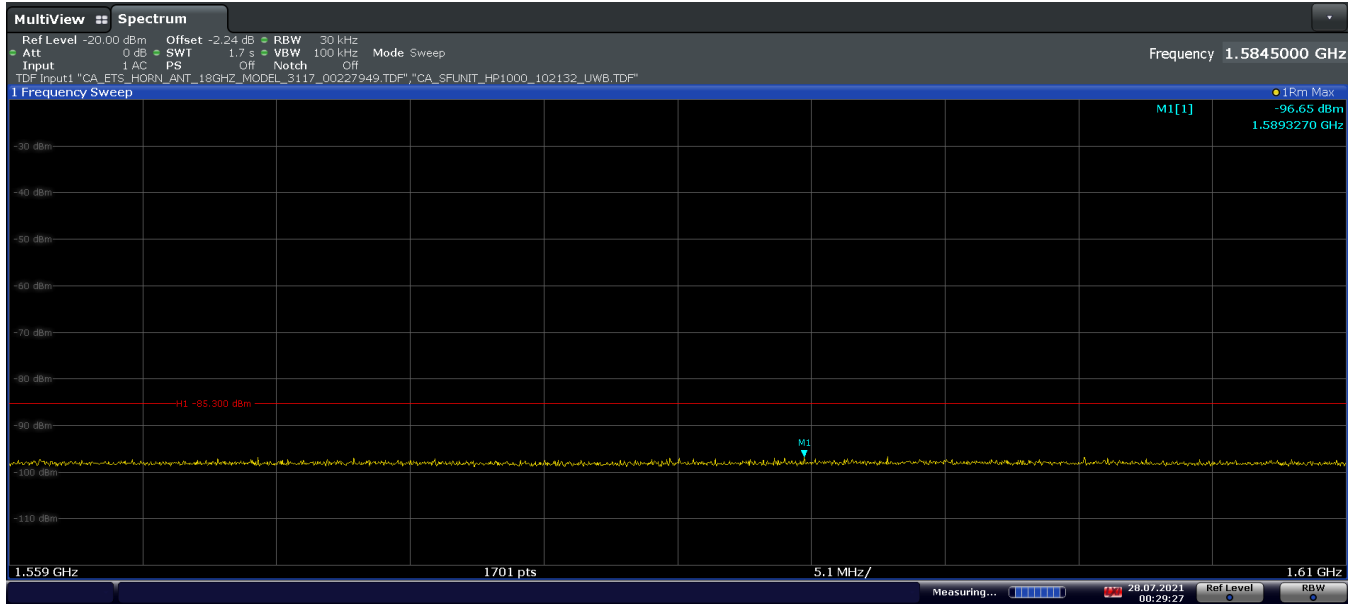

00:29:27 28.07.2021

Plot 7-21. Radiated Spurious Emission 1559-1610MHz (Ch. 5, Config 3, Payload 125 Ant. Pol. H)

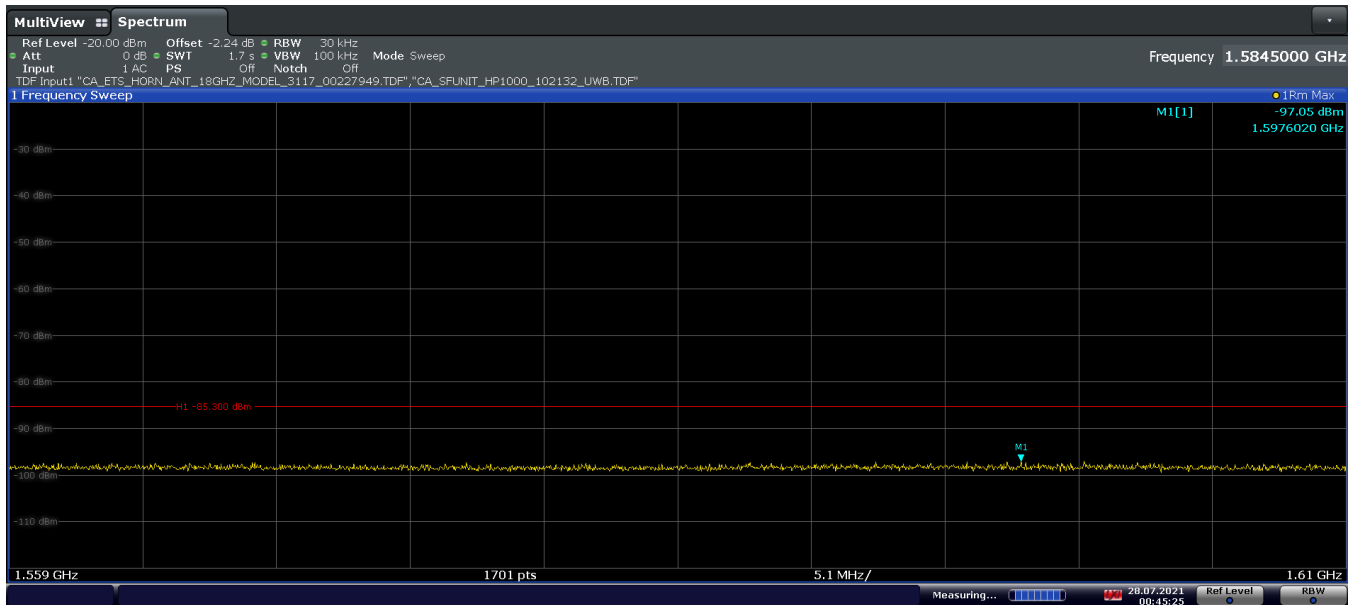

00:45:25 28.07.2021

Plot 7-22. Radiated Spurious Emission 1559-1610MHz (Ch. 5, Config 3, Payload 125 Ant. Pol. V)

FCC ID: BCG-A2473 IC: 579C-A2473		MEASUREMENT REPORT (CERTIFICATION)	Approved by: Quality Manager
Test Report S/N: 1C2106070041-08.BCG	Test Dates: 06/08/2021-08/06/2021	EUT Type: Watch	Page 37 of 63

© 2021 PCTEST

V 10.1 02/01/2020

All rights reserved. Unless otherwise specified, no part of this report may be reproduced or utilized in any part, form or by any means, electronic or mechanical, including photocopying and microfilm, without permission in writing from PCTEST. If you have any questions about this international copyright or have an enquiry about obtaining additional rights to this report or assembly of contents thereof, please contact INFO@PCTEST.COM.

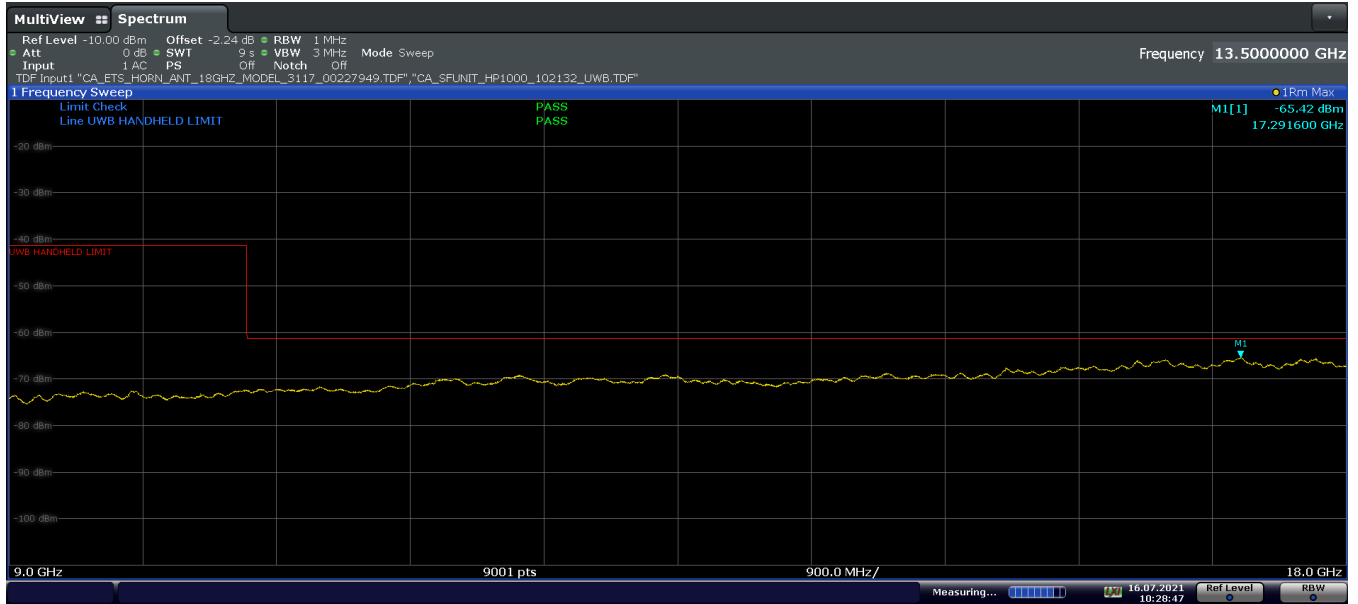

10:28:48 16.07.2021

Plot 7-23. Radiated Spurious Emission 9-18GHz (Ch. 5, Config 3, Payload 125 Ant. Pol. H)

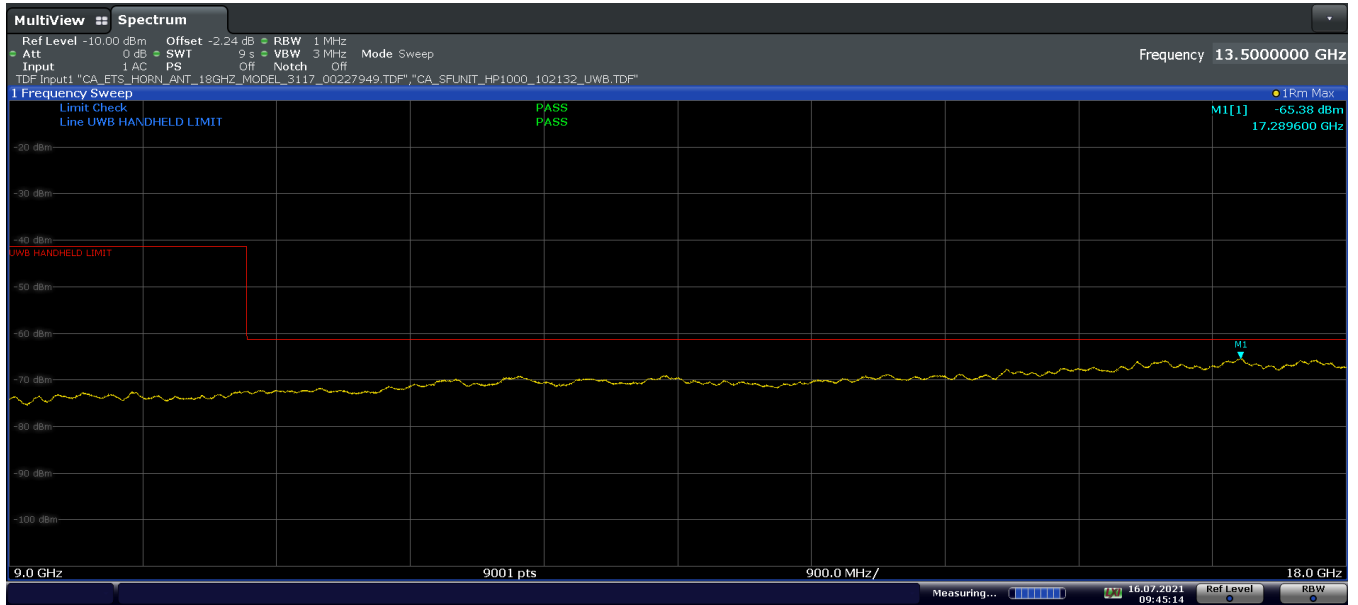

09:45:14 16.07.2021

Plot 7-24. Radiated Spurious Emission 9-18GHz (Ch. 5, Config 3, Payload 125 Ant. Pol. V)

FCC ID: BCG-A2473 IC: 579C-A2473		MEASUREMENT REPORT (CERTIFICATION)	Approved by: Quality Manager
Test Report S/N: 1C2106070041-08.BCG	Test Dates: 06/08/2021-08/06/2021	EUT Type: Watch	Page 38 of 63

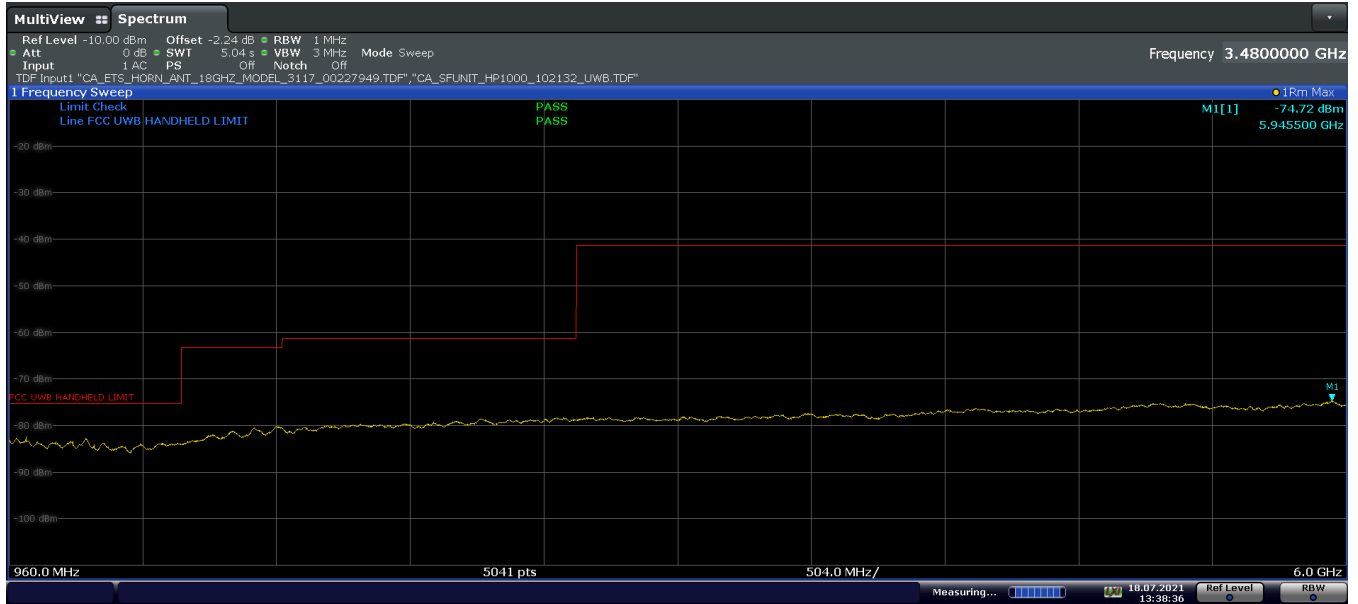

13:38:37 18.07.2021

Plot 7-25. FCC Radiated Spurious Emission 960-6000MHz (Ch. 9, Config 3, Payload 125 Ant. Pol. H)

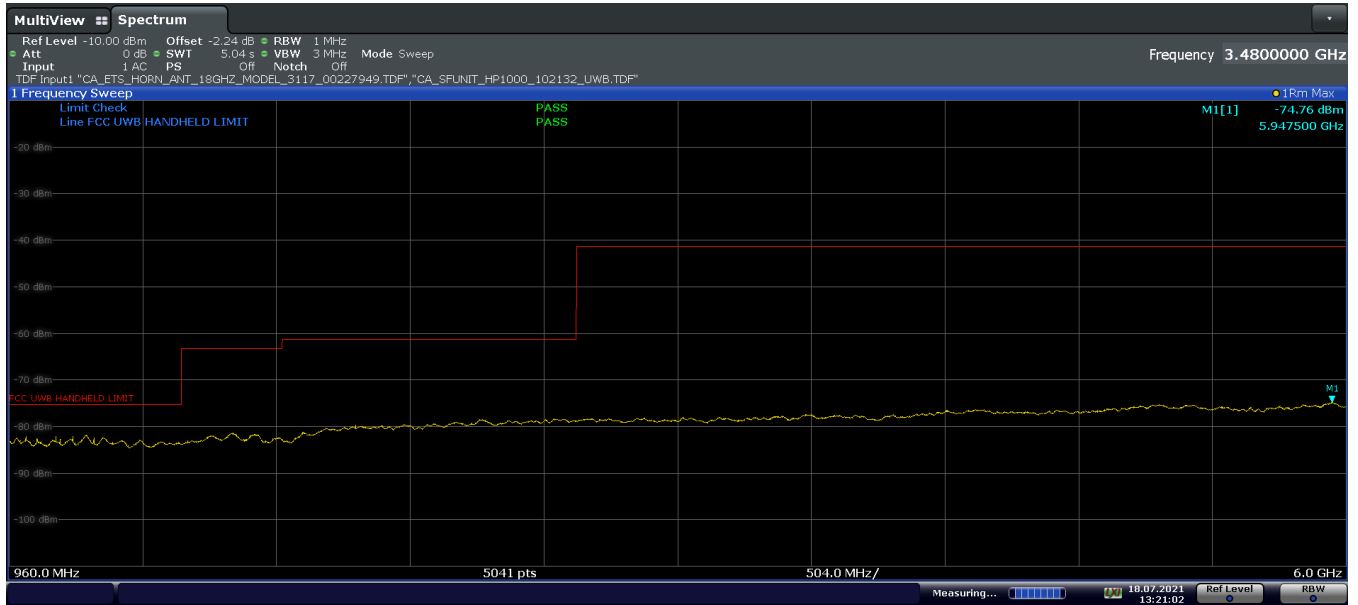

13:21:02 18.07.2021

Plot 7-26. FCC Radiated Spurious Emission 960-6000MHz (Ch.9, Config 3, Payload 125 Ant. Pol. V)

FCC ID: BCG-A2473 IC: 579C-A2473		MEASUREMENT REPORT (CERTIFICATION)	Approved by: Quality Manager
Test Report S/N: 1C2106070041-08.BCG	Test Dates: 06/08/2021-08/06/2021	EUT Type: Watch	Page 39 of 63

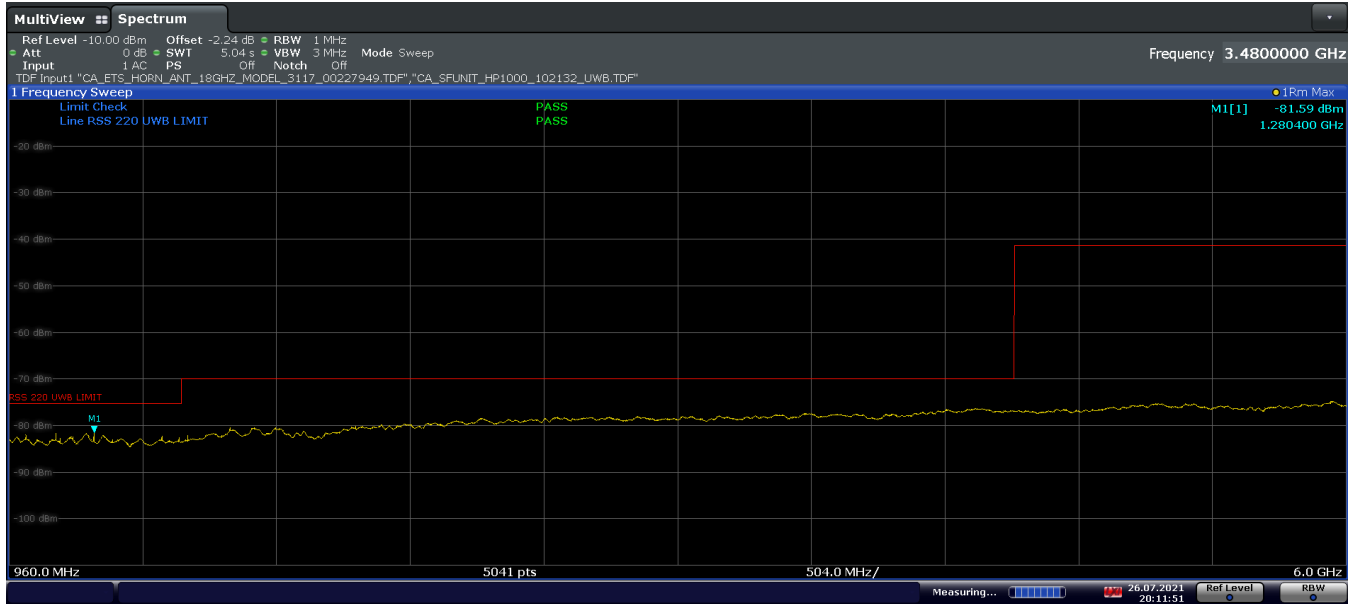

20:11:52 26.07.2021

Plot 7-27. ISED Radiated Spurious Emission 960-6000MHz (Ch. 9, Config 3, Payload 125 Ant. Pol. H)

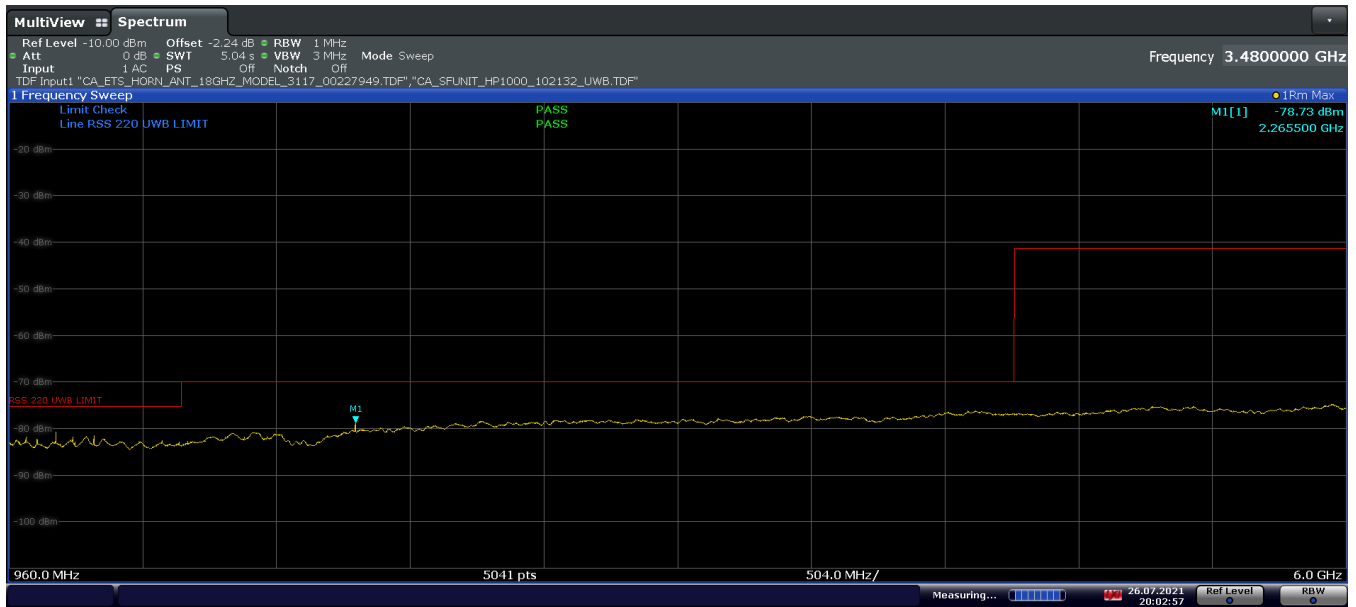

20:02:58 26.07.2021

Plot 7-28. ISED Radiated Spurious Emission 960-6000MHz (Ch.9, Config 3, Payload 125 Ant. Pol. V)

FCC ID: BCG-A2473 IC: 579C-A2473	 Proud to be part of element	MEASUREMENT REPORT (CERTIFICATION)	Approved by: Quality Manager
Test Report S/N: 1C2106070041-08.BCG	Test Dates: 06/08/2021-08/06/2021	EUT Type: Watch	Page 40 of 63

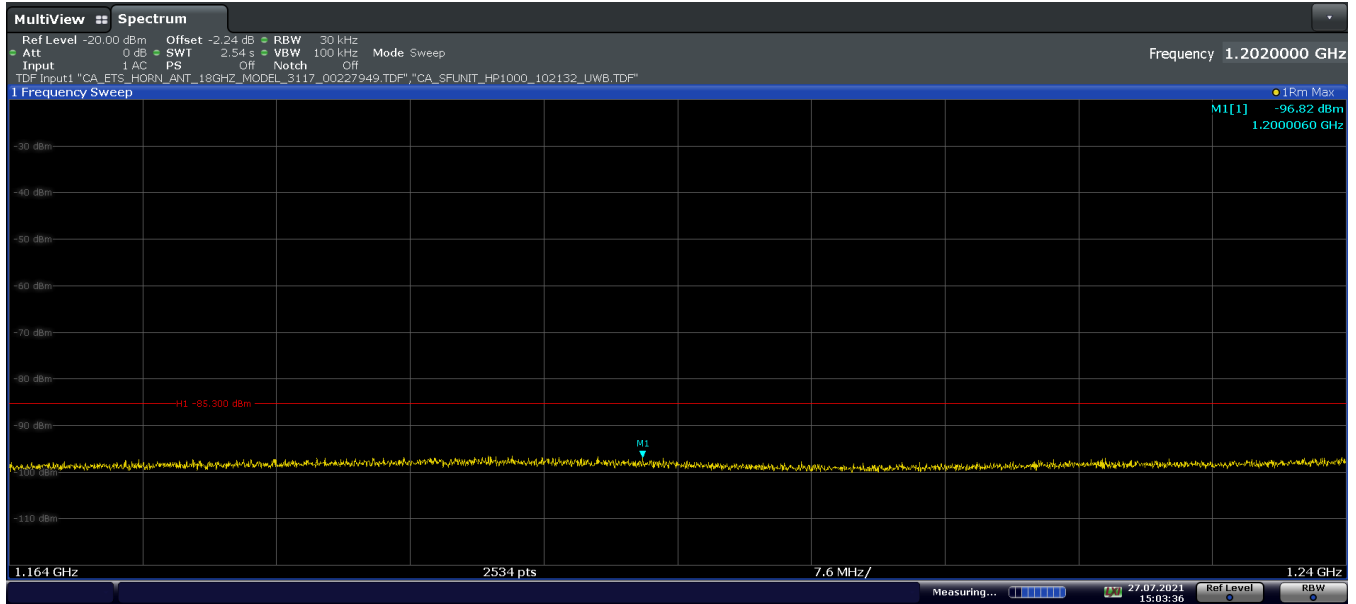

15:03:36 27.07.2021

Plot 7-29. Radiated Spurious Emission 1164-1240MHz (Ch. 9, Config 3, Payload 125 Ant. Pol. H)

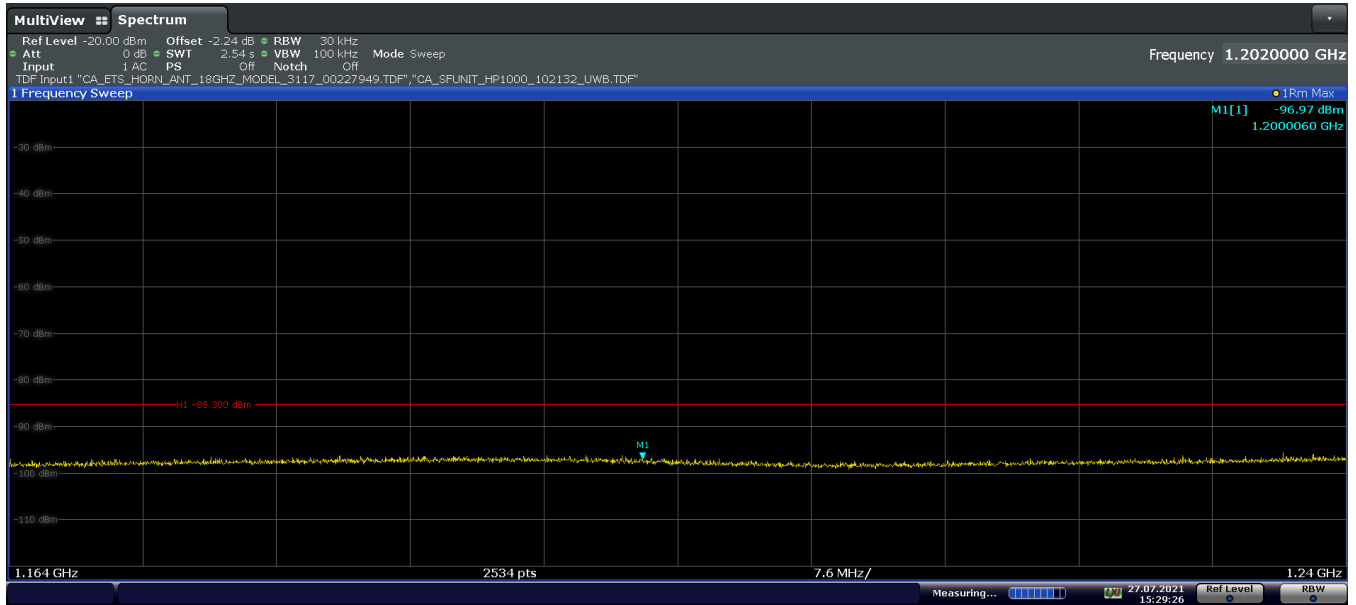

15:29:26 27.07.2021

Plot 7-30. Radiated Spurious Emission 1164-1240MHz (Ch. 9, Config 3, Payload 125 Ant. Pol. V)

FCC ID: BCG-A2473 IC: 579C-A2473		MEASUREMENT REPORT (CERTIFICATION)	Approved by: Quality Manager
Test Report S/N: 1C2106070041-08.BCG	Test Dates: 06/08/2021-08/06/2021	EUT Type: Watch	Page 41 of 63

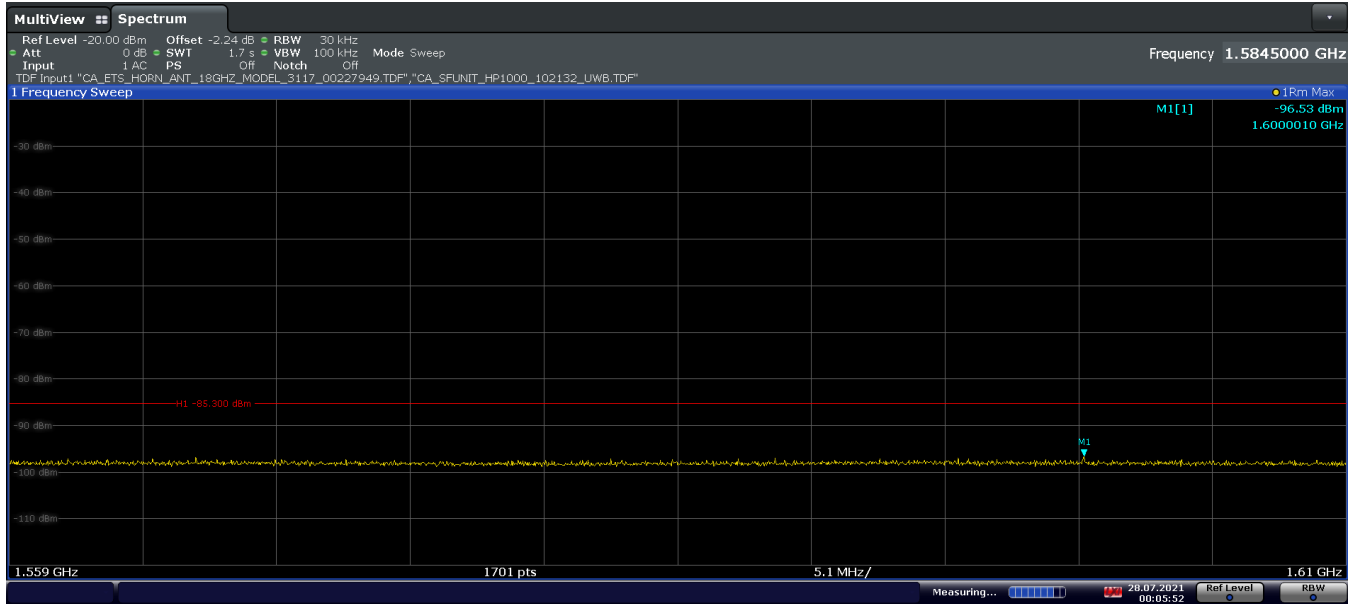

00:05:52 28.07.2021

Plot 7-31. Radiated Spurious Emission 1559-1610MHz (Ch. 9, Config 3, Payload 125 Ant. Pol. H)

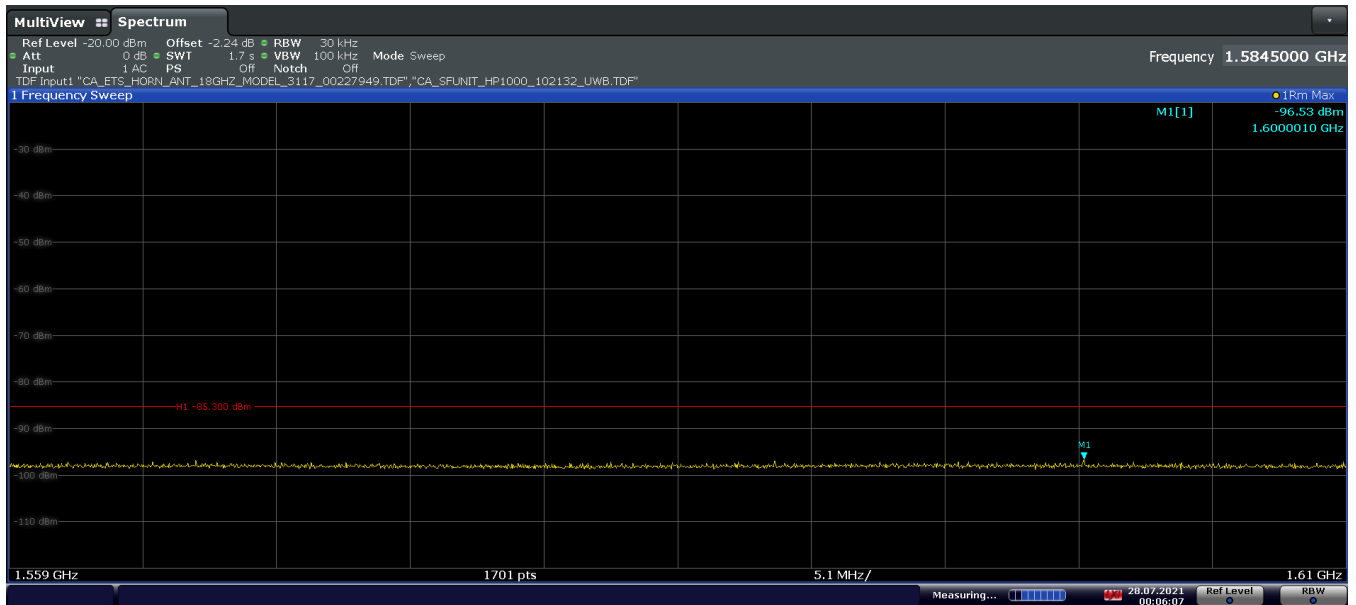

00:06:08 28.07.2021

Plot 7-32. Radiated Spurious Emission 1559-1610MHz (Ch. 9, Config 3, Payload 125 Ant. Pol. V)

FCC ID: BCG-A2473 IC: 579C-A2473		MEASUREMENT REPORT (CERTIFICATION)	Approved by: Quality Manager
Test Report S/N: 1C2106070041-08.BCG	Test Dates: 06/08/2021-08/06/2021	EUT Type: Watch	Page 42 of 63

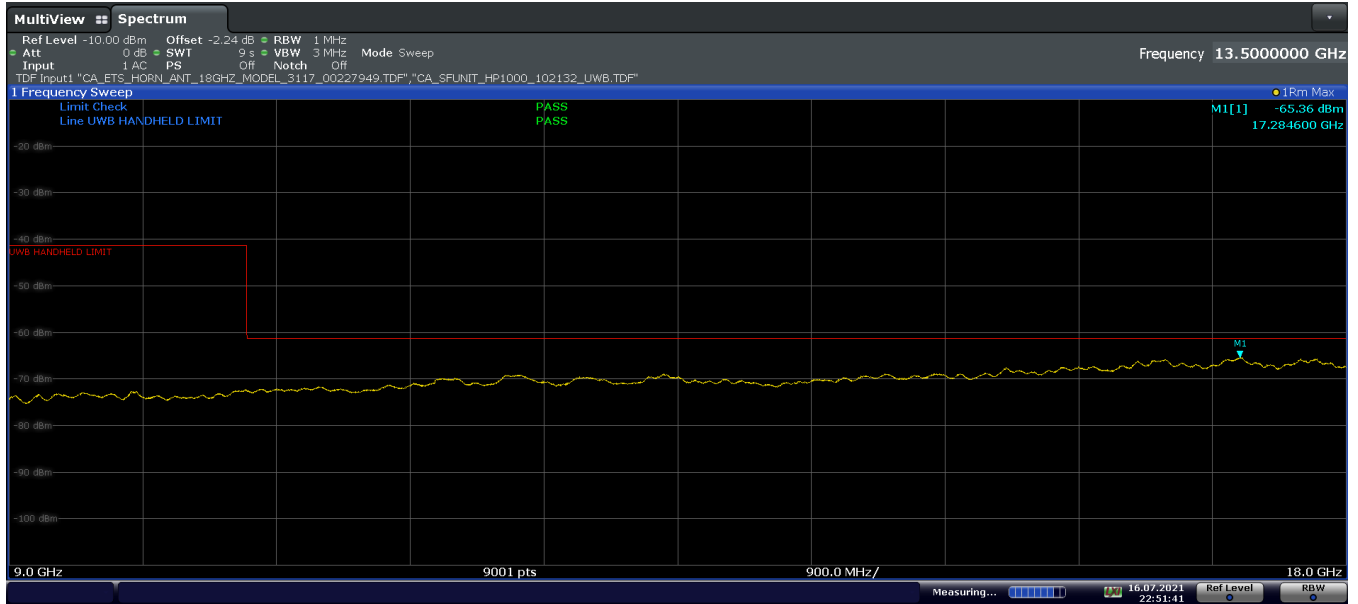

22:51:42 16.07.2021

Plot 7-33. Radiated Spurious Emission 9-18GHz (Ch. 9, Config 3, Payload 125 Ant. Pol. H)

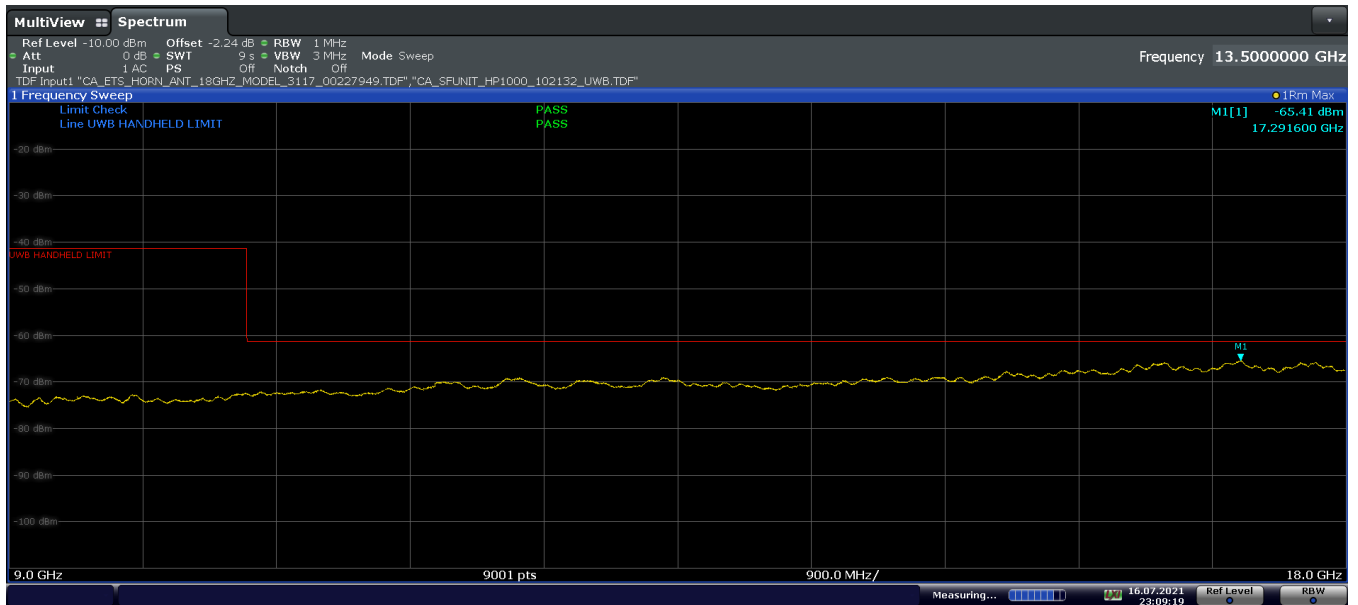

23:09:20 16.07.2021

Plot 7-34. Radiated Spurious Emission 9-18GHz (Ch. 9, Config 3, Payload 125 Ant. Pol. V)

FCC ID: BCG-A2473 IC: 579C-A2473	 Proud to be part of element	MEASUREMENT REPORT (CERTIFICATION)	Approved by: Quality Manager
Test Report S/N: 1C2106070041-08.BCG	Test Dates: 06/08/2021-08/06/2021	EUT Type: Watch	Page 43 of 63

Radiated Spurious Emissions (Above 18GHz) §15.519 (c); RSS-220 [5.3.1(d)]

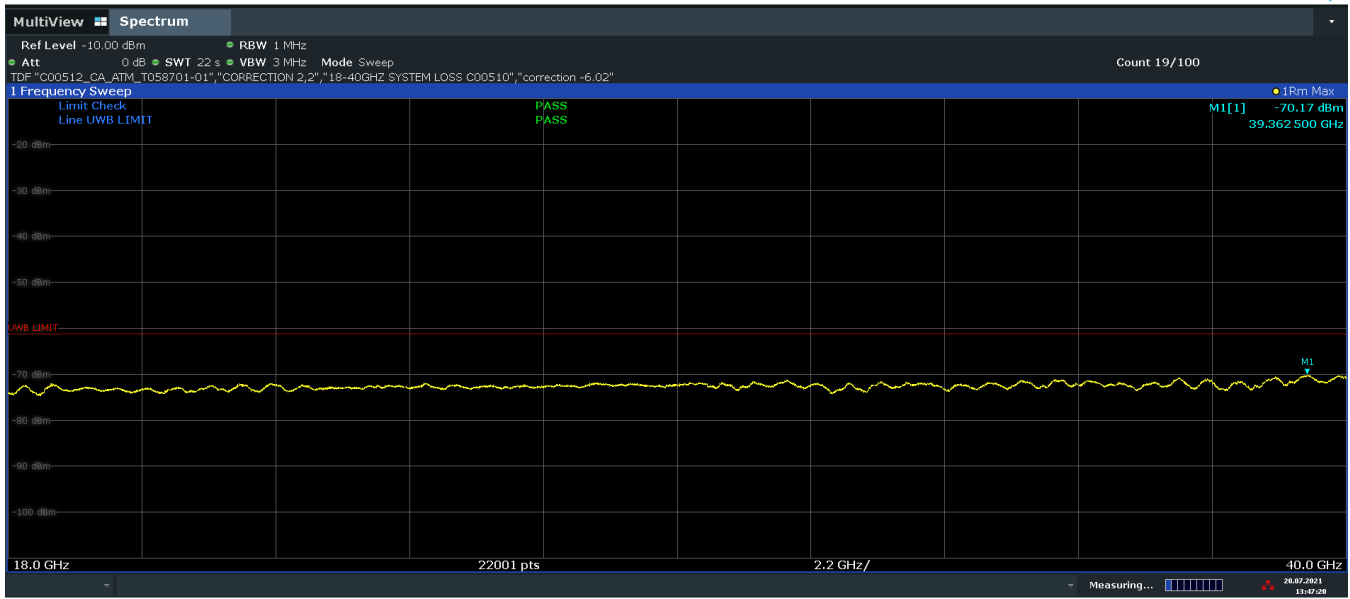

13:47:28 20.07.2021

Plot 7-35. Radiated Spurious Emission 18-40GHz (Ch. 5, Config 3, Payload 125 Ant. Pol. H)

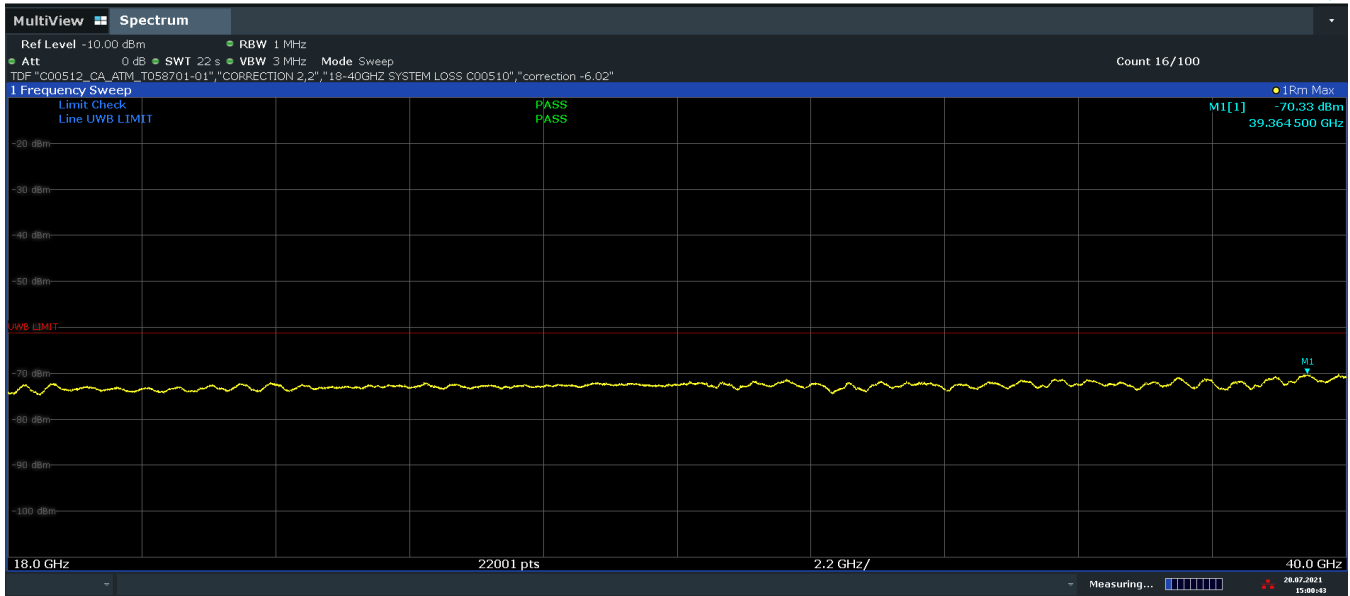

15:00:44 20.07.2021

Plot 7-36. Radiated Spurious Emission 18-40GHz (Ch. 5, Config 3, Payload 125 Ant. Pol. V)

FCC ID: BCG-A2473 IC: 579C-A2473		MEASUREMENT REPORT (CERTIFICATION)	Approved by: Quality Manager
Test Report S/N: 1C2106070041-08.BCG	Test Dates: 06/08/2021-08/06/2021	EUT Type: Watch	Page 44 of 63

© 2021 PCTEST

V 10.1 02/01/2020

All rights reserved. Unless otherwise specified, no part of this report may be reproduced or utilized in any part, form or by any means, electronic or mechanical, including photocopying and microfilm, without permission in writing from PCTEST. If you have any questions about this international copyright or have an enquiry about obtaining additional rights to this report or assembly of contents thereof, please contact INFO@PCTEST.COM.

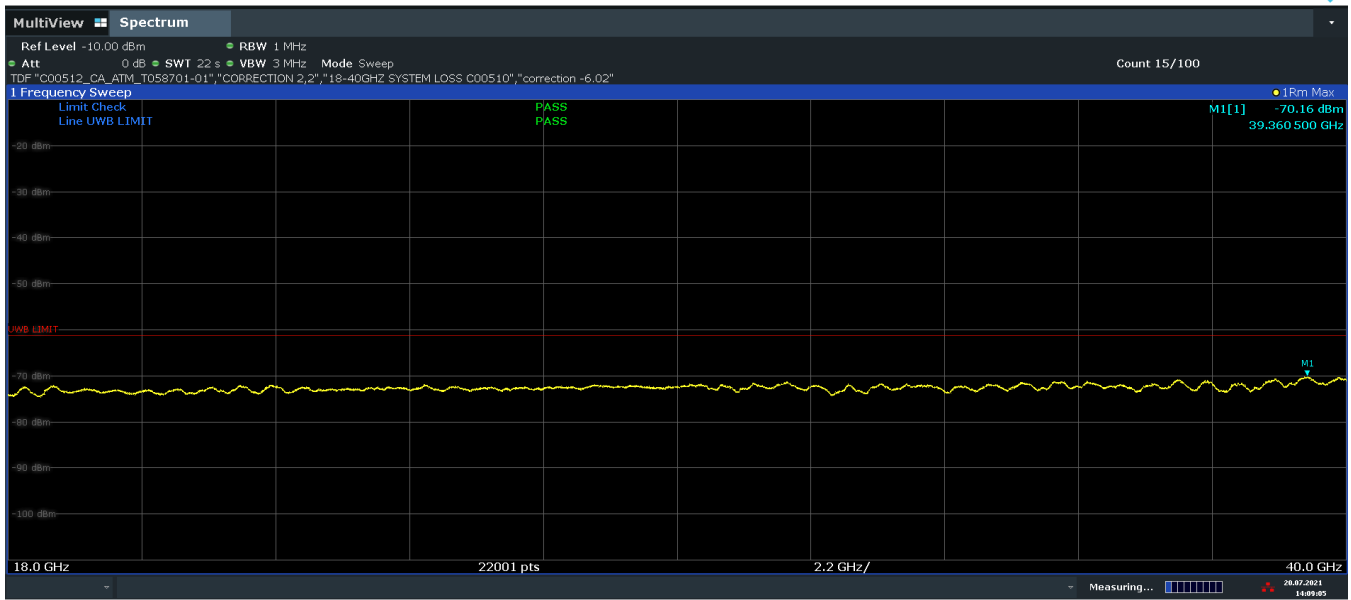

Plot 7-37. Radiated Spurious Emission 18-40GHz (Ch. 9, Config 3, Payload 125 Ant. Pol. H)

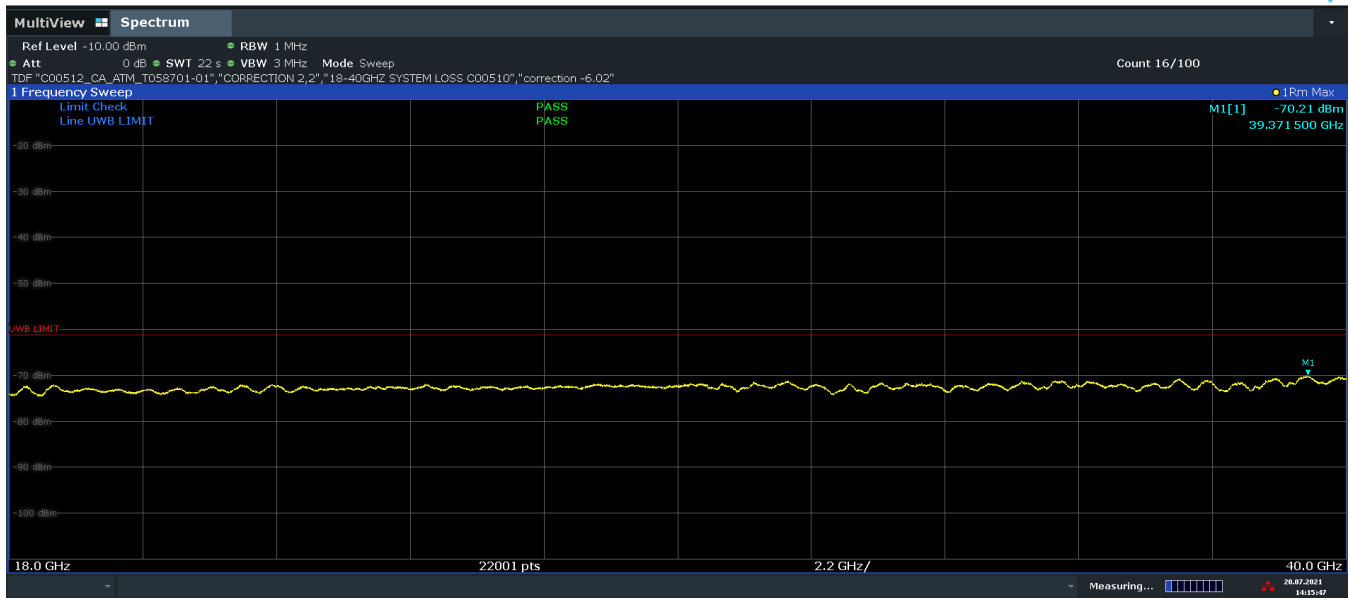

Plot 7-38. Radiated Spurious Emission 18-40GHz (Ch. 9, Config 3, Payload 125 Ant. Pol. V)

FCC ID: BCG-A2473 IC: 579C-A2473		MEASUREMENT REPORT (CERTIFICATION)	Approved by: Quality Manager
Test Report S/N: 1C2106070041-08.BCG	Test Dates: 06/08/2021-08/06/2021	EUT Type: Watch	Page 45 of 63

Radiated Spurious Emission Measurements (960MHz-18GHz) §15.519 (c); RSS-220 [5.3.1(d)]

Distance of Measurements: 0.6 Meter
 Operating Frequency: 6500 MHz
 Channel: 5
 Config: 3
 Payload: 125

Frequency [MHz]	Detector	Ant. Pol. [H/V]	Antenna Height [cm]	Turntable Azimuth [degree]	Analyzer Level [dBm]	AFCL [dB/m]	Conversion Factor [dB]	Spurious Emission Level [dBm]	Limit [dBm]	Margin [dB]
1023	Avg	H	-	-	-74.46	-5.66	-2.24	-82.36	-75.30	-7.06
1985	Avg	H	-	-	-76.11	-1.83	-2.24	-80.18	-63.30	-16.88
2264	Avg	H	135	252	-75.13	-1.29	-2.24	-78.66	-61.30	-17.36
13451	Avg	H	-	-	-75.94	9.06	-2.24	-69.12	-61.30	-7.82
15305	Avg	H	-	-	-75.18	9.27	-2.24	-68.15	-61.30	-6.85
17292	Avg	H	-	-	-75.37	11.97	-2.24	-65.64	-61.30	-4.34

Table 7-15. Radiated Spurious Emission Measurements 960MHz-18GHz (FCC)

Distance of Measurements: 0.6 Meter
 Operating Frequency: 6500 MHz
 Channel: 5
 Config: 3
 Payload: 125

Frequency [MHz]	Detector	Ant. Pol. [H/V]	Antenna Height [cm]	Turntable Azimuth [degree]	Analyzer Level [dBm]	AFCL [dB/m]	Conversion Factor [dB]	Spurious Emission Level [dBm]	Limit [dBm]	Margin [dB]
1248	Avg	V	-	-	-74.86	-4.69	-2.24	-81.79	-75.30	-6.49
2266	Avg	V	132	250	-75.25	-1.28	-2.24	-78.77	-70.00	-8.77
4611	Avg	V	-	-	-76.53	2.44	-2.24	-76.33	-70.00	-6.33
13403	Avg	H	-	-	-75.69	9.01	-2.24	-68.92	-61.30	-7.62
17287	Avg	H	-	-	-77.86	11.95	-2.24	-68.15	-61.30	-6.85
17291	Avg	H	-	-	-75.41	11.98	-2.24	-65.67	-61.30	-4.37

Table 7-16. Radiated Spurious Emission Measurements 960MHz-18GHz (ISED)

FCC ID: BCG-A2473 IC: 579C-A2473		MEASUREMENT REPORT (CERTIFICATION)	Approved by: Quality Manager
Test Report S/N: 1C2106070041-08.BCG	Test Dates: 06/08/2021-08/06/2021	EUT Type: Watch	Page 46 of 63

Radiated Spurious Emission Measurements (960MHz-18GHz) §15.519 (c); RSS-220 [5.3.1(d)]

Distance of Measurements: 0.6 Meter
 Operating Frequency: 8000 MHz
 Channel: 9
 Config: 3
 Payload: 125

Frequency [MHz]	Detector	Ant. Pol. [H/V]	Antenna Height [cm]	Turntable Azimuth [degree]	Analyzer Level [dBm]	AFCL [dB/m]	Conversion Factor [dB]	Spurious Emission Level [dBm]	Limit [dBm]	Margin [dB]
1249	Avg	H	-	-	-75.73	-4.69	-2.24	-82.66	-75.30	-7.36
1971	Avg	H	-	-	-76.89	-1.74	-2.24	-80.87	-63.30	-17.57
2266	Avg	H	-	-	-76.59	-1.28	-2.24	-80.11	-61.30	-18.81
13463	Avg	H	-	-	-76.07	9.11	-2.24	-69.20	-61.30	-7.90
15296	Avg	H	-	-	-75.48	9.28	-2.24	-68.44	-61.30	-7.14
17291	Avg	H	-	-	-75.33	11.98	-2.24	-65.59	-61.30	-4.29

Table 7-17. Radiated Spurious Emission Measurements 960MHz-18GHz (FCC)

Distance of Measurements: 0.6 Meter
 Operating Frequency: 8000 MHz
 Channel: 9
 Config: 3
 Payload: 125

Frequency [MHz]	Detector	Ant. Pol. [H/V]	Antenna Height [cm]	Turntable Azimuth [degree]	Analyzer Level [dBm]	AFCL [dB/m]	Conversion Factor [dB]	Spurious Emission Level [dBm]	Limit [dBm]	Margin [dB]
1252	Avg	H	-	-	-74.92	-4.69	-2.24	-81.85	-75.30	-6.55
2266	Avg	H	130	249	-75.28	-1.28	-2.24	-78.80	-70.00	-8.80
4605	Avg	H	-	-	-76.53	2.44	-2.24	-76.33	-70.00	-6.33
13427	Avg	H	-	-	-75.89	9.19	-2.24	-68.95	-61.30	-7.65
15289	Avg	H	-	-	-75.77	9.27	-2.24	-68.74	-61.30	-7.44
17285	Avg	H	-	-	-75.41	11.93	-2.24	-65.72	-61.30	-4.42

Table 7-18. Radiated Spurious Emission Measurements 960MHz-18GHz (ISED)

FCC ID: BCG-A2473 IC: 579C-A2473		MEASUREMENT REPORT (CERTIFICATION)	Approved by: Quality Manager
Test Report S/N: 1C2106070041-08.BCG	Test Dates: 06/08/2021-08/06/2021	EUT Type: Watch	Page 47 of 63

Radiated Spurious Emission Measurements (Above 18GHz) §15.519 (c); RSS-220 [5.3.1(d)]

Distance of Measurements: 0.5 Meter
 Operating Frequency: 6500 MHz
 Channel: 5
 Config: 3
 Payload: 125

Frequency [MHz]	Detector	Ant. Pol. [H/V]	Antenna Height [cm]	Turntable Azimuth [degree]	Analyzer Level [dBm]	AFCL [dB/m]	Conversion Factor [dB]	Spurious Emission Level [dBm]	Limit [dBm]	Margin [dB]
19263	Avg	H	-	-	-61.39	-7.47	-3.82	-72.68	-61.30	-11.38
22307	Avg	H	-	-	-61.00	-7.11	-3.82	-71.93	-61.30	-10.63
25927	Avg	H	-	-	-61.94	-6.54	-3.82	-72.30	-61.30	-11.00
32359	Avg	H	-	-	-63.82	-3.92	-3.82	-71.56	-61.30	-10.26
39253	Avg	H	-	-	-62.95	-3.59	-3.82	-70.36	-61.30	-9.06

Table 7-19. Radiated Spurious Emission Measurements 18-40GHz

Distance of Measurements: 0.5 Meter
 Operating Frequency: 8000 MHz
 Channel: 9
 Config: 3
 Payload: 125

Frequency [MHz]	Detector	Ant. Pol. [H/V]	Antenna Height [cm]	Turntable Azimuth [degree]	Analyzer Level [dBm]	AFCL [dB/m]	Conversion Factor [dB]	Spurious Emission Level [dBm]	Limit [dBm]	Margin [dB]
19259	Avg	H	-	-	-61.55	-7.45	-3.82	-72.82	-61.30	-11.52
22304	Avg	H	-	-	-60.86	-7.13	-3.82	-71.81	-61.30	-10.51
25928	Avg	H	-	-	-62.05	-6.55	-3.82	-72.42	-61.30	-11.12
32361	Avg	H	-	-	-63.93	-3.93	-3.82	-71.68	-61.30	-10.38
39241	Avg	H	-	-	-63.06	-3.59	-3.82	-70.47	-61.30	-9.17

Table 7-20. Radiated Spurious Emission Measurements 18-40GHz

FCC ID: BCG-A2473 IC: 579C-A2473	 PCTEST® Proud to be part of element	MEASUREMENT REPORT (CERTIFICATION)	Approved by: Quality Manager
Test Report S/N: 1C2106070041-08.BCG	Test Dates: 06/08/2021-08/06/2021	EUT Type: Watch	Page 48 of 63

7.6.2 Simultaneous Tx Radiated Spurious Emission Measurements

§15.519(c) §15.247 §15.205 §15.209 & §27.53(m); RSS-220 [5.3.1(d)] RSS-Gen [8.9] & RSS-199[4.5]

Description	WLAN	UWB
Antenna	FCM	FCM
Channel	6	5
Operating Frequency (MHz)	2437	6500
Mode/Modulation	802.11b	Config 3/Payload125

Table 7-21. Worst Case Simultaneous Transmission Configuration

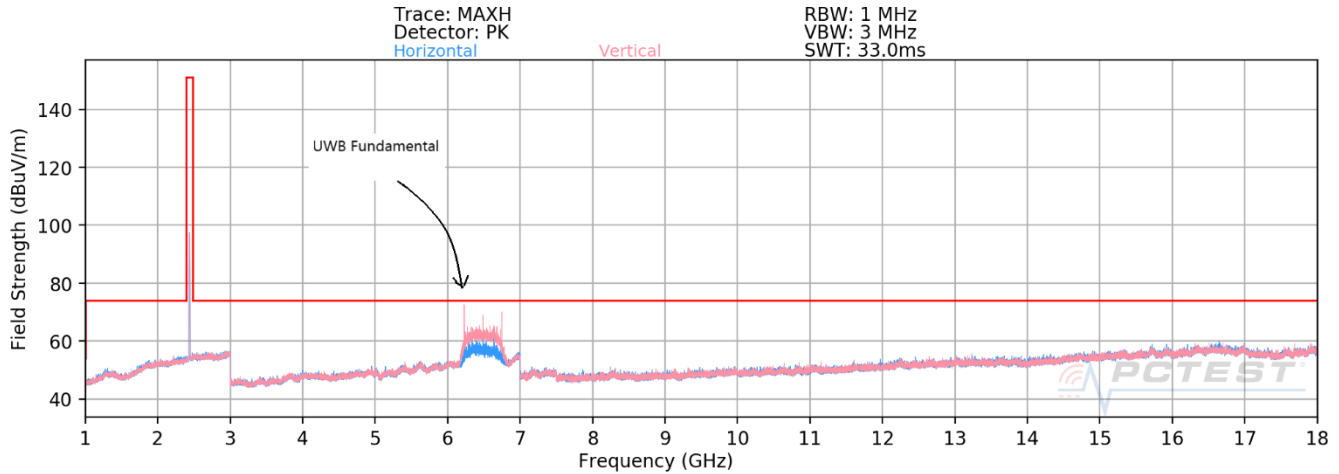

Plot 7-39. Radiated Spurious Simultaneous Transmission 1-18GHz (Ch. 5, Config 3, Payload 125)

Frequency [MHz]	Detector	Ant. Pol. [H/V]	Antenna Height [cm]	Turntable Azimuth [degree]	Analyzer Level [dBm]	AFCL [dB/m]	Field Strength [dBμV/m]	Limit [dBμV/m]	Margin [dB]
4874.00	Avg	V	101	281	-78.58	8.23	36.65	53.98	-17.33
4874.00	Peak	V	101	281	-69.26	8.23	45.97	73.98	-28.01
7311.00	Avg	V	302	222	-78.50	12.03	40.53	53.98	-13.45
7311.00	Peak	V	302	222	-68.89	12.03	50.14	73.98	-23.84
12185.00	Avg	V	-	-	-84.54	17.40	39.86	53.98	-14.12
12185.00	Peak	V	-	-	-73.20	17.40	51.20	73.98	-22.78

Table 7-22. WLAN Harmonics Emissions Measurement in Simultaneous Transmission

FCC ID: BCG-A2473 IC: 579C-A2473		MEASUREMENT REPORT (CERTIFICATION)	Approved by: Quality Manager
Test Report S/N: 1C2106070041-08.BCG	Test Dates: 06/08/2021-08/06/2021	EUT Type: Watch	Page 49 of 63

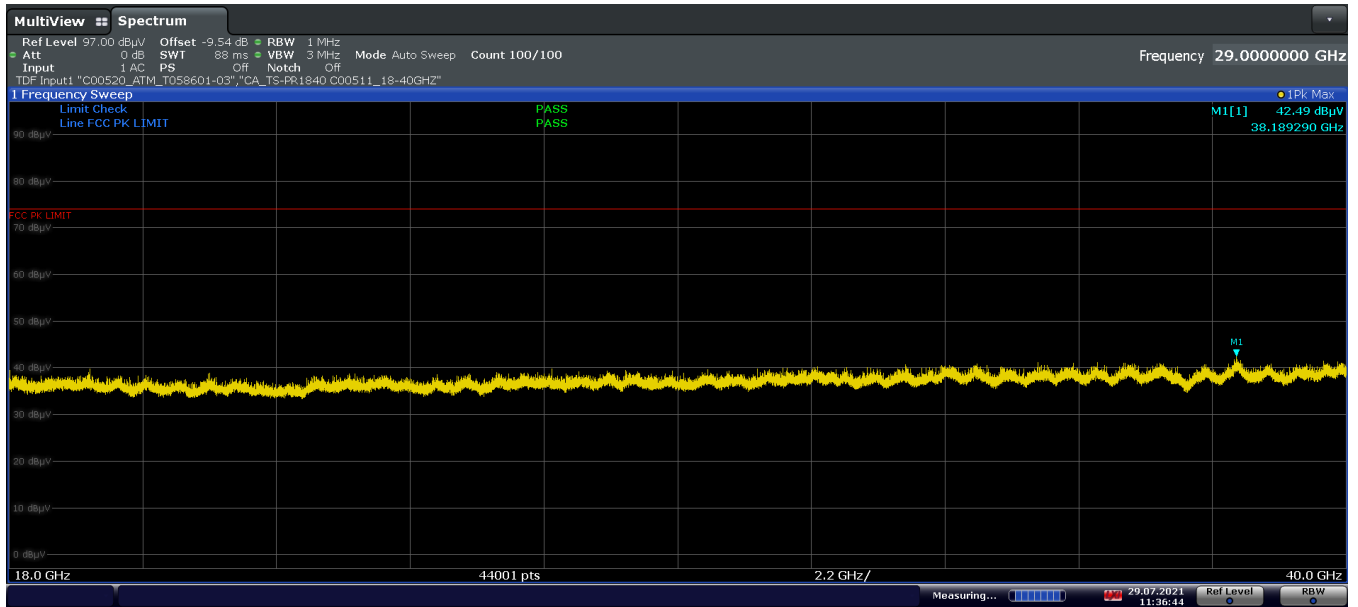

Plot 7-40. Radiated Spurious Emission- Simultaneous Transmission 18GHz-40GHz Pol. H

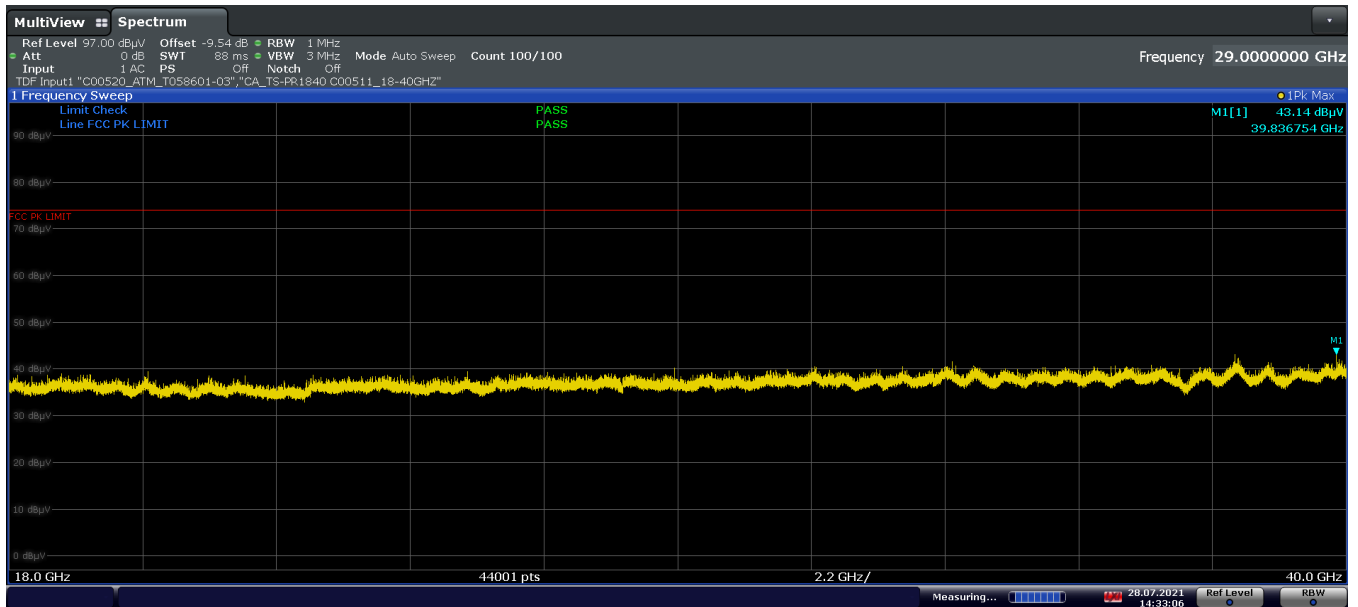

14:33:07 28.07.2021

Plot 7-41. Radiated Spurious Emission- Simultaneous Transmission 18GHz-40GHz Pol. V

FCC ID: BCG-A2473 IC: 579C-A2473		MEASUREMENT REPORT (CERTIFICATION)	Approved by: Quality Manager
Test Report S/N: 1C2106070041-08.BCG	Test Dates: 06/08/2021-08/06/2021	EUT Type: Watch	Page 50 of 63

7.7 Radiated Spurious Emissions – Below 960MHz §15.209; RSS-Gen [8.9]

Test Overview and Limit

All out of band radiated spurious emissions are measured with a spectrum analyzer connected to a receive antenna while the EUT is operating at its maximum duty cycle, at maximum power, and at the appropriate frequencies. All data rates and modes were investigated for radiated spurious emissions. Only the radiated emissions of the configuration that produced the worst case emissions are reported in this section.

All out of band emissions appearing in a restricted band as specified in Section 15.205 of the Title 47 CFR and Table 7 of RSS-Gen (8.10) must not exceed the limits shown in Table 7-23 per Section 15.209 and RSS-Gen (8.9).

Frequency	Field Strength [$\mu\text{V/m}$]	Measured Distance [Meters]
0.009 – 0.490 MHz	2400/F (kHz)	300
0.490 – 1.705 MHz	24000/F (kHz)	30
1.705 – 30.00 MHz	30	30
30.00 – 88.00 MHz	100	3
88.00 – 216.0 MHz	150	3
216.0 – 960.0 MHz	200	3
Above 960.0 MHz	500	3

Table 7-23. Radiated Limits

Test Procedures Used

ANSI C63.10-2013

Test Settings

Quasi-Peak Field Strength Measurements

7. Analyzer center frequency was set to the frequency of the radiated spurious emission of interest
8. RBW = 120kHz (for emissions from 30MHz – 1GHz)
9. Detector = quasi-peak
10. Sweep time = auto couple
11. Trace mode = max hold
12. Trace was allowed to stabilize

Peak Field Strength Measurements

1. Analyzer center frequency was set to the frequency of the radiated spurious emission of interest
2. RBW = 120kHz (for emissions from 30MHz – 1GHz)
3. VBW = 300kHz
4. Detector = peak
5. Sweep time = auto couple
6. Trace mode = max hold
7. Trace was allowed to stabilize

FCC ID: BCG-A2473 IC: 579C-A2473		MEASUREMENT REPORT (CERTIFICATION)	Approved by: Quality Manager
Test Report S/N: 1C2106070041-08.BCG	Test Dates: 06/08/2021-08/06/2021	EUT Type: Watch	Page 51 of 63

Test Setup

The EUT and measurement equipment were set up as shown in the diagrams below.

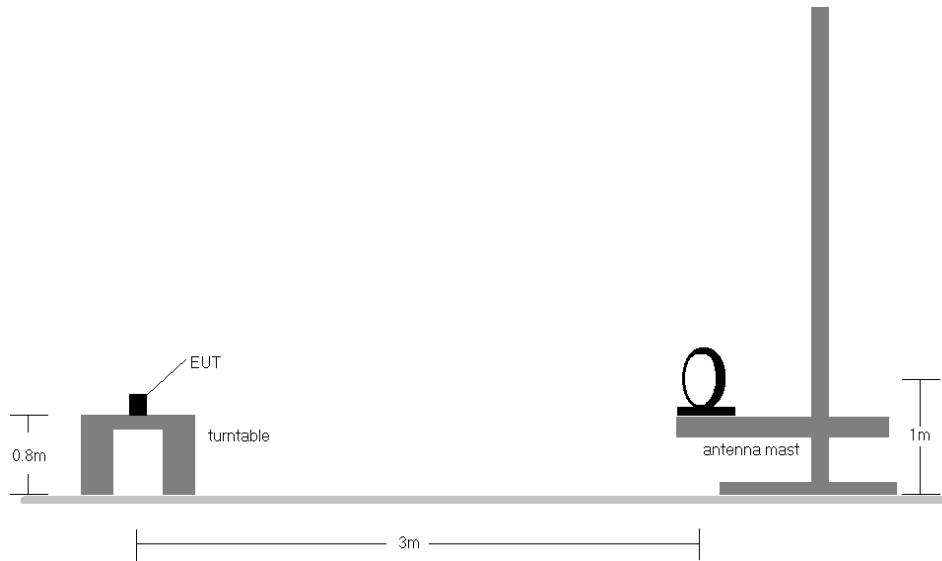

Figure 7-6. Radiated Test Setup < 30Mhz

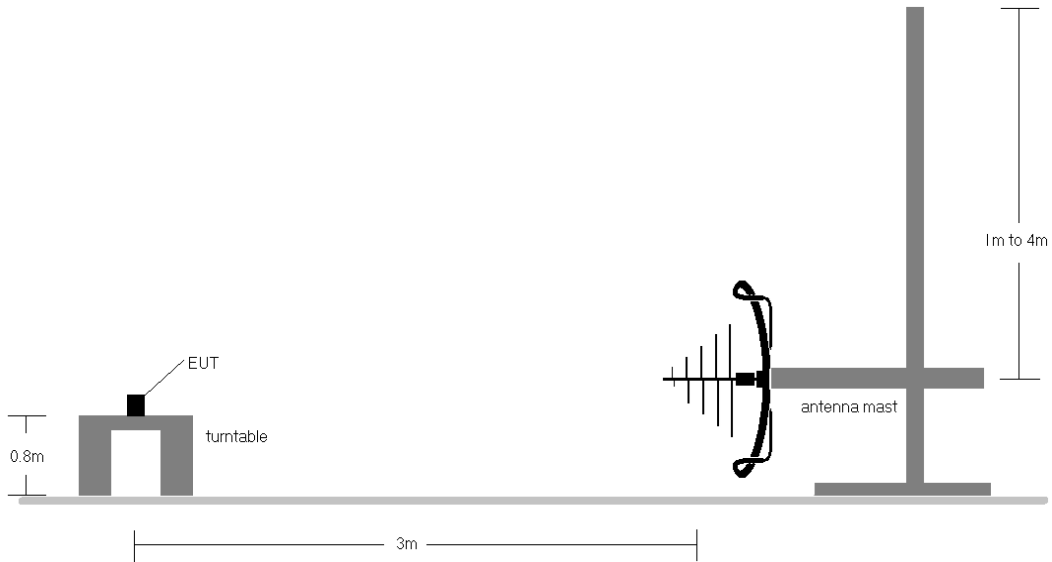

Figure 7-7. Radiated Test Setup < 1GHz

FCC ID: BCG-A2473 IC: 579C-A2473	PCTEST Proud to be part of element	MEASUREMENT REPORT (CERTIFICATION)	Approved by: Quality Manager
Test Report S/N: 1C2106070041-08.BCG	Test Dates: 06/08/2021-08/06/2021	EUT Type: Watch	Page 52 of 63

Test Notes

1. All emissions lying in restricted bands specified in §15.205 and RSS-Gen(8.10) are below the limit shown in Table 7-23.
2. The broadband receive antenna is manipulated through vertical and horizontal polarizations during the tests. The EUT is manipulated through three orthogonal planes. For below 30MHz the loop antenna was positioned in 3 orthogonal planes (X front, Y side, Z top) to determine the orientation resulting in the worst case emissions.
3. This unit was tested with its standard battery.
4. The spectrum is investigated using a peak detector and final measurements are recorded using CISPR quasi peak detector for emissions within 6dB of the limit.
5. Emissions were measured at a 3 meter test distance.
6. Emissions are investigated while operating on the center channel of the mode, band, and modulation that produced the worst case results during the transmitter spurious emissions testing.
7. Both configurations below were investigated, and the worst case has been reported.
 - a. EUT powered by AC/DC adapter via USB-C cable with magnetic charger
 - b. EUT powered by host PC via USB-C cable with magnetic charger
8. No spurious emissions were detected within 20dB of the limit below 30MHz.
9. The results recorded using the broadband antenna is known to correlate with the results obtained by using a tuned dipole with an acceptable degree of accuracy. The VSWR for the measurement antenna was found to be less than 2:1.
10. All modes of operation were investigated and the worst-case emissions are reported.

Sample Calculations

Determining Spurious Emissions Levels

- Field Strength Level $_{[dB\mu V/m]} = \text{Analyzer Level }_{[dBm]} + 107 + \text{AFCL }_{[dB/m]}$
- $\text{AFCL }_{[dB/m]} = (\text{Antenna Factor }_{[dB/m]} + \text{Cable Loss }_{[dB]} + \text{Attenuator }_{[dB]}) - \text{Preamplifier Gain }_{[dB]}$
- $\text{Margin }_{[dB]} = \text{Field Strength Level }_{[dB\mu V/m]} - \text{Limit }_{[dB\mu V/m]}$

FCC ID: BCG-A2473 IC: 579C-A2473	 PCTEST® Proud to be part of element	MEASUREMENT REPORT (CERTIFICATION)	Approved by: Quality Manager
Test Report S/N: 1C2106070041-08.BCG	Test Dates: 06/08/2021-08/06/2021	EUT Type: Watch	Page 53 of 63

7.7.1 Radiated Spurious Emissions (Below 960MHz) §15.209; RSS-Gen [8.9]

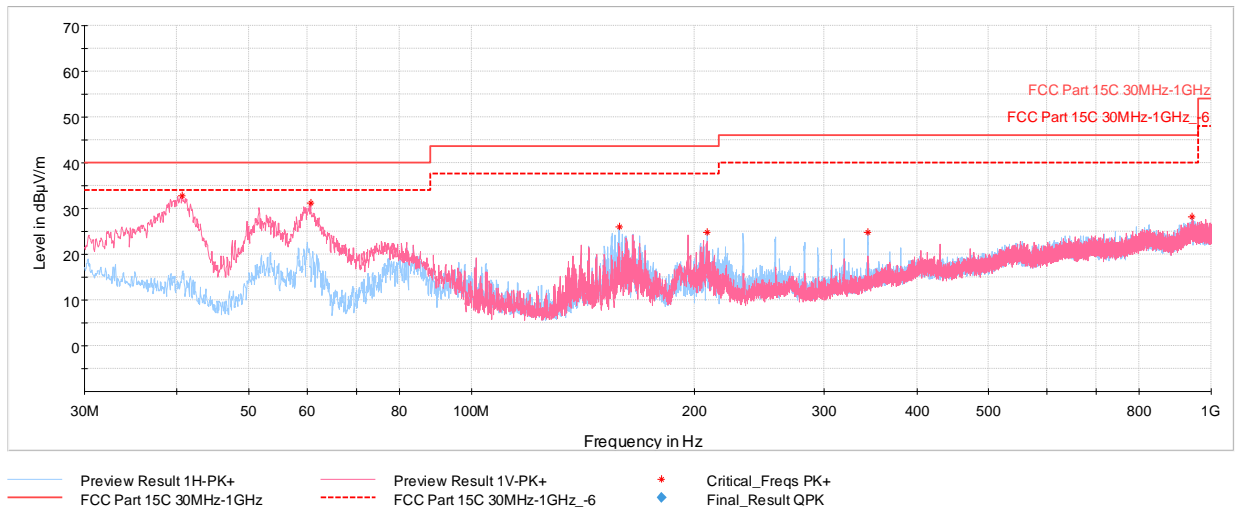

Plot 7-42. Radiated Spurious Emission 30-960MHz (Ch. 5, Config 3, Payload 125 with AC/DC Adapter + Magnetic Charger)

Frequency [MHz]	Detector	Ant. Pol. [H/V]	Antenna Height [cm]	Turntable Azimuth [degree]	Analyzer Level [dBm]	AFCL [dB/m]	Field Strength [dBµV/m]	Limit [dBµV/m]	Margin [dB]
40.67	Max Peak	V	100	338	-58.53	-15.60	32.87	40.00	-7.13
60.65	Max Peak	V	100	199	-54.72	-21.03	31.25	40.00	-8.75
158.43	Max Peak	H	100	259	-64.30	-16.75	25.95	43.52	-17.57
208.38	Max Peak	H	100	135	-65.83	-16.42	24.75	43.52	-18.77
343.26	Max Peak	H	100	241	-70.05	-12.05	24.90	46.02	-21.12
943.35	Max Peak	H	100	268	-78.38	-0.50	28.12	46.02	-17.90

Table 7-24. Radiated Spurious Emission 30-960MHz (Ch. 5, Config 3, Payload 125 with AC/DC Adapter + Magnetic Charger)

FCC ID: BCG-A2473 IC: 579C-A2473		MEASUREMENT REPORT (CERTIFICATION)		Approved by: Quality Manager
Test Report S/N: 1C2106070041-08.BCG	Test Dates: 06/08/2021-08/06/2021	EUT Type: Watch		Page 54 of 63

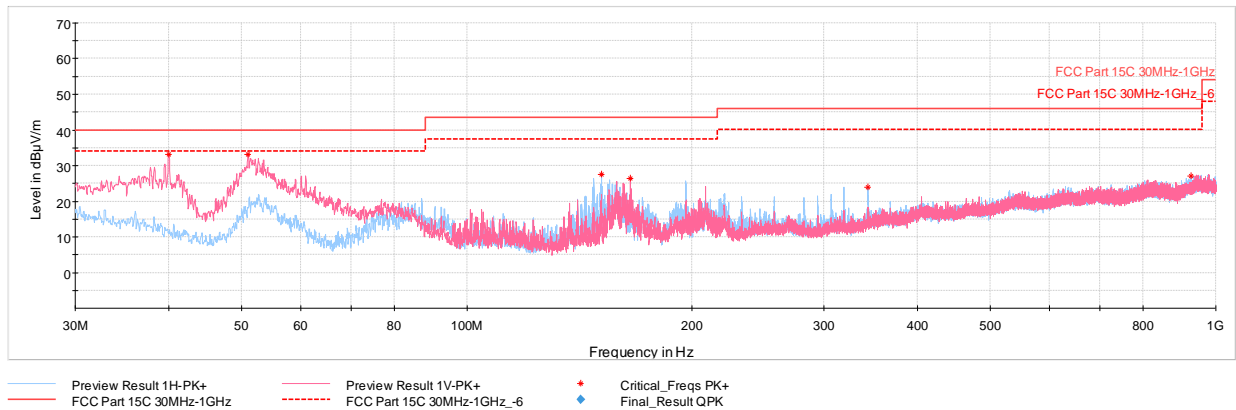

Plot 7-43. Radiated Spurious Emission 30-960MHz (Ch. 9, Config 3, Payload 125 with AC/DC Adapter + Magnetic Charger)

Frequency [MHz]	Detector	Ant. Pol. [H/V]	Antenna Height [cm]	Turntable Azimuth [degree]	Analyzer Level [dBm]	AFCL [dB/m]	Field Strength [dBµV/m]	Limit [dBµV/m]	Margin [dB]
39.99	Max Peak	V	100	0	-58.59	-15.26	33.15	40.00	-6.85
51.05	Max Peak	V	100	57	-53.70	-20.15	33.15	40.00	-6.85
151.30	Max Peak	H	250	251	-61.92	-17.66	27.42	43.52	-16.10
165.32	Max Peak	V	100	306	-63.44	-17.18	26.38	43.52	-17.14
343.21	Max Peak	H	100	244	-71.03	-12.06	23.91	46.02	-22.11
927.35	Max Peak	H	100	3	-79.01	-0.86	27.13	46.02	-18.89

Table 7-25. Radiated Spurious Emission 30-960MHz (Ch. 9, Config 3, Payload 125 with AC/DC Adapter + Magnetic Charger)

FCC ID: BCG-A2473 IC: 579C-A2473		MEASUREMENT REPORT (CERTIFICATION)	Approved by: Quality Manager
Test Report S/N: 1C2106070041-08.BCG	Test Dates: 06/08/2021-08/06/2021	EUT Type: Watch	Page 55 of 63

7.7.2 Simultaneous Tx Radiated Spurious Emissions (Below 960 MHz) \$15.209 & \$27.53(m); RSS-Gen [8.9] & RSS-199 [4.5]

Description	WLAN	UWB
Antenna	FCM	FCM
Channel	6	5
Operating Frequency (MHz)	2437	6500
Mode/Modulation	802.11b	Config 3/Payload125

Table 7-26. Worst Case Simultaneous Transmission Configuration

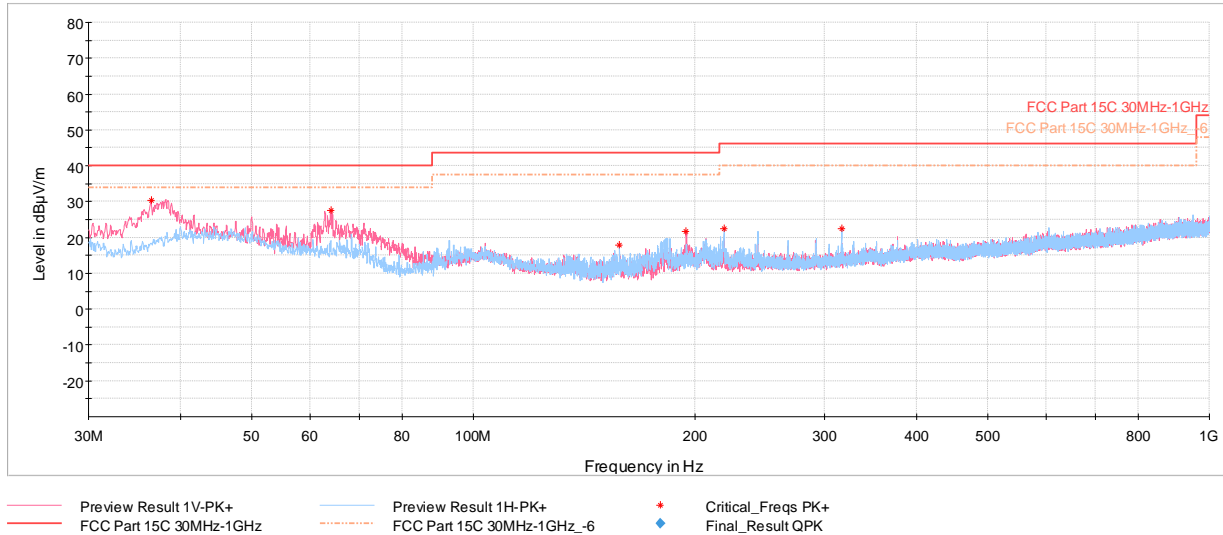

Plot 7-44. Radiated Spurious Emission – Simultaneous Transmission below 960 MHz with AC/DC Adapter + Magnetic Charger

Frequency [MHz]	Detector	Ant. Pol. [H/V]	Antenna Height [cm]	Turntable Azimuth [degree]	Analyzer Level [dBm]	AFCL [dB/m]	Field Strength [dBµV/m]	Limit [dBµV/m]	Margin [dB]
36.50	Max Peak	V	100	196	-61.21	-15.52	30.27	40.00	-9.73
64.00	Max Peak	V	100	205	-63.32	-16.11	27.57	40.00	-12.43
158.04	Max Peak	H	250	200	-71.00	-18.00	18.00	43.52	-25.52
194.56	Max Peak	V	100	334	-70.14	-15.26	21.60	43.52	-21.92
219.05	Max Peak	H	100	118	-69.38	-15.07	22.55	46.02	-23.47
316.34	Max Peak	H	100	81	-72.23	-12.24	22.53	46.02	-23.49

Table 7-27. Radiated Spurious Emission – Simultaneous Transmission below 960 MHz with AC/DC Adapter + Magnetic Charger

FCC ID: BCG-A2473 IC: 579C-A2473		MEASUREMENT REPORT (CERTIFICATION)	Approved by: Quality Manager
Test Report S/N: 1C2106070041-08.BCG	Test Dates: 06/08/2021-08/06/2021	EUT Type: Watch	Page 56 of 63

7.8 AC Line-Conducted Emission Measurement

§15.207; RSS-Gen [8.8]

Test Overview and Limit

All AC line conducted spurious emissions are measured with a receiver connected to a grounded LISN while the EUT is operating at its maximum duty cycle, at maximum power, and at the appropriate frequencies. All data rates and modes were investigated for AC Line conducted spurious emissions. Only the conducted emissions of the configuration that produced the worst case emissions are reported in this section.

All conducted emissions must not exceed the limits shown in the table below, per Section 15.207 and RSS-Gen (8.8).

Frequency of emission (MHz)	Conducted Limit (dB μ V)	
	Quasi-peak	Average
0.15 – 0.5	66 to 56*	56 to 46*
0.5 – 5	56	46
5 – 30	60	50

Table 7-28. Conducted Limits

*Decreases with the logarithm of the frequency.

Test Procedures Used

ANSI C63.10-2013, Section 6.2

Test Settings

Quasi-Peak Measurements

1. Analyzer center frequency was set to the frequency of the spurious emission of interest
2. RBW = 9kHz (for emissions from 150kHz – 30MHz)
3. Detector = quasi-peak
4. Sweep time = auto couple
5. Trace mode = max hold
6. Trace was allowed to stabilize

Average Measurements

1. Analyzer center frequency was set to the frequency of the spurious emission of interest
2. RBW = 9kHz (for emissions from 150kHz – 30MHz)
3. Detector = RMS
4. Sweep time = auto couple
5. Trace mode = max hold
6. Trace was allowed to stabilize

FCC ID: BCG-A2473 IC: 579C-A2473		MEASUREMENT REPORT (CERTIFICATION)	Approved by: Quality Manager
Test Report S/N: 1C2106070041-08.BCG	Test Dates: 06/08/2021-08/06/2021	EUT Type: Watch	Page 57 of 63

Test Setup

The EUT and measurement equipment were set up as shown in the diagram below.

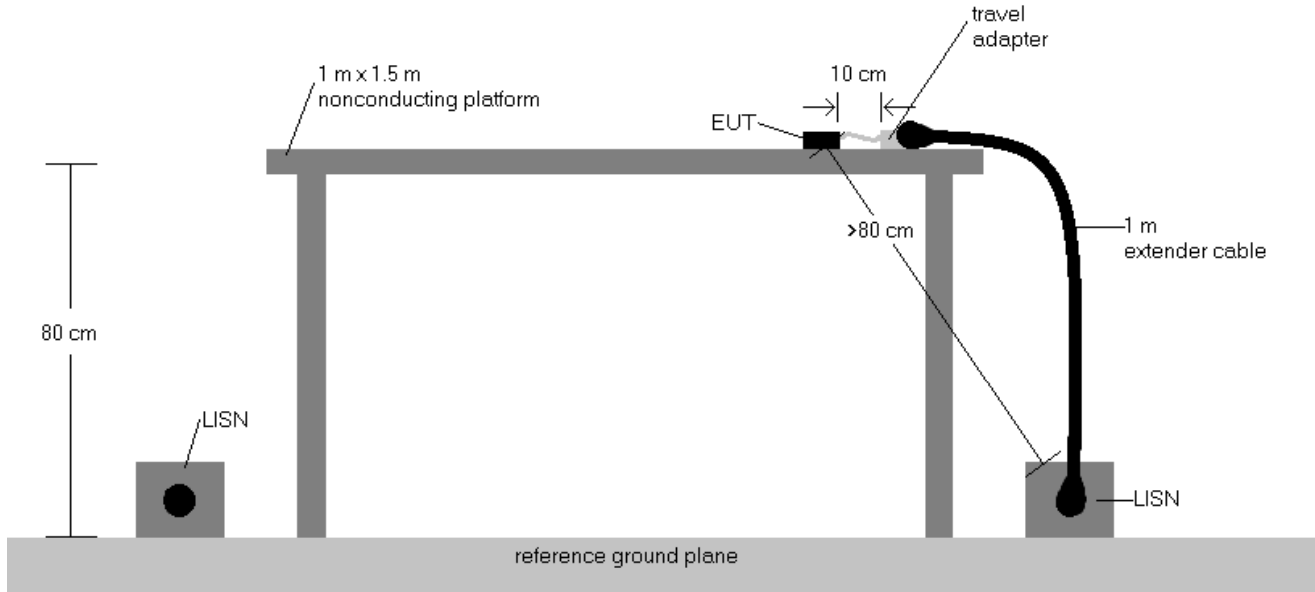
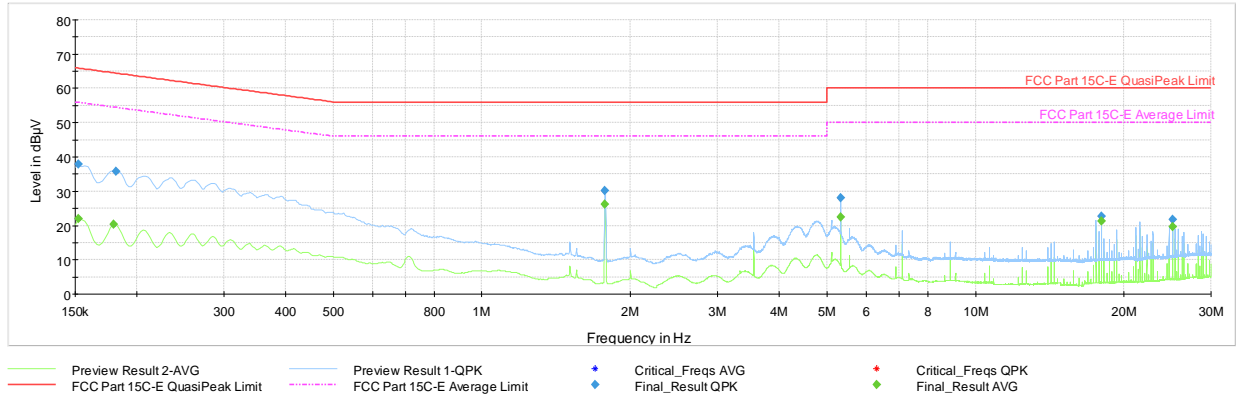

Figure 7-8. Test Instrument & Measurement Setup

Test Notes

1. All modes of operation were investigated and the worst-case emissions are reported. The emissions found were not affected by the choice of channel used during testing.
2. The limit for an intentional radiator from 150kHz to 30MHz are specified in Part 15.207 and RSS-Gen (8.8).
3. $\text{Corr. (dB)} = \text{Cable loss (dB)} + \text{LISN insertion factor (dB)}$
4. $\text{QP/AV Level (dB}\mu\text{V)} = \text{QP/AV Analyzer/Receiver Level (dB}\mu\text{V)} + \text{Corr. (dB)}$
5. $\text{Margin (dB)} = \text{QP/AV Level (dB}\mu\text{V)} - \text{QP/AV Limit (dB}\mu\text{V)}$
6. Traces shown in plot are made using a quasi-peak and average detectors
7. Both configurations below were investigated, and the worst case has been reported.
 - a. EUT powered by AC/DC adapter via USB-C cable with magnetic charger
 - b. EUT powered by host PC via USB-C cable with magnetic charger
8. Deviations to the Specifications: None.

FCC ID: BCG-A2473 IC: 579C-A2473	 PCTEST [®] Proud to be part of element	MEASUREMENT REPORT (CERTIFICATION)	Approved by: Quality Manager
Test Report S/N: 1C2106070041-08.BCG	Test Dates: 06/08/2021-08/06/2021	EUT Type: Watch	Page 58 of 63



Plot 7-45. AC Line Conducted (Ch. 5, Config 3, Payload 125 L1, with AC/DC Adapter + Magnetic Charger)

Frequency [MHz]	Process State	QuasiPeak [dBµV]	Average [dBµV]	Limit [dBµV]	Margin [dB]	Line	PE
0.152	FINAL	37.8	—	65.88	-28.08	L1	GND
0.152	FINAL	—	22.04	55.88	-33.83	L1	GND
0.179	FINAL	—	20.29	54.52	-34.23	L1	GND
0.182	FINAL	35.9	—	64.42	-28.51	L1	GND
1.777	FINAL	30.1	—	56.00	-25.90	L1	GND
1.777	FINAL	—	26.27	46.00	-19.73	L1	GND
5.334	FINAL	—	22.35	50.00	-27.65	L1	GND
5.334	FINAL	28.2	—	60.00	-31.82	L1	GND
17.999	FINAL	—	21.22	50.00	-28.78	L1	GND
17.999	FINAL	22.6	—	60.00	-37.43	L1	GND
25.112	FINAL	21.7	—	60.00	-38.34	L1	GND
25.112	FINAL	—	19.74	50.00	-30.26	L1	GND

Table 7-29. AC Line Conducted Data (Ch. 5, Config 3, Payload 125 L1, with AC/DC Adapter + Magnetic Charger)

FCC ID: BCG-A2473 IC: 579C-A2473		MEASUREMENT REPORT (CERTIFICATION)	Approved by: Quality Manager
Test Report S/N: 1C2106070041-08.BCG	Test Dates: 06/08/2021-08/06/2021	EUT Type: Watch	Page 59 of 63

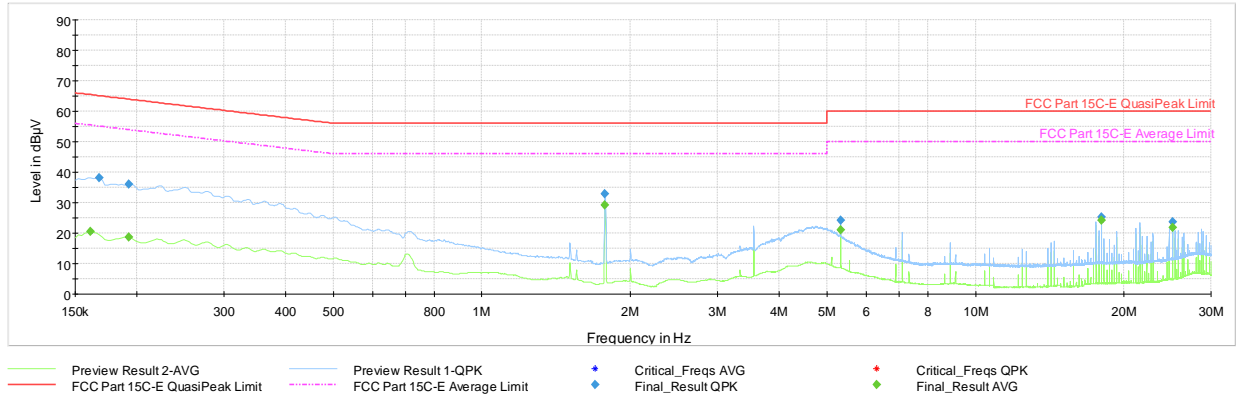

Plot 7-46. AC Line Conducted (Ch. 5, Config 3, Payload 125 N, with AC/DC Adapter + Magnetic Charger)

Frequency [MHz]	Process State	QuasiPeak [dBµV]	Average [dBµV]	Limit [dBµV]	Margin [dB]	Line	PE
0.161	FINAL	—	20.63	55.40	-34.77	N	GND
0.168	FINAL	38.2	—	65.06	-26.88	N	GND
0.193	FINAL	36.1	—	63.92	-27.86	N	GND
0.193	FINAL	—	18.68	53.92	-35.24	N	GND
1.777	FINAL	32.9	—	56.00	-23.13	N	GND
1.777	FINAL	—	29.18	46.00	-16.82	N	GND
5.334	FINAL	—	21.17	50.00	-28.83	N	GND
5.334	FINAL	24.2	—	60.00	-35.85	N	GND
17.999	FINAL	—	24.30	50.00	-25.70	N	GND
17.999	FINAL	25.2	—	60.00	-34.85	N	GND
25.112	FINAL	23.7	—	60.00	-36.29	N	GND
25.112	FINAL	—	21.95	50.00	-28.05	N	GND

Table 7-30. AC Line Conducted Data (Ch. 5, Config 3, Payload 125 N, with AC/DC Adapter + Magnetic Charger)

FCC ID: BCG-A2473 IC: 579C-A2473		MEASUREMENT REPORT (CERTIFICATION)	Approved by: Quality Manager
Test Report S/N: 1C2106070041-08.BCG	Test Dates: 06/08/2021-08/06/2021	EUT Type: Watch	Page 60 of 63

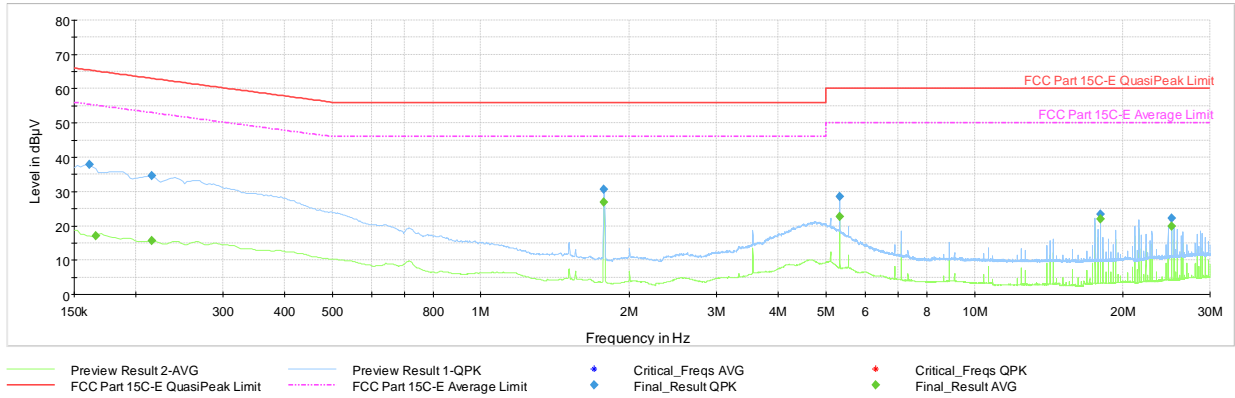

Plot 7-47. AC Line Conducted (Ch. 9, Config 3, Payload 125 L1, with AC/DC Adapter + Magnetic Charger)

Frequency [MHz]	Process State	QuasiPeak [dBµV]	Average [dBµV]	Limit [dBµV]	Margin [dB]	Line	PE
0.161	FINAL	37.8	—	65.40	-27.57	L1	GND
0.166	FINAL	—	17.10	55.17	-38.07	L1	GND
0.215	FINAL	34.5	—	63.00	-28.50	L1	GND
0.215	FINAL	—	15.72	53.00	-37.28	L1	GND
1.777	FINAL	30.6	—	56.00	-25.36	L1	GND
1.777	FINAL	—	26.92	46.00	-19.08	L1	GND
5.334	FINAL	—	22.68	50.00	-27.32	L1	GND
5.334	FINAL	28.6	—	60.00	-31.41	L1	GND
17.999	FINAL	—	22.06	50.00	-27.94	L1	GND
17.999	FINAL	23.3	—	60.00	-36.72	L1	GND
25.112	FINAL	22.3	—	60.00	-37.74	L1	GND
25.112	FINAL	—	19.83	50.00	-30.17	L1	GND

Table 7-31. AC Line Conducted Data (Ch. 9, Config 3, Payload 125 L1, with AC/DC Adapter + Magnetic Charger)

FCC ID: BCG-A2473 IC: 579C-A2473		MEASUREMENT REPORT (CERTIFICATION)	Approved by: Quality Manager
Test Report S/N: 1C2106070041-08.BCG	Test Dates: 06/08/2021-08/06/2021	EUT Type: Watch	Page 61 of 63

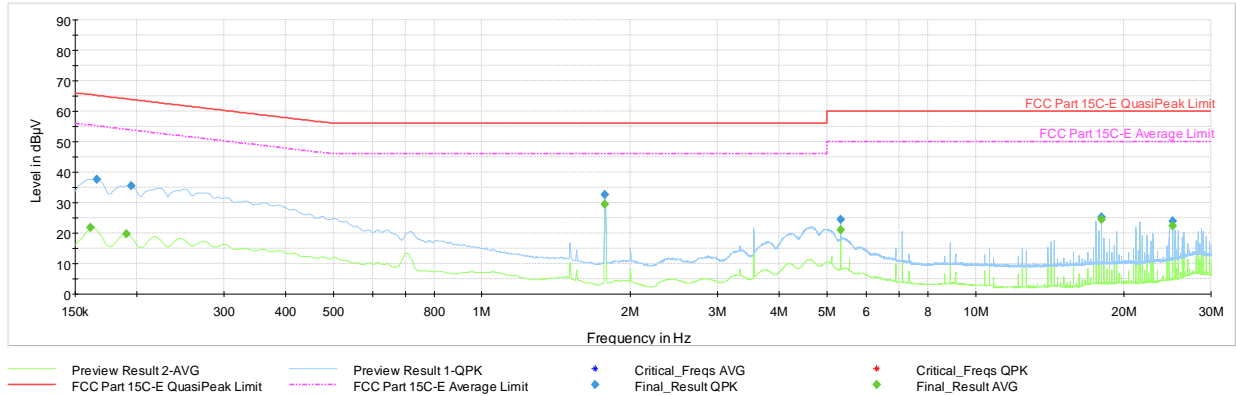

Plot 7-48. AC Line Conducted Plot (Ch. 9, Config 3, Payload 125 N, with AC/DC Adapter + Magnetic Charger)

Frequency [MHz]	Process State	QuasiPeak [dBµV]	Average [dBµV]	Limit [dBµV]	Margin [dB]	Line	PE
0.161	FINAL	—	21.85	55.40	-33.55	N	GND
0.166	FINAL	37.7	—	65.17	-27.46	N	GND
0.191	FINAL	—	19.85	54.02	-34.16	N	GND
0.195	FINAL	35.5	—	63.82	-28.34	N	GND
1.777	FINAL	32.8	—	56.00	-23.24	N	GND
1.777	FINAL	—	29.52	46.00	-16.48	N	GND
5.334	FINAL	—	21.09	50.00	-28.91	N	GND
5.334	FINAL	24.4	—	60.00	-35.64	N	GND
17.999	FINAL	—	24.55	50.00	-25.45	N	GND
17.999	FINAL	25.4	—	60.00	-34.62	N	GND
25.112	FINAL	24.0	—	60.00	-36.04	N	GND
25.112	FINAL	—	22.48	50.00	-27.52	N	GND

Table 7-32. AC Line Conducted Data (Ch. 9, Config 3, Payload 125 N, with AC/DC Adapter + Magnetic Charger)

FCC ID: BCG-A2473 IC: 579C-A2473		MEASUREMENT REPORT (CERTIFICATION)	Approved by: Quality Manager
Test Report S/N: 1C2106070041-08.BCG	Test Dates: 06/08/2021-08/06/2021	EUT Type: Watch	Page 62 of 63

8.0 CONCLUSION

The data collected relate only the item(s) tested and show that the **Apple Watch FCC ID: BCG-A2473** and **IC: 579C-A2473** is in compliance with Part 15 Subpart F (15.519) of the FCC Rules and RSS-220 of the Innovation, Science and Economic Development Canada Rules.

FCC ID: BCG-A2473 IC: 579C-A2473		MEASUREMENT REPORT (CERTIFICATION)	Approved by: Quality Manager
Test Report S/N: 1C2106070041-08.BCG	Test Dates: 06/08/2021-08/06/2021	EUT Type: Watch	Page 63 of 63