

8

2:1 view

7

6

5

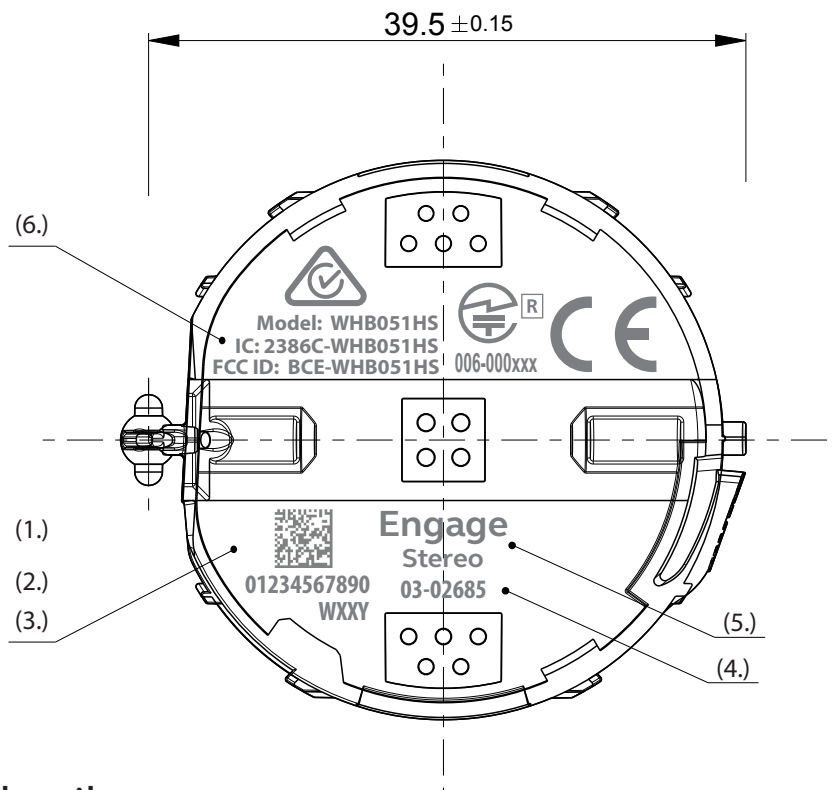

### Variable details:

4

- (1.) S/N shown in 2D matrix, size 4x4 mm;
- (2.) GN assign SN number;
- (3.) Capital letter "W" follow by week/year code, current production day. Font: Myriad Pro, 5pt.  
Year code using base36 coding. (i.e.: "W35H" for week 35 year 2017)
- (4.) "Stereo" & Unit number "03-02685": Myriad Pro, 5pt.
- (5.) Product Name "Engage": GN Elliot Bold, 7 pt.
- (6.) TA icons, minimal 5 mm height, text  $\geq$  4 pt, Myriad Pro

3

2

### CONFIDENTIALITY NOTICE:

This document is the property of GN A/S and must be treated as confidential. The document must not be used, or disclosed to any third party, without written permission of GN A/S. Copyright © 2007 GN A/S. All rights reserved.

Process control dimensions are marked:

IQC/OQC Characteristics for Evaluation:

# 1, 2

Date of Change:

Description of Change:

Responsible:

1



Matr. Spec: (See B.O.M.)

Matr. type:

3D file name:

Cosmetic Standard: GSC.ST.00002  
Part Marking: GSC.PR.00102

Issued by:

ECAI

Issued:

24.08.17

Drawing Scale:

2:1

Size:

A4

Approved by:

Date Approved:

Projection:



Description:

Laser Etch Instruction, Premium HS, Rio\_Stereo

Document No:

08-03330

Doc. Revision:

A

Units:

mm

Page No:

1 of 1

A

B

C

D

E

F