

FCC Test Report

Compliance with Canada Interference-Causing
Equipment Standard ICES-003

Product Name : Bluetooth Speakerphone

Model No. : PHS040Wa

Applicant : GN Audio A/S

Address : Lautrupbjerg 7, 2750 Ballerup, Denmark

Date of Receipt : 2019/12/06

Issued Date : 2019/12/19

Report No. : 19C0095R-ITUSP01V00

Report Version : V1.0



The test results relate only to the samples tested.

The test results shown in the test report are traceable to the national/international standard through the calibration of the equipment and evaluated measurement uncertainty herein.

This report must not be used to claim product endorsement by TAF or any agency of the government.

The test report shall not be reproduced without the written approval of DEKRA Testing and Certification Co., Ltd.

Test Report

Issued Date: 2019/12/19

Report No.: 19C0095R-ITUSP01V00



Product Name : Bluetooth Speakerphone
Applicant : GN Audio A/S
Address : Lautrupbjerg 7, 2750 Ballerup, Denmark
Manufacturer : GN Audio A/S
Model No. : PHS040Wa
EUT Rated Voltage : DC 3.8V
EUT Test Voltage : AC 120V / 60Hz
Trade Name : Jabra
Applicable Standard : FCC CFR Title 47 Part 15 Subpart B: 2018, Class B
CISPR 22: 2008, ANSI C63.4: 2014
ICES-003 Issue 6: 2016 Class B
Test Result : Complied
Performed Location : DEKRA Testing and Certification Co., Ltd.
Linkou Laboratory
No. 5-22, Ruishukeng
Linkou District, New Taipei City, 24451, Taiwan
TEL:+866-2-8601-3788 / FAX:+886-2-8601-3789

Documented By : Jessie Ciou
(Adm. Assistant / Jessie Ciou)
Reviewed By : Wright Tsai
(Engineer / Wright Tsai)
Approved By : [Signature]
(Director / Vincent Lin)

Laboratory Information

We, **DEKRA Testing and Certification Co., Ltd.**, are an independent EMC and safety consultancy that was established the whole facility in our laboratories. The test facility has been accredited/accepted (audited or listed) by the following related bodies in compliance with ISO 17025, EN 45001 and specified testing scopes:

Taiwan	:	BSMI, NCC, TAF
Norway	:	DNVGL
USA	:	FCC
Japan	:	VCCI

The address and introduction of DEKRA Testing and Certification Co., Ltd. laboratories can be founded in our Web site : <http://www.dekra.com.tw>

TABLE OF CONTENTS

Description	Page
1. General Information	5
1.1. EUT Description.....	5
1.2. Mode of Operation	6
1.3. Tested System Details	7
1.4. Configuration of Tested System	8
1.5. EUT Exercise Software.....	10
2. Technical Test	11
2.1. Summary of Test Result.....	11
2.2. List of Test Equipment	12
2.3. Measurement Uncertainty.....	13
2.4. Test Environment	14
3. Conducted Emission	15
3.1. Test Specification	15
3.2. Test Setup.....	15
3.3. Limit	15
3.4. Test Procedure.....	16
3.5. Test Result	17
3.6. Test Photograph.....	21
4. Radiated Emission	23
4.1. Test Specification	23
4.2. Test Setup.....	23
4.3. Limit	24
4.4. Test Procedure.....	25
4.5. Test Result	26
4.6. Test Photograph.....	34
5. Attachment.....	37
EUT Photograph.....	37

1. General Information

1.1. EUT Description

Product Name	Bluetooth Speakerphone
Trade Name	Jabra
Model No.	PHS040Wa
EUT Max Frequency	2.4GHz

1.2. Mode of Operation

DEKRA has verified the construction and function in typical operation. All the test modes were carried out with the EUT in normal operation, which was shown in this test report and defined as:

Pre-Test Mode	
Mode 1: BT + USB Dongle + Battery	
Mode 2: USB + Charge	
Final Test Mode	
Emission	Mode 1: BT + USB Dongle + Battery Mode 2: USB + Charge

1.3. Tested System Details

The types for all equipments, plus descriptions of all cables used in the tested system (including inserted cards) are:

Test Mode		Mode 1: BT + USB Dongle + Battery			
Product		Manufacturer	Model No.	Serial No.	Power Cord
1	Monitor	DELL	U2410f	CN-082WXD-72872-1A V-AD8L	N/A
2	Notebook PC	DELL	XPS	J0V3TY1	Non-Shielded, 0.8m
3	Printer	EPSON	StyLus C63	FAPY093574	Non-Shielded, 1.9m
4	Microphone & Earphone	RONEVER	MOE240	N/A	N/A
5	USB Mouse	Microsoft	1113	N/A	N/A
6	USB Dongle	END040W	N/A	N/A	N/A

Test Mode		Mode 2: USB + Charge			
Product		Manufacturer	Model No.	Serial No.	Power Cord
1	Monitor	DELL	U2410f	CN-082WXD-72872-1A V-AD8L	N/A
2	Notebook PC	DELL	XPS	J0V3TY1	Non-Shielded, 0.8m
3	Printer	EPSON	StyLus C63	FAPY093574	Non-Shielded, 1.9m
4	Microphone & Earphone	RONEVER	MOE240	N/A	N/A
5	USB Mouse	Microsoft	1113	N/A	N/A

1.4. Configuration of Tested System

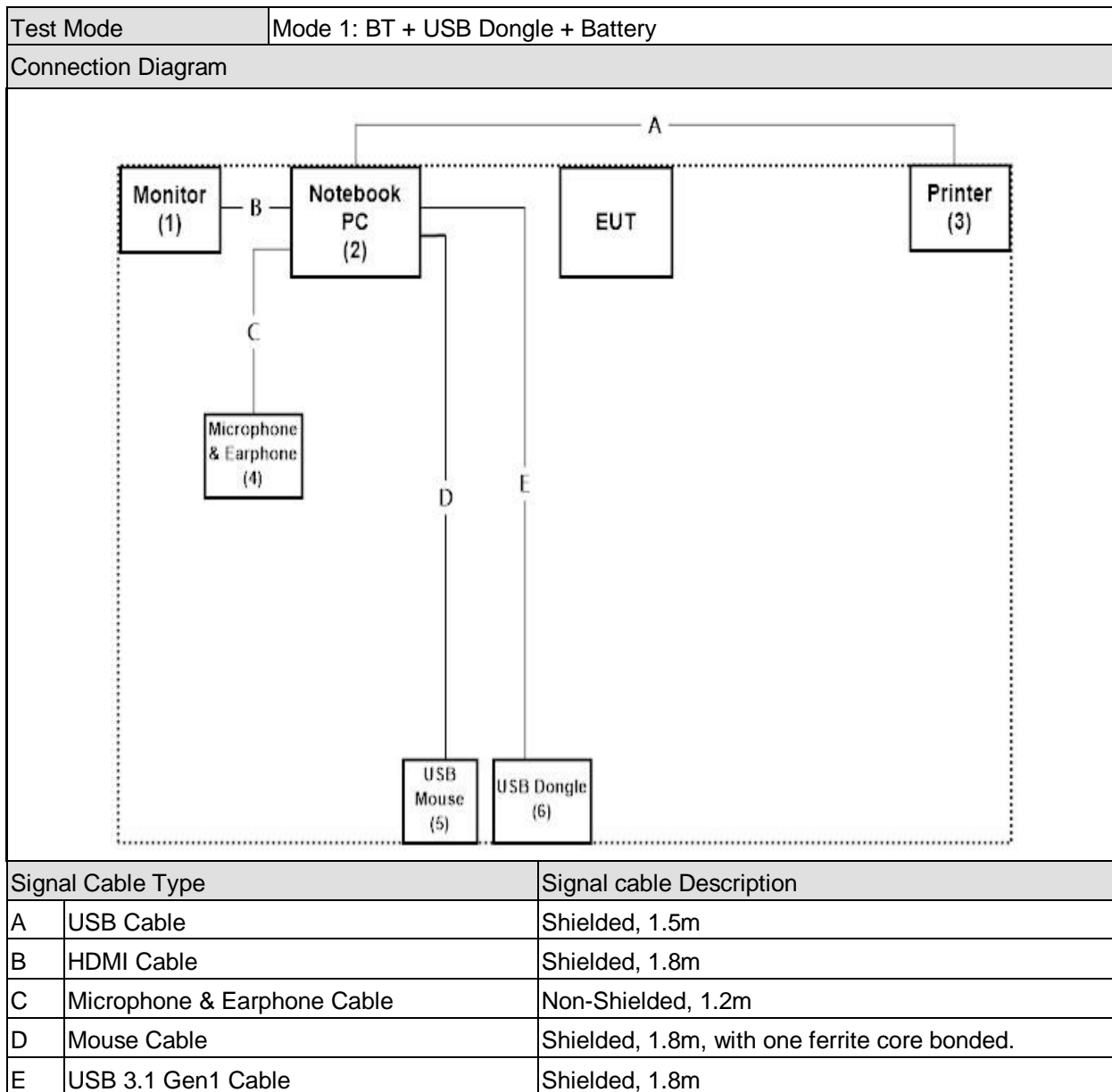

Note:

- Use Full system setup configuration determines Worst-Case Mode.
- Use 2dB law program determines Max. Cable Configuration and Worst-Case Mode.
- Radiated emission item test: Performed using the Horn Antenna 3dB Beamwidth to 3m from the EUT size sufficient to cover the procedure.
- Radiated emission item test: Performed using the Horn Antenna 3dB Beamwidth non 3m distance sufficient to cover the size of the EUT program.

Test Mode	Mode 2: USB + Charge
-----------	----------------------

Connection Diagram

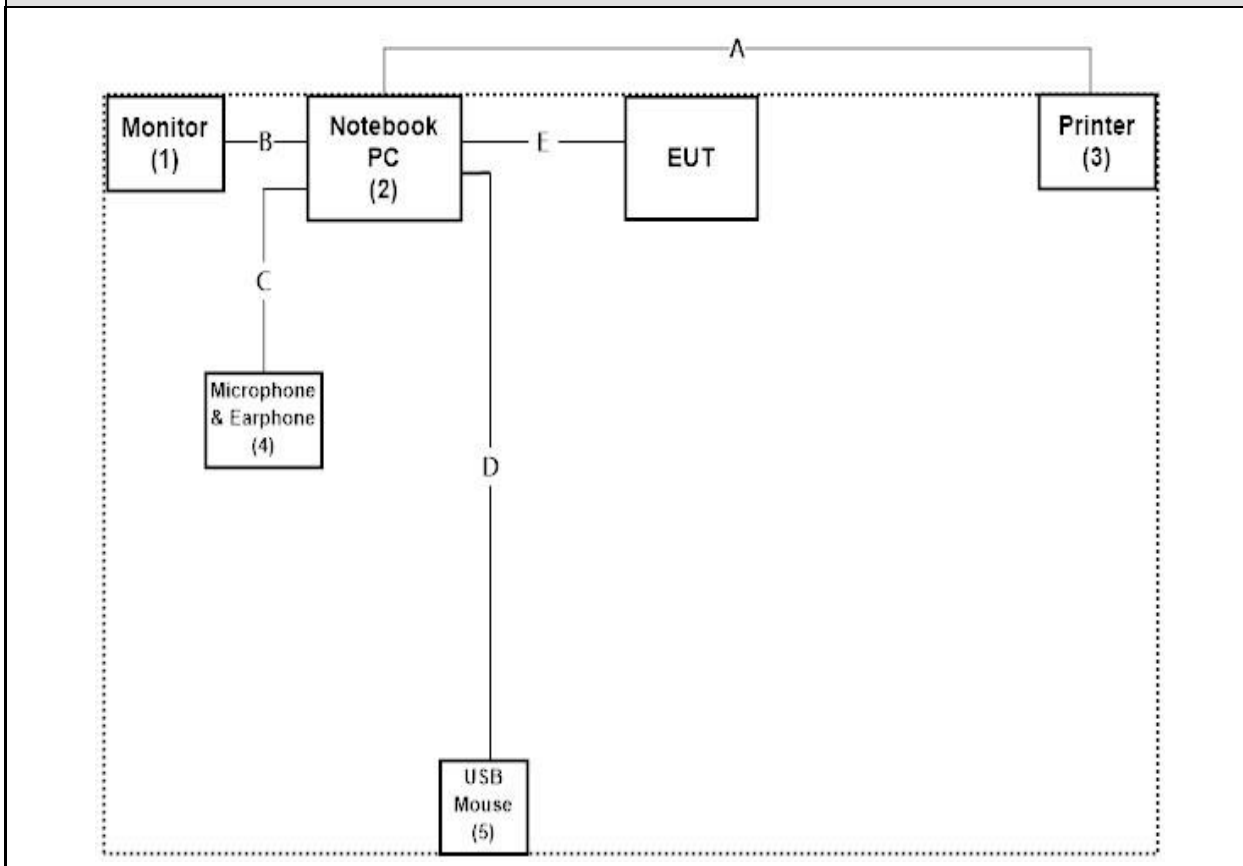

Signal Cable Type	Signal cable Description
A	USB Cable Shielded, 1.5m
B	HDMI Cable Shielded, 1.8m
C	Microphone & Earphone Cable Non-Shielded, 1.2m
D	Mouse Cable Shielded, 1.8m, with one ferrite core bonded.
E	USB 2.0 Cable Shielded, 1.0m

Note:

- Use Full system setup configuration determines Worst-Case Mode.
- Use 2dB law program determines Max. Cable Configuration and Worst-Case Mode.
- Radiated emission item test: Performed using the Horn Antenna 3dB Beamwidth to 3m from the EUT size sufficient to cover the procedure.
- Radiated emission item test: Performed using the Horn Antenna 3dB Beamwidth non 3m distance sufficient to cover the size of the EUT program.

1.5. EUT Exercise Software

1	Setup the EUT and simulators as shown on 1.4.
2	Turn on the power of all equipment.
3	All the features of the EUT operation normally.

2. Technical Test

2.1. Summary of Test Result

- No deviations from the test standards
- Deviations from the test standards as below description:

Emission			
Performed Item	Normative References	Test Performed	Deviation
Conducted Emission	FCC CFR Title 47 Part 15 Subpart B: 2018, Class B ANSI C63.4: 2014	Yes	No
Radiated Emission	FCC CFR Title 47 Part 15 Subpart B: 2018, Class B ANSI C63.4: 2014	Yes	No

Note : Test Procedure ANSI C63.4:2014 MP-5:1986

2.2. List of Test Equipment

Conducted Emission / SR1

Instrument	Manufacturer	Type No.	Serial No	Cal. Date
EMI Test Receiver	R&S	ESR3	102187	2019/05/13
LISN	Schwarzback	8226	176	2019/05/16
LISN	Schwarzback	8226	177	2019/05/16
LISN	R&S	ESH2-Z5	836679/023	2019/03/11
Coaxial Cable	DEKRA	RG 400	LC016-RG	2019/06/20

Note:Test Receiver Detector:Quasipeak and Average Bandwidth:9KHz

Radiated Emission / Site4

Instrument	Manufacturer	Type No.	Serial No	Cal. Date
Broadband Antenna	Schwarzbeck	VULB 9168	1054	2019/11/18
EMI Test Receiver	R&S	ESCS 30	825442/018	2019/03/04
Coaxial Cable	DEKRA	RG 214	LC004-RG	2019/06/14
Pre-Amplifier	Jet-Power	JPA-10M1G33	170101000330011	2019/06/14
Coaxial signal switch	Anritsu	MP59B	6201415887	2019/06/14
Site4 NSA	DEKRA	N/A	N/A	2019/06/14

Note:Test Receiver Detector:Quasipeak Bandwidth:120KHz

Radiated Emission / CB7

Instrument	Manufacturer	Type No.	Serial No	Cal. Date
EMI Test Receiver	R&S	ESU26	100433	2019/11/11
Horn Antenna	ETS-Lindgren	3117	00202819	2019/04/24
Horn Antenna	SCHWARZBECK	9120D	576	2019/12/18
Pre-Amplifier	EMCI	EMC051845SE	980359	2019/11/08
CB7 VSWR	DEKRA	N/A	N/A	2019/06/24

2.3. Measurement Uncertainty

Conducted Emission

The measurement uncertainty is evaluated as ± 3.44 dB.

Radiated Emission

The measurement uncertainty is evaluated as ± 4.22 dB.

Radiated Emission Above 1GHz

The measurement uncertainty is evaluated as ± 5.08 dB.

2.4. Test Environment

Performed Item	Items	Required
Conducted Emission	Temperature (°C)	10-40
	Humidity (%RH)	10-90
Radiated Emission	Temperature (°C)	10-40
	Humidity (%RH)	10-90

3. Conducted Emission

3.1. Test Specification

According to Standard : FCC Part 15 Subpart B, ANSI C63.4

3.2. Test Setup

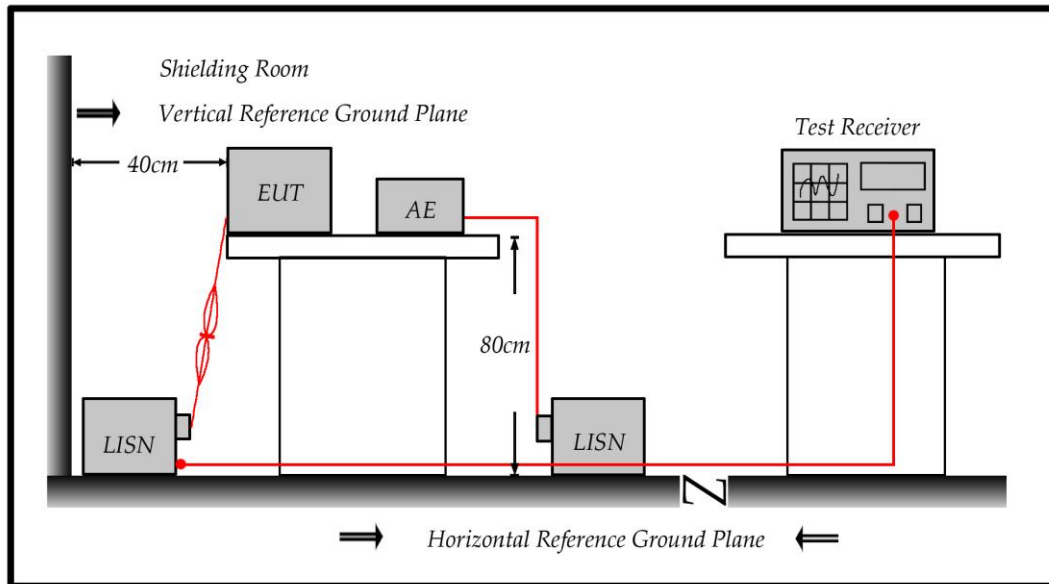

3.3. Limit

Limits		
Frequency (MHz)	QP (dBuV)	AV (dBuV)
0.15 - 0.50	66 - 56	56 - 46
0.50-5.0	56	46
5.0 - 30	60	50

Remarks: In the above table, the tighter limit applies at the band edges.

3.4. Test Procedure

The EUT and simulators are connected to the main power through a line impedance stabilization network (L.I.S.N.). This provides a 50 ohm /50uH coupling impedance for the measuring equipment. The peripheral devices are also connected to the main power through a LISN that provides a 50ohm/50uH coupling impedance with 50ohm termination.

(Please refers to the block diagram of the test setup and photographs.)

Both sides of A.C. line are checked for maximum conducted interference. In order to find the maximum emission, the relative positions of equipment and all of the interface cables must be changed on conducted measurement.

Conducted emissions were investigated over the frequency range from 0.15MHz to 30MHz using a receiver bandwidth of 9kHz.

3.5. Test Result

Site :	SR1	Engineer :	Aby
EUT	Bluetooth Speakerphone	Test Date :	2019/12/6
Test Voltage :	AC 120V/60Hz	Phase :	L1
Test Mode :	Mode 1		
Environmental Condition:	Temperature (°C) : 20.5 ; Relative Humidity (%RH) : 50		

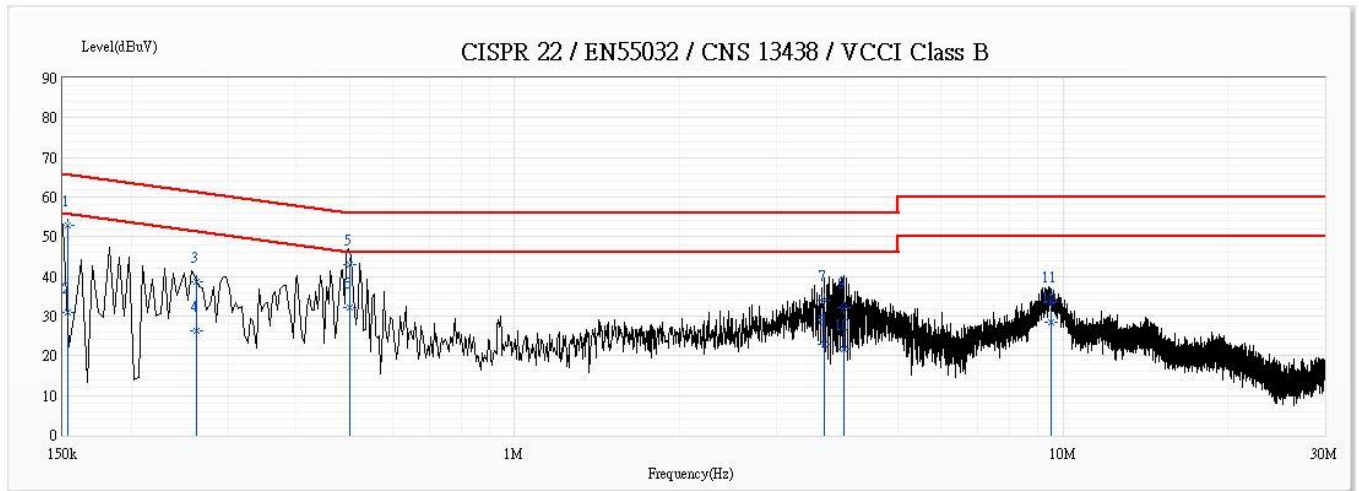

No	Frequency (MHz)	Emission Level (dBuV)	Limit (dBuV)	Margin (dB)	Reading Level (dBuV)	Correct Factor (dB)	Detector Type
*1	0.153	52.96	65.84	-12.88	43.25	9.71	QP
2	0.153	31.02	55.84	-24.82	21.31	9.71	AV
3	0.263	38.69	61.35	-22.66	28.99	9.71	QP
4	0.263	26.31	51.35	-25.03	16.61	9.71	AV
5	0.5	43.07	56.01	-12.94	33.36	9.71	QP
6	0.5	32.07	46.01	-13.94	22.36	9.71	AV
7	3.671	34.13	56.00	-21.87	24.28	9.84	QP
8	3.671	22.83	46.00	-23.17	12.99	9.84	AV
9	3.993	32.29	56.00	-23.71	22.44	9.85	QP
10	3.993	21.72	46.00	-24.28	11.87	9.85	AV
11	9.492	33.82	60.00	-26.18	23.79	10.03	QP
12	9.492	28.52	50.00	-21.48	18.49	10.03	AV

Remark:

1. "*" means this data is the worst emission level; "!" means this data is over limit.
2. Emission Level=Reading Level + Correct Factor(Correct Factor=LISN Factor+Cable Loss).
3. Margin=Limit -Emission Level.

Site :	SR1	Engineer :	Aby
EUT	Bluetooth Speakerphone	Test Date :	2019/12/6
Test Voltage :	AC 120V/60Hz	Phase :	N
Test Mode :	Mode 1		
Environmental Condition:	Temperature (°C) : 20.5 ; Relative Humidity (%RH) : 50		

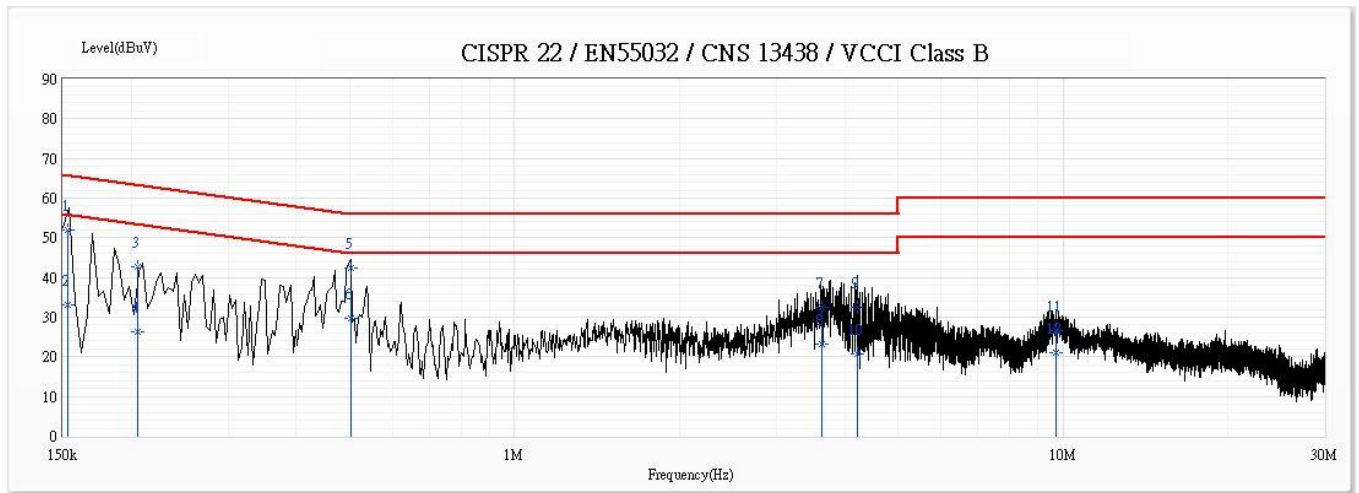

No	Frequency (MHz)	Emission Level (dBuV)	Limit (dBuV)	Margin (dB)	Reading Level (dBuV)	Correct Factor (dB)	Detector Type
1	0.153	51.84	65.82	-13.98	42.12	9.72	QP
2	0.153	32.95	55.82	-22.87	23.23	9.72	AV
3	0.206	42.74	63.37	-20.63	33.03	9.71	QP
4	0.206	26.38	53.37	-26.99	16.67	9.71	AV
*5	0.503	42.38	56.00	-13.62	32.66	9.72	QP
6	0.503	29.69	46.00	-16.31	19.97	9.72	AV
7	3.624	32.59	56.00	-23.41	22.74	9.85	QP
8	3.624	23.19	46.00	-22.81	13.34	9.85	AV
9	4.226	32.50	56.00	-23.50	22.63	9.87	QP
10	4.226	20.63	46.00	-25.37	10.76	9.87	AV
11	9.732	26.57	60.00	-33.43	16.50	10.07	QP
12	9.732	20.89	50.00	-29.11	10.82	10.07	AV

Remark:

1. "*" means this data is the worst emission level; "!" means this data is over limit.
2. Emission Level=Reading Level + Correct Factor(Correct Factor=LISN Factor+Cable Loss).
3. Margin=Limit -Emission Level.

Site :	SR1	Engineer :	Aby
EUT	Bluetooth Speakerphone	Test Date :	2019/12/6
Test Voltage :	AC 120V/60Hz	Phase :	L1
Test Mode :	Mode 2		
Environmental Condition:	Temperature (°C) : 20.5 ; Relative Humidity (%RH) : 50		

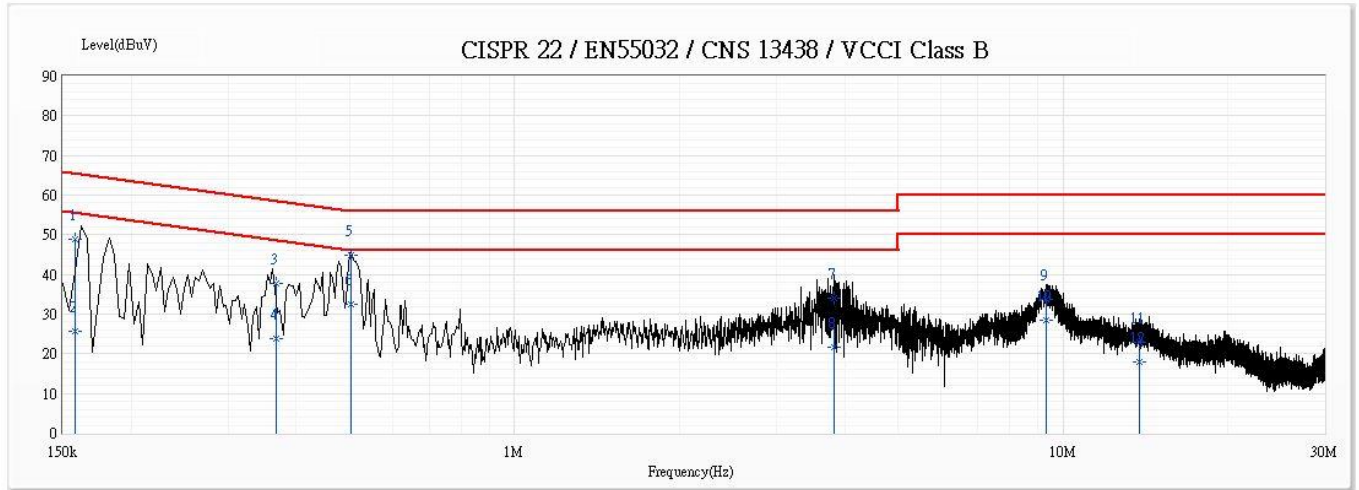

No	Frequency (MHz)	Emission Level (dBuV)	Limit (dBuV)	Margin (dB)	Reading Level (dBuV)	Correct Factor (dB)	Detector Type
1	0.158	48.98	65.55	-16.57	39.27	9.71	QP
2	0.158	25.75	55.55	-29.80	16.05	9.71	AV
3	0.367	37.80	58.57	-20.77	28.10	9.70	QP
4	0.367	23.82	48.57	-24.75	14.12	9.70	AV
*5	0.503	44.83	56.00	-11.17	35.12	9.71	QP
6	0.503	32.46	46.00	-13.54	22.75	9.71	AV
7	3.829	34.06	56.00	-21.94	24.22	9.85	QP
8	3.829	21.60	46.00	-24.40	11.75	9.85	AV
9	9.321	33.68	60.00	-26.32	23.65	10.03	QP
10	9.321	28.40	50.00	-21.60	18.37	10.03	AV
11	13.787	23.01	60.00	-36.99	12.87	10.14	QP
12	13.787	17.94	50.00	-32.06	7.80	10.14	AV

Remark:

1. "*" means this data is the worst emission level;"!" means this data is over limit.
2. Emission Level=Reading Level + Correct Factor(Correct Factor=LISN Factor+Cable Loss).
3. Margin=Limit -Emission Level.

Site :	SR1	Engineer :	Aby
EUT	Bluetooth Speakerphone	Test Date :	2019/12/6
Test Voltage :	AC 120V/60Hz	Phase :	N
Test Mode :	Mode 2		
Environmental Condition:	Temperature (°C) : 20.5 ; Relative Humidity (%RH) : 50		

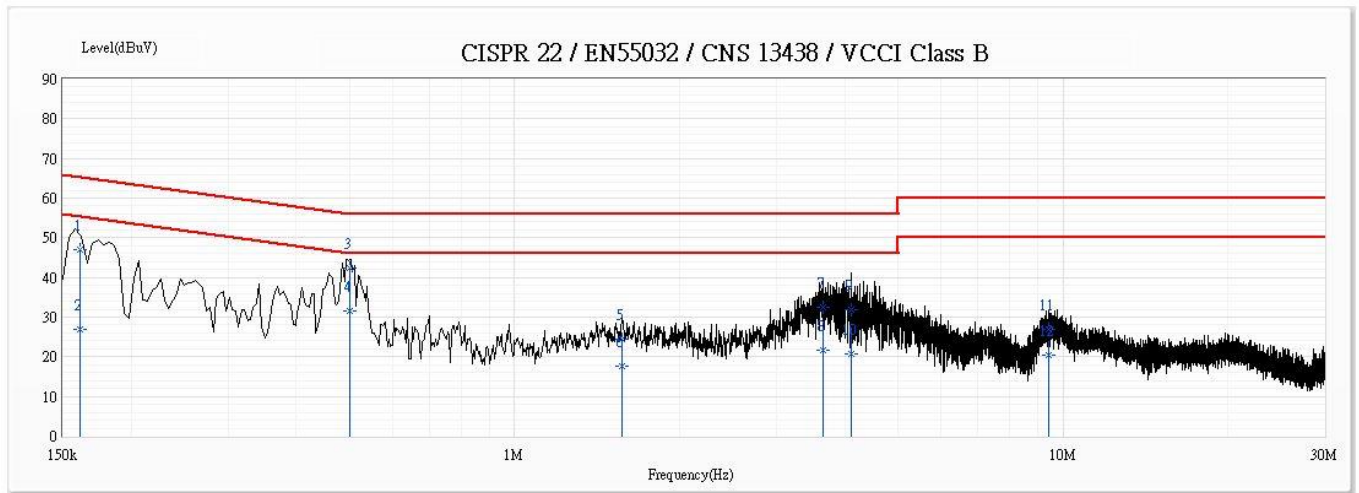

No	Frequency (MHz)	Emission Level (dBuV)	Limit (dBuV)	Margin (dB)	Reading Level (dBuV)	Correct Factor (dB)	Detector Type
1	0.161	46.88	65.41	-18.53	37.16	9.72	QP
2	0.161	26.79	55.41	-28.61	17.07	9.72	AV
*3	0.501	42.41	56.00	-13.59	32.69	9.72	QP
4	0.501	31.58	46.00	-14.42	21.86	9.72	AV
5	1.568	24.38	56.00	-31.62	14.61	9.77	QP
6	1.568	17.58	46.00	-28.42	7.81	9.77	AV
7	3.643	32.42	56.00	-23.58	22.57	9.85	QP
8	3.643	21.78	46.00	-24.22	11.93	9.85	AV
9	4.108	31.78	56.00	-24.22	21.92	9.87	QP
10	4.108	20.71	46.00	-25.29	10.84	9.87	AV
11	9.43	26.78	60.00	-33.22	16.72	10.06	QP
12	9.43	20.50	50.00	-29.50	10.44	10.06	AV

Remark:

1. "*" means this data is the worst emission level; "!" means this data is over limit.
2. Emission Level=Reading Level + Correct Factor(Correct Factor=LISN Factor+Cable Loss).
3. Margin=Limit -Emission Level.

3.6. Test Photograph

Test Mode : Mode 1: BT + USB Dongle + Battery

Description : Front View of Conducted Test



Test Mode : Mode 1: BT + USB Dongle + Battery

Description : Back View of Conducted Test

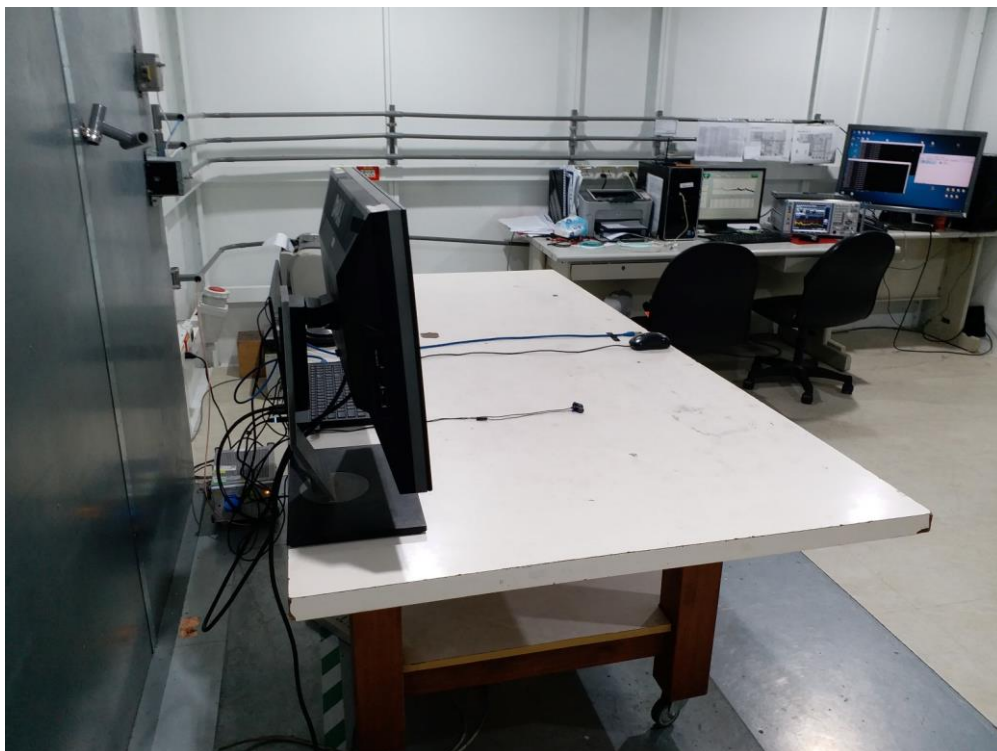

Test Mode : Mode 2: USB + Charge

Description : Front View of Conducted Test



Test Mode : Mode 2: USB + Charge

Description : Back View of Conducted Test

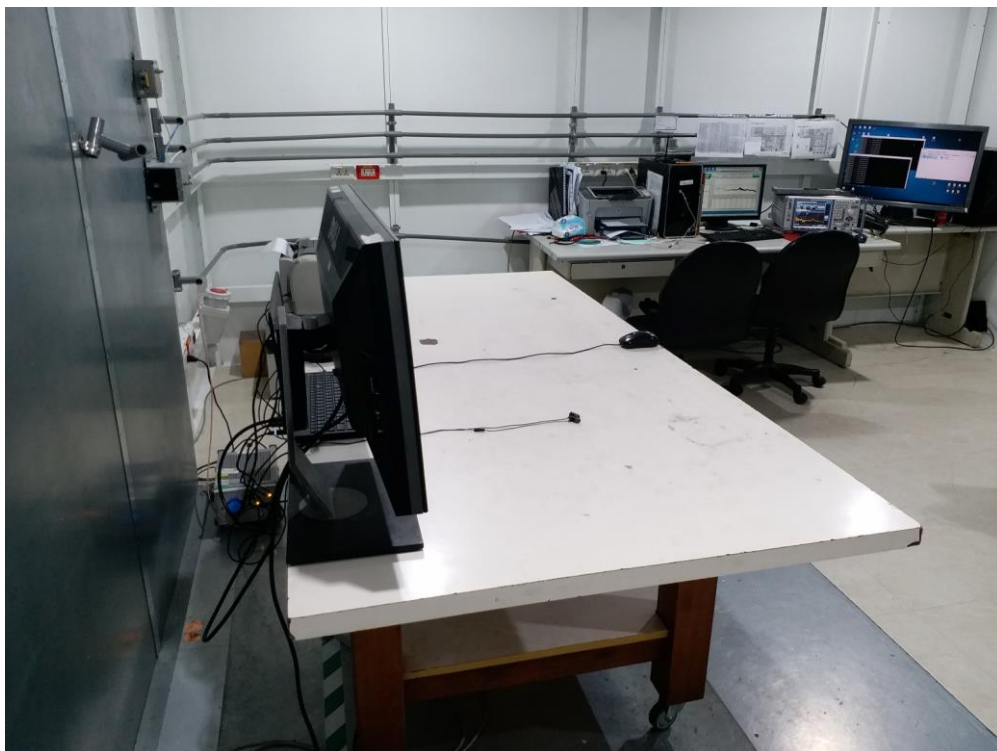

4. Radiated Emission

4.1. Test Specification

According to EMC Standard : FCC Part 15 Subpart B, ANSI C63.4

4.2. Test Setup

Under 1GHz Test Setup:

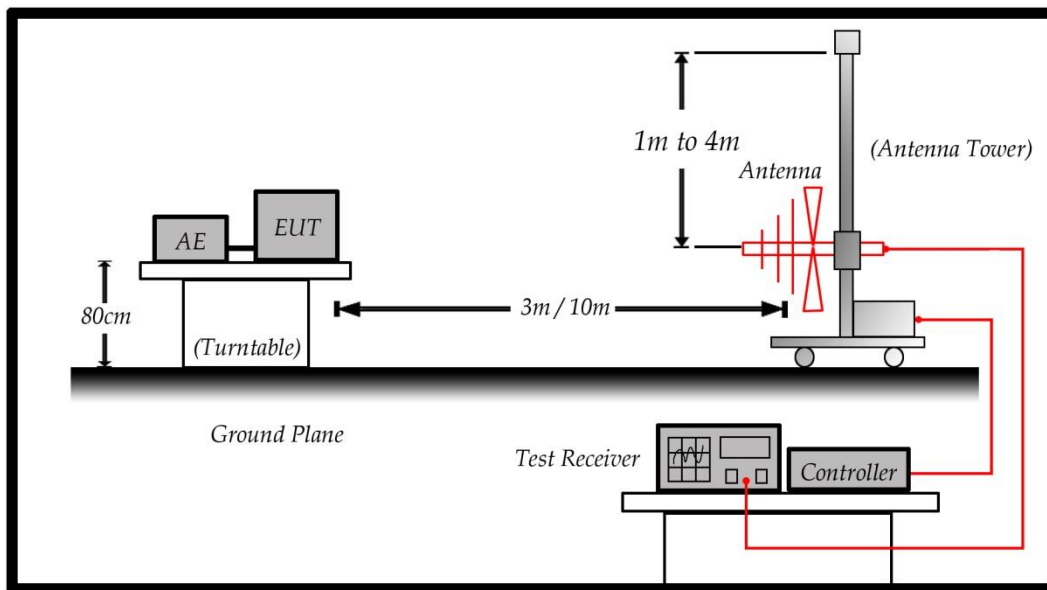

Above 1GHz Test Setup:

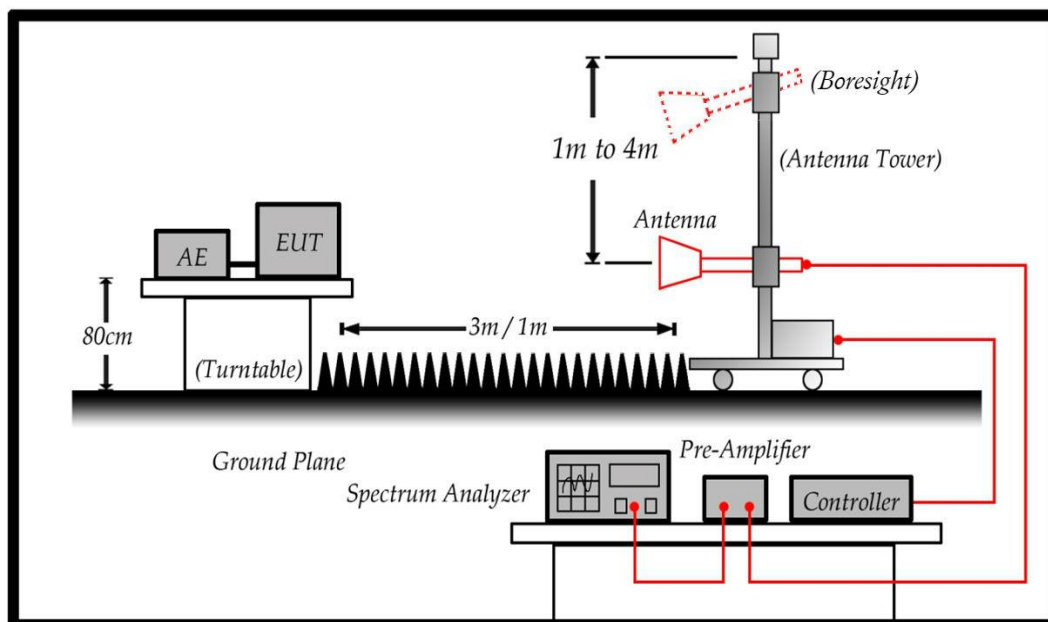

4.3. Limit

Under 1GHz test shall not exceed the following value:

Limits		
Frequency (MHz)	Distance (m)	dBuV/m
30 – 230	10	30
230 – 1000	10	37

Remark:

1. The tighter limit shall apply at the edge between two frequency bands.
2. Distance refers to the distance in meters between the measuring instrument antenna and the closed point of any part of the device or system.

Above 1GHz test shall not exceed the following value:

FCC Part 15 Subpart B Paragraph 15.109 Limits (dBuV/m)		
Frequency (MHz)	Distance (m)	dBuV/m
30-88	3	40
88-216	3	43.5
216-960	3	46
960-18000	3	54
Above 18000	1	63.54

Remark:

1. The tighter limit shall apply at the edge between two frequency bands.
2. Distance refers to the distance in meters between the measuring instrument antenna and the closed point of any part of the device or system.
3. RF Voltage (dBuV/m) = 20 log RF Voltage (uV/m)

4.4. Test Procedure

The EUT and its simulators are placed on a turn table which is 0.8 meter above ground.

The turn table can rotate 360 degrees to determine the position of the maximum emission level and the antenna (boresight antenna tower) can move up and down between 1 meter and 4 meters to find out the maximum emission level.

Both horizontal and vertical polarization of the antenna are set on measurement. In order to find the maximum emission, all of the interface cables must be manipulated on radiated measurement.

For an unintentional radiator, including a digital device, the spectrum shall be investigated from the lowest radio frequency signal generated or used in the device, without going below the lowest frequency for which a radiated emission limit is specified, up to the frequency shown in the following table:

Highest frequency generated or used in the device or on which the device operates or tunes (MHz)	Upper frequency of measurement range (MHz)
Below 1.705	30
1.705 – 108	1000
108 – 500	2000
500 – 1000	5000
Above 1000	5 th harmonic of the highest frequency or 40 GHz, whichever is lower

On any frequency or frequencies below or equal to 1000 MHz, the radiated limits shown are based on measuring equipment employing a quasi-peak detector function and above 1000 MHz, the radiated limits shown are based measuring equipment employing an average detector function.

When average radiated emission measurement are included emission measurement Above 1000 MHz, there also is a limit on the radio frequency emissions, as measured using instrumentation with a peak detector function, corresponding to 20 dB above the maximum permitted average limit.

For class A, the measurement distance between the EUT and antenna is 10 meters for under 1GHz and above 1GHz.

For class B, the measurement distance between the EUT and antenna is 10 meters for under 1GHz and 3 meters for above 1GHz.

The bandwidth below 1GHz setting on the field strength meter (Test Receiver) is 120 kHz and above 1GHz is 1MHz.

4.5. Test Result

Site :	SITE4	Engineer :	Don
EUT	Bluetooth Speakerphone	Test Date :	2019/12/9
Test Voltage :	By Battery	Polarity :	Horizontal
Test Mode :	Mode1		
Environmental Condition:	Temperature (°C) : 20.1 ; Relative Humidity (%RH) : 66		

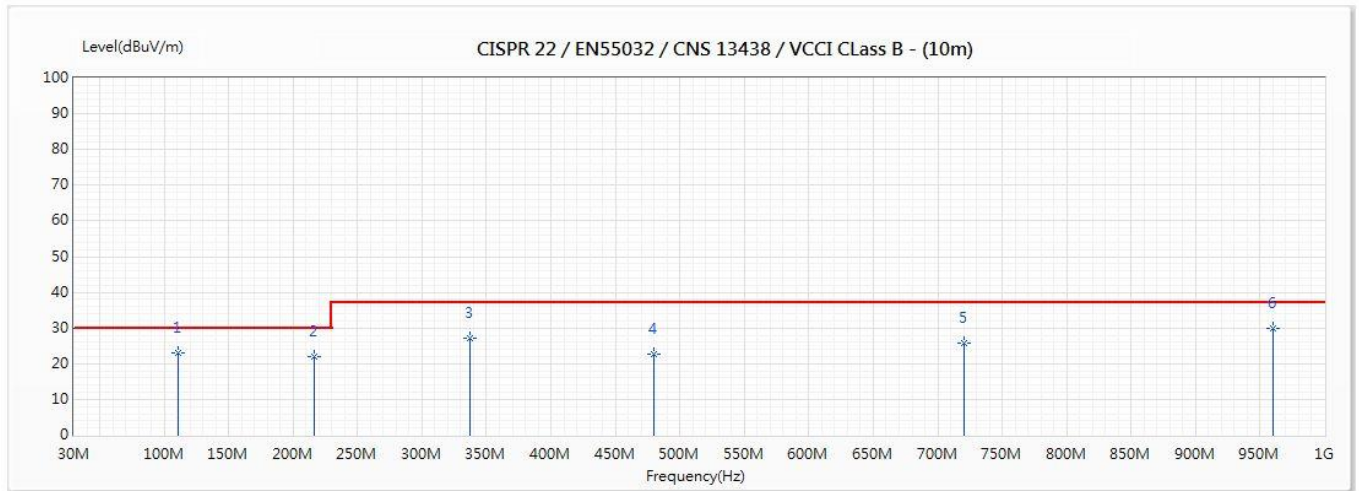

No	Frequency (MHz)	Emission Level (dBuV/m)	Limit (dBuV/m)	Margin (dB)	Reading Level (dBuV)	Correct Factor (dB/m)	Ant Pos (cm)	TT Pos (deg)	Detector Type
* 1	111	22.87	30.00	-7.13	36.31	-13.44	380	-81	QP
2	216	21.92	30.00	-8.08	34.30	-12.38	380	182	QP
3	337.01	27.17	37.00	-9.83	34.31	-7.14	300	192	QP
4	480	22.76	37.00	-14.24	25.60	-2.84	200	8	QP
5	720	25.61	37.00	-11.39	22.20	3.41	100	143	QP
6	960	29.82	37.00	-7.18	21.30	8.52	100	-78	QP

Remark:

1. "*" means this data is the worst emission level; "!" means this data is over limit.
2. Emission Level=Reading Level + Correct Factor(Correct Factor=Ant Factor+Cable Loss-Pre Amp).
3. Margin=Limit -Emission Level.

Site :	SITE4	Engineer :	Don
EUT	Bluetooth Speakerphone	Test Date :	2019/12/9
Test Voltage :	By Battery	Polarity :	Vertical
Test Mode :	Mode1,		
Environmental Condition:	Temperature (°C) : 20.1 ; Relative Humidity (%RH) : 66		

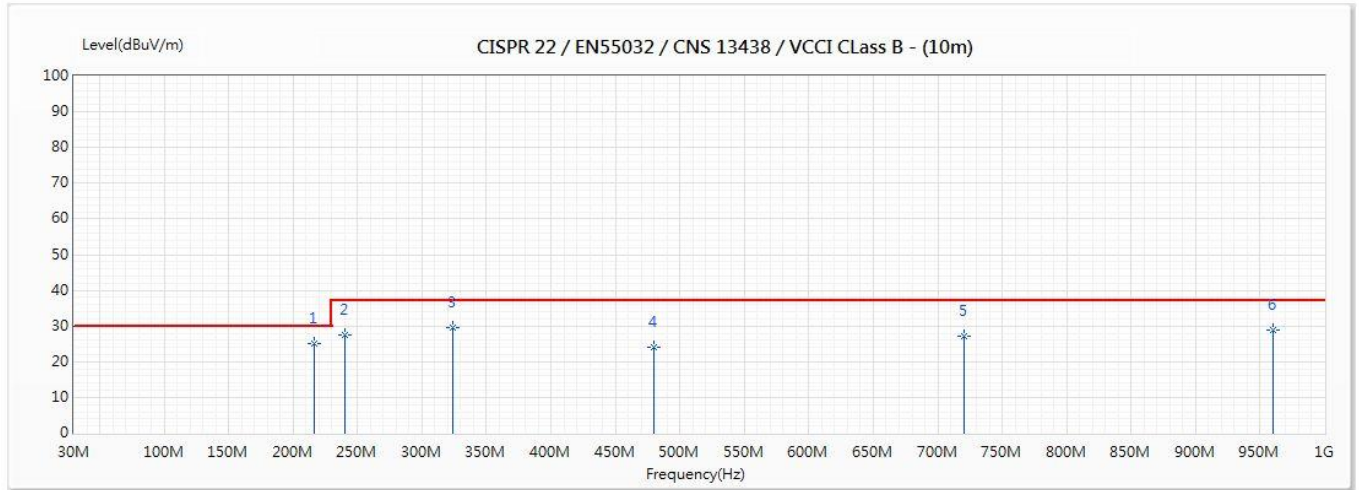

No	Frequency (MHz)	Emission Level (dBuV/m)	Limit (dBuV/m)	Margin (dB)	Reading Level (dBuV)	Correct Factor (dB/m)	Ant Pos (cm)	TT Pos (deg)	Detector Type
* 1	216	24.92	30.00	-5.08	37.30	-12.38	100	-73	QP
2	240	27.63	37.00	-9.37	38.30	-10.67	100	81	QP
3	323.73	29.42	37.00	-7.58	37.00	-7.58	100	-199	QP
4	480	23.96	37.00	-13.04	26.80	-2.84	100	-10	QP
5	720	27.01	37.00	-9.99	23.60	3.41	250	-81	QP
6	960	28.82	37.00	-8.18	20.30	8.52	150	8	QP

Remark:

1. "*" means this data is the worst emission level; "!" means this data is over limit.
2. Emission Level=Reading Level + Correct Factor(Correct Factor=Ant Factor+Cable Loss-Pre Amp).
3. Margin=Limit -Emission Level.

Site :	SITE4	Engineer :	Don
EUT	Bluetooth Speakerphone	Test Date :	2019/12/9
Test Voltage :	AC 120V/60Hz	Polarity :	Horizontal
Test Mode :	Mode 2		
Environmental Condition:	Temperature (°C) : 20.1 ; Relative Humidity (%RH) : 66		

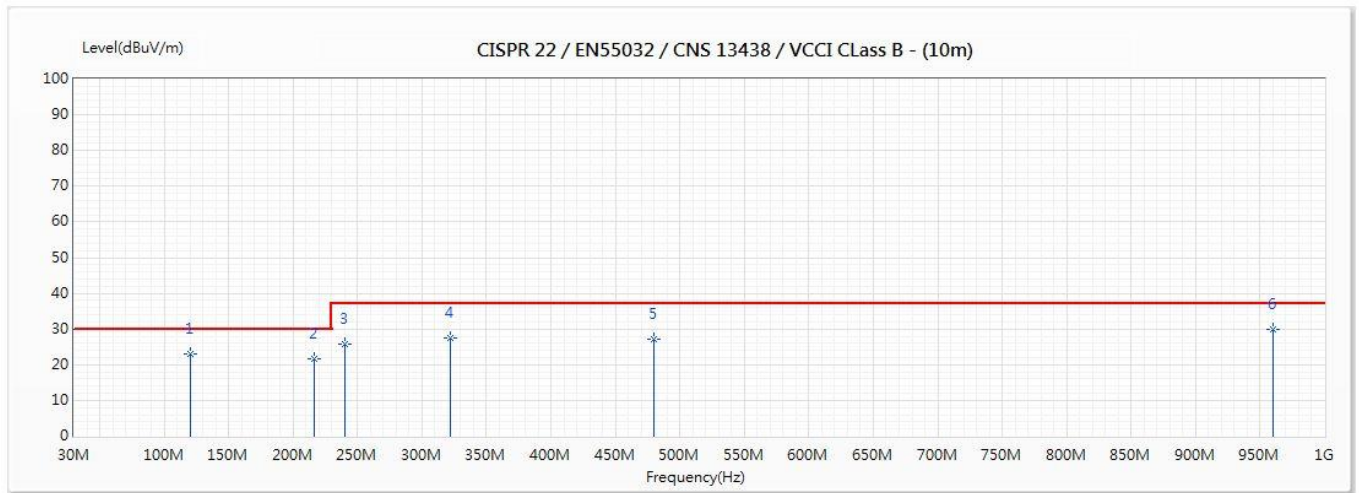

No	Frequency (MHz)	Emission Level (dBuV/m)	Limit (dBuV/m)	Margin (dB)	Reading Level (dBuV)	Correct Factor (dB/m)	Ant Pos (cm)	TT Pos (deg)	Detector Type
1	120	22.92	30.00	-7.08	35.80	-12.88	380	-81	QP
2	216	21.52	30.00	-8.48	33.90	-12.38	380	118	QP
3	240	25.63	37.00	-11.37	36.30	-10.67	380	144	QP
4	322	27.56	37.00	-9.44	35.20	-7.64	300	81	QP
5	480	27.26	37.00	-9.74	30.10	-2.84	200	-77	QP
* 6	960	30.02	37.00	-6.98	21.50	8.52	100	92	QP

Remark:

1. "*" means this data is the worst emission level; "!" means this data is over limit.
2. Emission Level=Reading Level + Correct Factor(Correct Factor=Ant Factor+Cable Loss-Pre Amp).
3. Margin=Limit -Emission Level.

Site :	SITE4	Engineer :	Don
EUT	Bluetooth Speakerphone	Test Date :	2019/12/9
Test Voltage :	AC 120V/60Hz	Polarity :	Vertical
Test Mode :	Mode 2		
Environmental Condition:	Temperature (°C) : 20.1 ; Relative Humidity (%RH) : 66		

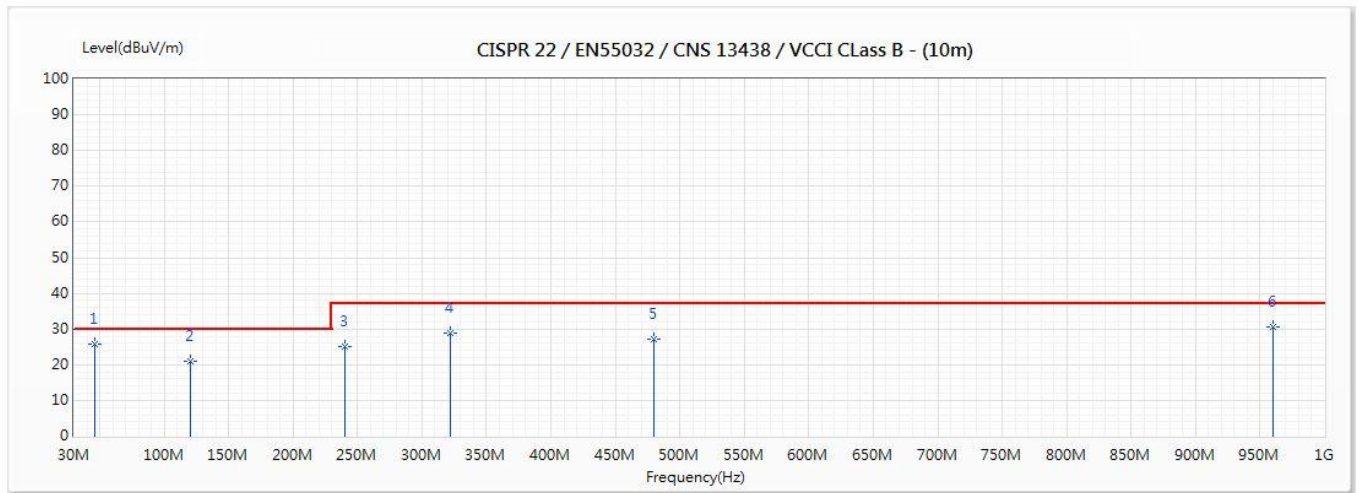

No	Frequency (MHz)	Emission Level (dBuV/m)	Limit (dBuV/m)	Margin (dB)	Reading Level (dBuV)	Correct Factor (dB/m)	Ant Pos (cm)	TT Pos (deg)	Detector Type
* 1	46.2	25.68	30.00	-4.32	35.81	-10.13	100	52	QP
2	120	21.02	30.00	-8.98	33.90	-12.88	100	-40	QP
3	240	25.03	37.00	-11.97	35.70	-10.67	100	81	QP
4	322.3	28.97	37.00	-8.03	36.60	-7.63	100	-93	QP
5	480	27.16	37.00	-9.84	30.00	-2.84	300	47	QP
6	960	30.72	37.00	-6.28	22.20	8.52	150	47	QP

Remark:

1. "*" means this data is the worst emission level; "!" means this data is over limit.
2. Emission Level=Reading Level + Correct Factor(Correct Factor=Ant Factor+Cable Loss-Pre Amp).
3. Margin=Limit -Emission Level.

Site: CB7	Time: 2019/12/06 - 23:38
Limit: FCC_B_(Above_1G)	Margin: 0
Probe: CB7_Horn_3117_1908	Polarity: Horizontal
EUT: Bluetooth Speakerphone	Power: AC 120V/60Hz
Note: 16.8°C ,77%RH, Mode 1	

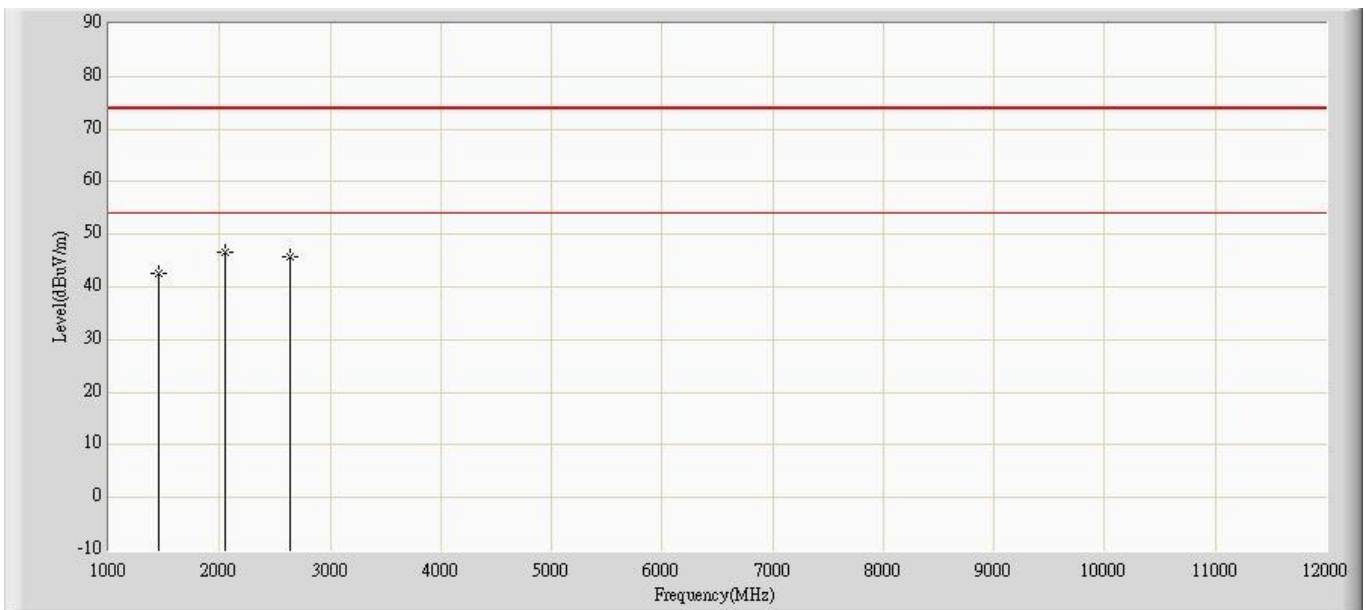

No	Flag	Mark	Frequency (MHz)	Measure Level (dBuV/m)	Reading Level (dBuV)	Over Limit (dB)	Limit (dBuV/m)	Factor	Ant Pos (cm)	Table Pos (deg)	Type
1			1450.000	42.634	56.050	-31.366	74.000	-13.416	100	150	PK
2		*	2051.000	46.499	55.600	-27.501	74.000	-9.102	100	10	PK
3			2637.000	45.884	53.050	-28.116	74.000	-7.166	100	-50	PK

Note:

1. All Readings below 1GHz are Quasi-Peak, above are performed with peak and/or average measurements as necessary.
2. " * ", means this data is the worst emission level.
3. Measurement Level = Reading Level + Correct Factor (LISN factor + cable loss).

Site: CB7	Time: 2019/12/06 - 23:39
Limit: FCC_B_(Above_1G)	Margin: 0
Probe: CB7_Horn_3117_1908	Polarity: Vertical
EUT: Bluetooth Speakerphone	Power: AC 120V/60Hz
Note: 16.8°C ,77%RH, Mode 1	

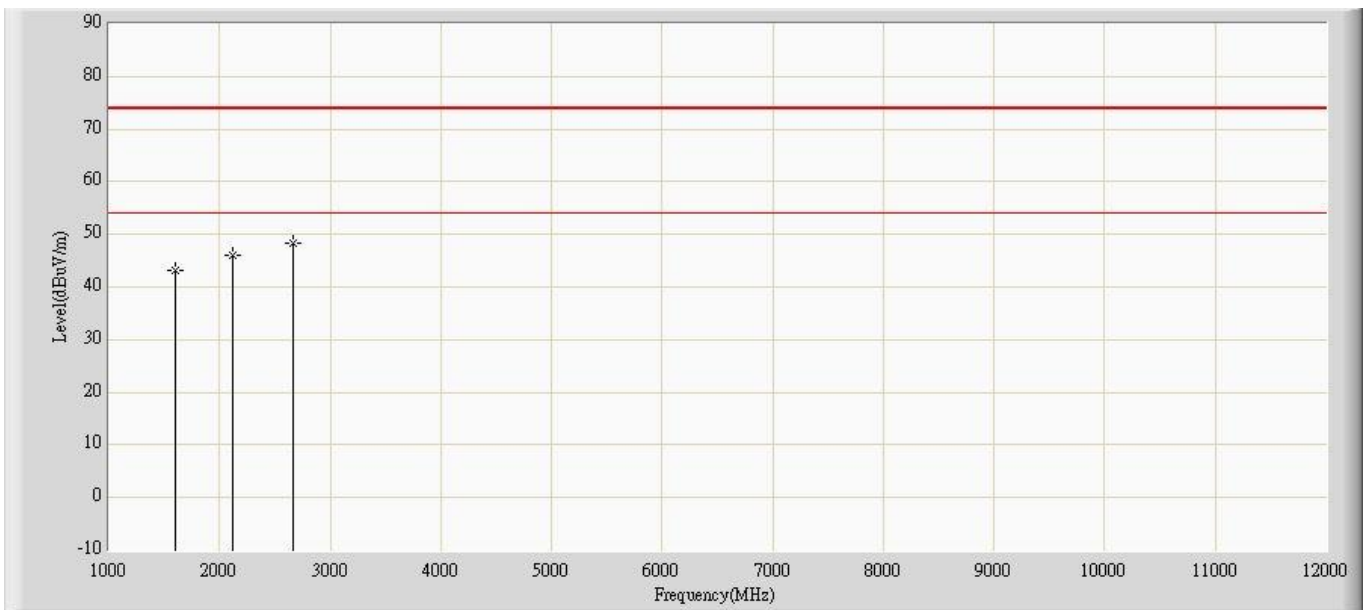

No	Flag	Mark	Frequency (MHz)	Measure Level (dBuV/m)	Reading Level (dBuV)	Over Limit (dB)	Limit (dBuV/m)	Factor	Ant Pos (cm)	Table Pos (deg)	Type
1			1595.000	43.081	55.970	-30.919	74.000	-12.889	100	100	PK
2			2125.000	46.162	54.890	-27.838	74.000	-8.728	100	60	PK
3		*	2660.000	48.355	55.390	-25.645	74.000	-7.035	100	30	PK

Note:

1. All Readings below 1GHz are Quasi-Peak, above are performed with peak and/or average measurements as necessary.
2. " * ", means this data is the worst emission level.
3. Measurement Level = Reading Level + Correct Factor (LISN factor + cable loss).

Site: CB7	Time: 2019/12/06 - 23:42
Limit: FCC_B_(Above_1G)	Margin: 0
Probe: CB7_Horn_3117_1908	Polarity: Horizontal
EUT: Bluetooth Speakerphone	Power: AC 120V/60Hz
Note: 16.8°C ,77%RH, Mode 2	

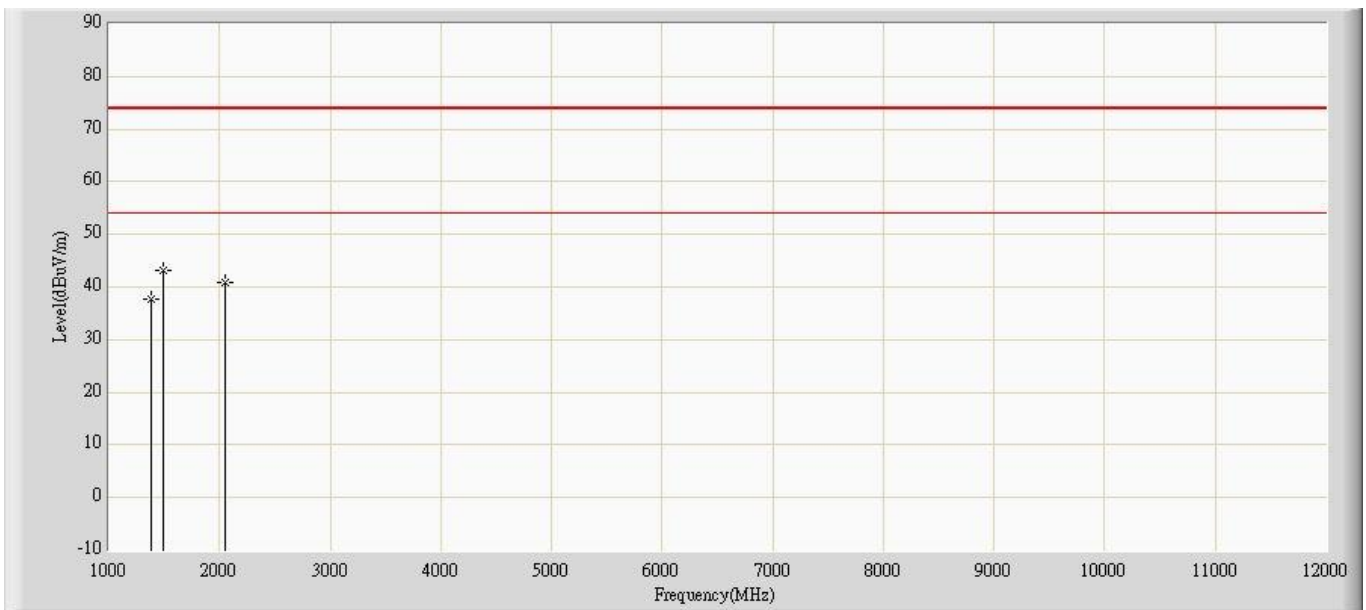

No	Flag	Mark	Frequency (MHz)	Measure Level (dBuV/m)	Reading Level (dBuV)	Over Limit (dB)	Limit (dBuV/m)	Factor	Ant Pos (cm)	Table Pos (deg)	Type
1			1379.000	37.594	50.890	-36.406	74.000	-13.296	100	80	PK
2		*	1497.000	43.120	56.780	-30.880	74.000	-13.660	100	10	PK
3			2045.000	40.768	49.890	-33.232	74.000	-9.122	100	100	PK

Note:

1. All Readings below 1GHz are Quasi-Peak, above are performed with peak and/or average measurements as necessary.
2. " * ", means this data is the worst emission level.
3. Measurement Level = Reading Level + Correct Factor (LISN factor + cable loss).

Site: CB7	Time: 2019/12/06 - 23:43
Limit: FCC_B_(Above_1G)	Margin: 0
Probe: CB7_Horn_3117_1908	Polarity: Vertical
EUT: Bluetooth Speakerphone	Power: AC 120V/60Hz
Note: 16.8°C ,77%RH, Mode 2	

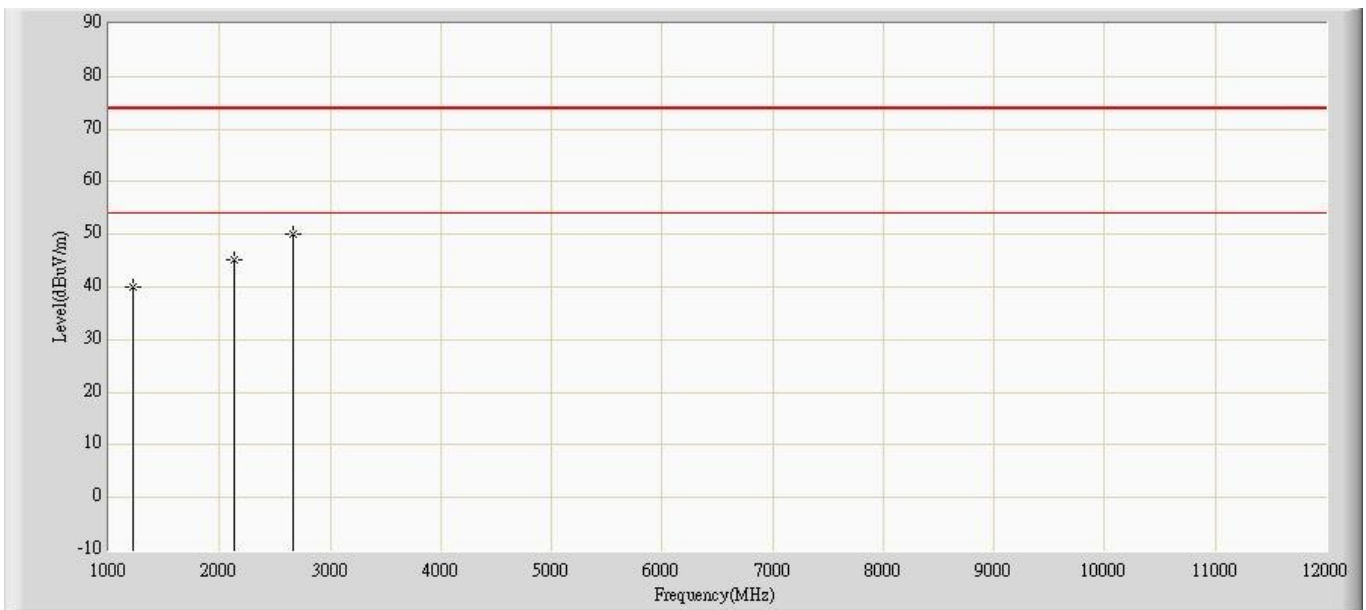

No	Flag	Mark	Frequency (MHz)	Measure Level (dBuV/m)	Reading Level (dBuV)	Over Limit (dB)	Limit (dBuV/m)	Factor	Ant Pos (cm)	Table Pos (deg)	Type
1			1219.000	40.122	53.560	-33.878	74.000	-13.438	100	50	PK
2			2134.000	45.171	53.900	-28.829	74.000	-8.728	100	70	PK
3		*	2670.000	49.925	56.890	-24.075	74.000	-6.965	100	100	PK

Note:

1. All Readings below 1GHz are Quasi-Peak, above are performed with peak and/or average measurements as necessary.
2. " * ", means this data is the worst emission level.
3. Measurement Level = Reading Level + Correct Factor (LISN factor + cable loss).

4.6. Test Photograph

Test Mode : Mode 1: BT + USB Dongle + Battery

Description : Front View of Radiated Test



Test Mode : Mode 1: BT + USB Dongle + Battery

Description : Back View of Radiated Test

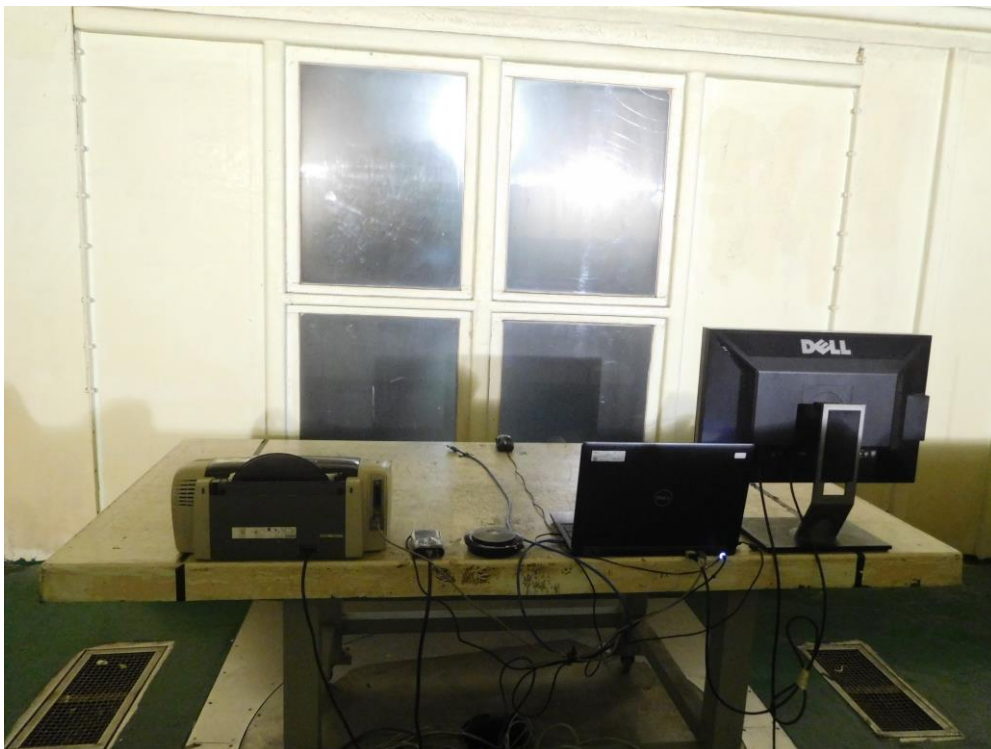

Test Mode : Mode 1: BT + USB Dongle + Battery

Description : Front View of High Frequency Radiated Test



Test Mode : Mode 2: USB + Charge

Description : Front View of Radiated Test



Test Mode : Mode 2: USB + Charge

Description : Back View of Radiated Test

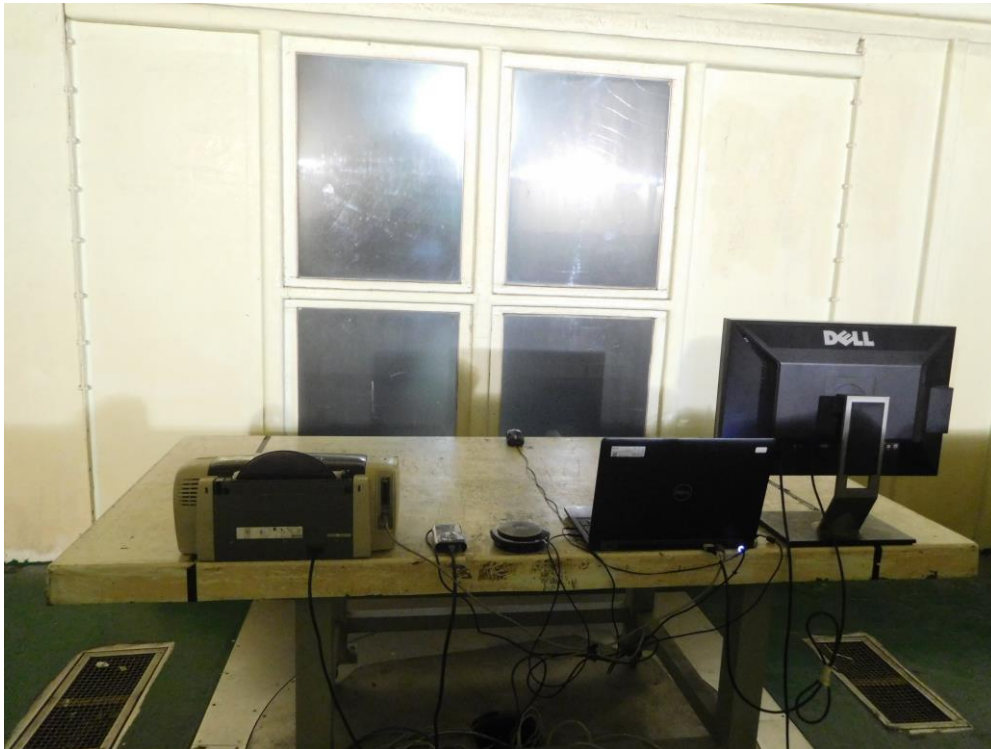

Test Mode : Mode 2: USB + Charge

Description : Front View of High Frequency Radiated Test



5. Attachment

➤ **EUT Photograph**

(1) EUT Photo



(2) EUT Photo



(3) EUT Photo_ USB Dongle



(4) EUT Photo

