

- NOTE:
1. COMMON TOLERANCE REFERS THE TOLERANCE TABLE.
  2. NO INDICATED FEATURE OR CURVE REFERS 3D FILES.
  3. CAVITY NO. SHOULD BE MADE ON THE INTERNAL SURFACE ON THE PART.
  4. PARTING LINE MISMATCH:0.05MM MAX.
  5. NO SHARP EDGE ARE ALLOWED.
  6. MATERIAL:SABIC CX 7240
  7. 0%MAXIMUM REGRIND MATERIAL PERMISSIBLE.
  8. SURFACE TREATMENT:N/A
  9. SURFACE FINISH:VDI-21.
  - 10.PRINTING: N/A
  - 11.COLOR:PANTONE BLACK
  - 12.TRANSMUTATION:
  - 13.MARK(Ⓜ):PROVIDE (CPK; CTF) VALUES.

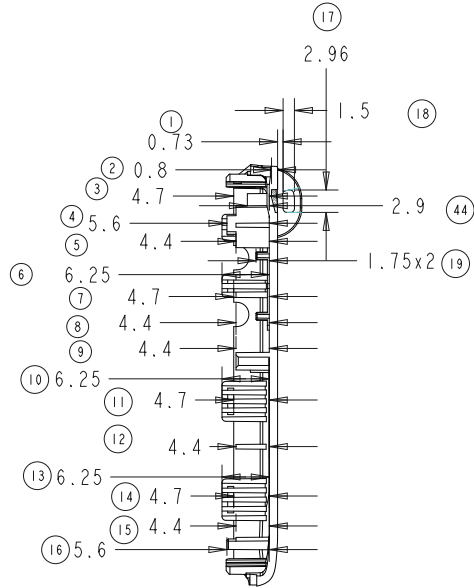

SECTION Y-Y

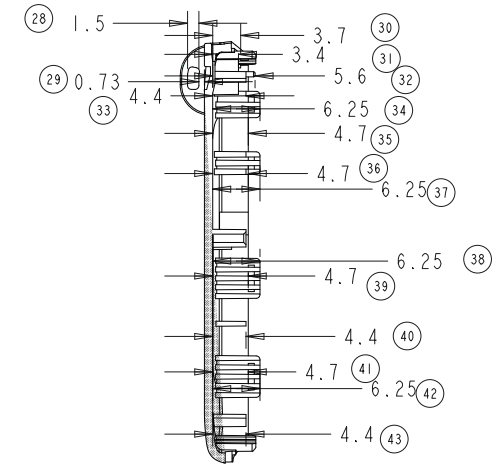
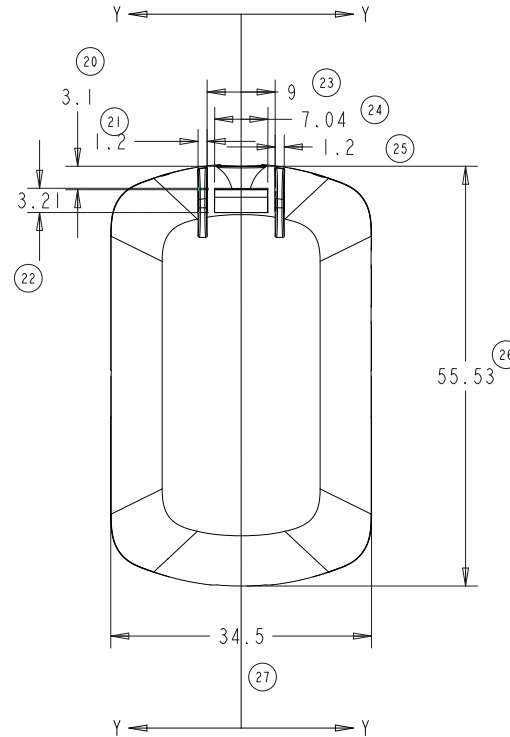

SECTION Y-Y

DIM	DEG	TOLERANCE				ANGLE	A 2	UNIT	SCALE	SHEET	MODEL No.	BSH-373		
		A	B	C	D							HOUSING		
0-5		±0.02	±0.05	±0.10		0°-30° ±0.1°	APPROVED	MM	FREE	1 of 2	PART NAME	4013000071D7	REV	I
5-10		±0.05	±0.10	±0.15		31°-60° ±0.3°	CHECKED			DESIGNED	PART No.			
10-50		±0.10	±0.15	±0.20		61°-90° ±0.5°								
50-100		±0.15	±0.20	±0.25										
100-		±0.15%	±0.20%	±0.25%										
ITEM	CONTENTS OF CHANGE	DRAWN	Y-M-D											

**LITEON** 光寶科技股份有限公司  
 LITE-ON TECHNOLOGY CORP.