

8
7
6
5
4
3
2
1

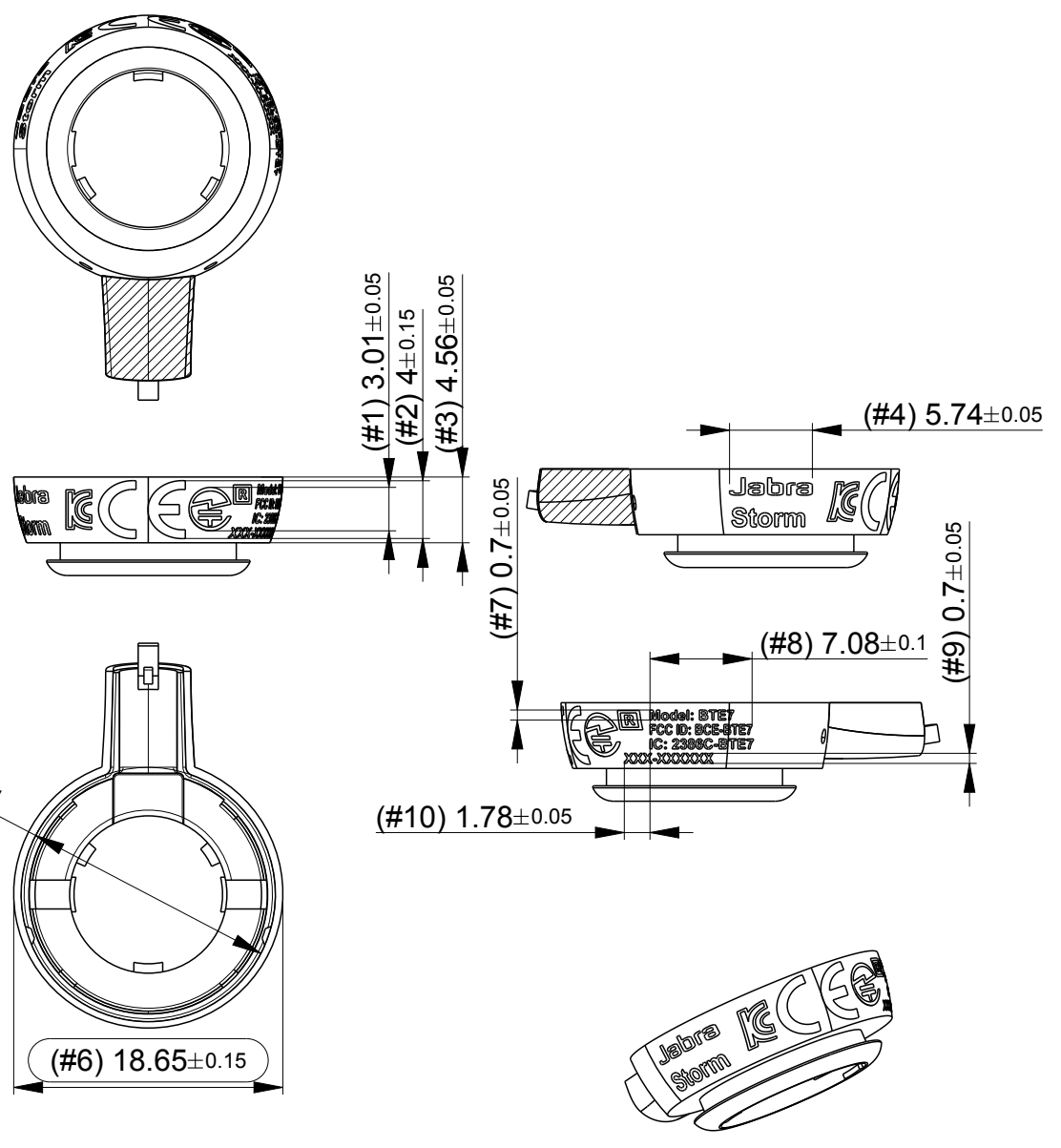

Note:
 1. All marked area should be covered by painting, other area should be masked;
 2. Painting spec and pad print refer to Agile information;
 3. Post treatment flow: raw material --> black base painting --> rubber painting --> pad print

Cosmetic Standard: GSC.ST.00002
 Part Marking.: GSC.PR.00102

CONFIDENTIALITY NOTICE:
 This document is the property of GN Netcom A/S and must be treated as confidential. The document must not be used, or disclosed to any third party, without written permission by GN Netcom A/S. Copyright © 2010 GN Netcom A/S. All rights reserved.

Process control dimensions are marked:
 IQC/OQC Characteristics for Evaluation:
 # 5

Date of Change: 26-Mar-2014	Description of Change: 3D drawing update, 2D version update	Responsible: Frank Lin
--------------------------------	--	---------------------------

	Matr. Spec: (See B.O.M.) Matr. type: PC 1414	3D revision: B	Created by: Frank Lin	Created on: 19-Feb-2014	Tool marking: . .	Drawing Scale: 2:1	Size: A4
	GN PDM file: 50-06940-WAVE2-EARBUD-RING ver:B.0	Object type: PART	Approved by: Mark Ye	Approved on: 20-Feb-2014	Units: mm	Projection: 	

Description: 50-07049-wave2-earbud-ring.drw	Document No: 50-07049	Doc. Revision: B	Design Status: Prereleased	Page No: 1 of 1
--	--------------------------	---------------------	-------------------------------	--------------------

A B C D E F