

FCC Measurement/Technical Report on Bluetooth Headset Jabra BTE6

FCC ID: BCE-BTE6A

Test Report Reference: MDE_GNNET_1601_FCCa_rev1

Test Laboratory:

7layers GmbH
Borsigstrasse 11
40880 Ratingen
Germany



Note:

The following test results relate only to the devices specified in this document. This report shall not be reproduced in parts without the written approval of the test laboratory.

7layers GmbH

Borsigstraße 11
40880 Ratingen, Germany
T +49 (0) 2102 749 0
F +49 (0) 2102 749 350

Geschäftsführer/
Managing Directors:
Frank Spiller
Bernhard Retka
Alexandre Norré-Oudard

Registergericht/registered:
Düsseldorf HRB 75554
USt-Id.-Nr./VAT-No. DE203159652
Steuer-Nr./TAX-No. 147/5869/0385

*a Bureau Veritas
Group Company*

www.7layers.com

Table of Contents

1	Applied Standards and Test Summary	3
1.1	Applied Standards	3
1.2	FCC-IC Correlation Table	4
1.3	Measurement Summary / Signatures	5
2	Administrative Data	10
2.1	Testing Laboratory	10
2.2	Project Data	10
2.3	Applicant Data	10
2.4	Manufacturer Data	10
3	Test object Data	11
3.1	General EUT Description	11
3.2	EUT Main components	11
3.3	Ancillary Equipment	12
3.4	Auxiliary Equipment	12
3.5	EUT Setups	12
3.6	Operating Modes	13
3.7	Product labelling	13
4	Test Results	14
4.1	Conducted Emissions at AC Mains	14
4.2	Occupied Bandwidth (20 dB)	17
4.3	Peak Power Output	22
4.4	Spurious RF Conducted Emissions	26
4.5	Transmitter Spurious Radiated Emissions	30
4.6	Band Edge Compliance Conducted	34
4.7	Band Edge Compliance Radiated	38
4.8	Channel Separation	43
4.9	Dwell Time	45
4.10	Number of Hopping Frequencies	47
5	Test Equipment	49
6	Setup Drawings	52
7	Measurement Uncertainties	53
8	Photo Report	53

1 Applied Standards and Test Summary

1.1 Applied Standards

Type of Authorization

Certification for an Intentional Radiator.

Applicable FCC Rules

Prepared in accordance with the requirements of FCC Rules and Regulations as listed in 47 CFR Ch.1 Parts 2 and 15 (10-1-13 Edition). The following subparts are applicable to the results in this test report.

Part 2, Subpart J - Equipment Authorization Procedures, Certification

Part 15, Subpart C – Intentional Radiators

§ 15.201 Equipment authorization requirement

§ 15.207 Conducted limits

§ 15.209 Radiated emission limits; general requirements

§ 15.247 Operation within the bands 902-928 MHz, 2400-2483.5 MHz

Note 1:

The tests were selected and performed with reference to the FCC Public Notice DA 00-705, released March 30, 2000. Instead of applying ANSI C63.4-1992 which is referenced in the FCC Public Note, the newer ANSI C63.10-2013 is applied.

Summary Test Results:

The EUT complied with all performed tests as listed in chapter 1.3 Measurement Summary / Signatures.

1.2 FCC-IC Correlation Table

**Correlation of measurement requirements for
FHSS (e.g. Bluetooth®) equipment
from
FCC and IC**

FHSS equipment

Measurement	FCC reference	IC reference
Conducted emissions on AC Mains	§ 15.207	RSS-Gen Issue 4: 8.8
Occupied bandwidth	§ 15.247 (a) (1)	RSS-247 Issue 1: 5.1 (2)
Peak conducted output power	§ 15.247 (b) (1), (4)	RSS-247 Issue 1: 5.4 (2)
Transmitter spurious RF conducted emissions	§ 15.247 (d)	RSS-Gen Issue 4: 6.13/8.9/8.10; RSS-247 Issue 1: 5.5
Transmitter spurious radiated emissions	§ 15.247 (d); § 15.209 (a)	RSS-Gen Issue 4: 6.13 / 8.9/8.10; RSS-247 Issue 1: 5.5
Band edge compliance	§ 15.247 (d)	RSS-247 Issue 1: 5.5
Dwell time	§ 15.247 (a) (1) (iii)	RSS-247 Issue 1: 5.1 (4)
Channel separation	§ 15.247 (a) (1)	RSS-247 Issue 1: 5.1 (2)
No. of hopping frequencies	§ 15.247 (a) (1) (iii)	RSS-247 Issue 1: 5.1 (4)
Hybrid systems (only)	§ 15.247 (f); § 15.247 (e)	RSS-247 Issue 1: 5.3
Antenna requirement	§ 15.203 / 15.204	RSS-Gen Issue 4: 8.3
Receiver spurious emissions	-	-

1.3 Measurement Summary / Signatures

47 CFR CHAPTER I FCC PART 15 Subpart C § 15.207 §15.247

Conducted Emissions at AC Mains

The measurement was performed according to ANSI C63.10

Final Result

OP-Mode	Setup	FCC	IC
Operating mode			
worst case	Setup_AB02	Passed	Passed

47 CFR CHAPTER I FCC PART 15 Subpart C § 15.247 (a) (1) §15.247

Occupied Bandwidth (20 dB)

The measurement was performed according to ANSI C63.10

Final Result

OP-Mode	Setup	FCC	IC
Radio Technology, Operating Frequency			
Bluetooth BDR, high	Setup_AA01	Passed	Passed
Bluetooth BDR, low	Setup_AA01	Passed	Passed
Bluetooth BDR, mid	Setup_AA01	Passed	Passed
Bluetooth EDR 2, high	Setup_AA01	Passed	Passed
Bluetooth EDR 2, low	Setup_AA01	Passed	Passed
Bluetooth EDR 2, mid	Setup_AA01	Passed	Passed
Bluetooth EDR 3, high	Setup_AA01	Passed	Passed
Bluetooth EDR 3, low	Setup_AA01	Passed	Passed
Bluetooth EDR 3, mid	Setup_AA01	Passed	Passed

47 CFR CHAPTER I FCC PART 15 Subpart C § 15.247 (b) (1) §15.247

Peak Power Output

The measurement was performed according to ANSI C63.10

Final Result

OP-Mode	Setup	FCC	IC
Radio Technology, Operating Frequency, Measurement method			
Bluetooth BDR, high, conducted	Setup_AA01	Passed	Passed
Bluetooth BDR, low, conducted	Setup_AA01	Passed	Passed
Bluetooth BDR, mid, conducted	Setup_AA01	Passed	Passed

OP-Mode Radio Technology, Operating Frequency, Measurement method	Setup	FCC	IC
Bluetooth EDR 2, high, conducted	Setup_AA01	Passed	Passed
Bluetooth EDR 2, low, conducted	Setup_AA01	Passed	Passed
Bluetooth EDR 2, mid, conducted	Setup_AA01	Passed	Passed
Bluetooth EDR 3, high, conducted	Setup_AA01	Passed	Passed
Bluetooth EDR 3, low, conducted	Setup_AA01	Passed	Passed
Bluetooth EDR 3, mid, conducted	Setup_AA01	Passed	Passed

47 CFR CHAPTER I FCC PART 15 Subpart C
§15.247

§ 15.247 (d)

Spurious RF Conducted Emissions The measurement was performed according to ANSI C63.10		Final Result	
OP-Mode Radio Technology, Operating Frequency	Setup	FCC	IC
Bluetooth BDR, high	Setup_AA01	Passed	Passed
Bluetooth BDR, low	Setup_AA01	Passed	Passed
Bluetooth BDR, mid	Setup_AA01	Passed	Passed
Bluetooth EDR 2, high	Setup_AA01	Passed	Passed
Bluetooth EDR 2, low	Setup_AA01	Passed	Passed
Bluetooth EDR 2, mid	Setup_AA01	Passed	Passed
Bluetooth EDR 3, high	Setup_AA01	Passed	Passed
Bluetooth EDR 3, low	Setup_AA01	Passed	Passed
Bluetooth EDR 3, mid	Setup_AA01	Passed	Passed

47 CFR CHAPTER I FCC PART 15 Subpart C
§15.247

§ 15.247 (d)

Transmitter Spurious Radiated Emissions The measurement was performed according to ANSI C63.10		Final Result	
OP-Mode Radio Technology, Operating Frequency, Measurement range	Setup	FCC	IC
Bluetooth BDR, high, 1 GHz - 26 GHz	Setup_AB01	Passed	Passed
Bluetooth BDR, high, 30 MHz - 1 GHz	Setup_AB01	Passed	Passed
Bluetooth BDR, low, 1 GHz - 26 GHz	Setup_AB01	Passed	Passed

OP-Mode Radio Technology, Operating Frequency, Measurement range	Setup	FCC	IC
Bluetooth BDR, low, 30 MHz - 1 GHz	Setup_AB01	Passed	Passed
Bluetooth BDR, mid, 1 GHz - 26 GHz	Setup_AB01	Passed	Passed
Bluetooth BDR, mid, 30 MHz - 1 GHz	Setup_AB02	Passed	Passed
Bluetooth BDR, mid, 9 kHz - 30 MHz	Setup_AB01	Passed	Passed
Bluetooth EDR 2, high, 1 GHz - 26 GHz Remark: Tested in the range 1-8 GHz only	Setup_AB01	Passed	Passed
Bluetooth EDR 2, low, 1 GHz - 26 GHz Remark: Tested in the range 1-8 GHz only	Setup_AB01	Passed	Passed
Bluetooth EDR 2, mid, 1 GHz - 26 GHz Remark: Tested in the range 1-8 GHz only	Setup_AB01	Passed	Passed
Bluetooth EDR 3, high, 1 GHz - 26 GHz Remark: Tested in the range 1-8 GHz only	Setup_AB01	Passed	Passed
Bluetooth EDR 3, low, 1 GHz - 26 GHz Remark: Tested in the range 1-8 GHz only	Setup_AB01	Passed	Passed
Bluetooth EDR 3, mid, 1 GHz - 26 GHz Remark: Tested in the range 1-8 GHz only	Setup_AB01	Passed	Passed

47 CFR CHAPTER I FCC PART 15 Subpart C
§15.247

§ 15.247 (d)

Band Edge Compliance Conducted		Final Result	
The measurement was performed according to ANSI C63.10			
OP-Mode Radio Technology, Operating Frequency, Band Edge	Setup	FCC	IC
Bluetooth BDR, high, high	Setup_AA01	Passed	Passed
Bluetooth BDR, hopping, high	Setup_AA01	Passed	Passed
Bluetooth BDR, hopping, low	Setup_AA01	Passed	Passed
Bluetooth BDR, low, low	Setup_AA01	Passed	Passed
Bluetooth EDR 2, high, high	Setup_AA01	Passed	Passed
Bluetooth EDR 2, hopping, high	Setup_AA01	Passed	Passed
Bluetooth EDR 2, hopping, low	Setup_AA01	Passed	Passed
Bluetooth EDR 2, low, low	Setup_AA01	Passed	Passed
Bluetooth EDR 3, high, high	Setup_AA01	Passed	Passed
Bluetooth EDR 3, hopping, high	Setup_AA01	Passed	Passed
Bluetooth EDR 3, hopping, low	Setup_AA01	Passed	Passed

OP-Mode	Setup	FCC	IC
Radio Technology, Operating Frequency, Band Edge Bluetooth EDR 3, low, low	Setup_AA01	Passed	Passed

47 CFR CHAPTER I FCC PART 15 Subpart C § 15.247 (d)
§15.247

Band Edge Compliance Radiated
The measurement was performed according to ANSI C63.10

Final Result

OP-Mode	Setup	FCC	IC
Radio Technology, Operating Frequency, Band Edge Bluetooth BDR, high, high	Setup_AB01	Passed	Passed
Bluetooth EDR 2, high, high	Setup_AB01	Passed	Passed
Bluetooth EDR 3, high, high	Setup_AB01	Passed	Passed

47 CFR CHAPTER I FCC PART 15 Subpart C § 15.247 (a) (1)
§15.247

Channel Separation
The measurement was performed according to ANSI C63.10

Final Result

OP-Mode	Setup	FCC	IC
Radio Technology Bluetooth BDR	Setup_AA01	Passed	Passed

47 CFR CHAPTER I FCC PART 15 Subpart C § 15.247 (a) (1) (iii)
§15.247

Dwell Time
The measurement was performed according to ANSI C63.10

Final Result

OP-Mode	Setup	FCC	IC
Radio Technology Bluetooth BDR	Setup_AA01	Passed	Passed

47 CFR CHAPTER I FCC PART 15 Subpart C § 15.247 (a) (1) (iii)
§15.247

Number of Hopping Frequencies
The measurement was performed according to ANSI C63.10

Final Result

OP-Mode	Setup	FCC	IC
Radio Technology Bluetooth BDR	Setup_AA01	Passed	Passed

N/A: Not applicable
N/P: Not performed

(responsible for accreditation scope)
Dipl.-Ing. Marco Kullik

(responsible for testing and report)
Dipl.-Ing. Daniel Gall

Revision History

Report version control			
Version	Release date	Change Description	Version validity
initial	2016-04-13	--	invalid
rev1	2016-04-27	Deleted two DTS references, corrected analyzer settings description testcase Peak Power Output, corrected calibration data.	valid

2 Administrative Data

2.1 Testing Laboratory

Company Name: 7layers GmbH
Address: Borsigstr. 11
40880 Ratingen
Germany

This facility has been fully described in a report submitted to the FCC and accepted under the registration number 96716.

This facility has been fully described in a report submitted to the IC and accepted under the registration number: Site# 3699A-1.

The test facility is also accredited by the following accreditation organisation:

Laboratory accreditation no: DAkkS D-PL-12140-01-01
Responsible for accreditation scope: Dipl.-Ing. Marco Kullik
Report Template Version: 2016-02-29

2.2 Project Data

Responsible for testing and report: Dipl.-Ing. Daniel Gall
Employees who performed the tests: documented internally at 7Layers
Date of Report: 2016-04-27
Testing Period: 2016-03-30 to 2016-03-31

2.3 Applicant Data

Company Name: GN Netcom A/S
Address: Lautrupbjerg 7
DK-2750 Ballerup
Denmark
Contact Person: Mr. Tom Ringtved

2.4 Manufacturer Data

Company Name: Please see at applicant data
Address:

Contact Person:

3 Test object Data

3.1 General EUT Description

Kind of Device product description	Bluetooth Transceiver operating in the 2.4 GHz ISM band using frequency hopping spread spectrum (FHSS) modulation
Product name	Bluetooth Headset
Type	Jabra BTE6
Declared EUT data by the supplier	
Voltage Type	DC
Voltage Level	5 V
Tested Modulation Type	GFSK (BDR), n/4 DQPSK (EDR 2), 8-DPSK (EDR 3)
General product description	The EUT is an Bluetooth headset
Specific product description for the EUT	The EUT has a build in Bluetooth Transceiver operating in the 2.4 GHz ISM band using frequency hopping spread spectrum (FHSS) modulation on 79 channels.
The EUT provides the following ports:	Enclosure, USB, USB cable Linoya AWM 2725 E315619 1m
Tested datarates	1 Mbps (BDR) / 2 Mbps (EDR 2) / 3Mbps (EDR 3)

The main components of the EUT are listed and described in chapter 3.2 EUT Main components.

3.2 EUT Main components

Sample Name	Sample Code	Description
DE1021015aa01	aa01	conducted sample
Sample Parameter	Value	
Integral Antenna	Replaced by temporary antenna connector	
Serial No.	TA-1	
HW Version	28-04732	
SW Version	1.0.3	
Comment		

Sample Name	Sample Code	Description
DE1021015ab01	ab01	radiated sample
Sample Parameter	Value	
Integral Antenna	2.5 dBi	
Serial No.	TA-2	
HW Version	28-04732	
SW Version	1.0.3	
Comment		

NOTE: The short description is used to simplify the identification of the EUT in this test report.

3.3 Ancillary Equipment

For the purposes of this test report, ancillary equipment is defined as equipment which is used in conjunction with the EUT to provide operational and control features to the EUT. It is necessary to configure the system in a typical fashion, as a customer would normally use it. But nevertheless Ancillary Equipment can influence the test results.

Device	Details (Manufacturer, Type Model, OUT Code)	Description
-	-	-

3.4 Auxiliary Equipment

For the purposes of this test report, auxiliary equipment is defined as equipment which is used temporarily to enable operational and control features especially used for the tests of the EUT which is not used during normal operation or equipment that is used during the tests in combination with the EUT but is not subject of this test report. It is necessary to configure the system in a typical fashion, as a customer would normally use it. But nevertheless Auxiliary Equipment can influence the test results.

Device	Details (Manufacturer, HW, SW, S/N)	Description
TC E250	HTC, -, -, 2RSA119F022294	USB AC/DC adapter

3.5 EUT Setups

This chapter describes the combination of EUTs and equipment used for testing. The rationale for selecting the EUTs, ancillary and auxiliary equipment and interconnecting cables, is to test a representative configuration meeting the requirements of the referenced standards.

Setup	Combination of EUTs	Description and Rationale
Setup_AA01	DE1021015aa01	
Setup_AB01	DE1021015ab01	
Setup_AB02	DE1021015ab01, TC E250	

3.6 Operating Modes

This chapter describes the operating modes of the EUTs used for testing.

3.6.1 Test Channels

BT Test Channels:
Channel:
Frequency [MHz]

2.4 GHz ISM 2400 - 2483.5 MHz		
low	mid	high
0	39	78
2402	2441	2480

3.7 Product labelling

3.7.1 FCC ID label

Please refer to the documentation of the applicant.

3.7.2 Location of the label on the EUT

Please refer to the documentation of the applicant.

4 Test Results

4.1 Conducted Emissions at AC Mains

Standard **47 CFR CHAPTER I FCC PART 15 Subpart C §15.247**

The test was performed according to: ANSI C63.10

4.1.1 Test Description

The test set-up was made in accordance to the general provisions of ANSI C 63.10. The Equipment Under Test (EUT) was setup in a shielded room to perform the conducted emissions measurements in a typical installation configuration. The EUT was powered from 50 μ H || 50 Ohm Line Impedance Stabilization Network (LISN). The LISN's unused connections were terminated with 50 Ohm loads.

The measurement procedure consists of two steps. It is implemented into the EMI test software EMC-32 from R&S.

Step 1: Preliminary scan

Intention of this step is, to determine the conducted EMI-profile of the EUT.

EMI receiver settings:

- Detector: Peak – Maxhold & Average
- Frequency range: 150 kHz – 30 MHz
- Frequency steps: 2.5 kHz
- IF-Bandwidth: 9 kHz
- Measuring time / Frequency step: 100 ms (FFT-based)
- Measurement on phase + neutral lines of the power cords

On basis of this preliminary scan the highest amplitudes and the corresponding frequencies relative to the limit are identified. Emissions above the limit and emissions which are in the 10 dB range below the limit are considered.

Step 2: Final measurement

Intention of this step is, to determine the highest emissions with the settings defined in the test specification for the frequencies identified in step 1.

EMI receiver settings:

- Detector: Quasi-Peak
- IF Bandwidth: 9 kHz
- Measuring time: 1 s / frequency

At each frequency determined in step 1, four measurements are performed in the following combinations:

- 1) Neutral lead - reference ground (PE grounded)
- 2) Phase lead - reference ground (PE grounded)
- 3) Neutral lead - reference ground (PE floating)
- 4) Phase lead - reference ground (PE floating)

The highest value is reported.

4.1.2 Test Requirements / Limits

FCC Part 15, Subpart C, §15.207

Frequency Range (MHz)	QP Limit (dB μ V)	AV Limit (dB μ V)
0.15 – 0.5	66 to 56	56 to 46
0.5 – 5	56	46
5 – 30	60	50

Used conversion factor: Limit (dB μ V) = 20 log (Limit (μ V)/1 μ V).

4.1.3 Test Protocol

Temperature: 23 °C
 Air Pressure: 1001 hPa
 Humidity: 34 %
 AC/DC adapter

Power line	Frequency [kHz]	Level [dB μ V]	Detector	Limit [dB μ V]	Margin [dB]
N	264.8	21.2	AV	51.3	30.1
N	269.3	41.0	QP	61.1	20.2
N	705.8	21.8	AV	46.0	24.2
N	964.5	29.7	QP	56.0	26.3
N	1365.0	23.8	QP	56.0	32.2
N	1497.8	25.5	QP	56.0	30.5
N	1626.0	22.7	QP	56.0	33.3
N	1628.3	15.8	AV	46.0	30.2
L1	1754.3	25.0	QP	56.0	31.0
N	1889.3	18.8	AV	46.0	27.2
L1	2982.8	24.4	QP	56.0	31.6
L1	3115.5	25.6	QP	56.0	30.4
N	3124.5	16.0	AV	46.0	30.0
N	3252.8	17.4	AV	46.0	28.6
L1	3255.0	25.0	QP	56.0	31.0
N	3385.5	17.6	AV	46.0	28.4
L1	9768.8	24.2	QP	60.0	35.8

Remark: Please see next sub-clause for the measurement plot.

4.1.4 Measurement Plot (showing the highest value, “worst case”)

Operating mode = worst case

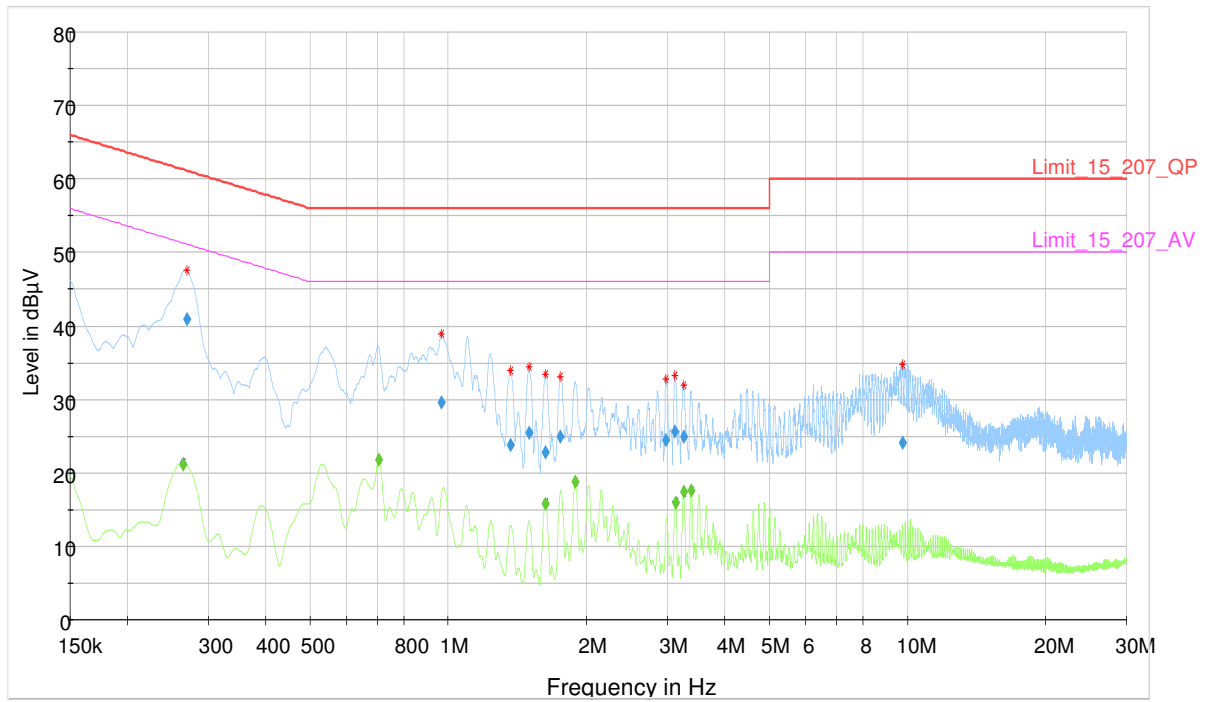

4.1.5 Test Equipment used

Conducted Emissions

4.2 Occupied Bandwidth (20 dB)

Standard **47 CFR CHAPTER I FCC PART 15 Subpart C §15.247**

The test was performed according to: ANSI C63.10

4.2.1 Test Description

The Equipment Under Test (EUT) was set up to perform the occupied bandwidth measurements.

The reference level is the level of the highest amplitude signal observed from the transmitter at either the fundamental frequency or first-order modulation products in all typical modes of operation, including the unmodulated carrier, even if atypical.

The results recorded were measured with the modulation which produce the worst-case (widest) emission bandwidth.

The EUT was connected to spectrum analyzer via a short coax cable with a known loss.

Analyzer settings:

- Resolution Bandwidth (RBW): 1% to 5 % of the OBW
- Video Bandwidth (VBW): 3 x RBW
- Span: 2 to 5 times the OBW
- Trace: Maxhold
- Sweeps: 2000
- Sweep time: 20 ms
- Detector: Peak

The technology depending measurement parameters can be found in the measurement plot.

4.2.2 Test Requirements / Limits

FCC Part 15, Subpart C, §15.247 (a) (2)

For the band: 902 – 928 MHz

FCC Part 15, Subpart C, §15.247 (a) (1) (i)

The maximum allowed 20 dB bandwidth of the hopping channel is 500 kHz

For the band: 5725 – 5850 MHz

FCC Part 15, Subpart C, §15.247 (a) (1) (ii)

The maximum allowed 20 dB bandwidth of the hopping channel is 1 MHz

For the frequency band 2400 – 2483.5 MHz:

FCC Part 15, Subpart C, §15.247 (a) (1) (iii)

Frequency hopping systems shall have hopping channel carrier frequencies separated by a minimum of 25 kHz or the 20 dB bandwidth of the hopping channel, whichever is greater. Alternatively, frequency hopping systems operating in the 2400–2483.5 MHz band may

have hopping channel carrier frequencies that are separated by 25 kHz or two-thirds of the 20 dB bandwidth of the hopping channel, whichever is greater, provided the systems operate with an output power no greater than 125 mW. The system shall hop to channel frequencies that are selected at the system hopping rate from a pseudo randomly ordered list of hopping frequencies. Each frequency must be used equally on the average by each transmitter. The system receivers shall have input bandwidths that match the hopping channel bandwidths of their corresponding transmitters and shall shift frequencies in synchronization with the transmitted signals.

Implication by the test laboratory:

Since the Bluetooth technology defines a fixed channel separation of 1 MHz this design parameter defines the maximum allowed occupied bandwidth depending on the EUT's output power:

1. Under the provision that the system operates with an output power not greater than 125 mW (21.0 dBm):

Implicit Limit: Max. 20 dB BW = $1.0 \text{ MHz} / 2/3 = 1.5 \text{ MHz}$

2. If the system output power exceeds 125 mW (21.0 dBm):

Implicit Limit: Max. 20 dB BW = 1.0 MHz

Used conversion factor: Output power (dBm) = $10 \log (\text{Output power (W)} / 1\text{mW})$

The measured output power of the system is below 125 mW (21.0 dBm). For the results, please refer to the related chapter of this report.

Therefore the limit is determined as 1.5 MHz.

4.2.3 Test Protocol

Ambient temperature: 23 °C
 Air Pressure: 1019 hPa
 Humidity: 41 %
 BT GFSK (1-DH1)

Band	Channel No.	Frequency [MHz]	20 dB Bandwidth [kHz]	Limit [kHz]	Margin to Limit [kHz]
2.4 GHz ISM	0	2402.0	980.4	1500.0	519.6
	39	2441.0	1016.4	1500.0	483.6
	78	2480.0	1028.4	1500.0	471.6

BT π/4 DQPSK (2-DH1)

Band	Channel No.	Frequency [MHz]	20 dB Bandwidth [kHz]	Limit [kHz]	Margin to Limit [kHz]
2.4 GHz ISM	0	2402.0	1293.6	1500.0	206.4
	39	2441.0	1299.6	1500.0	200.4
	78	2480.0	1287.6	1500.0	212.4

BT 8-DPSK (3-DH1)

Band	Channel No.	Frequency [MHz]	20 dB Bandwidth [kHz]	Limit [kHz]	Margin to Limit [kHz]
2.4 GHz ISM	0	2402.0	1287.6	1500.0	212.4
	39	2441.0	1287.6	1500.0	212.4
	78	2480.0	1281.6	1500.0	218.4

Remark: Please see next sub-clause for the measurement plot.

4.2.4 Measurement Plot (showing the highest value, "worst case")

Radio Technology = Bluetooth EDR 3, Operating Frequency = mid

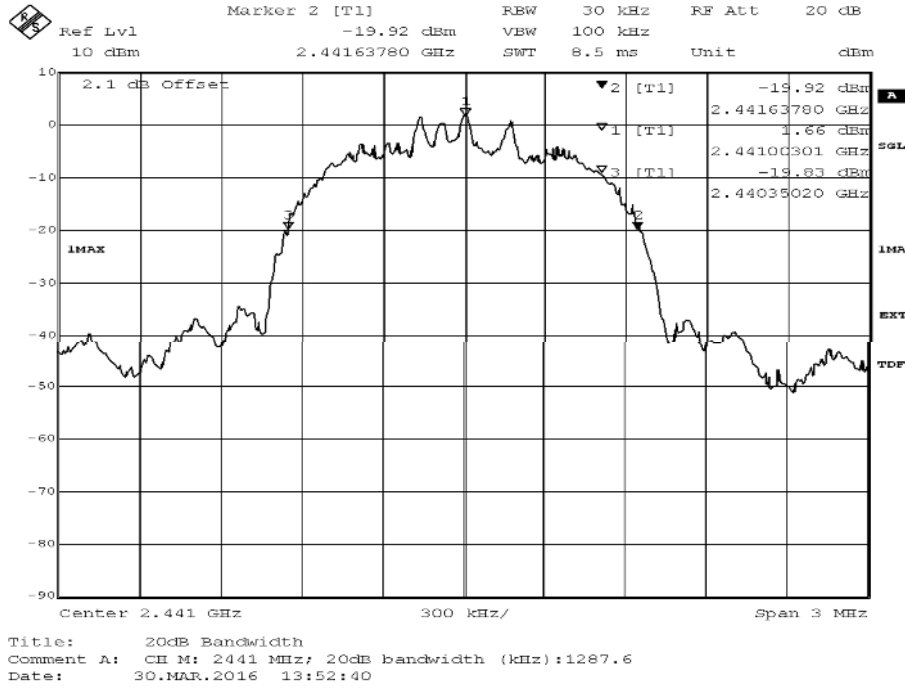

Radio Technology = Bluetooth BDR, Operating Frequency = high

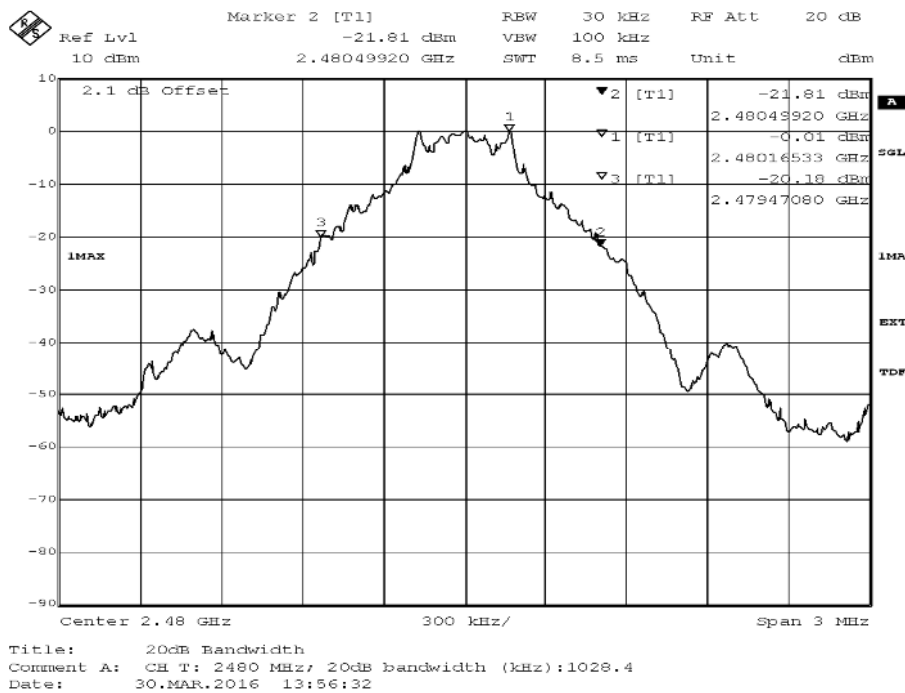

Radio Technology = Bluetooth EDR 2, Operating Frequency = mid

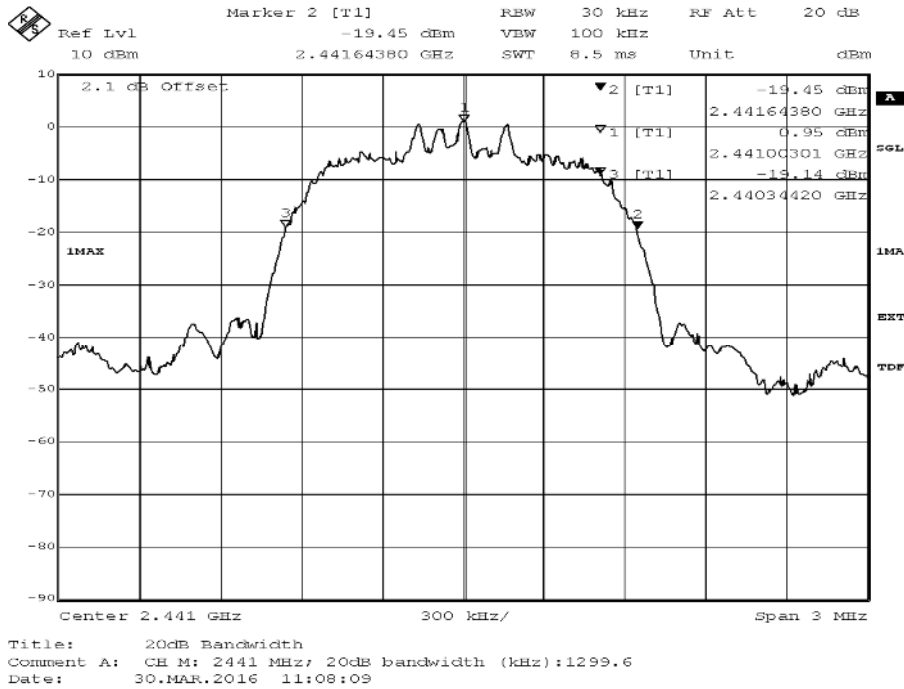

4.2.5 Test Equipment used

Regulatory Bluetooth RF Test Solution

4.3 Peak Power Output

Standard **47 CFR CHAPTER I FCC PART 15 Subpart C §15.247**

The test was performed according to: ANSI C63.10

4.3.1 Test Description

The Equipment Under Test (EUT) was set up to perform the output power measurements. The results recorded were measured with the modulation which produces the worst-case (highest) output power. The reference level of the spectrum analyzer was set higher than the output power of the EUT.

The EUT was connected to the spectrum analyzer via a short coax cable with a known loss.

Analyzer settings:

- Resolution Bandwidth (RBW): 3 MHz
- Video Bandwidth (VBW): 3 MHz
- Trace: Maxhold
- Sweeps: 2000
- Sweep time: 5 ms
- Detector: Peak

4.3.2 Test Requirements / Limits

DTS devices:

FCC Part 15, Subpart C, §15.247 (b) (3)

For systems using digital modulation techniques in the 902-928 MHz, 2400-2483.5 MHz and 5725-5850 MHz bands: 1 watt.

=> Maximum conducted peak output power: 30 dBm (excluding antenna gain, if antennas with directional gains that do not exceed 6 dBi are used).

Frequency Hopping Systems:

FCC Part 15, Subpart C, §15.247 (b) (1)

For frequency hopping systems operating in the 2400-2483.5 MHz band employing at least 75 non-overlapping hopping channels, and all frequency hopping systems in the 5725-5850 MHz band: 1 watt. For all other frequency hopping systems in the 2400-2483.5 MHz band: 0.125 watts.

FCC Part 15, Subpart C, §15.247 (b) (2)

For frequency hopping systems operating in the 902-928 MHz band: 1 watt for systems employing at least 50 hopping channels; and, 0.25 watts for systems employing less than 50 hopping channels, but at least 25 hopping channels, as permitted under paragraph (a)(1)(i) of this section.

Used conversion factor: Limit (dBm) = 10 log (Limit (W)/1mW)

4.3.3 Test Protocol

Ambient temperature: 23 °C
 Air Pressure: 1019 hPa
 Humidity: 41 %
 BT GFSK (1-DH1)

Band	Channel No.	Frequency [MHz]	Peak Power [dBm]	Limit [dBm]	Margin to Limit [dB]
2.4 GHz ISM	0	2402.0	0.0	30.0	30.0
	39	2441.0	0.9	30.0	29.1
	78	2480.0	1.4	30.0	28.6

BT π/4 DQPSK (2-DH1)

Band	Channel No.	Frequency [MHz]	Peak Power [dBm]	Limit [dBm]	Margin to Limit [dB]
2.4 GHz ISM	0	2402.0	2.9	30.0	27.1
	39	2441.0	3.7	30.0	26.3
	78	2480.0	4.3	30.0	25.8

BT 8-DPSK (3-DH1)

Band	Channel No.	Frequency [MHz]	Peak Power [dBm]	Limit [dBm]	Margin to Limit [dB]
2.4 GHz ISM	0	2402.0	3.4	30.0	26.6
	39	2441.0	4.6	30.0	25.4
	78	2480.0	4.7	30.0	25.3

Remark: Please see next sub-clause for the measurement plot.

4.3.4 Measurement Plot (showing the highest value, "worst case")

Radio Technology = Bluetooth EDR 2, Operating Frequency = high, Measurement method = conducted

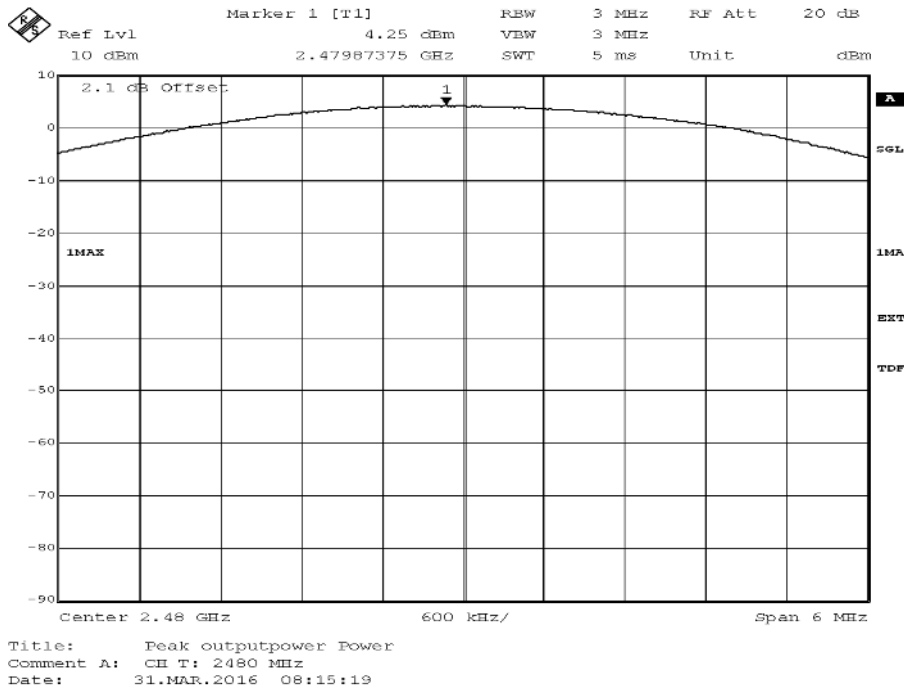

Radio Technology = Bluetooth EDR 3, Operating Frequency = high, Measurement method = conducted

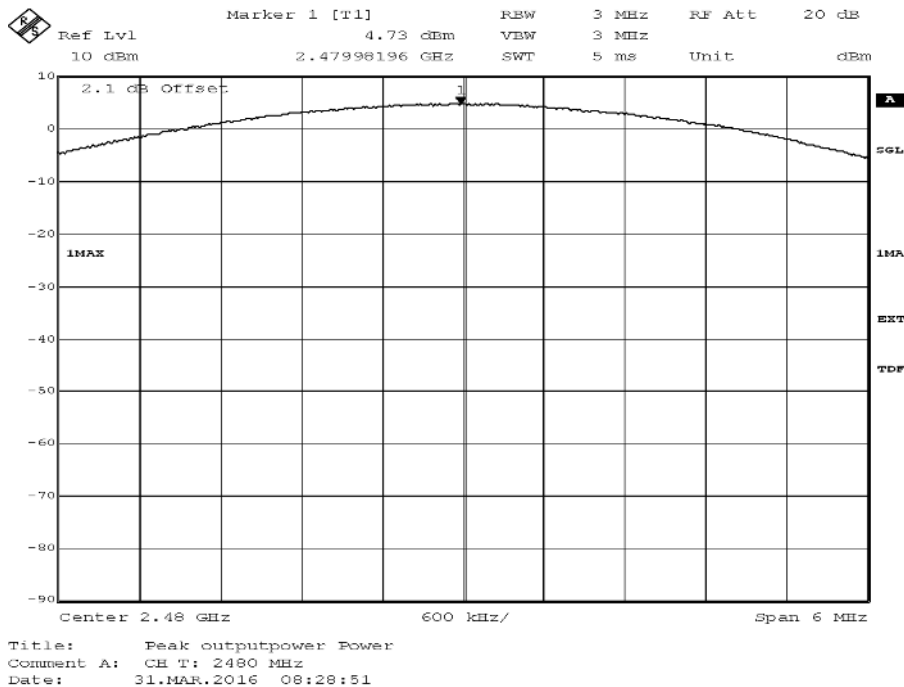

Radio Technology = Bluetooth BDR, Operating Frequency = high, Measurement method = conducted

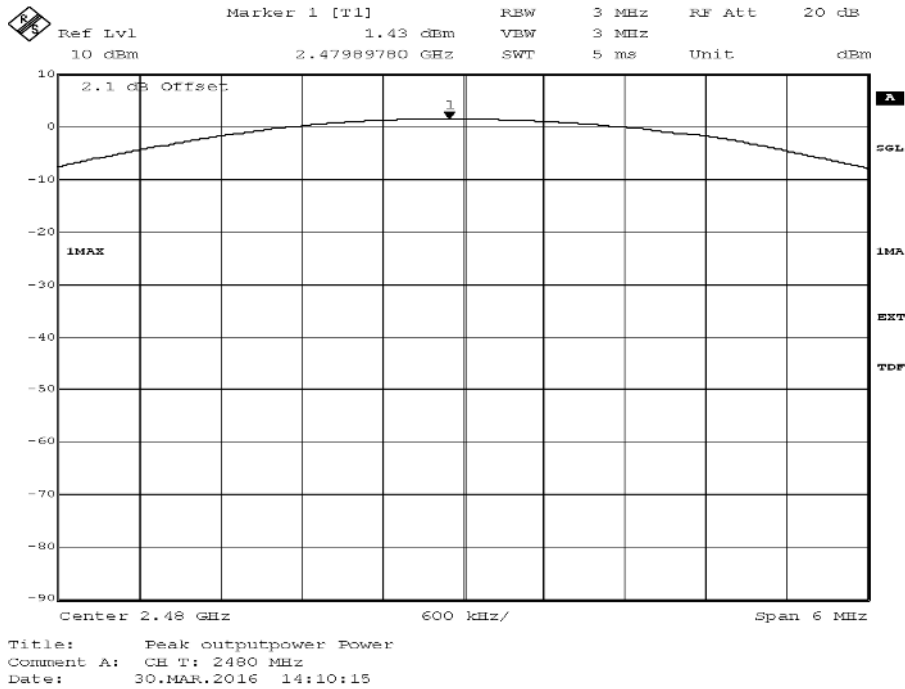

4.3.5 Test Equipment used

Regulatory Bluetooth RF Test Solution

4.4 Spurious RF Conducted Emissions

Standard **47 CFR CHAPTER I FCC PART 15 Subpart C §15.247**

The test was performed according to: ANSI C63.10

4.4.1 Test Description

The Equipment Under Test (EUT) was set up to perform the spurious emissions measurements.

The EUT was connected to spectrum analyzer via a short coax cable with a known loss.

Analyzer settings:

- Frequency range: 30 – 25000 MHz
- Resolution Bandwidth (RBW): 100 kHz
- Video Bandwidth (VBW): 300 kHz
- Trace: Maxhold
- Sweeps: 2
- Sweep Time: 330 s
- Detector: Peak

The reference value for the measurement of the spurious RF conducted emissions is determined during the test “band edge compliance conducted”. This value is used to calculate the 20 dBc limit.

4.4.2 Test Requirements / Limits

FCC Part 15, Subpart C, §15.247 (c)

In any 100 kHz bandwidth outside the frequency band in which the spread spectrum intentional radiator is operating, the radio frequency power that is produced by the intentional radiator shall be at least 20 dB below that in the 100 kHz bandwidth within the band that contains the highest level of the desired power, based on either an RF conducted or a radiated measurement, provided the transmitter demonstrates compliance with the peak conducted power limits. If the transmitter complies with the conducted power limits based on the use of RMS averaging over a time interval, as permitted under paragraph (b)(3) of this section, the attenuation required under this paragraph shall be 30 dB instead of 20 dB.

4.4.3 Test Protocol

Ambient temperature: 23 °C
 Air Pressure: 1019 hPa
 Humidity: 41 %
 BT GFSK (1-DH1)

Channel No	Channel Center Freq. [MHz]	Spurious Freq. [MHz]	Spurious Level [dBm]	Detector	RBW [kHz]	Ref. Level [dBm]	Limit [dBm]	Margin to Limit [dB]
0	2402.0	-	-	PEAK	100.0	-0.5	-20.5	-
39	2441.0	-	-	PEAK	100.0	0.5	-19.5	-
78	2480.0	-	-	PEAK	100.0	1.0	-19.0	-

BT π/4 DQPSK (2-DH1)

Channel No	Channel Center Freq. [MHz]	Spurious Freq. [MHz]	Spurious Level [dBm]	Detector	RBW [kHz]	Ref. Level [dBm]	Limit [dBm]	Margin to Limit [dB]
0	2402.0	-	-	PEAK	100.0	1.1	-18.9	-
39	2441.0	-	-	PEAK	100.0	1.8	-18.2	-
78	2480.0	-	-	PEAK	100.0	2.4	-17.6	-

BT 8-DPSK (3-DH1)

Channel No	Channel Center Freq. [MHz]	Spurious Freq. [MHz]	Spurious Level [dBm]	Detector	RBW [kHz]	Ref. Level [dBm]	Limit [dBm]	Margin to Limit [dB]
0	2402.0	-	-	PEAK	100.0	1.1	-18.9	-
39	2441.0	-	-	PEAK	100.0	2.3	-17.7	-
78	2480.0	-	-	PEAK	100.0	2.5	-17.5	-

Remark: Please see next sub-clause for the measurement plot.

4.4.4 Measurement Plot (showing the highest value, "worst case")

Radio Technology = Bluetooth EDR 2, Operating Frequency = high

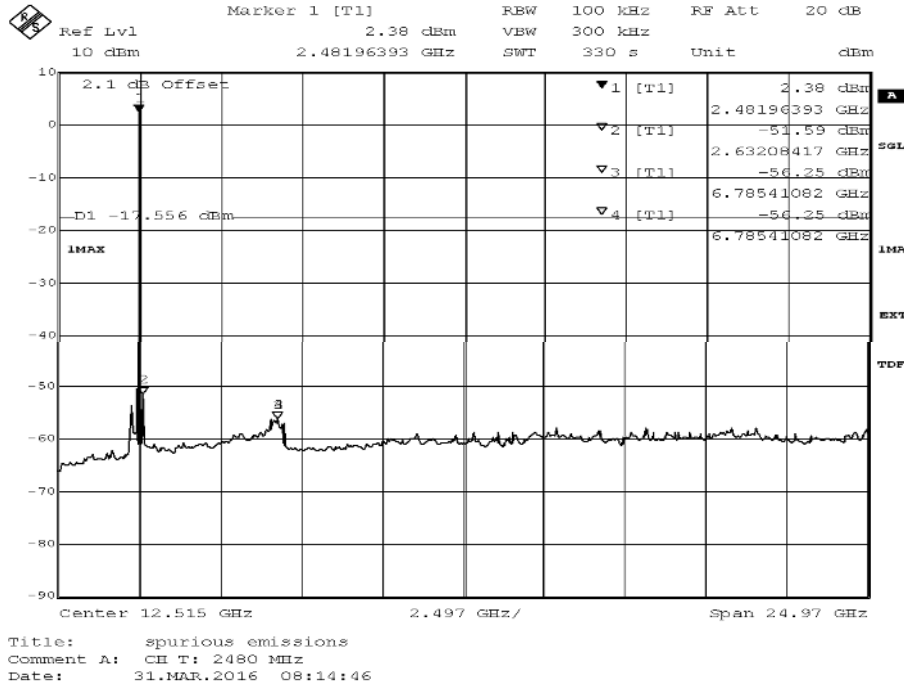

Radio Technology = Bluetooth BDR, Operating Frequency = high

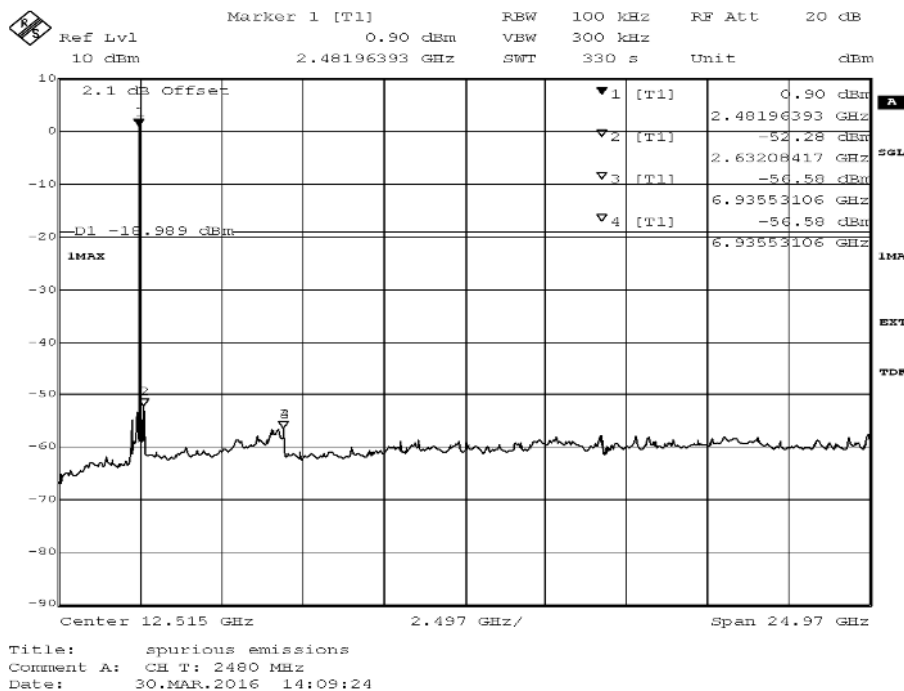

Radio Technology = Bluetooth EDR 3, Operating Frequency = high

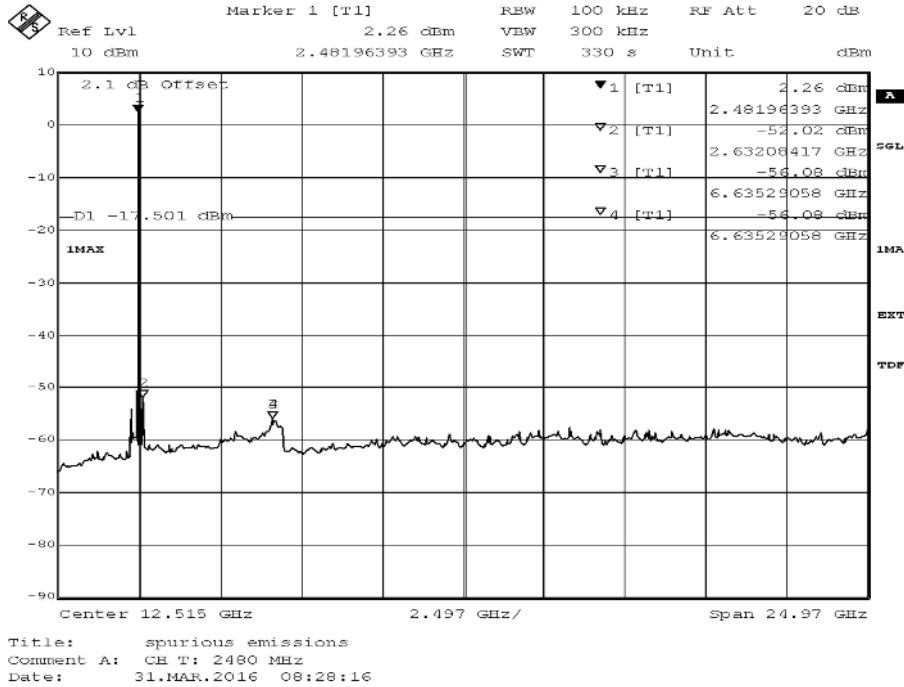

4.4.5 Test Equipment used

Regulatory Bluetooth RF Test Solution

4.5 Transmitter Spurious Radiated Emissions

Standard **47 CFR CHAPTER I FCC PART 15 Subpart C §15.247**

The test was performed according to: ANSI C63.10

4.5.1 Test Description

The test set-up was made in accordance to the general provisions of ANSI C63.10 in a typical installation configuration. The Equipment Under Test (EUT) was set up on a non-conductive table 1.0 x 2.0 m² in the semi-anechoic chamber. The influence of the EUT support table that is used between 30–1000 MHz was evaluated.

The measurement procedure is implemented into the EMI test software EMC32 from R&S. Exploratory tests are performed at 3 orthogonal axes to determine the worst-case orientation of a body-worn or handheld EUT. The final test on all kind of EUTs is also performed at 3 axes. A pre-check is performed while the EUT is powered from a DC power source.

1. Measurement up to 30 MHz

The Loop antenna HFH2-Z2 is used.

Step 1: pre measurement

- Anechoic chamber
- Antenna distance: 3 m
- Detector: Peak-Maxhold
- Frequency range: 0.009 - 0.15 MHz and 0.15 – 30 MHz
- Frequency steps: 0.05 kHz and 2.25 kHz
- IF-Bandwidth: 0.2 kHz and 9 kHz
- Measuring time / Frequency step: 100 ms (FFT-based)

Intention of this step is, to determine the radiated EMI-profile of the EUT. Afterwards the relevant emissions for the final measurement are identified.

Step 2: final measurement

For the relevant emissions determined in step 1, an additional measurement with the following settings will be performed. Intention of this step is to find the maximum emission level.

- Open area test side
- Antenna distance: according to the Standard
- Detector: Quasi-Peak
- Frequency range: 0.009 – 30 MHz
- Frequency steps: measurement at frequencies detected in step 1
- IF-Bandwidth: 0.2 - 10 kHz
- Measuring time / Frequency step: 1 s

2. Measurement above 30 MHz and up to 1 GHz

Step 1: Preliminary scan

This is a preliminary test to identify the highest amplitudes relative to the limit.

Settings for step 1:

- Antenna distance: 3 m
- Detector: Peak-Maxhold / Quasipeak (FFT-based)
- Frequency range: 30 – 1000 MHz
- Frequency steps: 30 kHz

- IF-Bandwidth: 120 kHz
- Measuring time / Frequency step: 100 ms
- Turntable angle range: -180° to 90°
- Turntable step size: 90°
- Height variation range: 1 – 3 m
- Height variation step size: 2 m
- Polarisation: Horizontal + Vertical

Intention of this step is, to determine the radiated EMI-profile of the EUT. Afterwards the relevant emissions for the final measurement are identified.

Step 2: Adjustment measurement

In this step the accuracy of the turntable azimuth and antenna height will be improved. This is necessary to find out the maximum value of every frequency.

For each frequency, which was determined the turntable azimuth and antenna height will be adjusted. The turntable azimuth will slowly vary by $\pm 45^{\circ}$ around this value. During this action, the value of emission is continuously measured. The turntable azimuth at the highest emission will be recorded and adjusted. In this position, the antenna height will also slowly vary by ± 100 cm around the antenna height determined. During this action, the value of emission is also continuously measured. The antenna height of the highest emission will also be recorded and adjusted.

- Detector: Peak – Maxhold
- Measured frequencies: in step 1 determined frequencies
- IF – Bandwidth: 120 kHz
- Measuring time: 100 ms
- Turntable angle range: $\pm 45^{\circ}$ around the determined value
- Height variation range: ± 100 cm around the determined value
- Antenna Polarisation: max. value determined in step 1

Step 3: Final measurement with QP detector

With the settings determined in step 3, the final measurement will be performed:

EMI receiver settings for step 4:

- Detector: Quasi-Peak (< 1 GHz)
- Measured frequencies: in step 1 determined frequencies
- IF – Bandwidth: 120 kHz
- Measuring time: 1 s

After the measurement a plot will be generated which contains a diagram with the results of the preliminary scan and a chart with the frequencies and values of the results of the final measurement.

3. Measurement above 1 GHz

The following modifications apply to the measurement procedure for the frequency range above 1 GHz:

Step 1:

The Equipment Under Test (EUT) was set up on a non-conductive support (tilt device) at 1.5 m height in the fully-anechoic chamber.

All steps were performed with one height (1.5 m) of the receiving antenna only.

The EUT is turned during the preliminary measurement across the elevation axis, with a step size of 90° .

The turn table step size (azimuth angle) for the preliminary measurement is 45° .

Step 2:

Due to the fact, that in this frequency range the test is performed in a fully anechoic room, the height scan of the receiving antenna instep 2 is omitted. Instead of this, a maximum search with a step size $\pm 45^{\circ}$ for the elevation axis is performed.

The turn table azimuth will slowly vary by $\pm 22.5^{\circ}$.

The elevation angle will slowly vary by $\pm 45^\circ$

EMI receiver settings (for all steps):

- Detector: Peak, Average
- IF Bandwidth = 1 MHz

Step 3:

Spectrum analyser settings for step 3:

- Detector: Peak / Average
- Measured frequencies: in step 1 determined frequencies
- IF – Bandwidth: 1 MHz
- Measuring time: 1 s

4.5.2 Test Requirements / Limits

FCC Part 15, Subpart C, §15.247 (d)

... In addition, radiated emissions which fall in the restricted bands, as defined in Section 15.205(a), must also comply with the radiated emission limits specified in Section 15.209(a) (see Section 15.205(c)).

FCC Part 15, Subpart C, §15.209, Radiated Emission Limits

Frequency in MHz	Limit ($\mu\text{V}/\text{m}$)	Measurement distance (m)	Limits ($\text{dB}\mu\text{V}/\text{m}$)
0.009 – 0.49	2400/F(kHz)@300m	3	(48.5 – 13.8)@300m
0.49 – 1.705	24000/F(kHz)@30m	3	(33.8 – 23.0)@30m
1.705 – 30	30@30m	3	29.5@30m

The measured values are corrected with an inverse linear distance extrapolation factor (40 dB/decade) according FCC 15.31 (2).

Frequency in MHz	Limit ($\mu\text{V}/\text{m}$)	Measurement distance (m)	Limits ($\text{dB}\mu\text{V}/\text{m}$)
30 – 88	100@3m	3	40.0@3m
88 – 216	150@3m	3	43.5@3m
216 – 960	200@3m	3	46.0@3m
960 - 26000	500@3m	3	54.0@3m
26000 - 40000	500@3m	1	54.0@3m

The measured values above 26 GHz are corrected with an inverse linear distance extrapolation factor (20 dB/decade).

§15.35(b) ..., there is also a limit on the radio frequency emissions, as measured using instrumentation with a peak detector function, corresponding to 20 dB above the maximum permitted average limit....

Used conversion factor: $\text{Limit (dB}\mu\text{V}/\text{m)} = 20 \log (\text{Limit } (\mu\text{V}/\text{m})/1\mu\text{V}/\text{m)}$

4.5.3 Test Protocol

Ambient temperature: 22–23 °C

Air Pressure: 1001–1002 hPa

Humidity: 34–38 %

BT GFSK (1-DH1)

Ch. No.	Ch. Center Freq. [MHz]	Spurious Freq. [MHz]	Spurious Level [dBµV/m]	Detector	RBW [kHz]	Limit [dBµV/m]	Margin to Limit [dB]	Limit Type
0	2402.0	---	---	---	---	---	---	RB
39	2441.0	---	---	---	---	---	---	RB
78	2480.0	---	---	---	---	---	---	RB

BT π/4 DQPSK (2-DH1)

Ch. No.	Ch. Center Freq. [MHz]	Spurious Freq. [MHz]	Spurious Level [dBµV/m]	Detector	RBW [kHz]	Limit [dBµV/m]	Margin to Limit [dB]	Limit Type
0	2402.0	---	---	---	---	---	---	RB
39	2441.0	---	---	---	---	---	---	RB
78	2480.0	---	---	---	---	---	---	RB

BT 8-DPSK (3-DH1)

Ch. No.	Ch. Center Freq. [MHz]	Spurious Freq. [MHz]	Spurious Level [dBµV/m]	Detector	RBW [kHz]	Limit [dBµV/m]	Margin to Limit [dB]	Limit Type
0	2402.0	---	---	---	---	---	---	RB
39	2441.0	---	---	---	---	---	---	RB
78	2480.0	---	---	---	---	---	---	RB

Remark: . No (further) peaks in the range 20 dB below the peak limit found.

4.5.4 Test Equipment used

Radiated Emissions

4.6 Band Edge Compliance Conducted

Standard **47 CFR CHAPTER I FCC PART 15 Subpart C §15.247**

The test was performed according to: ANSI C63.10

4.6.1 Test Description

For the conducted measurement, the Equipment Under Test (EUT) is placed in a shielded room. The reference power was measured in the test case "Spurious RF Conducted Emissions".

The EUT was connected to the spectrum analyzer via a short coax cable with a known loss.

Analyzer settings:

- Frequency Range 30 MHz – 25 GHz
- Detector: Peak
- Resolution Bandwidth (RBW): 100 kHz
- Video Bandwidth (VBW): 300 kHz
- Sweep time: 330 s
- Sweeps: 2
- Trace: Maxhold

4.6.2 Test Requirements / Limits

FCC Part 15.247 (d)

"In any 100 kHz bandwidth outside the frequency band in which the spread spectrum or digitally modulated intentional radiator is operating, the radio frequency power that is produced by the intentional radiator shall be at least 20 dB below that in the 100 kHz bandwidth within the band that contains the highest level of the desired power, based on either an RF conducted or a radiated measurement, provided the transmitter demonstrates compliance with the peak conducted power limits. ...

If the transmitter complies with the conducted power limits based on the use of RMS averaging over a time interval, as permitted under paragraph (b)(3) of this section, the attenuation required under this paragraph shall be 30 dB instead of 20 dB. Attenuation below the general limits specified in Section 15.209(a) is not required. In addition, radiated emissions which fall in the restricted bands, as defined in Section 15.205(a), must also comply with the radiated emission limits specified in Section 15.209(a) (see Section 15.205(c))."

For the conducted measurement the RF power at the band edge shall be "at least 20 dB below that in the 100 kHz bandwidth within the band that contains the highest level of the desired power..."

4.6.3 Test Protocol

Ambient temperature: 23 °C
 Air Pressure: 1019 hPa
 Humidity: 41 %
 BT GFSK (1-DH1)

Channel No.	Channel Center Freq. [MHz]	Band Edge Freq. [MHz]	Spurious Level [dBm]	Detector	RBW [kHz]	Ref. Level [dBm]	Limit [dBμV/m]	Margin to Limit [dB]
0	2402.0	2400.0	-50.2	PEAK	100.0	-0.5	-20.5	29.7
78	2480.0	2483.5	-62.4	PEAK	100.0	1.0	-19.0	43.4
hopping	hopping	2400.0	-51.2	PEAK	100.0	-0.4	-20.4	30.8
hopping	hopping	2483.5	-54.2	PEAK	100.0	-0.5	-20.5	33.8

BT π/4 DQPSK (2-DH1)

Channel No.	Channel Center Freq. [MHz]	Band Edge Freq. [MHz]	Spurious Level [dBm]	Detector	RBW [kHz]	Ref. Level [dBm]	Limit [dBm]	Margin to Limit [dB]
0	2402.0	2400.0	-41.7	PEAK	100.0	1.1	-18.9	22.8
78	2480.0	2483.5	-61.6	PEAK	100.0	2.4	-17.6	44.1
hopping	hopping	2400.0	-42.7	PEAK	100.0	1.0	-19.0	23.7
hopping	hopping	2483.5	-53.7	PEAK	100.0	1.0	-19.0	34.8

BT 8-DPSK (3-DH1)

Channel No.	Channel Center Freq. [MHz]	Band Edge Freq. [MHz]	Spurious Level [dBm]	Detector	RBW [kHz]	Ref. Level [dBm]	Limit [dBm]	Margin to Limit [dB]
0	2402.0	2400.0	-41.5	PEAK	100.0	1.1	-18.9	22.6
78	2480.0	2483.5	-60.7	PEAK	100.0	2.5	-17.5	43.2
hopping	hopping	2400.0	-41.8	PEAK	100.0	1.0	-19.0	22.8
hopping	hopping	2483.5	-54.0	PEAK	100.0	1.3	-18.7	35.3

Remark: Please see next sub-clause for the measurement plot.

4.6.4 Measurement Plot (showing the highest value, "worst case")

Radio Technology = Bluetooth BDR, Operating Frequency = low, Band Edge = low

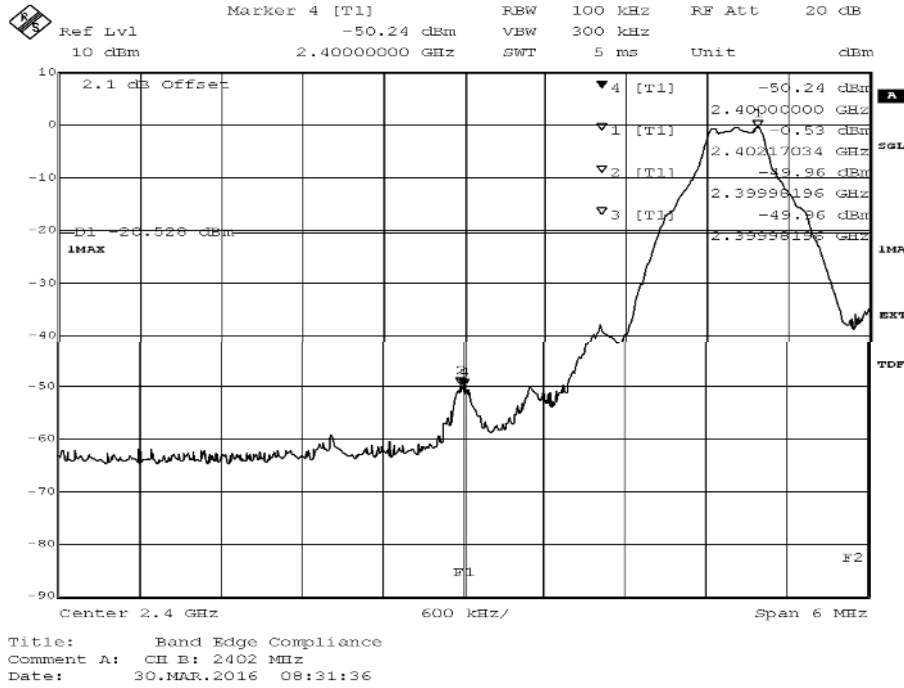

Radio Technology = Bluetooth EDR 2, Operating Frequency = low, Band Edge = low

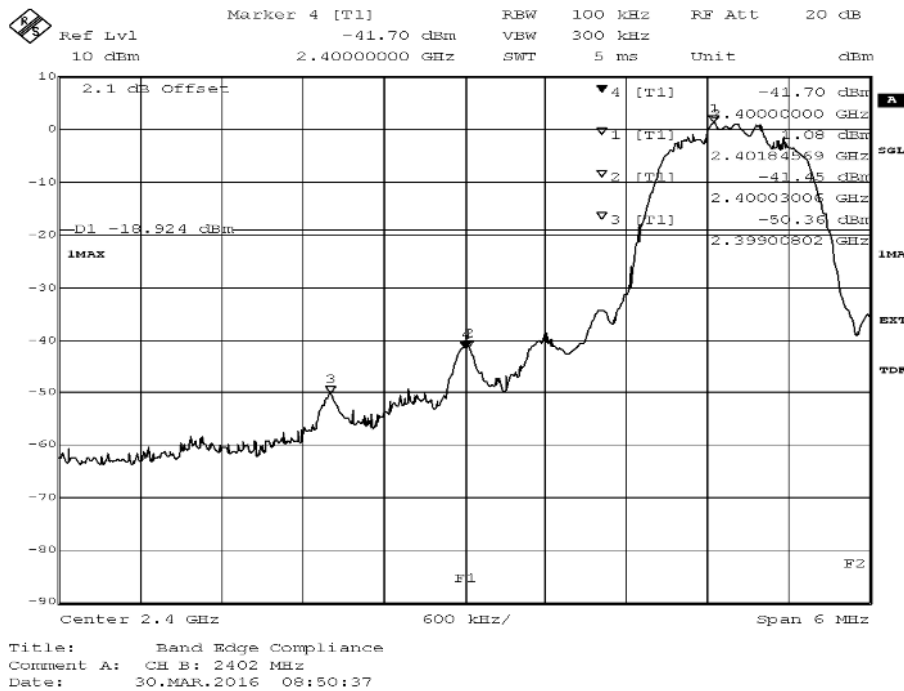

4.6.5 Test Equipment used

Regulatory Bluetooth RF Test Solution

4.7 Band Edge Compliance Radiated

Standard **47 CFR CHAPTER I FCC PART 15 Subpart C §15.247**

The test was performed according to: ANSI C63.10

4.7.1 Test Description

Please see test description for the test case "Spurious Radiated Emissions"

4.7.2 Test Requirements / Limits

A) FCC

FCC Part 15 Subpart E, §15.407 (b)(1)

For transmitters operating in the 5150–5250 MHz band:

Limit: –27 dBm/MHz EIRP outside of the band 5150–5350 MHz.

FCC Part 15 Subpart E, §15.407 (b)(2)

For transmitters operating in the 5250–5350 MHz band:

Limit: –27 dBm/MHz EIRP outside of the band 5150–5350 MHz.

FCC Part 15 Subpart E, §15.407 (b)(3)

For transmitters operating in the 5470–5725 MHz band:

Limit: –27 dBm/MHz EIRP outside of the band 5470–5725 MHz.

FCC Part 15 Subpart E, §15.407 (b)(4)

For transmitters operating in the 5725–5850 MHz band:

Limit: –17 dBm/MHz EIRP within the frequency ranges 5715–5725 and 5850–5860 MHz.

B) IC

Different frequency bands and limits apply, as compared to the FCC requirements.

RSS-247, 6.2 (1), Emissions outside the band 5150-5250 MHz, indoor operation only:

Limit: –27 dBm/MHz EIRP outside of the band 5150–5250 MHz.

RSS-247, 6.2 (2), Emissions outside the band 5250-5350 MHz:

Limit: –27 dBm/MHz EIRP outside of the band 5250–5350 MHz.

RSS-247, 6.2 (3), Emissions outside the bands 5470-5600 MHz and 5650-5725 MHz:

Limit: –27 dBm/MHz EIRP outside of the band 5470–5725 MHz.

Note: No operation is permitted for the frequency range 5600–5650 MHz.

RSS-247, 6.2 (4), Emissions outside the band 5725-5825 MHz:

Limit: –17 dBm/MHz EIRP within the frequency ranges 5715–5725 and 5825–5835 MHz.

C) FCC & IC

FCC Part 15 Subpart E, §15.405

The provisions of §§ 15.203 and 15.205 are included.

§15.407 (b)(6)

Unwanted emissions below 1 GHz must comply with the general field strength limits set forth in § 15.209.

§15.407 (b)(7)

The provisions of §15.205 apply to intentional radiators operating under this section

For band edges connected to a restricted band, the limits are specified in Section 15.209(a)

FCC Part 15, Subpart C, §15.209, Radiated Emission Limits

Frequency in MHz	Limit (µV/m)	Measurement distance (m)	Limits (dBµV/m)
0.009 – 0.49	2400/F(kHz)@300m	3	(48.5 – 13.8)@300m
0.49 – 1.705	24000/F(kHz)@30m	3	(33.8 – 23.0)@30m
1.705 – 30	30@30m	3	29.5@30m

The measured values are corrected with an inverse linear distance extrapolation factor (40 dB/decade) according FCC 15.31 (2).

Frequency in MHz	Limit (µV/m)	Measurement distance (m)	Limits (dBµV/m)
30 – 88	100@3m	3	40.0@3m
88 – 216	150@3m	3	43.5@3m
216 – 960	200@3m	3	46.0@3m
960 – 26000	500@3m	3	54.0@3m
26000 – 40000	500@3m	1	54.0@3m

The measured values above 26 GHz are corrected with an inverse linear distance extrapolation factor (20 dB/decade).

§15.35(b) ..., there is also a limit on the radio frequency emissions, as measured using instrumentation with a peak detector function, corresponding to 20 dB above the maximum permitted average limit....

Used conversion factor: $\text{Limit (dB}\mu\text{V/m)} = 20 \log (\text{Limit } (\mu\text{V/m})/1\mu\text{V/m)}$

4.7.3 Test Protocol

Ambient temperature: 22–23 °C

Air Pressure: 1001–1002 hPa

Humidity: 34–38 %

BT GFSK (1-DH1)

Ch. No.	Ch. Center Freq. [MHz]	Band Edge Freq. [MHz]	Spurious Level [dB μ V/m]	Detector	RBW [kHz]	Limit [dB μ V/m]	Margin to Limit [dB]	Limit Type
78	2480.0	2483.5	50.8	PEAK	1000.0	74.0	23.2	BE
78	2480.0	2483.5	46.4	AV	1000.0	54.0	7.6	BE

BT π /4 DQPSK (2-DH1)

Ch. No.	Ch. Center Freq. [MHz]	Band Edge Freq. [MHz]	Spurious Level [dB μ V/m]	Detector	RBW [kHz]	Limit [dB μ V/m]	Margin to Limit [dB]	Limit Type
78	2480.0	2483.5	54.4	PEAK	1000.0	74.0	19.6	BE
78	2480.0	2483.5	46.8	AV	1000.0	54.0	7.2	BE

BT 8-DPSK (3-DH1)

Ch. No.	Ch. Center Freq. [MHz]	Band Edge Freq. [MHz]	Spurious Level [dB μ V/m]	Detector	RBW [kHz]	Limit [dB μ V/m]	Margin to Limit [dB]	Limit Type
78	2480.0	2483.5	52.6	PEAK	1000.0	74.0	21.4	BE
78	2480.0	2483.5	46.9	AV	1000.0	54.0	7.1	BE

Remark: Please see next sub-clause for the measurement plot.

4.7.4 Measurement Plot (showing the highest value, "worst case")

Radio Technology = Bluetooth EDR 3, Operating Frequency = high, Band Edge = high

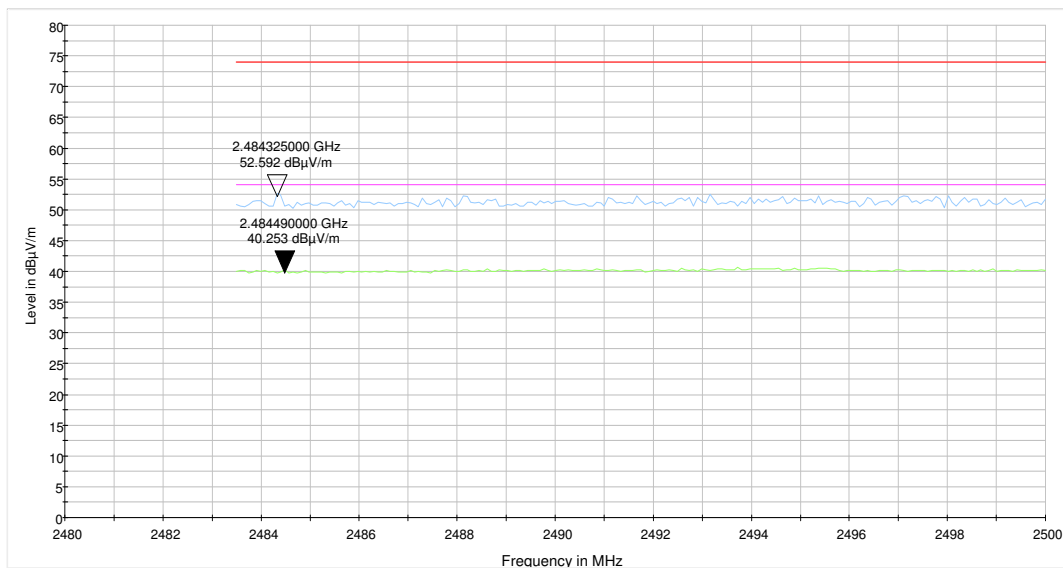

Radio Technology = Bluetooth EDR 2, Operating Frequency = high, Band Edge = high

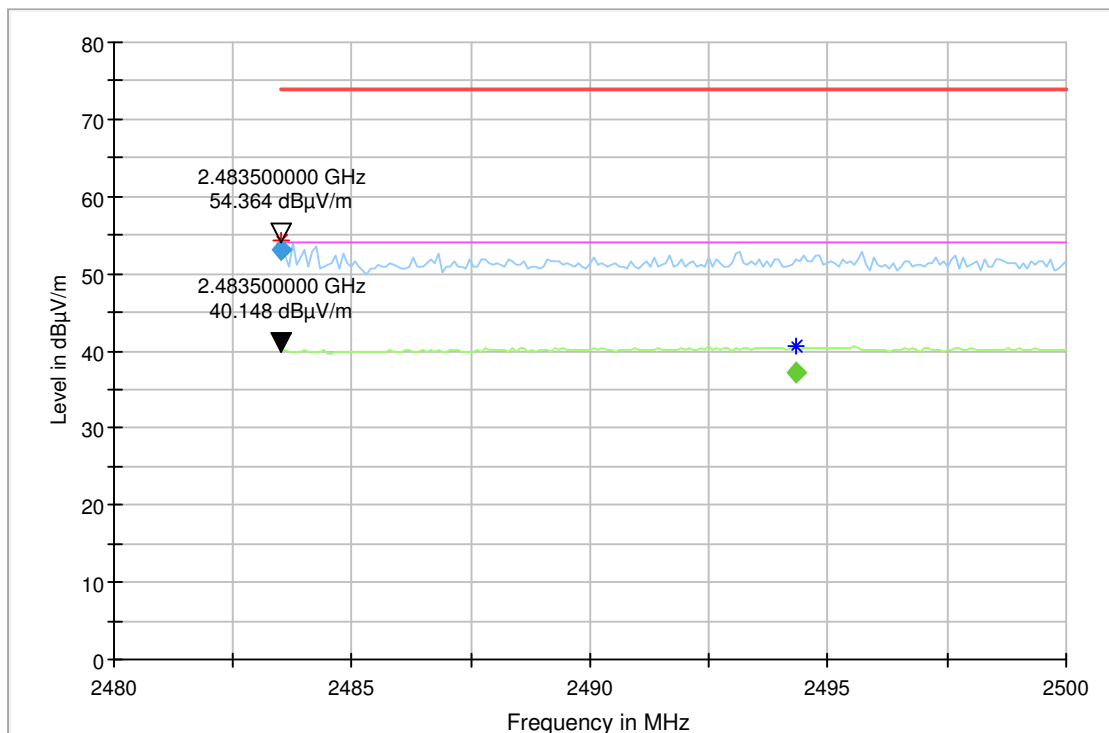

Radio Technology = Bluetooth BDR, Operating Frequency = high, Band Edge = high

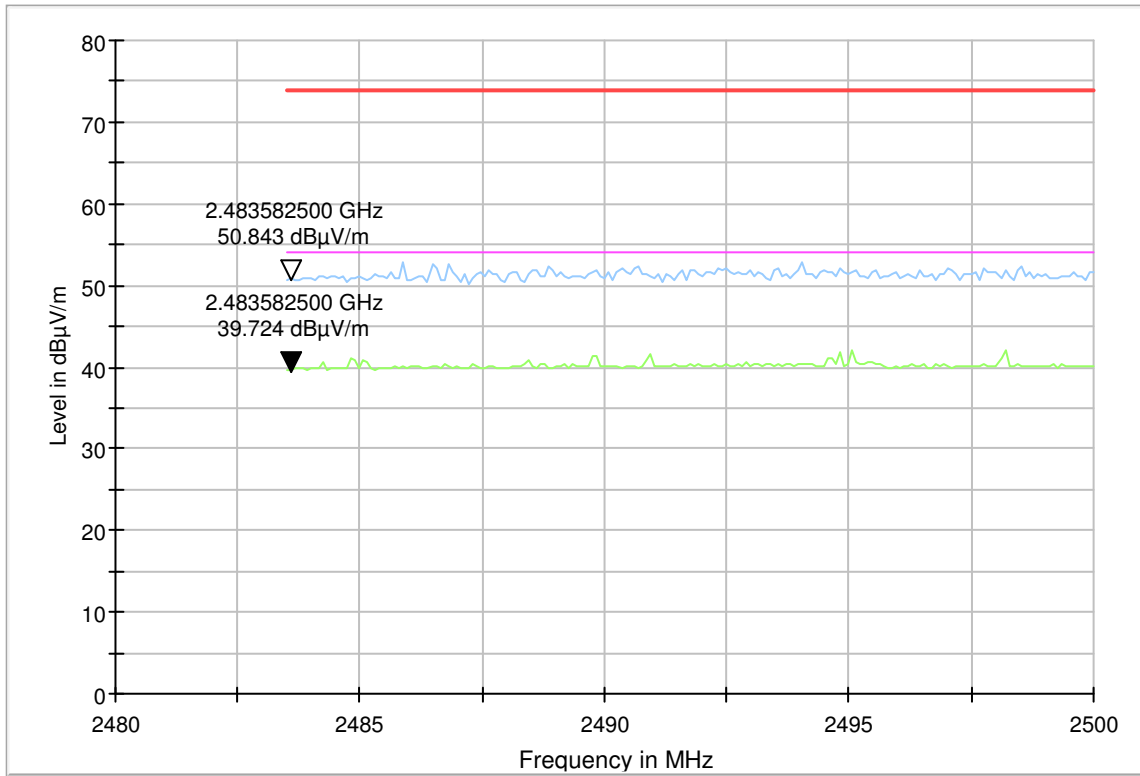

4.7.5 Test Equipment used

Radiated Emissions

4.8 Channel Separation

Standard **47 CFR CHAPTER I FCC PART 15 Subpart C §15.247**

The test was performed according to: ANSI C63.10

4.8.1 Test Description

The Equipment Under Test (EUT) was set up to perform the channel separation measurements. The channel separation is independent from the modulation pattern.

The EUT was connected to the spectrum analyzer via a short coax cable with a known loss.

Analyzer settings:

- Detector: Peak
- Trace: Maxhold
- Span: appr. 3 x OBW
- Centre Frequency: a mid frequency of the used band
- Resolution Bandwidth (RBW): appr. 3 % of channel spacing
- Video Bandwidth (VBW): 3 x RBW
- Sweep Time: 5 ms
- Sweeps: 2000

The technology depending measurement parameters can be found in the measurement plot.

4.8.2 Test Requirements / Limits

FCC Part 15, Subpart C, §15.247 (a) (1)

Frequency hopping systems shall have hopping channel carrier frequencies separated by a minimum of 25 kHz or the 20 dB bandwidth of the hopping channel, whichever is greater. Alternatively, frequency hopping systems operating in the 2400–2483.5 MHz band may have hopping channel carrier frequencies that are separated by 25 kHz or two-thirds of the 20 dB bandwidth of the hopping channel, whichever is greater, provided the systems operate with an output power no greater than 125 mW. The system shall hop to channel frequencies that are selected at the system hopping rate from a pseudo randomly ordered list of hopping frequencies. Each frequency must be used equally on the average by each transmitter. The system receivers shall have input bandwidths that match the hopping channel bandwidths of their corresponding transmitters and shall shift frequencies in synchronization with the transmitted signals.

4.8.3 Test Protocol

Ambient temperature: 23 °C
 Air Pressure: 1019 hPa
 Humidity: 41 %

Radio Technology	Channel Separation [kHz]	Limit [kHz]	Margin to Limit [kHz]
BT GFSK (1-DH1)	1000.0	685.6	314.4

Remark: Please see next sub-clause for the measurement plot.

4.8.4 Measurement Plot (showing the highest value, "worst case")

Radio Technology = Bluetooth BDR

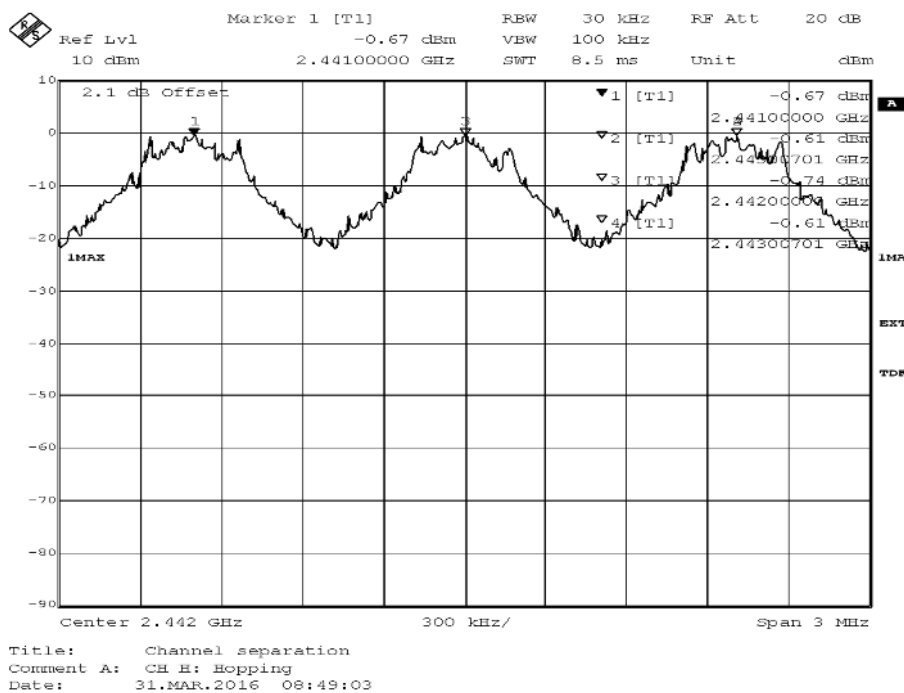

4.8.5 Test Equipment used

Regulatory Bluetooth RF Test Solution

4.9 Dwell Time

Standard **47 CFR CHAPTER I FCC PART 15 Subpart C §15.247**

The test was performed according to: ANSI C63.10

4.9.1 Test Description

The Equipment Under Test (EUT) was set up to perform the dwell time measurements. The dwell time is independent from the modulation pattern. The dwell time is calculated by:

The EUT was connected to the spectrum analyzer via a short coax cable with a known loss.

Dwell time = time slot length * hop rate / number of hopping channels * 31.6 s

with:

- hop rate = $1600 * 1/s$ for DH1 packets = 1600 s⁻¹
- hop rate = $1600/3 * 1/s$ for DH3 packets= 533.33 s⁻¹
- hop rate = $1600/5 * 1/s$ for DH5 packets= 320 s⁻¹
- number of hopping channels = 79
- 31.6 s = 0.4 seconds multiplied by the number of hopping channels = 0.4 s * 79

The highest value of the dwell time is reported.

Analyzer settings:

- Center Frequency: mid channel frequency
- Span: Zero span
- Detector: Peak
- Trace: Maxhold
- Resolution Bandwidth (RBW): ≤ channel separation
- Trigger: Video

4.9.2 Test Requirements / Limits

For the band: 902 – 928 MHz
FCC Part 15, Subpart C, §15.247 (a) (1) (i)

If the 20 dB bandwidth of the hopping channel is less than 250 kHz the average time of occupancy on any frequency shall not be greater than 0.4 seconds within a 20 second period.

If the 20 dB bandwidth of the hopping channel is 250 kHz or greater, the average time of occupancy on any frequency shall not be greater than 0.4 seconds within a 10 second period.

For the band: 5725 – 5850 MHz
FCC Part 15, Subpart C, §15.247 (a) (1) (ii)

The average time of occupancy on any frequency shall not be greater than 0.4 seconds within a 30 second period.

For the frequency band 2400 – 2483.5 MHz:
FCC Part 15, Subpart C, §15.247 (a) (1) (iii)

...The average time of occupancy on any channel shall not be greater than 0.4 seconds within a period of 0.4 seconds multiplied by the number of hopping channels employed. Since the Bluetooth technology uses 79 channels this period is calculated to be 31.6 seconds.

4.9.3 Test Protocol

Ambient temperature: 23 °C
Air Pressure: 1019 hPa
Humidity: 41 %

Radio Technology	Time Slot Length [ms]	Dwell Time [ms]	Limit [s]	Margin to Limit [ms]
BT GFSK (1-DH5)	2.9	374.4	0.4	25.6

Remark: Please see next sub-clause for the measurement plot.

4.9.4 Measurement Plot (showing the highest value, "worst case")

Radio Technology = Bluetooth BDR

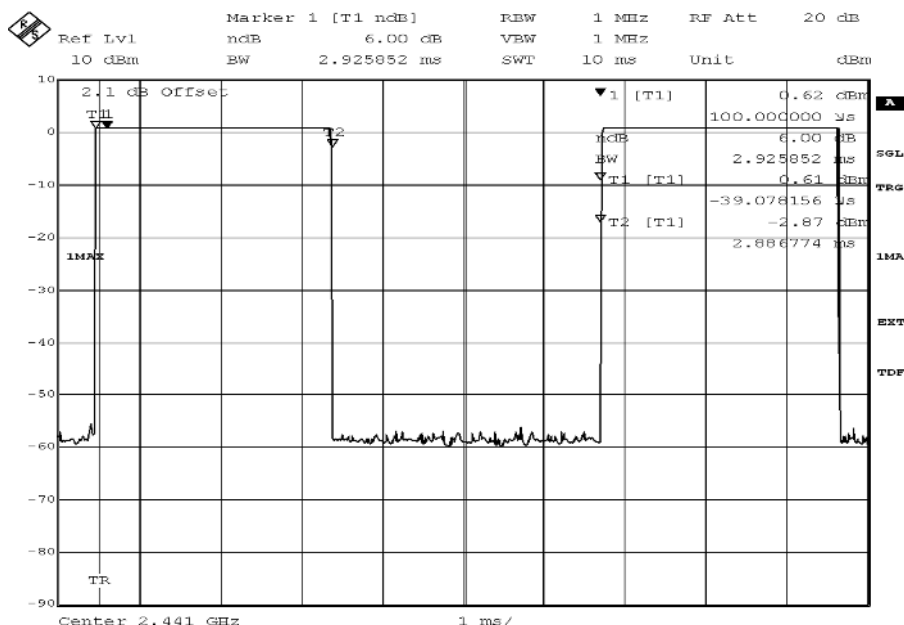

Title: Dwell time
Comment A: CH M: 2441 MHz
Date: 31.MAR.2016 08:31:41

4.9.5 Test Equipment used

Regulatory Bluetooth RF Test Solution

4.10 Number of Hopping Frequencies

Standard **47 CFR CHAPTER I FCC PART 15 Subpart C §15.247**

The test was performed according to: ANSI C63.10

4.10.1 Test Description

The Equipment Under Test (EUT) was set up to perform the number of hopping frequencies measurement. The number of hopping frequencies is independent from the modulation pattern.

The EUT was connected to the spectrum analyzer via a short coax cable with a known loss.

Analyzer settings:

- Detector: Peak
- Trace: Maxhold
- Centre frequency: 2442 MHz
- Frequency span: Frequency band of operation
- Resolution Bandwidth (RBW): < 30 % of channel spacing or 20 dB bandwidth (whichever is maller)
- Video Bandwidth (VBW): 3 x RBW
- Sweep Time: 5 ms
- Sweeps: 2000

The technology depending measurement parameters can be found in the measurement plot.

4.10.2 Test Requirements / Limits

For the band: 902 – 928 MHz
FCC Part 15, Subpart C, §15.247 (a) (1) (i)

If the 20 dB bandwidth of the hopping channel is less than 250 kHz, the system shall use at least 50 hopping frequencies.

If the 20 dB bandwidth of the hopping channel is 250 kHz or greater, the system shall use at least 25 hopping frequencies

For the band: 5725 – 5850 MHz
FCC Part 15, Subpart C, §15.247 (a) (1) (ii)

Frequency hopping systems operating in the 5725-5850 MHz band shall use at least 75 hopping frequencies.

For the band: 2400 – 2483.5 MHz
FCC Part 15, Subpart C, §15.247 (a) (1) (iii)

Frequency hopping systems in the 2400-2483.5 MHz band shall use at least 15 channels.

4.10.3 Test Protocol

Ambient temperature: 23 °C
 Air Pressure: 1019 hPa
 Humidity: 41 %

Radio Technology	Number of Hopping Frequencies	Limit	Margin to Limit
BT GFSK (1-DH1)	79.0	15.0	64.0

Remark: Please see next sub-clause for the measurement plot.

4.10.4 Measurement Plot (showing the highest value, "worst case")

Radio Technology = Bluetooth BDR

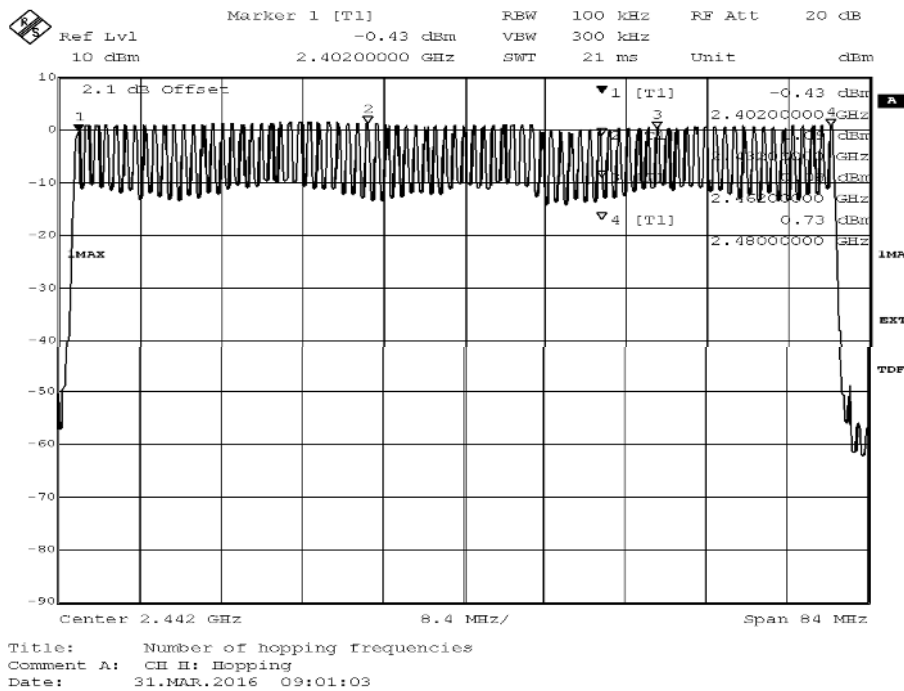

4.10.5 Test Equipment used

Regulatory Bluetooth RF Test Solution

5 Test Equipment

1 Regulatory Bluetooth RF Test Solution Regulatory Bluetooth RF Tests

Ref.No.	Device Name	Description	Manufacturer	Serial Number	Calibration Due
1.1	CBT	IL BT RF Test Solution	Rohde & Schwarz GmbH & Co. KG	100302	2016-08-20
1.2	EX520	Digital Multimeter 12 (Multimeter)	Extech Instruments Corp	05157876	2018-02-03
1.3	SMIQ03B	Options: B5 B11 B19 B20 B50 Battery Pack	Rohde & Schwarz GmbH & Co. KG	832870/017	2016-06-21
1.4	Datum MFS	Rubidium Frequency Normal MFS	Datum GmbH	002	2016-08-25
1.5	FSIQ26	IL BT RF Test Solution Ratingen 1119.6001.26	Rohde & Schwarz GmbH & Co. KG	832695/007	2016-08-28
1.6	NRVD	Powermeter	Rohde & Schwarz GmbH & Co. KG	832025/059	2016-08-19
1.7	TOCT Switching Unit		7 layers, Inc	040107	
1.8	Opus10 THI (8152.00)	T/H Logger 15	Lufft Mess- und Regeltechnik GmbH	13985	2017-03-10
1.9	NRV Z1 A	Power Sensor	Rohde & Schwarz GmbH & Co. KG	832279/013	2016-08-18
1.10	ADU 200 Relay Box 7	used for automated testing (EMMI) only	Ontrak Control Systems Inc	A04380	
1.11	R&S CBT	Bluetooth Signalling Unit	Rohde & Schwarz	100589	2018-01-21
1.12	KWP 120/70	Temperature Chamber Weiss 01	Weiss	59226012190010	2018-03-09
1.13	NGSM 32/10	Power Supply	Rohde & Schwarz GmbH & Co. KG	2725	2017-06-22
1.14	SMP02	Signal Generator	Rohde & Schwarz GmbH & Co. KG	829076/017	2016-04-18

2 Radiated Emissions

Lab to perform radiated emission tests

Ref.No.	Device Name	Description	Manufacturer	Serial Number	Calibration Due
2.1	3160-09	Standard Gain / Pyramidal Horn Antenna 26.5 GHz	EMCO Elektronik GmbH	00083069	
2.2	WHKX 7.0/18G-8SS	High Pass Filter	Wainwright	09	
2.3	Fully Anechoic Room	8.80m x 4.60m x 4.05m (l x w x h)	Albatross Projects	P26971-647-001-PRB	
2.4	AM 4.0	Antenna mast	Maturo GmbH	AM4.0/180/11920513	
2.5	ESR 7	EMI Receiver / Spectrum Analyzer	Rohde & Schwarz	101424	2016-11-13
2.6	Anechoic Chamber	10.58 x 6.38 x 6.00 m ³	Frankonia	none	2017-01-09
2.7	ESIB 26	Spectrum Analyzer	Rohde & Schwarz	830482/004	2017-12-08
2.8	Tilt device Maturo (Rohacell)	Antrieb TD1.5-10kg	Maturo GmbH	TD1.5-10kg/024/3790709	
2.9	AS 620 P	Antenna mast	HD GmbH	620/37	
2.10	NRV-Z1	Sensor Head A	Rohde & Schwarz	827753/005	2016-05-11
2.11	JS4-18002600-32-5P	Broadband Amplifier 18 GHz - 26 GHz	Miteq	849785	
2.12	JS4-00101800-35-5P	Broadband Amplifier 30 MHz - 18 GHz	Miteq	896037	
2.13	HL 562	Ultralog new biconicals	Rohde & Schwarz GmbH & Co. KG	830547/003	2018-06-30
2.14	Opus10 THI (8152.00)	ThermoHygro Datalogger 12 (Environ)	Lufft Mess- und Regeltechnik GmbH	12482	2017-03-10
2.15	JS4-00102600-42-5A	Broadband Amplifier 30 MHz - 26 GHz	Miteq	619368	
2.16	HFH2-Z2	Loop Antenna	Rohde & Schwarz GmbH & Co. KG	829324/006	2017-11-27
2.17	FSW 43	Spectrum Analyzer	Rohde & Schwarz	103779	2016-11-17
2.18	Opus10 TPR (8253.00)	ThermoAirpressure Datalogger 13 (Environ)	Lufft Mess- und Regeltechnik GmbH	13936	2017-02-27

Ref.No.	Device Name	Description	Manufacturer	Serial Number	Calibration Due
2.19	Chroma 6404	AC Power Source	Chroma ATE INC.	64040001304	
2.20	3160-10	Standard Gain / Pyramidal Horn Antenna 40 GHz	EMCO Elektronik GmbH	00086675	
2.21	HF 907	Double-ridged horn	Rohde & Schwarz GmbH & Co. KG	102444	2018-05-11
2.22	DE 325	Dreheinheit	HD GmbH		

3 Conducted Emissions

Shielded Room 02

Ref.No.	Device Name	Description	Manufacturer	Serial Number	Calibration Due
3.1	ESH 3-Z5	Two-Line V-Network	Rohde & Schwarz	828304/029	
3.2	ESR 7	EMI Receiver / Spectrum Analyzer	Rohde & Schwarz	101424	2016-11-13
3.3	Opus10 THI (8152.00)	ThermoHygro Datalogger 02 (Environ)	Lufft Mess- und Regeltechnik GmbH	7489	2017-02-27
3.4	ESH 3-Z5	Two-Line V-Network	Rohde & Schwarz	829996/002	
3.5	Opus10 TPR (8253.00)	ThermoAirpressure Datalogger 13 (Environ)	Lufft Mess- und Regeltechnik GmbH	13936	2017-02-27
3.6	Chroma 6404	AC Power Source	Chroma ATE INC.	64040001304	

6 Setup Drawings

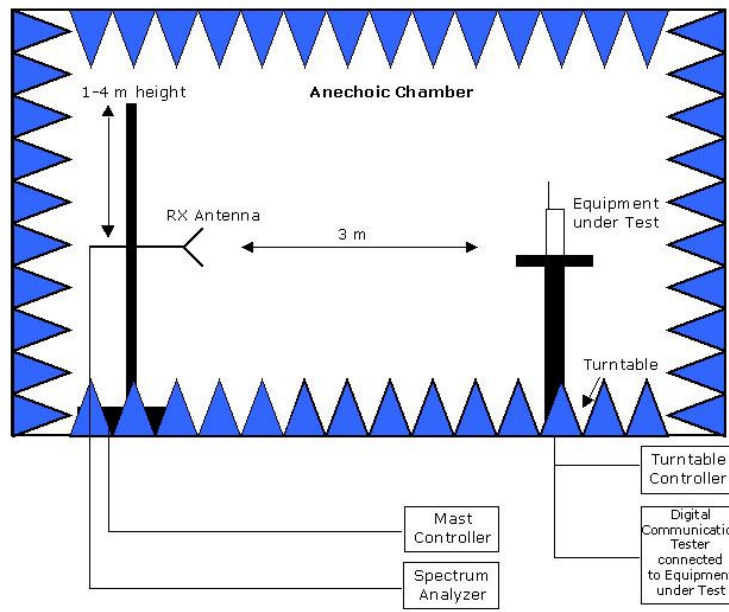

Remark: Depending on the frequency range suitable antenna types, attenuators or preamplifiers are used.

Drawing 1: Setup in the Anechoic chamber. For measurements below 1 GHz the ground was replaced by a conducting groundplane.

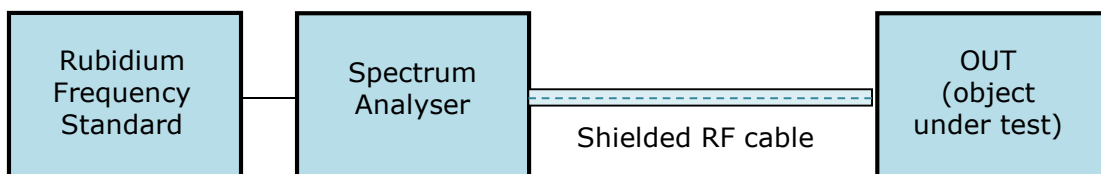

Drawing 2: Setup for conducted radio tests.

7 Measurement Uncertainties

Test Case	Parameter	Uncertainty
AC Power Line	Power	± 3.4 dB
Field Strength of spurious radiation	Power	± 5.5 dB
6 dB / 26 dB / 99% Bandwidth	Power Frequency	± 2.9 dB ± 11.2 kHz
Conducted Output Power	Power	± 2.2 dB
Band Edge Compliance	Power Frequency	± 2.2 dB ± 11.2 kHz
Frequency Stability	Frequency	± 25 Hz
Power Spectral Density	Power	± 2.2 dB

8 Photo Report

Please see separate photo report.