

8

7

6

5

4

3

2

1

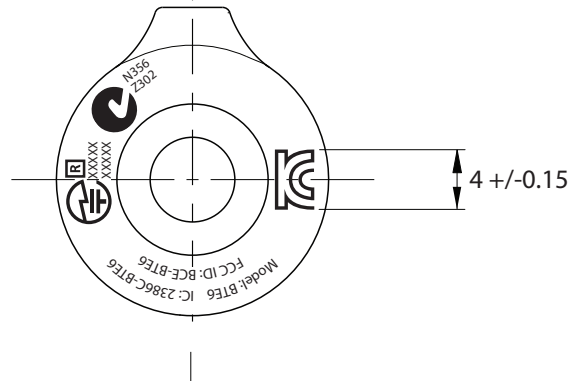
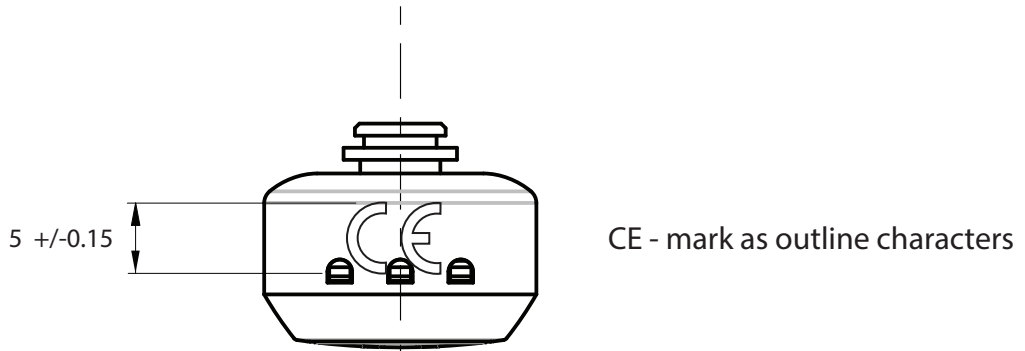

Align pad print around centre of item

Use CE mark as reference, to ensure right dimensions

Use KCC mark as reference, to ensure right dimensions

Use layout file as input for pad print

CONFIDENTIALITY NOTICE:

This document is the property of GN A/S and must be treated as confidential. The document must not be used, or disclosed to any third party, without written permission of GN A/S. Copyright © 2007 GN A/S. All rights reserved.

Process control dimensions are marked:

IQC/OQC Characteristics for Evaluation:

1

Date of Change:	Description of Change:	Responsible:
-----------------	------------------------	--------------

	Matr. Spec: (See B.O.M.)	Cosmetic Standard: GSC.ST.00002	Issued by:	Issued:	Drawing Scale:	Size:
	Matr. type:	Part Marking.: GSC.PR.00102	JJO	13.12.2012	2:1	A4
	3D file name:	Document Status:	Approved by:	Date Approved:	Projection:	

Description:	Document No:	Doc. Revision:	Units:	Page No:
Pad Print Placement, HS, Copenhagen	50-06162	D	mm	1 of 1

A	B	C	D	E	F
---	---	---	---	---	---