



A335W USER MANUAL

東訊股份有限公司 **Tecom Co; Ltd**
新竹市科學園區研發二路 23 號
23, R&D Road 2, Science-Based Industrial Park
Hsin-Chu Taiwan R.O.C.

1 Marketing Definition and Requirements

This section shall contain consolidation of the process in product marketing. It is acceptable that spec can be a bit loose in this chapter but subsequent chapters leave no room for loose specs.

1.1 General Description

The product is a Bluetooth-enabled USB audio device intended to be used as an accessory for standard industry PCs. It is designed to work with BT headsets as long as they adhere to the Bluetooth 2.0+EDR specification supporting the headset Bluetooth profile than bi-directional audio streaming.

The product targets primarily the ingenuous consumer or first-time headset user who appreciates a hassle free truly PnP solution which operates instantly without requiring neither configuration nor any installation of software, driver etc.

1.1.1 Market Problem

Due to an increasing interest in convenient VoIP services on standard industry PCs, where headsets are a prerequisite, there is a growing demand for inexpensive, easy to install and easy to use cordless headsets solutions.

1.1.2 Product Problem

Originally BT headset intended to be used with Mobile phones supporting voice services only. Existing BT implementations on PCs consist of built-in BT components or external accessories, like USB dongles, with BT functions and additional BT SW. This PC BT implementation compared to built-in BT in telephone handsets is much more complex (normally supporting many more profiles), and more focused on data use instead of voice services, even if those solutions are capable supporting, e.g. headset or head-free profile.

1.1.3 Technology Problem

For BT support in a PC environment a BT Host protocol stack/SW needs to be operated on the PC. This software needs to be installed, managed and launched by the user on the PC before the headset can be paired and used for e.g. VoIP services. This kind of use is much more complex and challenging for the user compared to the BT telephone implementation/use case.

1.2 Key Features, Benefits and USPs

This section is informative. This is a list of new, essential and unique features which differentiates the product.

Feature	Benefit, explanation, comment
Mono and Stereo capabilities on same hardware platform	Core unit performs as a mono / voice solution (=Leopard). Firmware is user upgradeable to additional stereo operation. In this state the product converts into a mono/voice plus stereo streaming device depending on BT HS capabilities (=Swan).
Ease of use	Leopard (and Swan) is a truly PnP solution not requiring any specific driver or installation of dedicated software for basic operation. Even though Leopard is state of the art in terms of MS Windows operating system (XP or higher) support with MS standard USB and audio drivers.

VoIP client / softphone support	Implementing the newly developed GN USB standard the device will be compliant to the Microsoft Unified Communications (UC) standard. A variety of VoIP clients and/or softphones using the current GN USB HID commands (8120, 9300 series) will also provide basic headset supported without additional customization. The product is fully compliant with GN's PC software developments and SDKs (Hector).
Other key functionality:	
Auto pairing	<ul style="list-style-type: none"> • Device enters into auto pairing mode on 1st time use / connection

Table 1 - Key features

1.3 Features & Characteristics requirements

This section is based on the marketing product definition sheet. Details of how functions shall operate must be presented in chapter 3. .

For details please refer to chapter 3 (functional requirements) and 4 (operational requirements).

Functional

Physical Characteristics		
	Connector	USB
	Size	App. 70mm (L) x 18mm (W) x 8mm (H)
	Weight	<10 g
Mechanical features		
	Button key	Pairing button
	Surface treatment	No paint applied
	Materials – general characteristics	Mid-range quality feel
MMI features		
<i>Controls - buttons, etc.</i>		
	Pairing button	Large, centered, tactile feeling, supporting only pairing
<i>Indicators - LEDs, display, etc.</i>		
	On, pairing, connected	a.) 1xBlue LED (=Leopard) b.) 1xBlue LED (=Swan)
<i>Connectors</i>		
	USB connector	
Software features		
<i>Bluetooth specific features</i>		
	Applicable standard	BT 2.0+EDR
	Profiles	HS, HF

	Number of trusted devices in the trusted device list	Normally 1 set
<i>USB software features</i>		
	USB device classes	<ul style="list-style-type: none"> • USB Audio device • USB composite device • USB Telephony device
<i>Other software features</i>		
	Power-up behaviour	First power up: goes into the pairing mode Next power up: try to reconnect to the last connected device for 1 min.
	Downloadable software	Software firmware updates and upgrades possible via the USB port
Performance characteristics		
<i>Electrical, RF</i>		
	RF	Bluetooth class 1 device
	Power Management	HS link management optimized maximum headset standby / talk time

Table 2 - Characteristics

Operational

Environmental targets		
	Operating temperature	-10 - +60
	Storage temperature	-30 - +80

Table 3 - Operational characteristics

2.1 Model name

Product	Bluetooth PnP Audio USB Class1 Dongle – Leopard
Product ID	261-251531R

2.2 Firmware

Leopard FW release 0.08

2.3 Hardware

2.3.1 Block Diagram

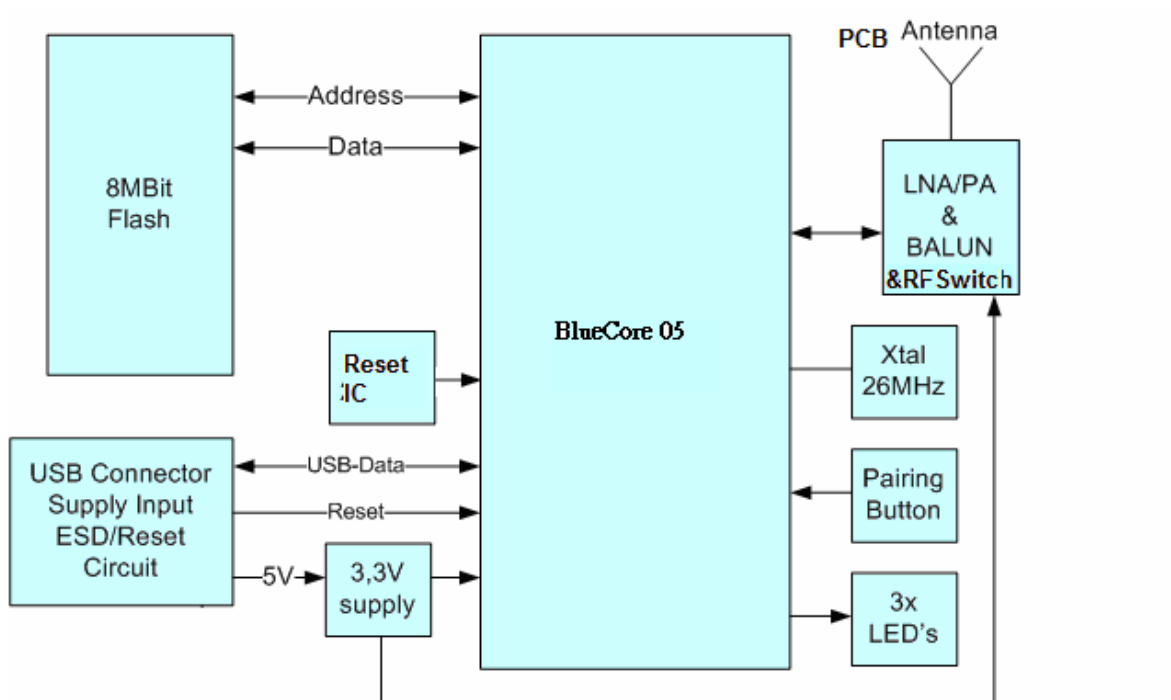

2.3.2 PCB Version

PN: 613-022651R Ver: A

3.1 Physical Dimension and Component Placement

With USB connector: 51 mm x 14.05 mm
 W/O USB connector: 35 mm x 14.05 mm

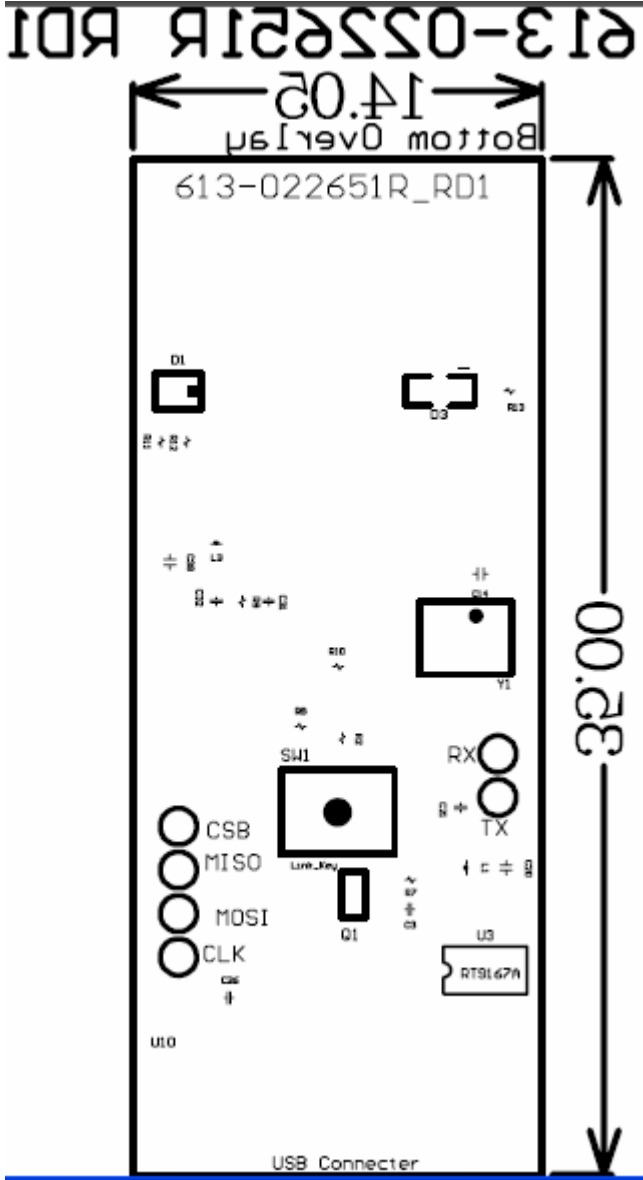

613-U22651R RDI

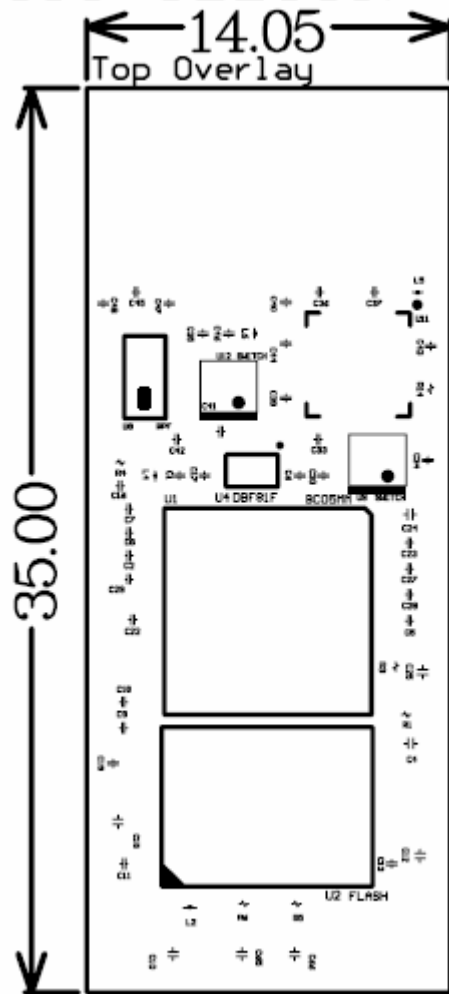

3.2 RF Design Specifications

Transmitter

	Min	Typ	Max	Bluetooth Spec	Unit
Maximum RF transmit power	13	15	16	+4 ~ +20	dBm
RF Power control range	-	>20	-	≥ 16	dB
20dB bandwidth for modulated carrier	-	715	-	≤ 1000	kHz
Adjacent channel transmit power $F = F_0 \pm 2\text{MHz}$	-	-28	-	≤ -20	dBm
Adjacent channel transmit power $F = F_0 \pm 3\text{MHz}$	-	-35	-	≤ -40	dBm
Adjacent channel transmit power $F > F_0 \pm 3\text{MHz}$	-	-43	-	≤ -40	dBm
$\Delta f_{1\text{avg}}$ Maximum Modulation	-	165	-	$140 < \Delta f_{1\text{avg}} < 175$	kHz
$\Delta f_{2\text{avg}}$ Minimum Modulation	-	148	-	≥ 115	kHz
$\Delta f_{2\text{avg}} / \Delta f_{1\text{avg}}$	-	0.9	-	≥ 0.80	-
Initial carrier frequency tolerance	-	≤ 15	-	± 75	kHz
Drift Rate	-	≤ 15	-	≤ 20	kHz/50 μs
Drift (single slot packet)	-	≤ 15	-	≤ 25	kHz
Drift (five slot packet)	-	≤ 15	-	≤ 40	kHz
2nd Harmonic content	-	≤ -33	-	≤ -30	dBm
3rd Harmonic content	-	≤ -33	-	≤ -30	dBm

Receiver

	Frequency	Min	Typ	Max	Bluetooth Spec	Unit
Sensitivity at 0.1% BER for all packet type	2.402 GHz	<-85	-88	>-90	≤ -70	dBm
	2.441 GHz	<-85	-88	>-90		
	2.480 GHz	<-85	-88	>-90		
Maximum received signal at 0.1% BER		-	≥ -20	-	≥ -20	dBm

Warning statements

THIS DEVICE COMPLIES WITH PART 15 OF THE FCC RULES. OPERATION IS SUBJECT TO THE FOLLOWING TWO CONDITIONS:

- (1) THIS DEVICE MAYNOT CAUSE HARMFUL INTERFERENCE, AND
- (2) THIS DEVICE MUST ACCEPT ANY INTERFERENCE RECEIVED, INCLUDING INTERFERENCE THATMAY CAUSE UNDESIREED OPERATION.

NOTE: THE MANUFACTURER IS NOT RESPONSIBLE FOR ANY RADIO OR TV INTERFERENCE CAUSED BY UNAUTHORIZED MODIFICATIONS TO THIS EQUIPMENT. SUCH MODIFICATIONS COULD VOID THE USER'S AUTHORITY TO OPERATE THE EQUIPMENT.