

8  
7  
6  
5  
4  
3  
2

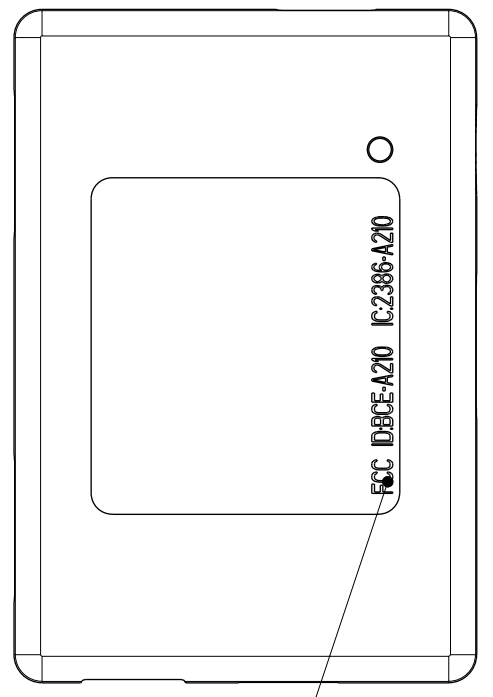

Font not critical.  
Font Height: 1.5 mm.  
Thickness: 0.05 mm.

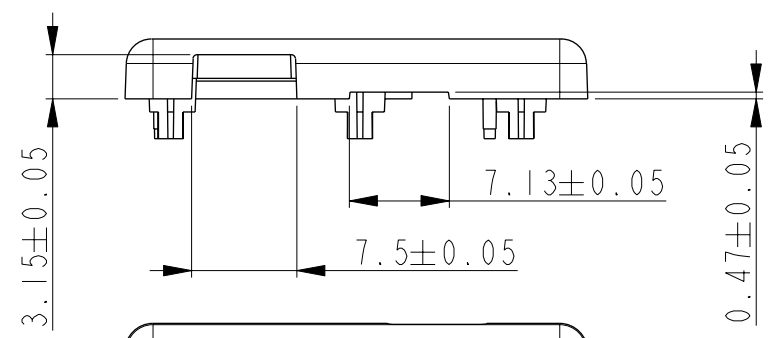
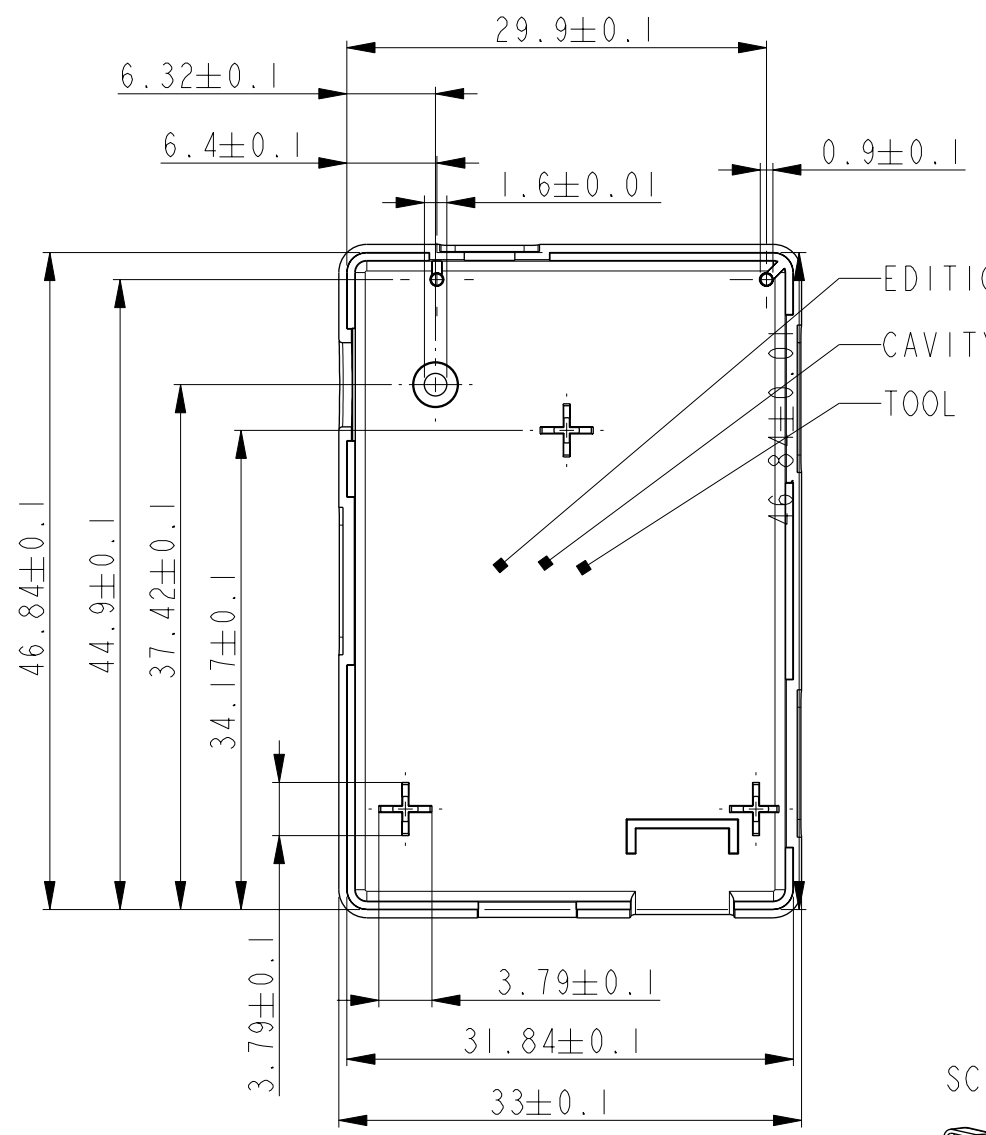
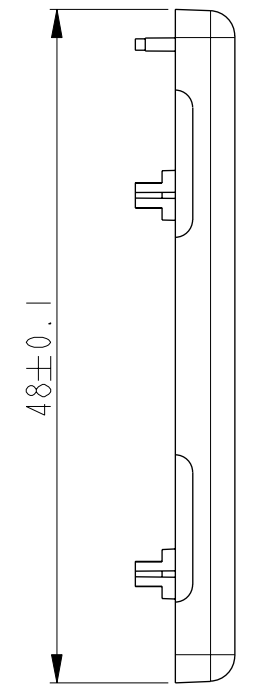
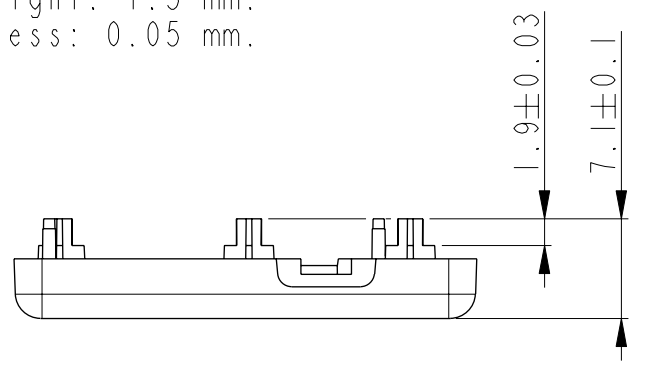

EDITION MARK ID AREA  
CAVITY MARK ID AREA  
TOOL ID MARK AREA

SCALE 1:1

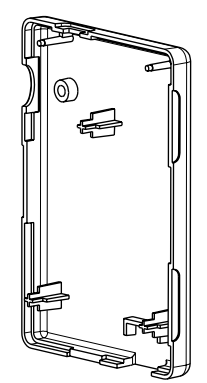

1	CERTIFICATE OF CONFORMANCE TO UL REQUIREMENTS MUST BE SUPPLIED WITH EACH DELIVERY OF THIS PART, SEE INSTRUCTION 0002-441	INDICATION OF EDITION MARK OF TOOL: DOTS $\varnothing$ 0.5 X 1 AMOUNT: 0
	TOOL IDENTIFICATION MARK: TOOL NUMBER:	INDICATION OF CAVITY MARK OF TOOL: LINES 0.1 x 0.5 x 1 AMOUNT:
	SURFACE FINISH:	MATERIAL TYPE.: MATERIAL SPEC.:

LAST UPDATED 02.08.2004

FIRST ISSUE DATE:	FIRST DRAWN BY: PFJ	FIRST APPR. BY: JLI	DRAWING NO.: 400-00421-00
ECO ISSUE DATE:	ECO DRAWN BY:	ECO APPR. BY:	
DESCRIPTION: <b>BOTTOM COVER</b>			PROJECTION:
ECO NO.:	MONK_BOTTOM_COVER	REVISION: 0	PAGE 1 OF 1 PAGES
© 2003 GN Netcom as. All rights reserved.			Scale: 2:1

A B C D E F G H