



Product Service

---

**Choose certainty.  
Add value.**

# Report On

Specific Absorption Rate Testing of the GN Netcom  
DECT 1900MHz Jabra PRO 9400 series Headset  
In accordance with OET 65



Product Service

TÜV Product Service Ltd, Octagon House, Concorde Way, Segensworth North,  
Fareham, Hampshire, United Kingdom, PO15 5RL  
Tel: +44 (0) 1489 558100. Website: [www.tuvps.co.uk](http://www.tuvps.co.uk)

**REPORT ON**

Specific Absorption Rate Testing of the GN Netcom  
DECT 1900MHz Jabra PRO 9400 series Headset  
In accordance with OET 65

Document 75906064 Report 02 Issue 2

May 2009

**PREPARED FOR**

TRaC-KTL  
Unit E  
South Orbital Trading Park  
Hendon Road  
Hull  
HU 1NJ

**PREPARED BY**

  
\_\_\_\_\_  
**N Grigsby**  
Senior Wireless Engineer

**APPROVED BY**

  
\_\_\_\_\_  
**M Jenkins**  
Authorised Signatory

**DATED**

19 May 2009

**This report has been up-issued to Issue 2 to correct typographical errors.**



## CONTENTS

Section	Page No
<b>1</b>	<b>REPORT SUMMARY ..... 3</b>
1.1	Introduction ..... 4
1.2	Brief Summary of Results ..... 5
1.3	Test Results Summary ..... 5
1.4	Product Information ..... 7
1.5	FCC Power measurements ..... 8
<b>2</b>	<b>TEST DETAILS ..... 9</b>
2.1	SAR Measurement System ..... 10
2.2	1900MHz DECT Head SAR Test Results and Course Area Scans – 2D ..... 16
<b>3</b>	<b>TEST EQUIPMENT USED ..... 20</b>
3.1	Test Equipment Used ..... 21
3.2	Test Software ..... 22
3.3	Dielectric Properties of Simulant Liquids ..... 23
3.4	Test Conditions ..... 24
3.5	Measurement Uncertainty ..... 25
<b>4</b>	<b>PHOTOGRAPHS ..... 26</b>
4.1	Test Positional Photographs ..... 27
4.2	Photographs of Equipment Under Test (EUT) ..... 29
<b>5</b>	<b>DISCLAIMERS AND COPYRIGHT ..... 32</b>
5.1	Disclaimers and Copyright ..... 33
<b>ANNEX A</b>	<b>Probe Calibration Information ..... A.2</b>



Product Service

## **SECTION 1**

### **REPORT SUMMARY**

Specific Absorption Rate Testing of the GN Netcom  
DECT 1900MHz Jabra PRO 9400 series Headset  
In accordance with OET 65



Product Service

## 1.1 INTRODUCTION

The information contained in this report is intended to show verification of the Specific Absorption Rate Testing of the GN Netcom DECT 1900MHz Jabra PRO 9400 series Headset to the requirements of the OET 65 (C), Evaluating Compliance with FCC Guidelines for Human Exposure to Radiofrequency Electromagnetic Fields

Objective	To perform Specific Absorption Rate Testing to determine the Equipment Under Test's (EUT's) compliance with the specification, for the series of tests carried out.
Applicant	GN Netcom
Manufacturer	GN Netcom
Manufacturing Description	DECT 1900MHz Jabra PRO 9400 series Headset
Model Number	DECT 1900MHz Jabra PRO 9400 series Headset
Power Class	R&TTE: Class 1
Hardware Version	28-02865
Software Version	1.26
Battery Cell Manufacturer	Synergy
Model Number	AHB412434PJ
Test Specification/Issue/Date	OET 65 (C) - 2001
Start of Test	16 April 2009
Finish of Test	21 April 2009
Related Document(s)	RSS-102



## 1.2 BRIEF SUMMARY OF RESULTS

The wireless portable device described within this report has been shown to be capable of compliance for localised specific absorption rate (SAR) for OET 65(C) – 2001 of 1.0 W/kg.

The measurements shown in this report were made in accordance with the procedures specified OET 65(C) – 2001 and RSS-102.

All reported testing was carried out on a sample of equipment to demonstrate compliance with EN 62209-1: 2006. The sample tested was found to comply with the requirements in the applied rules.

The maximum 10g volume averaged SAR found during this Assessment

Max 1g SAR (W/kg)	0.020
The maximum 1g volume averaged SAR level measured for all the tests performed did not exceed the limits for General Population/Uncontrolled Exposure (W/kg) Partial Body of 1.6 W/kg. Level defined in Supplement C (Edition 01-01) to OET Bulletin 65 (97-01).	

## 1.3 TEST RESULTS SUMMARY

### 1.3.1 System Performance / Validation Check Results

Prior to formal testing being performed a System Check was performed in accordance with OET 65(C) – 2001 and the results were compared against published data in Standard IEEE 1528-2003. The following results were obtained: -

System performance / Validation results

Date	Dipole Used	Frequency (MHz)	Max 1g SAR (W/kg)	Percentage Drift on Reference	Max 10g SAR (W/kg)	Percentage Drift on Reference
01/03/2009	1883.60	1814.00	37.222*	-2.30%	19.638*	-0.82%

\*Normalised to a forward power of 1W



**1.3.2 Results Summary Tables**

**1.3.3 Results Summary Tables**

DECT 1900MHz HEAD Specific Absorption Rate (Maximum SAR) 1g & 10g Results for the DECT 1900MHz Headset Device 1 in standard configuration with standard antenna & battery.

Position		Channel Number	Frequency (MHz)	Max Spot SAR (W/kg)	Max 1g SAR (W/kg)	Max 10g SAR (W/kg)	SAR Drift (%)	Area scan (Figure number)
Left or Right Hand Ear	Mobile Position							
Left	Cheek	2	1925.01	0.020	0.013	0.010	0.000	Figure 8
Right	Cheek	2	1925.01	0.030	0.017	0.011	3.220	Figure 9
Limit for General Population (Uncontrolled Exposure) 1.6 W/kg (1g) & 2.0 W/kg (10g)								

DECT 1900MHz HEAD Specific Absorption Rate (Maximum SAR) 1g & 10g Results for the DECT 1900MHz Headset Device 2 in worst case configuration as determined by the testing of Device 1 with standard antenna & battery.

Position		Channel Number	Frequency (MHz)	Max Spot SAR (W/kg)	Max 1g SAR (W/kg)	Max 10g SAR (W/kg)	SAR Drift (%)	Area scan (Figure number)
Left or Right Hand Ear	Mobile Position							
Right	Cheek	2	1925.01	0.020	0.017	0.011	3.310	Figure 10
Limit for General Population (Uncontrolled Exposure) 1.6 W/kg (1g) & 2.0 W/kg (10g)								

DECT 1900MHz HEAD Specific Absorption Rate (Maximum SAR) 1g & 10g Results for the DECT 1900MHz Headset Device 3 in worst case configuration as determined by the testing of Device 1 with standard antenna & battery.

Position		Channel Number	Frequency (MHz)	Max Spot SAR (W/kg)	Max 1g SAR (W/kg)	Max 10g SAR (W/kg)	SAR Drift (%)	Area scan (Figure number)
Left or Right Hand Ear	Mobile Position							
Right	Cheek	2	1925.01	0.030	0.020	0.011	3.920	Figure 11
Limit for General Population (Uncontrolled Exposure) 1.6 W/kg (1g) & 2.0 W/kg (10g)								



Product Service

## **1.4 PRODUCT INFORMATION**

### **1.4.1 Technical Description**

The equipment under test (EUT) was a DECT 1900MHz Headset. A full technical description can be found in the manufacturer's documentation.

### **1.4.2 Test Configuration and Modes of Operation**

The DECT 1900MHz Headset is a DECT single band Headset. The testing was performed with batteries supplied by Trac-KTL and manufactured by Synergy. Each battery was fully charged before each measurement and there were no external connections.

For head SAR assessment, testing was performed with the device in the declared normal position of operation for the 1900MHz DECT frequency band at maximum power. The device was placed against a Specific Anthropomorphic Mannequin (SAM) phantom as specified in the OET 65(C) – 2001. The phantom was filled with simulant liquid appropriate to the frequency band. The dielectric properties were measured and found to be in accordance with the requirements for the dielectric properties specified OET 65(C) – 2001 testing was performed at both the left and right ear of the phantom at both handset positions stated in the applied specification.

Testing was performed using three devices (headset attachments) on the first device at the middle frequency of the band at the left and right cheek for the position giving maximum SAR. The position giving the maximum SAR was then used to measure the second and third devices. This was achieved using the customers support equipment.

The DECT 1900MHz Headset device had an integral antenna so that the requirement for testing with antenna extended and retracted was not applicable.

Included in this report are descriptions of the test method; the equipment used and an analysis of the test uncertainties applicable and diagrams indicating the locations of maximum SAR for each test position, as appropriate.





**1.5 FCC POWER MEASUREMENTS**

**1.5.1 Method**

Conducted power measurements were made using a power meter. Radiated power was calculated from the radiated field strength measurements and the known antenna gain.

**1.5.2 Conducted / Radiated Power Measurements**

Radiated

TRAC Sample No.	TUV Sample No.	Channel		Frequency (MHz)	Polarity	EIRP (dBm)
S04	(75906064-TSR0011)	FCC	4	1921.233	H	19.619
S04		FCC	4	1921.200	V	18.209
S04		FCC	2	1924.650	H	20.699
S04		FCC	2	1924.377	V	17.909
S04		FCC	0	1928.133	H	18.383
S04		FCC	0	1928.422	V	17.213

Conducted

TUV Sample No.	Channel		Conducted Carrier Power (dBm)
(75906064-TSR0011)	FCC	4	18.69
		2	18.89
		0	19.42



Product Service

## **SECTION 2**

### **TEST DETAILS**

Specific Absorption Rate Testing of the GN Netcom  
DECT 1900MHz Jabra PRO 9400 series Headset  
In accordance with OET 65

## 2.1 SAR MEASUREMENT SYSTEM

### 2.1.1 Robot System Specification

The SAR measurement system being used is the IndexSAR SARA2 system, which consists of a Mitsubishi RV-E2 6-axis robot arm and controller, IndexSAR probe and amplifier and SAM phantom Head Shape. The robot is used to articulate the probe to programmed positions inside the phantom head to obtain the SAR readings from the DUT.

Schematic diagram of the SAR measurement system

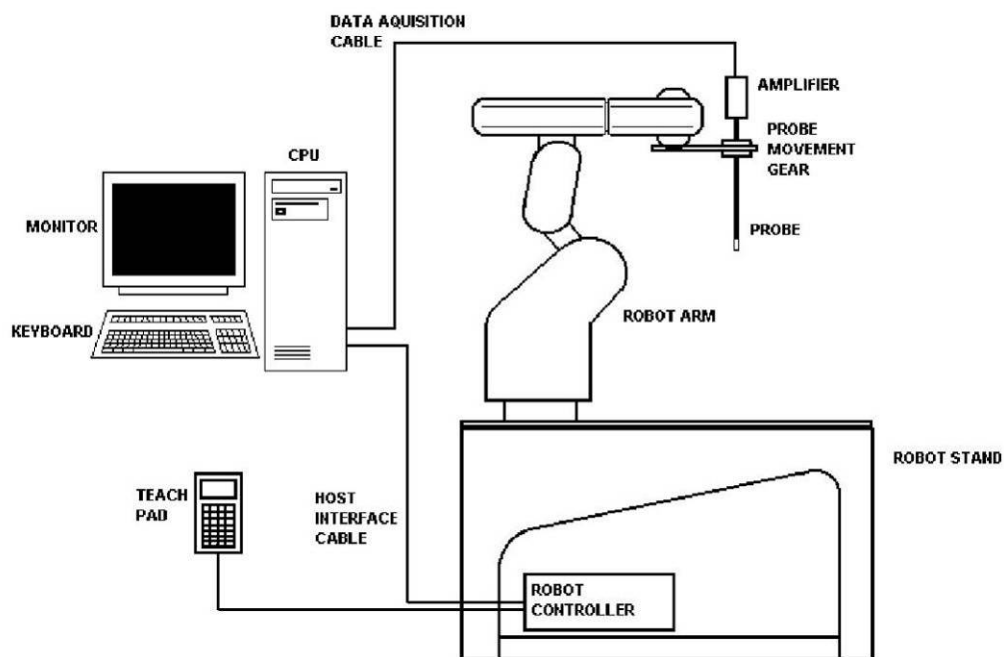

Figure 1

The system is controlled remotely from a PC, which contains the software to control the robot and data acquisition equipment. The software also displays the data obtained from test scans.

The position and digitised shape of the phantom heads are made available to the software for accurate positioning of the probe and reduction of set-up time.

The SAM phantom heads are individually digitised using a Mitutoyo CMM machine to a precision of 0.001mm. The data is then converted into a shape format for the software, providing an accurate description of the phantom shell.

In operation, the system first does an area (2D) scan at a fixed depth within the liquid from the inside wall of the phantom. When the maximum SAR point has been found, the system will then carry out a 3D scan centred at that point to determine volume averaged SAR level.

## 2.1.2 Probe and Amplifier Specification

### IXP-050 IndexSAR isotropic immersible SAR probe

The probes are constructed using three orthogonal dipole sensors arranged on an interlocking, triangular prism core. The probes have built-in shielding against static charges and are contained within a PEEK cylindrical enclosure material at the tip. Probe calibration is described in the following section.

### IFA-010 Fast Amplifier

Technical description of IndexSAR IFA-010 Fast probe amplifier  
A block diagram of the fast probe amplifier electronics is shown below.

### Block diagram of the fast probe amplifier electronic

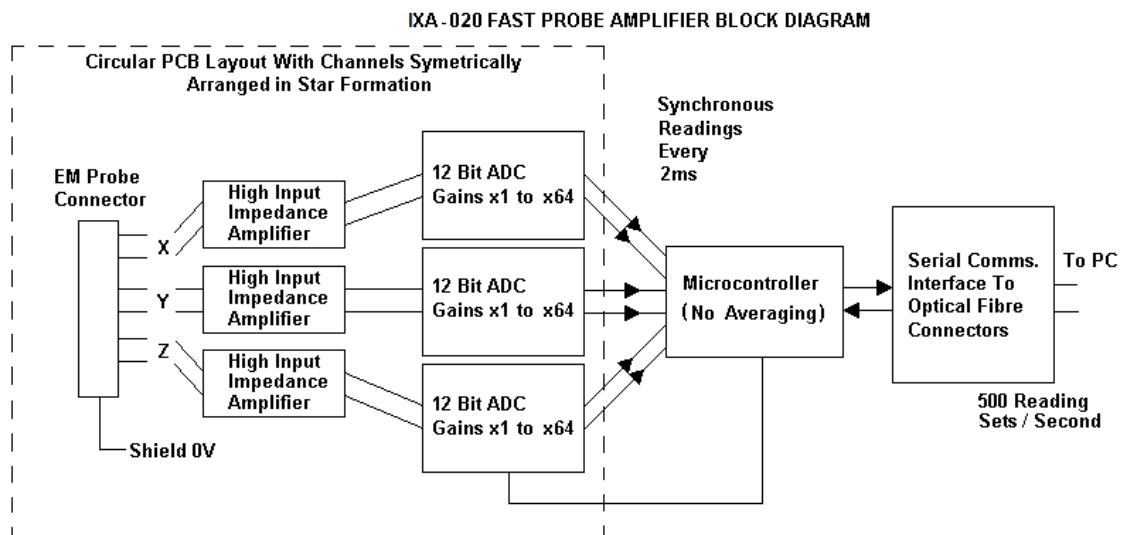

Figure 2

This amplifier has a time constant of approx.  $50\mu\text{s}$ , which is much faster than the SAR probe response time. The overall system time constant is therefore that of the probe ( $<1\text{ms}$ ) and reading sets for all three channels (simultaneously) are returned every 2ms to the PC. The conversion period is approx.  $1\mu\text{s}$  at the start of each 2ms period. This enables the probe to follow pulse modulated signals of periods  $\gg 2\text{ms}$ . The PC software applies the linearisation procedure separately to each reading, so no linearisation corrections for the averaging of modulated signals are needed in this case. It is important to ensure that the probe reading frequency and the pulse period are not synchronised and the behaviour with pulses of short duration in comparison with the measurement interval need additional consideration.

### Phantoms

The Flat phantom used is a rectangular Perspex Box IndexSAR item IXB-070. Dimensions 210w 210d 210h (mm). This phantom is used with IndexSAR side bench IXM-030.

The Specific Anthropomorphic Mannequin (SAM) Upright Phantom is fabricated using moulds generated from the CAD files as specified by CENELEC EN 62209-1: 2006. It is mounted via a rotation base to a supporting table, which also holds the robotic positioner. The phantom and robot alignment is assured by both mechanical and laser registration systems.

### 2.1.3 SAR Measurement Procedure

Principal components of the SAR measurement test bench

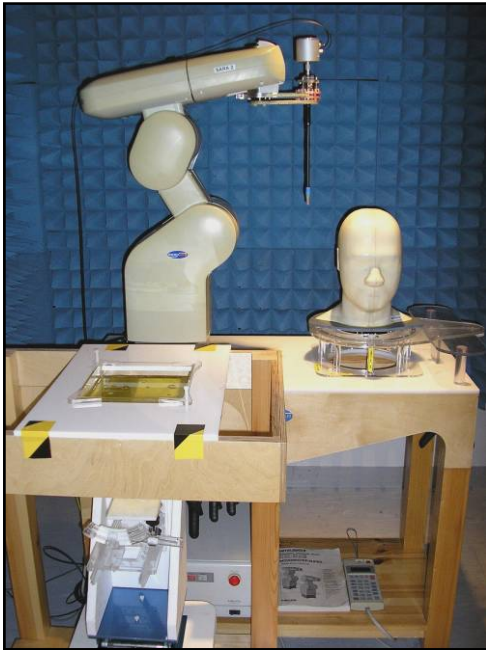

Figure 3

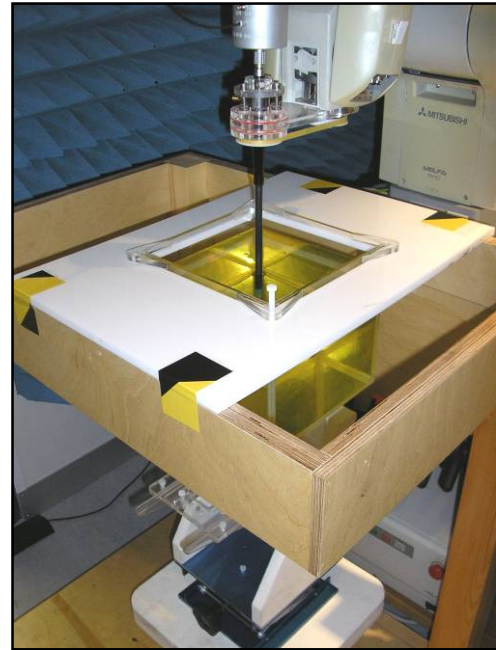

Figure 4

The major components of the test bench are shown in the pictures above. A test set and dipole antenna control the handset via an air link and a low-mass phone holder can position the phone at either ear. Graduated scales are provided to set the phone in the 15 degree position. The upright phantom head holds approx. 7 litres of simulant liquid. The phantom is filled and emptied through a 45mm diameter penetration hole in the top of the head.

After an area scan has been done at a fixed distance of 8mm from the surface of the phantom on the source side, a 3D scan is set up around the location of the maximum spot SAR. First, a point within the scan area is visited by the probe and a SAR reading taken at the start of testing. At the end of testing, the probe is returned to the same point and a second reading is taken. Comparison between these start and end readings enables the power drift during measurement to be assessed.

#### SARA2 Interpolation and Extrapolation schemes

SARA2 software contains support for both 2D cubic B-spline interpolation as well as 3D cubic B-spline interpolation. In addition, for extrapolation purposes, a general  $n^{\text{th}}$  order polynomial fitting routine is implemented following a singular value decomposition algorithm presented in [4]. A 4<sup>th</sup> order polynomial fit is used by default for data extrapolation, but a linear-logarithmic fitting function can be selected as an option. The polynomial fitting procedures have been tested by comparing the fitting coefficients generated by the SARA2 procedures with those obtained using the polynomial fit functions of Microsoft Excel when applied to the same test input data.



### Interpolation of 2D area scan

The 2D cubic B-spline interpolation is used after the initial area scan at fixed distance from the phantom shell wall. The initial scan data are collected with approx. 115mm spatial resolution and spline interpolation is used to find the location of the local maximum to within a 1mm resolution for positioning the subsequent 3D scanning.

### Extrapolation of 3D scan

For the 3D scan, data are collected on a spatially regular 3D grid having (by default) 6.4 mm steps in the lateral dimensions and 3.5 mm steps in the depth direction (away from the source). SARA2 enables full control over the selection of alternative step sizes in all directions.

The digitised shape of the head is available to the SARA2 software, which decides which points in the 3D array are sufficiently well within the shell wall to be 'visited' by the SAR probe. After the data collection, the data are extrapolated in the depth direction to assign values to points in the 3D array closer to the shell wall. A notional extrapolation value is also assigned to the first point outside the shell wall so that subsequent interpolation schemes will be applicable right up to the shell wall boundary.

### Interpolation of 3D scan and volume averaging

The procedure used for defining the shape of the volumes used for SAR averaging in the SARA2 software follow the method of adapting the surface of the 'cube' to conform with the curved inner surface of the phantom (see Appendix C.2.2.1 in EN 62209-1: 2006). This is called, here, the conformal scheme.

For each row of data in the depth direction, the data are extrapolated and interpolated to less than 1mm spacing and average values are calculated from the phantom surface for the row of data over distances corresponding to the requisite depth for 10g and 1g cubes. This results in two 2D arrays of data, which are then cubic B-spline interpolated to sub mm lateral resolution. A search routine then moves an averaging square around through the 2D array and records the maximum value of the corresponding 1g and 10g volume averages. For the definition of the surface in this procedure, the digitised position of the headshell surface is used for measurement in head-shaped phantoms. For measurements in rectangular, box phantoms, the distance between the phantom wall and the closest set of gridded data points is entered into the software.

For measurements in box-shaped phantoms, this distance is under the control of the user. The effective distance must be greater than 2.5mm as this is the tip-sensor distance and to avoid interface proximity effects, it should be at least 5mm. A value of 6 or 8mm is recommended. This distance is called **dbe** in EN 62209-1: 2006.

For automated measurements inside the head, the distance cannot be less than 2.5mm, which is the radius of the probe tip and to avoid interface proximity effects, a minimum clearance distance of  $x$  mm is retained. The actual value of **dbe** will vary from point to point depending upon how the spatially-regular 3D grid points fit within the shell. The greatest separation is when a grid point is just not visited due to the probe tip dimensions. In this case the distance could be as large as the step-size plus the minimum clearance distance (i.e with  $x=5$  and a step size of 3.5, **dbe** will be between 3.5 and 8.5mm).

The default step size (**dstep** in EN 62209-1: 2006) used is 3.5mm, but this is under user-control. The compromise is with time of scan, so it is not practical to make it much smaller or scan times become long and power-drop influences become larger.



Product Service

The robot positioning system specification for the repeatability of the positioning (**dss** in EN 62209-1: 2006) is +/- 0.04mm.

The phantom shell is made by an industrial moulding process from the CAD files of the SAM shape, with both internal and external moulds. For the upright phantoms, the external shape is subsequently digitised on a Mitutoyo CMM machine (Euro C574) to a precision of 0.001mm. Wall thickness measurements made non-destructively with an ultrasonic sensor indicate that the shell thickness (**dph**) away from the ear is 2.0 +/- 0.1mm. The ultrasonic measurements were calibrated using additional mechanical measurements on available cut surfaces of the phantom shells.

For the upright phantom, the alignment is based upon registration of the rotation axis of the phantom on its 253mm-diameter baseplate bearing and the position of the probe axis when commanded to go to the axial position. A laser alignment tool is provided (procedure detailed elsewhere). This enables the registration of the phantom tip (**dmis**) to be assured to within approx. 0.2mm. This alignment is done with reference to the actual probe tip after installation and probe alignment. The rotational positioning of the phantom is variable – offering advantages for special studies, but locating pins ensure accurate repositioning at the principal positions (LH and RH ears).

## 2.1.4 Head Test Positions

This recommended practice specifies exactly two test positions for the handset against the head phantom, the “Cheek” position and the “tilted” position. These two test positions are defined in the following sub-clauses. The handset should be tested in both positions on the left and right sides of the SAM phantom. In each test position the centre of the earpiece of the device is placed directly at the entrance of the auditory canal. The angles mentioned in the test positions used are referenced to the line connecting both auditory canal openings. The plane this line is on is known as the reference plane. Testing is performed on the right and left-hand sides of the generic phantom head.

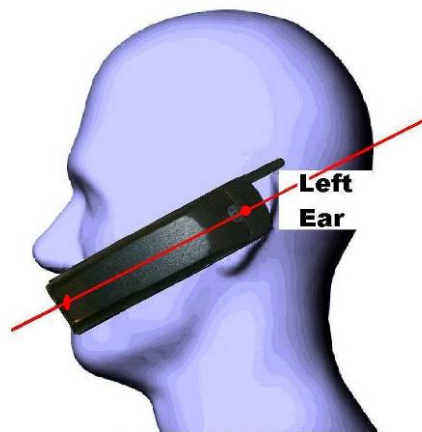

Figure 5. – Side View of Mobile next to head showing alignment.

### The Cheek Position

The Cheek Position is where the mobile is in the reference plane and the line between the mobile and the line connecting both auditory canal openings is reduced until any part of the mobile touches any part of the generic twin phantom head.

### The 15° Position

The 15° Position is where the mobile is in the reference Cheek position and the phone is kept in contact with the auditory canal at the earpiece; the bottom of the phone is then tilted away from the phantom mouth by 15°.

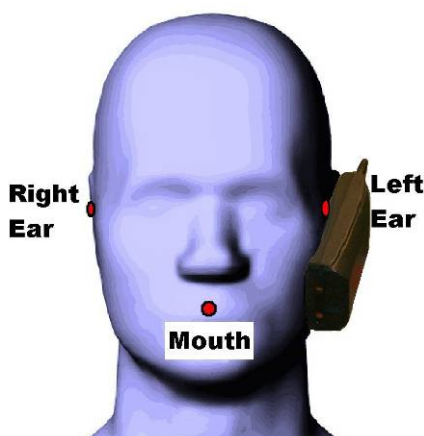

Figure 6. – Cheek Position.

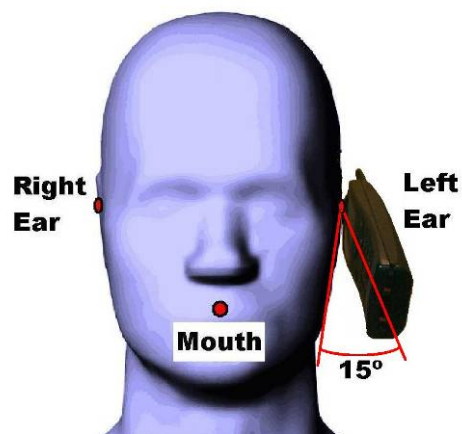

Figure 7. – 15° Tilt Position.



2.2 1900MHz DECT HEAD SAR TEST RESULTS AND COURSE AREA SCANS – 2D

SYSTEM / SOFTWARE:	SARA2 / 2.53 VPM	INPUT POWER DRIFT:	0.0 dB
DATE / TIME:	20/04/2009 14:49:57	DUT BATTERY MODEL/NO:	AHB412434PJ
FILENAME:	75906064-251000-07.txt	PROBE SERIAL NUMBER:	0170
AMBIENT TEMPERATURE:	22.40°C	LIQUID SIMULANT:	1900Head
DEVICE UNDER TEST:	DECT Headset	RELATIVE PERMITTIVITY:	39.57
RELATIVE HUMIDITY:	38.20%	CONDUCTIVITY:	1.471
PHANTOM S/NO:	Head_04_35.csv	LIQUID TEMPERATURE:	22.20°C
PHANTOM ROTATION:	0°	MAX SAR Y-AXIS LOCATION:	8.00mm
DUT POSITION:	Left-Cheek	MAX SAR Z-AXIS LOCATION:	-134.45mm
ANTENNA CONFIGURATION:	N/A	MAX E FIELD:	3.19 V/m
TEST FREQUENCY:	1925.0MHz	SAR 1g:	0.013 W/kg
AIR FACTORS:	423.9 / 376.7 / 399.3	SAR 10G:	0.010 W/kg
CONVERSION FACTORS:	0.337 / 0.337 / 0.337	SAR START:	0.003 W/kg
TYPE OF MODULATION:	GFSK	SAR END:	0.003 W/kg
MODN. DUTY CYCLE:	100%	SAR DRIFT DURING SCAN:	0.000 %
DIODE COMPRESSION FACTORS (V*200):	20 / 20 / 20	PROBE BATTERY LAST CHANGED:	20/04/2009
INPUT POWER LEVEL:	20.7dBm	EXTRAPOLATION:	poly4

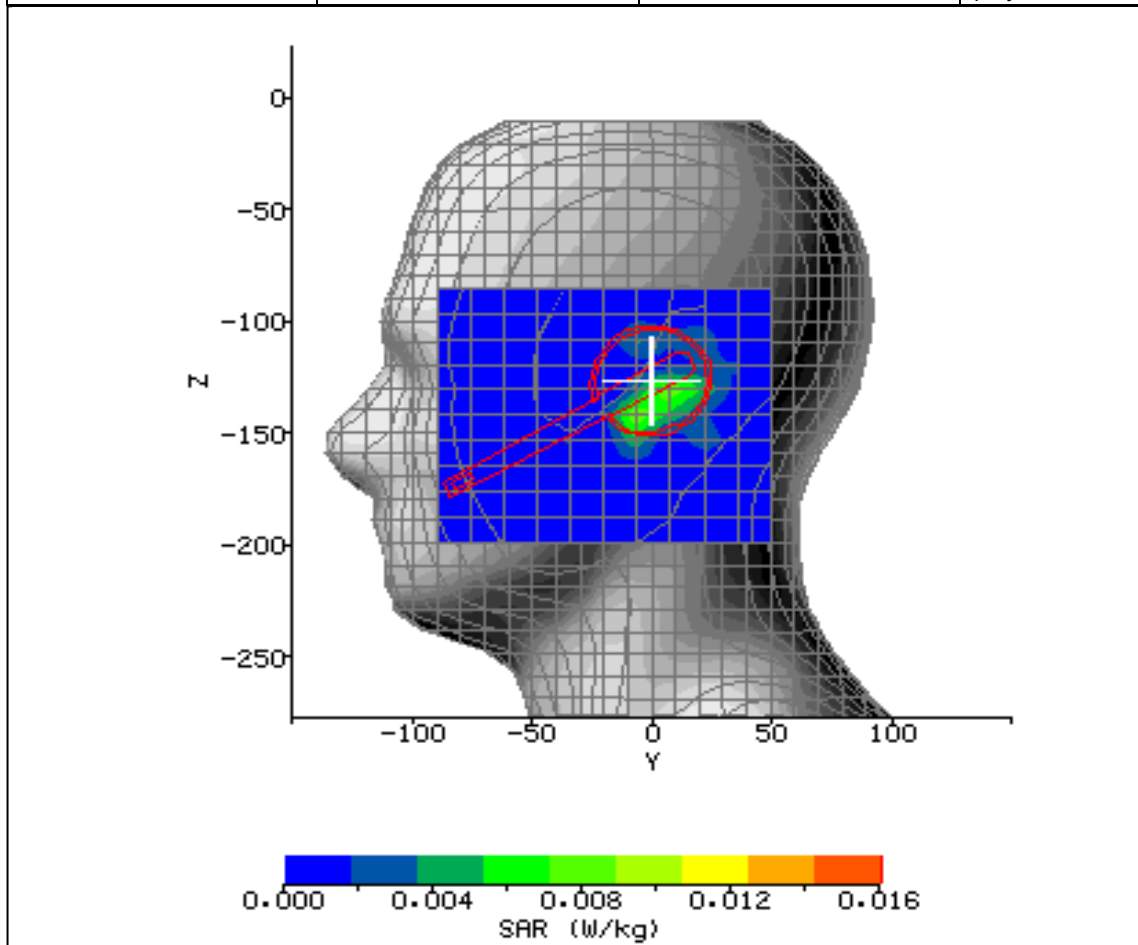

Figure 8: SAR Head Testing Results for the DECT Headset Mobile Device 1 in Left-Cheek Position; Tested at 1925.0MHz (Channel 2).

SYSTEM / SOFTWARE:	SARA2 / 2.53 VPM	INPUT POWER DRIFT:	0.0 dB
DATE / TIME:	20/04/2009 15:18:56	DUT BATTERY MODEL/NO:	AHB412434PJ
FILENAME:	75906064-251000-08.txt	PROBE SERIAL NUMBER:	0170
AMBIENT TEMPERATURE:	22.30°C	LIQUID SIMULANT:	1900Head
DEVICE UNDER TEST:	DECT Headset	RELATIVE PERMITTIVITY:	39.57
RELATIVE HUMIDITY:	36.60%	CONDUCTIVITY:	1.471
PHANTOM S/NO:	Head_04_35.csv	LIQUID TEMPERATURE:	22.20°C
PHANTOM ROTATION:	180°	MAX SAR Y-AXIS LOCATION:	-8.00mm
DUT POSITION:	Right-Cheek	MAX SAR Z-AXIS LOCATION:	-109.15mm
ANTENNA CONFIGURATION:	N/A	MAX E FIELD:	4.70 V/m
TEST FREQUENCY:	1925.0MHz	SAR 1g:	0.017 W/kg
AIR FACTORS:	423.9 / 376.7 / 399.3	SAR 10G:	0.011 W/kg
CONVERSION FACTORS:	0.337 / 0.337 / 0.337	SAR START:	0.004 W/kg
TYPE OF MODULATION:	GFSK	SAR END:	0.004 W/kg
MODN. DUTY CYCLE:	100%	SAR DRIFT DURING SCAN:	3.220 %
DIODE COMPRESSION FACTORS (V*200):	20 / 20 / 20	PROBE BATTERY LAST CHANGED:	20/04/2009
INPUT POWER LEVEL:	20.7dBm	EXTRAPOLATION:	poly4

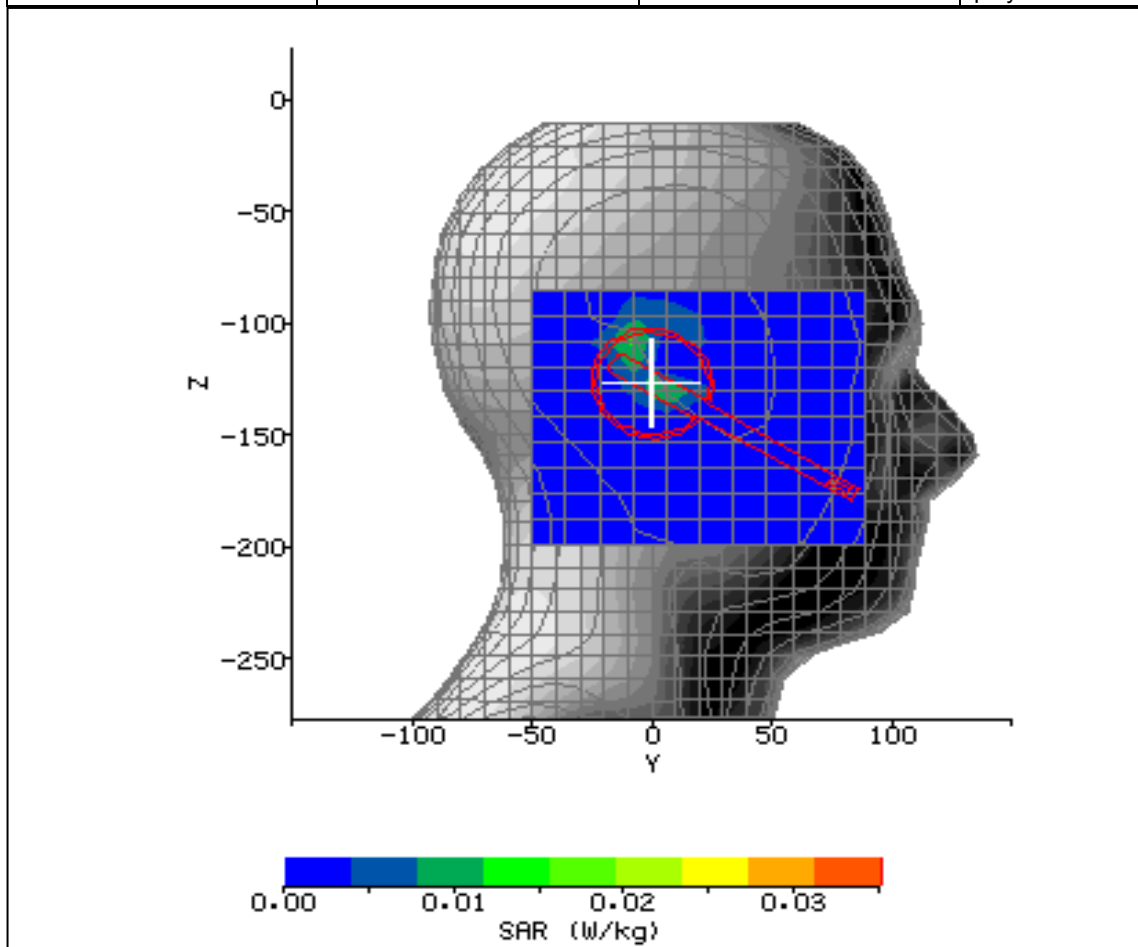

Figure 9: SAR Head Testing Results for the DECT Headset Mobile Device 1 in Right-Cheek Position; Tested at 1925.0MHz (Channel 2).

SYSTEM / SOFTWARE:	SARA2 / 2.53 VPM	INPUT POWER DRIFT:	0.0 dB
DATE / TIME:	20/04/2009 16:21:55	DUT BATTERY MODEL/NO:	AHB412434PJ
FILENAME:	75906064-251000-09.txt	PROBE SERIAL NUMBER:	0170
AMBIENT TEMPERATURE:	22.40°C	LIQUID SIMULANT:	1900Head
DEVICE UNDER TEST:	DECT Headset	RELATIVE PERMITTIVITY:	39.57
RELATIVE HUMIDITY:	31.80%	CONDUCTIVITY:	1.471
PHANTOM S/NO:	Head_04_35.csv	LIQUID TEMPERATURE:	22.20°C
PHANTOM ROTATION:	180°	MAX SAR Y-AXIS LOCATION:	3.20mm
DUT POSITION:	Right-Cheek	MAX SAR Z-AXIS LOCATION:	-117.20mm
ANTENNA CONFIGURATION:	N/A	MAX E FIELD:	4.06 V/m
TEST FREQUENCY:	1925.0MHz	SAR 1g:	0.017 W/kg
AIR FACTORS:	423.9 / 376.7 / 399.3	SAR 10G:	0.011 W/kg
CONVERSION FACTORS:	0.337 / 0.337 / 0.337	SAR START:	0.005 W/kg
TYPE OF MODULATION:	GFSK	SAR END:	0.005 W/kg
MODN. DUTY CYCLE:	100%	SAR DRIFT DURING SCAN:	3.310 %
DIODE COMPRESSION FACTORS (V*200):	20 / 20 / 20	PROBE BATTERY LAST CHANGED:	20/04/2009
INPUT POWER LEVEL:	20.7dBm	EXTRAPOLATION:	poly4

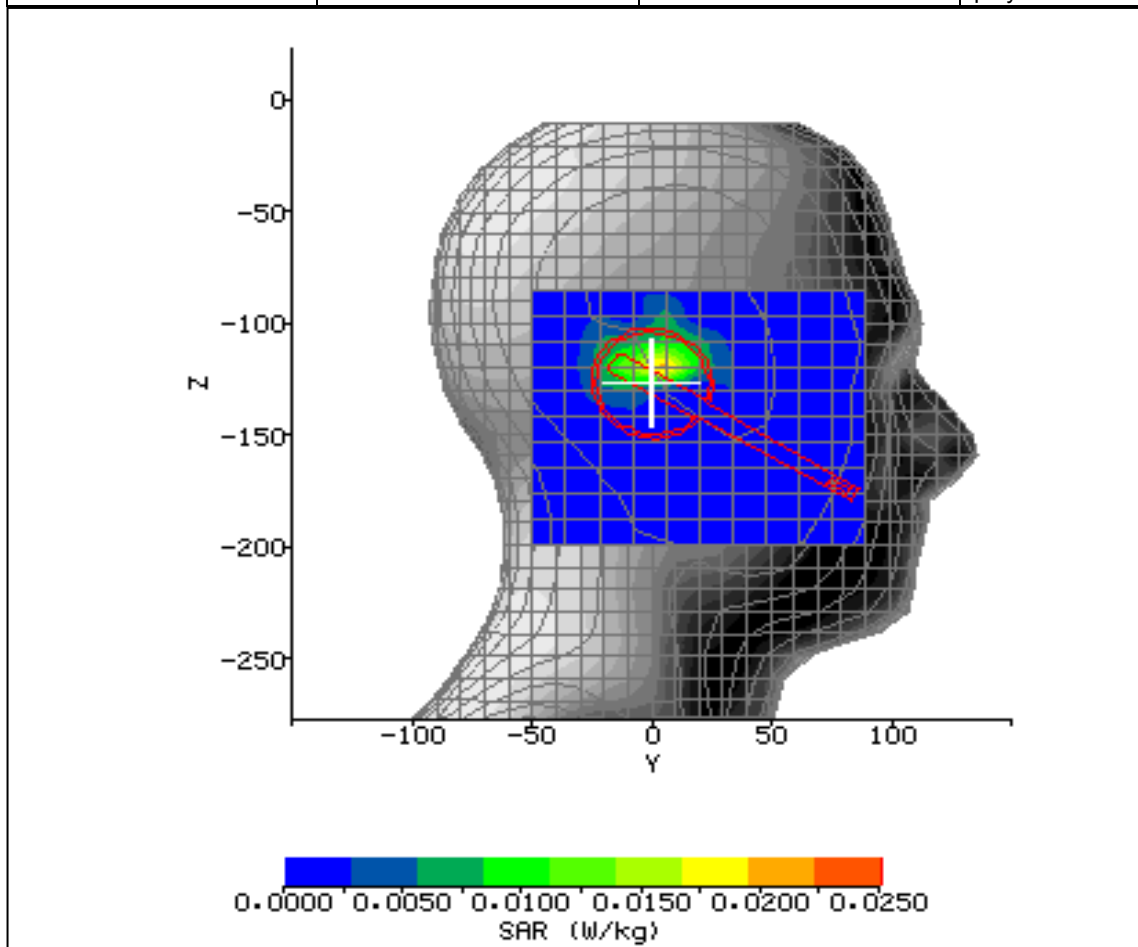

Figure 10: SAR Head Testing Results for the DECT Headset Mobile Device 2 in Right-Cheek Position; Tested at 1925.0MHz (Channel 2).

SYSTEM / SOFTWARE:	SARA2 / 2.53 VPM	INPUT POWER DRIFT:	0.0 dB
DATE / TIME:	21/04/2009 08:54:40	DUT BATTERY MODEL/NO:	AHB412434PJ
FILENAME:	75906064-251000-10.txt	PROBE SERIAL NUMBER:	0170
AMBIENT TEMPERATURE:	22.40°C	LIQUID SIMULANT:	1900Head
DEVICE UNDER TEST:	DECT Headset	RELATIVE PERMITTIVITY:	39.57
RELATIVE HUMIDITY:	33.90%	CONDUCTIVITY:	1.471
PHANTOM S/NO:	Head_04_35.csv	LIQUID TEMPERATURE:	22.20°C
PHANTOM ROTATION:	180°	MAX SAR Y-AXIS LOCATION:	13.00mm
DUT POSITION:	Right-Cheek	MAX SAR Z-AXIS LOCATION:	-126.40mm
ANTENNA CONFIGURATION:	N/A	MAX E FIELD:	4.40 V/m
TEST FREQUENCY:	1925.0MHz	SAR 1g:	0.020 W/kg
AIR FACTORS:	423.9 / 376.7 / 399.3	SAR 10G:	0.011 W/kg
CONVERSION FACTORS:	0.337 / 0.337 / 0.337	SAR START:	0.002 W/kg
TYPE OF MODULATION:	GFSK	SAR END:	0.002 W/kg
MODN. DUTY CYCLE:	100%	SAR DRIFT DURING SCAN:	3.920 %
DIODE COMPRESSION FACTORS (V*200):	20 / 20 / 20	PROBE BATTERY LAST CHANGED:	21/04/2009
INPUT POWER LEVEL:	20.7dBm	EXTRAPOLATION:	poly4

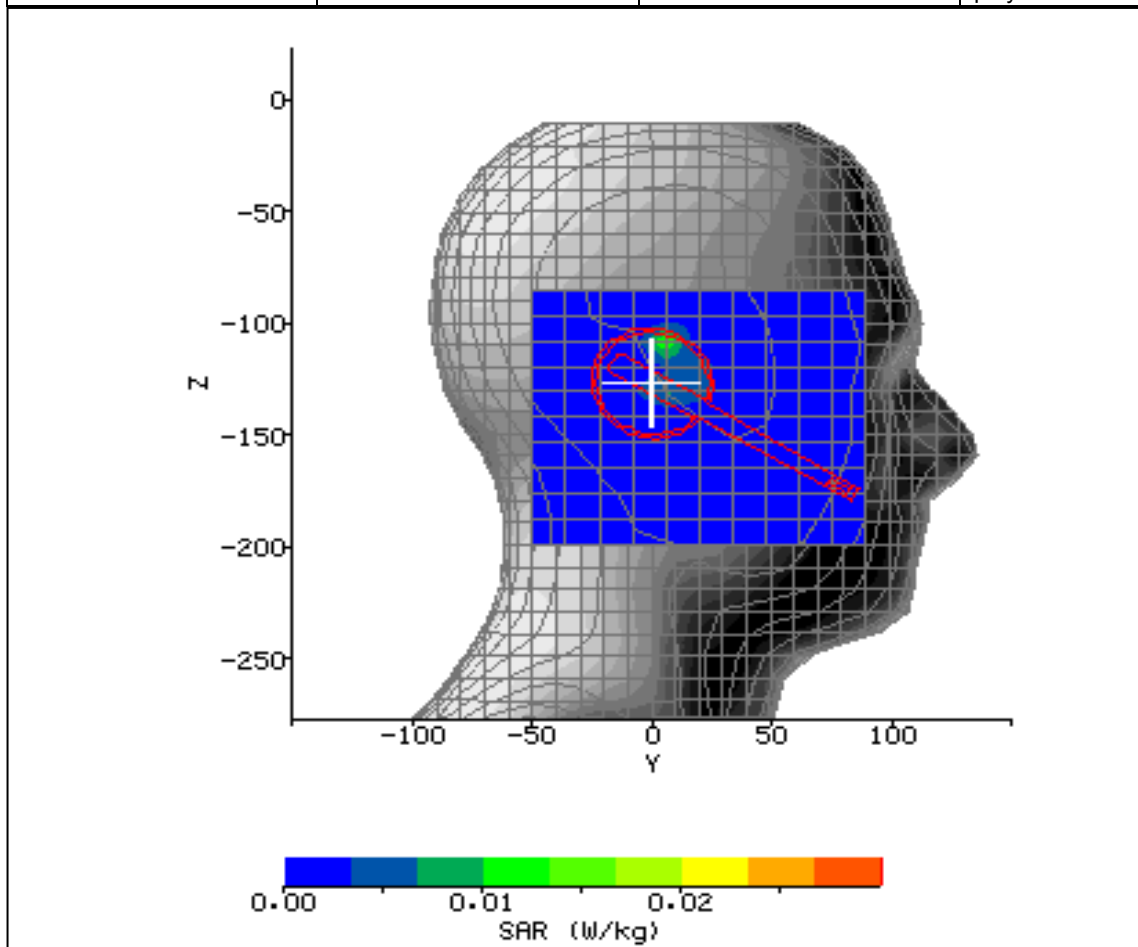

Figure 11: SAR Head Testing Results for the DECT Headset Mobile Device 3 in Right-Cheek Position; Tested at 1925.0MHz (Channel 2).



Product Service

### **SECTION 3**

#### **TEST EQUIPMENT USED**



### 3.1 TEST EQUIPMENT USED

The following test equipment was used at TUV Product Service Ltd:

Instrument Description	Manufacturer	Model Type	TE Number	Cal Period (months)	Calibration Due Date
Spectrum Analyser	Rohde & Schwarz	FSB	54	-	TU
Spectrum Analyser	Rohde & Schwarz	FSB	55	-	TU
Directional Coupler	Krytar	1850	58	-	TU
Power Sensor	Rohde & Schwarz	NRV-Z1	60	12	24-Nov-2009
Industrial Robot	Mitsubishi	RV-E2/CR-E116	63	-	TU
Thermometer	Digitron	T208	64	12	24-Nov-2009
Thermocouple (Type K)	TUV	TYPE K	65	12	24-Nov-2009
Attenuator (20dB, 20W)	Narda	766F-20	483	12	3-Jun-2009
Immersible SAR Probe	IndexSar Ltd	IXP-050	1555	12	1-Oct-2009
Amplifier (20KHz-50MHz, 50W)	Amp Research	50A15	726	6	TU
Fast Probe Amplifier (3 channels)	IndexSar Ltd	IFA-010	1558	0	TU
SAM Head Phantom	Antennessa	Head_04_35.csv	1561	-	TU
Validation Amplifier (10MHz - 2.5GHz)	IndexSar Ltd	VBM2500-3	2415	-	TU
Hygromer	Rotronic	I-1000	2784	12	29-Sep-2009
Power Sensor	Rohde & Schwarz	NRV- Z5	2878	12	2-Jun-2009
Dual Channel Power Meter	Rohde & Schwarz	NRVD	3259	12	25-Nov-2009
900MHz Head Tissue Simulant	TUV Product Service Ltd	Batch 12	N/A	1	30-Apr-2009
1900MHz Head Tissue Simulant	TUV Product Service Ltd	Batch 04	N/A	1	30-Apr-2009

TU – Traceability Unscheduled



Product Service

### 3.2 TEST SOFTWARE

The following software was used to control the TÜV Product Service SARA2 System.

Instrument	Version Number	Date
SARA2 system	v.2.5.3 VPM	28/11/2006
Mitsubishi robot controller firmware revision	RV-E2 Version C9a	-
IFA-10 Probe amplifier	Version 2	-



### 3.3 DIELECTRIC PROPERTIES OF SIMULANT LIQUIDS

The fluid properties of the simulant fluids used during routine SAR evaluation meet the dielectric properties required by EN 62209-1: 2006 & OET Bulletin 65 (Edition 97-01).

The fluids were calibrated in our Laboratory and re-checked prior to any measurements being made against reference fluids stated in IEEE 1528-2003 of 0.9% NaCl (Salt Solution) at 23°C and also for Dimethylsulphoxide (DMS) at 21°C.

The fluids were made at TÜV Product Service Ltd under controlled conditions from the following OET(65)c formulae and IEEE 1528-2003. The composition of ingredients may have been modified accordingly to achieve the desired target tissue parameters required for routine SAR evaluation:

#### OET 65(c) Recipes

Ingredients (% by weight)	Frequency (MHz)									
	450		835		915		1900		2450	
Tissue Type	Head	Body	Head	Body	Head	Body	Head	Body	Head	Body
Water	38.56	51.16	41.45	52.4	41.05	56.0	54.9	40.4	62.7	73.2
Salt (NaCl)	3.95	1.49	1.45	1.4	1.35	0.76	0.18	0.5	0.5	0.04
Sugar	56.32	46.78	56.0	45.0	56.5	41.76	0.0	58.0	0.0	0.0
HEC	0.98	0.52	1.0	1.0	1.0	1.21	0.0	1.0	0.0	0.0
Bactericide	0.19	0.05	0.1	0.1	0.1	0.27	0.0	0.1	0.0	0.0
Triton X-100	0.0	0.0	0.0	0.0	0.0	0.0	0.0	0.0	36.8	0.0
DGBE	0.0	0.0	0.0	0.0	0.0	0.0	44.92	0.0	0.0	26.7
Dielectric Constant	43.42	58.0	42.54	56.1	42.0	56.8	39.9	54.0	39.8	52.5
Conductivity (S/m)	0.85	0.83	0.91	0.95	1.0	1.07	1.42	1.45	1.88	1.78

#### IEEE 1528 Recipes

Frequency (MHz)	300	450		835			900			1450	1800			1900		1950	2000	2100		2450			3000
Recipe#	1	1	3	1			1	2	3	1	1	2	2	3	1	2	4	1	1	2	2	3	2
Ingredients (% by weight)																							
1, 2-Propanediol						64.81																	
Bactericide	0.19	0.19	0.50	0.10	0.10		0.50																0.50
Diacetin			48.90				49.20																49.45
DGBE								45.41	47.00	13.84	44.92			44.94	13.84	45.00	50.00	50.00	7.99	7.99			7.99
HEC	0.98	0.96		1.00	1.00																		
NaCl	5.95	3.95	1.70	1.45	1.48	0.79	1.10	0.67	0.36	0.35	0.18	0.64	0.18	0.35						0.16	0.16		0.16
Sucrose	55.32	56.32		57.00	56.50																		
Triton X-100											30.45			30.45						19.97	19.97		19.97
Water	37.56	38.56	48.90	40.45	40.92	34.40	49.20	53.80	52.64	55.36	54.90	49.43	54.90	55.36	55.00	50.00	50.00	50.00	71.88	71.88	49.75	71.88	
Measured dielectric parameters																							
$\epsilon_r$	46.00	43.40	44.30	41.60	41.20	41.80	42.70	40.9	39.3	41.00	40.40	39.20	39.90	41.00	40.10	37.00	36.80	41.10	40.30	39.20	37.90		
$\sigma$ (S/m)	0.86	0.85	0.90	0.90	0.98	0.97	0.99	1.21	1.39	1.38	1.40	1.40	1.42	1.38	1.41	1.40	1.51	1.55	1.88	1.82	2.46		
Temp (°C)	22	22	20	22	22	22	20	22	22	21	22	20	21	21	20	22	22	20	20	20	20		
Target dielectric parameters (Table 2)																							
$\epsilon_r$	45.30	43.50	41.5	41.50			40.50	40.00						39.80	39.20	38.50							
$\sigma$ (S/m)	0.87	0.87	0.9	0.97			1.20	1.40						1.49	1.80	2.40							

NOTE – Multiple columns for any single frequency are optional recipe #, reference: 1 (Kanda et al. [B185]), 2 (Vigneras [B143]), 3 (Peyman and Gabriel [B119]), 4 (Fukunaga et al [B50])





Product Service

The dielectric properties of the tissue simulant liquids used for the SAR testing at TÜV Product Service Ltd are as follows:-

Fluid Type and Frequency	Relative Permittivity $\epsilon_R$ ( $\epsilon'$ ) Target	Relative Permittivity $\epsilon_R$ ( $\epsilon'$ ) Measured	Conductivity $\sigma$ Target	Conductivity $\sigma$ Measured
Head 1900MHz	40.0	39.57	1.40	1.471

### 3.4 TEST CONDITIONS

#### 3.4.1 Test Laboratory Conditions

Ambient Temperature: Within +15°C to +35°C at 20% RH to 75% RH.  
The actual Temperature during the testing ranged from 22.3°C to 22.4°C.  
The actual Humidity during the testing ranged from 31.8% to 36.6% RH.

#### 3.4.2 Test Fluid Temperature Range

Frequency	1900 MHz
Body / Head Fluid	Head
Min Temperature	22.2°C
Max Temperature	22.3°C

#### 3.4.3 SAR Drift

The SAR Drift was within acceptable limits during scans. The maximum SAR Drift, drift due to the handset electronics, was recorded as 3.920% (0.170dB) for all of the testing.  
The Value 3.920% has been included in the measurement uncertainty for this assessment.

### 3.5 MEASUREMENT UNCERTAINTY

Source of Uncertainty	Description	Tolerance / Uncertainty ± %	Probability distribution	Div	C <sub>i</sub> (10g)	Standard Uncertainty ± % (10g)	V <sub>i</sub> or V <sub>eff</sub>
<i>Measurement System</i>							
Probe calibration	7.2.1	8.73	N	1	1	8.73	∞
Isotropy	7.2.1.2	3.18	R	1.73	1	1.84	∞
Probe angle >30deg	additional	12.00	R	1.73	1	6.93	∞
Boundary effect	7.2.1.5	0.49	R	1.73	1	0.28	∞
Linearity	7.2.1.3	1.00	R	1.73	1	0.58	∞
Detection limits	7.2.1.4	0.00	R	1.73	1	0.00	∞
Readout electronics	7.2.1.6	0.30	N	1	1	0.30	∞
Response time	7.2.1.7	0.00	R	1.73	1	0.00	∞
Integration time (equiv.)	7.2.1.8	1.38	R	1.73	1	0.80	∞
RF ambient conditions	7.2.3.6	3.00	R	1.73	1	1.73	∞
Probe positioner mech. restrictions	7.2.2.1	5.35	R	1.73	1	3.09	∞
Probe positioning with respect to phantom shell	7.2.2.3	5.00	R	1.73	1	2.89	∞
Post-processing	7.2.4	7.00	R	1.73	1	4.04	∞
<i>Test sample related</i>							
Test sample positioning	7.2.2.4	1.50	R	1.73	1	0.87	∞
Device holder uncertainty	7.2.2.4.2	1.73	R	1.73	1	1.00	∞
Drift of output power	7.2.3.4	3.920	R	1.73	1	2.26	∞
<i>Phantom and set-up</i>							
Phantom uncertainty (shape and thickness tolerances)	7.2.2.2	2.01	R	1.73	1	1.16	∞
Liquid conductivity (target)	7.2.3.3	5.00	R	1.73	0.43	1.85	∞
Liquid conductivity (meas.)	7.2.3.3	5.00	N	1	0.43	2.15	∞
Liquid permittivity (target)	7.2.3.4	5.00	R	1.73	0.49	1.41	∞
Liquid permittivity (meas.)	7.2.3.4	3.00	N	1	0.49	1.47	∞
Combined standard uncertainty			RSS			13.65	
Expanded uncertainty (95% confidence interval)			K=2			27.3	



Product Service

## **SECTION 4**

### **PHOTOGRAPHS**

#### 4.1 TEST POSITIONAL PHOTOGRAPHS



Figure 12:  
Positional Photograph of the DECT Headset in LH-Cheek Position Device 1.



Figure 13:  
Positional Photograph of the DECT Headset in LH-Cheek Position Device 1.



Figure 14:  
Positional Photograph of the DECT Headset in RH-Cheek Position Device 1.

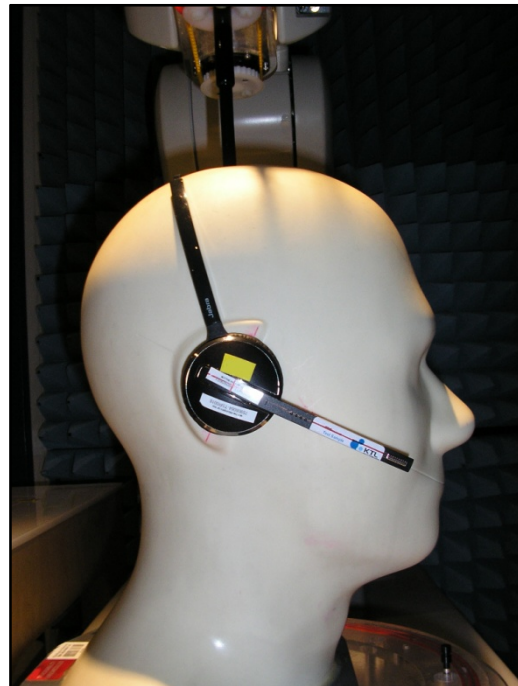

Figure 15:  
Positional Photograph of the DECT Headset in RH-Cheek Position Device 1.



Figure 16:  
Positional Photograph of the DECT  
Headset in RH-Cheek Position Device 2.



Figure 17:  
Positional Photograph of the DECT  
Headset in RH-Cheek Position Device 2.



Figure 18  
Positional Photograph of the DECT  
Headset in RH-Cheek Position Device 3.

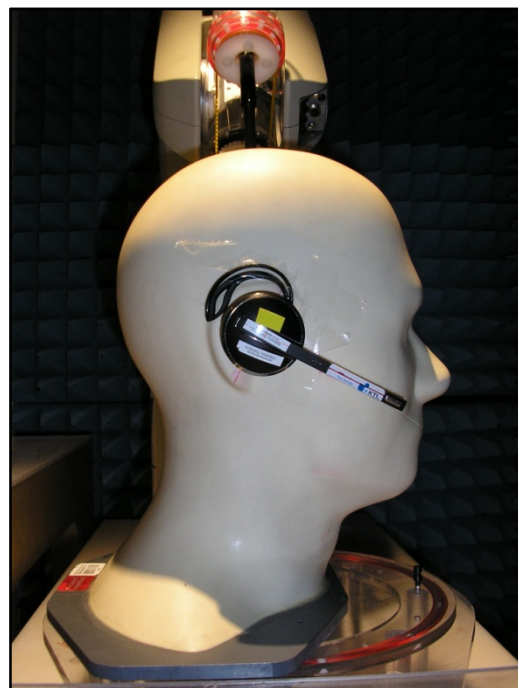

Figure 19:  
Positional Photograph of the DECT  
Headset in RH-Cheek Position Device 3.

#### 4.2 PHOTOGRAPHS OF EQUIPMENT UNDER TEST (EUT)

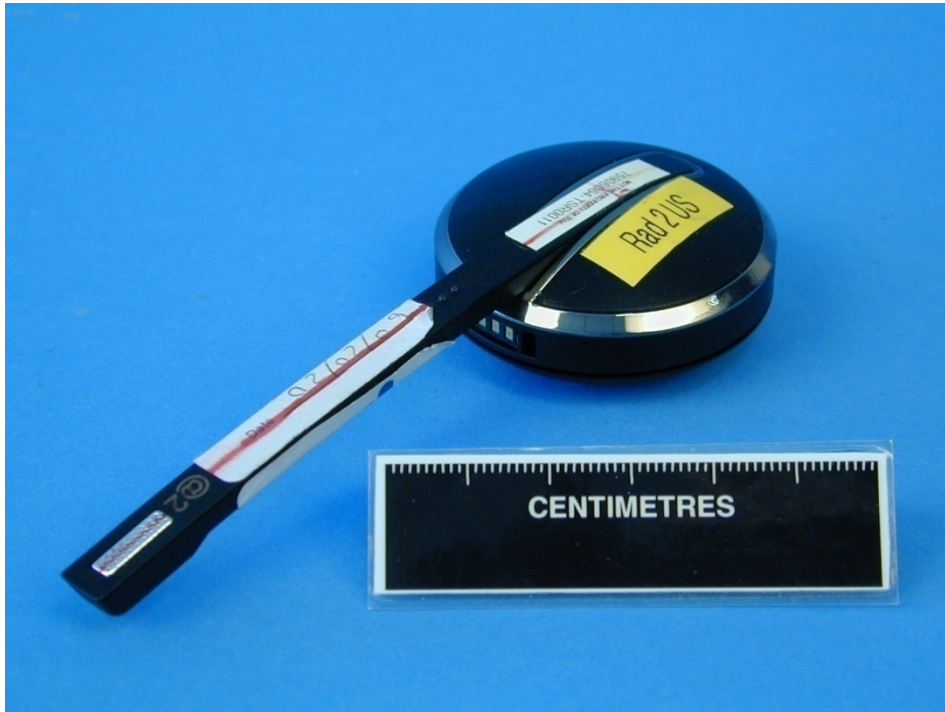

Figure 20:  
Front View – DECT Headset.



Figure 21  
Rear View – DECT Headset.

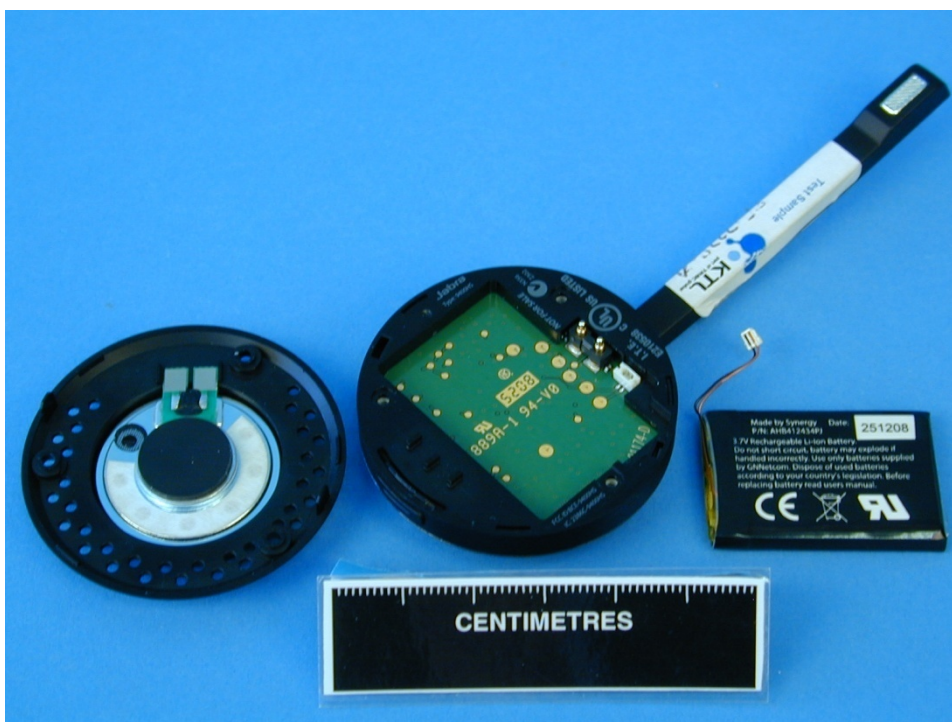

Figure 22:  
Rear View – DECT Headset Battery Removed.



Figure 23:  
Device 1 – DECT Headset Attachment.



Figure 24  
Device 2 – DECT Headset Attachment.



Figure 25  
Device 3 – DECT Headset Attachment.





Product Service

## **SECTION 5**

### **DISCLAIMERS AND COPYRIGHT**



Product Service

## 5.1 DISCLAIMERS AND COPYRIGHT

This report relates only to the actual item/items tested.

This report must not be reproduced, except in its entirety, without the written permission of  
TÜV Product Service Limited

© 2009 TÜV Product Service Limited

## **ANNEX A**

### **PROBE CALIBRATION INFORMATION**



IMMERSIBLE SAR PROBE

CALIBRATION REPORT

Part Number: IXP – 050

S/N 0170

October 2008

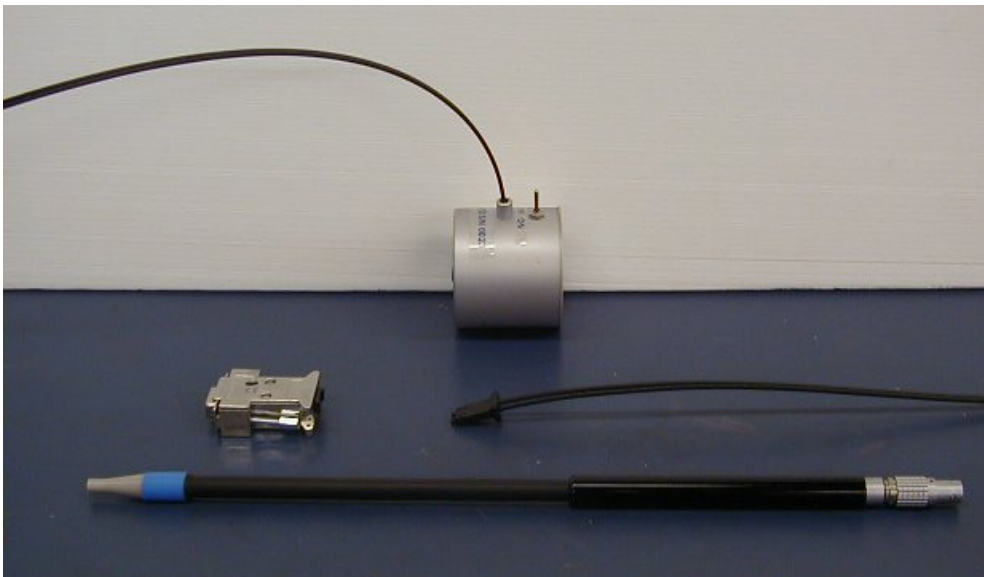

Indexsar Limited

Oakfield House

Cudworth Lane

Newdigate

Surrey RH5 5BG

Tel: +44 (0) 1306 632 870

Fax: +44 (0) 1306 631 834

e-mail: [enquiries@indexsar.com](mailto:enquiries@indexsar.com)

Reproduction of this report is authorized by Indexsar Ltd provided the report is reproduced in its entirety





**Indexsar Limited**  
Oakfield House  
Cudworth Lane  
Newdigate  
Surrey RH5 5BG  
**Tel: +44 (0) 1306 632 870**  
Fax: +44 (0) 1306 631 834  
e-mail: [enquiries@indexsar.com](mailto:enquiries@indexsar.com)

**Calibration Certificate 0810/0170**  
**Date of Issue: 7<sup>th</sup> October 2008**  
**Immersible SAR Probe**

Type:	IXP-050
Manufacturer:	IndexSAR, UK
Serial Number:	0170
Place of Calibration:	IndexSAR, UK
Date of Receipt of Probe:	29 <sup>th</sup> July 2008
Calibration Dates:	9 <sup>th</sup> — 26 <sup>th</sup> September 2008
Customer:	TUV Product Service

*IndexSAR Ltd hereby declares that the IXP-050 Probe named above has been calibrated for conformity to the IEEE 1528 and BSEN 62209-1 standards using the methods described in this calibration document. Where applicable, the standards used in the calibration process are traceable to the UK's National Physical Laboratory.*

Calibrated by:  Technical Manager

Approved by:  Director

Please keep this certificate with the calibration document. When the probe is sent for a calibration check, please include the calibration document.

## INTRODUCTION

This Report presents measured calibration data for a particular Indexsar SAR probe (S/N 0170) only and describes the procedures used for characterisation and calibration.

Indexsar probes are characterised using procedures that, where applicable, follow the recommendations of BSEN 622009-1 [Ref 1] & IEEE [Ref 2] standards. The procedures incorporate techniques for probe linearisation, isotropy assessment and determination of liquid factors (conversion factors). Calibrations are determined by comparing probe readings with analytical computations in canonical test geometries (waveguides) using normalised power inputs.

Each step of the calibration procedure and the equipment used is described in the sections below.

### CALIBRATION PROCEDURE

#### 1. Objectives

The calibration process comprises four stages

- 1) Determination of the channel sensitivity factors which optimise the probe's overall rotational isotropy in 900MHz brain fluid
- 2) Determination of the channel sensitivity factors and angular offset of the X channel which together optimise the probe's spherical isotropy in 900MHz brain fluid
- 3) Numerical combination of the two sets of channel sensitivity factors to give both acceptable rotational isotropy and acceptable spherical isotropy values
- 4) At each frequency of interest, application of these channel sensitivity factors to model the exponential decay of SAR in a waveguide fluid cell, and hence derive the liquid conversion factors at that frequency

#### 2. Probe output

The probe channel output signals are linearised in the manner set out in Refs [1] and [2]. The following equation is utilized for each channel:

$$U_{lin} = U_{o/p} + U_{o/p}^2 / DCP \quad (1)$$

where  $U_{lin}$  is the linearised signal,  $U_{o/p}$  is the raw output signal in mV and DCP is the diode compression potential in similar voltage units.

DCP is determined from fitting equation (1) to measurements of  $U_{lin}$  versus source feed power over the full dynamic range of the probe. The DCP is a characteristic of the Schottky diodes used as the sensors. For the IXP-050 probes with CW signals the DCP values are typically 100mV.

Conventionally, when used in conjunction with the SARA2 test jig, all measured voltages and voltage-derived values are quoted in units of V\*200 eg a DCP value of 100mV corresponds to 20 in V\*200 units. Conversely, in the SARA C and HAC SAR measurement systems, unmodified mV values are used throughout. As a consequence, the cal factors for this probe are listed in two tables, one for SARA2 and one for SARA C / HAC SAR.

In turn, measurements of E-field are determined using the following equation (where output voltages are also in units of mV):

$$E_{liq}^2 \text{ (V/m)} = U_{linx} * \text{Air Factor}_x * \text{Liq Factor}_x + U_{liny} * \text{Air Factor}_y * \text{Liq Factor}_y + U_{linz} * \text{Air Factor}_z * \text{Liq Factor}_z \quad (2)$$

Here, "Air Factor" represents each channel's sensitivity, while "Liq Factor" represents the enhancement in signal level when the probe is immersed in tissue-simulant liquids at each frequency of interest.

#### 3. Selecting channel sensitivity factors to optimise isotropic response

After manufacture, the first stage of the calibration process is to balance the three channels' Air Factor values, thereby optimising the probe's overall axial response ("rotational isotropy").

To do this, a 900MHz waveguide containing head-fluid simulant is selected. Like all waveguides used during probe calibration, this particular waveguide contains two distinct sections: an air-filled launcher section, and a liquid cell section, separated by a dielectric matching window designed to minimise reflections at the air-liquid interface.

The waveguide stands in an upright position and the liquid cell section is filled with 900MHz brain fluid to within 10 mm of the open end. The depth of liquid ensures there is negligible radiation from the waveguide open top and that the probe calibration is not influenced by reflections from nearby objects.

During the measurement, a  $TE_{01}$  mode is launched into the waveguide by means of an N-type-to-waveguide adapter. The probe is then lowered vertically into the liquid until the tip is exactly 10mm above the centre of the dielectric window. This particular separation ensures that the probe is operating in a part of the waveguide where boundary corrections are not necessary.

Care must also be taken that the probe tip is centred while rotating.

The exact power applied to the input of the waveguide during this stage of the probe calibration is immaterial since only relative values are of interest while the probe rotates. However, the power must be sufficiently above the noise floor and free from drift.

The dedicated Indexsar calibration software rotates the probe in 10 degree steps about its axis, and at each position, an Indexsar 'Fast' amplifier samples the probe channels 500 times per second for 0.4 s. The raw  $U_{o/p}$  data from each sample are packed into 10 bytes and transmitted back to the PC controller via an optical cable.  $U_{linx}$ ,  $U_{liny}$  and  $U_{linz}$  are derived from the raw  $U_{o/p}$  values and written to an Excel template.

Once data have been collected from a full probe rotation, the Air Factors are adjusted using a special Excel Solver routine to equalise the output from each channel and hence minimise the rotational isotropy. This automated approach to optimisation removes the effect of human bias.

Figure 6 represents the output from each diode sensor as a function of probe rotation angle.

#### 4. Measurement of Spherical Isotropy

The setup for measuring the probe's spherical isotropy is shown in Figure 2.

A box phantom containing 900MHz head fluid is irradiated by a vertically-polarised, tuned dipole, mounted to the side of the phantom on the robot's seventh axis. During calibration, the spherical response is generated by rotating the probe about its axis in 20 degree steps and changing the dipole polarisation in 10 degree steps.

By using the VPM technique discussed below, an allowance can also be made for the effect of E-field gradient across the probe's spatial extent. This permits values for the probe's effective tip radius and X-channel angular offset to be modelled until the overall spherical isotropy figure is optimised.

The dipole is connected to a signal generator and amplifier via a directional coupler and power meter. As with the determination of rotational isotropy, the absolute power level is not important as long as it is stable.

The probe is positioned within the fluid so that its sensors are at the same vertical height as the centre of the source dipole. The line joining probe to dipole should be perpendicular to the phantom wall, while the horizontal separation between the two should be small enough for VPM corrections to be applicable, without encroaching near the boundary layer of the phantom wall. VPM corrections require a knowledge of the fluid skin depth. This is measured during the calibration by recording the E-field strength while systematically moving the probe away from the dipole in 2mm steps over a 20mm range.

The directionality of the orthogonally-arranged sensors can be checked by analysing the data using dedicated Indexsar software, which displays the data in 3D format, a representative image of which is shown in Figure 3. The left-hand side of this diagram shows the individual channel outputs after linearisation (see above). The program uses these data to balance the channel outputs and then applies an optimisation process, which makes fine adjustments to the channel factors for optimum isotropic response.

#### 5. Determination of Conversion ("Liquid") Factors at each frequency of interest

A lookup table of conversion factors for a probe allows a SAR value to be derived at the measured frequencies, and for either brain or body fluid-simulant.

The method by which the conversion factors are assessed is based on the comparison between measured and analytical rates of decay of SAR with height above a dielectric window. This way, not only can the conversion factors for that frequency/fluid combination be determined, but an allowance can also be made for the scale and range of boundary layer effects.

The theoretical relationship between the SAR at the cross-sectional centre of the lossy waveguide as a function of the longitudinal distance ( $z$ ) from the dielectric separator is given by Equation 3:

$$SAR(z) = \frac{4(P_f - P_b)}{\rho ab \delta} e^{-2z/\delta} \quad (3)$$

Here, the density  $\rho$  is conventionally assumed to be  $1000 \text{ kg/m}^3$ ,  $ab$  is the cross-sectional area of the waveguide, and  $P_f$  and  $P_b$  are the forward and reflected power inside the lossless section of the waveguide, respectively. The penetration depth  $\delta$  (which is the reciprocal of the waveguide-mode attenuation coefficient) is a property of the lossy liquid and is given by Equation (4).

$$\delta = \left[ \text{Re} \left\{ \sqrt{(\pi/a)^2 + j\omega\mu_o(\sigma + j\omega\epsilon_o\epsilon_r)} \right\} \right]^{-1} \quad (4)$$

where  $\sigma$  is the conductivity of the tissue-simulant liquid in S/m,  $\epsilon_r$  is its relative permittivity, and  $\omega$  is the radial frequency (rad/s). Values for  $\sigma$  and  $\epsilon_r$  are obtained prior to each waveguide test using an Indexsar DiLine measurement kit, which uses the TEM method as recommended in [2].  $\sigma$  and  $\epsilon_r$  are both temperature- and fluid-dependent, so are best measured using a sample of the tissue-simulant fluid immediately prior to the actual calibration.

Wherever possible, all DiLine and calibration measurements should be made in the open laboratory at  $22 \pm 2.0^\circ\text{C}$ ; if this is not possible, the values of  $\sigma$  and  $\epsilon_r$  should reflect the actual temperature. Values employed for calibration are listed in the tables below.

By ensuring the liquid height in the waveguide is at least three penetration depths, reflections at the upper surface of the liquid are negligible. The power absorbed in the liquid is therefore determined solely from the waveguide forward and reflected power.

Different waveguides are used for 835/900MHz, 1800/1900MHz, 2450/2600MHz and 5200/5800MHz measurements. Table A.1 of [1] can be used for designing calibration waveguides with a return loss greater than 20 dB at the most important frequencies used for personal wireless communications, and better than 15dB for frequencies greater than 5GHz. Values for the penetration depth for these specific fixtures and tissue-simulating mixtures are also listed in the aforementioned Table A.1.

According to [1], this calibration technique provides excellent accuracy, with standard uncertainty of less than 3.6% depending on the frequency and medium. The calibration itself is reduced to power measurements traceable to a standard calibration procedure. The practical limitation to the frequency band of 800 to 5800 MHz because of the waveguide size is not severe in the context of compliance testing.

During calibration, the probe is lowered carefully until it is just touching the cross-sectional centre of the dielectric window. 200 samples are then taken and written to an Excel template file before moving the probe vertically upwards. This cycle is repeated 150 times. The vertical separation between readings is determined from practical considerations of the expected SAR decay rate, and range from 0.2mm steps at low frequency, through 0.1mm at 2450MHz, down to 0.05mm at 5GHz.

Once the data collection is complete, a Solver routine is run which optimises the measured-theoretical fit by varying the conversion factor, and the boundary correction size and range.



For 450 MHz calibrations, a slightly different technique must be used — the equatorial response of the probe-under-test is compared with the equivalent response of a probe whose 450MHz characteristics have already been determined by NPL. The conversion factor of the probe-under-test can then be deduced.

#### VPM (Virtual Probe Miniaturisation)

SAR probes with 3 diode-sensors in an orthogonal arrangement are designed to display an isotropic response when exposed to a uniform field. However, the probes are ordinarily used for measurements in non-uniform fields and isotropy is not assured when the field gradients are significant compared to the dimensions of the tip containing the three orthogonally-arranged dipole sensors.

It becomes increasingly important to assess the effects of field gradients on SAR probe readings when higher frequencies are being used. For Indexsar IXP-050 probes, which are of 5mm tip diameter, field gradient effects are minor at GSM frequencies, but are major above 5GHz. Smaller probes are less affected by field gradients and so probes, which are significantly less than 5mm diameter, would be better for applications above 5GHz.

The IndexSAR report IXS0223 [4] describes theoretical and experimental studies to evaluate the issues associated with the use of probes at arbitrary angles to surfaces and field directions. Based upon these studies, the procedures and uncertainty analyses referred to in [2] are addressed for the full range of probe presentation angles.

In addition, generalized procedures for correcting for the finite size of immersible SAR probes are developed. Use of these procedures enables application of schemes for virtual probe miniaturization (VPM) – allowing probes of a specific size to be used where physically-smaller probes would otherwise be required.

Given the typical dimensions of 3-channel SAR probes presently available, use of the VPM technique extends the satisfactory measurement range to higher frequencies.

#### CALIBRATION FACTORS MEASURED FOR PROBE S/N 0170

*The probe was calibrated at 450, 835, 900, 1800, 1900, 2100 and 2450 MHz in liquid samples representing brain and body liquid at these frequencies.*

*The calibration was for CW signals only, and the axis of the probe was parallel to the direction of propagation of the incident field i.e. end-on to the incident radiation. The axial isotropy of the probe was measured by rotating the probe about its axis in 10 degree steps through 360 degrees in this orientation.*

The reference point for the calibration is in the centre of the probe's cross-section at a distance of 2.7 mm from the probe tip in the direction of the probe amplifier. A value of 2.7 mm should be used for the tip to sensor offset distance in the software. The distance of 2.7mm for assembled probes has been confirmed by taking X-ray images of the probe tips (see Figure 9).

It is important that the diode compression point and air factors used in the software are the same as those quoted in the results tables, as these are used to convert the diode output voltages to a SAR value.

#### CALIBRATION EQUIPMENT

The table on page 20 indicates the calibration status of all test equipment used during probe calibration.

## MEASUREMENT UNCERTAINTIES

A complete measurement uncertainty analysis for the SARA2 measurement system has been published in Reference [3]. Table 10 from that document is re-created below, and lists the uncertainty factors associated just with the calibration of probes.

Source of uncertainty	Uncertainty value $\pm$ %	Probability distribution	Divisor	$c_i$	Standard uncertainty $u_i \pm$ %	$\nu_i$ or $\nu_{\text{eff}}$
Incident or forward power	5.743	N	1.00	1	5.743	$\infty$
Refelected power	5.773	N	1.00	1	5.773	$\infty$
Liquid conductivity	1.120	N	1.00	1	1.120	$\infty$
Liquid permittivity	1.085	N	1.00	1	1.085	$\infty$
Field homogeneity	0.002	R	1.73	1	0.001	$\infty$
Probe positioning: +/- 0.05mm	0.55	R	1.73	1	0.318	
Influence on Probe pos: 11%/mm						
Field probe linearity	4.7	R	1.73	1	2.714	$\infty$
<b>Combined standard uncertainty</b>		<b>RSS</b>			<b>8.729</b>	

At the 95% confidence level, therefore, the expanded uncertainty is 17.1%

**SUMMARY OF CALIBRATION FACTORS**

*(for use with SARA C & HACSAR)*

	<b>X</b>	<b>Y</b>	<b>Z</b>	<b>Units</b>
<b>Air Factors</b>	84.78	75.34	79.86	(V/m) <sup>2</sup> /mV
<b>CW DCPs</b>	100	100	100	mV

<b>Freq (MHz)</b>	<b>Head</b>			<b>Body</b>		
	<b>SAR Conv Factor</b>	<b>Bound Corr. – f(0)</b>	<b>Bound Corr. – d(mm)</b>	<b>SAR Conv Factor</b>	<b>Bound Corr. – f(0)</b>	<b>Bound Corr. – d(mm)</b>
<b>450</b>	0.294	-	-	0.296	-	-
<b>835</b>	0.273	0.88	1.4	0.279	0.98	1.4
<b>900</b>	0.273	0.95	1.4	0.289	0.92	1.5
<b>1800</b>	0.333	0.93	1.4	0.385	0.71	1.9
<b>1900</b>	0.337	0.87	1.5	0.399	0.71	1.9
<b>2100</b>	0.346	0.75	1.5	0.394	0.64	1.9
<b>2450</b>	0.365	0.77	1.6	0.430	0.61	2.0

<b>Miscellaneous</b>	
Sensor offset	2.7 mm
X Ch. Angle to red dot	6.5°

<b>Measured Isotropy at 900MHz</b>	<b>(+/-) dB</b>
Spherical Isotropy	0.22
Axial Isotropy	0.02

**SUMMARY OF CALIBRATION FACTORS**

(for use with SARA 2)

	<b>X</b>	<b>Y</b>	<b>Z</b>	<b>Units</b>
<b>Air Factors</b>	424	377	399	$(V/m)^2/(V*200)$
<b>CW DCPs</b>	20	20	20	V*200

<b>Freq (MHz)</b>	<b>Head</b>			<b>Body</b>		
	<b>SAR Conv Factor</b>	<b>Bound Corr. – f(0)</b>	<b>Bound Corr. – d(mm)</b>	<b>SAR Conv Factor</b>	<b>Bound Corr. – f(0)</b>	<b>Bound Corr. – d(mm)</b>
<b>450</b>	0.294	-	-	0.296	-	-
<b>835</b>	0.273	0.88	1.4	0.279	0.98	1.4
<b>900</b>	0.273	0.95	1.4	0.289	0.92	1.5
<b>1800</b>	0.333	0.93	1.4	0.385	0.71	1.9
<b>1900</b>	0.337	0.87	1.5	0.399	0.71	1.9
<b>2100</b>	0.346	0.75	1.5	0.394	0.64	1.9
<b>2450</b>	0.365	0.77	1.6	0.430	0.61	2.0

<b>Miscellaneous</b>	
Tip radius	1.25 mm
X Ch. Angle to red dot	6.5°

<b>Measured Isotropy at 900MHz</b>	<b>(+/-) dB</b>
Spherical Isotropy	0.22
Axial Isotropy	0.02

## PROBE SPECIFICATIONS

Indexsar probe 0170, along with its calibration, is compared with BSEN 62209-1 and IEEE standards recommendations (Refs [1] and [2]) in the Tables below. A listing of relevant specifications is contained in the tables below:

<b>1.1.1 Dimensions</b>	S/N 0170	BSEN [1]	IEEE [2]
Overall length (mm)	350		
Tip length (mm)	10		
Body diameter (mm)	12		
Tip diameter (mm)	5.2	8	8
Distance from probe tip to dipole centers (mm)	2.7		

<b>1.1.2 Dynamic range</b>	S/N 0170	BSEN [1]	IEEE [2]
Minimum (W/kg)	0.01	<0.02	0.01
Maximum (W/kg) N.B. only measured to > 100 W/kg on representative probes	>100	>100	100

<b>1.1.3 Isotropy (measured at 900MHz)</b>	S/N 0170	BSEN [1]	IEEE [2]
Axial rotation with probe normal to source (+/- dB)	0.02 (See table above)	0.5	0.25
Spherical isotropy covering all orientations to source (+/- dB)	0.22	1.0	0.50

<b>1.1.4 Construction</b>	Each probe contains three orthogonal dipole sensors arranged on a triangular prism core, protected against static charges by built-in shielding, and covered at the tip by PEEK cylindrical enclosure material. Outer case materials are PEEK and adhesive-lined heat-shrink sleeving.
<b>1.1.5 Chemical resistance</b>	Tested to be resistant to glycol, Indexsar-supplied liquids based on sugar/salt/Tween in the long term, and alcohol containing simulant liquids in the short term, but probes should be removed, cleaned and dried when not in use.

## REFERENCES

- [1] BSEN 62209-1:2006. Human exposure to radio frequency fields from hand-held and body-mounted wireless communication devices — Human models, instrumentation, and procedures — Part 1: Procedure to determine the specific absorption rate (SAR) for hand-held devices used in close proximity to the ear (frequency range of 300 MHz to 3 GHz)
- [2] IEEE 1528, 2003 Recommended Practice for Determining the Peak Spatial-Average Specific Absorption Rate (SAR) in the Human Head from Wireless Communications Devices: Measurement Techniques
- [3] Indexsar Report IXS-0300, October 2007. Measurement uncertainties for the SARA2 system assessed against the recommendations of BS EN 62209-1:2006
- [4] Indexsar Report IXS-0223, May 2003. Compensating for the finite size of SAR probes used in electric field gradients

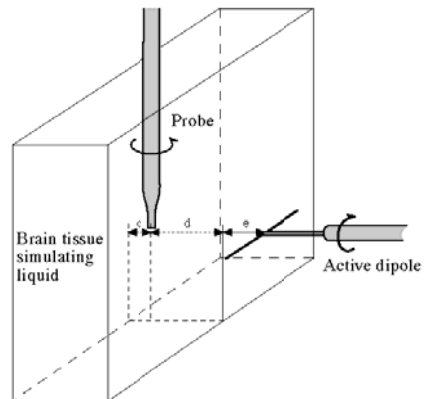

Figure 1. Spherical isotropy jig showing probe, dipole and box filled with simulated brain liquid (see Ref [2], Section A.5.2.1)

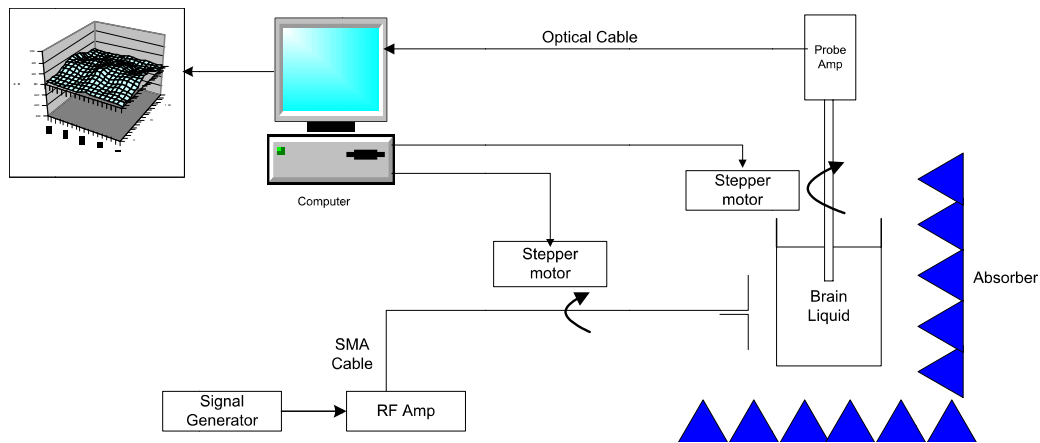

Figure 2 Schematic diagram of the test geometry used for isotropy determination

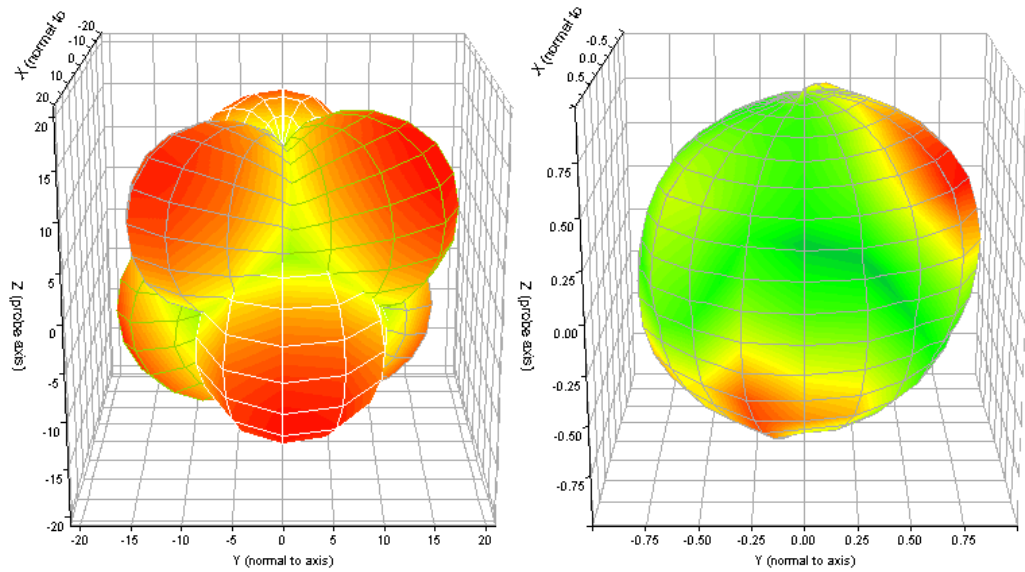

Figure 3 Graphical representation of probe 0170's response to fields applied from each direction. The diagram on the left shows the individual response characteristics of each of the three channels and the diagram on the right shows the resulting probe sensitivity in each direction. The colour range in the figure images the lowest values as blue and the maximum values as red. For probe S/N 0170, this range is (+/-) 0.22dB.

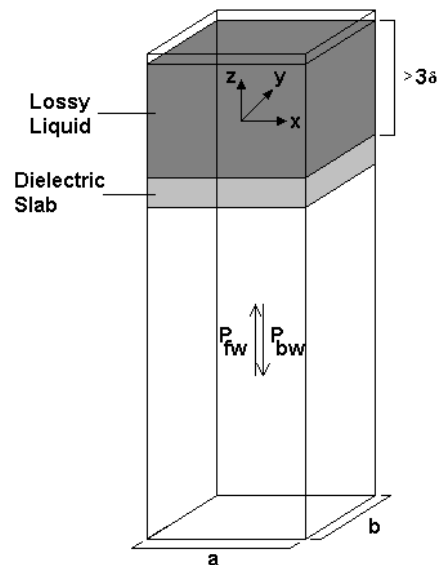

Figure 4 Geometry used for waveguide calibration (after Ref [2]. Section A.3.2.2)



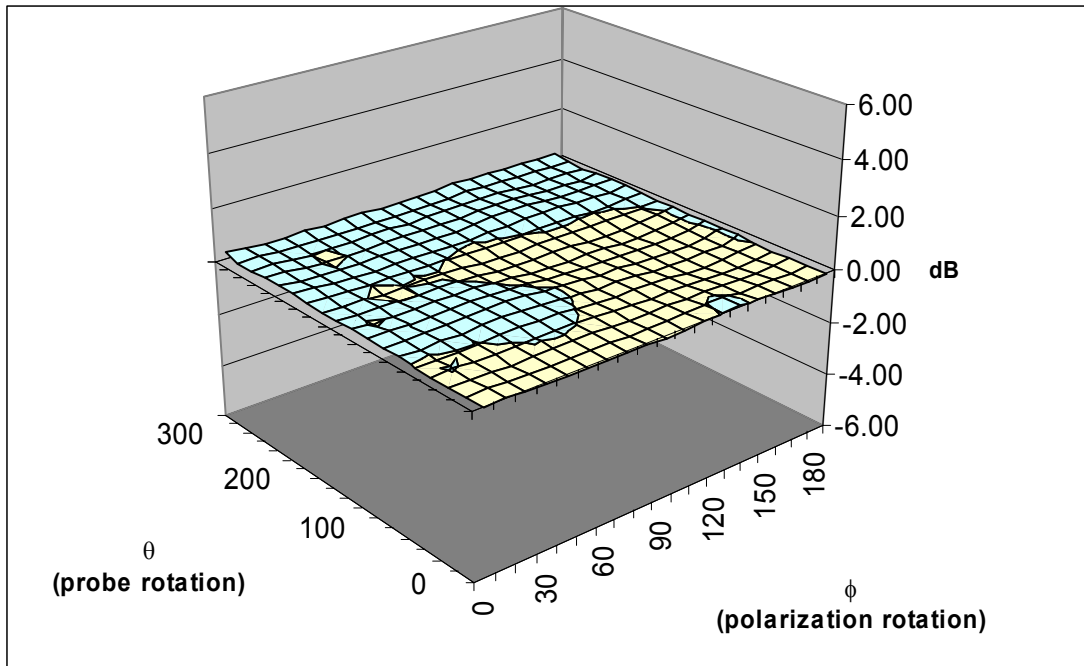

Figure 5 Surface Isotropy diagram of IXP-050 Probe S/N 0170 at 900MHz after VPM (rotational isotropy axial  $\pm 0.02$ dB, spherical isotropy  $\pm 0.22$ dB)

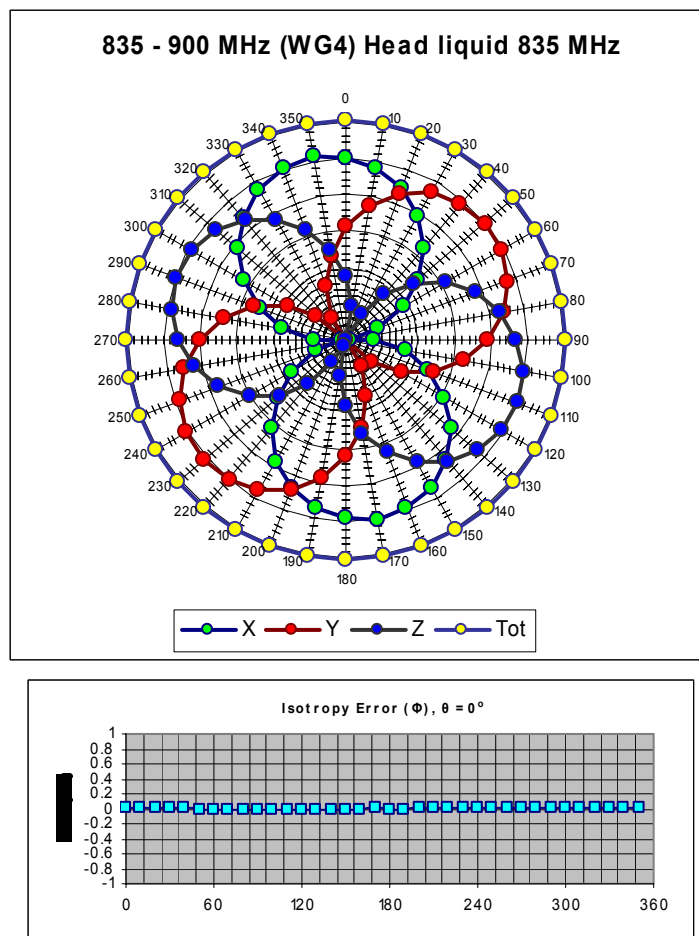

Figure 6. The rotational isotropy of probe S/N 0170 obtained by rotating the probe in a liquid-filled waveguide at 900 MHz.

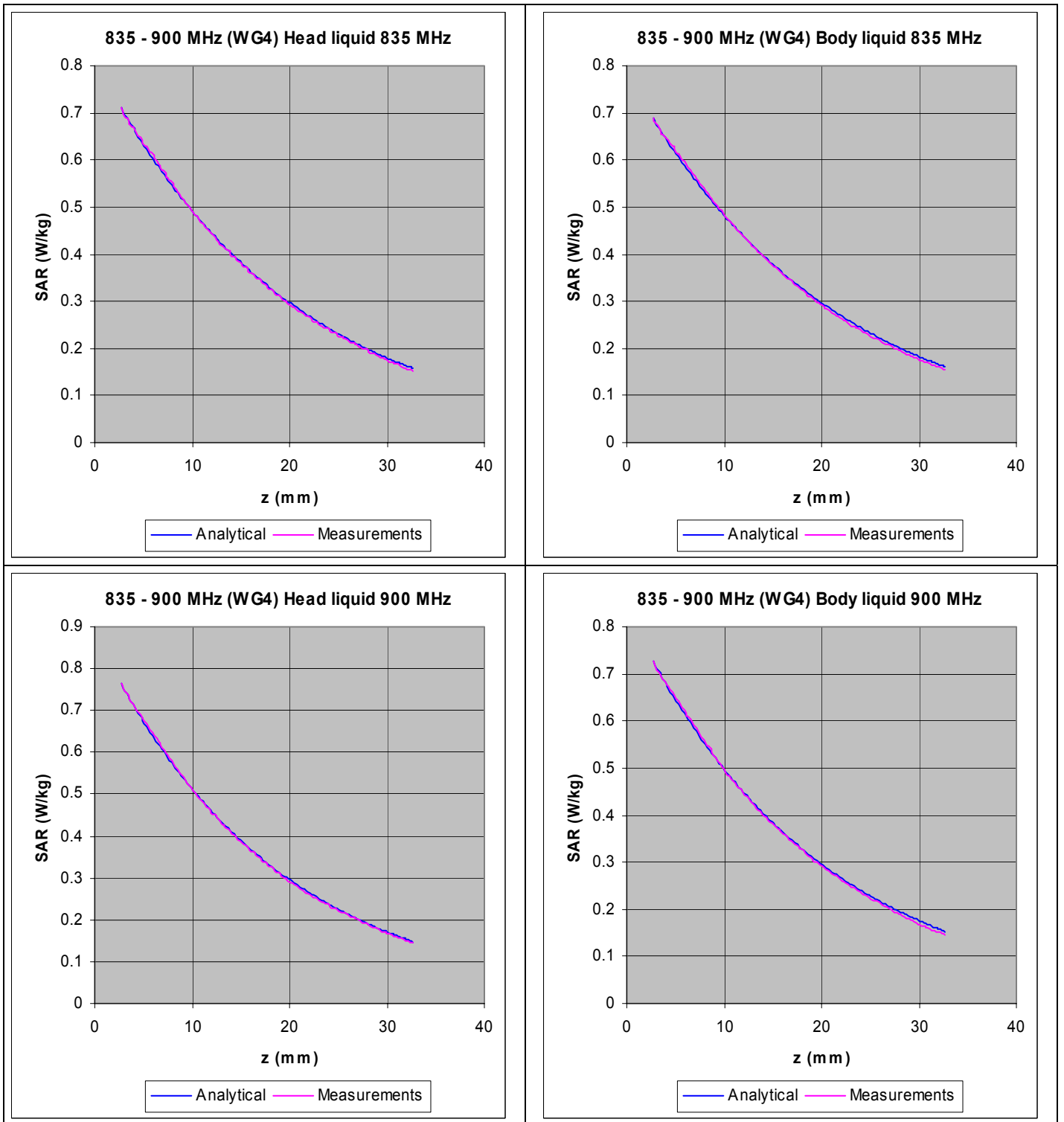
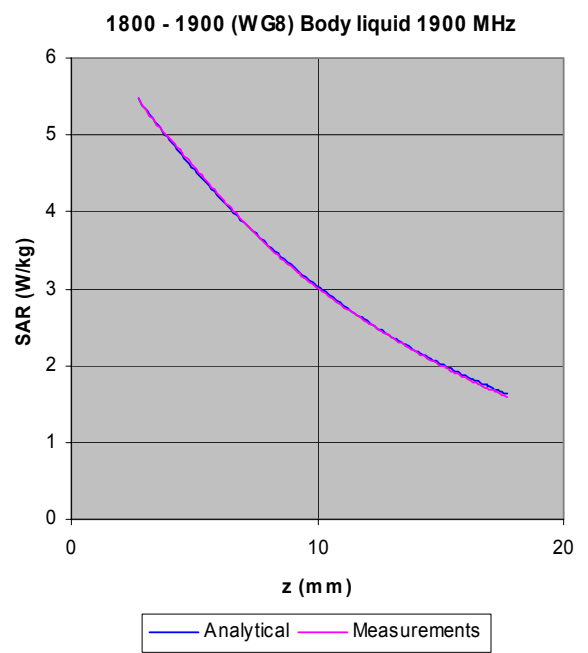
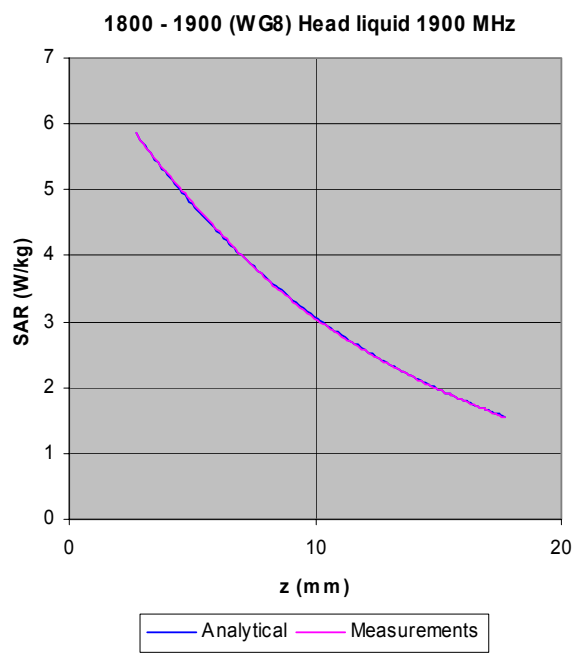
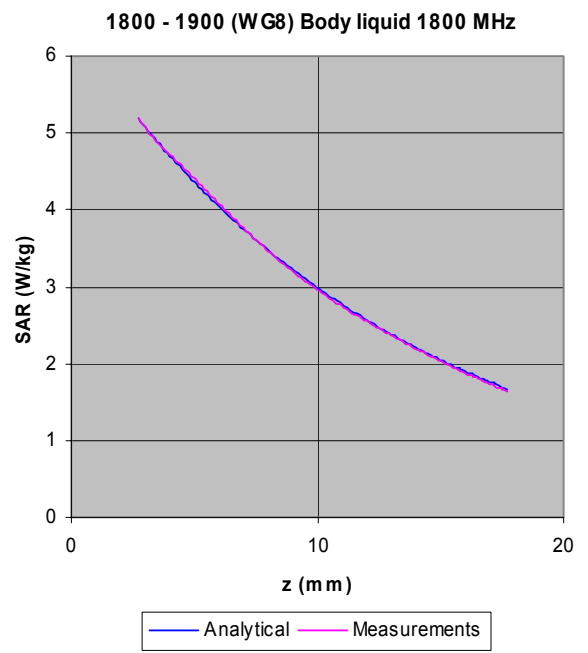
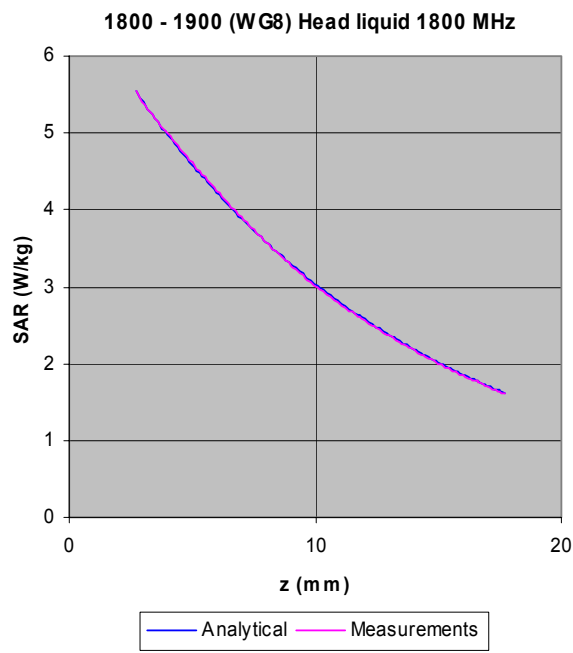

Figure 7. The measured SAR decay function along the centreline of the WG4 waveguide with conversion factors adjusted to fit to the theoretical function for the particular dimension, frequency, power and liquid properties employed.



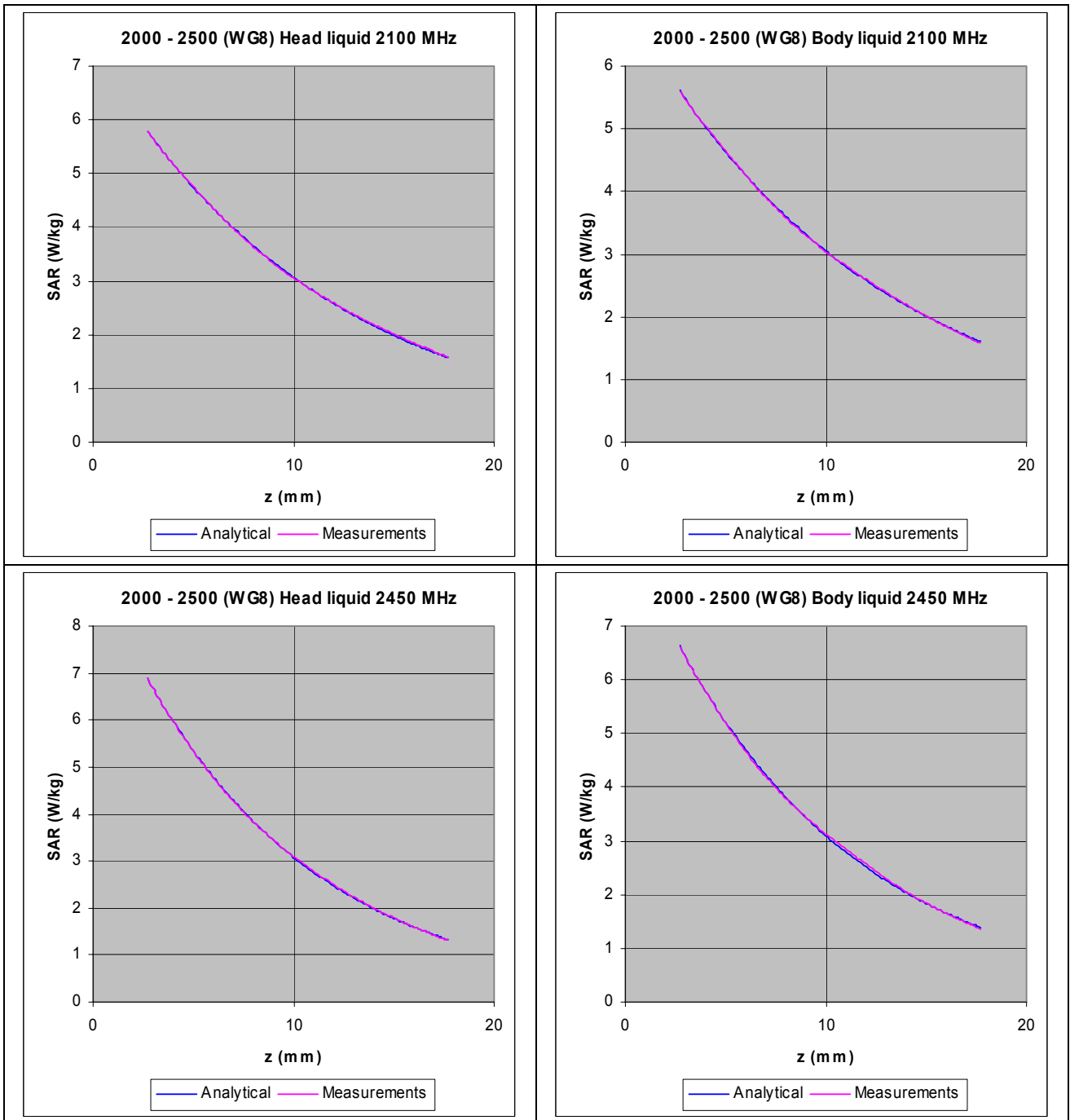

Figure 8. The measured SAR decay function along the centreline of the WG8 waveguide with conversion factors adjusted to fit to the theoretical function for the particular dimension, frequency, power and liquid properties employed.

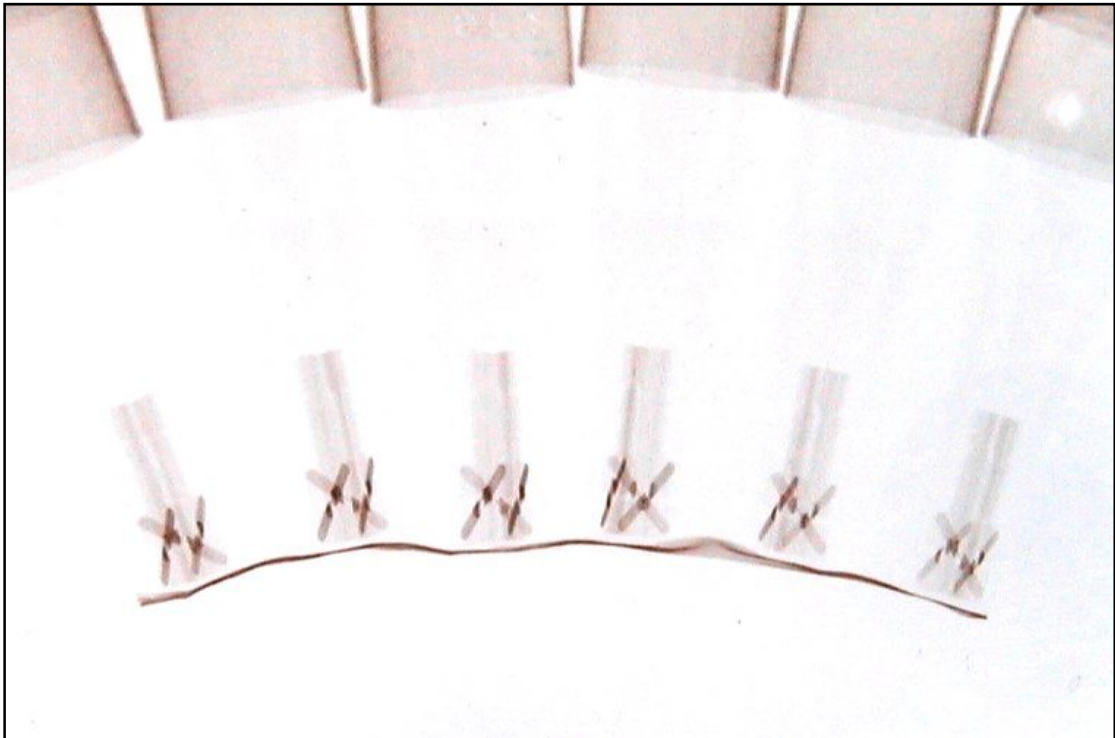

Figure 9: X-ray positive image of 5mm probes

**Table indicating the dielectric parameters of the liquids used for calibrations at each frequency**

<b>Frequency (MHz)</b>	<b>BRAIN</b>		<b>BODY</b>	
	<b>Relative permittivity (measured)</b>	<b>Conductivity (S/m) (measured)</b>	<b>Relative permittivity (measured)</b>	<b>Conductivity (S/m) (measured)</b>
450	44.73	0.84	56.65	0.73
835	41.70	0.89	55.23	0.98
900	40.92	0.96	54.59	1.04
1800	40.01	1.41	53.44	1.49
1900	39.57	1.51	53.11	1.59
2100	39.55	1.48	53.43	1.64
2450	38.14	1.84	52.34	2.03

**Table of test equipment calibration status**

<b>Instrument description</b>	<b>Supplier / Manufacturer</b>	<b>Model</b>	<b>Serial No.</b>	<b>Last calibration date</b>	<b>Calibration due date</b>
Power sensor	Rohde & Schwarz	NRP-Z23	100063	16/06/2008	16/6/2010
Dielectric property measurement	Indexasar	DiLine (sensor lengths: 160mm, 80mm and 60mm)	N/A	(absolute) – checked against NPL values using reference liquids	N/A
Vector network analyser	Anritsu	MS6423B	003102	09/10/2007	09/10/2009
SMA autocalibration module	Anritsu	36581KKF/1	001902	09/10/2007	09/10/2009