



RADIO TEST REPORT

Test Report No. : 13477241H-A-R1

Applicant : CASIO COMPUTER CO., LTD

Type of EUT : Wireless MIDI & audio adaptor

Model Number of EUT : WU-BT10

FCC ID : BBQWUBT10

Test regulation : FCC Part 15 Subpart C: 2020
*Bluetooth Low Energy part

Test Result : Complied (Refer to SECTION 3.2)

1. This test report shall not be reproduced in full or partial, without the written approval of UL Japan, Inc.
2. The results in this report apply only to the sample tested.
3. This sample tested is in compliance with the limits of the above regulation.
4. The test results in this test report are traceable to the national or international standards.
5. This test report must not be used by the customer to claim product certification, approval, or endorsement by the A2LA accreditation body.
6. This test report covers Radio technical requirements.
It does not cover administrative issues such as Manual or non-Radio test related Requirements. (if applicable)
7. The all test items in this test report are conducted by UL Japan, Inc. Ise EMC Lab.
8. The opinions and the interpretations to the result of the description in this report are outside scopes where UL Japan has been accredited.
9. The information provided from the customer for this report is identified in Section 1.
10. This report is a revised version of 13477241H-A. 13477241H-A is replaced with this report.

Date of test: November 2 to 4, 2020

Representative test engineer: 
Yuta Moriya
Engineer
Consumer Technology Division

Approved by: 
Takumi Shimada
Engineer
Consumer Technology Division



CERTIFICATE 5107.02

- The testing in which "Non-accreditation" is displayed is outside the accreditation scopes in UL Japan.
 There is no testing item of "Non-accreditation".

UL Japan, Inc.

Ise EMC Lab.

4383-326 Asama-cho, Ise-shi, Mie-ken 516-0021 JAPAN

Telephone : +81 596 24 8999

Facsimile : +81 596 24 8124

REVISION HISTORY

Original Test Report No.: 13477241H-A

Revision	Test report No.	Date	Page revised	Contents
- (Original)	13477241H-A	November 25, 2020	-	-
1	13477241H-A-R1	January 20, 2021	P10	Added explanatory note: "Setting value might be different from product specification value"

UL Japan, Inc.

Ise EMC Lab.

4383-326 Asama-cho, Ise-shi, Mie-ken 516-0021 JAPAN

Telephone : +81 596 24 8999

Facsimile : +81 596 24 8124

Reference: Abbreviations (Including words undescribed in this report)

A2LA	The American Association for Laboratory Accreditation	MCS	Modulation and Coding Scheme
AC	Alternating Current	MRA	Mutual Recognition Arrangement
AFH	Adaptive Frequency Hopping	N/A	Not Applicable
AM	Amplitude Modulation	NIST	National Institute of Standards and Technology
Amp, AMP	Amplifier	NS	No signal detect.
ANSI	American National Standards Institute	NSA	Normalized Site Attenuation
Ant, ANT	Antenna	NVLAP	National Voluntary Laboratory Accreditation Program
AP	Access Point	OBW	Occupied Band Width
ASK	Amplitude Shift Keying	OFDM	Orthogonal Frequency Division Multiplexing
Atten., ATT	Attenuator	P/M	Power meter
AV	Average	PCB	Printed Circuit Board
BPSK	Binary Phase-Shift Keying	PER	Packet Error Rate
BR	Bluetooth Basic Rate	PHY	Physical Layer
BT	Bluetooth	PK	Peak
BT LE	Bluetooth Low Energy	PN	Pseudo random Noise
BW	BandWidth	PRBS	Pseudo-Random Bit Sequence
Cal Int	Calibration Interval	PSD	Power Spectral Density
CCK	Complementary Code Keying	QAM	Quadrature Amplitude Modulation
Ch., CH	Channel	QP	Quasi-Peak
CISPR	Comite International Special des Perturbations Radioelectriques	QPSK	Quadri-Phase Shift Keying
CW	Continuous Wave	RBW	Resolution Band Width
DBPSK	Differential BPSK	RDS	Radio Data System
DC	Direct Current	RE	Radio Equipment
D-factor	Distance factor	RF	Radio Frequency
DFS	Dynamic Frequency Selection	RMS	Root Mean Square
DQPSK	Differential QPSK	RSS	Radio Standards Specifications
DSSS	Direct Sequence Spread Spectrum	Rx	Receiving
EDR	Enhanced Data Rate	SA, S/A	Spectrum Analyzer
EIRP, e.i.r.p.	Equivalent Isotropically Radiated Power	SG	Signal Generator
EMC	ElectroMagnetic Compatibility	SVSWR	Site-Voltage Standing Wave Ratio
EMI	ElectroMagnetic Interference	TR	Test Receiver
EN	European Norm	Tx	Transmitting
ERP, e.r.p.	Effective Radiated Power	VBW	Video BandWidth
EU	European Union	Vert.	Vertical
EUT	Equipment Under Test	WLAN	Wireless LAN
Fac.	Factor		
FCC	Federal Communications Commission		
FHSS	Frequency Hopping Spread Spectrum		
FM	Frequency Modulation		
Freq.	Frequency		
FSK	Frequency Shift Keying		
GFSK	Gaussian Frequency-Shift Keying		
GNSS	Global Navigation Satellite System		
GPS	Global Positioning System		
Hori.	Horizontal		
ICES	Interference-Causing Equipment Standard		
IEC	International Electrotechnical Commission		
IEEE	Institute of Electrical and Electronics Engineers		
IF	Intermediate Frequency		
ILAC	International Laboratory Accreditation Conference		
ISED	Innovation, Science and Economic Development Canada		
ISO	International Organization for Standardization		
JAB	Japan Accreditation Board		
LAN	Local Area Network		
LIMS	Laboratory Information Management System		

CONTENTS	PAGE
SECTION 1: Customer information.....	5
SECTION 2: Equipment under test (EUT).....	5
SECTION 3: Test specification, procedures & results.....	6
SECTION 4: Operation of EUT during testing.....	10
SECTION 5: Conducted Emission.....	13
SECTION 6: Radiated Spurious Emission	14
SECTION 7: Antenna Terminal Conducted Tests.....	16
APPENDIX 1: Test data	17
Conducted Emission	17
6 dB Bandwidth and 99 % Occupied Bandwidth.....	21
Maximum Peak Output Power	24
Average Output Power	25
Radiated Spurious Emission	27
Conducted Spurious Emission	38
Power Density	44
APPENDIX 2: Test instruments	46
APPENDIX 3: Photographs of test setup	48
Conducted Emission	48
Radiated Spurious Emission	49
Worst Case Position	50
Antenna Terminal Conducted Tests.....	51

SECTION 1: Customer information

Company Name : CASIO COMPUTER CO., LTD
Address : 2-1 Sakaecho 3-chome, Hamura-shi Tokyo 205-8555, Japan
Telephone Number : +81-42-579-7282
Facsimile Number : +81-42-579-7702
Contact Person : Shuji Yamashita

The information provided from the customer is as follows;

- Applicant, Type of EUT, Model Number of EUT, FCC ID on the cover and other relevant pages
 - Operating/Test Mode(s) (Mode(s)) on all the relevant pages
 - SECTION 1: Customer information
 - SECTION 2: Equipment under test (EUT) other than the Receipt Date
 - SECTION 4: Operation of EUT during testing
- * The laboratory is exempted from liability of any test results affected from the above information in SECTION 2 and 4.

SECTION 2: Equipment under test (EUT)

2.1 Identification of EUT

Type : Wireless MIDI & audio adaptor
Model Number : WU-BT10
Serial Number : Refer to SECTION 4.2
Rating : DC 5 V
Receipt Date : October 16, 2020
Country of Mass-production : China
Condition : Engineering prototype
(Not for Sale: This sample is equivalent to mass-produced items.)
Modification : No Modification by the test lab.

2.2 Product Description

Model: WU-BT10 (referred to as the EUT in this report) is a Wireless MIDI & audio adaptor.

General Specification

Operating Temperature : -5 deg. C to +45 deg. C

Radio Specification

Bluetooth (BR / EDR / Low Energy)

Radio Type : Transceiver
Frequency of Operation : 2402 MHz - 2480 MHz
Modulation : BT: FHSS (GFSK, $\pi/4$ DQPSK, 8DPSK)
BT LE: GFSK
Antenna type : PCB Pattern Antenna
Antenna Gain : 1.51 dBi
Clock frequency : 24 MHz

*This test report applies to Bluetooth Low Energy part.

SECTION 3: Test specification, procedures & results

3.1 Test Specification

Test Specification : FCC Part 15 Subpart C
FCC Part 15 final revised on October 13, 2020

Title : FCC 47 CFR Part 15 Radio Frequency Device Subpart C Intentional Radiators
Section 15.207 Conducted limits
Section 15.247 Operation within the bands 902-928 MHz, 2400-2483.5 MHz,
and 5725-5850 MHz

* Also the EUT complies with FCC Part 15 Subpart B.

3.2 Procedures and results

Item	Test Procedure	Specification	Worst margin	Results	Remarks
Conducted Emission	FCC: ANSI C63.10-2013 6. Standard test methods ----- ISED: RSS-Gen 8.8	FCC: Section 15.207 ----- ISED: RSS-Gen 8.8	11.55 dB, 22.52811 MHz, AV, Phase: L	Complied a)	-
6dB Bandwidth	FCC: KDB 558074 D01 15.247 Meas Guidance v05r02 ----- ISED: -	FCC: Section 15.247(a)(2) ----- ISED: RSS-247 5.2(a)	See data.	Complied b)	Conducted
Maximum Peak Output Power	FCC: KDB 558074 D01 15.247 Meas Guidance v05r02 ----- ISED: RSS-Gen 6.12	FCC: Section 15.247(b)(3) ----- ISED: RSS-247 5.4(d)		Complied c)	Conducted
Power Density	FCC: KDB 558074 D01 15.247 Meas Guidance v05r02 ----- ISED: -	FCC: Section 15.247(e) ----- ISED: RSS-247 5.2(b)		Complied d)	Conducted
Spurious Emission Restricted Band Edges	FCC: KDB 558074 D01 15.247 Meas Guidance v05r02 ----- ISED: RSS-Gen 6.13	FCC: Section 15.247(d) ----- ISED: RSS-247 5.5 RSS-Gen 8.9 RSS-Gen 8.10		6.0 dB 2483.500 MHz, AV, Horizontal	Complied e), f)

Note: UL Japan, Inc.'s EMI Work Procedures No. 13-EM-W0420 and 13-EM-W0422.

*1) Radiated test was selected over 30 MHz based on section 15.247(d) and KDB 558074 D01 15.247 Meas Guidance v05r02 8.5 and 8.6.

- a) Refer to APPENDIX 1 (data of Conducted Emission)
- b) Refer to APPENDIX 1 (data of 6 dB Bandwidth and 99 % Occupied Bandwidth)
- c) Refer to APPENDIX 1 (data of Maximum Peak Output Power)
- d) Refer to APPENDIX 1 (data of Power Density)
- e) Refer to APPENDIX 1 (data of Conducted Spurious Emission)
- f) Refer to APPENDIX 1 (data of Radiated Spurious Emission)

Symbols:

Complied The data of this test item has enough margin, more than the measurement uncertainty.

Complied# The data of this test item meets the limits unless the measurement uncertainty is taken into consideration.

* In case any questions arise about test procedure, ANSI C63.10: 2013 is also referred.

UL Japan, Inc.

Ise EMC Lab.

4383-326 Asama-cho, Ise-shi, Mie-ken 516-0021 JAPAN

Telephone : +81 596 24 8999

Facsimile : +81 596 24 8124

FCC Part 15.31 (e)

This EUT provides the stable voltage constantly to RF part regardless of input voltage. Therefore, this EUT complies with the requirement.

FCC Part 15.203 Antenna requirement

It is impossible for end users to replace the antenna, because the antenna is mounted inside of the EUT. Therefore, the equipment complies with the antenna requirement of Section 15.203.

3.3 Addition to standard

Item	Test Procedure	Specification	Worst margin	Results	Remarks
99% Occupied Bandwidth	ISED: RSS-Gen 6.7	ISED: -	N/A	- a)	Conducted
a) Refer to APPENDIX 1 (data of 6 dB Bandwidth and 99 % Occupied Bandwidth)					

Other than above, no addition, exclusion nor deviation has been made from the standard.

3.4 Uncertainty

There is no applicable rule of uncertainty in this applied standard. Therefore, the results are derived depending on whether or not laboratory uncertainty is applied.

The following uncertainties have been calculated to provide a confidence level of 95 % using a coverage factor $k=2$.
Ise EMC Lab.

Antenna Terminal test

Test Item	Uncertainty (+/-)
20 dB Bandwidth / 99 % Occupied Bandwidth	0.96 %
Maximum Peak Output Power / Average Output Power	1.4 dB
Carrier Frequency Separation	0.42 %
Dwell time / Burst rate	0.10 %
Conducted Spurious Emission	2.6 dB

Conducted emission

using Item	Frequency range	Uncertainty (+/-)
AMN (LISN)	0.009 MHz to 0.15 MHz	3.4 dB
	0.15 MHz to 30 MHz	2.9 dB

Radiated emission

Measurement distance	Frequency range	Uncertainty (+/-)
3 m	9 kHz to 30 MHz	3.3 dB
10 m		3.2 dB
3 m	30 MHz to 200 MHz (Horizontal) (Vertical)	4.8 dB
		5.0 dB
	200 MHz to 1000 MHz (Horizontal) (Vertical)	5.2 dB
		6.3 dB
10 m	30 MHz to 200 MHz (Horizontal) (Vertical)	4.8 dB
		4.8 dB
	200 MHz to 1000 MHz (Horizontal) (Vertical)	5.0 dB
		5.0 dB
3 m	1 GHz to 6 GHz	4.9 dB
	6 GHz to 18 GHz	5.2 dB
1 m	10 GHz to 26.5 GHz	5.5 dB
	26.5 GHz to 40 GHz	5.5 dB
10 m	1 GHz to 18 GHz	5.2 dB

3.5 Test Location

UL Japan, Inc. Ise EMC Lab.

*A2LA Certificate Number: 5107.02 / FCC Test Firm Registration Number: 199967 / ISED Lab Company Number: 2973C
4383-326 Asama-cho, Ise-shi, Mie-ken 516-0021 JAPAN
Telephone: +81 596 24 8999, Facsimile: +81 596 24 8124

Test site	Width x Depth x Height (m)	Size of reference ground plane (m) / horizontal conducting plane	Other rooms	Maximum measurement distance
No.1 semi-anechoic chamber	19.2 x 11.2 x 7.7	7.0 x 6.0	No.1 Power source room	10 m
No.2 semi-anechoic chamber	7.5 x 5.8 x 5.2	4.0 x 4.0	-	3 m
No.3 semi-anechoic chamber	12.0 x 8.5 x 5.9	6.8 x 5.75	No.3 Preparation room	3 m
No.3 shielded room	4.0 x 6.0 x 2.7	N/A	-	-
No.4 semi-anechoic chamber	12.0 x 8.5 x 5.9	6.8 x 5.75	No.4 Preparation room	3 m
No.4 shielded room	4.0 x 6.0 x 2.7	N/A	-	-
No.5 semi-anechoic chamber	6.0 x 6.0 x 3.9	6.0 x 6.0	-	-
No.5 measurement room	6.4 x 6.4 x 3.0	6.4 x 6.4	-	-
No.6 shielded room	4.0 x 4.5 x 2.7	4.0 x 4.5	-	-
No.6 measurement room	4.75 x 5.4 x 3.0	4.75 x 4.15	-	-
No.7 shielded room	4.7 x 7.5 x 2.7	4.7 x 7.5	-	-
No.8 measurement room	3.1 x 5.0 x 2.7	3.1 x 5.0	-	-
No.9 measurement room	8.8 x 4.6 x 2.8	2.4 x 2.4	-	-
No.11 measurement room	6.2 x 4.7 x 3.0	4.8 x 4.6	-	-

* Size of vertical conducting plane (for Conducted Emission test) : 2.0 x 2.0 m for No.1, No.2, No.3, and No.4 semi-anechoic chambers and No.3 and No.4 shielded rooms.

3.6 Test data, Test instruments, and Test set up

Refer to APPENDIX.

SECTION 4: Operation of EUT during testing

4.1 Operating Mode(s)

Mode	Remarks*
Bluetooth Low Energy (BT LE) 1M-PHY Uncoded PHY (1M-PHY)	Maximum Packet Size, PRBS9
Bluetooth Low Energy (BT LE) 2M-PHY Uncoded PHY (2M-PHY)	Maximum Packet Size, PRBS9
<p>*Power of the EUT was set by the software as follows (Setting value might be different from product specification value);</p> <p>Power settings: 1M-PHY: 8 dBm 2M-PHY: 8 dBm</p> <p>Software: Airoha Tool Kit version 2.3.13 (Date: July 22, 2020, Storage location: EUT memory)</p> <p>*This setting of software is the worst case. Any conditions under the normal use do not exceed the condition of setting. In addition, end users cannot change the settings of the output power of the product.</p>	

*The details of Operating mode(s)

Test Item	Operating Mode	Tested frequency
Conducted Emission, Radiated Spurious Emission, Maximum Peak Output Power, Power Density, 6dB Bandwidth, 99% Occupied Bandwidth, Conducted Spurious Emission	BT LE, 1M-PHY BT LE, 2M-PHY	2402 MHz 2440 MHz 2480 MHz

4.2 Configuration and peripherals

Antenna Terminal Conducted Tests

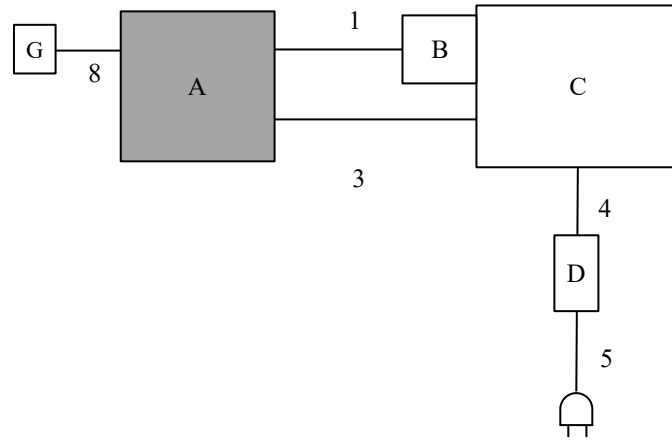

AC 120 V / 60 Hz

Conducted Emission test

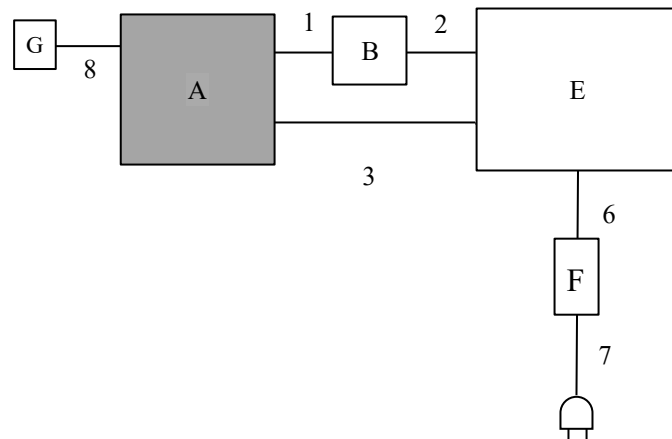

AC 120 V / 60 Hz

Radiated Spurious Emission test

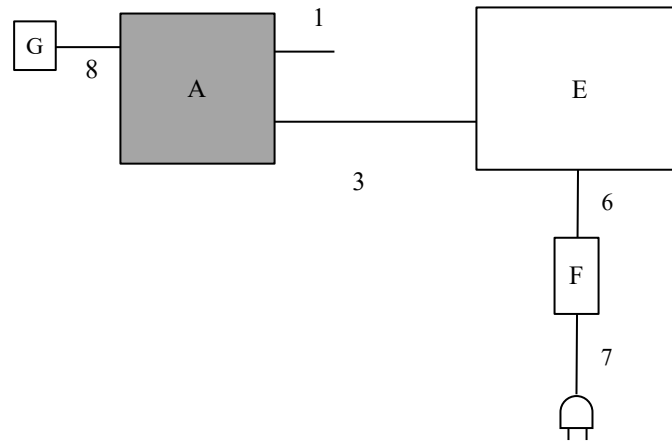

AC 120 V / 60 Hz

* Cabling and setup(s) were taken into consideration and test data was taken under worse case conditions.

Description of EUT and Support equipment

No.	Item	Model number	Serial number	Manufacturer	Remark
A	Wireless MIDI & audio adaptor	WU-BT10	BT1AAC009000021VVV	CASIO COMPUTER CO., LTD	EUT
B	UART download board	C295	-	AIROHA	*1)
C	Laptop PC	X1 Carbon	R9-OH8OBW 15/9	Lenovo	-
D	AC Adapter	ADLX45NCC2A	45N0475	Lenovo	-
E	Laptop PC	PR734MAA447AD73	6G060524H	TOSHIBA	-
F	AC Adapter	PA3917U-1ACA	201140320519358	TOSHIBA	-
G	Switch	-	-	-	*1)

List of cables used

No.	Name	Length (m)	Shield		Remark
			Cable	Connector	
1	Signal Cable	0.15	Unshielded	Unshielded	*1)
2	USB Cable	2.00	Shielded	Shielded	-
3	USB Cable	2.00	Shielded	Shielded	-
4	DC Cable	1.80	Unshielded	Unshielded	-
5	AC Cable	0.90	Unshielded	Unshielded	-
6	DC Cable	1.60	Unshielded	Unshielded	-
7	AC Cable	0.90	Unshielded	Unshielded	-
8	Signal Cable	0.10	Unshielded	Unshielded	*1)

*1) These items do not influence on RF characteristic.

SECTION 5: Conducted Emission

Test Procedure and conditions

EUT was placed on a urethane platform of nominal size, 1.0 m by 1.5 m, raised 0.8 m above the conducting ground plane. The rear of tabletop was located 40 cm to the vertical conducting plane. The rear of EUT, including peripherals aligned and flushed with rear of tabletop. All other surfaces of tabletop were at least 80cm from any other grounded conducting surface. EUT was located 80 cm from a Line Impedance Stabilization Network (LISN) / Artificial mains Network (AMN) and excess AC cable was bundled in center.

For the tests on EUT with other peripherals (as a whole system)

I/O cables that were connected to the peripherals were bundled in center. They were folded back and forth forming a bundle 30 cm to 40 cm long and were hanged at a 40 cm height to the ground plane. All unused 50ohm connectors of the LISN (AMN) were resistivity terminated in 50 ohm when not connected to the measuring equipment.

The AC Mains Terminal Continuous disturbance Voltage has been measured with the EUT in a Semi Anechoic Chamber. The EUT was connected to a LISN (AMN).

An overview sweep with peak detection has been performed.

The test results and limit are rounded off to one decimal place, so some differences might be observed.

Detector : QP and CISPR AV
Measurement range : 0.15 MHz - 30 MHz
Test data : APPENDIX
Test result : Pass

Figure 1: Test Setup

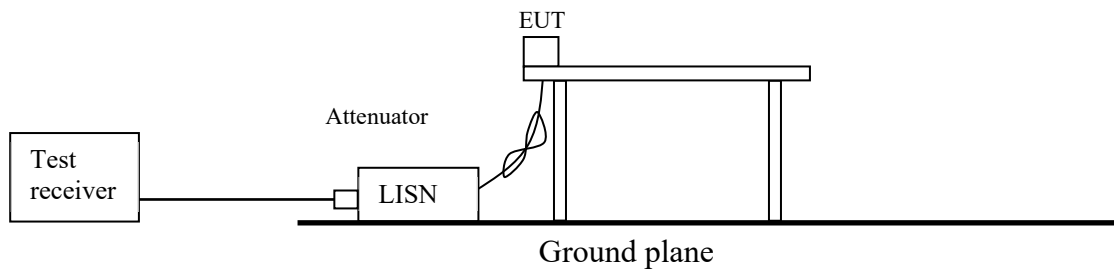

SECTION 6: Radiated Spurious Emission

Test Procedure

It was measured based on "8.5 and 8.6 of KDB 558074 D01 15.247 Meas Guidance v05r02".

[For below 1 GHz]

EUT was placed on a urethane platform of nominal size, 0.5 m by 1.0 m, raised 0.8 m above the conducting ground plane. The Radiated Electric Field Strength has been measured in a Semi Anechoic Chamber with a ground plane.

[For above 1 GHz]

EUT was placed on a urethane platform of nominal size, 0.5 m by 0.5 m, raised 1.5 m above the conducting ground plane. The Radiated Electric Field Strength has been measured in a Semi Anechoic Chamber with absorbent materials lined on a ground plane.

The height of the measuring antenna varied between 1 m and 4 m and EUT was rotated a full revolution in order to obtain the maximum value of the electric field strength.

Test antenna was aimed at the EUT for receiving the maximum signal and always kept within the illumination area of the 3 dB beamwidth of the antenna.

The measurements were performed for both vertical and horizontal antenna polarization with the Test Receiver, or the Spectrum Analyzer.

The measurements were made with the following detector function of the test receiver and the Spectrum analyzer (in linear mode).

The test was made with the detector (RBW/VBW) in the following table.

When using Spectrum analyzer, the test was made with adjusting span to zero by using peak hold.

Test Antennas are used as below;

Frequency	30 MHz to 200 MHz	200 MHz to 1 GHz	Above 1 GHz
Antenna Type	Biconical	Logperiodic	Horn

In any 100 kHz bandwidth outside the restricted band in which the spread spectrum intentional radiator is operating, the radio frequency power that is produced by the intentional radiator confirmed 20 dB below that in the 100 kHz bandwidth within the band that contains the highest level of the desired power, based on a radiated measurement.

20 dBc was applied to the frequency over the limit of FCC 15.209 / Table 4 of RSS-Gen 8.9(ISED) and outside the restricted band of FCC15.205 / Table 6 of RSS-Gen 8.10 (ISED).

Frequency	Below 1 GHz	Above 1 GHz		20 dBc
Instrument used	Test Receiver	Spectrum Analyzer		Spectrum Analyzer
Detector	QP	PK	AV *1)	PK
IF Bandwidth	BW 120 kHz	RBW: 1 MHz VBW: 3 MHz	<u>11.12.2.5.1</u> RBW: 1 MHz VBW: 3 MHz Detector: Power Averaging (RMS) Trace: 100 traces	RBW: 100 kHz VBW: 300 kHz

*1) Average Power Measurement was performed based on ANSI C63.10-2013.

UL Japan, Inc.

Ise EMC Lab.

4383-326 Asama-cho, Ise-shi, Mie-ken 516-0021 JAPAN

Telephone : +81 596 24 8999

Facsimile : +81 596 24 8124

Figure 2: Test Setup

Below 1 GHz

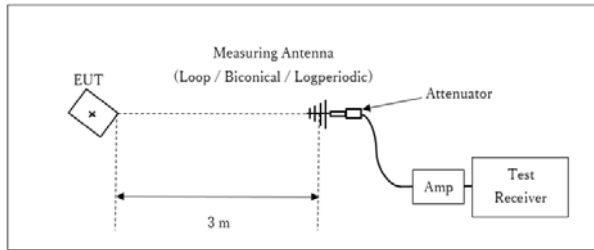

× : Center of turn table

Test Distance: 3 m

1 GHz - 10 GHz

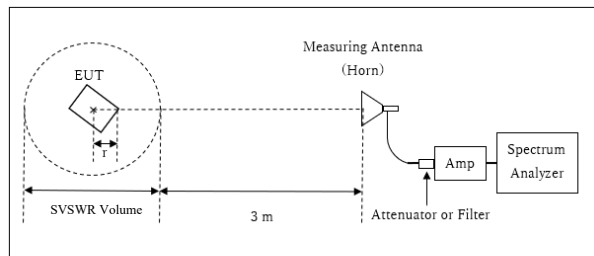

r : Radius of an outer periphery of EUT
 × : Center of turn table

Distance Factor: $20 \times \log(4.0 \text{ m} / 3.0 \text{ m}) = 2.5 \text{ dB}$
 * Test Distance: $(3 + \text{SVSWR Volume} / 2) - r = 4.0 \text{ m}$

SVSWR Volume : 2.0 m
 (SVSWR Volume has been calibrated based on CISPR 16-1-4.)
 r = 0.0 m

* The test was performed with r = 0.0 m since EUT is small and it was the rather conservative condition.

10 GHz - 26.5 GHz

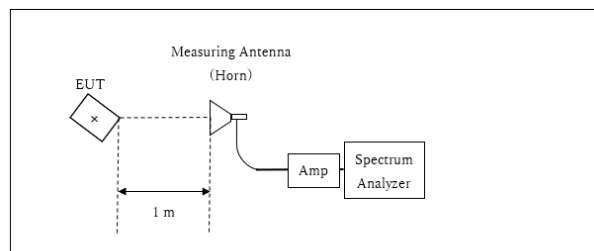

× : Center of turn table

Distance Factor: $20 \times \log(1.0 \text{ m} / 3.0 \text{ m}) = -9.5 \text{ dB}$
 *Test Distance: 1 m

- The carrier level and noise levels were confirmed at each position of X, Y and Z axes of EUT to see the position of maximum noise, and the test was made at the position that has the maximum noise.

The test results and limit are rounded off to one decimal place, so some differences might be observed.

Measurement range : 30 MHz - 26.5 GHz
Test data : APPENDIX
Test result : Pass

SECTION 7: Antenna Terminal Conducted Tests

Test Procedure

The tests were made with below setting connected to the antenna port.

Test	Span	RBW	VBW	Sweep time	Detector	Trace	Instrument used
6dB Bandwidth	3 MHz/5 MHz	100 kHz	300 kHz	Auto	Peak	Max Hold	Spectrum Analyzer
99% Occupied Bandwidth *1)	Enough width to display emission skirts	1 to 5 % of OBW	Three times of RBW	Auto	Peak	Max Hold	Spectrum Analyzer
Maximum Peak Output Power	-	-	-	Auto	Peak/Average *2)	-	Power Meter (Sensor: 50 MHz BW)
Peak Power Density	1.5 times the 6dB Bandwidth	3 kHz	10 kHz	Auto	Peak	Max Hold	Spectrum Analyzer *3) *4)
Conducted Spurious Emission *5) *6)	9kHz to 150kHz	200 Hz	620 Hz	Auto	Peak	Max Hold	Spectrum Analyzer
	150kHz to 30MHz	9.1 kHz	27 kHz				

*1) Peak hold was applied as Worst-case measurement.
*2) Reference data
*3) Section 11.10.2 Method PKPSD (peak PSD) of "ANSI C63.10-2013".
*4) The test was not performed at RBW:3 kHz however the measurement is to be performed with RBW:3kHz in the regulation, because, the measurement value with RBW:3 kHz is less than the value of RBW:30 kHz and the test data met the limit with RBW:30 kHz.
*5) In the frequency range below 30MHz, RBW was narrowed to separate the noise contents.
Then, wide-band noise near the limit was checked separately, however the noise was not detected as shown in the chart.
(9 kHz -150 kHz: RBW = 200 Hz, 150 kHz - 30 MHz: RBW = 9.1 kHz)
*6) The limits in CFR 47, Part 15, Subpart C, paragraph 15.209(a), are identical to those in RSS-Gen section 8.9, Table 6, since the measurements are performed in terms of magnetic field strength and converted to electric field strength levels (as reported in the table) using the free space impedance of 377 Ohms. For example, the measurement at frequency 9 kHz resulted in a level of 45.5 dBuV/m, which is equivalent to $45.5 - 51.5 = -6.0$ dBuA/m, which has the same margin, 3 dB, to the corresponding RSS-Gen Table 6 limit as it has to 15.209(a) limit.

The test results and limit are rounded off to two decimals place, so some differences might be observed.
The equipment and cables were not used for factor 0 dB of the data sheets.

Test data : APPENDIX
Test result : Pass

APPENDIX 1: Test data

Conducted Emission

Report No. 13477241H
Test place Ise EMC Lab. No.3 Semi Anechoic Chamber
Date November 4, 2020
Temperature / Humidity 23 deg. C / 36 % RH
Engineer Takeshi Hiyaji
Mode Tx BT LE 1M-PHY 2402 MHz

Limit : FCC_Part 15 Subpart C(15.207)

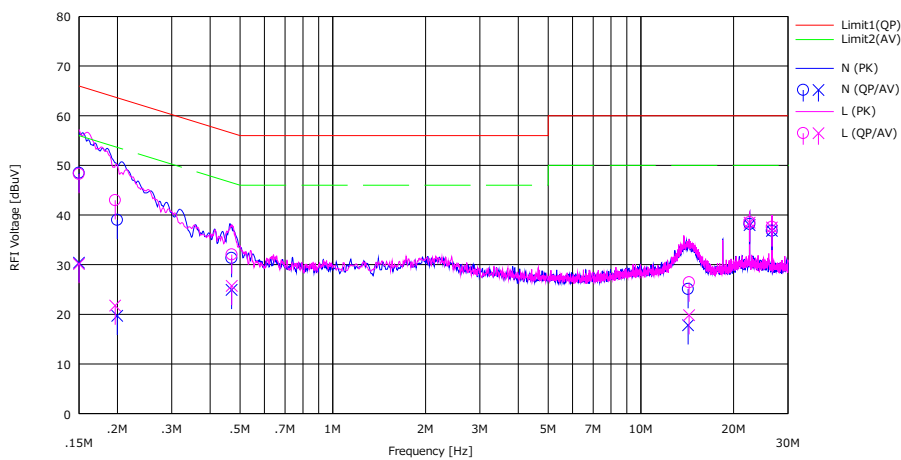

No.	Freq. [MHz]	Reading		LISN [dB]	LOSS [dB]	Results		Limit		Margin		Phase	Comment
		<QP> [dBuV]	<AV> [dBuV]			<QP> [dBuV]	<AV> [dBuV]	<QP> [dB]	<AV> [dB]				
1	0.15000	35.20	17.10	0.08	13.20	48.48	30.38	66.00	56.00	17.52	25.62	N	
2	0.19968	25.70	6.40	0.09	13.21	39.00	19.70	63.62	53.62	24.62	33.92	N	
3	0.46941	18.00	11.60	0.08	13.25	31.33	24.93	56.52	46.52	25.19	21.59	N	
4	14.22704	11.00	3.70	0.29	13.80	25.09	17.79	60.00	50.00	34.91	32.21	N	
5	22.52830	23.80	23.60	0.41	13.98	38.19	37.99	60.00	50.00	21.81	12.01	N	
6	26.62404	22.30	22.30	0.47	14.06	36.83	36.83	60.00	50.00	23.17	13.17	N	
7	0.15000	35.00	16.90	0.06	13.20	48.26	30.16	66.00	56.00	17.74	25.84	L	
8	0.19657	29.70	8.50	0.06	13.21	42.97	21.77	63.75	53.75	20.78	31.98	L	
9	0.46988	18.70	12.40	0.07	13.25	32.02	25.72	56.52	46.52	24.50	20.80	L	
10	14.33723	12.30	5.70	0.32	13.80	26.42	19.82	60.00	50.00	33.58	30.18	L	
11	22.52811	24.10	24.00	0.47	13.98	38.55	38.45	60.00	50.00	21.45	11.55	L	
12	26.62421	23.00	22.90	0.55	14.06	37.61	37.51	60.00	50.00	22.39	12.49	L	

CHART: WITH FACTOR Peak hold data. CALCULATION : RESULT = READING + LISN + LOSS (CABLE + ATT)
Except for the above table: adequate margin data below the limits.

Conducted Emission

Report No.	13477241H
Test place	Ise EMC Lab. No.3 Semi Anechoic Chamber
Date	November 4, 2020
Temperature / Humidity	23 deg. C / 36 % RH
Engineer	Takeshi Hiyaji
Mode	Tx BT LE 1M-PHY

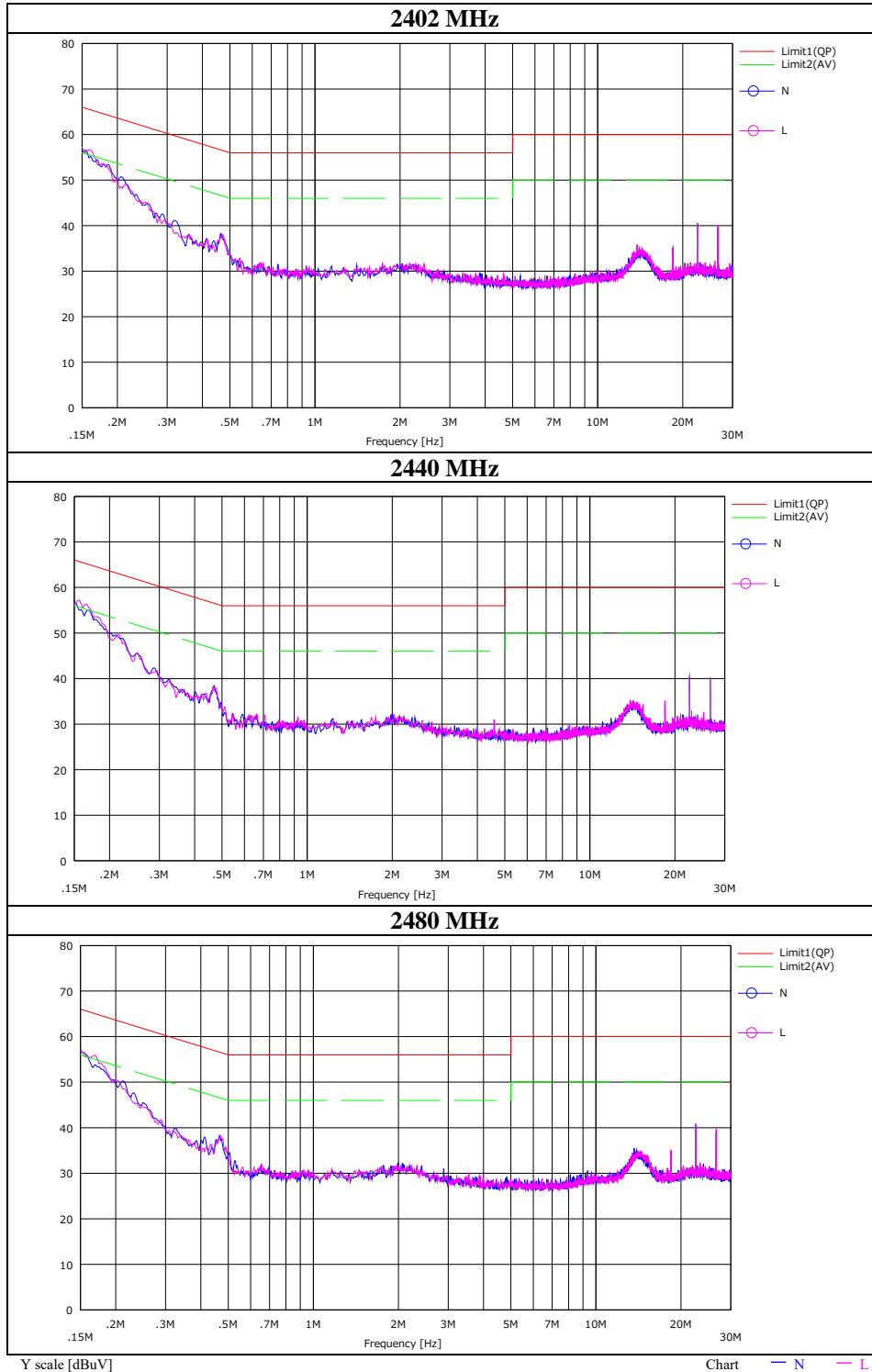

UL Japan, Inc.

Ise EMC Lab.

4383-326 Asama-cho, Ise-shi, Mie-ken 516-0021 JAPAN

Telephone : +81 596 24 8999

Facsimile : +81 596 24 8124

Conducted Emission

Report No. 13477241H
Test place Ise EMC Lab. No.3 Semi Anechoic Chamber
Date November 4, 2020
Temperature / Humidity 23 deg. C / 36 % RH
Engineer Takeshi Hiyaji
Mode Tx BT LE 2M-PHY 2402 MHz

Limit : FCC_Part 15 Subpart C(15.207)

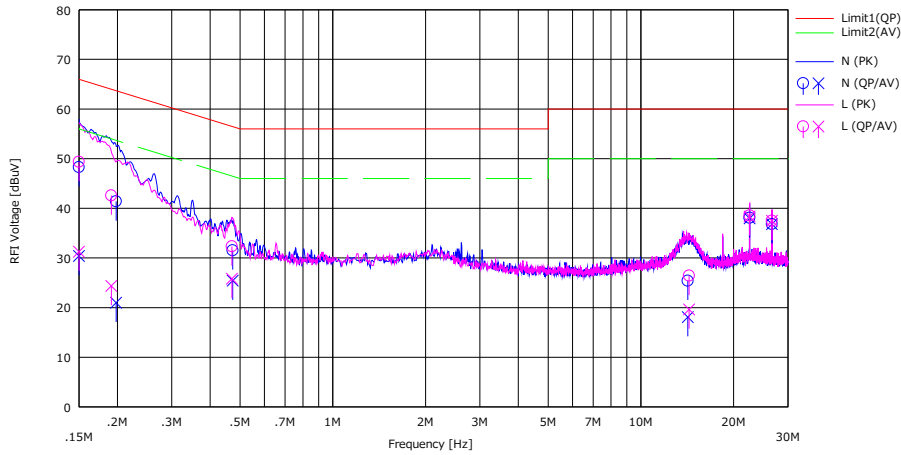

No.	Freq. [MHz]	Reading		LISN [dB]	LOSS [dB]	Results		Limit		Margin		Phase	Comment
		<QP> [dBuV]	<AV> [dBuV]			<QP> [dBuV]	<AV> [dBuV]	<QP> [dBuV]	<AV> [dBuV]	<QP> [dB]	<AV> [dB]		
1	0.15000	35.00	17.10	0.08	13.20	48.28	30.38	66.00	56.00	17.72	25.62	N	
2	0.19808	28.10	7.70	0.09	13.21	41.40	21.00	63.69	53.69	22.29	32.69	N	
3	0.47325	18.20	12.10	0.08	13.25	31.53	25.43	56.46	46.46	24.93	21.03	N	
4	14.18890	11.30	4.00	0.29	13.80	25.39	18.09	60.00	50.00	34.61	31.91	N	
5	22.52810	23.70	23.60	0.41	13.98	38.09	37.99	60.00	50.00	21.91	12.01	N	
6	26.62420	22.30	22.30	0.47	14.06	36.83	36.83	60.00	50.00	23.17	13.17	N	
7	0.15000	36.10	18.00	0.06	13.20	49.36	31.26	66.00	56.00	16.64	24.74	L	
8	0.19108	29.30	11.10	0.06	13.21	42.57	24.37	63.99	53.99	21.42	29.62	L	
9	0.47048	19.00	12.50	0.07	13.25	32.32	25.82	56.51	46.51	24.19	20.69	L	
10	14.33452	12.30	5.50	0.32	13.80	26.42	19.62	60.00	50.00	33.58	30.38	L	
11	22.52820	24.10	23.90	0.47	13.98	38.55	38.35	60.00	50.00	21.45	11.65	L	
12	26.62419	22.90	22.90	0.55	14.06	37.51	37.51	60.00	50.00	22.49	12.49	L	

CHART: WITH FACTOR Peak hold data. CALCULATION : RESULT = READING + LISN + LOSS (CABLE + ATT)
Except for the above table: adequate margin data below the limits.

Conducted Emission

Report No. 13477241H
Test place Ise EMC Lab. No.3 Semi Anechoic Chamber
Date November 4, 2020
Temperature / Humidity 23 deg. C / 36 % RH
Engineer Takeshi Hiyaji
Mode Tx BT LE 2M-PHY

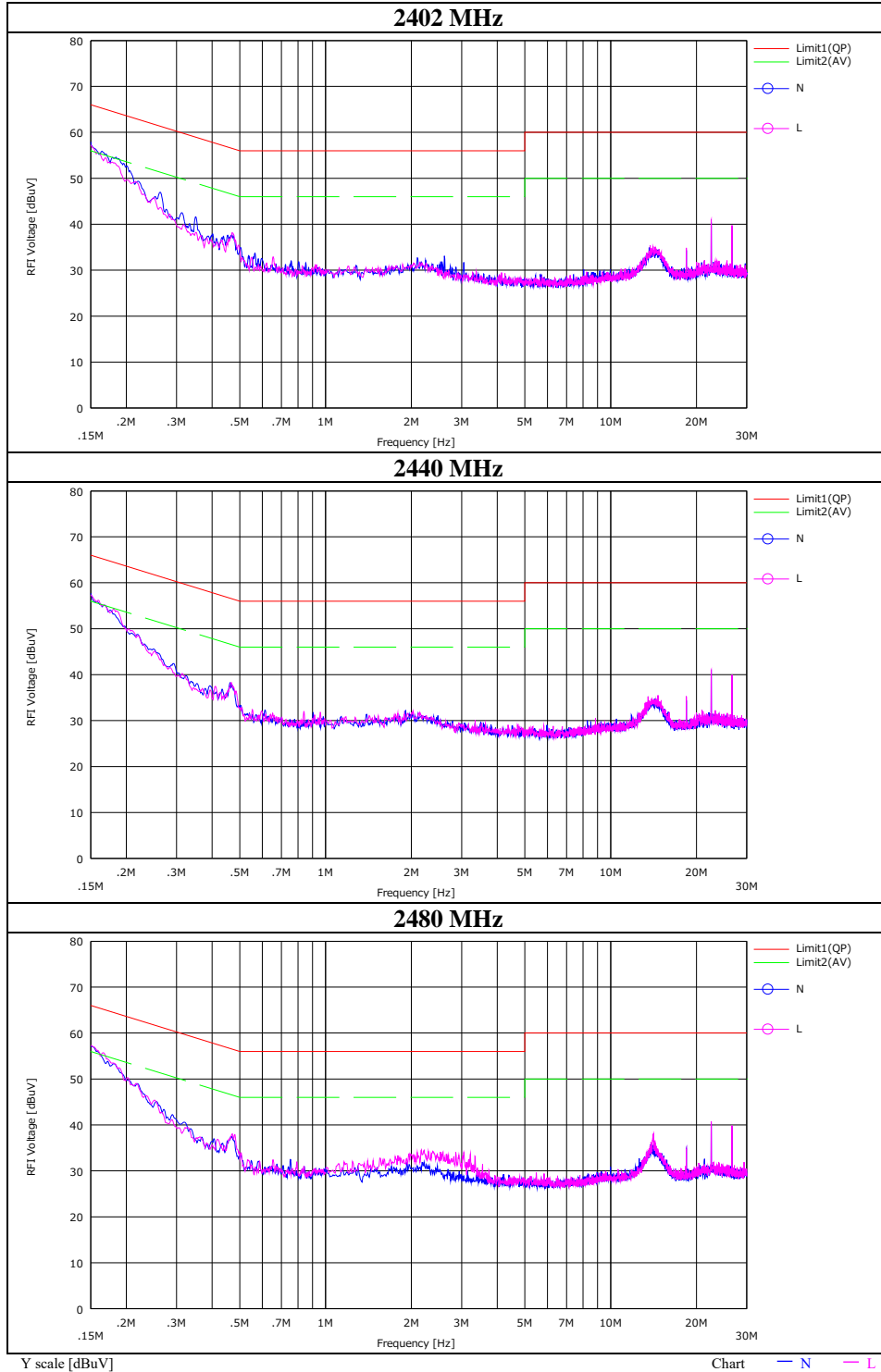

UL Japan, Inc.

Ise EMC Lab.

4383-326 Asama-cho, Ise-shi, Mie-ken 516-0021 JAPAN

Telephone : +81 596 24 8999

Facsimile : +81 596 24 8124

6 dB Bandwidth and 99 % Occupied Bandwidth

Report No. 13477241H
Test place Ise EMC Lab. No.6 Shielded Room
Date November 2, 2020
Temperature / Humidity 21 deg. C / 52 % RH
Engineer Yuta Moriya
Mode Tx

Mode	Frequency [MHz]	99% Occupied Bandwidth [kHz]	6dB Bandwidth [MHz]	Limit for 6dB Bandwidth [MHz]
1M-PHY	2402	1036.7	0.6688	> 0.5000
	2440	1035.5	0.6778	> 0.5000
	2480	1036.9	0.6801	> 0.5000
2M-PHY	2402	2081.0	1.1720	> 0.5000
	2440	2090.1	1.1760	> 0.5000
	2480	2086.3	1.1750	> 0.5000

99% Occupied Bandwidth

BT LE 1M-PHY
2402 MHz

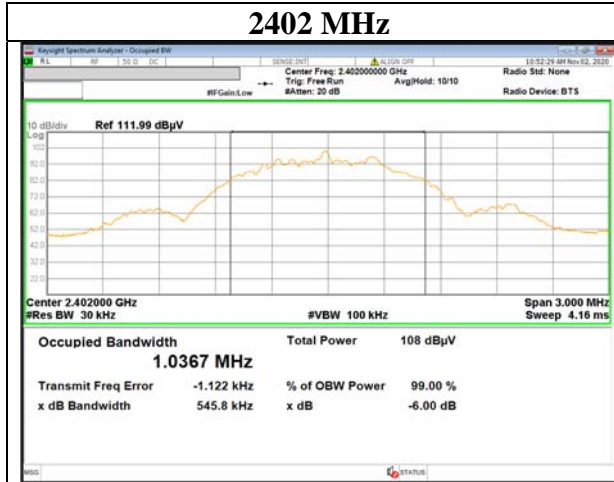

BT LE 2M-PHY
2402 MHz

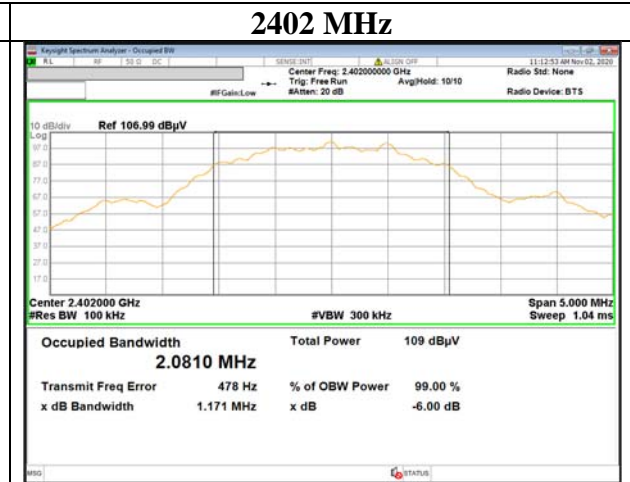

2440 MHz

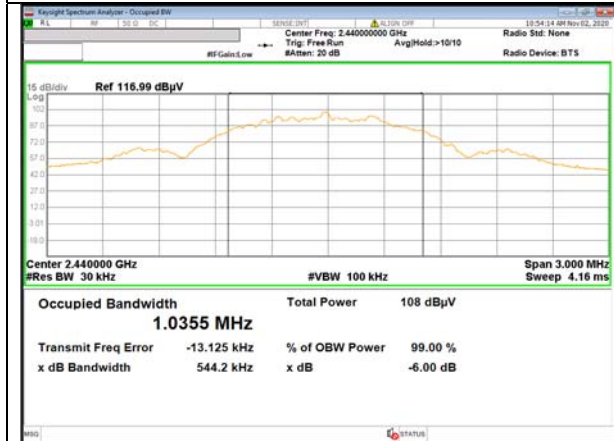

2440 MHz

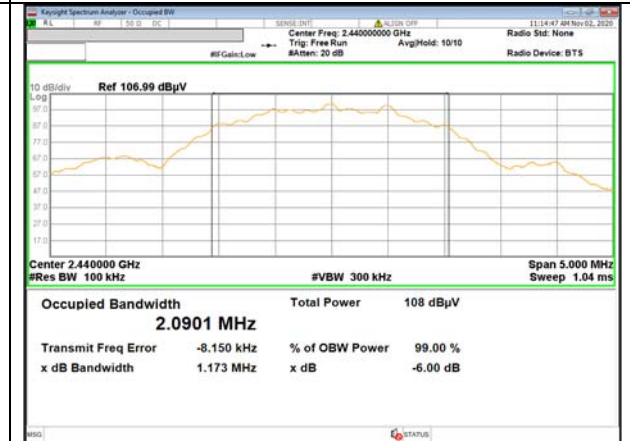

2480 MHz



2480 MHz

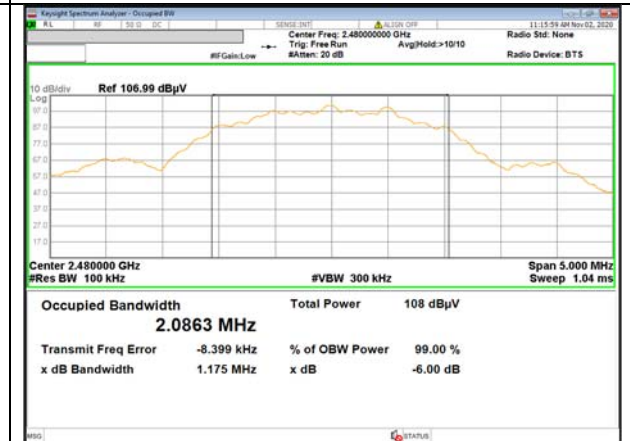

6dB Bandwidth

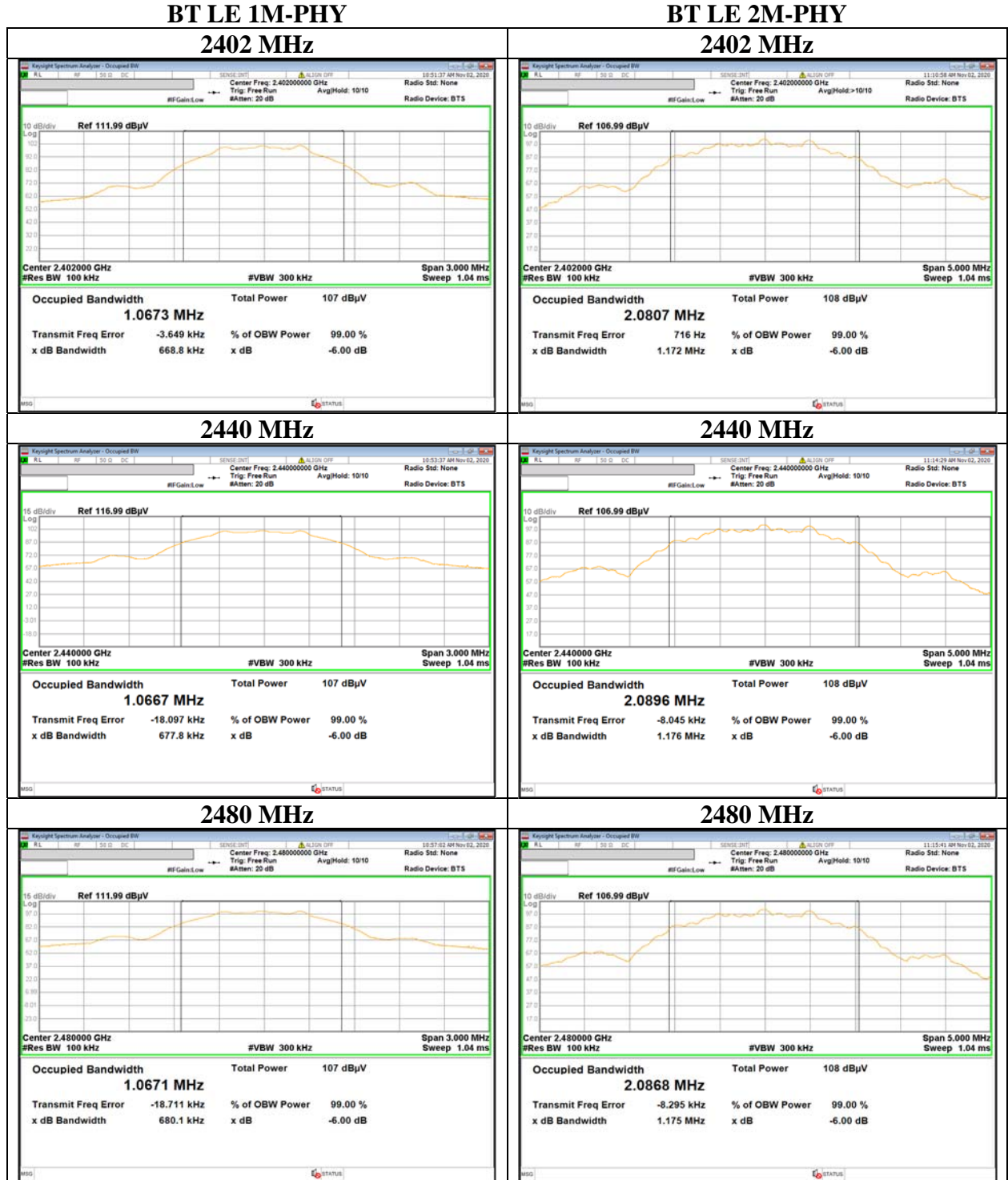

Maximum Peak Output Power

Report No. 13477241H
Test place Ise EMC Lab. No.6 Shielded Room
Date November 2, 2020
Temperature / Humidity 21 deg. C / 52 % RH
Engineer Yuta Moriya
Mode Tx BT LE

1M-PHY				Conducted Power						e.i.r.p. for RSS-247				
Freq. [MHz]	Reading [dBm]	Cable Loss [dB]	Atten. Loss [dB]	Result		Limit		Margin [dB]	Antenna Gain [dBi]	Result		Limit		Margin [dB]
				[dBm]	[mW]	[dBm]	[mW]			[dBm]	[mW]	[dBm]	[mW]	
2402	-5.06	0.35	10.10	5.39	3.46	30.00	1000	24.61	1.51	6.90	4.90	36.02	4000	29.12
2440	-5.49	0.35	10.10	4.96	3.13	30.00	1000	25.04	1.51	6.47	4.44	36.02	4000	29.55
2480	-5.52	0.35	10.10	4.93	3.11	30.00	1000	25.07	1.51	6.44	4.41	36.02	4000	29.58

2M-PHY				Conducted Power						e.i.r.p. for RSS-247				
Freq. [MHz]	Reading [dBm]	Cable Loss [dB]	Atten. Loss [dB]	Result		Limit		Margin [dB]	Antenna Gain [dBi]	Result		Limit		Margin [dB]
				[dBm]	[mW]	[dBm]	[mW]			[dBm]	[mW]	[dBm]	[mW]	
2402	-4.52	0.35	10.10	5.93	3.92	30.00	1000	24.07	1.51	7.44	5.55	36.02	4000	28.58
2440	-4.88	0.35	10.10	5.57	3.61	30.00	1000	24.43	1.51	7.08	5.11	36.02	4000	28.94
2480	-4.91	0.35	10.10	5.54	3.58	30.00	1000	24.46	1.51	7.05	5.07	36.02	4000	28.97

Sample Calculation:

Result = Reading + Cable Loss (including the cable(s) customer supplied) + Attenuator Loss

e.i.r.p. Result = Conducted Power Result + Antenna Gain

*The equipment and cables were not used for factor 0 dB of the data sheets.

Average Output Power
(Reference data for RF Exposure)

Report No. 13477241H
Test place Ise EMC Lab. No.6 Shielded Room
Date November 2, 2020
Temperature / Humidity 21 deg. C / 52 % RH
Engineer Yuta Moriya
Mode Tx BT LE

1M-PHY

Freq. [MHz]	Reading [dBm]	Cable Loss [dB]	Atten. Loss [dB]	Result (Time average)		Duty factor [dB]	Result (Burst power average)	
				[dBm]	[mW]		[dBm]	[mW]
2402	-6.24	0.35	10.10	4.21	2.64	0.63	4.84	3.05
2440	-6.67	0.35	10.10	3.78	2.39	0.63	4.41	2.76
2480	-6.69	0.35	10.10	3.76	2.38	0.63	4.39	2.75

2M-PHY

Freq. [MHz]	Reading [dBm]	Cable Loss [dB]	Atten. Loss [dB]	Result (Time average)		Duty factor [dB]	Result (Burst power average)	
				[dBm]	[mW]		[dBm]	[mW]
2402	-5.75	0.35	10.10	4.70	2.95	0.53	5.23	3.33
2440	-6.16	0.35	10.10	4.29	2.69	0.53	4.82	3.03
2480	-6.17	0.35	10.10	4.28	2.68	0.53	4.81	3.03

Sample Calculation:

Result (Time average) = Reading + Cable Loss (including the cable(s) customer supplied) + Attenuator Loss

Result (Burst power average) = Time average + Duty factor

*The equipment and cables were not used for factor 0 dB of the data sheets.

Burst rate confirmation

Report No. 13477241H
 Test place Ise EMC Lab. No.3 Semi Anechoic Chamber
 Date November 2, 2020
 Temperature / Humidity 22 deg. C / 40 % RH
 Engineer Yuta Moriya
 Mode Tx

BT LE 1M-PHY

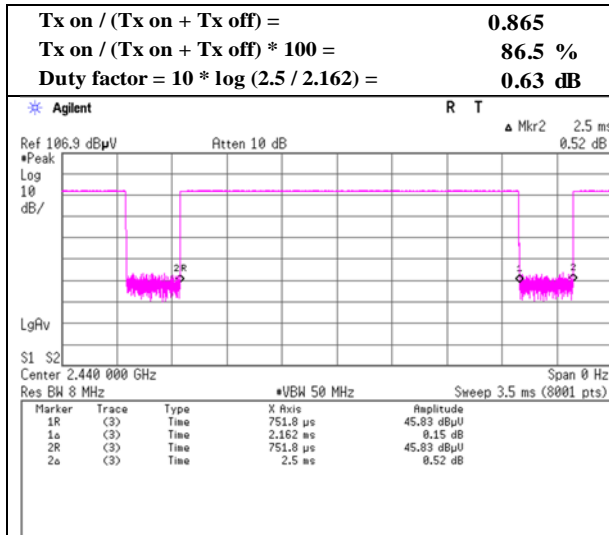

BT LE 2M-PHY

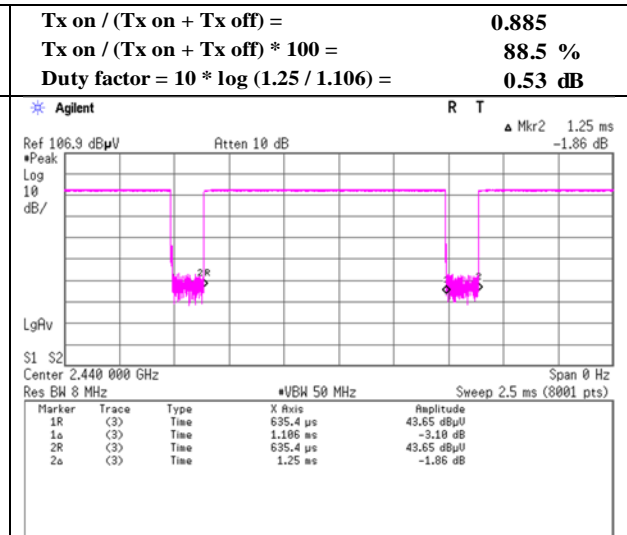

* Since the burst rate is not different between the channels, the data has been obtained on the representative channel.

Radiated Spurious Emission

Report No.	13477241H	
Test place	Ise EMC Lab.	
Semi Anechoic Chamber	No.3	No.3
Date	November 2, 2020 (Day)	November 2, 2020 (Night)
Temperature / Humidity	22 deg. C / 40 % RH	23 deg. C / 50 % RH
Engineer	Yuta Moriya	Takeshi Hiyaji
	(1 GHz - 10 GHz)	(10 GHz - 26.5 GHz)
Mode	Tx BT LE 1M-PHY 2402 MHz	
		No.3
		November 3, 2020
		23 deg. C / 38 % RH
		Takeshi Hiyaji
		(Below 1 GHz)

Polarity	Frequency [MHz]	Detector	Reading [dBuV]	Ant.Fac. [dB/m]	Loss [dB]	Gain [dB]	Duty Factor [dB]	Result [dBuV/m]	Limit [dBuV/m]	Margin [dB]	Remark
Hori.	55.300	QP	36.8	9.2	7.6	32.2	-	21.4	40.0	18.6	
Hori.	84.000	QP	37.1	7.6	8.0	32.2	-	20.6	40.0	19.5	
Hori.	108.000	QP	26.0	11.2	8.3	32.1	-	13.3	43.5	30.2	
Hori.	144.000	QP	35.5	14.9	8.7	32.1	-	27.0	43.5	16.5	
Hori.	276.000	QP	44.6	13.2	9.9	32.0	-	35.7	46.0	10.3	
Hori.	480.000	QP	40.6	17.2	11.3	32.0	-	37.1	46.0	8.9	
Hori.	2390.000	PK	42.4	27.5	5.6	32.7	-	42.7	73.9	31.2	
Hori.	4804.000	PK	42.0	31.7	7.7	31.7	-	49.7	73.9	24.2	
Hori.	7206.000	PK	42.2	36.1	9.1	32.6	-	54.7	73.9	19.2	Floor noise
Hori.	9608.000	PK	43.2	38.7	9.5	33.3	-	58.1	73.9	15.8	Floor noise
Hori.	2390.000	AV	34.2	27.5	5.6	32.7	0.6	35.3	53.9	18.7	*1)
Hori.	4804.000	AV	35.6	31.7	7.7	31.7	0.6	44.0	53.9	10.0	
Hori.	7206.000	AV	34.6	36.1	9.1	32.6	-	47.2	53.9	6.7	Floor noise
Hori.	9608.000	AV	32.5	38.7	9.5	33.3	-	47.4	53.9	6.5	Floor noise
Vert.	55.300	QP	41.0	9.2	7.6	32.2	-	25.6	40.0	14.4	
Vert.	84.000	QP	45.7	7.6	8.0	32.2	-	29.2	40.0	10.9	
Vert.	108.000	QP	39.5	11.2	8.3	32.1	-	26.8	43.5	16.7	
Vert.	144.000	QP	35.5	14.9	8.7	32.1	-	27.0	43.5	16.5	
Vert.	276.000	QP	45.9	13.2	9.9	32.0	-	37.0	46.0	9.0	
Vert.	480.000	QP	40.2	17.2	11.3	32.0	-	36.7	46.0	9.3	
Vert.	2390.000	PK	42.3	27.5	5.6	32.7	-	42.7	73.9	31.2	
Vert.	4804.000	PK	42.6	31.7	7.7	31.7	-	50.3	73.9	23.6	
Vert.	7206.000	PK	42.3	36.1	9.1	32.6	-	54.9	73.9	19.0	Floor noise
Vert.	9608.000	PK	43.0	38.7	9.5	33.3	-	57.9	73.9	16.0	Floor noise
Vert.	2390.000	AV	34.6	27.5	5.6	32.7	0.6	35.6	53.9	18.3	*1)
Vert.	4804.000	AV	35.6	31.7	7.7	31.7	0.6	44.0	53.9	9.9	
Vert.	7206.000	AV	34.6	36.1	9.1	32.6	-	47.2	53.9	6.7	Floor noise
Vert.	9608.000	AV	32.6	38.7	9.5	33.3	-	47.5	53.9	6.4	Floor noise

Result = Reading + Ant Factor + Loss (Cable+Attenuator+Filter+Distance factor(above 1 GHz)) - Gain(Amplifier) + Duty factor

*Other frequency noises omitted in this report were not seen or had enough margin (more than 20 dB).

Distance factor: 1 GHz - 10 GHz 20log(4.0 m / 3.0 m) = 2.5 dB
10 GHz - 26.5 GHz 20log(1.0 m / 3.0 m) = -9.5 dB

*1) Not Out of Band emission(Leakage Power)

20dBc Data Sheet

Polarity	Frequency [MHz]	Detector	Reading [dBuV]	Ant Factor [dB/m]	Loss [dB]	Gain [dB]	Result [dBuV/m]	Limit [dBuV/m]	Margin [dB]	Remark
Hori.	2402.000	PK	100.5	27.5	5.6	32.7	100.9	-	-	Carrier
Hori.	2399.242	PK	55.8	27.5	5.6	32.7	56.2	80.9	24.7	
Hori.	2400.000	PK	50.5	27.5	5.6	32.7	50.9	80.9	30.0	
Vert.	2402.000	PK	101.7	27.5	5.6	32.7	102.1	-	-	Carrier
Vert.	2399.242	PK	57.4	27.5	5.6	32.7	57.8	82.1	24.4	
Vert.	2400.000	PK	52.0	27.5	5.6	32.7	52.4	82.1	29.7	

Result = Reading + Ant Factor + Loss (Cable+Attenuator+Filter+Distance factor(above 1 GHz)) - Gain(Amplifier)

UL Japan, Inc.

Ise EMC Lab.

4383-326 Asama-cho, Ise-shi, Mie-ken 516-0021 JAPAN

Telephone : +81 596 24 8999

Facsimile : +81 596 24 8124

Radiated Spurious Emission
(Reference Plot for band-edge)

Report No. 13477241H
Test place Ise EMC Lab.
Semi Anechoic Chamber No.3
Date November 2, 2020
Temperature / Humidity 22 deg. C / 40 % RH
Engineer Yuta Moriya
(1 GHz - 10 GHz)
Mode Tx BT LE 1M-PHY 2402 MHz

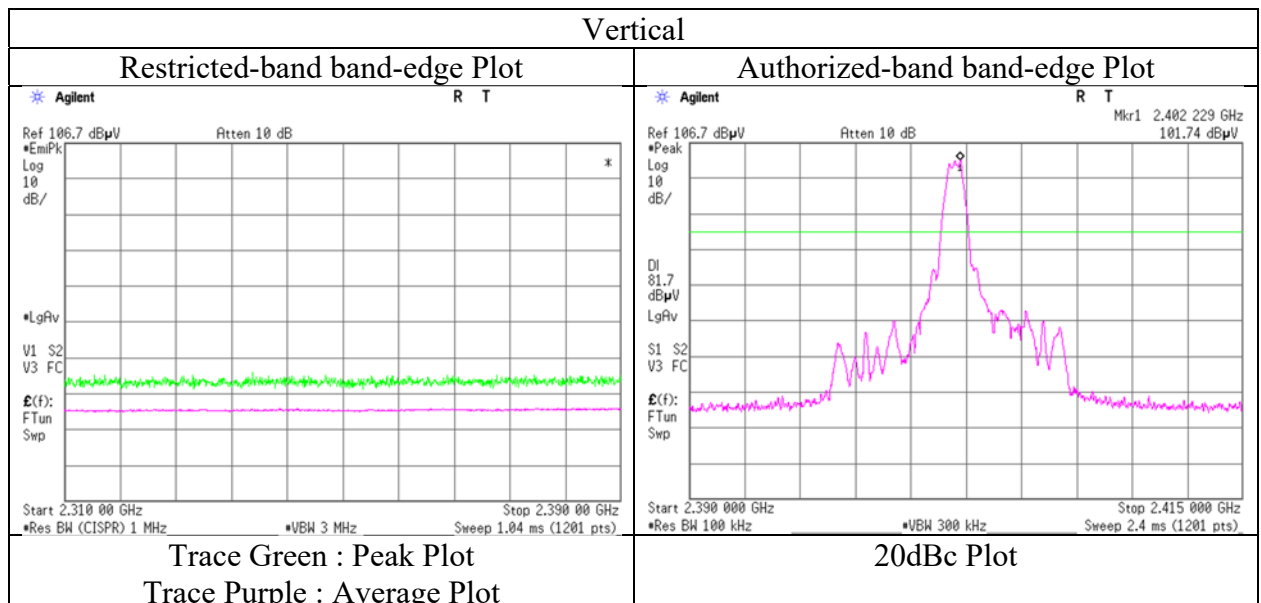
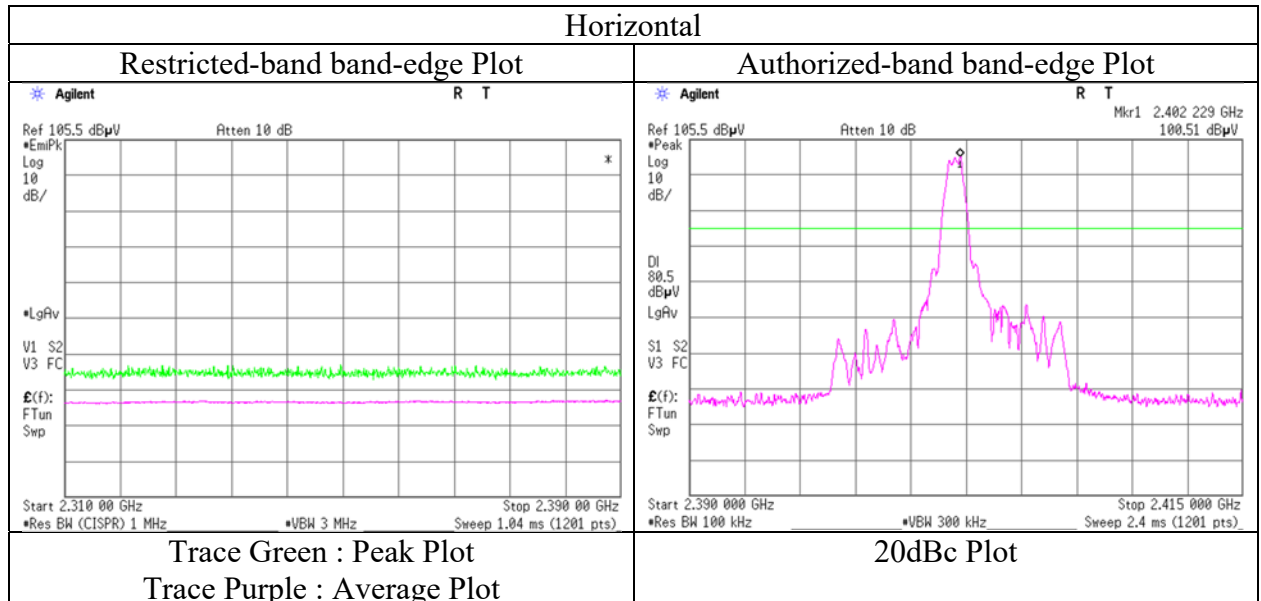

* The measurement was conducted for a sufficiently long enough time to detect any possible spurious emissions. Final result of restricted band edge was shown in tabular data.

Radiated Spurious Emission

Report No. 13477241H
Test place Ise EMC Lab.
Semi Anechoic Chamber No.3 No.3 No.3
Date November 2, 2020 (Day) November 2, 2020 (Night) November 3, 2020
Temperature / Humidity 22 deg. C / 40 % RH 23 deg. C / 50 % RH 23 deg. C / 38 % RH
Engineer Yuta Moriya Takeshi Hiyaji Takeshi Hiyaji
(1 GHz - 10 GHz) (10 GHz - 26.5 GHz) (Below 1 GHz)
Mode Tx BT LE 1M-PHY 2440 MHz

Polarity	Frequency [MHz]	Detector	Reading [dBuV]	Ant.Fac. [dB/m]	Loss [dB]	Gain [dB]	Duty Factor [dB]	Result [dBuV/m]	Limit [dBuV/m]	Margin [dB]	Remark
Hori.	55.300	QP	37.2	9.2	7.6	32.2	-	21.8	40.0	18.2	
Hori.	84.000	QP	39.8	7.6	8.0	32.2	-	23.3	40.0	16.8	
Hori.	108.000	QP	26.2	11.2	8.3	32.1	-	13.5	43.5	30.0	
Hori.	144.000	QP	34.6	14.9	8.7	32.1	-	26.1	43.5	17.4	
Hori.	276.000	QP	44.5	13.2	9.9	32.0	-	35.6	46.0	10.4	
Hori.	480.000	QP	41.2	17.2	11.3	32.0	-	37.7	46.0	8.3	
Hori.	4880.000	PK	41.4	31.5	7.7	31.6	-	48.9	73.9	25.0	
Hori.	7320.000	PK	41.8	36.2	9.1	32.6	-	54.5	73.9	19.5	Floor noise
Hori.	9760.000	PK	42.4	39.0	9.6	33.4	-	57.6	73.9	16.3	Floor noise
Hori.	4880.000	AV	34.0	31.5	7.7	31.6	0.6	42.2	53.9	11.7	
Hori.	7320.000	AV	34.4	36.2	9.1	32.6	-	47.0	53.9	6.9	Floor noise
Hori.	9760.000	AV	32.4	39.0	9.6	33.4	-	47.6	53.9	6.3	Floor noise
Vert.	55.300	QP	43.8	9.2	7.6	32.2	-	28.4	40.0	11.6	
Vert.	84.000	QP	46.4	7.6	8.0	32.2	-	29.9	40.0	10.2	
Vert.	108.000	QP	38.2	11.2	8.3	32.1	-	25.5	43.5	18.0	
Vert.	144.000	QP	36.0	14.9	8.7	32.1	-	27.5	43.5	16.0	
Vert.	276.000	QP	46.3	13.2	9.9	32.0	-	37.4	46.0	8.6	
Vert.	480.000	QP	40.8	17.2	11.3	32.0	-	37.3	46.0	8.7	
Vert.	4880.000	PK	41.1	31.5	7.7	31.6	-	48.6	73.9	25.3	
Vert.	7320.000	PK	41.8	36.2	9.1	32.6	-	54.4	73.9	19.5	Floor noise
Vert.	9760.000	PK	42.6	39.0	9.6	33.4	-	57.8	73.9	16.1	Floor noise
Vert.	4880.000	AV	34.6	31.5	7.7	31.6	0.6	42.8	53.9	11.1	
Vert.	7320.000	AV	34.4	36.2	9.1	32.6	-	47.0	53.9	6.9	Floor noise
Vert.	9760.000	AV	32.4	39.0	9.6	33.4	-	47.6	53.9	6.3	Floor noise

Result = Reading + Ant Factor + Loss (Cable+Attenuator+Filter+Distance factor(above 1 GHz)) - Gain(Amplifier) + Duty factor
*Other frequency noises omitted in this report were not seen or had enough margin (more than 20 dB).

Distance factor: 1 GHz - 10 GHz $20\log(4.0\text{ m} / 3.0\text{ m}) = 2.5\text{ dB}$
10 GHz - 26.5 GHz $20\log(1.0\text{ m} / 3.0\text{ m}) = -9.5\text{ dB}$

Radiated Spurious Emission

Report No. 13477241H
Test place Ise EMC Lab.
Semi Anechoic Chamber No.3 No.3 No.3
Date November 2, 2020 (Day) November 2, 2020 (Night) November 3, 2020
Temperature / Humidity 22 deg. C / 40 % RH 23 deg. C / 50 % RH 23 deg. C / 38 % RH
Engineer Yuta Moriya Takeshi Hiyaji Takeshi Hiyaji
(1 GHz - 10 GHz) (10 GHz - 26.5 GHz) (Below 1 GHz)
Mode Tx BT LE 1M-PHY 2480 MHz

Polarity	Frequency [MHz]	Detector	Reading [dBuV]	Ant.Fac. [dB/m]	Loss [dB]	Gain [dB]	Duty Factor [dB]	Result [dBuV/m]	Limit [dBuV/m]	Margin [dB]	Remark
Hori.	55.300	QP	36.6	9.2	7.6	32.2	-	21.2	40.0	18.8	
Hori.	84.000	QP	38.8	7.6	8.0	32.2	-	22.3	40.0	17.8	
Hori.	108.000	QP	25.8	11.2	8.3	32.1	-	13.1	43.5	30.4	
Hori.	144.000	QP	34.2	14.9	8.7	32.1	-	25.7	43.5	17.8	
Hori.	276.000	QP	42.8	13.2	9.9	32.0	-	33.9	46.0	12.1	
Hori.	480.000	QP	41.4	17.2	11.3	32.0	-	37.9	46.0	8.1	
Hori.	2483.500	PK	53.0	27.3	5.7	32.7	-	53.3	73.9	20.6	
Hori.	4960.000	PK	42.6	31.5	7.7	31.6	-	50.2	73.9	23.7	
Hori.	7440.000	PK	41.7	36.3	9.1	32.7	-	54.3	73.9	19.6	Floor noise
Hori.	9920.000	PK	43.2	38.8	9.6	33.5	-	58.1	73.9	15.8	Floor noise
Hori.	2483.500	AV	46.9	27.3	5.7	32.7	0.6	47.8	53.9	6.1	*1)
Hori.	4960.000	AV	35.5	31.5	7.7	31.6	0.6	43.7	53.9	10.2	
Hori.	7440.000	AV	34.0	36.3	9.1	32.7	-	46.7	53.9	7.2	Floor noise
Hori.	9920.000	AV	32.5	38.8	9.6	33.5	-	47.4	53.9	6.5	Floor noise
Vert.	55.300	QP	42.8	9.2	7.6	32.2	-	27.4	40.0	12.6	
Vert.	84.000	QP	45.8	7.6	8.0	32.2	-	29.3	40.0	10.8	
Vert.	108.000	QP	37.6	11.2	8.3	32.1	-	24.9	43.5	18.6	
Vert.	144.000	QP	35.8	14.9	8.7	32.1	-	27.3	43.5	16.2	
Vert.	276.000	QP	44.7	13.2	9.9	32.0	-	35.8	46.0	10.2	
Vert.	480.000	QP	40.6	17.2	11.3	32.0	-	37.1	46.0	8.9	
Vert.	2483.500	PK	53.2	27.3	5.7	32.7	-	53.5	73.9	20.4	
Vert.	4960.000	PK	42.8	31.5	7.7	31.6	-	50.3	73.9	23.6	
Vert.	7440.000	PK	41.5	36.3	9.1	32.7	-	54.1	73.9	19.8	Floor noise
Vert.	9920.000	PK	43.2	38.8	9.6	33.5	-	58.1	73.9	15.8	Floor noise
Vert.	2483.500	AV	46.9	27.3	5.7	32.7	0.6	47.8	53.9	6.1	*1)
Vert.	4960.000	AV	36.5	31.5	7.7	31.6	0.6	44.7	53.9	9.2	
Vert.	7440.000	AV	34.0	36.3	9.1	32.7	-	46.7	53.9	7.2	Floor noise
Vert.	9920.000	AV	32.4	38.8	9.6	33.5	-	47.3	53.9	6.6	Floor noise

Result = Reading + Ant Factor + Loss (Cable+Attenuator+Filter+Distance factor(above 1 GHz)) - Gain(Amplifier) + Duty factor

*Other frequency noises omitted in this report were not seen or had enough margin (more than 20 dB).

Distance factor: 1 GHz - 10 GHz $20\log(4.0\text{ m} / 3.0\text{ m}) = 2.5\text{ dB}$
10 GHz - 26.5 GHz $20\log(1.0\text{ m} / 3.0\text{ m}) = -9.5\text{ dB}$

*1) Not Out of Band emission(Leakage Power)

Radiated Spurious Emission
(Reference Plot for band-edge)

Report No. 13477241H
Test place Ise EMC Lab.
Semi Anechoic Chamber No.3
Date November 2, 2020
Temperature / Humidity 22 deg. C / 40 % RH
Engineer Yuta Moriya
(1 GHz - 10 GHz)
Mode Tx BT LE 1M-PHY 2480 MHz

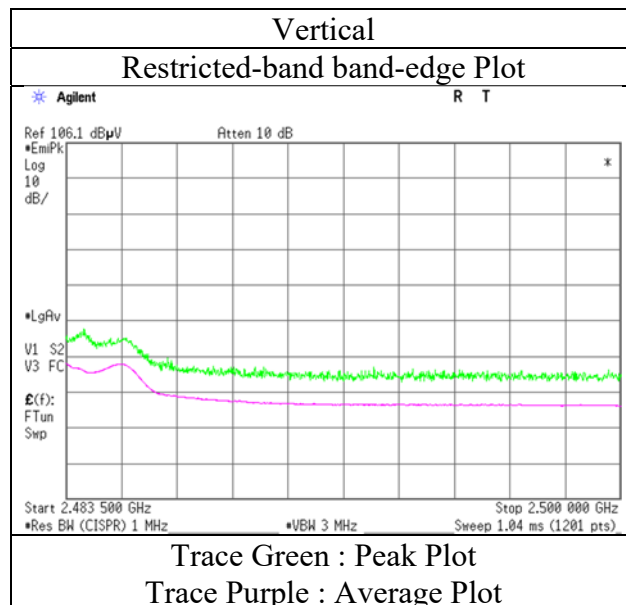
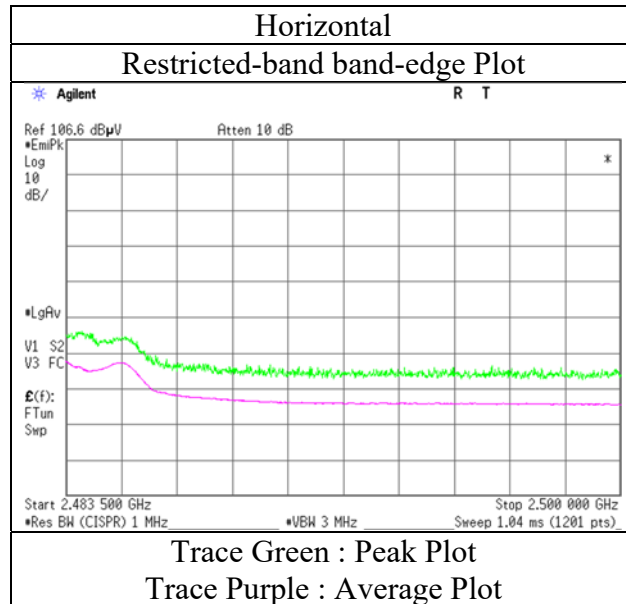

* The measurement was conducted for a sufficiently long enough time to detect any possible spurious emissions. Final result of restricted band edge was shown in tabular data.

Radiated Spurious Emission

Report No. 13477241H
Test place Ise EMC Lab.
Semi Anechoic Chamber No.3 No.3
Date November 2, 2020 November 3, 2020
Temperature / Humidity 23 deg. C / 50 % RH 23 deg. C / 38 % RH
Engineer Takeshi Hiyaji Takeshi Hiyaji
(Above 1 GHz) (Below 1 GHz)
Mode Tx BT LE 2M-PHY 2402 MHz

Polarity	Frequency [MHz]	Detector	Reading [dBuV]	Ant.Fac. [dB/m]	Loss [dB]	Gain [dB]	Duty Factor [dB]	Result [dBuV/m]	Limit [dBuV/m]	Margin [dB]	Remark
Hori.	55.300	QP	38.2	9.2	7.6	32.2	-	22.8	40.0	17.2	
Hori.	84.000	QP	39.4	7.6	8.0	32.2	-	22.9	40.0	17.2	
Hori.	108.000	QP	26.3	11.2	8.3	32.1	-	13.6	43.5	29.9	
Hori.	144.000	QP	35.1	14.9	8.7	32.1	-	26.6	43.5	16.9	
Hori.	276.000	QP	43.5	13.2	9.9	32.0	-	34.6	46.0	11.4	
Hori.	480.000	QP	40.5	17.2	11.3	32.0	-	37.0	46.0	9.0	
Hori.	2390.000	PK	42.7	27.5	5.6	32.7	-	43.0	73.9	30.9	
Hori.	4804.000	PK	41.2	31.7	7.7	31.7	-	49.0	73.9	24.9	
Hori.	7206.000	PK	42.2	36.1	9.1	32.6	-	54.8	73.9	19.1	Floor noise
Hori.	9608.000	PK	42.9	38.7	9.5	33.3	-	57.8	73.9	16.1	Floor noise
Hori.	2390.000	AV	34.6	27.5	5.6	32.7	0.5	35.5	53.9	18.4	*1)
Hori.	4804.000	AV	35.5	31.7	7.7	31.7	0.5	43.8	53.9	10.1	
Hori.	7206.000	AV	33.8	36.1	9.1	32.6	-	46.4	53.9	7.5	Floor noise
Hori.	9608.000	AV	32.4	38.7	9.5	33.3	-	47.3	53.9	6.6	Floor noise
Vert.	55.300	QP	44.2	9.2	7.6	32.2	-	28.8	40.0	11.2	
Vert.	84.000	QP	48.9	7.6	8.0	32.2	-	32.4	40.0	7.6	
Vert.	108.000	QP	38.2	11.2	8.3	32.1	-	25.5	43.5	18.0	
Vert.	144.000	QP	35.8	14.9	8.7	32.1	-	27.3	43.5	16.2	
Vert.	276.000	QP	45.7	13.2	9.9	32.0	-	36.8	46.0	9.2	
Vert.	480.000	QP	40.8	17.2	11.3	32.0	-	37.3	46.0	8.7	
Vert.	2390.000	PK	42.8	27.5	5.6	32.7	-	43.2	73.9	30.7	
Vert.	4804.000	PK	42.5	31.7	7.7	31.7	-	50.3	73.9	23.6	
Vert.	7206.000	PK	42.4	36.1	9.1	32.6	-	55.0	73.9	18.9	Floor noise
Vert.	9608.000	PK	42.9	38.7	9.5	33.3	-	57.8	73.9	16.1	Floor noise
Vert.	2390.000	AV	34.4	27.5	5.6	32.7	0.5	35.3	53.9	18.6	*1)
Vert.	4804.000	AV	35.5	31.7	7.7	31.7	0.5	43.8	53.9	10.1	
Vert.	7206.000	AV	33.5	36.1	9.1	32.6	-	46.0	53.9	7.9	Floor noise
Vert.	9608.000	AV	32.8	38.7	9.5	33.3	-	47.8	53.9	6.2	Floor noise

Result = Reading + Ant Factor + Loss (Cable+Attenuator+Filter+Distance factor(above 1 GHz)) - Gain(Amplifier) + Duty factor

*Other frequency noises omitted in this report were not seen or had enough margin (more than 20 dB).

Distance factor: 1 GHz - 10 GHz $20\log(4.0\text{ m} / 3.0\text{ m}) = 2.5\text{ dB}$
10 GHz - 26.5 GHz $20\log(1.0\text{ m} / 3.0\text{ m}) = -9.5\text{ dB}$

*1) Not Out of Band emission(Leakage Power)

20dBc Data Sheet

Polarity	Frequency [MHz]	Detector	Reading [dBuV]	Ant Factor [dB/m]	Loss [dB]	Gain [dB]	Result [dBuV/m]	Limit [dBuV/m]	Margin [dB]	Remark
Hori.	2402.000	PK	100.7	27.5	5.6	32.7	101.1	-	-	Carrier
Hori.	2398.950	PK	51.2	27.5	5.6	32.7	51.6	81.1	29.5	
Hori.	2400.000	PK	61.8	27.5	5.6	32.7	62.1	81.1	18.9	
Vert.	2402.000	PK	100.5	27.5	5.6	32.7	100.8	-	-	Carrier
Vert.	2398.950	PK	50.0	27.5	5.6	32.7	50.4	80.8	30.4	
Vert.	2400.000	PK	62.0	27.5	5.6	32.7	62.3	80.8	18.5	

Result = Reading + Ant Factor + Loss (Cable+Attenuator+Filter+Distance factor(above 1 GHz)) - Gain(Amplifier)

UL Japan, Inc.

Ise EMC Lab.

4383-326 Asama-cho, Ise-shi, Mie-ken 516-0021 JAPAN

Telephone : +81 596 24 8999

Facsimile : +81 596 24 8124

Radiated Spurious Emission
(Reference Plot for band-edge)

Report No. 13477241H
Test place Ise EMC Lab.
Semi Anechoic Chamber No.3
Date November 2, 2020
Temperature / Humidity 23 deg. C / 50 % RH
Engineer Takeshi Hiyaji
(Above 1 GHz)
Mode Tx BT LE 2M-PHY 2402 MHz

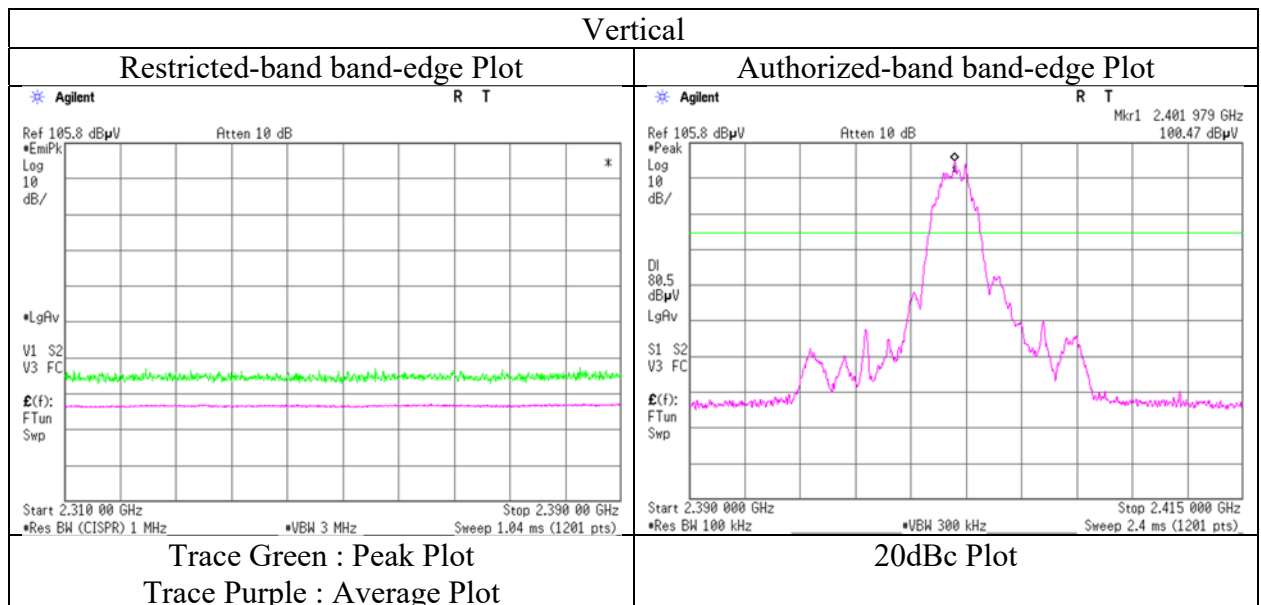
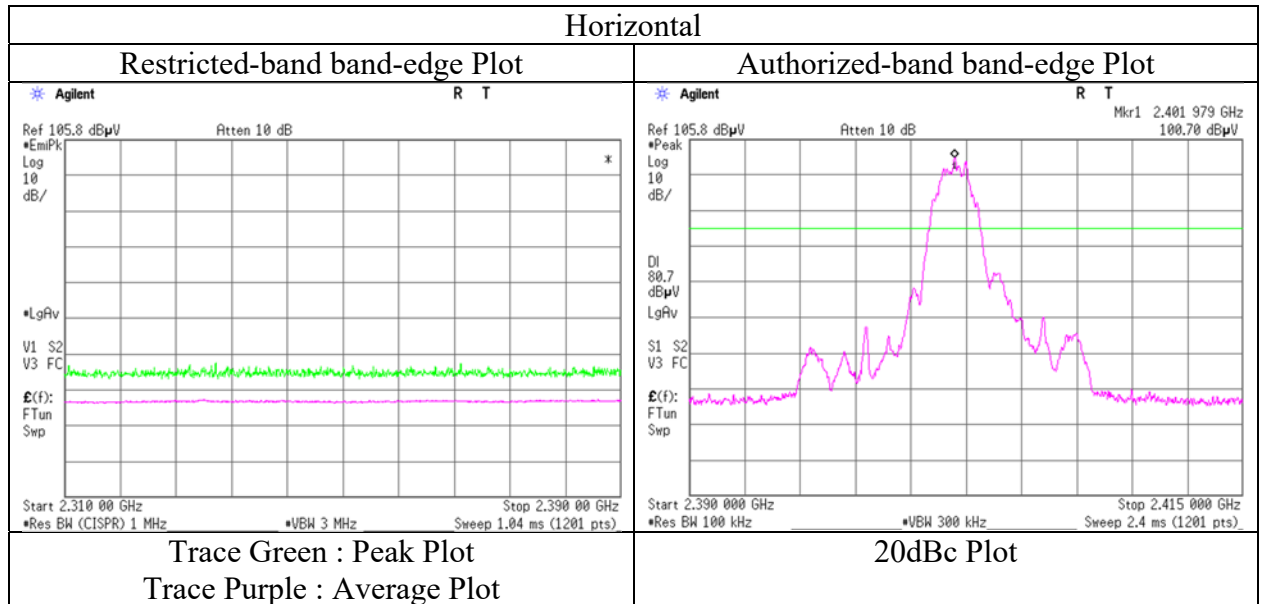

* The measurement was conducted for a sufficiently long enough time to detect any possible spurious emissions. Final result of restricted band edge was shown in tabular data.

Radiated Spurious Emission

Report No. 13477241H
Test place Ise EMC Lab.
Semi Anechoic Chamber No.3 No.3
Date November 2, 2020 November 3, 2020
Temperature / Humidity 23 deg. C / 50 % RH 23 deg. C / 38 % RH
Engineer Takeshi Hiyaji Takeshi Hiyaji
(Above 1 GHz) (Below 1 GHz)
Mode Tx BT LE 2M-PHY 2440 MHz

Polarity	Frequency [MHz]	Detector	Reading [dBuV]	Ant.Fac. [dB/m]	Loss [dB]	Gain [dB]	Duty Factor [dB]	Result [dBuV/m]	Limit [dBuV/m]	Margin [dB]	Remark
Hori.	55.300	QP	37.9	9.2	7.6	32.2	-	22.5	40.0	17.5	
Hori.	84.000	QP	38.8	7.6	8.0	32.2	-	22.3	40.0	17.8	
Hori.	108.000	QP	26.2	11.2	8.3	32.1	-	13.5	43.5	30.0	
Hori.	144.000	QP	35.3	14.9	8.7	32.1	-	26.8	43.5	16.7	
Hori.	276.000	QP	43.8	13.2	9.9	32.0	-	34.9	46.0	11.1	
Hori.	480.000	QP	40.8	17.2	11.3	32.0	-	37.3	46.0	8.7	
Hori.	4880.000	PK	41.6	31.5	7.7	31.6	-	49.1	73.9	24.8	
Hori.	7320.000	PK	41.7	36.2	9.1	32.6	-	54.3	73.9	19.6	Floor noise
Hori.	9760.000	PK	42.2	39.0	9.6	33.4	-	57.4	73.9	16.5	Floor noise
Hori.	4880.000	AV	34.1	31.5	7.7	31.6	0.5	42.2	53.9	11.7	
Hori.	7320.000	AV	34.4	36.2	9.1	32.6	-	47.1	53.9	6.8	Floor noise
Hori.	9760.000	AV	32.2	39.0	9.6	33.4	-	47.4	53.9	6.5	Floor noise
Vert.	55.300	QP	45.2	9.2	7.6	32.2	-	29.8	40.0	10.2	
Vert.	84.000	QP	47.5	7.6	8.0	32.2	-	31.0	40.0	9.1	
Vert.	108.000	QP	37.7	11.2	8.3	32.1	-	25.0	43.5	18.5	
Vert.	144.000	QP	35.5	14.9	8.7	32.1	-	27.0	43.5	16.5	
Vert.	276.000	QP	47.2	13.2	9.9	32.0	-	38.3	46.0	7.7	
Vert.	480.000	QP	41.6	17.2	11.3	32.0	-	38.1	46.0	7.9	
Vert.	4880.000	PK	41.8	31.5	7.7	31.6	-	49.3	73.9	24.6	
Vert.	7320.000	PK	41.5	36.2	9.1	32.6	-	54.1	73.9	19.8	Floor noise
Vert.	9760.000	PK	41.8	39.0	9.6	33.4	-	57.0	73.9	16.9	Floor noise
Vert.	4880.000	AV	34.7	31.5	7.7	31.6	0.5	42.8	53.9	11.1	
Vert.	7320.000	AV	34.4	36.2	9.1	32.6	-	47.0	53.9	6.9	Floor noise
Vert.	9760.000	AV	32.3	39.0	9.6	33.4	-	47.5	53.9	6.4	Floor noise

Result = Reading + Ant Factor + Loss (Cable+Attenuator+Filter+Distance factor(above 1 GHz)) - Gain(Amplifier) + Duty factor

*Other frequency noises omitted in this report were not seen or had enough margin (more than 20 dB).

Distance factor: 1 GHz - 10 GHz 20log (4.0 m / 3.0 m) = 2.5 dB
10 GHz - 26.5 GHz 20log (1.0 m / 3.0 m) = -9.5 dB

Radiated Spurious Emission

Report No. 13477241H
Test place Ise EMC Lab.
Semi Anechoic Chamber No.3 No.3
Date November 2, 2020 November 3, 2020
Temperature / Humidity 23 deg. C / 50 % RH 23 deg. C / 38 % RH
Engineer Takeshi Hiyaji Takeshi Hiyaji
(Above 1 GHz) (Below 1 GHz)
Mode Tx BT LE 2M-PHY 2480 MHz

Polarity	Frequency [MHz]	Detector	Reading [dBuV]	Ant.Fac. [dB/m]	Loss [dB]	Gain [dB]	Duty Factor [dB]	Result [dBuV/m]	Limit [dBuV/m]	Margin [dB]	Remark
Hori.	55.300	QP	39.5	9.2	7.6	32.2	-	24.1	40.0	15.9	
Hori.	84.000	QP	38.6	7.6	8.0	32.2	-	22.1	40.0	18.0	
Hori.	108.000	QP	26.0	11.2	8.3	32.1	-	13.3	43.5	30.2	
Hori.	144.000	QP	35.6	14.9	8.7	32.1	-	27.1	43.5	16.4	
Hori.	276.000	QP	44.3	13.2	9.9	32.0	-	35.4	46.0	10.6	
Hori.	480.000	QP	41.6	17.2	11.3	32.0	-	38.1	46.0	7.9	
Hori.	2483.500	PK	53.8	27.3	5.7	32.7	-	54.1	73.9	19.8	
Hori.	4960.000	PK	42.0	31.5	7.7	31.6	-	49.6	73.9	24.3	
Hori.	7440.000	PK	41.4	36.3	9.1	32.7	-	54.1	73.9	19.9	Floor noise
Hori.	9920.000	PK	42.3	38.8	9.6	33.5	-	57.2	73.9	16.7	Floor noise
Hori.	2483.500	AV	47.1	27.3	5.7	32.7	0.5	47.9	53.9	6.0	*1)
Hori.	4960.000	AV	35.4	31.5	7.7	31.6	0.5	43.5	53.9	10.4	
Hori.	7440.000	AV	33.9	36.3	9.1	32.7	-	46.6	53.9	7.4	Floor noise
Hori.	9920.000	AV	32.2	38.8	9.6	33.5	-	47.1	53.9	6.8	Floor noise
Vert.	55.300	QP	47.8	9.2	7.6	32.2	-	32.4	40.0	7.6	
Vert.	84.000	QP	46.5	7.6	8.0	32.2	-	30.0	40.0	10.1	
Vert.	108.000	QP	36.8	11.2	8.3	32.1	-	24.1	43.5	19.4	
Vert.	144.000	QP	34.2	14.9	8.7	32.1	-	25.7	43.5	17.8	
Vert.	276.000	QP	47.1	13.2	9.9	32.0	-	38.2	46.0	7.8	
Vert.	480.000	QP	40.9	17.2	11.3	32.0	-	37.4	46.0	8.6	
Vert.	2483.500	PK	53.1	27.3	5.7	32.7	-	53.4	73.9	20.5	
Vert.	4960.000	PK	42.4	31.5	7.7	31.6	-	49.9	73.9	24.0	
Vert.	7440.000	PK	41.4	36.3	9.1	32.7	-	54.1	73.9	19.8	Floor noise
Vert.	9920.000	PK	42.7	38.8	9.6	33.5	-	57.7	73.9	16.3	Floor noise
Vert.	2483.500	AV	46.8	27.3	5.7	32.7	0.5	47.6	53.9	6.3	*1)
Vert.	4960.000	AV	35.9	31.5	7.7	31.6	0.5	44.0	53.9	9.9	
Vert.	7440.000	AV	33.5	36.3	9.1	32.7	-	46.1	53.9	7.8	Floor noise
Vert.	9920.000	AV	32.2	38.8	9.6	33.5	-	47.2	53.9	6.7	Floor noise

Result = Reading + Ant Factor + Loss (Cable+Attenuator+Filter+Distance factor(above 1 GHz)) - Gain(Amplifier) + Duty factor

*Other frequency noises omitted in this report were not seen or had enough margin (more than 20 dB).

Distance factor: 1 GHz - 10 GHz $20\log(4.0\text{ m} / 3.0\text{ m}) = 2.5\text{ dB}$
10 GHz - 26.5 GHz $20\log(1.0\text{ m} / 3.0\text{ m}) = -9.5\text{ dB}$

*1) Not Out of Band emission(Leakage Power)

Radiated Spurious Emission
(Reference Plot for band-edge)

Report No. 13477241H
Test place Ise EMC Lab.
Semi Anechoic Chamber No.3
Date November 2, 2020
Temperature / Humidity 23 deg. C / 50 % RH
Engineer Takeshi Hiyaji
(Above 1 GHz)
Mode Tx BT LE 2M-PHY 2480 MHz

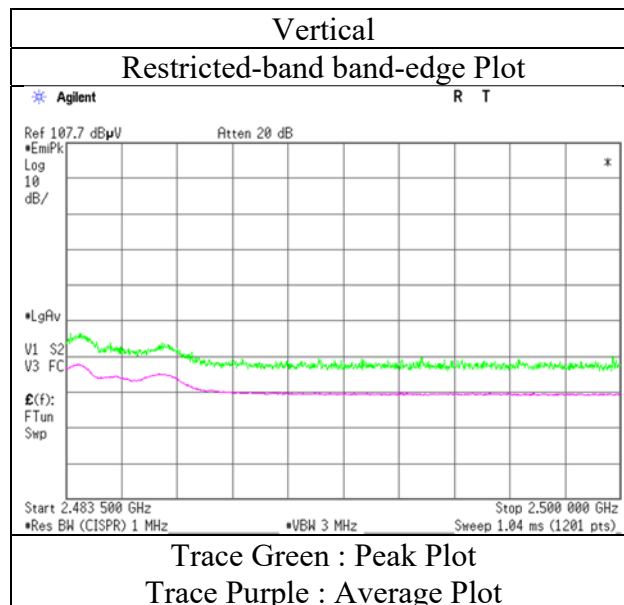
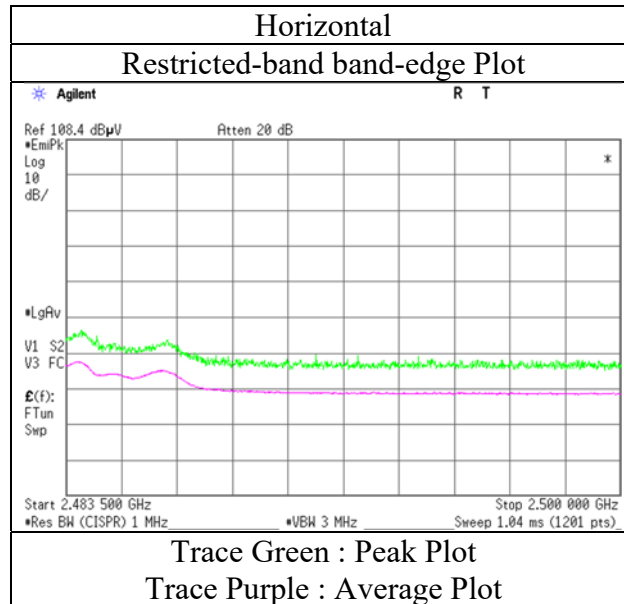

* The measurement was conducted for a sufficiently long enough time to detect any possible spurious emissions. Final result of restricted band edge was shown in tabular data.

Radiated Spurious Emission
(Plot data, Worst case)

Report No.	13477241H	
Test place	Ise EMC Lab.	
Semi Anechoic Chamber	No.3	No.3
Date	November 2, 2020	November 3, 2020
Temperature / Humidity	23 deg. C / 50 % RH	23 deg. C / 38 % RH
Engineer	Takeshi Hiyaji (Above 1 GHz)	Takeshi Hiyaji (Below 1 GHz)
Mode	Tx BT LE 2M-PHY 2402 MHz	

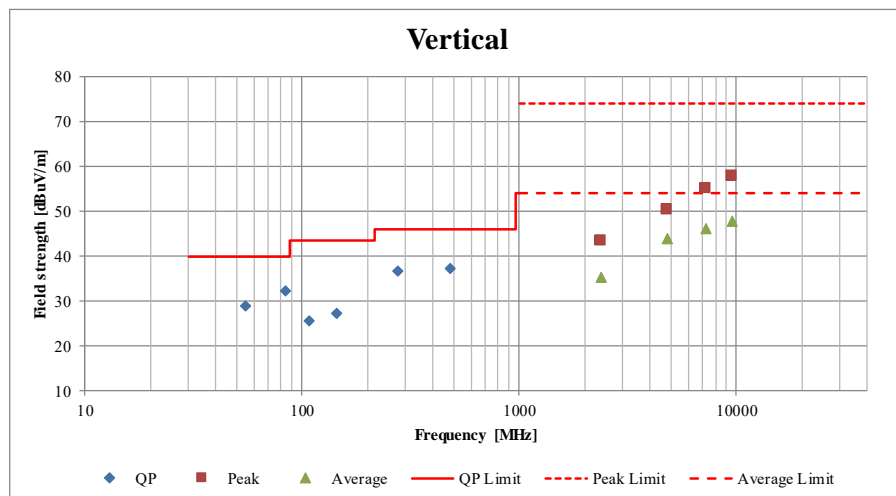
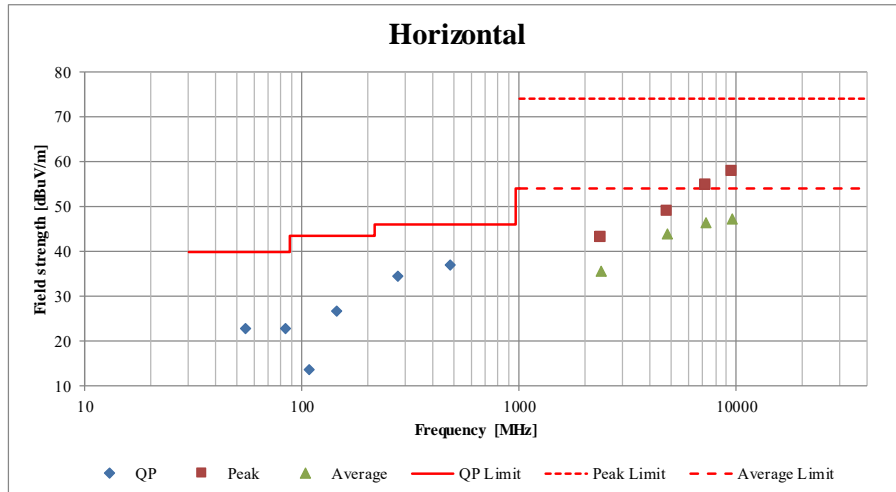

*These plots data contains sufficient number to show the trend of characteristic features for EUT.

Conducted Spurious Emission

Report No. 13477241H
Test place Ise EMC Lab. No.6 Shielded Room
Date November 2, 2020
Temperature / Humidity 21 deg. C / 52 % RH
Engineer Yuta Moriya
Mode Tx BT LE 1M-PHY 2402 MHz

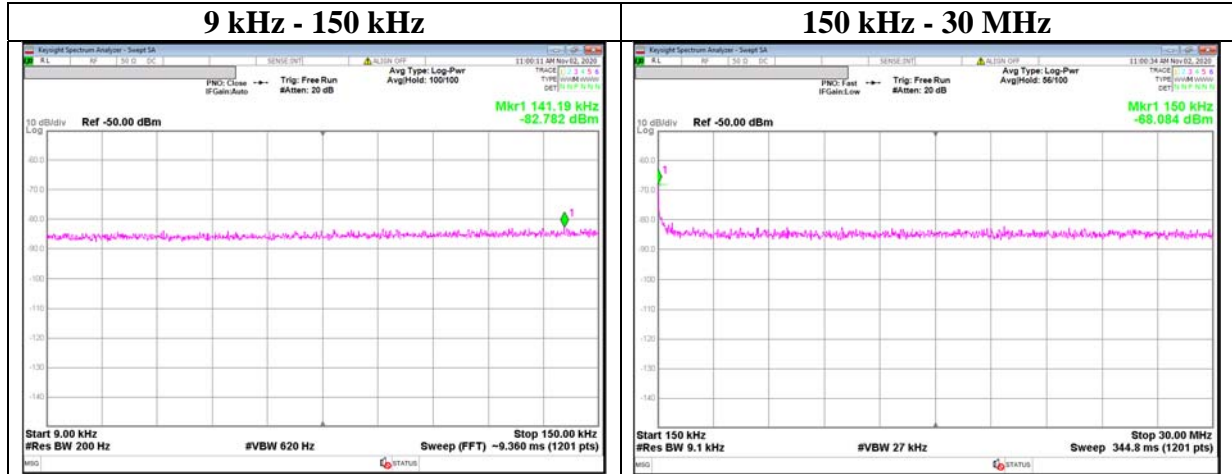

Frequency [kHz]	Reading [dBm]	Cable Loss [dB]	Attenuator Loss [dB]	Antenna Gain* [dBi]	N (Number of Output)	EIRP [dBm]	Distance [m]	Ground bounce [dB]	E (field strength) [dBuV/m]	Limit [dBuV/m]	Margin [dB]	Remark
141.19	-82.7	1.14	10.1	2.0	1	-69.5	300	6.0	-8.2	24.6	32.8	
150.00	-68.0	1.14	10.1	2.0	1	-54.8	300	6.0	6.5	24.0	17.5	

$$E \text{ [dBuV/m]} = \text{EIRP [dBm]} - 20 \log (\text{Distance [m]}) + \text{Ground bounce [dB]} + 104.8 \text{ [dBuV/m]}$$

$$\text{EIRP [dBm]} = \text{Reading [dBm]} + \text{Cable loss [dB]} + \text{Attenuator Loss [dB]} + \text{Antenna gain [dBi]} + 10 * \log (N)$$

N: Number of output

*2.0 dBi was applied to the test result based on ANSI C63.10 since antenna gain was less than 2.0 dBi.

Conducted Spurious Emission

Report No. 13477241H
Test place Ise EMC Lab. No.6 Shielded Room
Date November 2, 2020
Temperature / Humidity 21 deg. C / 52 % RH
Engineer Yuta Moriya
Mode Tx BT LE 1M-PHY 2440 MHz

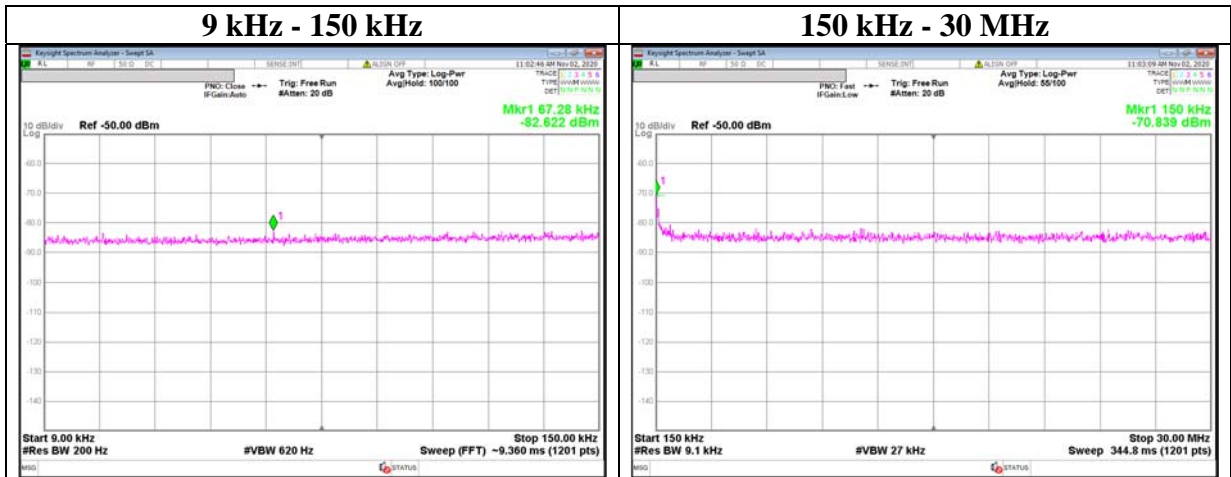

Frequency [kHz]	Reading [dBm]	Cable Loss [dB]	Attenuator Loss [dB]	Antenna Gain* [dBi]	N (Number of Output)	EIRP [dBm]	Distance [m]	Ground bounce [dB]	E (field strength) [dBuV/m]	Limit [dBuV/m]	Margin [dB]	Remark
67.28	-82.6	1.15	10.1	2.0	1	-69.4	300	6.0	-8.1	31.0	39.1	
150.00	-70.8	1.15	10.1	2.0	1	-57.6	300	6.0	3.7	24.0	20.3	

$$E \text{ [dBuV/m]} = \text{EIRP [dBm]} - 20 \log(\text{Distance [m]}) + \text{Ground bounce [dB]} + 104.8 \text{ [dBuV/m]}$$

$$\text{EIRP [dBm]} = \text{Reading [dBm]} + \text{Cable loss [dB]} + \text{Attenuator Loss [dB]} + \text{Antenna gain [dBi]} + 10 * \log(N)$$

N: Number of output

*2.0 dBi was applied to the test result based on ANSI C63.10 since antenna gain was less than 2.0 dBi.

Conducted Spurious Emission

Report No. 13477241H
Test place Ise EMC Lab. No.6 Shielded Room
Date November 2, 2020
Temperature / Humidity 21 deg. C / 52 % RH
Engineer Yuta Moriya
Mode Tx BT LE 1M-PHY 2480 MHz

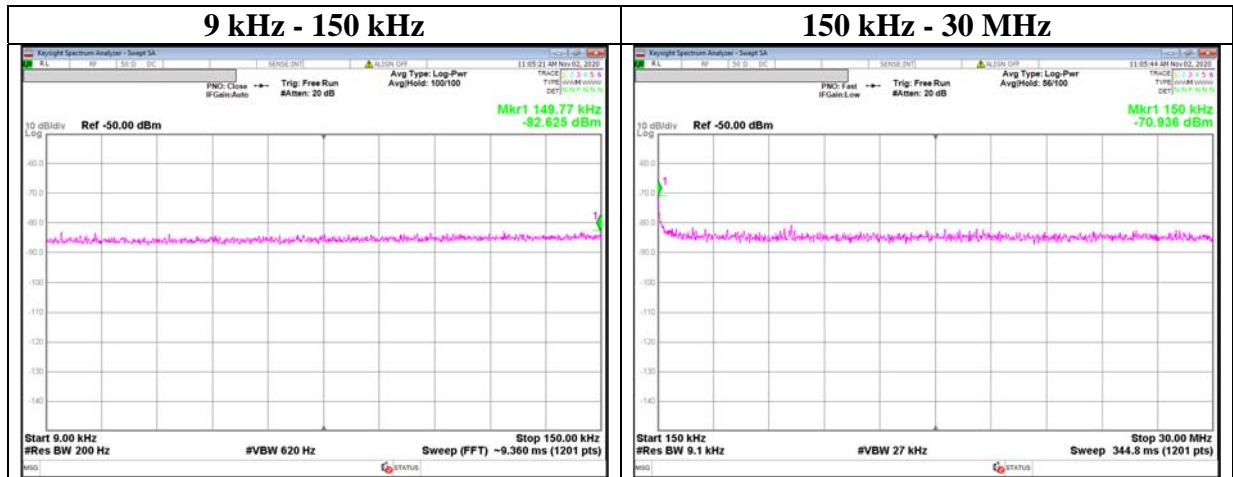

Frequency [kHz]	Reading [dBm]	Cable Loss [dB]	Attenuator Loss [dB]	Antenna Gain* [dBi]	N (Number of Output)	EIRP [dBm]	Distance [m]	Ground bounce [dB]	E (field strength) [dBuV/m]	Limit [dBuV/m]	Margin [dB]	Remark
149.77	-82.6	1.15	10.1	2.0	1	-69.4	300	6.0	-8.1	24.0	32.1	
150.00	-70.9	1.15	10.1	2.0	1	-57.7	300	6.0	3.6	24.0	20.4	

$$E \text{ [dBuV/m]} = \text{EIRP [dBm]} - 20 \log (\text{Distance [m]}) + \text{Ground bounce [dB]} + 104.8 \text{ [dBuV/m]}$$

$$\text{EIRP [dBm]} = \text{Reading [dBm]} + \text{Cable loss [dB]} + \text{Attenuator Loss [dB]} + \text{Antenna gain [dBi]} + 10 * \log (N)$$

N: Number of output

*2.0 dBi was applied to the test result based on ANSI C63.10 since antenna gain was less than 2.0 dBi.

Conducted Spurious Emission

Report No. 13477241H
Test place Ise EMC Lab. No.6 Shielded Room
Date November 2, 2020
Temperature / Humidity 21 deg. C / 52 % RH
Engineer Yuta Moriya
Mode Tx BT LE 2M-PHY 2402 MHz

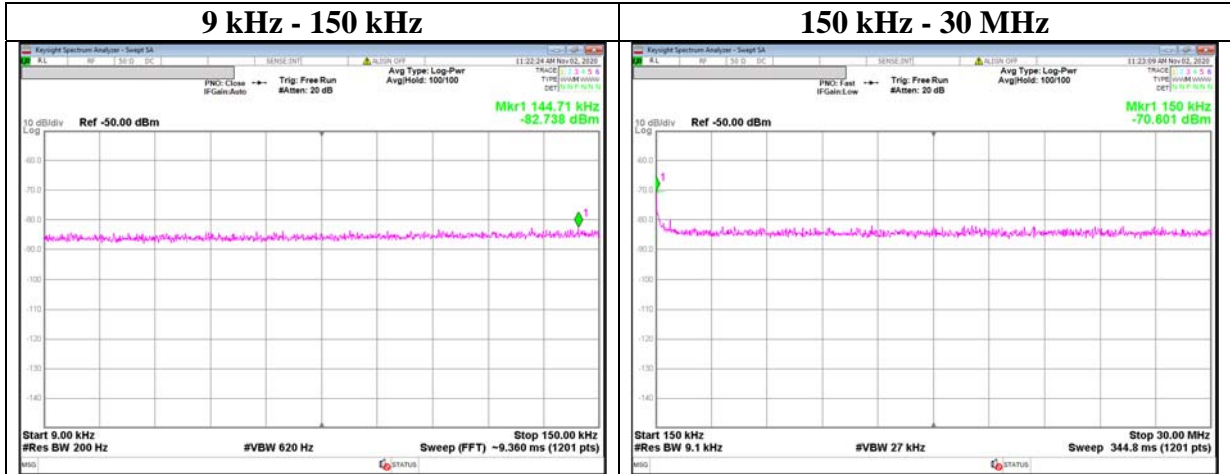

Frequency [kHz]	Reading [dBm]	Cable Loss [dB]	Attenuator Loss [dB]	Antenna Gain* [dBi]	N (Number of Output)	EIRP [dBm]	Distance [m]	Ground bounce [dB]	E (field strength) [dBuV/m]	Limit [dBuV/m]	Margin [dB]	Remark
144.71	-82.7	1.14	10.1	2.0	1	-69.5	300	6.0	-8.2	24.3	32.5	
150.00	-70.6	1.14	10.1	2.0	1	-57.4	300	6.0	3.9	24.0	20.1	

$$E \text{ [dBuV/m]} = \text{EIRP [dBm]} - 20 \log (\text{Distance [m]}) + \text{Ground bounce [dB]} + 104.8 \text{ [dBuV/m]}$$

$$\text{EIRP [dBm]} = \text{Reading [dBm]} + \text{Cable loss [dB]} + \text{Attenuator Loss [dB]} + \text{Antenna gain [dBi]} + 10 * \log (N)$$

N: Number of output

*2.0 dBi was applied to the test result based on ANSI C63.10 since antenna gain was less than 2.0 dBi.

Conducted Spurious Emission

Report No. 13477241H
Test place Ise EMC Lab. No.6 Shielded Room
Date November 2, 2020
Temperature / Humidity 21 deg. C / 52 % RH
Engineer Yuta Moriya
Mode Tx BT LE 2M-PHY 2440 MHz

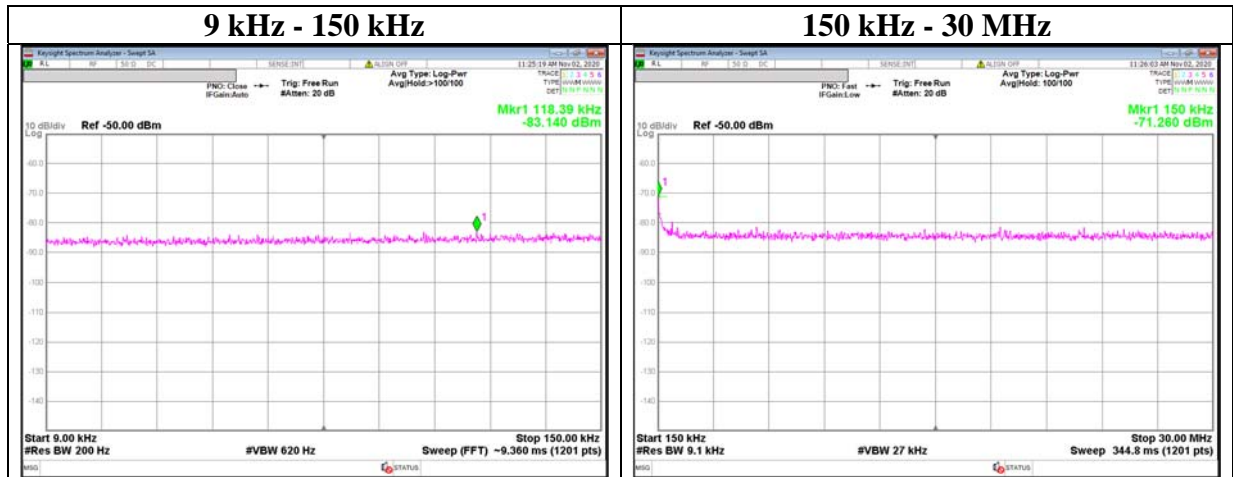

Frequency [kHz]	Reading [dBm]	Cable Loss [dB]	Attenuator Loss [dB]	Antenna Gain* [dBi]	N (Number of Output)	EIRP [dBm]	Distance [m]	Ground bounce [dB]	E (field strength) [dBuV/m]	Limit [dBuV/m]	Margin [dB]	Remark
118.39	-83.1	1.15	10.1	2.0	1	-69.9	300	6.0	-8.6	26.1	34.7	
150.00	-71.2	1.15	10.1	2.0	1	-58.0	300	6.0	3.3	24.0	20.7	

$$E \text{ [dBuV/m]} = \text{EIRP [dBm]} - 20 \log(\text{Distance [m]}) + \text{Ground bounce [dB]} + 104.8 \text{ [dBuV/m]}$$

$$\text{EIRP [dBm]} = \text{Reading [dBm]} + \text{Cable loss [dB]} + \text{Attenuator Loss [dB]} + \text{Antenna gain [dBi]} + 10 * \log(N)$$

N: Number of output

*2.0 dBi was applied to the test result based on ANSI C63.10 since antenna gain was less than 2.0 dBi.

Conducted Spurious Emission

Report No. 13477241H
Test place Ise EMC Lab. No.6 Shielded Room
Date November 2, 2020
Temperature / Humidity 21 deg. C / 52 % RH
Engineer Yuta Moriya
Mode Tx BT LE 2M-PHY 2480 MHz

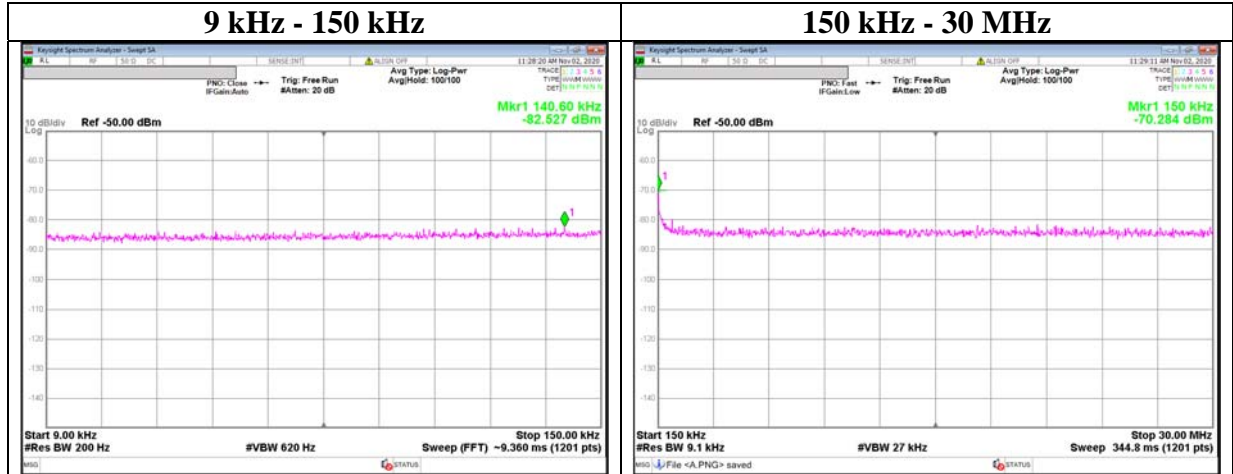

Frequency [kHz]	Reading [dBm]	Cable Loss [dB]	Attenuator Loss [dB]	Antenna Gain* [dBi]	N (Number of Output)	EIRP [dBm]	Distance [m]	Ground bounce [dB]	E (field strength) [dBuV/m]	Limit [dBuV/m]	Margin [dB]	Remark
140.60	-82.5	1.15	10.1	2.0	1	-69.3	300	6.0	-8.0	24.6	32.6	
150.00	-70.2	1.15	10.1	2.0	1	-57.0	300	6.0	4.3	24.0	19.7	

$$E \text{ [dBuV/m]} = \text{EIRP [dBm]} - 20 \log (\text{Distance [m]}) + \text{Ground bounce [dB]} + 104.8 \text{ [dBuV/m]}$$

$$\text{EIRP [dBm]} = \text{Reading [dBm]} + \text{Cable loss [dB]} + \text{Attenuator Loss [dB]} + \text{Antenna gain [dBi]} + 10 * \log (N)$$

N: Number of output

*2.0 dBi was applied to the test result based on ANSI C63.10 since antenna gain was less than 2.0 dBi.

Power Density

Report No. 13477241H
Test place Ise EMC Lab. No.6 Shielded Room
Date November 2, 2020
Temperature / Humidity 21 deg. C / 52 % RH
Engineer Yuta Moriya
Mode Tx

BT LE 1M-PHY

Freq. [MHz]	Reading [dBm]	Cable Loss [dB]	Atten. Loss [dB]	Result [dBm]	Limit [dBm]	Margin [dB]
2402	-19.88	1.14	10.10	-8.64	8.00	16.64
2440	-20.22	1.15	10.10	-8.97	8.00	16.97
2480	-20.35	1.15	10.10	-9.10	8.00	17.10

BT LE 2M-PHY

Freq. [MHz]	Reading [dBm]	Cable Loss [dB]	Atten. Loss [dB]	Result [dBm]	Limit [dBm]	Margin [dB]
2402	-20.03	1.14	10.10	-8.79	8.00	16.79
2440	-20.14	1.15	10.10	-8.89	8.00	16.89
2480	-20.16	1.15	10.10	-8.91	8.00	16.91

Sample Calculation:

Result = Reading + Cable Loss (including the cable(s) customer supplied) + Attenuator Loss

*The equipment and cables were not used for factor 0 dB of the data sheets.

Power Density

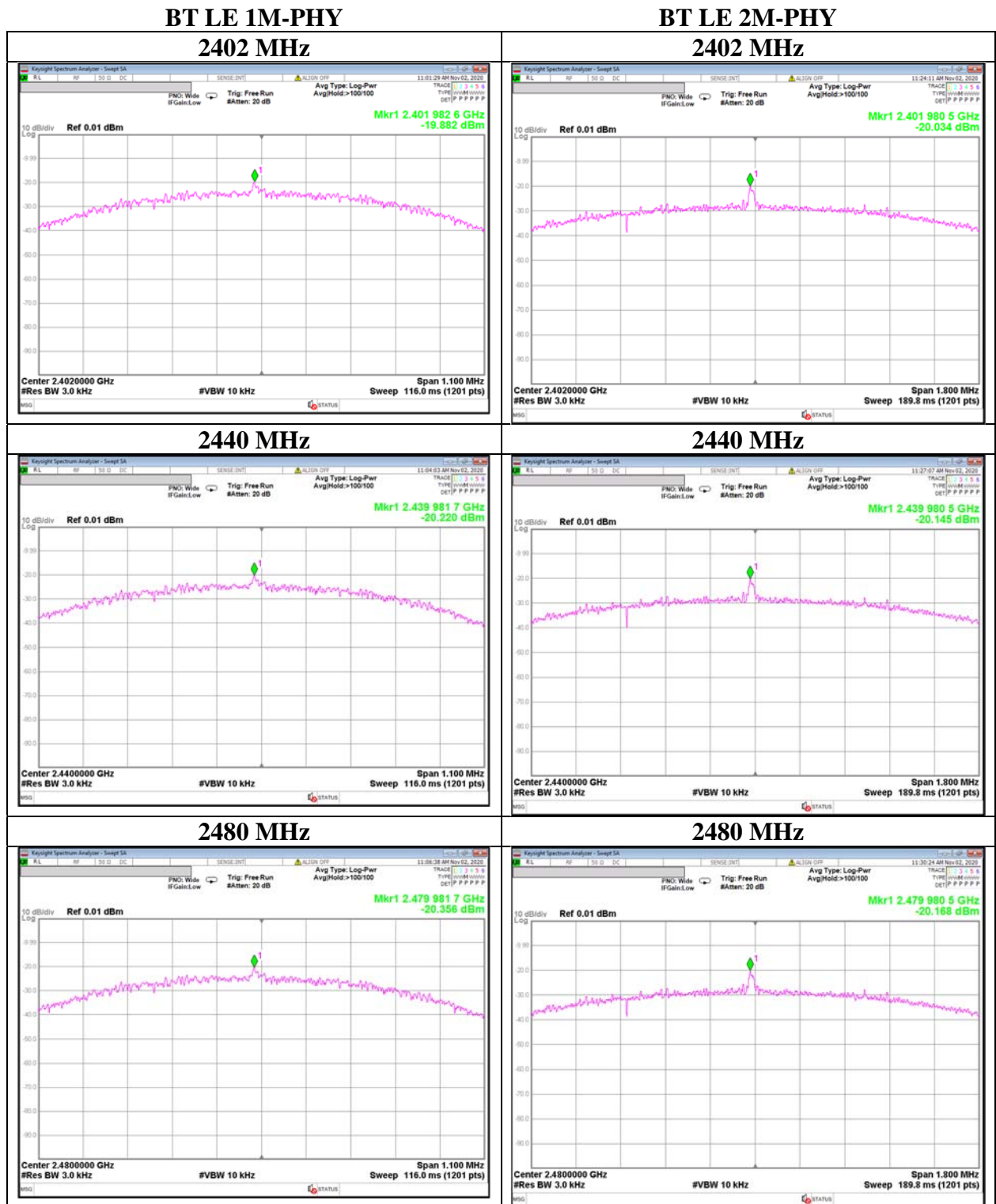

UL Japan, Inc.
Ise EMC Lab.

4383-326 Asama-cho, Ise-shi, Mie-ken 516-0021 JAPAN
 Telephone : +81 596 24 8999
 Facsimile : +81 596 24 8124

APPENDIX 2: Test instruments

Test equipment

Test Item	Local ID	LIMS ID	Description	Manufacturer	Model	Serial	Last Calibration Date	Cal Int
RE	MAEC-03-SVSWR	142013	AC3_Semi Anechoic Chamber(SVSWR)	TDK	Semi Anechoic Chamber 3m	DA-10005	2019/04/08	24
RE	MOS-13	141554	Thermo-Hygrometer	CUSTOM. Inc	CTH-201	1301	2020/01/07	12
RE	MMM-08	141532	DIGITAL HiTESTER	Hioki	3805	51201197	2020/01/06	12
RE	MJM-16	142183	Measure	KOMELON	KMC-36	-	-	-
RE	COTS-MEMI-02	178648	EMI measurement program	TSJ (Techno Science Japan)	TEPTO-DV	-	-	-
RE	MHA-20	141507	Horn Antenna 1-18GHz	Schwarzbeck Mess - Elektronik	BBHA9120D	258	2020/10/01	12
RE	MPA-11	141580	MicroWave System Amplifier	Keysight Technologies Inc	83017A	MY39500779	2020/03/24	12
RE	MCC-231	177964	Microwave Cable	Junkosha INC.	MMX221	1901S329(1m)/1902S579(5m)	2020/03/02	12
RE	MSA-04	141885	Spectrum Analyzer	Keysight Technologies Inc	E4448A	US44300523	2020/11/09	12
RE	MHF-25	141232	High Pass Filter 3.5-18.0GHz	UL Japan	HPF SELECTOR	001	2020/09/23	12
AT	MRENT-146	185691	Spectrum Analyzer	Keysight Technologies Inc	N9020A	MY55400351	2020/09/23	12
AT	MPM-12	141809	Power Meter	ANRITSU	ML2495A	825002	2020/05/07	12
AT	MPSE-17	141830	Power sensor	ANRITSU	MA2411B	738285	2020/05/07	12
AT	MAT-23	141361	Attenuator(10dB) 1-18GHz	Orient Microwave	BX10-0476-00	-	2020/04/21	12
AT	MCC-244	197219	Microwave cable	HUBER+SUNER	SF126E/11PC35/11PC35/2000MM	536999/126E	2020/03/23	12
AT	MOS-24	90289	Thermo-Hygrometer	CUSTOM. Inc	CTH-201	0005	2020/01/07	12
RE	MAT-95	142314	Attenuator	Pasternack	PE7390-6	D/C 1504	2020/06/17	12
RE	MBA-03	141424	Biconical Antenna	Schwarzbeck Mess - Elektronik	VHA9103+BBA9106	1915	2020/08/13	12
RE	MHA-16	141513	Horn Antenna 15-40GHz	Schwarzbeck Mess - Elektronik	BBHA9170	BBHA9170306	2020/05/21	12
RE	MCC-51	141323	Coaxial cable	UL Japan	-	-	2020/07/06	12
RE	MLA-22	141266	Logperiodic Antenna(200-1000MHz)	Schwarzbeck Mess - Elektronik	VUSLP9111B	9111B-191	2020/08/13	12
RE	MPA-13	141582	Pre Amplifier	SONOMA INSTRUMENT	310	260834	2020/02/10	12
RE	MTR-10	141951	EMI Test Receiver	Rohde & Schwarz	ESR26	101408	2020/03/10	12
RE	MAEC-03	142008	AC3_Semi Anechoic Chamber(NSA)	TDK	Semi Anechoic Chamber 3m	DA-10005	2020/05/22	24
CE	MAT-64	141290	Attenuator(13dB)	JFW Industries, Inc.	50FP-013H2 N	-	2019/12/02	12
CE	MTR-10	141951	EMI Test Receiver	Rohde & Schwarz	ESR26	101408	2020/03/10	12
CE	MCC-112	141216	Coaxial cable	Fujikura/Suhner/TSJ	5D-2W/SFM14/sucoform141-PE/421-010/RFM-E321(SW)	-/00640	2020/07/06	12
CE	MLS-25	141537	LISN(AMN)	Schwarzbeck Mess - Elektronik	NSLK8127	8127-731	2020/07/21	12
CE	MAEC-03	142008	AC3_Semi Anechoic Chamber(NSA)	TDK	Semi Anechoic Chamber 3m	DA-10005	2020/05/22	24
CE	MOS-13	141554	Thermo-Hygrometer	CUSTOM. Inc	CTH-201	1301	2020/01/07	12
CE	MMM-08	141532	DIGITAL HiTESTER	Hioki	3805	51201197	2020/01/06	12
CE	MJM-16	142183	Measure	KOMELON	KMC-36	-	-	-
CE	COTS-MEMI-02	178648	EMI measurement program	TSJ (Techno Science Japan)	TEPTO-DV	-	-	-

UL Japan, Inc.

Ise EMC Lab.

4383-326 Asama-cho, Ise-shi, Mie-ken 516-0021 JAPAN

Telephone : +81 596 24 8999

Facsimile : +81 596 24 8124

*Hyphens for Last Calibration Date and Cal Int (month) are instruments that Calibration is not required (e.g. software), or instruments checked in advance before use.

The expiration date of the calibration is the end of the expired month.

As for some calibrations performed after the tested dates, those test equipment have been controlled by means of an unbroken chains of calibrations.

All equipment is calibrated with valid calibrations. Each measurement data is traceable to the national or international standards.

Test item: CE: Conducted Emission test
 RE: Radiated Emission test
 AT: Antenna Terminal Conducted test