



RADIO TEST REPORT

Test Report No. : 11242579M-D

Applicant : CASIO COMPUTER CO., LTD.
Type of Equipment : Handheld Terminal
Model No. : IT-G500-C21E-US
FCC ID : BBQITG500
Test regulation : FCC Part 15 Subpart E: 2016
(DFS test only)
Test Result : Complied

1. This test report shall not be reproduced in full or partial, without the written approval of UL Japan, Inc.
2. The results in this report apply only to the sample tested.
3. This sample tested is in compliance with the above regulation.
4. The test results in this report are traceable to the national or international standards.
5. The opinions and the interpretations to the result of the description in this report are outside scopes where UL Japan has been accredited.
6. This test report covers Radio technical requirements. It does not cover administrative issues such as Manual or non-Radio test related Requirements. (if applicable)

Date of test: June 6, 2016

Representative test engineer: 
Kazuhiro Ando
Engineer
Consumer Technology Division

Approved by: 
Masanori Nishiyama
Manager
Consumer Technology Division



CERTIFICATE 1266.01

- The testing in which "Non-accreditation" is displayed is outside the accreditation scopes in UL Japan.
 There is no testing item of "Non-accreditation".

UL Japan, Inc.

Kashima EMC Lab.

1614, Mushihata, Katori-shi, Chiba-ken, 289-0341 Japan
Telephone: +81-478-88-6500
Facsimile: +81-478-82-3373

CONTENTS	PAGE
SECTION 1: Customer information.....	4
SECTION 2: Equipment under test (E.U.T.).....	4
SECTION 3: Scope of Report.....	6
SECTION 4: Test specification, procedures & results.....	6
SECTION 5: Operation of E.U.T. during testing.....	11
SECTION 6: Channel Move Time, Channel Closing Transmission Time.....	16
SECTION 7: Non-Occupancy Period	18
APPENDIX 2: Photographs of test setup	21

SECTION 1: Customer information

Company Name : CASIO COMPUTER CO., LTD.
Address : 2951-5, Ishikawa-Machi, Hachioji-shi Tokyo 192-8556, Japan
Telephone Number : +81-42-639-5188
Facsimile Number : +81-42-639-5046
Contact Person : KATSUMASA MOTOKI

SECTION 2: Equipment under test (E.U.T.)

2.1 Identification of E.U.T.

Type of Equipment : Handheld Terminal
Model No. : IT-G500-C21E-US
Serial No. : Refer to Section 5, Clause 5.2
Rating : Li-ion battery DC3.7V 1850mAh/6.9Wh, M/N:HA-D20BAT-A
Option Battery : Li-ion battery DC3.7V 3700mAh/14Wh, M/N:HA-D21LBAT-A
Receipt Date of Sample : April 18, 2016
Country of Mass-production : Japan
Condition of EUT : Production prototype
(Not for Sale: This sample is equivalent to mass-produced items.)
Modification of EUT : No Modification by the test lab

2.2 Product Description

Model No: IT-G500-C21E-US (referred to as the EUT in this report) is the Handheld Terminal.

General Specification

Clock frequency(ies) in the system	CPU: 1.5 GHz
Power Supply (inner)	DC 3.3 V / 1.8 V

UL Japan, Inc.

Kashima EMC Lab.

1614, Mushiata, Katori-shi, Chiba-ken, 289-0341 Japan

Telephone: +81-478-88-6500

Facsimile: +81-478-82-3373

Radio Specification

WLAN (IEEE802.11b/g/a/n-20)

Equipment Type	Transceiver
Frequency of Operation	2412-2462MHz, 5180-5825MHz
Type of Modulation	DSSS, OFDM
Antenna type	Inverted F antenna (IEEE802.11b/g/n) Dipole antenna (IEEE802.11a/n)
Antenna Gain	0.79dBi (2412-2462MHz) 1.05dBi (5180-5825MHz)

BT

Equipment Type	Transceiver
Frequency of Operation	2402-2480MHz
Type of Modulation	FHSS
Antenna type	Inverted F antenna
Antenna Gain	0.79dBi

RFID

Equipment Type	Transceiver
Frequency of Operation	13.56MHz
Type of Modulation	ASK
Antenna type	Loop antenna

- * Refer to the test reports: 11242579M-A for 2.4 GHz band (Wireless LAN part).
- * Refer to the test reports: 11242579M-B for 2.4 GHz band (Bluetooth part).
- * Refer to the test reports: 11242579M-C for 5 GHz band except DFS test.
- * Refer to the test reports: 11242579M-E for 13.56 MHz band (RFID).

SECTION 3: Scope of Report

This report only covers DFS requirement, as specified by the following referenced procedures.

SECTION 4: Test specification, procedures & results

4.1 Test Specification

Test Specification	:	FCC Part 15 Subpart E. FCC part 15 final revised on April 6, 2016.
Title	:	FCC 47CFR Part15 Radio Frequency Device Subpart E Unlicensed National Information Infrastructure Devices Section 15.407 General technical requirements
Test Specification	:	KDB905462 D02 UNII DFS Compliance Procedures New Rules v02
Title	:	COMPLIANCE MEASUREMENT PROCEDURES FOR UNLICENSED- NATIONAL INFORMATION INFRASTRUCTURE DEVICES OPERATING IN THE 5250-5350MHz AND 5470-5725MHz BANDS INCORPORATING DYNAMIC FREQUENCY SELECTION
Test Specification	:	KDB905462 D03 Client Without DFS New Rules v01r01
Title	:	U-NII CLIENT DEVICES WITHOUT RADAR DETECTION CAPABILITY

FCC Part 15.31 (e)

This EUT provides stable voltage (DC 1.8V) constantly to RF Part regardless of input voltage. Therefore, this EUT complies with the requirement.

FCC Part 15.203 Antenna requirement

It is impossible for end users to replace the antenna, because the antenna is mounted inside of the EUT. Therefore, the equipment complies with the antenna requirement of Section 15.203.

UL Japan, Inc.

Kashima EMC Lab.

1614, Mushihata, Katori-shi, Chiba-ken, 289-0341 Japan

Telephone: +81-478-88-6500

Facsimile: +81-478-82-3373

4.2 Procedures and results

Table 1: Applicability of DFS Requirements

Requirement	Operating Mode	Test Procedures & Limits	Deviation	Results
	Client without Radar Detection			
U-NII Detection Bandwidth	Not required	KDB905462 D02 UNII DFS Compliance Procedures New Rules v02	N/A	N/A
Initial Channel Availability Check Time	Not required	FCC15.407 (h)	N/A	N/A
		KDB905462 D02 UNII DFS Compliance Procedures New Rules v02		
		RSS-247 6.3		
Radar Burst at the Beginning of the Channel Availability Check Time	Not required	FCC15.407 (h)	N/A	N/A
		KDB905462 D02 UNII DFS Compliance Procedures New Rules v02		
		RSS-247 6.3		
Radar Burst at the End of the Channel Availability Check Time	Not required	FCC15.407 (h)	N/A	N/A
		KDB905462 D02 UNII DFS Compliance Procedures New Rules v02		
		RSS-247 6.3		
In-Service Monitoring for Channel Move Time, Channel Closing Transmission Time	Yes	FCC15.407 (h)	N/A	Complied
		KDB905462 D02 UNII DFS Compliance Procedures New Rules v02		
		RSS-247 6.3		
In-Service Monitoring for Non-Occupancy period	Yes *	FCC15.407 (h)	N/A	Complied
		KDB905462 D02 UNII DFS Compliance Procedures New Rules v02		
		RSS-247 6.3		
Statistical Performance Check	Not required	FCC15.407 (h)	N/A	N/A
		KDB905462 D02 UNII DFS Compliance Procedures New Rules v02		

Note: UL Japan, Inc.'s EMI Work Procedures No. 13-EM-W0422.

*Although this test was not required in FCC, KDB 905462 D02, it was performed as additional test.

UL Japan, Inc.

Kashima EMC Lab.

1614, Mushihata, Katori-shi, Chiba-ken, 289-0341 Japan

Telephone: +81-478-88-6500

Facsimile: +81-478-82-3373

Table 2 DFS Detection Thresholds for Master Devices and Client Devices With Radar Detection

Maximum Transmit Power	Value (See Notes 1,2, and 3)
≥ 200 milliwatt	-64 dBm
< 200 milliwatt and power spectral density < 10dBm/MHz	-62 dBm
< 200 milliwatt that do not meet the power spectral density requirement	-64 dBm
<p>Note 1: This is the level at the input of the receiver assuming a 0 dBi receive antenna. Note 2: Throughout these test procedures an additional 1 dB has been added to the amplitude of the test transmission waveforms to account for variations in measurement equipment. This will ensure that the test signal is at or above the detection threshold level to trigger a DFS response. Note 3: EIRP is based on the highest antenna gain. For MIMO devices refer to KDB Publication 662911 D01.</p>	

Table 3 DFS Response Requirement Values

Parameter	Value
Non-occupancy period	Minimum 30 minutes
Channel Availability Check Time	60 seconds
Channel Move Time	10 seconds See Note 1
Channel Closing Transmission Time	200 milliseconds + an aggregate of 60 milliseconds over remaining 10 second period. See Notes 1 and 2
U-NII Detection Bandwidth	Minimum 100 % of the U-NII 99 % transmission power bandwidth See Note 3
<p>Note 1: Channel Move Time and the Channel Closing Transmission Time should be performed with Radar Type 0. The measurement timing begins at the end of the Radar Type 0 burst. Note 2: The Channel Closing Transmission Time is comprised of 200 milliseconds starting at the beginning of the Channel Move Time plus any additional intermittent control signals required to facilitate a Channel move (an aggregate of 60 milliseconds) during the remainder of the 10 second period. The aggregate duration of control signal will not count quiet periods in between transmissions. Note 3: During the U-NII Detection Bandwidth detection test, radar type 0 should be used. For each frequency step the minimum percentage of detection is 90 percent. Measurements are performed with no data traffic.</p>	

Table 4 Short Pulse Radar Test Waveform

Radar Type	Pulse Width (μsec)	PRI (μsec)	Number of Pulses	Minimum Percentage of Successful Detection	Minimum Number of Trials
0	1	1428	18	See Note 1	See Note 1
1	1	Test A: 15 unique PRI values randomly selected from the list of 23 PRI values in Table 5a	Roundup{(1/360)* (19*10 ⁶ /PRI _{μsec})}	60 %	30
		Test B: 15 unique PRI values randomly selected within the range of 518-3066 μsec, with a minimum increment of 1 μsec, excluding PRI values selected in Test A			
2	1-5	150-230	23-29	60 %	30
3	6-10	200-500	16-18	60 %	30
4	11-20	200-500	12-16	60 %	30
Aggregate (Rader Types 1-4)				80 %	120
Note 1: Short Pulse Radar Type 0 should be used for the detection bandwidth test, channel move time, and channel closing time tests.					

Table 5 Long Pulse Radar Test Waveform

Radar Type	Pulse Width (μsec)	Chip Width (MHz)	PRI (μsec)	Number of Pulses per Burst	Number of Burst	Minimum Percentage of Successful Detection	Minimum Number of Trials
5	50-100	5 - 20	1000-2000	1-3	8-20	80 %	30

Table 6 Frequency Hopping Radar Test Waveform

Radar Type	Pulse Width (μsec)	PRI (μsec)	Pulse per Hop (kHz)	Hopping Rate (kHz)	Hopping Sequence Length (msec)	Minimum Percentage of Successful Detection	Minimum Number of Trials
6	1	333	9	0.333	300	70 %	30

4.3 Test Location

UL Japan, Inc.
Kashima EMC Lab.
1614 Mushihata, Katori-shi, Chiba-ken, 289-0341 JAPAN
Telephone number : +81 478 88 6500
Facsimile number : +81 478 82 3373
A2LA Accreditation No. : 1266-01

	IC Registration No.	Width x Depth x Height (m)	Size of reference ground plane/horizontal conducting plane (m)	Maximum measurement distance
No.1 Open site	IC 4659A-1	6.0 x 5.5 x 2.5	20 x 40	10 m
No.2 Open site	IC 4659A-2	4.4 x 4.4 x 2.15	18 x 20	10 m
No.5 Open site	IC 4659A-5	8.6 x 7.1 x 2.4	18 x 23	10 m
No.1 Shielded room	IC 4659A-1	5.4 x 4.5 x 2.3	-	-
No.2 Shielded room	IC 4659A-2	3.6 x 2.7 x 2.3	-	-
No.3 Shielded room	-	5.4 x 3.6 x 2.3	-	-
No.4 Shielded Room	-	6.1 x 6.1 x 3.1	-	-
No.5 Shielded Room	IC 4659A-5	4.2 x 3.1 x 2.5	-	-
No.3 Fully Anechoic Chamber	-	7.0 x 3.5 x 3.5	-	-
No.6 Semi-anechoic Chamber	IC 4659A-6	8.5 x 5.5 x 5.2	-	3 m
No.10 Semi-anechoic Chamber	IC 4659A-10	18.4 x 9.9 x 7.7	-	10 m
No.11 Semi-anechoic Chamber	IC 4659A-7	9.0 x 6.5 x 5.2	-	3 m
No.1 Measurement room	-	5.0 x 3.7 x 2.6	-	-
No.2 Measurement room	-	4.3 x 4.4 x 2.7	-	-
No.3 Measurement room	-	4.5 x 5.3 x 2.7	-	-

4.4 Uncertainty

The following uncertainties have been calculated to provide a confidence level of 95% using a coverage factor k=2. Time Measurement uncertainty for this test was: (\pm) 0.012%

4.5 Test instruments of DFS, Test set up

Refer to APPENDIX.

SECTION 5: Operation of E.U.T. during testing

5.1 Operating Modes

The EUT, which is a Client Device without Radar detection capability, operates over the 5260 MHz - 5320 MHz and 5500 MHz - 5700 MHz.

The highest EIRP level is 13.18 dBm in the W53 and W56 band.
The highest Power spectral density level is 1.74 dBm/MHz in the W53 and W56 band.

Power level(EIRP) of the EUT[dBm]

5260-5700MHz Band*
Output Power(Max)
13.18

*Refer to 11242579M-C, FCC Part 15E (FCC 15.407) report for other parts than DFS.

The EUT uses one transmitter connected to a 50 ohm coaxial antenna port. The antenna port is connected to the test system.

WLAN traffic is generated by the software to ping from the Master to the Client. That software has random ping intervals. (Channel loading was over 17 %)
Software name & version: ExPing Version 1.33.

The EUT utilizes the 802.11a/n architecture, with a 20MHz channel bandwidth.

The FCC ID for the Master Device used with EUT for DFS testing is LDK102073.

The rated output power of the Master unit is >200 mW(23dBm). Therefore the required interference threshold level is -64 dBm. After correction for antenna gain and procedural adjustments, the required conducted threshold at the antenna port is $-64 + 1 + 0 = -63.0$ dBm (threshold level + additional 1dB + antenna gain).

UL Japan, Inc.

Kashima EMC Lab.

1614, Mushihata, Katori-shi, Chiba-ken, 289-0341 Japan

Telephone: +81-478-88-6500

Facsimile: +81-478-82-3373

5.2 Configuration and peripherals

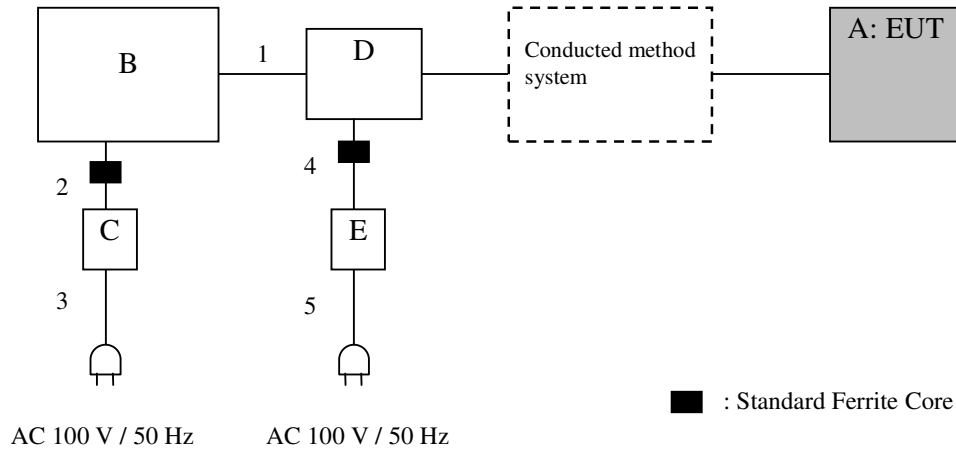

Description of EUT and Support equipment

No.	Item	Model number	Serial number	Manufacturer	Remarks
A	Handheld Terminal	IT-G500-C21E-US	024SE LG6200795IAAD1	CASIO COMPUTER CO., LTD.	EUT
B	PC	VOSTRO 2520	GCKK3Z1	Dell	-
C	AC Adapter	HA65NS5-00	09RN2C	Dell	-
D	Wireless LAN access point (Master Device)	AIR-AP1262N-A-K9	FTX1620K39C	Cisco Systems	-
E	AC Adapter	AA25480L	ALD0652G3EJ	Cisco Systems	-

List of cables used

No.	Name	Length (m)	Shield		Remarks
			Cable	Connector	
1	LAN	2.0	Unshielded	Unshielded	-
2	DC	1.8	Unshielded	Unshielded	-
3	AC	0.9	Unshielded	Unshielded	-
4	DC	1.8	Unshielded	Unshielded	-
5	AC	1.9	Unshielded	Unshielded	-

UL Japan, Inc.

Kashima EMC Lab.

1614, Mushihata, Katori-shi, Chiba-ken, 289-0341 Japan

Telephone: +81-478-88-6500

Facsimile: +81-478-82-3373

5.3 Test and Measurement System

SYSTEM OVERVIEW

The measurement system is based on a conducted test method.

The software selects waveform parameters from within the bounds of the signal type on a random basis using uniform distribution. The short pulse types 2, 3, and 4, the long pulse type 5, and the frequency hopping type 6 parameters are randomized at run-time.

The signal monitoring equipment consists of a spectrum analyzer with the capacity to display 8001 bins on the horizontal axis. A time-domain resolution of 2 msec/bin is achievable with a 16 second sweep time, meeting the 10 seconds short pulse reporting criteria. The aggregate ON time is calculated by multiplying the number of bins above a threshold during a particular observation period by the dwell time per bin, with the analyzer set to peak detection. A time-domain resolution of 3 msec/bin is achievable with a 24 second sweep time, meeting the 22 second long pulse reporting criteria and allowing a minimum of 10 seconds after the end of the long pulse waveform.

FREQUENCY HOPPING RADAR WAVEFORM GENERATING SUBSYSTEM

The first 100 frequencies are selected out of the hopping sequence of the randomized 475 hop frequencies. Only a *Burst* that has the frequency falling within the receiver bandwidth of the tested U-NII device is selected among those frequencies. (Frequency-domain simulation). The radar waveform generated at the start time of the selected *Burst* (Time-domain simulation) is download to the Signal Generator. If all of the randomly selected 100 frequencies do not fall within the receiver bandwidth of the U-NII device, the radar waveform is not used for the test.

CONDUCTED METHODS SYSTEM BLOCK DIAGRAM

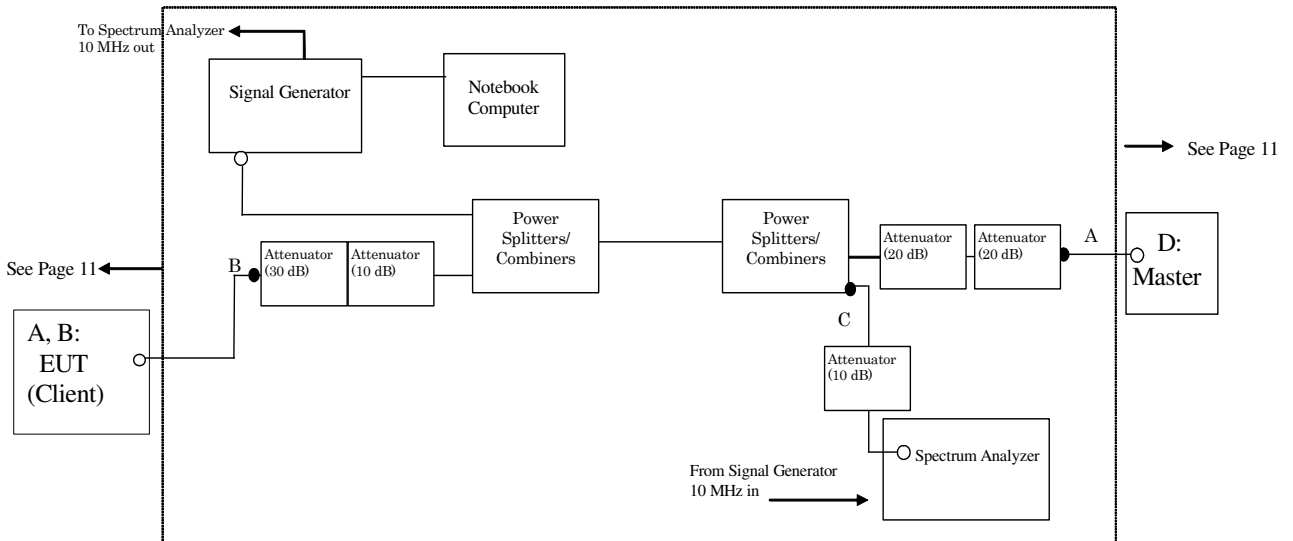

MEASUREMENT SYSTEM FREQUENCY REFERENCE

Lock the signal generator and the spectrum analyzer to the same reference sources as follows: Connect the 10 MHz OUT on the signal generator to the EXT REF IN on the spectrum analyzer and set the spectrum analyzer Ext to On.

UL Japan, Inc.

Kashima EMC Lab.

1614, Mushihata, Katori-shi, Chiba-ken, 289-0341 Japan

Telephone: +81-478-88-6500

Facsimile: +81-478-82-3373

SYSTEM CALIBRATION

Step 1: Set the system as shown in Figure 3 of KDB905462 7.2.2.

Step 2: Adjust each attenuator to fulfill the following three conditions:

- WLAN can be communicated, and
- Rader detection threshold level is bigger than Client Device traffic level on the spectrum analyzer, and
- Master Device traffic level is not displayed on the spectrum analyzer.

Step 3: Terminate 50 ohm at B and C points, and connect the spectrum analyzer to the point A.

(See the figure on page 12)

At the point A, adjust the signal generator and spectrum analyzer to the center frequency of the channel to be measured.

Download the applicable radar waveforms to the signal generator. Select the radar waveform, trigger a burst manually and measure the amplitude on the spectrum analyzer. Readjust the amplitude of the signal generator as required so that the peak level of the waveform is at a displayed level equal to the required or desired interference detection threshold.

Separate signal generator amplitude settings are determined as required for each radar type.

Step 4: Without changing any of the instrument settings, restore the system setting to Step 2 and adjust the Reference Level Offset of the spectrum analyzer to the level at Step 3.

By taking the above steps 1 to 4, the spectrum analyzer displays the level of the signal generator as received at the antenna ports of the Master Device.

See Clause 5.4 for Plots of Noise, Rader Waveforms, and WLAN signals.

5.4 Plots of Noise, Rader Waveforms, and WLAN signals

Plots of System Noise Floor

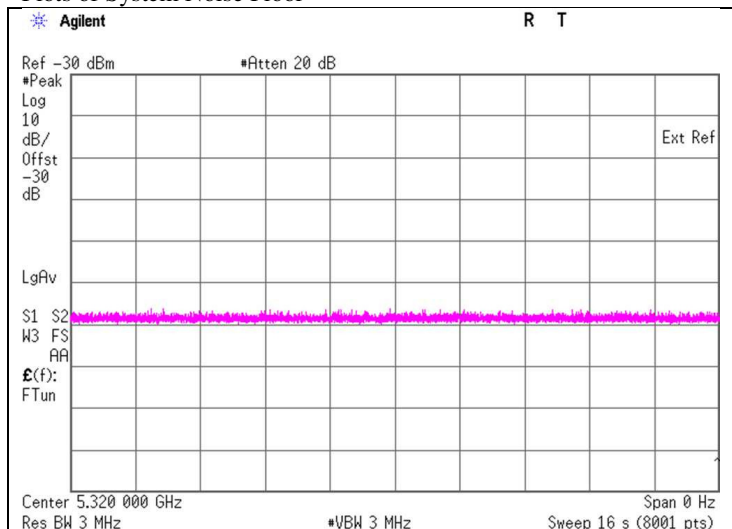

UL Japan, Inc.

Kashima EMC Lab.

1614, Mushihata, Katori-shi, Chiba-ken, 289-0341 Japan

Telephone: +81-478-88-6500

Facsimile: +81-478-82-3373

Plots of Radar Waveforms

Rader Type 1

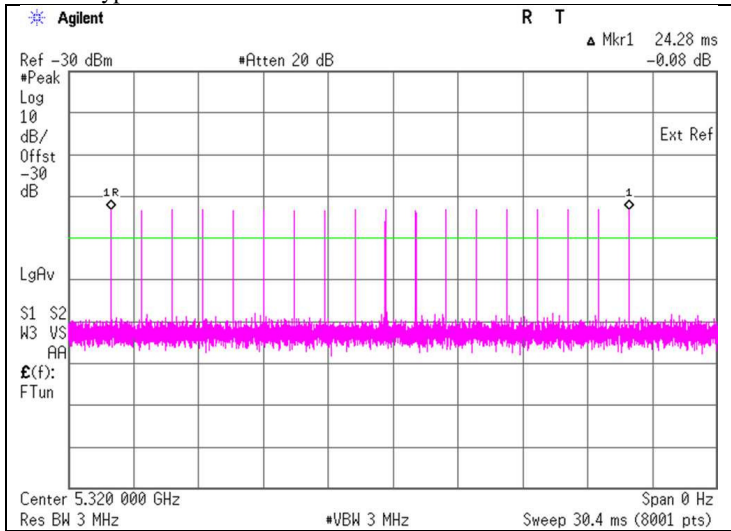

Plots of WLAN Traffic

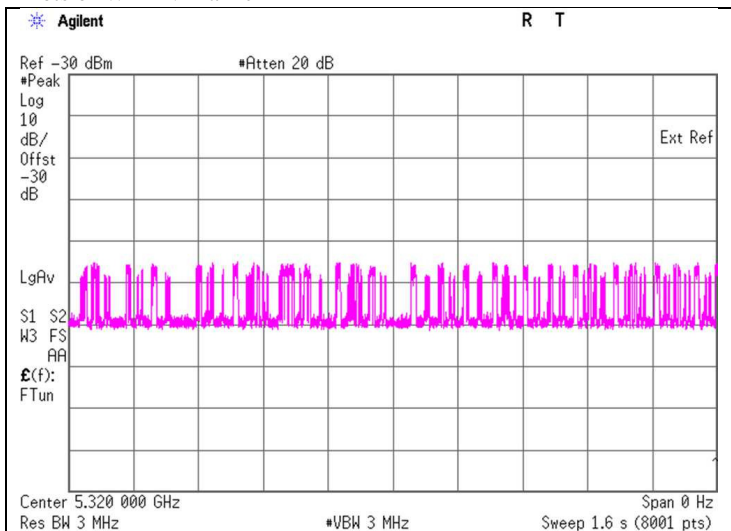

UL Japan, Inc.

Kashima EMC Lab.

1614, Mushihata, Katori-shi, Chiba-ken, 289-0341 Japan

Telephone: +81-478-88-6500

Facsimile: +81-478-82-3373

SECTION 6: Channel Move Time, Channel Closing Transmission Time

6.1 Operating environment

Test place : No.2 measurement room
Temperature : 21 deg. C
Humidity : 48 % RH

6.2 Test Procedure

Transfer files from the Master Device to the Client Device on the test Channel for the entire period of the test. The Radar Waveform generator sends a Burst of pulses for one of the Short Pulse Radar Types 0 at levels defined , on the Operating Channel. An additional 1 dB is added to the radar test signal to ensure it is at or above the DFS Detection Threshold, accounting for equipment variations/errors. Observe the transmissions of the EUT at the end of the radar Burst on the Operating Channel for duration greater than 10 seconds.

6.3 Test data

Test Item	Unit	Measurement Time	Limit	Results
Channel Move Time *1)	[sec]	0.032	10.000	Pass
Channel Closing Transmission Time *2)	[msec]	4	60	Pass

*1) Channel Move Time is calculated as follows:

$$(\text{Channel Move Time}) = (\text{End of Transmission}) - (\text{End of Burst}) = 0.900 - 0.868$$

*2) Channel Closing Transmission Time is calculated from (End of Burst + 200 msec) to (End of Burst + 10 sec)

$$\begin{aligned}(\text{Channel Closing Transmission Time}) &= (\text{Number of analyzer bins showing transmission}) * (\text{dwell time per bin}) \\ &= 2 * 2(\text{msec})\end{aligned}$$

UL Japan, Inc.

Kashima EMC Lab.

1614, Mushihata, Katori-shi, Chiba-ken, 289-0341 Japan

Telephone: +81-478-88-6500

Facsimile: +81-478-82-3373

Radar Type 1

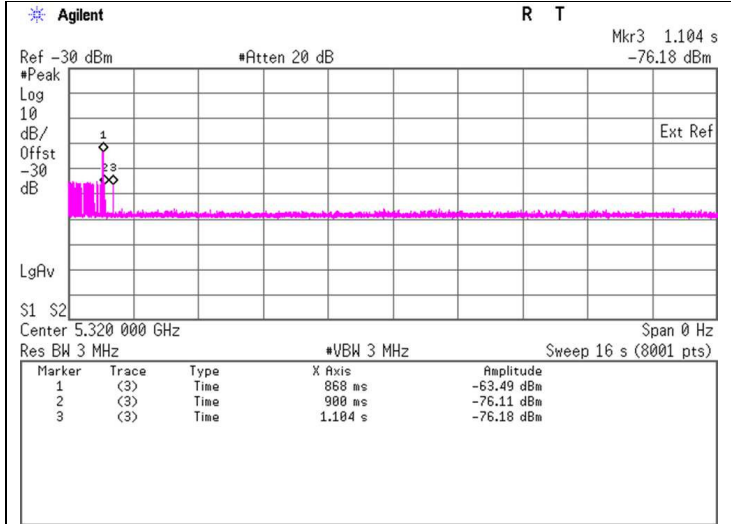

Marker 1 : End of Burst : 868 ms
Marker 2 : End of Transmission : 900 ms

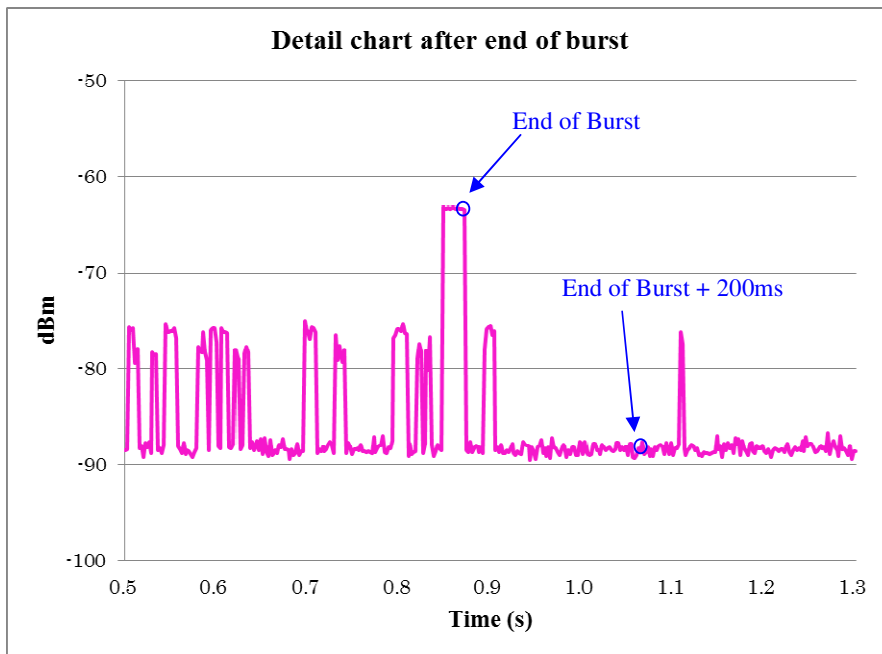

6.4 Test result

Test result: Pass

Date : June 6, 2016

Test engineer : Kazuhiro Ando

UL Japan, Inc.

Kashima EMC Lab.

1614, Mushihata, Katori-shi, Chiba-ken, 289-0341 Japan

Telephone: +81-478-88-6500

Facsimile: +81-478-82-3373

SECTION 7: Non-Occupancy Period

7.1 Operating environment

Test place : No.2 measurement room
 Temperature : 21 deg. C
 Humidity : 48 % RH

7.2 Test Procedure

The following two tests are performed:

1). Transfer files from the Master Device to the Client Device on the test Channel for the entire period of the test. The Radar Waveform generator sends a Burst of pulses for one of the Radar Types 0 at levels defined on the Operating Channel. An additional 1 dB is added to the radar test signal to ensure it is at or above the DFS Detection Threshold, accounting for equipment variations/errors. Observe the transmissions of the EUT after the Channel Move Time on the Operating Channel for duration greater than 30 minutes.

2). Transfer files from the Master Device to the Client Device on the test Channel for the entire period of the test. Observe the transmissions of the EUT on the Operating Channel for duration greater than 30 minutes after the Master Device is shut off.

7.3 Test data

1). Non-Occupancy Period

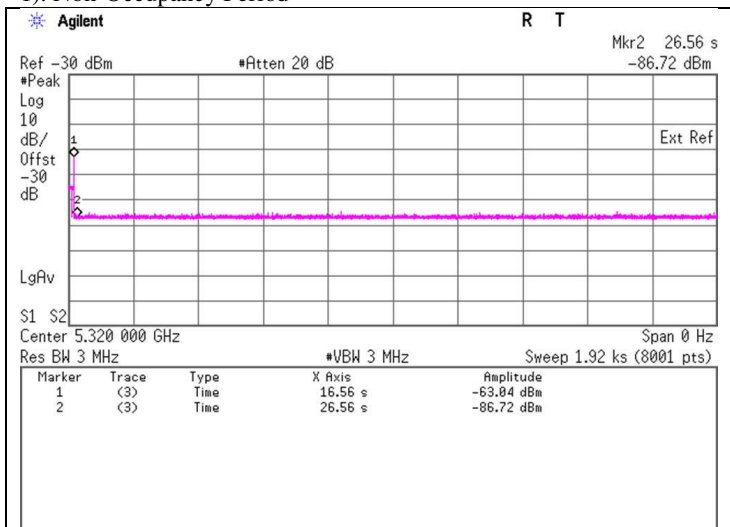

Marker 1 : End of Burst : 16.56 sec
Marker 2 : End of Burst +10sec : 26.56 sec

UL Japan, Inc.

Kashima EMC Lab.

1614, Mushihata, Katori-shi, Chiba-ken, 289-0341 Japan

Telephone: +81-478-88-6500

Facsimile: +81-478-82-3373

2). Master is shut off

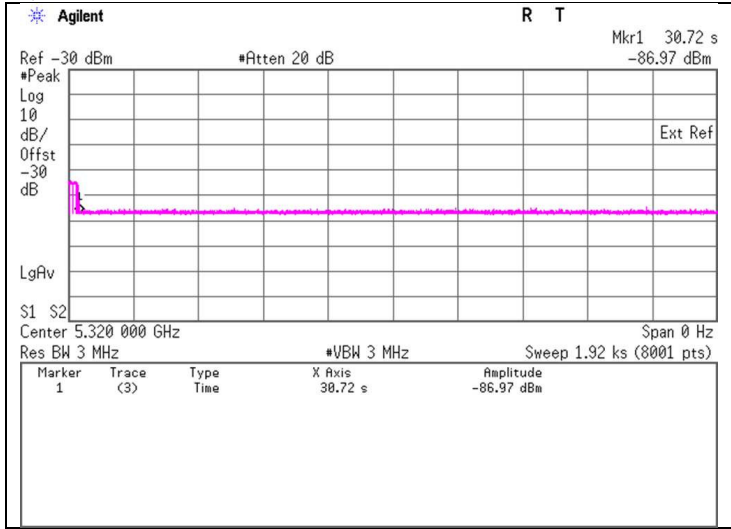

7.4 Test result

Test result: Pass

Date : June 6, 2016

Test engineer : Kazuhiro Ando

UL Japan, Inc.

Kashima EMC Lab.

1614, Mushihata, Katori-shi, Chiba-ken, 289-0341 Japan

Telephone: +81-478-88-6500

Facsimile: +81-478-82-3373

APPENDIX 1: Test instruments

Test equipment

Control No.	Instrument	Manufacturer	Model No	Serial No	Test Item	Calibration Date * Interval(month)
CSA-07	Spectrum Analyzer	Agilent	E4448A	MY52490024 Version A.11.21	DFS	2016/05/11 * 12
CSG-12	Signal Generator	Agilent	N5182B	MY53050599 Version B.01.50	DFS	2016/05/12 * 12
CPSC-02	Power Splitters /Combiners	Mini-Circuits	ZFSC-2-10G+	-	DFS	2015/06/01 * 12
CPSC-03	Power Splitters /Combiners	Mini-Circuits	ZFSC-2-10G+	-	DFS	2015/06/01 * 12
CAT10-16	10dB Fixed Atten.	Weinschel	54A-10	56246	DFS	2016/05/13 * 12
CAT10-17	10dB Fixed Atten.	Weinschel	54A-10	56251	DFS	2016/05/13 * 12
CAT20-05	20dB Fixed Atten.	Weinschel	54A-20	42054	DFS	2016/05/13 * 12
CAT20-06	20dB Fixed Atten.	TAMAGAWA	CFA-01	-	DFS	-
CAT30-02	30dB Fixed Atten.	Agilent	8493C-030	71675	DFS	2016/05/09 * 12
CCC-W01	Micro Wave Cable	SUHNER	SUCOFLEX102	MY3662/2	DFS	2016/05/13 * 12
CCC-W06	Micro Wave Cable	Junkosha	MWX241	MRA-12-14-146	DFS	2016/05/12 * 12
CCC-W13	Micro Wave Cable	RINEI SEIKI	RG174/U	none	DFS	Pre Check
CCC-W14	Micro Wave Cable	Suhner	SUCOFLEX104PE	36186	DFS	Pre Check

**The expiration date of the calibration is the end of the expired month.
All equipment is calibrated with valid calibrations. Each measurement data is traceable to the national or international standards.**

As for some calibrations performed after the tested dates, those test equipment have been controlled by means of an unbroken chains of calibrations.

DFS: Dynamic Frequency Selection