



RADIO TEST REPORT

Test Report No. : 11242579M-B

Applicant : CASIO COMPUTER CO., LTD.
Type of Equipment : Handheld Terminal
Model No. : IT-G500-C21E-US
FCC ID : BBQITG500
Test regulation : FCC Part 15 Subpart C: 2016
(Bluetooth part)
Test Result : Complied

1. This test report shall not be reproduced in full or partial, without the written approval of UL Japan, Inc.
2. The results in this report apply only to the sample tested.
3. This sample tested is in compliance with the above regulation.
4. The test results in this report are traceable to the national or international standards.
5. The opinions and the interpretations to the result of the description in this report are outside scopes where UL Japan has been accredited.
6. This test report covers Radio technical requirements. It does not cover administrative issues such as Manual or non-Radio test related Requirements. (if applicable)

Date of test: April 27-29, May 9, 10, 25, 26, 2016

Representative test engineer:

Kazuhiro Ando
Engineer
Consumer Technology Division

Approved by:

Masanori Nishiyama
Manager
Consumer Technology Division



CERTIFICATE 1266.01

- The testing in which "Non-accreditation" is displayed is outside the accreditation scopes in UL Japan.
 There is no testing item of "Non-accreditation".

UL Japan, Inc.

Kashima EMC Lab.

1614, Mushiata, Katori-shi, Chiba-ken, 289-0341 Japan

Telephone : +81-478-88-6500

Facsimile : +81-478-82-3373

REVISION HISTORY

Original Test Report No.: 11242579M-B

Revision	Test report No.	Date	Page revised	Contents
- (Original)	11242579M-B	June 17, 2016	-	-
1	11242579M-B	June 27, 2016	P.10	Add a description of supported equipment

CONTENTS	PAGE
SECTION 1: Customer information.....	4
SECTION 2: Equipment under test (E.U.T.).....	4
SECTION 3: Test specification, procedures & results.....	6
SECTION 4: Operation of E.U.T. during testing.....	9
SECTION 5: Conducted Emission.....	12
SECTION 6: Radiated Spurious Emission	13
SECTION 7: Antenna Terminal Conducted Tests.....	14
APPENDIX 1: Test data	15
Conducted Emission	15
20dB Bandwidth and Carrier Frequency Separation.....	23
Number of Hopping Frequency	26
Dwell time.....	28
Maximum Peak Output Power.....	31
Average Output Power.....	32
Radiated Spurious Emission	34
Conducted Spurious Emission	45
Conducted Emission Band Edge compliance	51
99%Occupied Bandwidth	53
APPENDIX 2: Test instruments	55
APPENDIX 3: Photographs of test setup	57
Conducted Emission	57
Radiated Spurious Emission	59
Worst Case Position	60

SECTION 1: Customer information

Company Name : CASIO COMPUTER CO., LTD.
Address : 2951-5, Ishikawa-Machi, Hachioji-shi Tokyo 192-8556, Japan
Telephone Number : +81-42-639-5188
Facsimile Number : +81-42-639-5046
Contact Person : KATSUMASA MOTOKI

SECTION 2: Equipment under test (E.U.T.)

2.1 Identification of E.U.T.

Type of Equipment : Handheld Terminal
Model No. : IT-G500-C21E-US
Serial No. : Refer to Section 4, Clause 4.2
Rating : Li-ion battery DC3.7V 1850mAh/6.9Wh, M/N:HA-D20BAT-A
Option Battery : Li-ion battery DC3.7V 3700mAh/14Wh, M/N:HA-D21LBAT-A
Receipt Date of Sample : April 18, 2016
Country of Mass-production : Japan
Condition of EUT : Production prototype
(Not for Sale: This sample is equivalent to mass-produced items.)
Modification of EUT : No Modification by the test lab

2.2 Product Description

Model: IT-G500-C21E-US (referred to as the EUT in this report) is a Handheld Terminal.

General Specification

Clock frequency(ies) in the system	CPU: 1.5 GHz
Power Supply (inner)	DC 3.3 V / 1.8 V

UL Japan, Inc.

Kashima EMC Lab.

1614, Mushiata, Katori-shi, Chiba-ken, 289-0341 Japan

Telephone : +81-478-88-6500

Facsimile : +81-478-82-3373

Radio Specification

WLAN (IEEE802.11b/g/a/n-20)

Equipment Type	Transceiver
Frequency of Operation	2412-2462MHz, 5180-5825MHz
Type of Modulation	DSSS, OFDM
Antenna type	Inverted F antenna (IEEE802.11b/g/n) Dipole antenna (IEEE802.11a/n)
Antenna Gain	0.79dBi (2412-2462MHz) 1.05dBi (5180-5825MHz)

BT

Equipment Type	Transceiver
Frequency of Operation	2402-2480MHz
Type of Modulation	FHSS
Antenna type	Inverted F antenna
Antenna Gain	0.79dBi

RFID

Equipment Type	Transceiver
Frequency of Operation	13.56MHz
Type of Modulation	ASK
Antenna type	Loop antenna

- * Refer to the test reports: 11242579M-A for 2.4 GHz band (Wireless LAN part).
- * Refer to the test reports: 11242579M-C and 11242579M-D for 5 GHz band.
- * Refer to the test reports: 11242579M-E for 13.56 MHz band (RFID).

SECTION 3: Test specification, procedures & results

3.1 Test Specification

Test Specification : FCC Part 15 Subpart C.
FCC part 15 final revised on April 6, 2016.

Title : FCC 47CFR Part15 Radio Frequency Device Subpart C Intentional Radiators
Section 15.207 Conducted limits
Section 15.247 Operation within the bands 902-928MHz,
2400-2483.5MHz, and 5725-5850MHz

* The revision on April 6, 2016, does not affect the test specification applied to the EUT.
* Also the EUT complies with FCC Part 15 Subpart B.

3.2 Procedures and results

Item	Test Procedure	Specification	Worst Margin	Results	Remarks	
Conducted Emission	FCC: ANSI C63.10-2013 6. Standard test methods	FCC: Section 15.207	QP 14.3 dB, 0.48873 MHz, L AV 9.8 dB, 0.50000 MHz, N	Complied	-	
	IC: RSS-Gen 8.8	IC: RSS-Gen 8.8				
Carrier Frequency Separation	FCC: FCC Public Notice DA 00-705	FCC: Section15.247(a)(1)	See data.	Complied	Conducted	
	IC: -	IC: RSS-247 5.1 (2)				
20dB Bandwidth	FCC: FCC Public Notice DA 00-705	FCC: Section15.247(a)(1)		-	-	Conducted
	IC: -	IC: RSS-247 5.1 (1)				
Number of Hopping Frequency	FCC: FCC Public Notice DA 00-705	FCC: Section15.247(a)(1)(iii)		Complied	Complied	Conducted
	IC: -	IC: RSS-247 5.1 (4)				
Dwell time	FCC: FCC Public Notice DA 00-705	FCC: Section15.247(a)(1)(iii)		Complied	Complied	Conducted
	IC: -	IC: RSS-247 5.1 (4)				
Maximum Peak Output Power	FCC: FCC Public Notice DA 00-705	FCC: Section15.247(a)(b)(1)	Complied	Complied	Conducted	
	IC: RSS-Gen 6.12	IC: RSS-247 5.4 (2)				
Spurious Emission & Band Edge Compliance	FCC: FCC Public Notice DA 00-705 IC: RSS-Gen 6.13	FCC: Section15.247(d) IC: RSS-247 5.5 RSS-Gen 8.9 RSS-Gen 8.10	3.9 dB 4882.000 MHz, AV, Vert.	Complied	Conducted/ Radiated (above 30 MHz) *1)	

Note: UL Japan, Inc.'s EMI Work Procedures No. 13-EM-W0420 and 13-EM-W0422.

*1) Radiated test was selected over 30 MHz based on section 15.247(d).

* In case any questions arise about test procedure, ANSI C63.10: 2013 is also referred.

FCC Part 15.31 (e)

This EUT provides stable voltage (DC 1.8V) constantly to RF Part regardless of input voltage. Therefore, this EUT complies with the requirement.

FCC Part 15.203 Antenna requirement

It is impossible for end users to replace the antenna, because the antenna is mounted inside of the EUT. Therefore, the equipment complies with the antenna requirement of Section 15.203.

UL Japan, Inc.

Kashima EMC Lab.

1614, Mushihata, Katori-shi, Chiba-ken, 289-0341 Japan

Telephone : +81-478-88-6500

Facsimile : +81-478-82-3373

3.3 Addition to standard

Item	Test Procedure	Specification	Worst margin	Results	Remarks
99% Occupied Bandwidth	IC: RSS-Gen 6.6	IC: -	N/A	-	Conducted

Other than above, no addition, exclusion nor deviation has been made from the standard.

3.4 Uncertainty

EMI

The following uncertainties have been calculated to provide a confidence level of 95 % using a coverage factor $k = 2$.

Item	Frequency range	Uncertainty (+/-)
		No. 1 SAC / SR
Radiated emission (Measurement distance: 3m)	30MHz - 300MHz	4.7dB
	300MHz - 1GHz	3.6dB
	1GHz - 10GHz	5.1dB
Radiated emission (Measurement distance: 1m)	10GHz - 18GHz	5.7dB
	18GHz - 26.5GHz	5.1dB

Antenna terminal test	Uncertainty (+/-)
Power Measurement above 1GHz	0.7dB
Spurious emission (Conducted) below 1GHz	1.6dB
Spurious emission (Conducted) 1GHz - 3GHz	1.4dB
Spurious emission (Conducted) 3GHz - 18GHz	2.8dB
Spurious emission (Conducted) 18GHz - 26.5GHz	2.5dB
Bandwidth Measurement	5.4%

Conducted Emission test

The data listed in this test report has enough margin, more than the site margin.

Radiated emission test

The data listed in this report meets the limits unless the uncertainty is taken into consideration.

3.5 Test Location

UL Japan, Inc. Kashima EMC Lab.
1614 Mushihata, Katori-shi, Chiba-ken, 289-0341 JAPAN
Telephone: +81 478 88 6500, Facsimile: +81 478 82 3373
A2LA Accreditation No. 1266.01

Test site	IC Registration Number	Width x Depth x Height (m)	Size of reference ground plane (m) / horizontal conducting plane	Maximum measurement distance
No.1 Open site	4659A-1	6.0 x 5.5 x 2.5	20 x 40	10 m
No.2 Open site	4659A-2	4.4 x 4.4 x 2.15	18 x 20	10 m
No.5 Open site	4659A-5	8.6 x 7.1 x 2.4	18 x 23	10 m
No.1 Shielded room	4659A-1	5.4 x 4.5 x 2.3	-	-
No.2 Shielded room	4659A-2	3.6 x 2.7 x 2.3	-	-
No.3 Shielded room	-	5.4 x 3.6 x 2.3	-	-
No.4 Shielded Room	-	6.1 x 6.1 x 3.1	-	-
No.5 Shielded Room	4659A-5	4.2 x 3.1 x 2.5	-	-
No.3 Fully Anechoic Chamber	-	7.0 x 3.5 x 3.5	-	-
No.6 Semi-anechoic Chamber	4659A-6	8.5 x 5.5 x 5.2	-	3 m
No.10 Semi-anechoic Chamber	4659A-10	18.4 x 9.9 x 7.7	-	10 m
No.11 Semi-anechoic Chamber	4659A-7	9.0 x 6.5 x 5.2	-	3 m
No.1 Measurement room	-	5.0 x 3.7 x 2.6	-	-
No.2 Measurement room	-	4.3 x 4.4 x 2.7	-	-
No.3 Measurement room	-	4.3 x 4.4 x 2.7	-	-

3.6 Test data, Test instruments, and Test set up

Refer to APPENDIX.

SECTION 4: Operation of E.U.T. during testing

4.1 Operating Mode(s)

Bluetooth (BT): Transmitting (Tx), Payload: PRBS9

Details of Operating Mode(s)

Test Item	Mode	Tested frequency
Conducted Emission, Spurious Emission (Conducted/Radiated)	Tx (Hopping Off) DH5, 3DH5	2402 MHz 2441 MHz 2480 MHz
Carrier Frequency Separation	Tx (Hopping Off) DH5, 3DH5	2402 MHz 2441 MHz 2480 MHz
20dB Bandwidth	Tx (Hopping Off) DH5, 3DH5	2402 MHz 2441 MHz 2480 MHz
Number of Hopping Frequency	Tx (Hopping On) DH5, 3DH5	-
Dwell time	Tx (Hopping On), -DH1, DH3, DH5 -3DH1, 3DH3, 3DH5	-
Maximum Peak Output Power	Tx (Hopping Off) DH5, 2DH5, 3DH5	2402 MHz 2441 MHz 2480 MHz
Band Edge Compliance (Conducted)	Tx DH5, 3DH5 -Hopping On -Hopping Off	2402 MHz 2480 MHz
99% Occupied Bandwidth	Tx DH5, 3DH5 -Hopping On -Hopping Off	2402 MHz 2441 MHz 2480 MHz
<p>*As a result of preliminary test, the formal test was performed with the above modes, which had the maximum payload length (except Dwell time test) *2DH mode (2Mb/s EDR: pi/4DQPSK) was excluded for other tests than power measurement by using 3DH mode (3 Mb/s EDR: 8DPSK) as a representative. * It is considered that the non-tested packet type (e.g. inquiry) can be omitted as it is complied with above all the test items based on Bluetooth Core specification.</p> <p>*EUT has the power settings by the software as follows; Power settings: 15 Software: WL127X_BTTOOL</p> <p>*This setting of software is the worst case. Any conditions under the normal use do not exceed the condition of setting. In addition, end users cannot change the settings of the output power of the product.</p>		

UL Japan, Inc.

Kashima EMC Lab.

1614, Mushihata, Katori-shi, Chiba-ken, 289-0341 Japan

Telephone : +81-478-88-6500

Facsimile : +81-478-82-3373

4.2 Configuration and peripherals

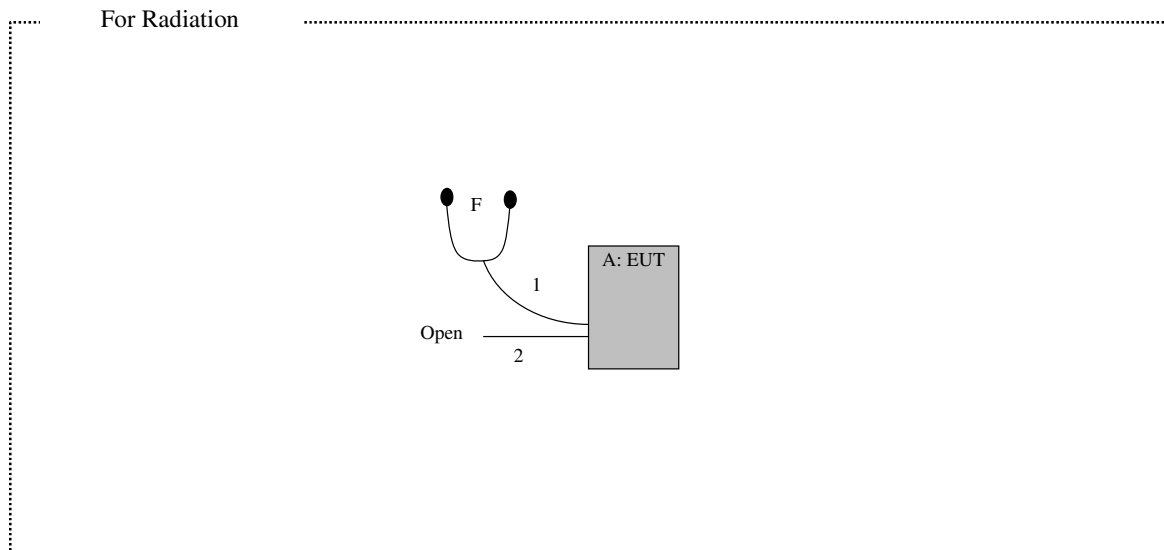
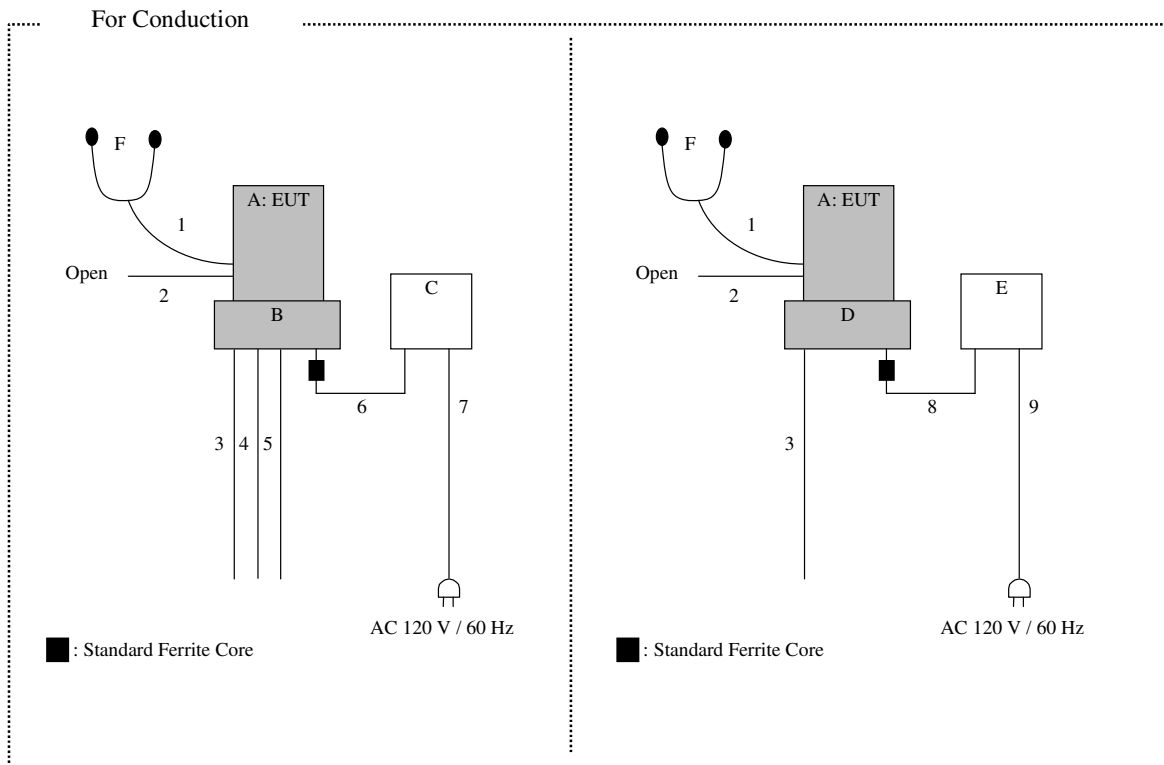

* Cabling and setup(s) were taken into consideration and test data was taken under worse case conditions.

Description of EUT and Support equipment

No.	Item	Model number	Serial number	Manufacturer	Remarks
A	Handheld Terminal	IT-G500-C21E-US	024SE LG6200795IAAD1 *1) 024SE LG6100692IAAC1 *2)	CASIO COMPUTER CO., LTD.	EUT
B	Cradle	HA-P62IO	244AA JX4B00502 GAAA1	CASIO COMPUTER CO., LTD.	EUT
C	AC Adapter	AD-S42120C	0915C	CASIO COMPUTER CO., LTD.	-
D	Cradle	HA-P60IO	241AA JW4B00501 GAAA1	CASIO COMPUTER CO., LTD.	EUT
E	AC Adapter	AD-S15050B	0711C	CASIO COMPUTER CO., LTD.	-
F	Ear phone	-	-	-	-

*1) Used for Antenna Terminal conducted tests

*2) Used for Conducted Emission test and Radiated Spurious Emission tests

List of cables used

No.	Name	Length (m)	Shield		Remarks
			Cable	Connector	
1	Ear phone	1.2	Unshielded	Unshielded	-
2	USB	1.8	Shielded	Shielded	-
3	USB	1.8	Shielded	Shielded	-
4	USB	2.0	Shielded	Shielded	-
5	LAN	1.0	Unshielded	Unshielded	-
6	DC	1.5	Unshielded	Unshielded	-
7	AC	2.0	Unshielded	Unshielded	-
8	DC	1.5	Unshielded	Unshielded	-
9	AC	2.0	Unshielded	Unshielded	-

UL Japan, Inc.

Kashima EMC Lab.

1614, Mushihata, Katori-shi, Chiba-ken, 289-0341 Japan

Telephone : +81-478-88-6500

Facsimile : +81-478-82-3373

SECTION 5: Conducted Emission

Test Procedure and conditions

EUT was placed on a wooden table of nominal size, 1.0 m by 2.0 m, raised 0.8m above the conducting ground plane. The rear of tabletop was located 40 cm to the vertical conducting plane. The rear of EUT, including peripherals aligned and flushed with rear of tabletop. All other surfaces of tabletop were at least 80 cm from any other grounded conducting surface. EUT was located 80 cm from a Line Impedance Stabilization Network (LISN) / Artificial mains Network (AMN) and excess AC cable was bundled in center.

I/O cables that were connected to the peripherals were bundled in center. They were folded back and forth forming a bundle 30 cm to 40 cm long and were hanged at a 40 cm height to the ground plane.

The AC Mains Terminal Continuous disturbance Voltage has been measured with the EUT in a Semi Anechoic Chamber.

The EUT was connected to a LISN (AMN).

An overview sweep with peak detection has been performed.

The test results and limit are rounded off to one decimal place, so some differences might be observed.

Detector : QP and CISPR AV
Measurement range : 0.15 MHz - 30 MHz
Test data : APPENDIX
Test result : Pass

SECTION 6: Radiated Spurious Emission

Test Procedure

[For below 1GHz]

EUT was placed on a urethane platform of nominal size, 0.5 m by 0.5 m, raised 0.8 m above the conducting ground plane. The Radiated Electric Field Strength has been measured in a Semi Anechoic Chamber with a ground plane.

[For above 1GHz]

EUT was placed on a urethane platform of nominal size, 0.5 m by 0.5 m, raised 1.5 m above the conducting ground plane.

The Radiated Electric Field Strength has been measured in a Semi Anechoic Chamber with absorbent materials lined on a ground plane.

The height of the measuring antenna varied between 1 and 4 m and EUT was rotated a full revolution in order to obtain the maximum value of the electric field strength.

The measurements were performed for both vertical and horizontal antenna polarization with the Test Receiver, or the Spectrum Analyzer.

The measurements were made with the following detector function of the test receiver and the Spectrum analyzer (in linear mode).

The test was made with the detector (RBW/VBW) in the following table.

When using Spectrum analyzer, the test was made with adjusting span to zero by using peak hold.

Test Antennas are used as below;

Frequency	Below 1 GHz	Above 1 GHz
Antenna Type	Hybrid	Horn

In any 100 kHz bandwidth outside the restricted band in which the spread spectrum intentional radiator is operating, the radio frequency power that is produced by the intentional radiator confirmed 20 dB below that in the 100 kHz bandwidth within the band that contains the highest level of the desired power, based on a radiated measurement.

20 dBc was applied to the frequency over the limit of FCC 15.209 / Table 4 of RSS-Gen 8.9 (IC) and outside the restricted band of FCC15.205 / Table 6 of RSS-Gen 8.10 (IC).

Frequency	Below 1 GHz	Above 1 GHz		20 dBc
Instrument used	Test Receiver	Spectrum Analyzer		Spectrum Analyzer
Detector	QP	PK	AV	PK
IF Bandwidth	BW 120 kHz	RBW: 1 MHz VBW: 3 MHz	RBW: 1 MHz VBW: 10 Hz *1)	RBW: 100 kHz VBW: 300 kHz
Test Distance	3.0 m	4.5 m*2) (1 GHz – 10 GHz), 1.0 m*3) (10 GHz – 26.5 GHz),		4.5 m*2) (1 GHz – 10 GHz), 1.0 m*3) (10 GHz – 26.5 GHz),

*1) Although DA 00-705 accepts VBW = 10 Hz for AV measurements, it was confirmed that superfluous smoothing was not performed.

*2) Distance Factor: $20 \times \log(4.5 \text{ m}/3.0 \text{ m}) = 3.5 \text{ dB}$

*3) Distance Factor: $20 \times \log(1.0 \text{ m}/3.0 \text{ m}) = -9.5 \text{ dB}$

- The carrier level and noise levels were confirmed at each position of X, Y and Z axes of EUT and EUT on the cradle to see the position of maximum noise, and the test was made at the position that has the maximum noise.

The test results and limit are rounded off to one decimal place, so some differences might be observed.

Measurement range : 30 MHz - 26.5 GHz

Test data : APPENDIX

Test result : Pass

UL Japan, Inc.

Kashima EMC Lab.

1614, Mushihata, Katori-shi, Chiba-ken, 289-0341 Japan

Telephone : +81-478-88-6500

Facsimile : +81-478-82-3373

SECTION 7: Antenna Terminal Conducted Tests

Test Procedure

The tests were made with below setting connected to the antenna port.

Test	Span	RBW	VBW	Sweep time	Detector	Trace	Instrument used
20dB Bandwidth	3 MHz	30 kHz	100 kHz	Auto	Peak	Max Hold	Spectrum Analyzer
99% Occupied Bandwidth *1)	Enough width to display emission skirts	1 to 5 % of OBW	Three times of RBW	Auto	Peak	Max Hold	Spectrum Analyzer
Maximum Peak Output Power	-	-	-	Auto	Peak Average *3)	-	Power Meter (Sensor: 50MHz BW)
Carrier Frequency Separation	3 MHz	100 kHz	300 kHz	Auto	Peak	Max Hold	Spectrum Analyzer
Number of Hopping Frequency	30 MHz	300 kHz	1 MHz	Auto	Peak	Max Hold	Spectrum Analyzer
Dwell Time	Zero Span	100 kHz, 1 MHz	300 kHz, 3 MHz	As necessary capture the entire dwell time per hopping channel	Peak	Clear Write	Spectrum Analyzer
Conducted Spurious Emission *2)	9 kHz to 150 kHz	200 Hz	620 Hz	Auto	Peak	Max Hold	Spectrum Analyzer
	150 kHz to 30 MHz	10 kHz	30 kHz				
	30 MHz to 25 GHz	100 kHz	300 kHz				
Conducted Spurious Emission Band Edge compliance	10 MHz	100 kHz	300 kHz	Auto	Peak	Max Hold	Spectrum Analyzer

*1) Peak hold was applied as Worst-case measurement.

*2) In the frequency range below 30MHz, RBW was narrowed to separate the noise contents. Then, wide-band noise near the limit was checked separately; however the noise was not detected as shown in the chart. (9 kHz -150 kHz: RBW = 200 Hz, 150 kHz - 30 MHz: RBW = 10 kHz)

*3) Reference data

The test results and limit are rounded off to two decimals place, so some differences might be observed.

Test data : APPENDIX

Test result : Pass

APPENDIX 1: Test data

Conducted Emission
(With Cradle: HA-P62IO)

DATA OF CONDUCTED EMISSION TEST

UL Japan, Inc. Kashima EMC Lab. No.2 Shielded Room
Date : 2016/05/26

Mode : Tx, DH5, 2402MHz
Order No. : 11242579M
Power : AC 120V / 60Hz
Temp./Humi. : 22deg.C / 59%RH

Limit1 : FCC 15C (15.207) ClassB QP
Limit2 : FCC 15C (15.207) ClassB AV

Tested by : Kazuhiro Ando

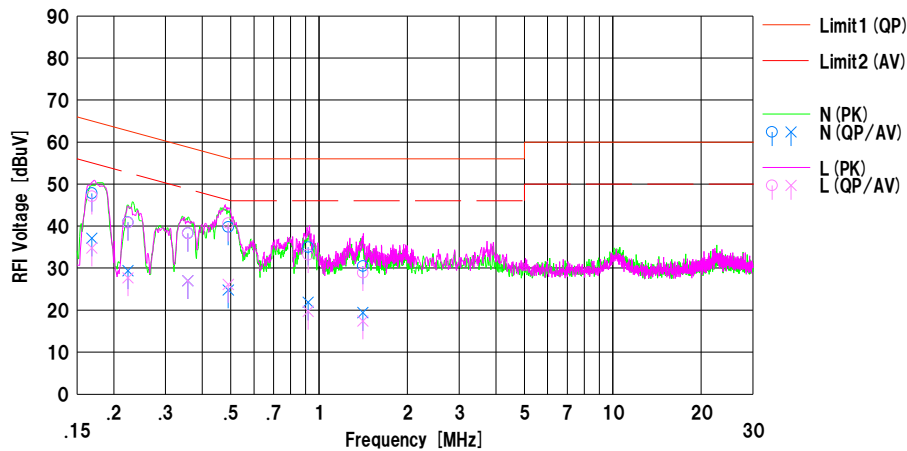

No.	Freq. [MHz]	Reading		C.Fac [dB]	Results		Limit		Margin		Phase	Comment
		<QP> [dBuV]	<AV> [dBuV]		<QP> [dBuV]	<AV> [dBuV]	<QP> [dBuV]	<AV> [dBuV]	<QP> [dB]	<AV> [dB]		
1	0.16845	38.1	27.4	9.7	47.8	37.1	65.0	55.0	17.2	-17.9	N	
2	0.22333	31.2	19.7	9.7	40.9	29.4	62.7	52.7	21.8	-23.3	N	
3	0.35763	28.6	17.3	9.7	38.3	27.0	58.8	48.8	20.5	-21.8	N	
4	0.49075	30.1	15.1	9.7	39.8	24.8	56.2	46.2	16.4	-21.4	N	
5	0.91720	25.3	12.2	9.7	35.0	21.9	56.0	46.0	21.0	-24.1	N	
6	1.40996	20.7	9.6	9.8	30.5	19.4	56.0	46.0	25.5	-26.6	N	
7	0.16845	37.4	25.1	9.7	47.1	34.8	65.0	55.0	17.9	-20.2	L	
8	0.22333	31.1	18.0	9.7	40.8	27.7	62.7	52.7	21.9	-25.0	L	
9	0.35763	28.6	17.3	9.7	38.3	27.0	58.8	48.8	20.5	-21.8	L	
10	0.49075	31.0	16.4	9.7	40.7	26.1	56.2	46.2	15.5	-20.1	L	
11	0.91720	23.5	10.0	9.7	33.2	19.7	56.0	46.0	22.8	-26.3	L	
12	1.40996	19.1	7.6	9.8	28.9	17.4	56.0	46.0	27.1	-28.6	L	

Calculation:Result [dBuV] =Reading [dBuV] +C.Fac (LISN+Cable) [dB]
LISN:CLS-25

Conducted Emission
(With Cradle: HA-P62IO)

Test place	Kashima EMC Lab. No.2 Shielded Room
Report No.	11242579M
Date	May 26, 2016
Temperature / Humidity	22 deg. C / 59 % RH
Engineer	Kazuhiro Ando
Mode	Tx, Hopping Off, DH5

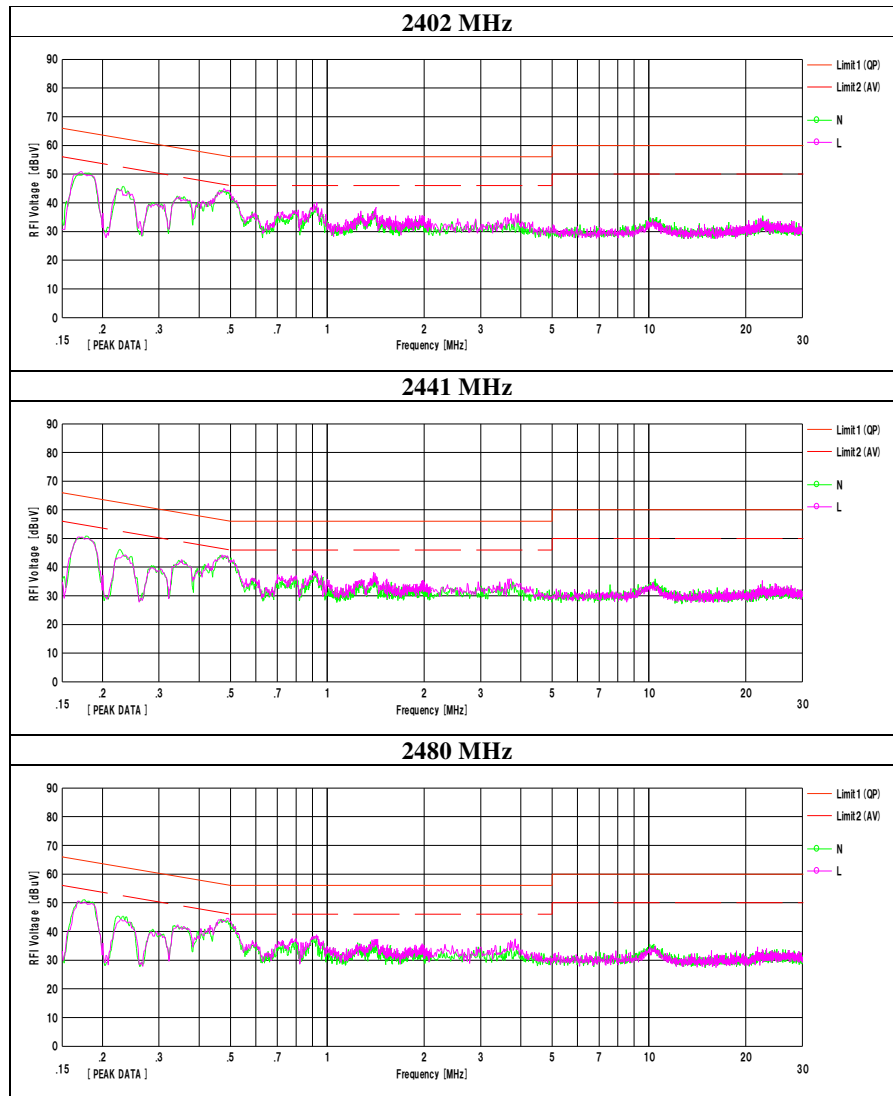

Conducted Emission
(With Cradle: HA-P62IO)

DATA OF CONDUCTED EMISSION TEST

UL Japan, Inc. Kashima EMC Lab. No.2 Shielded Room
Date : 2016/05/26

Mode : Tx, 3DH5, 2402MHz
Order No. : 11242579M
Power : AC 120V / 60Hz
Temp./Humi. : 22deg.C / 59%RH

Limit1 : FCC 15C (15.207) ClassB QP
Limit2 : FCC 15C (15.207) ClassB AV

Tested by : Kazuhiro Ando

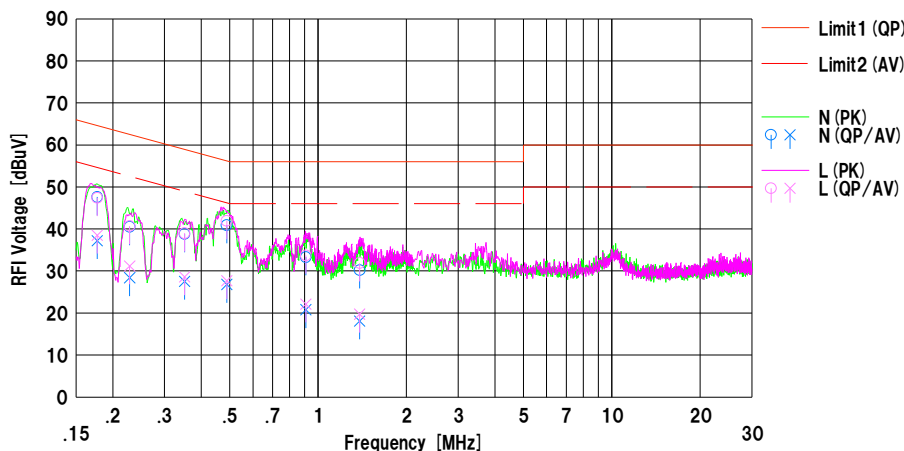

No.	Freq. [MHz]	Reading		C.Fac [dB]	Results		Limit		Margin		Phase	Comment
		<QP>	<AV>		<QP>	<AV>	<QP>	<AV>	<QP>	<AV>		
		[dBuV]	[dBuV]		[dBuV]	[dBuV]	[dBuV]	[dBuV]	[dB]	[dB]		
1	0.17700	37.9	27.5	9.7	47.6	37.2	64.6	54.6	17.0	17.4	N	
2	0.22830	30.8	18.7	9.7	40.5	28.4	62.5	52.5	22.0	24.1	N	
3	0.35112	29.1	17.9	9.7	38.8	27.5	58.9	48.9	20.1	21.4	N	
4	0.48873	31.2	17.1	9.7	40.9	26.8	56.2	46.2	15.3	19.4	N	
5	0.90875	23.6	11.1	9.7	33.3	20.8	56.0	46.0	22.7	25.2	N	
6	1.38640	20.4	8.3	9.8	30.2	18.1	56.0	46.0	25.8	27.9	N	
7	0.17700	37.7	28.8	9.7	47.4	38.5	64.6	54.6	17.2	16.1	L	
8	0.22830	31.0	21.5	9.7	40.7	31.2	62.5	52.5	21.8	21.3	L	
9	0.35112	29.3	18.9	9.7	39.0	28.6	58.9	48.9	19.9	20.3	L	
10	0.48873	32.2	18.0	9.7	41.9	27.7	56.2	46.2	14.3	18.5	L	
11	0.90875	24.0	12.4	9.7	33.7	22.1	56.0	46.0	22.3	23.9	L	
12	1.38640	22.1	9.9	9.8	31.9	19.7	56.0	46.0	24.1	26.3	L	

Calculation:Result [dBuV] =Reading [dBuV] +C.Fac (LISN+Cable) [dB]
LISN:CLS-25

Conducted Emission
(With Cradle: HA-P62IO)

Test place	Kashima EMC Lab. No.2 Shielded Room
Report No.	11242579M
Date	May 26, 2016
Temperature / Humidity	22 deg. C / 59 % RH
Engineer	Kazuhiro Ando
Mode	Tx, Hopping Off, 3DH5

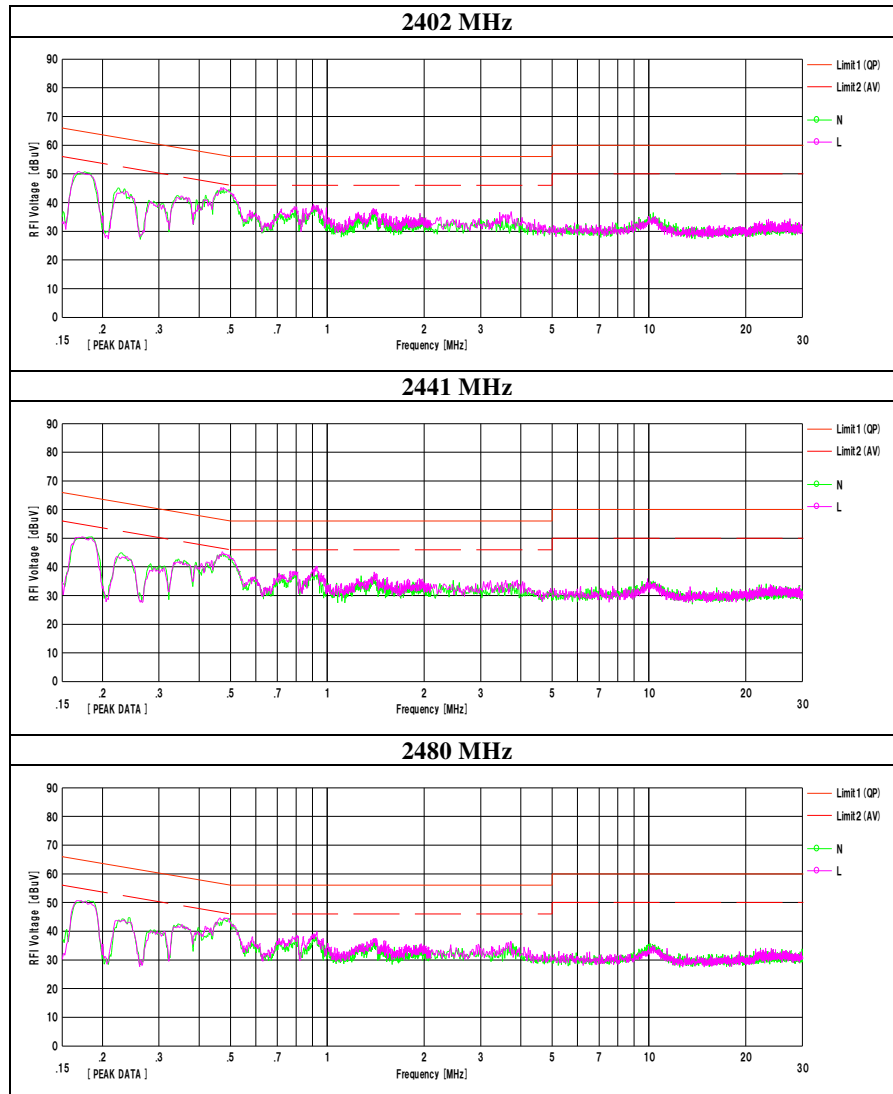

Conducted Emission
(With Cradle: HA-P60IO)

DATA OF CONDUCTED EMISSION TEST

UL Japan, Inc. Kashima EMC Lab. No.2 Shielded Room
Date : 2016/05/26

Mode : Tx, DH5, 2402MHz
Order No. : 11242579M
Power : AC 120V / 60Hz
Temp./Humi. : 22deg.C / 59%RH

Limit1 : FCC 15C (15.207) ClassB QP
Limit2 : FCC 15C (15.207) ClassB AV

Tested by : Kazuhiro Ando

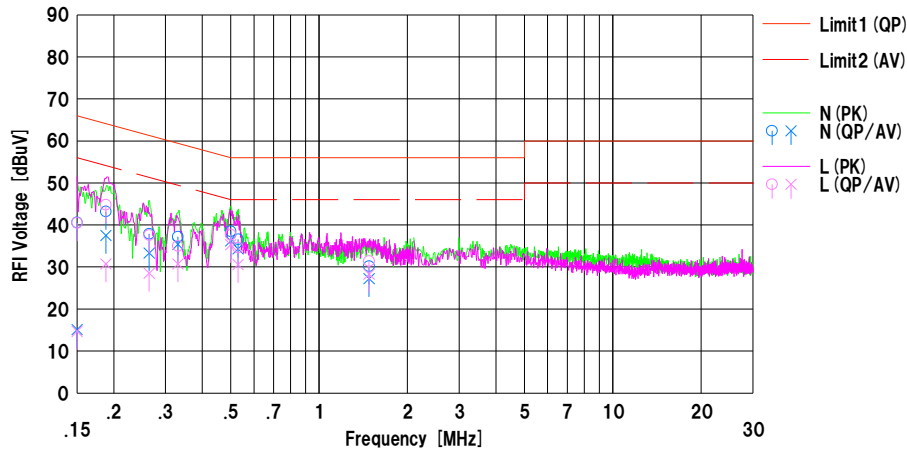

No.	Freq. [MHz]	Reading		C.Fac [dB]	Results		Limit		Margin		Phase	Comment
		<QP>	<AV>		<QP>	<AV>	<QP>	<AV>	<QP>	<AV>		
		[dBuV]	[dBuV]		[dBuV]	[dBuV]	[dBuV]	[dBuV]	[dB]	[dB]		
1	0.15000	30.9	5.4	9.7	40.6	15.1	66.0	56.0	25.4	40.9	N	
2	0.18800	33.5	27.8	9.7	43.2	37.5	64.1	54.1	20.9	16.6	N	
3	0.26420	28.2	23.6	9.7	37.9	33.3	61.3	51.3	23.4	18.0	N	
4	0.33067	27.5	25.7	9.7	37.2	35.4	59.4	49.4	22.2	14.0	N	
5	0.50000	28.8	26.5	9.7	38.5	36.2	56.0	46.0	17.5	9.8	N	
6	0.53025	26.9	24.6	9.7	36.6	34.3	56.0	46.0	19.4	11.7	N	
7	1.48080	20.4	17.4	9.8	30.2	27.2	56.0	46.0	25.8	18.8	N	
8	0.15000	30.8	5.0	9.7	40.5	14.7	66.0	56.0	25.5	41.3	L	
9	0.18800	35.1	21.0	9.7	44.8	30.7	64.1	54.1	19.3	23.4	L	
10	0.26420	27.9	18.8	9.7	37.6	28.5	61.3	51.3	23.7	22.8	L	
11	0.33067	25.3	21.0	9.7	35.0	30.7	59.4	49.4	24.4	18.7	L	
12	0.50000	28.0	25.6	9.7	37.7	35.3	56.0	46.0	18.3	10.7	L	
13	0.53025	24.9	20.9	9.7	34.6	30.6	56.0	46.0	21.4	15.4	L	
14	1.48080	21.6	18.5	9.8	31.4	28.3	56.0	46.0	24.6	17.7	L	

Calculation:Result [dBuV] =Reading [dBuV] +C.Fac (LISN+Cable) [dB]
LISN:CLS-25

Conducted Emission
(With Cradle: HA-P60IO)

Test place	Kashima EMC Lab. No.2 Shielded Room
Report No.	11242579M
Date	May 26, 2016
Temperature / Humidity	22 deg. C / 59 % RH
Engineer	Kazuhiro Ando
Mode	Tx, Hopping Off, DH5

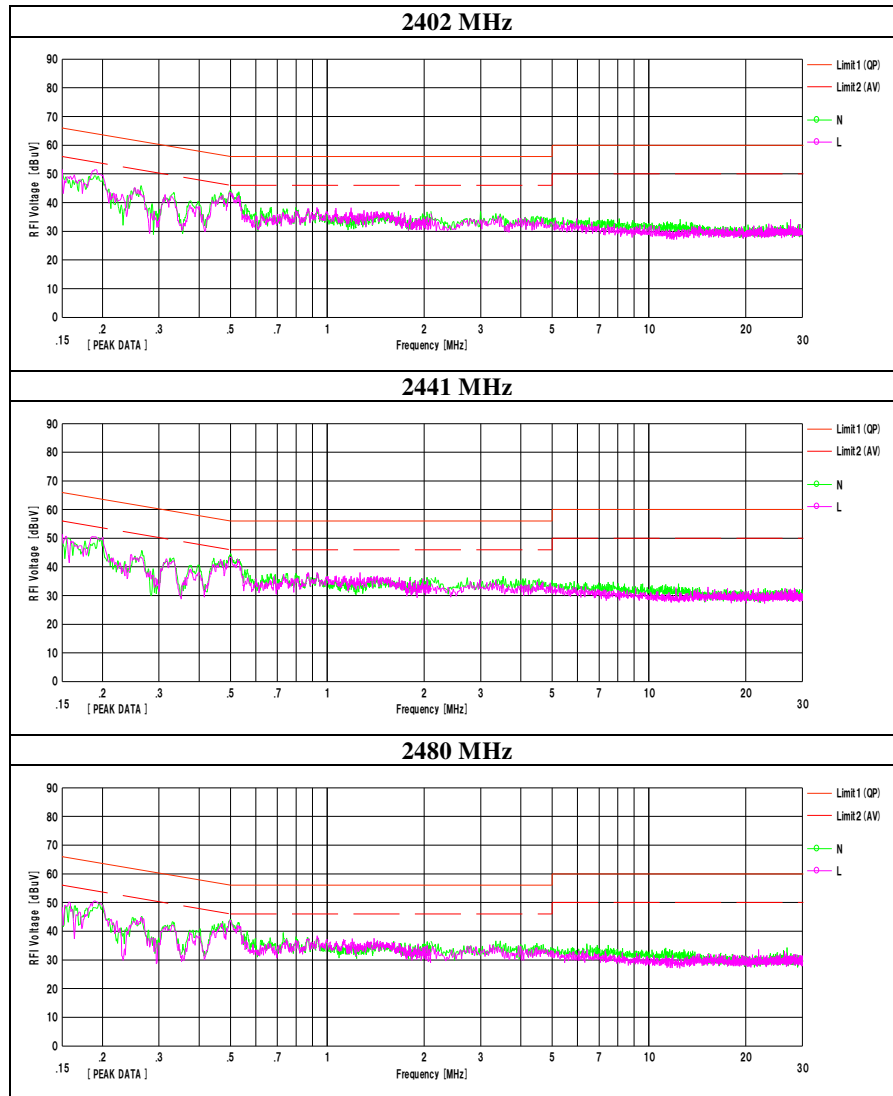

Conducted Emission
(With Cradle: HA-P60IO)

DATA OF CONDUCTED EMISSION TEST

UL Japan, Inc. Kashima EMC Lab. No.2 Shielded Room
Date : 2016/05/26

Company : CASIO COMPUTER CO., LTD.
Kind of EUT : Handheld Terminal
Model No. : IT-G500-C21E-US
Serial No. : 024SE LG6100629IAAC1
Remarks : With Cradle : HA-P60IO

Mode : Tx, 3DH5, 2402MHz
Order No. : 11242579M
Power : AC 120V / 60Hz
Temp./Humi. : 22deg.C / 59%RH

Limit1 : FCC 15C (15.207) ClassB QP
Limit2 : FCC 15C (15.207) ClassB AV

Tested by : Kazuhiro Ando

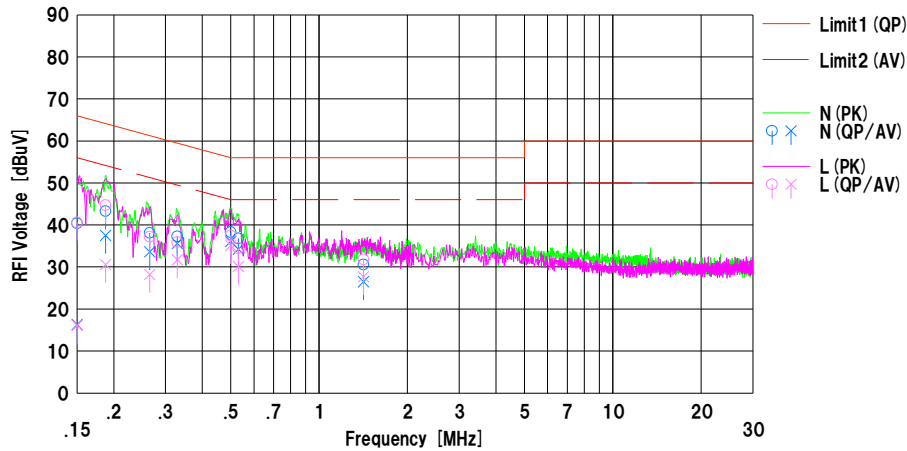

No.	Freq. [MHz]	Reading		C.Fac [dB]	Results		Limit		Margin		Phase	Comment
		<QP>	<AV>		<QP>	<AV>	<QP>	<AV>	<QP>	<AV>		
		[dBuV]	[dBuV]		[dBuV]	[dBuV]	[dBuV]	[dBuV]	[dB]	[dB]		
1	0.15000	30.7	6.6	9.7	40.4	16.3	66.0	56.0	25.6	39.7	N	
2	0.18740	33.6	27.8	9.7	43.3	37.5	64.2	54.2	20.9	16.7	N	
3	0.26485	28.4	23.9	9.7	38.1	33.6	61.3	51.3	23.2	17.7	N	
4	0.32928	27.6	25.0	9.7	37.3	35.6	59.5	49.5	22.2	13.9	N	
5	0.50000	28.6	26.4	9.7	38.3	36.1	56.0	46.0	17.7	9.9	N	
6	0.53100	27.1	24.5	9.7	36.8	34.2	56.0	46.0	19.2	11.8	N	
7	1.41635	20.8	16.7	9.8	30.6	26.5	56.0	46.0	25.4	19.5	N	
8	0.15000	30.9	6.4	9.7	40.6	16.1	66.0	56.0	25.4	39.9	L	
9	0.18740	35.0	20.9	9.7	44.7	30.6	64.2	54.2	19.5	23.6	L	
10	0.26485	27.5	18.5	9.7	37.2	28.2	61.3	51.3	24.1	23.1	L	
11	0.32928	26.2	22.0	9.7	35.9	31.7	59.5	49.5	23.6	17.8	L	
12	0.50000	27.8	25.4	9.7	37.5	35.1	56.0	46.0	18.5	10.9	L	
13	0.53100	24.8	20.4	9.7	34.5	30.1	56.0	46.0	21.5	15.9	L	
14	1.41635	22.0	17.9	9.8	31.8	27.7	56.0	46.0	24.2	18.3	L	

Calculation:Result [dBuV] =Reading [dBuV] +C.Fac (LISN+Cable) [dB]
LISN:CLS-25

Conducted Emission
(With Cradle: HA-P60IO)

Test place	Kashima EMC Lab. No.2 Shielded Room
Report No.	11242579M
Date	May 26, 2016
Temperature / Humidity	22 deg. C / 59 % RH
Engineer	Kazuhiro Ando
Mode	Tx, Hopping Off, 3DH5

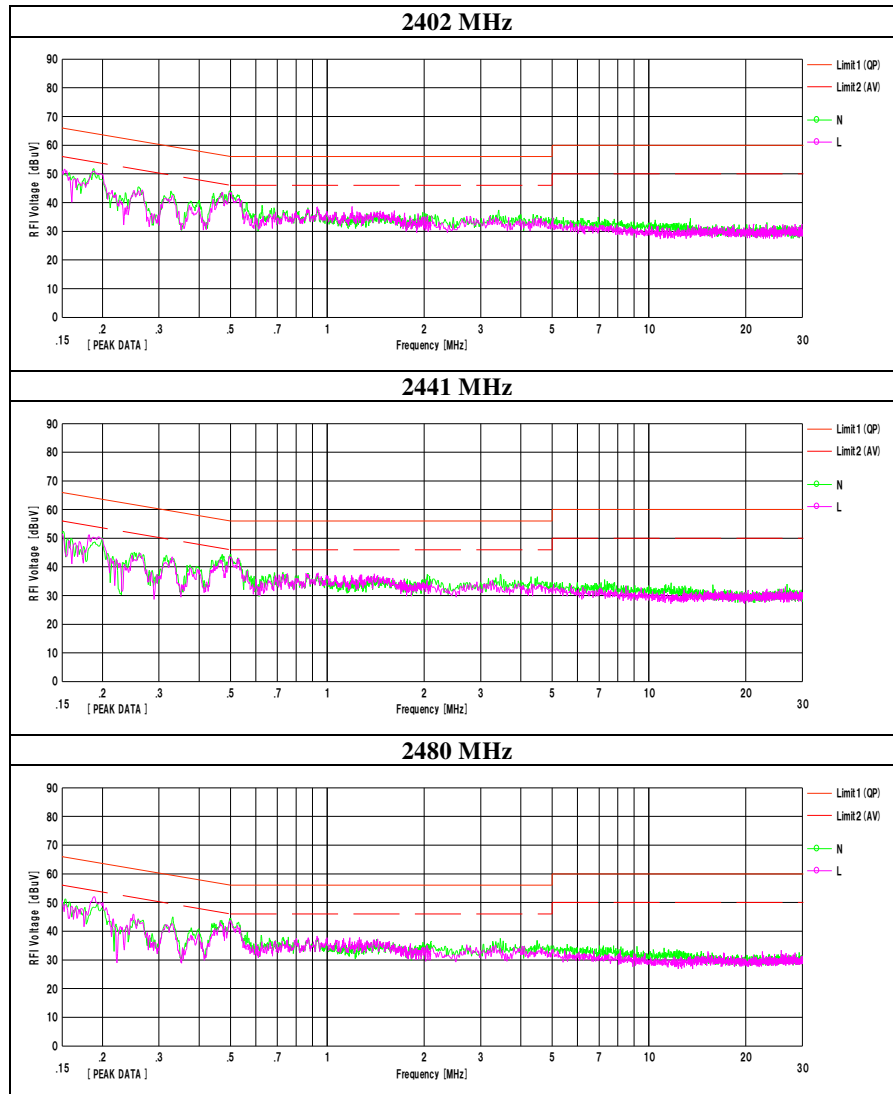

20dB Bandwidth and Carrier Frequency Separation

Test place Kashima EMC Lab. No.2 Measurement Room
Report No. 11242579M
Date April 27, 2016
Temperature / Humidity 22 deg. C / 55 % RH
Engineer Kazuhiro Ando
Mode Tx, Hopping Off, DH5, 3DH5

Mode	Freq. [MHz]	20dB Bandwidth [MHz]	Carrier Frequency Separation [MHz]	Limit for Carrier Frequency separation [MHz]
DH5	2402.0	0.936	1.000	>= 0.624
DH5	2441.0	0.935	1.000	>= 0.623
DH5	2480.0	0.937	1.000	>= 0.624
3DH5	2402.0	1.323	1.000	>= 0.882
3DH5	2441.0	1.306	1.000	>= 0.871
3DH5	2480.0	1.324	1.000	>= 0.883

Limit: Two-thirds of 20dB Bandwidth or 25kHz (whichever is greater).

No limit applies to 20dB Bandwidth.

20dB Bandwidth and Carrier Frequency Separation

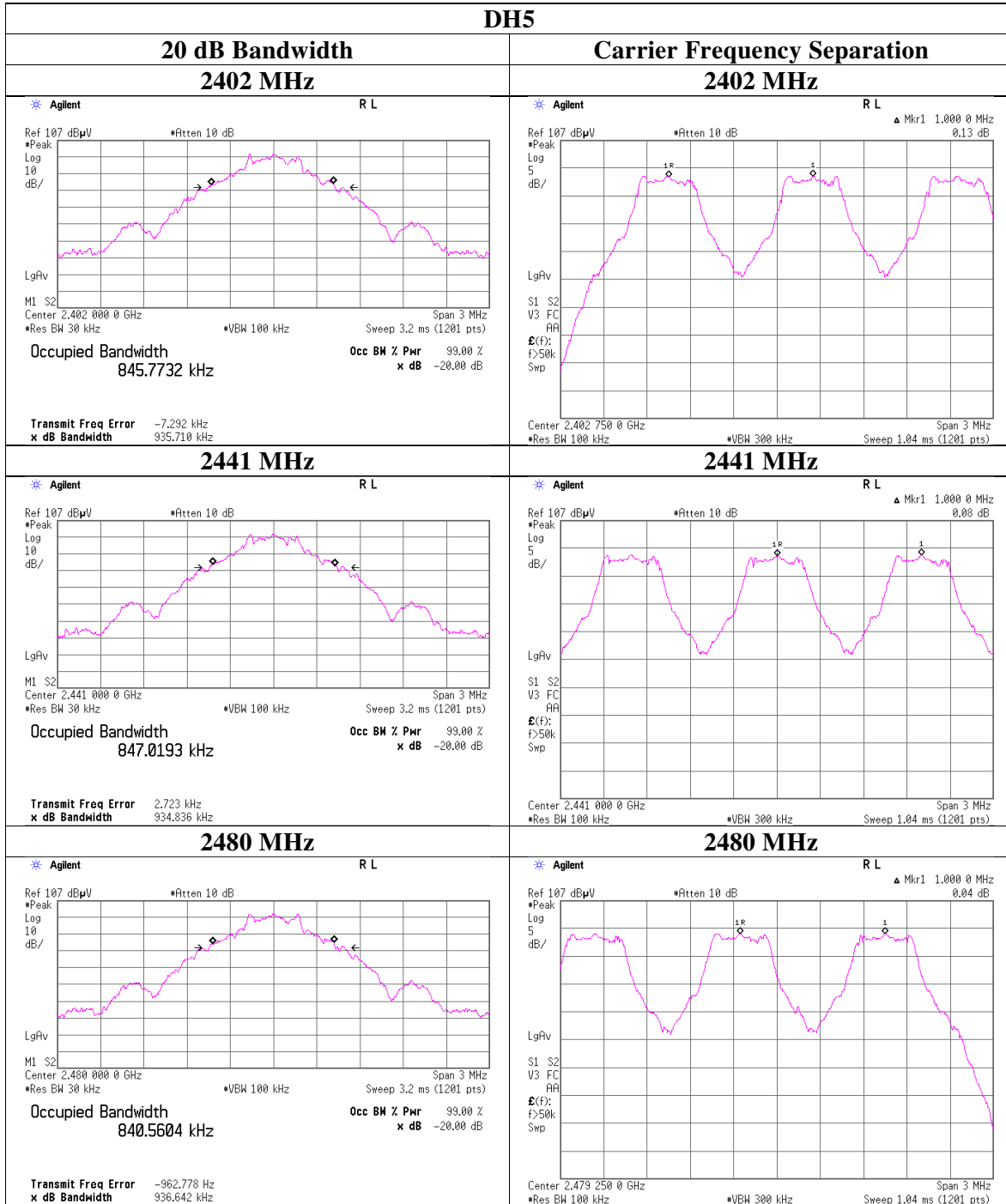

20dB Bandwidth and Carrier Frequency Separation

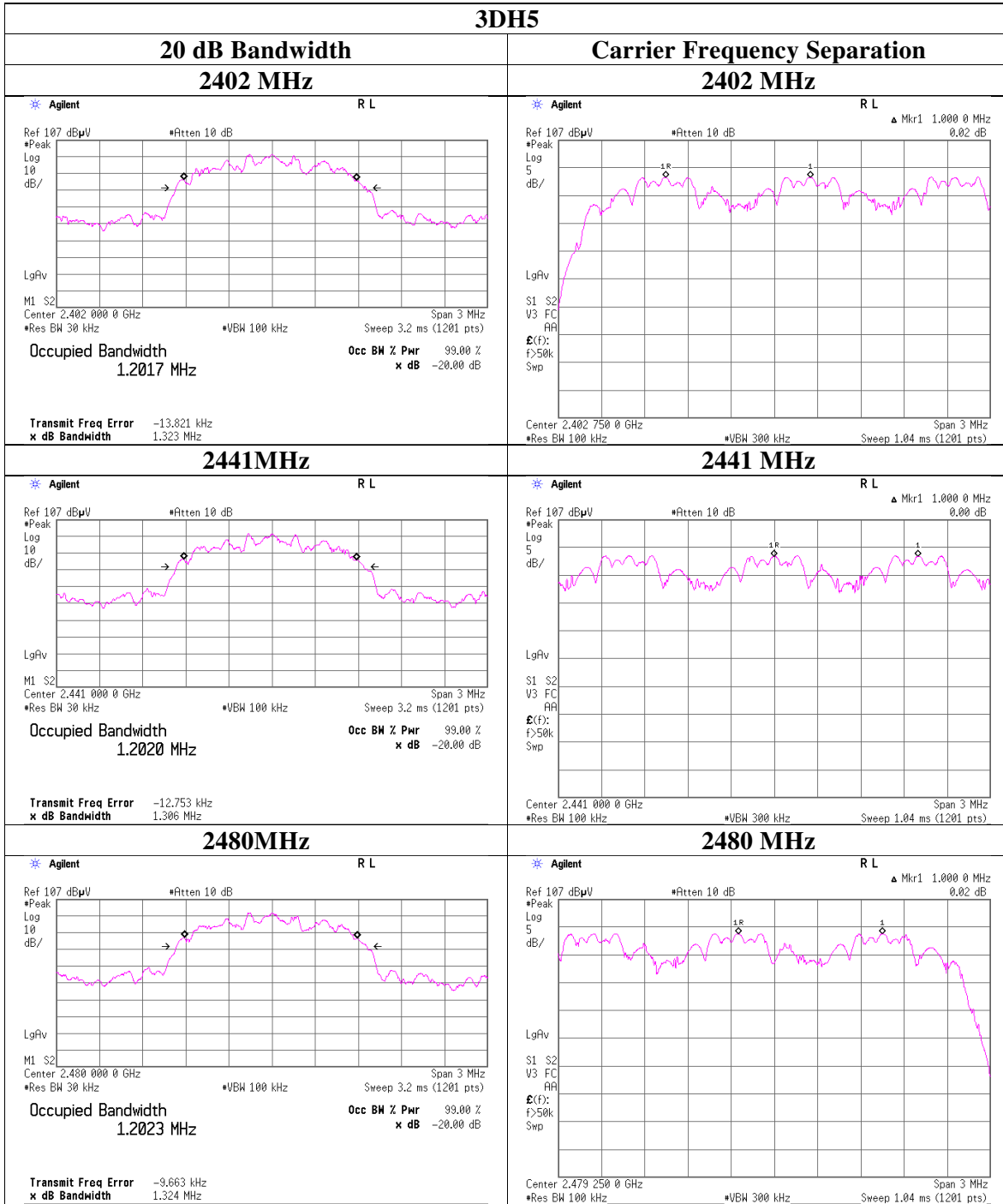

Number of Hopping Frequency

Test place Kashima EMC Lab. No.2 Measurement Room
Report No. 11242579M
Date April 27, 2016
Temperature / Humidity 22 deg. C / 55 % RH
Engineer Kazuhiro Ando
Mode Tx, Hopping On

Mode	Number of channel [channels]	Limit [channels]
DH5	79	>= 15
3DH5	79	>= 15

Test was not performed at AFH mode whose number of hopping channel is 20 channels because this Bluetooth radio is in compliance of Bluetooth Specification.

Number of Hopping Frequency

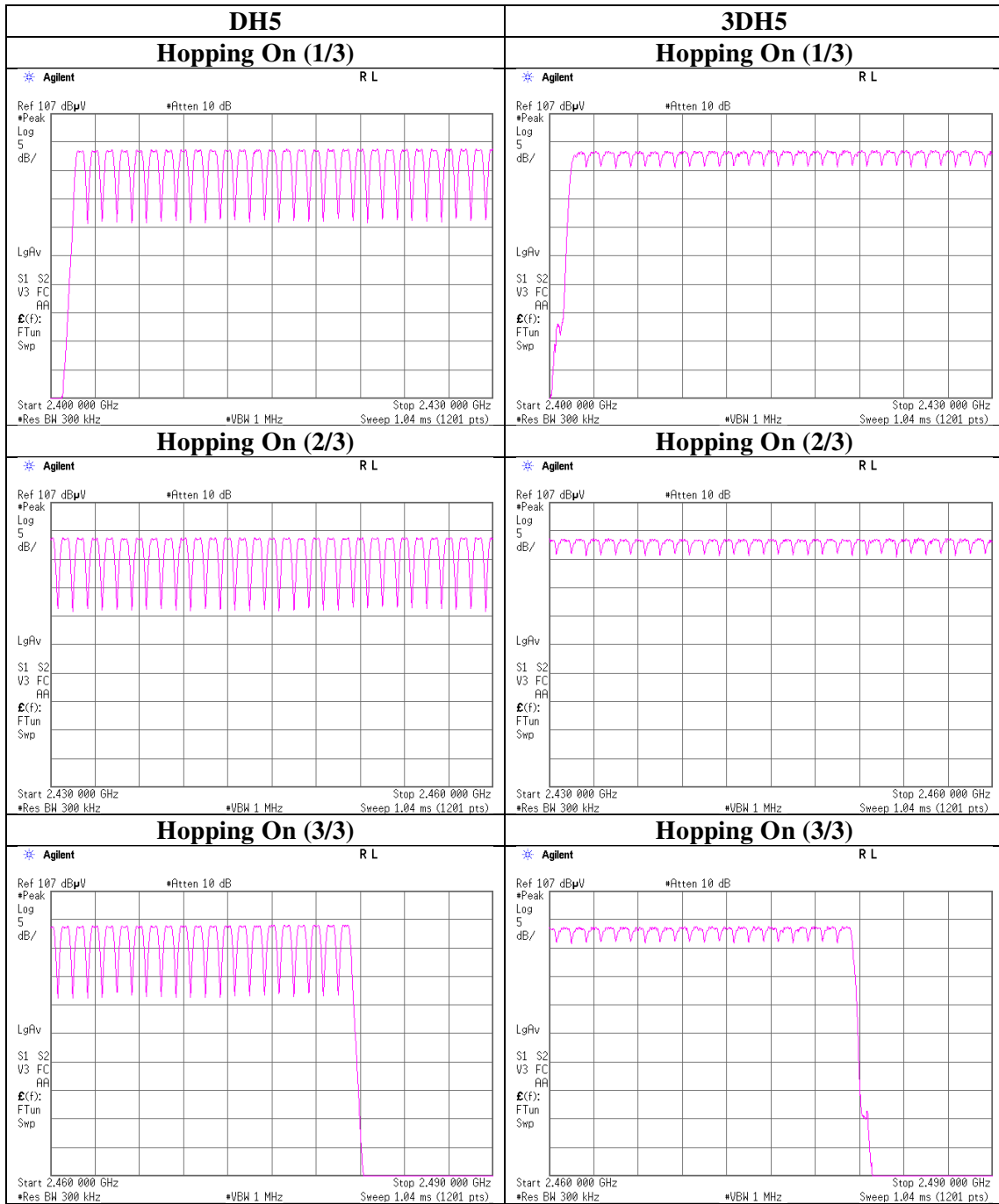

Dwell time

Test place	Kashima EMC Lab. No.2 Measurement Room
Report No.	11242579M
Date	April 27, 2016
Temperature / Humidity	22 deg. C / 55 % RH
Engineer	Kazuhiro Ando
Mode	Tx, Hopping On

Mode	Number of transmission in a 31.6(79 Hopping x 0.4) / 12.8 (32 Hopping x 0.4) second period	Length of transmission [msec]	Result [msec]	Limit [msec]
DH1	48.4 times / 5 sec. x 31.6 sec. = 306 times	0.423	129	400
DH3	25.6 times / 5 sec. x 31.6 sec. = 162 times	1.679	272	400
DH5	18.4 times / 5 sec. x 31.6 sec. = 117 times	2.933	343	400
3DH1	48.4 times / 5 sec. x 31.6 sec. = 306 times	0.427	131	400
3DH3	26.2 times / 5 sec. x 31.6 sec. = 166 times	1.680	279	400
3DH5	18.6 times / 5 sec. x 31.6 sec. = 118 times	2.934	346	400

Sample Calculation

Result = Number of transmission x Length of transmission

*Average data of 5 tests.(except Inquiry)

Mode	Sampling [times]					Average [times]
	1	2	3	4	5	
DH1	47	48	48	49	50	48.4
DH3	25	24	27	25	27	25.6
DH5	18	20	19	17	18	18.4
3DH1	49	46	49	48	50	48.4
3DH3	27	26	26	25	27	26.2
3DH5	19	19	17	20	18	18.6

Sample Calculation

Average = Summation (Sampling 1 to 5) / 5

This device complies with the Bluetooth protocol for FHSS operation, employing a pseudo random channel selection and hopping rate to ensure that the occupancy time in $N \times 0.4s$, where N is the number of channels being used in the hopping sequence ($20 \leq N \leq 79$), is always less than $0.4s$ regardless of packet size. This is confirmed in the test report for $N = 79$.

UL Japan, Inc.

Kashima EMC Lab.

1614, Mushihata, Katori-shi, Chiba-ken, 289-0341 Japan

Telephone : +81-478-88-6500

Facsimile : +81-478-82-3373

Dwell time

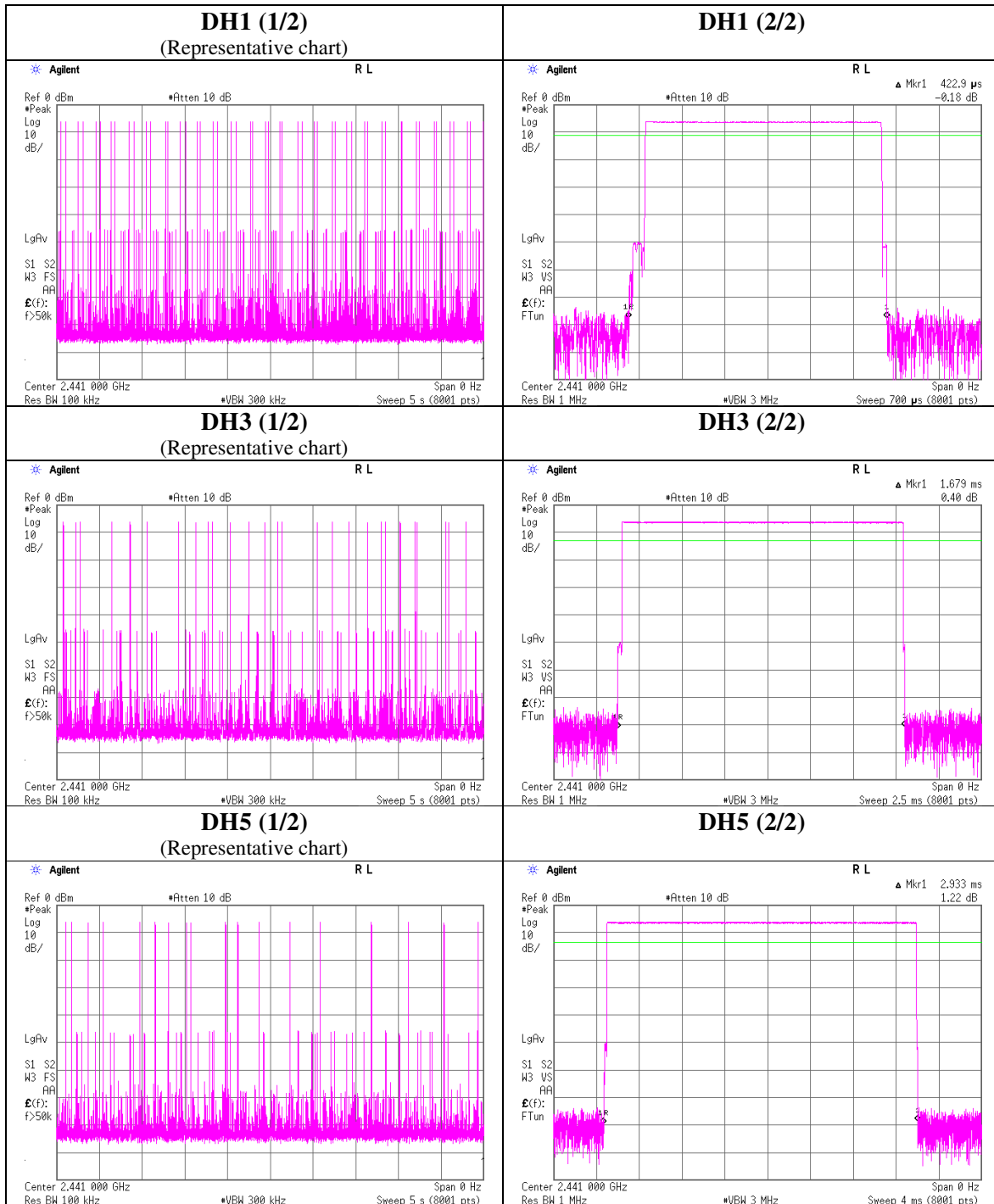

Dwell time

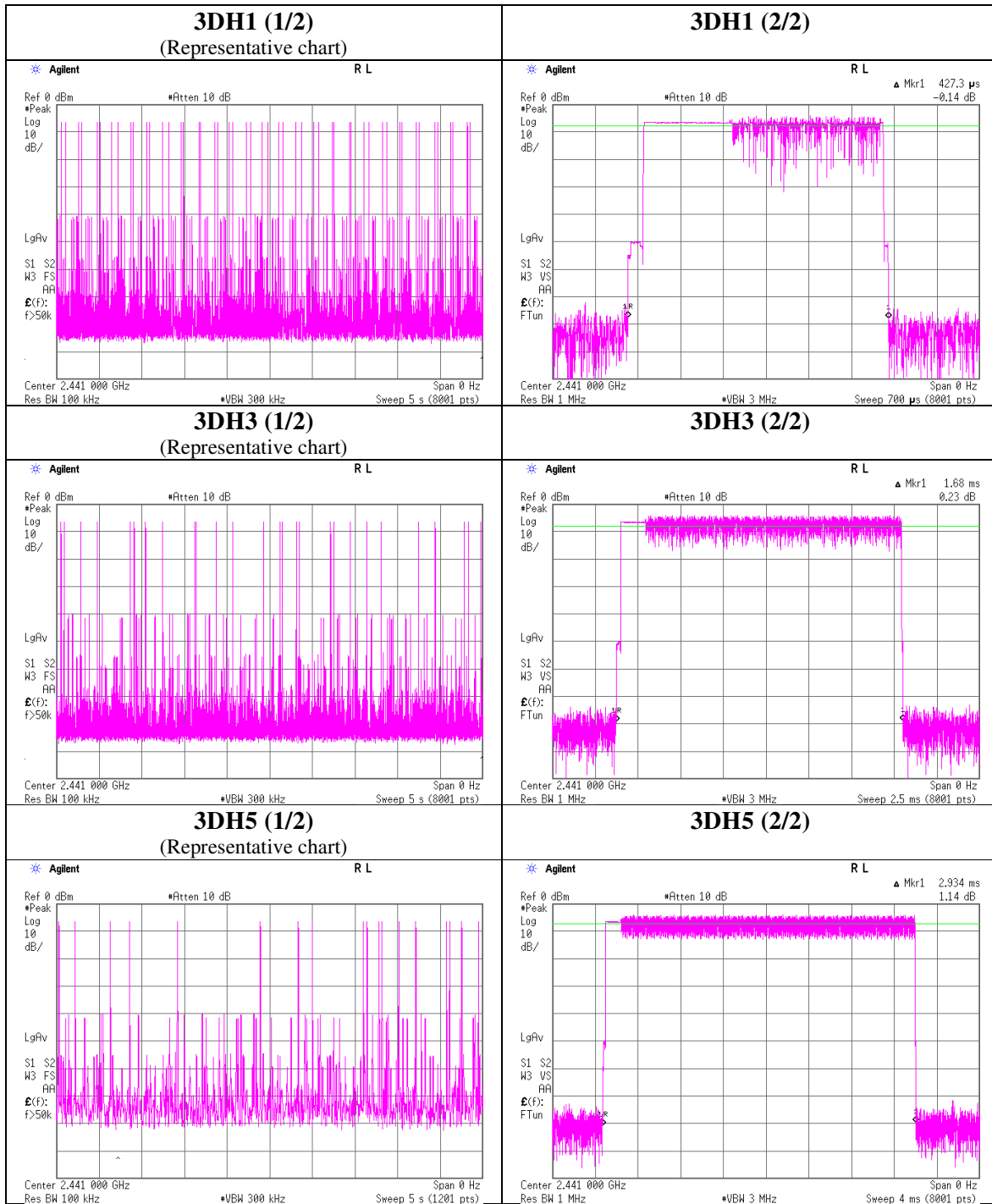

Maximum Peak Output Power

Test place : Kashima EMC Lab. No.2 Measurement Room
 Report No. : 11242579M
 Date : May 25, 2016
 Temperature / Humidity : 23 deg. C / 45 % RH
 Engineer : Kazuhiro Ando
 Mode : Tx, Hopping Off

Mode	Freq. [MHz]	Reading [dBm]	Cable Loss [dB]	Atten. Loss [dB]	Result		Limit		Margin [dB]
					[dBm]	[mW]	[dBm]	[mW]	
DH5	2402.0	-8.85	1.28	10.03	2.46	1.76	20.96	125	18.50
DH5	2441.0	-8.75	1.28	10.03	2.56	1.80	20.96	125	18.40
DH5	2480.0	-8.58	1.29	10.03	2.74	1.88	20.96	125	18.22
2DH5	2402.0	-5.97	1.28	10.03	5.34	3.42	20.96	125	15.62
2DH5	2441.0	-5.69	1.28	10.03	5.62	3.65	20.96	125	15.34
2DH5	2480.0	-5.50	1.29	10.03	5.82	3.82	20.96	125	15.14
3DH5	2402.0	-5.56	1.28	10.03	5.75	3.76	20.96	125	15.21
3DH5	2441.0	-5.36	1.28	10.03	5.95	3.94	20.96	125	15.01
3DH5	2480.0	-5.11	1.29	10.03	6.21	4.18	20.96	125	14.75

Sample Calculation:

Result = Reading + Cable Loss (including the cable(s) customer supplied) + Attenuator Loss

*The equipment and cables were not used for factor 0 dB of the data sheets.

Test was not performed at AFH mode, because the decrease of number of channel (min: 20ch) at AFH mode does not influence on the output power and bandwidth of the EUT.

As this device had AFH mode and frequency separation could not meet the requirement of over 20dB BW without 2/3 relaxation, 125mW power limit was applied to it.

However, the limit level 125mW of AFH mode was used for the test.

UL Japan, Inc.

Kashima EMC Lab.

1614, Mushihata, Katori-shi, Chiba-ken, 289-0341 Japan

Telephone : +81-478-88-6500

Facsimile : +81-478-82-3373

Average Output Power
(Reference data)

Test place Kashima EMC Lab. No.2 Measurement Room
Report No. 11242579M
Date May 25, 2016
Temperature / Humidity 23 deg. C / 45 % RH
Engineer Kazuhiro Ando
Mode Tx, Hopping Off

Mode	Freq. [MHz]	Reading [dBm]	Cable Loss [dB]	Atten. Loss [dB]	Result (Frame power)	
					[dBm]	[mW]
DH5	2402.0	-10.31	1.28	10.03	1.00	1.26
DH5	2441.0	-10.18	1.28	10.03	1.13	1.30
DH5	2480.0	-10.00	1.29	10.03	1.32	1.36
2DH5	2402.0	-10.04	1.28	10.03	1.27	1.34
2DH5	2441.0	-9.89	1.28	10.03	1.42	1.39
2DH5	2480.0	-9.69	1.29	10.03	1.63	1.46
3DH5	2402.0	-10.04	1.28	10.03	1.27	1.34
3DH5	2441.0	-9.88	1.28	10.03	1.43	1.39
3DH5	2480.0	-9.69	1.29	10.03	1.63	1.46

Sample Calculation:

Result (Frame power) = Reading + Cable Loss (including the cable(s) customer supplied) + Attenuator

*The equipment and cables were not used for factor 0 dB of the data sheets.

Burst Rate Confirmation

Test place	Kashima EMC Lab. No.2 Measurement Room
Report No.	11242579M
Date	May 25, 2016
Temperature / Humidity	23 deg. C / 45 % RH
Engineer	Kazuhiro Ando
Mode	Tx, Hopping Off

DH5

3DH5

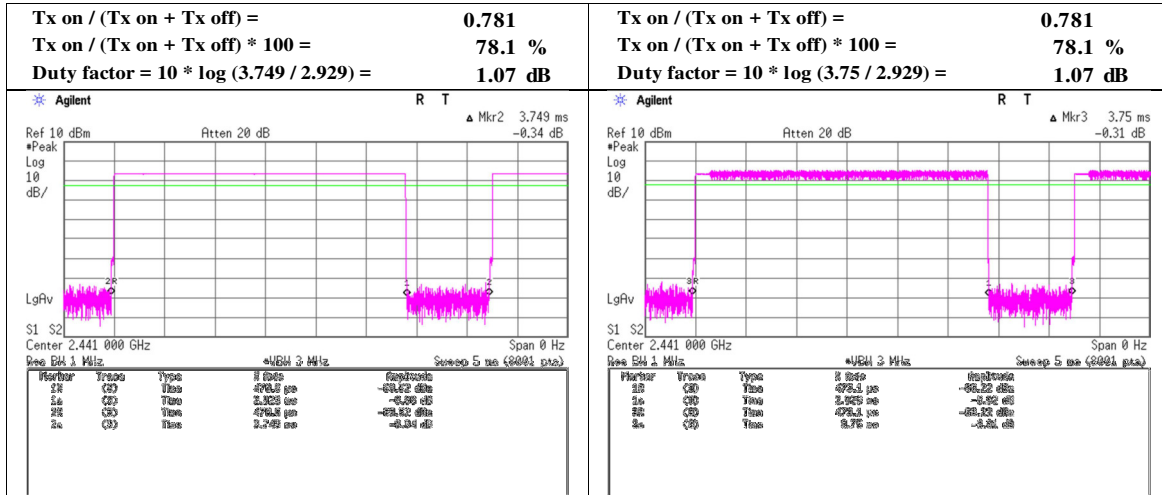

UL Japan, Inc.

Kashima EMC Lab.

1614, Mushihata, Katori-shi, Chiba-ken, 289-0341 Japan

Telephone : +81-478-88-6500

Facsimile : +81-478-82-3373

Radiated Spurious Emission

Test place Kashima EMC Lab. No.10 Semi Anechoic Chamber
Report No. 11242579M
Date April 28, 2016 May 9, 2016 May 9, 2016 May 10, 2016 May 25, 2016
Temperature / Humidity 22 deg. C 21 deg. C 21 deg. C 21 deg. C 23 deg. C
 40 % RH 52 % RH 52 % RH 55 % RH 52 % RH
Engineer Kazuhiro Ando Kazuhiro Ando Kazuhiro Ando Kazuhiro Ando Kazuhiro Ando
 (30-1000MHz) (1-10GHz) (10-18GHz) (18-26.5GHz) (1-26.5GHz)
Mode Tx, Hopping Off, DH5 2402 MHz

Polarity	Frequency [MHz]	Detector	Reading [dBuV]	Ant.Fac. [dB/m]	Loss [dB]	Gain [dB]	Distance Factor [dB]	Result [dBuV/m]	Limit [dBuV/m]	Margin [dB]	Height [cm]	Angle [deg]	Remark
Hori.	134.415	QP	27.5	12.8	5.6	26.5	0.0	19.4	43.5	24.1	155	150	
Hori.	536.370	QP	34.3	18.3	9.0	27.5	0.0	34.1	46.0	11.9	138	310	
Hori.	2366.580	PK	56.0	27.7	14.0	44.4	3.5	56.8	73.9	17.1	150	199	
Hori.	2390.000	PK	49.2	27.6	14.0	44.4	3.5	49.9	73.9	24.0	164	208	
Hori.	4804.000	PK	56.8	31.3	6.1	46.1	3.5	51.6	73.9	22.3	148	154	
Hori.	7206.000	PK	48.8	36.3	7.5	44.7	3.5	51.4	73.9	22.5	150	0	Floor noise
Hori.	2366.580	AV	37.4	27.7	14.0	44.4	3.5	38.2	53.9	15.7	150	199	
Hori.	2390.000	AV	37.4	27.6	14.0	44.4	3.5	38.1	53.9	15.8	164	208	
Hori.	4804.000	AV	49.2	31.3	6.1	46.1	3.5	44.0	53.9	9.9	148	154	
Hori.	7206.000	AV	36.8	36.3	7.5	44.7	3.5	39.4	53.9	14.5	150	0	Floor noise
Vert.	134.412	QP	34.7	12.8	5.6	26.5	0.0	26.6	43.5	16.9	100	250	
Vert.	195.050	QP	33.2	10.2	6.3	26.3	0.0	23.4	43.5	20.1	100	0	
Vert.	219.432	QP	32.0	9.8	6.5	26.1	0.0	22.2	46.0	23.8	100	0	
Vert.	536.376	QP	33.3	18.3	9.0	27.5	0.0	33.1	46.0	12.9	100	355	
Vert.	2365.760	PK	53.9	27.7	14.0	44.4	3.5	54.7	73.9	19.2	150	148	
Vert.	2390.000	PK	48.6	27.6	14.0	44.4	3.5	49.3	73.9	24.6	197	126	
Vert.	3202.680	PK	55.3	28.9	5.6	44.5	3.5	48.8	73.9	25.1	174	236	
Vert.	4804.000	PK	56.3	31.3	6.1	46.1	3.5	51.1	73.9	22.8	161	106	
Vert.	7206.000	PK	48.3	36.3	7.5	44.7	3.5	50.9	73.9	23.0	150	0	Floor noise
Vert.	2365.760	AV	36.8	27.7	14.0	44.4	3.5	37.6	53.9	16.3	150	148	
Vert.	2390.000	AV	36.7	27.6	14.0	44.4	3.5	37.4	53.9	16.5	197	126	
Vert.	3202.680	AV	49.1	28.9	5.6	44.5	3.5	42.6	53.9	11.3	174	236	
Vert.	4804.000	AV	49.6	31.3	6.1	46.1	3.5	44.4	53.9	9.5	161	106	
Vert.	7206.000	AV	36.5	36.3	7.5	44.7	3.5	39.1	53.9	14.8	150	0	Floor noise

Result = Reading + Ant.Fac. + Loss (Cable+(Attenuator or Filter)(below 18 GHz)) - Gain(Amplifier) + Distance factor

Distance factor : 1 GHz - 10 GHz : $20\log(4.5\text{ m} / 3.0\text{ m}) = 3.5\text{ dB}$

10 GHz - 26.5 GHz : $20\log(1.0\text{ m} / 3.0\text{ m}) = -9.5\text{ dB}$

20 dBc Data Sheet (RBW 100 kHz, VBW 300 kHz)

Polarity	Frequency [MHz]	Detector	Reading [dBuV]	Ant.Fac. [dB/m]	Loss [dB]	Gain [dB]	Distance Factor [dB]	Result [dBuV/m]	Limit [dBuV/m]	Margin [dB]	Remark
Hori.	2402.000	PK	97.8	27.6	14.0	44.4	3.5	98.5	-	-	Carrier
Hori.	2400.000	PK	42.5	27.6	14.0	44.4	3.5	43.2	78.5	35.3	
Vert.	2402.000	PK	96.1	27.6	14.0	44.4	3.5	96.8	-	-	Carrier
Vert.	2400.000	PK	40.3	27.6	14.0	44.4	3.5	41.0	76.8	35.8	

Result = Reading + Ant.Fac. + Loss (Cable+(Attenuator or Filter)(below 18 GHz)) - Gain(Amplifier) + Distance factor

Distance factor : 1 GHz - 10 GHz : $20\log(4.5\text{ m} / 3.0\text{ m}) = 3.5\text{ dB}$

10 GHz - 26.5 GHz : $20\log(1.0\text{ m} / 3.0\text{ m}) = -9.5\text{ dB}$

***These results have sufficient margin without taking account Dwell time factor.**

UL Japan, Inc.

Kashima EMC Lab.

1614, Mushihata, Katori-shi, Chiba-ken, 289-0341 Japan

Telephone : +81-478-88-6500

Facsimile : +81-478-82-3373

Radiated Spurious Emission
(Reference Plot for band-edge)

Test place	Kashima EMC Lab. No.10 Semi Anechoic Chamber
Report No.	11242579M
Date	May 9, 2016
Temperature / Humidity	21 deg. C / 52 % RH
Engineer	Kazuhiro Ando (1-10GHz)
Mode	Tx, Hopping Off, DH5 2402 MHz

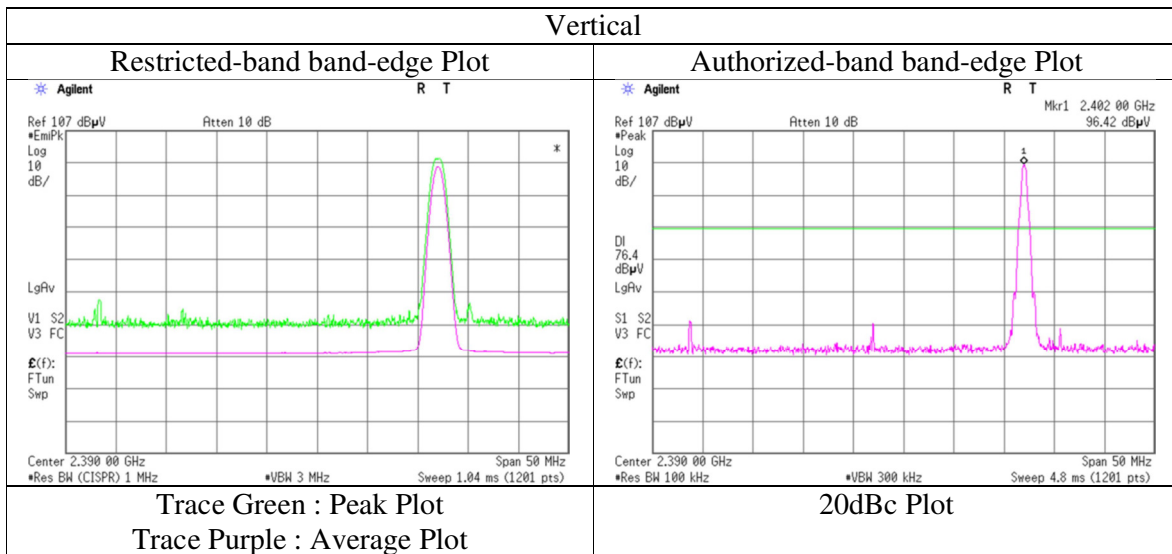
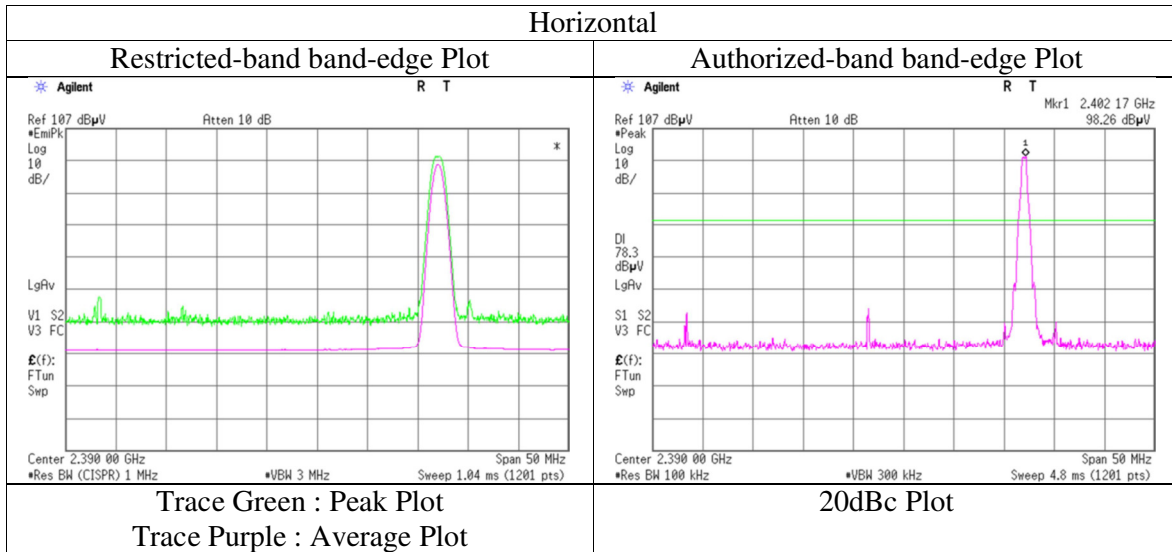

* Final result of restricted band edge was shown in tabular data.

Radiated Spurious Emission

Test place Kashima EMC Lab. No.10 Semi Anechoic Chamber
Report No. 11242579M
Date April 28, 2016 May 9, 2016 May 9, 2016 May 10, 2016 May 25, 2016
Temperature / Humidity 22 deg. C 21 deg. C 21 deg. C 21 deg. C 23 deg. C
 40 % RH 52 % RH 52 % RH 55 % RH 52 % RH
Engineer Kazuhiro Ando Kazuhiro Ando Kazuhiro Ando Kazuhiro Ando Kazuhiro Ando
 (30-1000MHz) (1-10GHz) (10-18GHz) (18-26.5GHz) (1-26.5GHz)
Mode Tx, Hopping Off, DH5 2441 MHz

Polarity	Frequency [MHz]	Detector	Reading [dBuV]	Ant.Fac. [dB/m]	Loss [dB]	Gain [dB]	Distance Factor [dB]	Result [dBuV/m]	Limit [dBuV/m]	Margin [dB]	Height [cm]	Angle [deg]	Remark
Hori.	170.666	QP	28.9	13.0	6.0	26.4	0.0	21.5	43.5	22.0	150	140	
Hori.	536.385	QP	35.3	18.3	9.0	27.5	0.0	35.1	46.0	10.9	129	300	
Hori.	2387.020	PK	54.2	27.6	14.0	44.4	3.5	54.9	73.9	19.0	150	217	
Hori.	4882.000	PK	59.5	31.2	6.2	46.1	3.5	54.3	73.9	19.6	185	162	
Hori.	7323.000	PK	48.2	36.5	7.8	44.4	3.5	51.6	73.9	22.3	150	0	Floor noise
Hori.	2387.020	AV	37.0	27.6	14.0	44.4	3.5	37.7	53.9	16.2	150	217	
Hori.	4882.000	AV	53.7	31.2	6.2	46.1	3.5	48.5	53.9	5.4	185	162	
Hori.	7323.000	AV	35.9	36.5	7.8	44.4	3.5	39.3	53.9	14.6	150	0	Floor noise
Vert.	182.845	QP	38.8	11.6	6.2	26.3	0.0	30.3	43.5	13.2	100	0	
Vert.	195.050	QP	36.5	10.2	6.3	26.3	0.0	26.7	43.5	16.8	100	0	
Vert.	207.221	QP	38.7	9.8	6.4	26.2	0.0	28.7	43.5	14.8	100	350	
Vert.	536.385	QP	35.1	18.3	9.0	27.5	0.0	34.9	46.0	11.1	100	295	
Vert.	2386.910	PK	54.4	27.6	14.0	44.4	3.5	55.1	73.9	18.8	139	126	
Vert.	4882.000	PK	60.4	31.2	6.2	46.1	3.5	55.2	73.9	18.7	144	97	
Vert.	7323.000	PK	48.1	36.5	7.8	44.4	3.5	51.5	73.9	22.4	150	0	Floor noise
Vert.	2386.910	AV	37.1	27.6	14.0	44.4	3.5	37.8	53.9	16.1	139	126	
Vert.	4882.000	AV	55.2	31.2	6.2	46.1	3.5	50.0	53.9	3.9	144	97	
Vert.	7323.000	AV	35.9	36.5	7.8	44.4	3.5	39.3	53.9	14.6	150	0	Floor noise

Result = Reading + Ant.Fac. + Loss (Cable+(Attenuator or Filter)(below 18 GHz)) - Gain(Amplifier) + Distance factor

Distance factor : 1 GHz - 10 GHz : 20log (4.5 m / 3.0 m) = 3.5 dB

10 GHz - 26.5 GHz : 20log (1.0 m / 3.0 m) = -9.5 dB

* These results have sufficient margin without taking account Dwell time factor.

UL Japan, Inc.

Kashima EMC Lab.

1614, Mushihata, Katori-shi, Chiba-ken, 289-0341 Japan

Telephone : +81-478-88-6500

Facsimile : +81-478-82-3373

Radiated Spurious Emission

Test place Kashima EMC Lab. No.10 Semi Anechoic Chamber
Report No. 11242579M
Date April 28, 2016 May 9, 2016 May 9, 2016 May 10, 2016 May 25, 2016
Temperature / Humidity 22 deg. C 21 deg. C 21 deg. C 21 deg. C 23 deg. C
 40 % RH 52 % RH 52 % RH 55 % RH 52 % RH
Engineer Kazuhiro Ando Kazuhiro Ando Kazuhiro Ando Kazuhiro Ando Kazuhiro Ando
 (30-1000MHz) (1-10GHz) (10-18GHz) (18-26.5GHz) (1-26.5GHz)
Mode Tx, Hopping Off, DH5 2480 MHz

Polarity	Frequency [MHz]	Detector	Reading [dBuV]	Ant.Fac. [dB/m]	Loss [dB]	Gain [dB]	Distance Factor [dB]	Result [dBuV/m]	Limit [dBuV/m]	Margin [dB]	Height [cm]	Angle [deg]	Remark
Hori.	170.666	QP	28.7	13.0	6.0	26.4	0.0	21.3	43.5	22.2	160	140	
Hori.	536.372	QP	35.0	18.3	9.0	27.5	0.0	34.8	46.0	11.2	128	305	
Hori.	2365.160	PK	54.7	27.7	14.0	44.4	3.5	55.5	73.9	18.4	150	197	
Hori.	2483.500	PK	50.0	27.5	14.1	44.3	3.5	50.8	73.9	23.1	214	201	
Hori.	4960.000	PK	59.5	31.4	6.2	46.1	3.5	54.5	73.9	19.4	204	145	
Hori.	7440.000	PK	47.5	36.7	7.7	44.2	3.5	51.2	73.9	22.7	150	0	Floor noise
Hori.	2365.160	AV	36.9	27.7	14.0	44.4	3.5	37.7	53.9	16.2	150	197	
Hori.	2483.500	AV	37.7	27.5	14.1	44.3	3.5	38.5	53.9	15.4	214	201	
Hori.	4960.000	AV	53.0	31.4	6.2	46.1	3.5	48.0	53.9	5.9	204	145	
Hori.	7440.000	AV	35.9	36.7	7.7	44.2	3.5	39.6	53.9	14.3	150	0	Floor noise
Vert.	134.419	QP	35.7	12.8	5.6	26.5	0.0	27.6	43.5	15.9	100	260	
Vert.	195.050	QP	34.3	10.2	6.3	26.3	0.0	24.5	43.5	19.0	100	0	
Vert.	208.860	QP	28.3	9.8	6.4	26.2	0.0	18.3	43.5	25.2	100	350	
Vert.	536.390	QP	33.0	18.3	9.0	27.5	0.0	32.8	46.0	13.2	100	60	
Vert.	2386.540	PK	54.6	27.6	14.0	44.4	3.5	55.3	73.9	18.6	180	135	
Vert.	2483.500	PK	50.3	27.5	14.1	44.3	3.5	51.1	73.9	22.8	215	124	
Vert.	4960.000	PK	60.0	31.4	6.2	46.1	3.5	55.0	73.9	18.9	137	95	
Vert.	7440.000	PK	47.8	36.7	7.7	44.2	3.5	51.5	73.9	22.4	150	0	Floor noise
Vert.	2386.540	AV	37.1	27.6	14.0	44.4	3.5	37.8	53.9	16.1	180	135	
Vert.	2483.500	AV	37.5	27.5	14.1	44.3	3.5	38.3	53.9	15.6	215	124	
Vert.	4960.000	AV	54.0	31.4	6.2	46.1	3.5	49.0	53.9	4.9	137	95	
Vert.	7440.000	AV	35.9	36.7	7.7	44.2	3.5	39.6	53.9	14.3	150	0	Floor noise

Result = Reading + Ant.Fac. + Loss (Cable+(Attenuator or Filter)(below 18 GHz)) - Gain(Amplifier) + Distance factor

Distance factor : 1 GHz - 10 GHz : 20log (4.5 m / 3.0 m) = 3.5 dB

10 GHz - 26.5 GHz : 20log (1.0 m / 3.0 m) = -9.5 dB

* These results have sufficient margin without taking account Dwell time factor.

Radiated Spurious Emission
(Reference Plot for band-edge)

Test place	Kashima EMC Lab. No.10 Semi Anechoic Chamber
Report No.	11242579M
Date	May 9, 2016
Temperature / Humidity	21 deg. C / 52 % RH
Engineer	Kazuhiro Ando (1-10GHz)
Mode	Tx, Hopping Off, DH5 2480 MHz

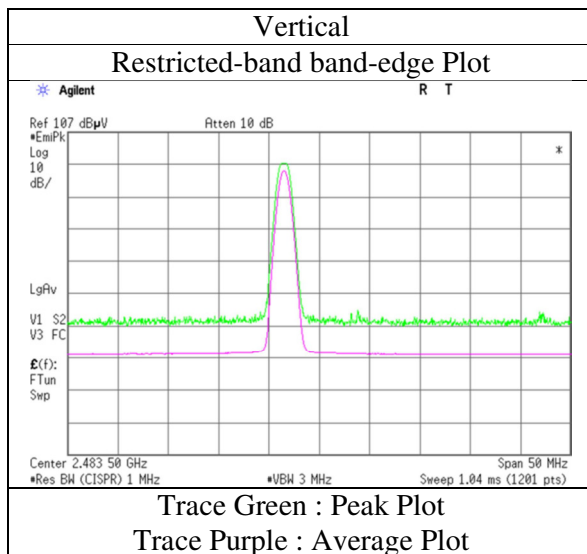
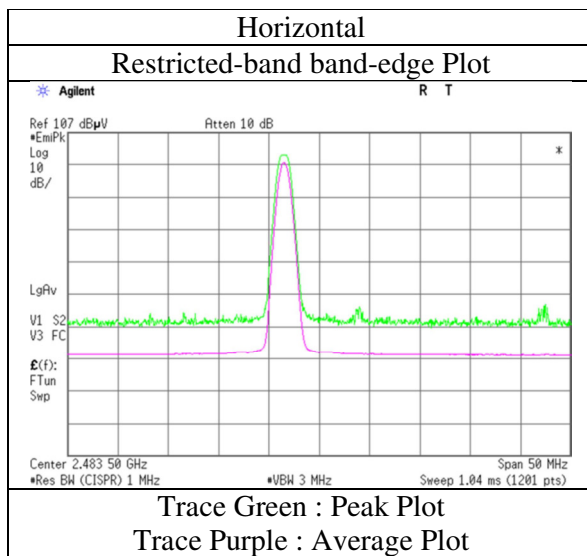

* Final result of restricted band edge was shown in tabular data.

Radiated Spurious Emission

Test place Kashima EMC Lab. No.10 Semi Anechoic Chamber
Report No. 11242579M
Date April 28, 2016 May 9, 2016 May 9, 2016 May 10, 2016 May 26, 2016
Temperature / Humidity 22 deg. C 21 deg. C 21 deg. C 21 deg. C 23 deg. C
 40 % RH 52 % RH 52 % RH 55 % RH 52 % RH
Engineer Kazuhiro Ando Kazuhiro Ando Kazuhiro Ando Kazuhiro Ando Kazuhiro Ando
 (30-1000MHz) (1-10GHz) (10-18GHz) (18-26.5GHz) (1-26.5GHz)
Mode Tx, Hopping Off, 3DH5 2402 MHz

Polarity	Frequency [MHz]	Detector	Reading [dBuV]	Ant.Fac. [dB/m]	Loss [dB]	Gain [dB]	Distance Factor [dB]	Result [dBuV/m]	Limit [dBuV/m]	Margin [dB]	Height [cm]	Angle [deg]	Remark
Hori.	121.904	QP	28.0	11.7	5.5	26.6	0.0	18.6	43.5	24.9	150	150	
Hori.	536.378	QP	32.9	18.3	9.0	27.5	0.0	32.7	46.0	13.3	132	310	
Hori.	2365.203	PK	55.3	27.7	14.0	44.4	3.5	56.1	73.9	17.8	160	205	
Hori.	2390.000	PK	52.8	27.6	14.0	44.4	3.5	53.5	73.9	20.4	165	215	
Hori.	3202.680	PK	58.8	28.9	5.6	44.5	3.5	52.3	73.9	21.6	140	215	
Hori.	4804.000	PK	57.1	31.3	6.1	46.1	3.5	51.9	73.9	22.0	145	150	
Hori.	7206.000	PK	50.3	36.3	7.5	44.7	3.5	52.9	73.9	21.0	150	0	Floor noise
Hori.	2365.203	AV	38.4	27.7	14.0	44.4	3.5	39.2	53.9	14.7	160	205	
Hori.	2390.000	AV	37.2	27.6	14.0	44.4	3.5	37.9	53.9	16.0	165	215	
Hori.	3202.680	AV	50.7	28.9	5.6	44.5	3.5	44.2	53.9	9.7	140	215	
Hori.	4804.000	AV	48.3	31.3	6.1	46.1	3.5	43.1	53.9	10.8	145	150	
Hori.	7206.000	AV	38.2	36.3	7.5	44.7	3.5	40.8	53.9	13.1	150	0	Floor noise
Vert.	134.418	QP	33.5	12.8	5.6	26.5	0.0	25.4	43.5	18.1	100	250	
Vert.	195.050	QP	34.6	10.2	6.3	26.3	0.0	24.8	43.5	18.7	100	0	
Vert.	205.540	QP	29.0	9.8	6.4	26.2	0.0	19.0	43.5	24.5	100	0	
Vert.	536.383	QP	34.3	18.3	9.0	27.5	0.0	34.1	46.0	11.9	100	71	
Vert.	2365.760	PK	54.6	27.7	14.0	44.4	3.5	55.4	73.9	18.5	175	243	
Vert.	2390.000	PK	51.7	27.6	14.0	44.4	3.5	52.4	73.9	21.5	190	240	
Vert.	3202.680	PK	55.9	28.9	5.6	44.5	3.5	49.4	73.9	24.5	170	240	
Vert.	4804.000	PK	59.4	31.3	6.1	46.1	3.5	54.2	73.9	19.7	170	180	
Vert.	7206.000	PK	50.6	36.3	7.5	44.7	3.5	53.2	73.9	20.7	150	0	Floor noise
Vert.	2365.760	AV	37.2	27.7	14.0	44.4	3.5	38.0	53.9	15.9	175	243	
Vert.	2390.000	AV	37.8	27.6	14.0	44.4	3.5	38.5	53.9	15.4	190	240	
Vert.	3202.680	AV	47.7	28.9	5.6	44.5	3.5	41.2	53.9	12.7	170	240	
Vert.	4804.000	AV	51.3	31.3	6.1	46.1	3.5	46.1	53.9	7.8	170	180	
Vert.	7206.000	AV	37.4	36.3	7.5	44.7	3.5	40.0	53.9	13.9	150	0	Floor noise

Result = Reading + Ant.Fac. + Loss (Cable+(Attenuator or Filter)(below 18 GHz)) - Gain(Amplifier) + Distance factor

Distance factor : 1 GHz - 10 GHz : $20\log(4.5\text{ m} / 3.0\text{ m}) = 3.5\text{ dB}$

10 GHz - 26.5 GHz : $20\log(1.0\text{ m} / 3.0\text{ m}) = -9.5\text{ dB}$

* These results have sufficient margin without taking account Dwell time factor.

20 dBc Data Sheet (RBW 100 kHz, VBW 300 kHz)

Polarity	Frequency [MHz]	Detector	Reading [dBuV]	Ant.Fac. [dB/m]	Loss [dB]	Gain [dB]	Distance Factor [dB]	Result [dBuV/m]	Limit [dBuV/m]	Margin [dB]	Remark
Hori.	2402.000	PK	97.0	27.6	14.0	44.4	3.5	97.7	-	-	Carrier
Hori.	2400.000	PK	47.2	27.6	14.0	44.4	3.5	47.9	77.7	29.8	
Vert.	2402.000	PK	94.1	27.6	14.0	44.4	3.5	94.8	-	-	Carrier
Vert.	2400.000	PK	44.9	27.6	14.0	44.4	3.5	45.6	74.8	29.2	

Result = Reading + Ant.Fac. + Loss (Cable+(Attenuator or Filter)(below 18 GHz)) - Gain(Amplifier) + Distance factor

Distance factor : 1 GHz - 10 GHz : $20\log(4.5\text{ m} / 3.0\text{ m}) = 3.5\text{ dB}$

10 GHz - 26.5 GHz : $20\log(1.0\text{ m} / 3.0\text{ m}) = -9.5\text{ dB}$

*These results have sufficient margin without taking account Dwell time factor.

Radiated Spurious Emission
(Reference Plot for band-edge)

Test place	Kashima EMC Lab. No.10 Semi Anechoic Chamber
Report No.	11242579M
Date	May 9, 2016
Temperature / Humidity	21 deg. C / 52 % RH
Engineer	Kazuhiro Ando (1-10GHz)
Mode	Tx, Hopping Off, 3DH5 2402 MHz

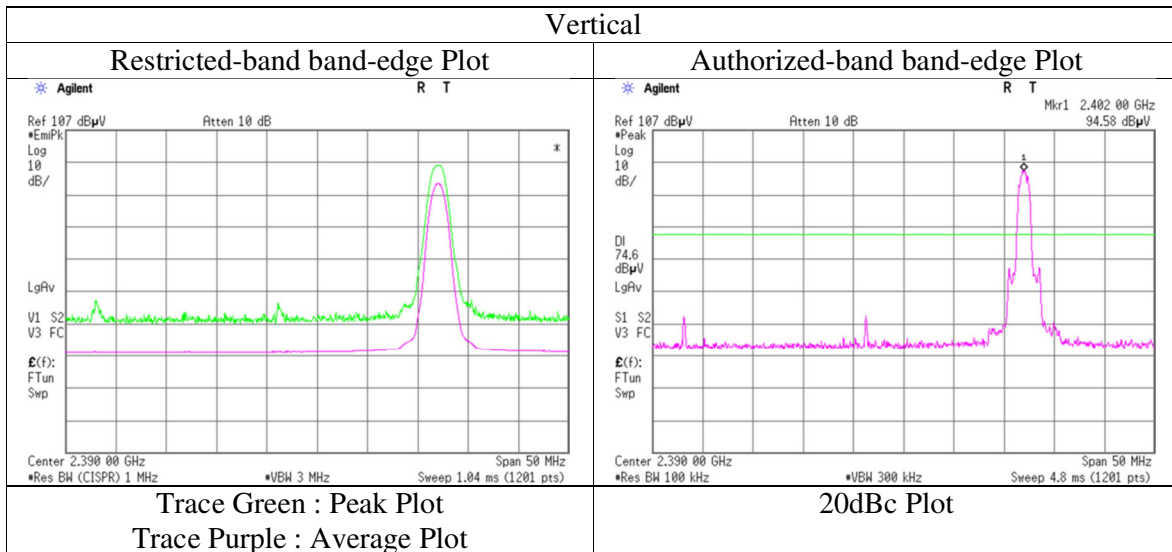
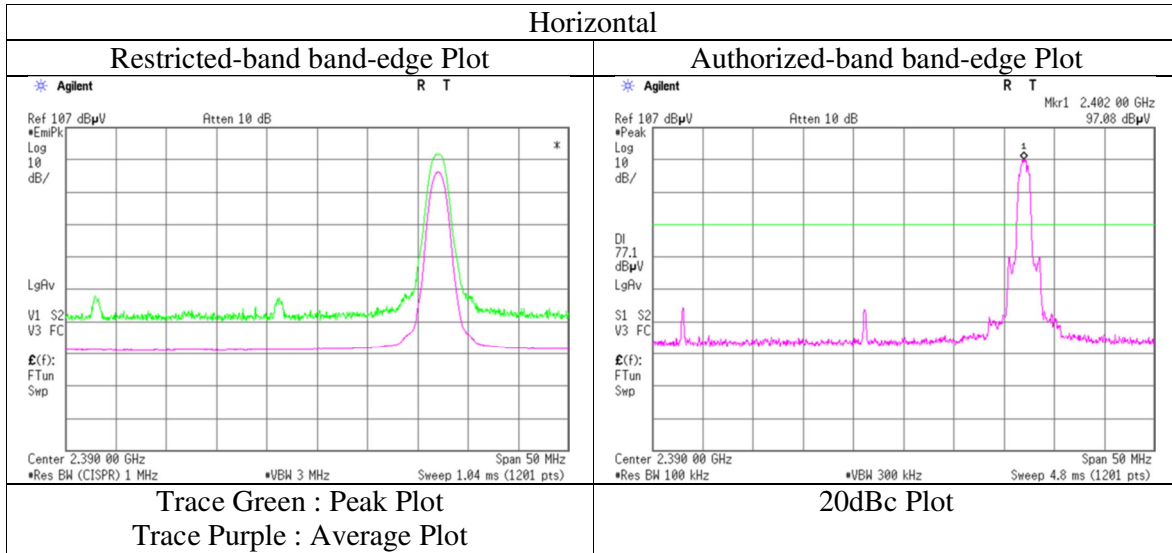

* Final result of restricted band edge was shown in tabular data.

Radiated Spurious Emission

Test place Kashima EMC Lab. No.10 Semi Anechoic Chamber
Report No. 11242579M
Date April 28, 2016 May 9, 2016 May 9, 2016 May 10, 2016 May 26, 2016
Temperature / Humidity 22 deg. C 21 deg. C 21 deg. C 21 deg. C 23 deg. C
 40 % RH 52 % RH 52 % RH 55 % RH 52 % RH
Engineer Kazuhiro Ando Kazuhiro Ando Kazuhiro Ando Kazuhiro Ando Kazuhiro Ando
 (30-1000MHz) (1-10GHz) (10-18GHz) (18-26.5GHz) (1-26.5GHz)
Mode Tx, Hopping Off, 3DH5 2441 MHz

Polarity	Frequency [MHz]	Detector	Reading [dBuV]	Ant.Fac. [dB/m]	Loss [dB]	Gain [dB]	Distance Factor [dB]	Result [dBuV/m]	Limit [dBuV/m]	Margin [dB]	Height [cm]	Angle [deg]	Remark
Hori.	121.905	QP	29.0	11.7	5.5	26.6	0.0	19.6	43.5	23.9	166	160	
Hori.	536.381	QP	33.5	18.3	9.0	27.5	0.0	33.3	46.0	12.7	130	312	
Hori.	2386.950	PK	54.5	27.6	14.0	44.4	3.5	55.2	73.9	18.7	185	223	
Hori.	4882.000	PK	59.1	31.2	6.2	46.1	3.5	53.9	73.9	20.0	160	162	
Hori.	7323.000	PK	48.1	36.5	7.8	44.4	3.5	51.5	73.9	22.4	100	0	Floor noise
Hori.	2386.950	AV	36.9	27.6	14.0	44.4	3.5	37.6	53.9	16.3	185	223	
Hori.	4882.000	AV	50.4	31.2	6.2	46.1	3.5	45.2	53.9	8.7	160	162	
Hori.	7323.000	AV	35.9	36.5	7.8	44.4	3.5	39.3	53.9	14.6	100	0	Floor noise
Vert.	121.909	QP	30.3	11.7	5.5	26.6	0.0	20.9	43.5	22.6	100	280	
Vert.	195.050	QP	34.5	10.2	6.3	26.3	0.0	24.7	43.5	18.8	100	0	
Vert.	205.498	QP	27.7	9.8	6.4	26.2	0.0	17.7	43.5	25.8	100	0	
Vert.	536.379	QP	34.5	18.3	9.0	27.5	0.0	34.3	46.0	11.7	100	71	
Vert.	2364.630	PK	54.7	27.7	14.0	44.4	3.5	55.5	73.9	18.4	141	135	
Vert.	4882.000	PK	61.2	31.2	6.2	46.1	3.5	56.0	73.9	17.9	144	81	
Vert.	7323.000	PK	47.8	36.5	7.8	44.4	3.5	51.2	73.9	22.7	150	0	Floor noise
Vert.	2364.630	AV	36.9	27.7	14.0	44.4	3.5	37.7	53.9	16.2	141	135	
Vert.	4882.000	AV	53.1	31.2	6.2	46.1	3.5	47.9	53.9	6.0	144	81	
Vert.	7323.000	AV	35.9	36.5	7.8	44.4	3.5	39.3	53.9	14.6	150	0	Floor noise

Result = Reading + Ant.Fac. + Loss (Cable+(Attenuator or Filter)(below 18 GHz)) - Gain(Amplifier) + Distance factor

Distance factor : 1 GHz - 10 GHz : 20log (4.5 m / 3.0 m) = 3.5 dB

10 GHz - 26.5 GHz : 20log (1.0 m / 3.0 m) = -9.5 dB

* These results have sufficient margin without taking account Dwell time factor.

UL Japan, Inc.

Kashima EMC Lab.

1614, Mushihata, Katori-shi, Chiba-ken, 289-0341 Japan

Telephone : +81-478-88-6500

Facsimile : +81-478-82-3373

Radiated Spurious Emission

Test place Kashima EMC Lab. No.10 Semi Anechoic Chamber
Report No. 11242579M
Date April 28, 2016 May 9, 2016 May 9, 2016 May 10, 2016 May 26, 2016
Temperature / Humidity 22 deg. C 21 deg. C 21 deg. C 21 deg. C 23 deg. C
 40 % RH 52 % RH 52 % RH 55 % RH 52 % RH
Engineer Kazuhiro Ando Kazuhiro Ando Kazuhiro Ando Kazuhiro Ando Kazuhiro Ando
 (30-1000MHz) (1-10GHz) (10-18GHz) (18-26.5GHz) (1-26.5GHz)
Mode Tx, Hopping Off, 3DH5 2480 MHz

Polarity	Frequency [MHz]	Detector	Reading [dBuV]	Ant.Fac. [dB/m]	Loss [dB]	Gain [dB]	Distance Factor [dB]	Result [dBuV/m]	Limit [dBuV/m]	Margin [dB]	Height [cm]	Angle [deg]	Remark
Hori.	170.674	QP	27.5	13.0	6.0	26.4	0.0	20.1	43.5	23.4	152	120	
Hori.	536.372	QP	33.7	18.3	9.0	27.5	0.0	33.5	46.0	12.5	155	169	
Hori.	2365.510	PK	56.2	27.7	14.0	44.4	3.5	57.0	73.9	16.9	167	240	
Hori.	2483.500	PK	54.9	27.5	14.1	44.3	3.5	55.7	73.9	18.2	159	209	
Hori.	4960.000	PK	59.5	31.4	6.2	46.1	3.5	54.5	73.9	19.4	208	145	
Hori.	7440.000	PK	47.8	36.7	7.7	44.2	3.5	51.5	73.9	22.4	150	0	Floor noise
Hori.	2365.510	AV	36.9	27.7	14.0	44.4	3.5	37.7	53.9	16.2	167	240	
Hori.	2483.500	AV	39.5	27.5	14.1	44.3	3.5	40.3	53.9	13.6	159	209	
Hori.	4960.000	AV	51.0	31.4	6.2	46.1	3.5	46.0	53.9	7.9	208	145	
Hori.	7440.000	AV	35.9	36.7	7.7	44.2	3.5	39.6	53.9	14.3	150	0	Floor noise
Vert.	134.425	QP	30.7	12.8	5.6	26.5	0.0	22.6	43.5	20.9	100	280	
Vert.	195.050	QP	35.0	10.2	6.3	26.3	0.0	25.2	43.5	18.3	100	0	
Vert.	207.183	QP	30.0	9.8	6.4	26.2	0.0	20.0	43.5	23.5	100	0	
Vert.	536.385	QP	34.5	18.3	9.0	27.5	0.0	34.3	46.0	11.7	100	65	
Vert.	2364.900	PK	55.2	27.7	14.0	44.4	3.5	56.0	73.9	17.9	186	134	
Vert.	2483.500	PK	54.4	27.5	14.1	44.3	3.5	55.2	73.9	18.7	216	125	
Vert.	4960.000	PK	60.4	31.4	6.2	46.1	3.5	55.4	73.9	18.5	156	85	
Vert.	7440.000	PK	47.7	36.7	7.7	44.2	3.5	51.4	73.9	22.5	150	0	Floor noise
Vert.	2364.900	AV	36.9	27.7	14.0	44.4	3.5	37.7	53.9	16.2	186	134	
Vert.	2483.500	AV	39.2	27.5	14.1	44.3	3.5	40.0	53.9	13.9	216	125	
Vert.	4960.000	AV	52.3	31.4	6.2	46.1	3.5	47.3	53.9	6.6	156	85	
Vert.	7440.000	AV	35.8	36.7	7.7	44.2	3.5	39.5	53.9	14.4	150	0	Floor noise

Result = Reading + Ant.Fac. + Loss (Cable+(Attenuator or Filter)(below 18 GHz)) - Gain(Amplifier) + Distance factor

Distance factor : 1 GHz - 10 GHz : 20log(4.5 m / 3.0 m) = 3.5 dB

10 GHz - 26.5 GHz : 20log(1.0 m / 3.0 m) = -9.5 dB

* These results have sufficient margin without taking account Dwell time factor.

Radiated Spurious Emission
(Reference Plot for band-edge)

Test place	Kashima EMC Lab. No.10 Semi Anechoic Chamber
Report No.	11242579M
Date	May 9, 2016
Temperature / Humidity	21 deg. C / 52 % RH
Engineer	Kazuhiro Ando (1-10GHz)
Mode	Tx, Hopping Off, 3DH5 2480 MHz

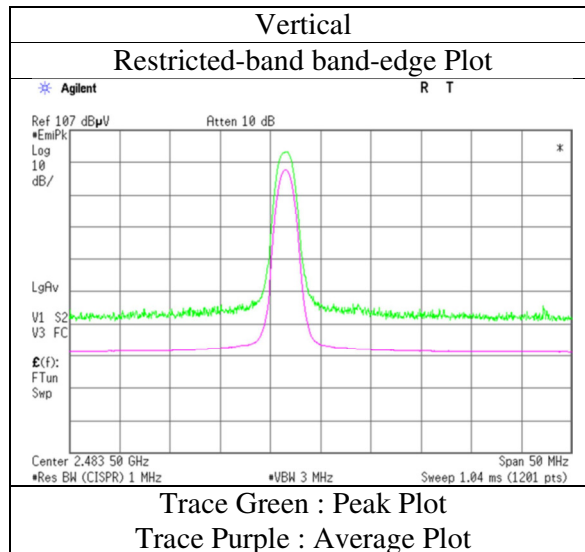
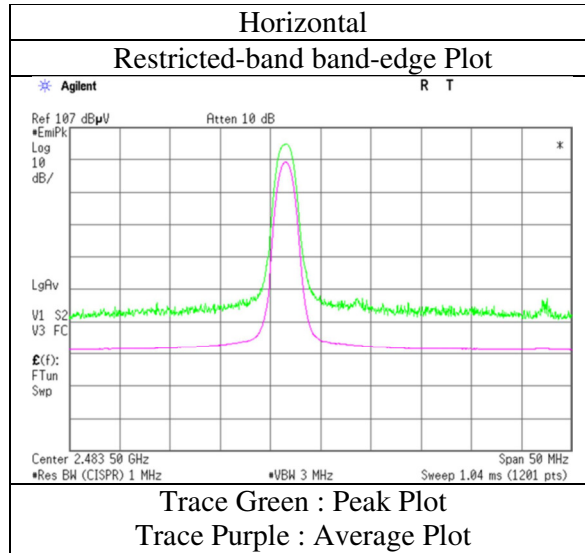

* Final result of restricted band edge was shown in tabular data.

Radiated Spurious Emission
(Plot data, Worst case)

Test place	Kashima EMC Lab. No.10 Semi Anechoic Chamber			
Report No.	11242579M			
Date	April 28, 2016	May 9, 2016	May 9, 2016	May 10, 2016
Temperature / Humidity	22 deg. C / 40 % RH	21 deg. C / 52 % RH	21 deg. C / 52 % RH	21 deg. C / 55 % RH
Engineer	Kazuhiro Ando	Kazuhiro Ando	Kazuhiro Ando	Kazuhiro Ando
	(30-1000MHz)	(1-10GHz)	(10-18GHz)	(18-26.5GHz)
Mode	Tx, Hopping Off, DH5 2441 MHz			

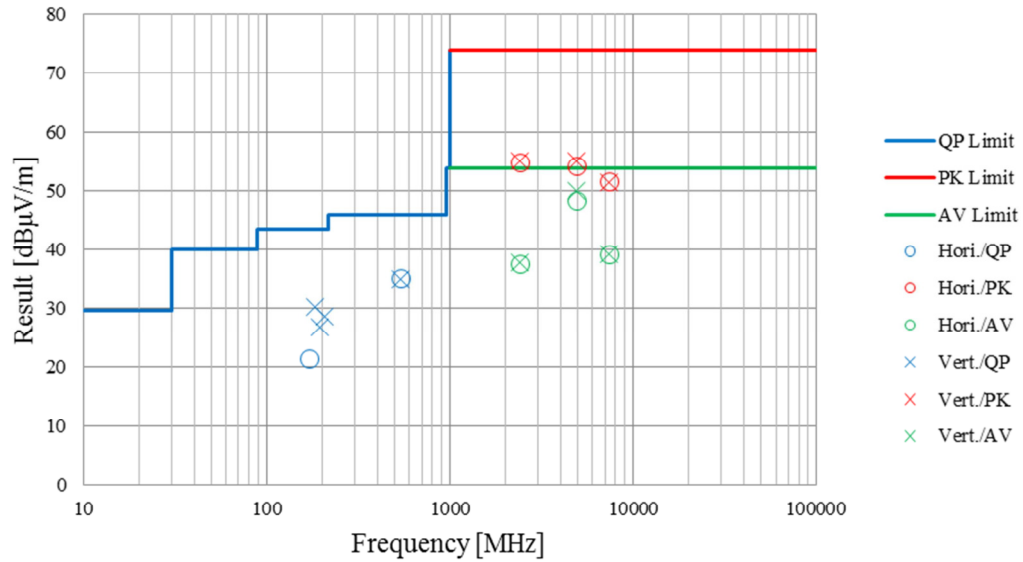

*These plots data contains sufficient number to show the trend of characteristic features for EUT.

Conducted Spurious Emission

Test place	Kashima EMC Lab. No.2 Measurement Room
Report No.	11242579M
Date	April 27, 2016
Temperature / Humidity	22 deg. C / 55 % RH
Engineer	Kazuhiro Ando
Mode	Tx, Hopping Off, DH5

2402 MHz

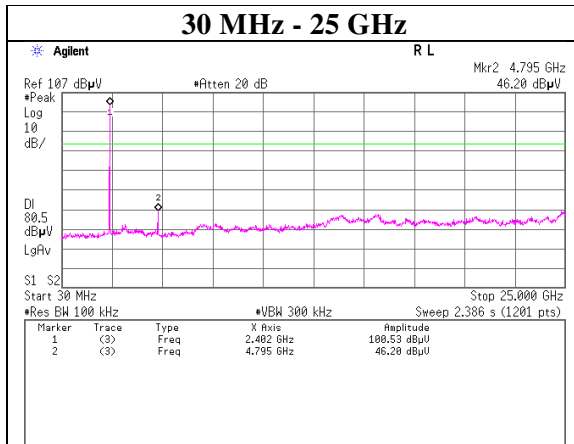
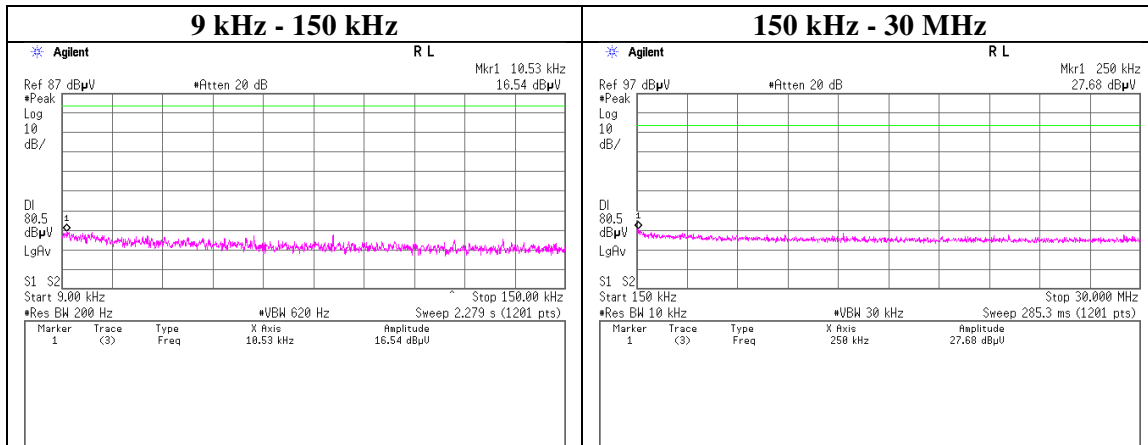

UL Japan, Inc.

Kashima EMC Lab.

1614, Mushihata, Katori-shi, Chiba-ken, 289-0341 Japan

Telephone : +81-478-88-6500

Facsimile : +81-478-82-3373

Conducted Spurious Emission

Test place	Kashima EMC Lab. No.2 Measurement Room
Report No.	11242579M
Date	April 27, 2016
Temperature / Humidity	22 deg. C / 55 % RH
Engineer	Kazuhiro Ando
Mode	Tx, Hopping Off, DH5

2441 MHz

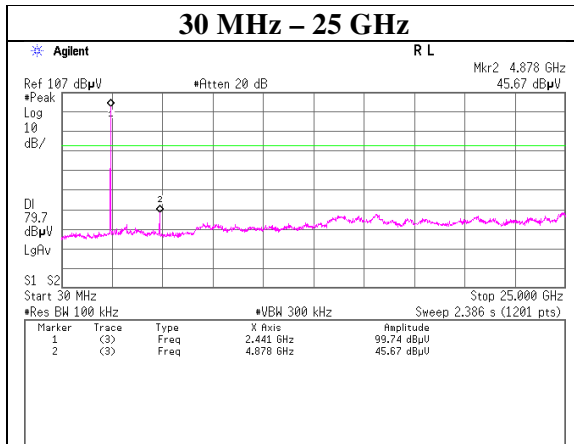
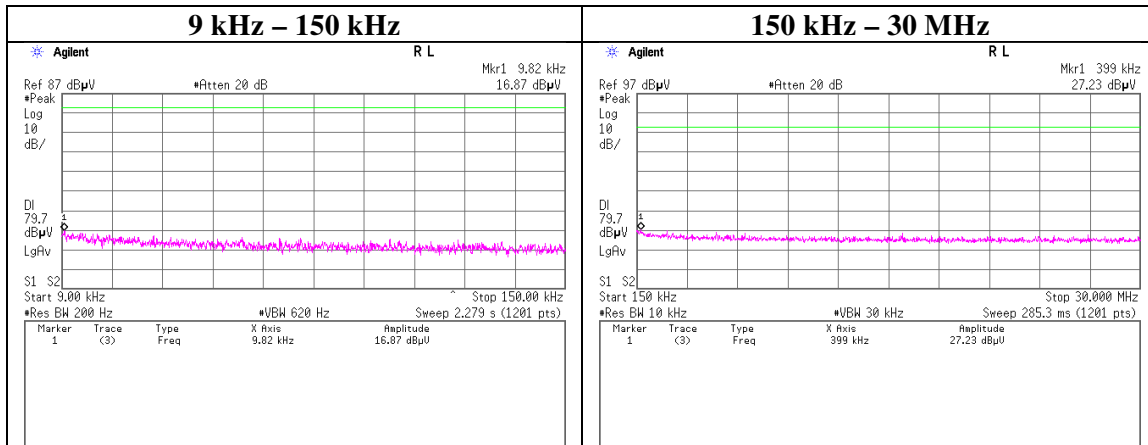

Conducted Spurious Emission

Test place	Kashima EMC Lab. No.2 Measurement Room
Report No.	11242579M
Date	April 27, 2016
Temperature / Humidity	22 deg. C / 55 % RH
Engineer	Kazuhiro Ando
Mode	Tx, Hopping Off, DH5

2480 MHz

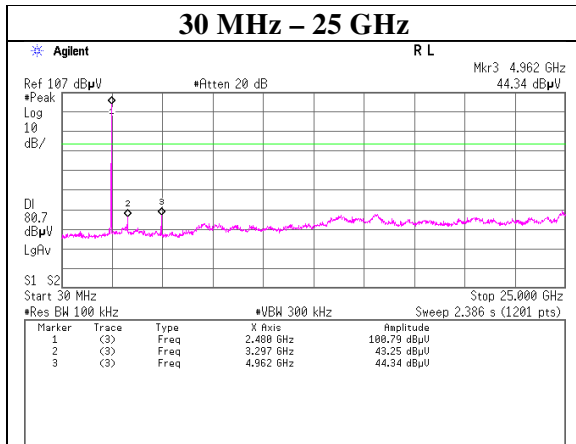
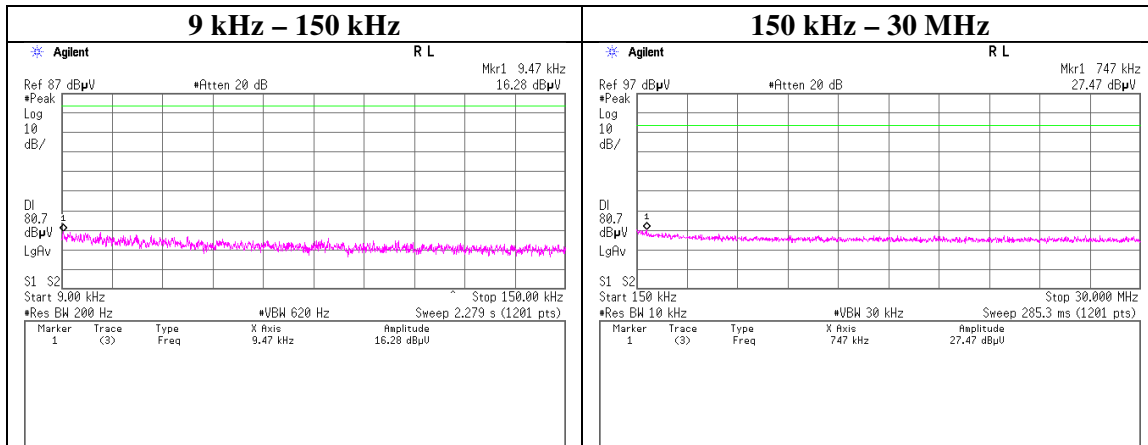

Conducted Spurious Emission

Test place	Kashima EMC Lab. No.2 Measurement Room
Report No.	11242579M
Date	April 27, 2016
Temperature / Humidity	22 deg. C / 55 % RH
Engineer	Kazuhiro Ando
Mode	Tx, Hopping Off, 3DH5

2402 MHz

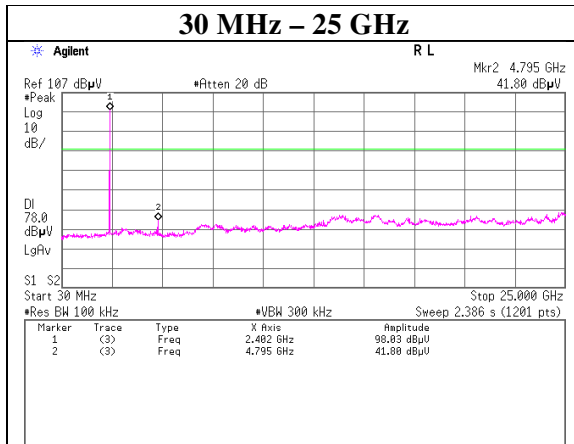
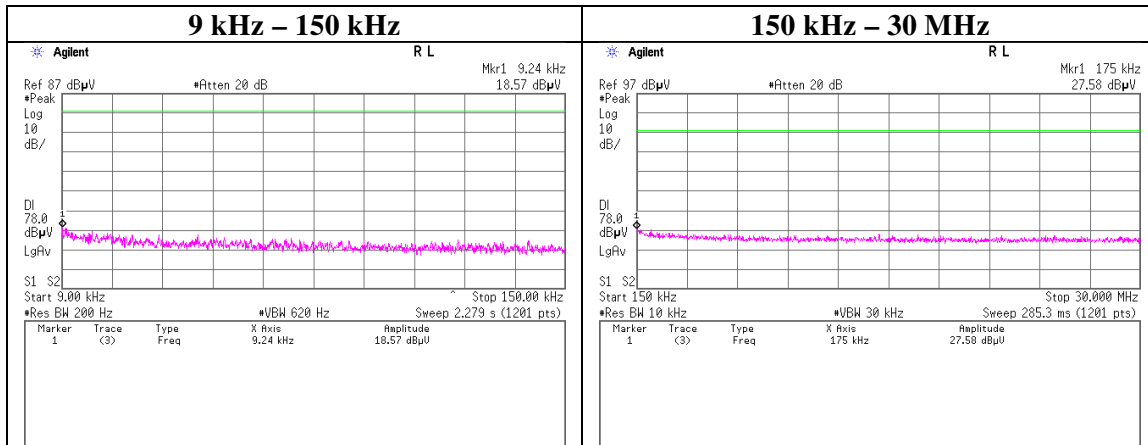

Conducted Spurious Emission

Test place	Kashima EMC Lab. No.2 Measurement Room
Report No.	11242579M
Date	April 27, 2016
Temperature / Humidity	22 deg. C / 55 % RH
Engineer	Kazuhiro Ando
Mode	Tx, Hopping Off, 3DH5

2441 MHz

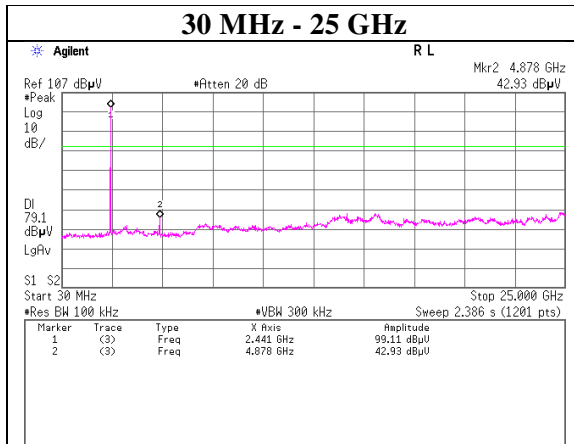
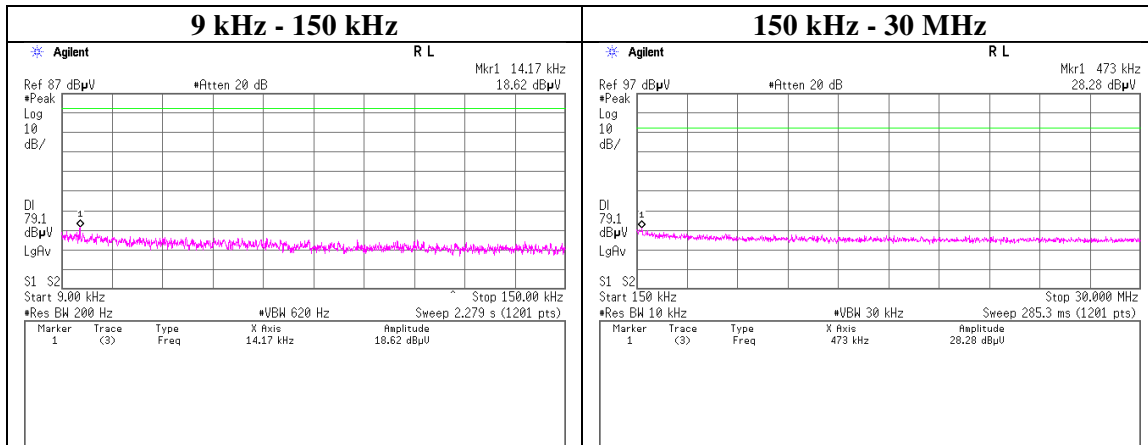

Conducted Spurious Emission

Test place	Kashima EMC Lab. No.2 Measurement Room
Report No.	11242579M
Date	April 27, 2016
Temperature / Humidity	22 deg. C / 55 % RH
Engineer	Kazuhiro Ando
Mode	Tx, Hopping Off, 3DH5

2480 MHz

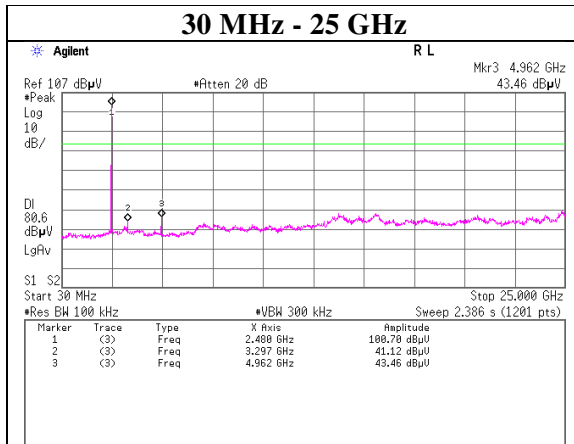

Conducted Emission Band Edge compliance

Test place	Kashima EMC Lab. No.2 Measurement Room
Report No.	11242579M
Date	April 27, 2016
Temperature / Humidity	22 deg. C / 55 % RH
Engineer	Kazuhiro Ando
Mode	Tx DH5

Hopping On

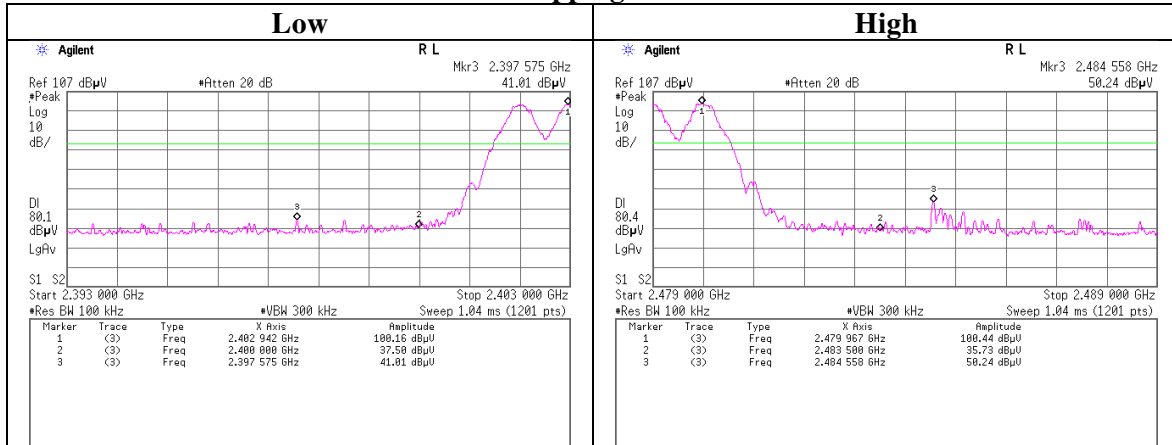

Hopping Off

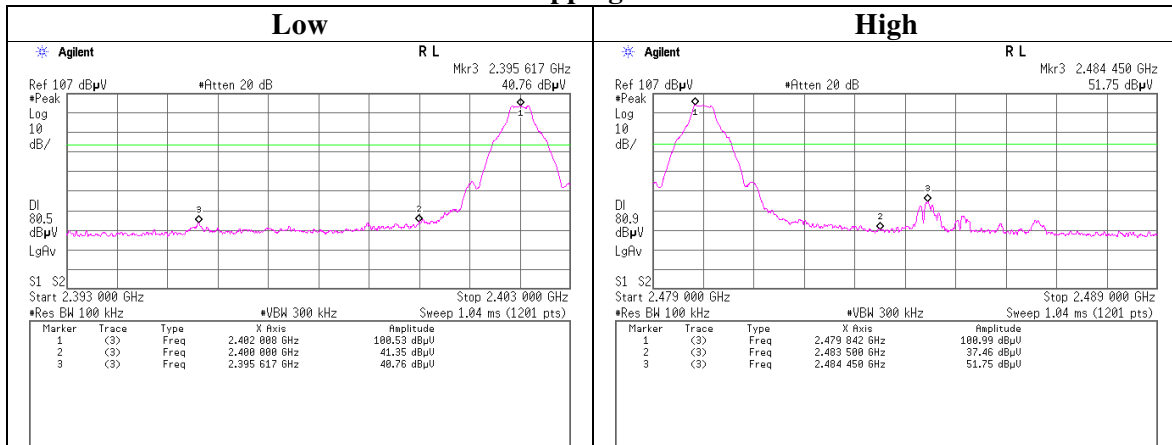

Conducted Emission Band Edge compliance

Test place : Kashima EMC Lab. No.2 Measurement Room
 Report No. : 11242579M
 Date : April 27, 2016
 Temperature / Humidity : 22 deg. C / 55 % RH
 Engineer : Kazuhiro Ando
 Mode : Tx 3DH5

Hopping On

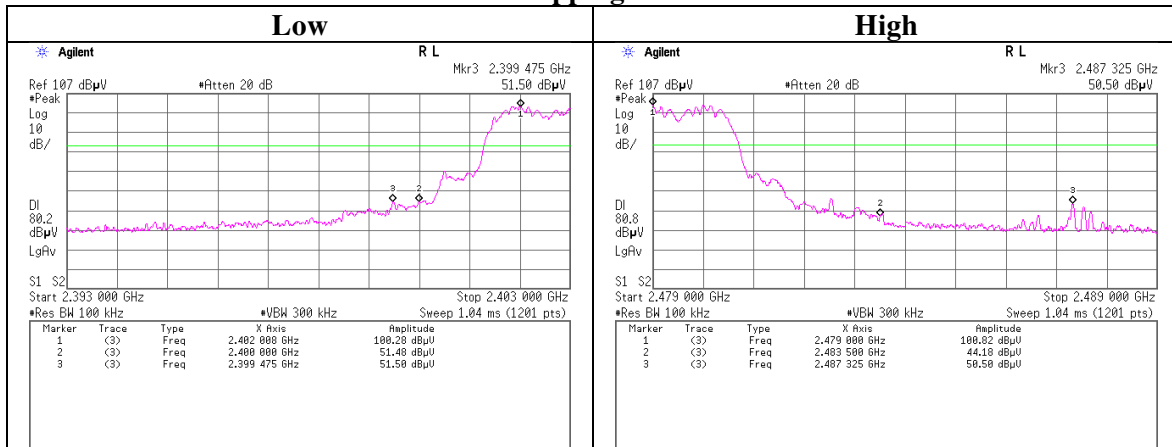

Hopping Off

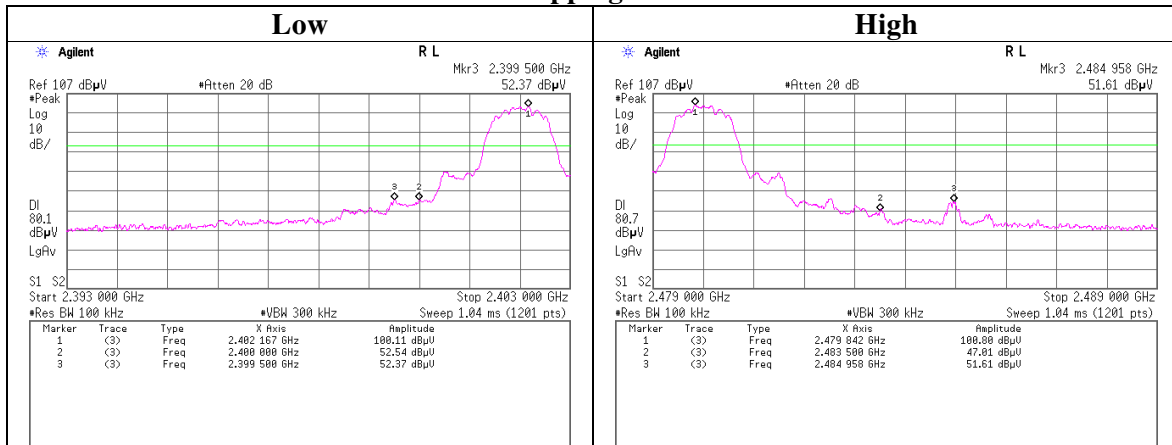

99% Occupied Bandwidth

Test place	Kashima EMC Lab. No.2 Measurement Room
Report No.	11242579M
Date	April 27, 2016
Temperature / Humidity	22 deg. C / 55 % RH
Engineer	Kazuhiro Ando
Mode	Tx Hopping Off

Hopping Off, DH5

Hopping Off, 3DH5

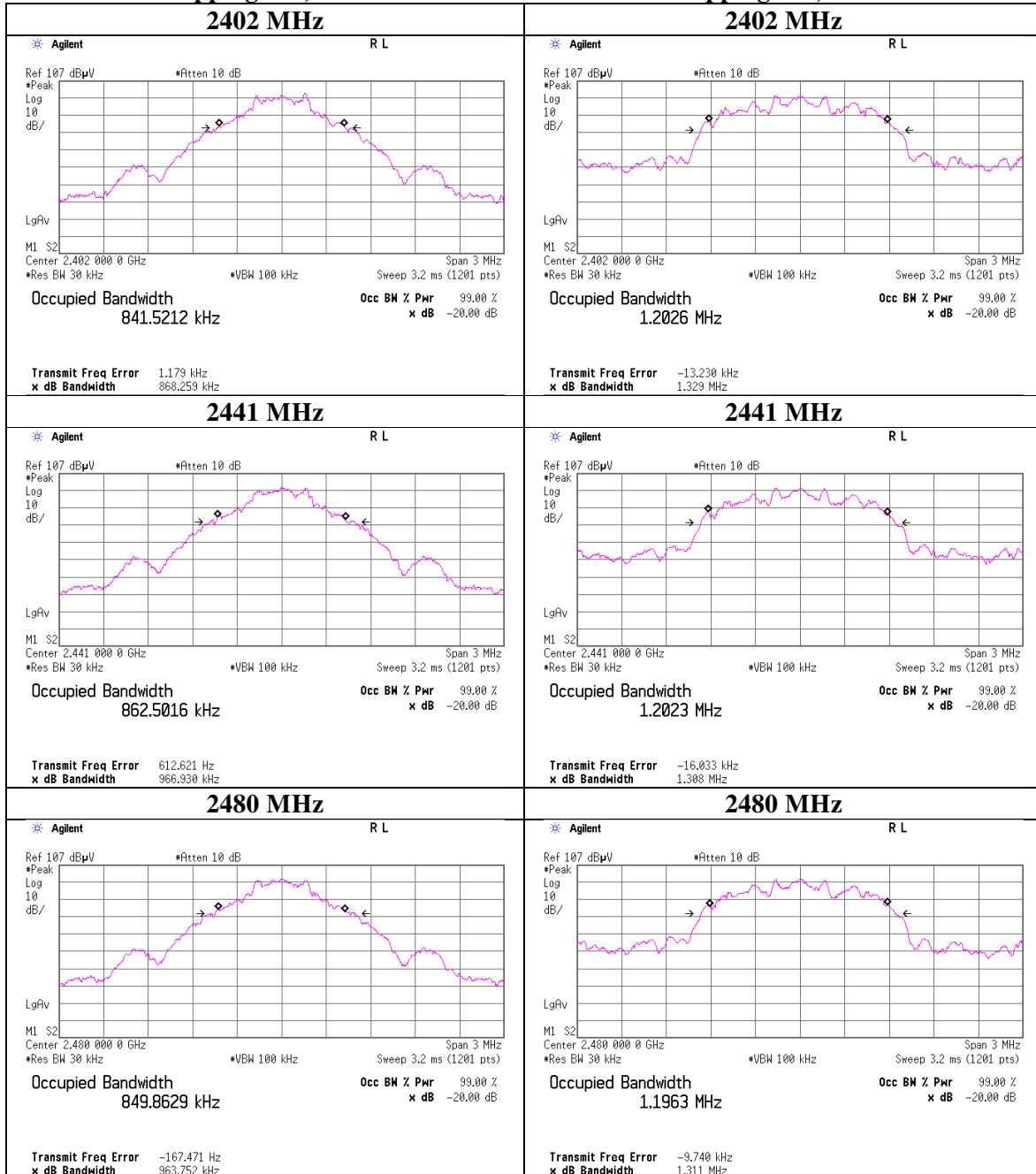

99% Occupied Bandwidth

Test place	Kashima EMC Lab. No.2 Measurement Room
Report No.	11242579M
Date	April 27, 2016
Temperature / Humidity	22 deg. C / 55 % RH
Engineer	Kazuhiro Ando
Mode	Tx Hopping On

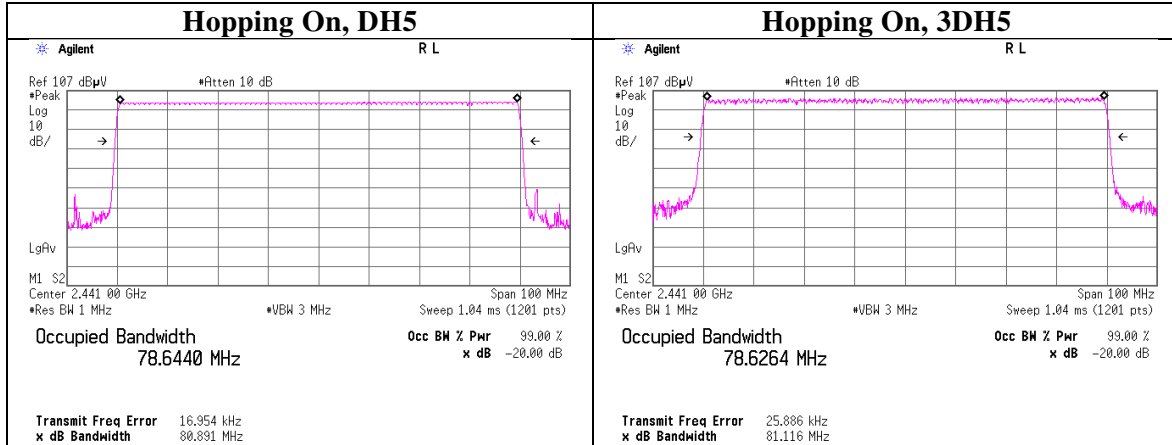

APPENDIX 2: Test instruments

Test equipment

Control No.	Instrument	Manufacturer	Model No	Serial No	Test Item	Calibration Date * Interval(month)
CSA-07	Spectrum Analyzer	Agilent	E4448A	MY52490024 Version A.11.21	AT	2015/05/28 * 12
CAT10-17	10dB Fixed Atten.	Weinschel	54A-10	56251	AT	2015/05/26 * 12
CCC-W01	Micro Wave Cable	SUHNER	SUCOFLEX102	MY3662/2	AT	2015/05/26 * 12
CPM-16	Peak Power Analyzer	Agilent	8990B	MY51000276	AT	2015/06/16 * 12
CPSO-24	Power Sensor	Agilent	N1923A	MY54070024	AT	2015/06/16 * 12
COS-12	Temperature & Humidity Indicator	A&D	AD-5681	6876017	AT	2015/07/13 * 12
CLS-25	A.M.N.	Rohde & Schwarz	ENV216	101042	CE	2015/08/06 * 12
CCC-S2-C(2/ 6/7/8)	Coaxial Cable	Fujikura,Fujikura, Fujikura,Fujikura	5D-2W,5D-2W,5 D-2W,5D-2W	-	CE	2015/07/14 * 12
CTM-32	Terminator	Suhner	65_BNC-50-0-2/ 133_NE	none	CE	2015/11/19 * 12
CTR-05	Test Receiver	Rohde & Schwarz	ESCI	100608 Rev 4.32	CE	2015/09/24 * 12
CSCL-02	Ruler	Tajima	L19-55	none	CE	2016/02/22 * 12
COS-02	Temperature & Humidity Indicator	A&D	AD-5681	6878345	CE	2015/07/13 * 12
CTS-06	Digital Multimeter	FLUKE	112	89790159	CE	2015/09/08 * 12
CTR-09	Test Receiver	Agilent	N9038A	MY53290016 Version A.14.03	RE	2015/06/28 * 12
CBL-08	LOGBICON	Schwarzbeck	VULB 9168	343	RE	2015/11/15 * 12
CAT3-04	3dB Fixed Atten.	TAMAGAWA	UFA-01	none	RE	2015/09/03 * 12
CCC-S10-R(2/4/CATS-11 /5/6/7/8/11/1 2)	Coaxial Cable	Fujikura,Fujikura, Agilent,Fujikura,F ujikura,Fujikura,F uhjikura,Fujikura, Fujikura	5D-2W,5D-2W,8 494A,5D-2W,5D -2W,5D-2W,5D- 2W,5D-2W,5D-2 W	MY41110200(St ep Att)	RE	2015/08/11 * 12
CAF-08	Pre-Amplifier	Hewlett Packard	8447D	2944A09041	RE	2015/08/11 * 12
CSCL-13	Ruler	Tajima	L19-55	none	RE	2016/02/22 * 12
COS-10	Temperature & Humidity Indicator	HIOKI	3641/9680-50	090999895/0909 05406	RE	2015/05/17 * 12
CTS-14	Digital Multimeter	FLUKE	115	994460954	RE	2015/10/01 * 12
COTS-CEMI -02	EMI Software	TSJ	TEPTO-DV(RE, CE,MF,PE)	Ver, RE: 2.5.0131, CE: 2.5.0131	RE	-

UL Japan, Inc.

Kashima EMC Lab.

1614, Mushihata, Katori-shi, Chiba-ken, 289-0341 Japan

Telephone : +81-478-88-6500

Facsimile : +81-478-82-3373

Control No.	Instrument	Manufacturer	Model No	Serial No	Test Item	Calibration Date * Interval(month)
CSA-06	Spectrum Analyzer	Agilent	N9030A	MY53310670 Version A.13.12	RE	2015/05/28 * 12
CSA-07	Spectrum Analyzer	Agilent	E4448A	MY52490024 Version A.11.21	RE	2015/05/28 * 12
CHA-20	Broad Band Horn	Schwarzbeck	BBHA 9120D	9120D-1270	RE	2015/07/31 * 12
CHA-07	Double Ridged Horn	ETS-Lindgren	3160-09	00166043	RE	2015/06/28 * 12
CAF-21	Pre-Amplifier	Micro Wave Factory	MPR-1G26.5-35	161398	RE	2016/05/06 * 12
CAF-19	Pre-Amplifier	TOYO	HAP18-26W	00000035	RE	2015/06/28 * 12
CAT10-16	10dB Fixed Atten.	Weinschel	54A-10	56246	RE	2015/05/26 * 12
CHF-03	HPF	Micro-Tronics	HPM50111-02	008	RE	2015/05/25 * 12
CCC-W05	Micro Wave Cable	Junkosha	MWX241	MRA-12-14-145	RE	2015/05/26 * 12
CCC-W07	Micro Wave Cable	Junkosha	MWX221	MRA-12-14-148	RE	2015/05/26 * 12
CCC-W09	Micro Wave Cable	SUHNER	SUCOFLEX104	MY588/4	RE	2015/07/13 * 12

**The expiration date of the calibration is the end of the expired month.
All equipment is calibrated with valid calibrations. Each measurement data is traceable to the national or international standards.**

As for some calibrations performed after the tested dates, those test equipment have been controlled by means of an unbroken chains of calibrations.

**Test Item: CE: Conducted Emission test
RE: Radiated Emission test
AT: Antenna Terminal Conducted test**