

APPENDIX 1: Photographs of EUT and SAR test setup

Appendix 1-1: Photograph of EUT and antenna position

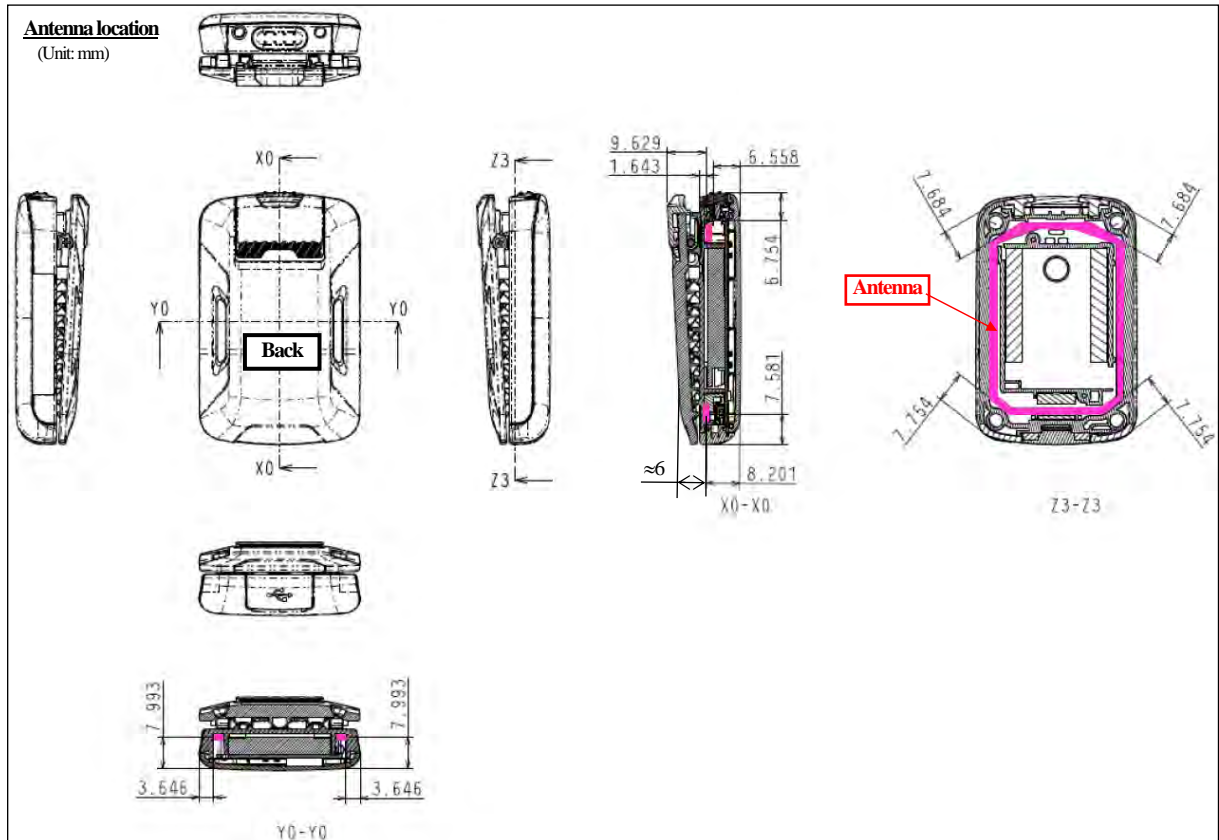

Appendix 1-2: EUT and support equipment

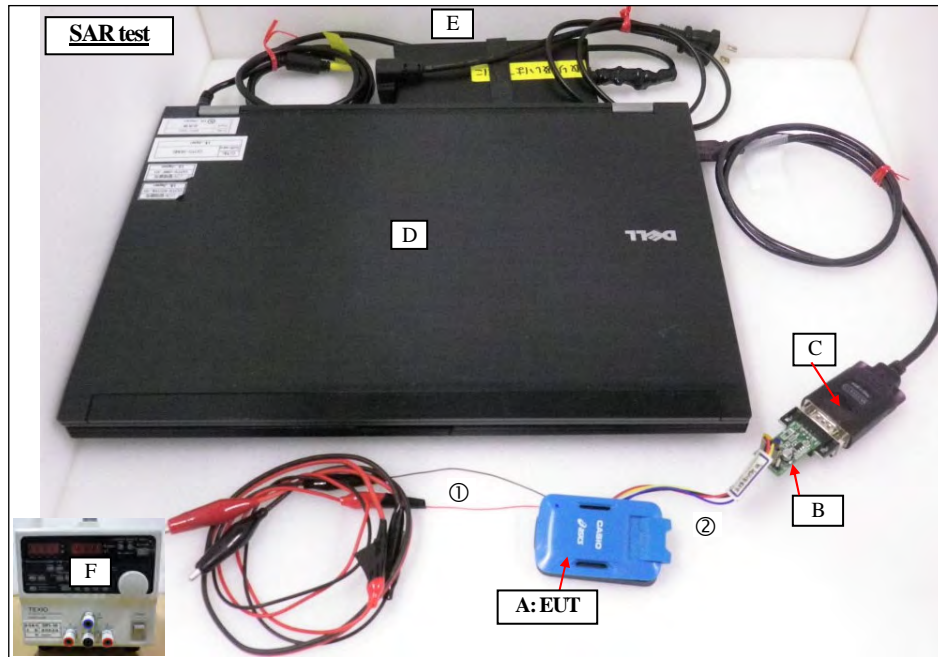















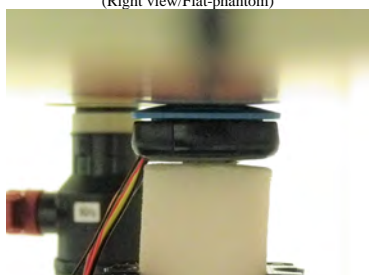

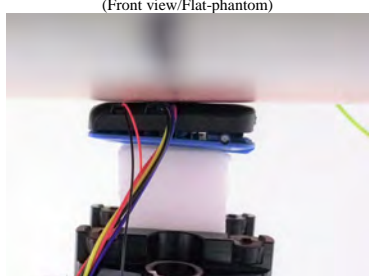
Description of EUT and Support Equipment

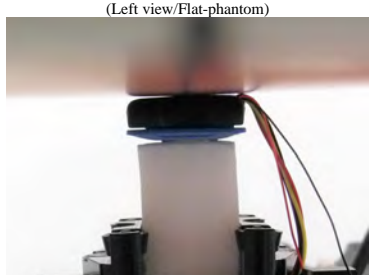
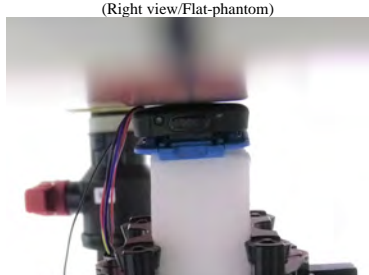
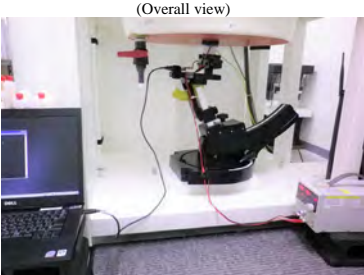
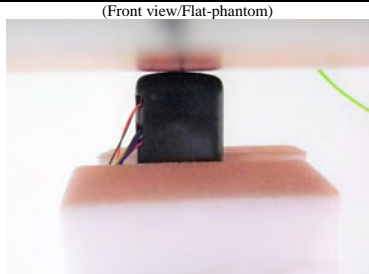
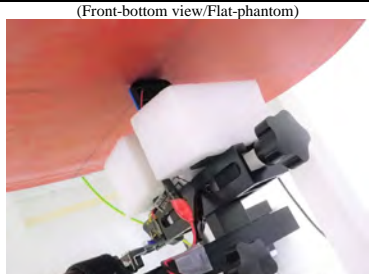
No.	Item	Model number	Serial number	Manufacturer	Remark
A	Motion Sensor	CMT-S20R-AS	CS1-033	CASIO COMPUTER CO., LTD.	EUT
B	Jig PCB	-	-	CASIO COMPUTER CO., LTD.	Support equipment.
C	USB-serial cable	BSUSRC0610BS	0064173	BUFFALO	Support equipment. with 1 m shield cable
D	Laptop PC (ctrl#:SPC-S03)	Latitude E6500	30326706285	DELL	Support equipment. (Host PC)
E	AC Adaptor (for item D, Laptop PC)	FA90PE0-00	-	DELL	Support equipment. DC cable: 1.7m, AC cable: 0.9m
F	DC power supply	PW16-5ADO	18026330	TEXIO	Support equipment. DC 3.7 V (ctrl#:SDPS-06)

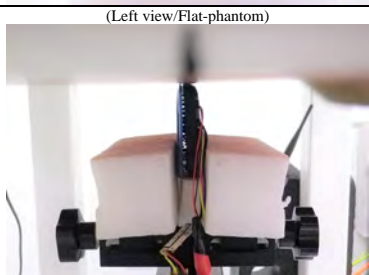

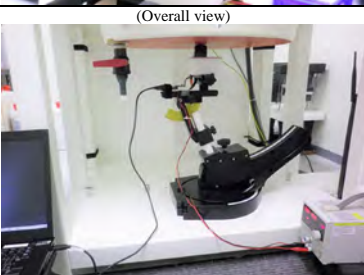
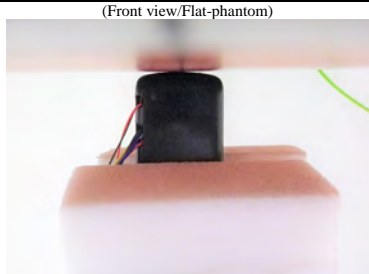
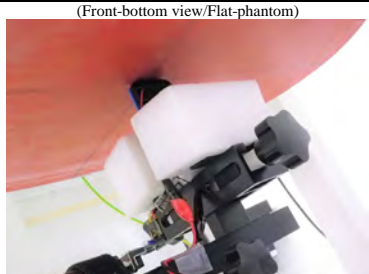

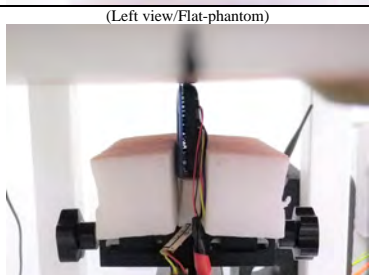

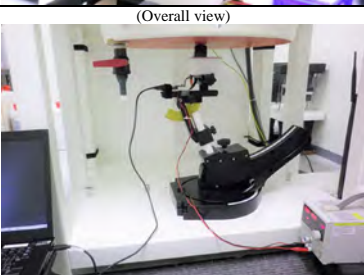

List of cables used

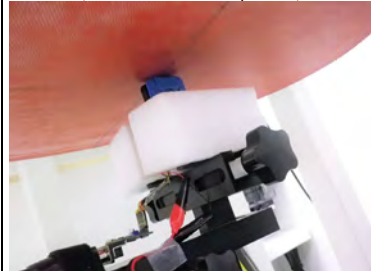
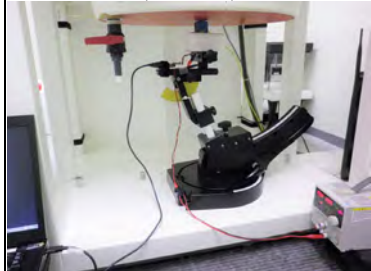
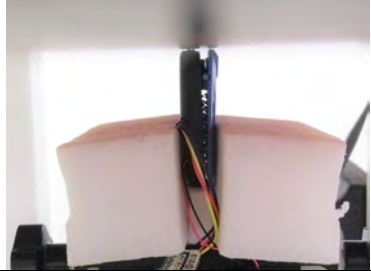
No.	Name	Length (m)	Shield	No.	Name	Length (m)	Shield
①	DC cable (with extension cable)	0.1+0.9 (extension)	Unshielded	②	IF cable	0.15	Unshielded

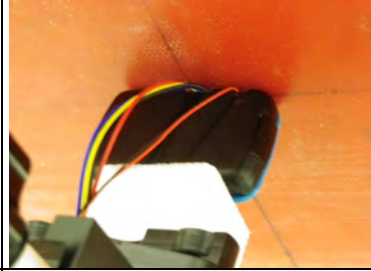
Appendix 1-3: Photograph of test setup

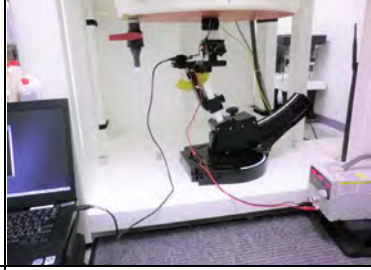
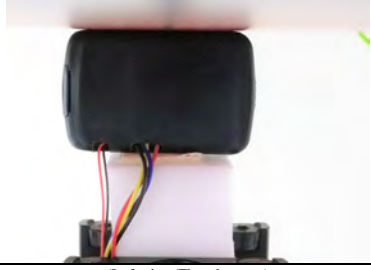
Position	Setup photographs		
Back (Clip) (Body-touch, D: 0mm) (Photo.P1)	(Front view/Flat-phantom) 	(Front view/Flat-phantom) 	(Front-bottom view/Flat-phantom) 
	(Left view/Flat-phantom) 	(Right view/Flat-phantom) 	(Overall view) 
	(Front view/Flat-phantom) 	(Front view/Flat-phantom) 	(Front-bottom view/Flat-phantom) 
	(Left view/Flat-phantom) 	(Right view/Flat-phantom) 	(Overall view) 
	(Front view/Flat-phantom) 	(Front-bottom view/Flat-phantom) 	(Rear view/Flat-phantom) 
	(Left view/Flat-phantom) 	(Right view/Flat-phantom) 	(Overall view) 
Top (USB) (Body-touch, D: 0mm) (Photo.P3)	(Left view/Flat-phantom) 	(Right view/Flat-phantom) 	(Overall view) 
	(Left view/Flat-phantom) 	(Right view/Flat-phantom) 	(Overall view) 

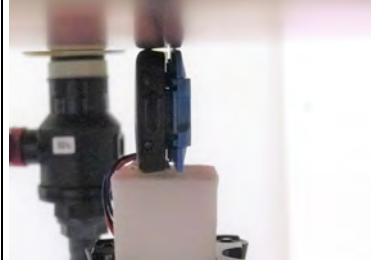
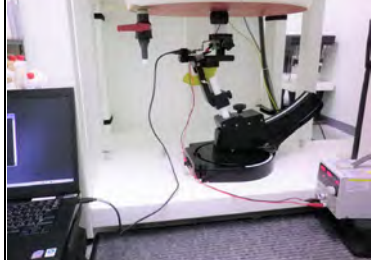
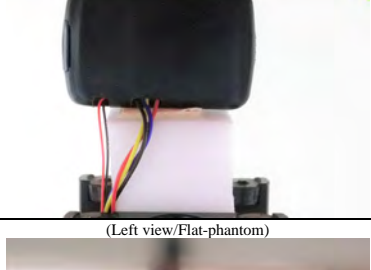
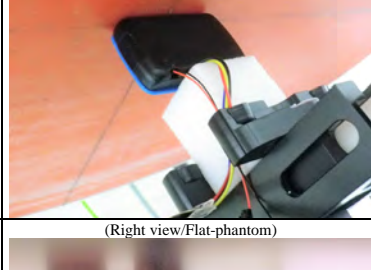
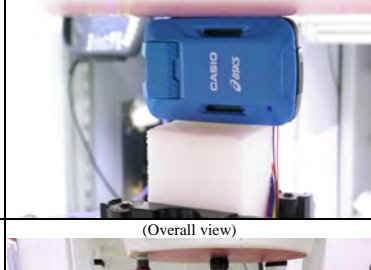
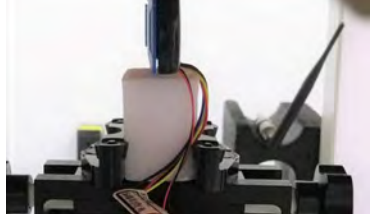
Appendix 1-3: Photograph of test setup (cont'd)

Position	Setup photographs		
Bottom (SW) (Body-touch, D: 0mm) (Photo.P4)	(Front view/Flat-phantom) 	(Front-bottom view/Flat-phantom) 	(Overall view) 
	(Left view/Flat-phantom) 	(Right view/Flat-phantom) 	(no photograph in here)
	(Front view/Flat-phantom) 	(Front-bottom view/Flat-phantom) 	(Rear view/Flat-phantom) 
Left (Body-touch, D: 0mm) (Photo.P5)	(Left view/Flat-phantom) 	(Right view/Flat-phantom) 	(Overall view) 
	(Front view/Flat-phantom) 	(Front-bottom view/Flat-phantom) 	(Rear view/Flat-phantom) 
	(Left view/Flat-phantom) 	(Right view/Flat-phantom) 	(Overall view) 
Right (Body-touch, D: 0mm) (Photo.P6)	(Front view/Flat-phantom) 	(Front-bottom view/Flat-phantom) 	(Rear view/Flat-phantom) 
	(Left view/Flat-phantom) 	(Right view/Flat-phantom) 	(Overall view) 