

TEST REPORT

Test Report No.: 10017FC

Applicant : Casio Computer Co., Ltd.
 EUT : Wireless LAN UNIT
 Model No. : WYCAAVDX2
 Serial No. : 2 (Radiated Emission Test and Conducted Emission Test)
 1 (Conducted RF Test via Antenna Terminal)
 FCC ID : BBQAF10
 Issue Date : 5 July 2010
 Date of Test : 14-16 June 2010 (Radiated Emission Test)
 28 May 2010 (Conducted RF Test via Antenna Terminal)
 Standard : FCC Part 15 Subpart C
 ANSI C63.4: 2003
 PUBLIC NOTICE DA 00-1407
 KDB doc. No. 558074 Measurement of Digital Transmission
 System Operating under § 15.247 (23 March 2005)
 Test Results : Pass

Approved By:

 Manager / Jiro Ogiwara

Reviewed By:

 / Yukihito Minegishi

 / Kentaro Fukuda

Tested By:

 / Yukihito Minegishi

 / Masashi Tsukui



NVLAP LAB CODE 200607-0

Table of Contents

Revised Record	3
1 Notice.....	4
1.1 General Information	4
1.2 Test Report	4
1.3 Test Condition	4
2 Applicant Information	5
2.1 Customer Information.....	5
2.2 Product Description	5
2.3 Summary of Test and Inspection Result.....	6
3 System Test Configuration	7
3.1 Justification	7
3.2 Operating Modes	8
3.3 Configuration of Tested System.....	9
3.4 Test Instruments	11
4 Antenna Requirement.....	12
5 AC Powerline Conducted Emission.....	13
5.1 Test Setup	13
5.2 Conducted Emission Calculation.....	14
5.3 Test Results	15
6 6dB Bandwidth	16
6.1 Test Setup	16
6.2 Test Results	16
7 Maximum Peak Output Power	18
7.1 Test Setup	18
7.2 Test Results	18
8 Band Edge Compliance.....	19
8.1 Test Setup	19
8.2 Test Results	19
9 Spurious RF Conducted Emission	21
9.1 Test Setup	21
9.2 Test Results	21
10 Radiated Emission.....	28
10.1 Test Setup	28
10.2 Radiated Emission Calculation.....	28
10.3 Test Results	29
11 Peak Power Spectral Density.....	47
11.1 Test Setup	47
11.2 Test Results	47
12 Photos of Tested EUT and Test Setup	49
Appendix 1: Certificate of Accreditation	50
Appendix 2: Test Instruments.....	51

Revised Record

Revised Record					
Number of Revised Time	Mark	Issue Date	Person in Charge	Detail of Revision	Approved By
Initial	-	5 July 2010	Masashi Tsukui	-	Jiro Ogiwara

1 Notice

1.1 General Information

TAIYO YUDEN CO., LTD. EMC Center.
5607-2, Nakamuroda-machi, Takasaki-shi, Gunma, 370-3347, Japan.

1. This laboratory is accredited as an ISO/IEC 17025:2005 testing facility by NVLAP. (NVLAP LAB CODE: 200607-0). Refer the certificate of the accreditation to Appendix 1.
2. This laboratory is listed by the Federal Communications Commission, Equipment Authorization Division (Registration Number: 606514) and listed by Industry Canada (No.4389A-1).
3. We hereby certify that no party to the applications authorized hereunder is subject to a denial of benefits, including FCC benefits, pursuant to Section 5301 of the Anti-Drug Abuse Act of 1988, 21 U.S.C 853(a).

1.2 Test Report

1. This report must not be used by the client to claim product certification, approval or endorsement by NVLAP, NIST or any agency of the Federal Government.
2. The test results in this report relate only to the tested samples.
3. This report shall not be reproduced except in full, without the written approval of the TAIYO YUDEN CO., LTD. EMC Center.
4. The test results in this report are traceable to international standards.
5. The tests described in this report were conducted only within the accredited scope.

1.3 Test Condition

1. FCC 47CFR, Part 15 Subpart C regulation tests were performed in the shielded room the 10m semi-anechoic chamber located at TAIYO YUDEN CO., LTD. EMC Center, 5607-2 Nakamuroda-machi, Takaski-shi, Gunma, 370-3347 Japan.
2. The EUT was not modified for the tests described in this report.
3. The tests described in this report were conducted according to the methods in the test specification.
4. Special accessories or peripheral equipments specific to the EUT were not used for the tests described in this report.

2 Applicant Information

2.1 Customer Information

Company Name	Casio Computer Co., Ltd.
Address	2-1, Sakae-cho 3-chome, Hamura-shi, Tokyo 205-8555, Japan

2.2 Product Description

EUT	Wireless LAN UNIT
Model No.	WYCAAVDX2
Serial No.	2 (Radiated Emission Test and Conducted Emission Test) 1 (Conducted RF Test via Antenna Terminal)
FCC ID	BBQAF10
Production Stage	Prototype
Type of Wide Band Modulation	IEEE 802.11b: DSSS, IEEE 802.11g: OFDM
Type of Modulation	DBPSK (1Mbps), DQPSK (2Mbps) and CCK (5.5/11Mbps) for 11b BPSK (6/9Mbps), QPSK (12/18Mbps), 16QAM (24/36Mbps) and 64QAM (48/54Mbps) for 11g
ITU Code	D1D, G1D
Power Supply	DC 5.00V
Operating Voltage Range	DC 3.40V Min. DC 5.50V Max.
Operating Temperature Range	0 degree C Min. 80 degree C Max.
Dimensions of EUT	W 45.0mm * L 14.5mm * H 3.0mm
Antenna Type	Mono-Pole
Max Antenna Gain	1.90dBi
Operating Clocks	38.4MHz
Receipt Date of Tested Sample	17 May 2010

This EUT is Wireless LAN UNIT.
EUT operates in the unlicensed 2.4GHz ISM (Industrial Scientific Medical) band.

2.3 Summary of Test and Inspection Result

No.	Item	Test Procedure	Specification	Remarks	Tested	Worst Margin	Results
1	AC Powerline Conducted Emission	ANSI C63.4: 2003 *1	FCC 15.207	Conducted Emission Test	Performed	Quasi Peak: 16.3dB Average: 12.0dB Frequency: 15.510MHz Transmitting Mode: 2462MHz Type of Modulation: IEEE 802.11g (6Mbps) Line Phase: L1	Pass
2	6dB Bandwidth		FCC 15.247(a)(2)	Conducted RF Test via Antenna Terminal	Performed	-	Pass
3	Maximum Peak Output Power		FCC 15.247(b)(3)		Performed	-	Pass
4	Band Edge Compliance		FCC 15.247(d)		Performed	-	Pass
5	Spurious RF Conducted Emission		FCC 15.247(d)		Performed	-	Pass
6	Radiated Emission		FCC 15.247(d)	Radiated Emission Test	Performed	Peak: 18.1dB Average: 8.6dB Frequency: 7386.000MHz Transmitting Mode: 2462MHz Type of Modulation: IEEE 802.11b (1Mbps) Axial Direction: XY-Plane Antenna Polarization: Vertical	Pass
7	Peak Power Spectral Density		FCC 15.247(e)	Conducted RF Test via Antenna Terminal	Performed	-	Pass

*1: These tests were also referred to KDB doc. No. 558074 "Measurement of Digital Transmission Systems Operating under Section 15.247" (23 March 2005).

3 System Test Configuration

3.1 Justification

1. Emission tests were performed with no deviation from the ANSI C63.4: 2003 and FCC 47CFR, Part 15, Section 15.247 regulation tests were performed with no deviation from the FCC Public Notice DA00-1407 released June 26, 2000.
2. The system was configured for testing a typical fashion (as a customer would normally use it.).
3. Radiate testing in the range of 1GHz to 25GHz was investigated with the spectrum (peak detector function) under the FCC regulation section 15.209 (e) and 15.35 (b). Radiate testing in the range of 18GHz to 25GHz performed at an antenna to EUT distance of 1m. The level of any unwanted emissions from EUT did not exceed the level of the fundamental emission (Compliance with 15.209 (c)). And test result found to be compliance with FCC regulation section 15.209 (a) Radiated emission limits (500uV/m). Data is presented for the “worst case” measurements, that EUT was normal operated.
4. Radiate testing in the range of 30MHz to 1000MHz was performed at an antenna to EUT distance of 3m under the 15.209 (e) and 15.31(f)(1).
5. Tests were performed with the representative channel operation as follows.
 - a. Lowest Frequency channel: 1ch 2412MHz
 - b. Middle Frequency channel: 6ch 2437MHz
 - c. Highest Frequency channel: 11ch 2462MHz

3.2 Operating Modes

Transmitting Mode

Type of Modulation	IEEE 802.11b: DBPSK (1Mbps)
	IEEE 802.11g: BPSK (6Mbps)
Representative Channel	1ch 2412MHz (Lowest Frequency Channel)
	6ch 2437MHz (Middle Frequency Channel)
	11ch 2462MHz (Highest Frequency Channel)

Remarks:

Software (Controller): MFG-SD-8686-WIN-X86-GEN Ver.1.4.1 software supplied by Marvell was used to set up to the wireless LAN operating mode.

3.3 Configuration of Tested System

(1) Conducted Emission Test

These numbers and the marks in the picture are corresponding to the numbers and the marks in tables shown.
 Power Supply of EUT: DC 5.00V from Supporting Equipment “b”.
 (Power supply to Supporting Equipment “b” was supplied by Note PC “c”)

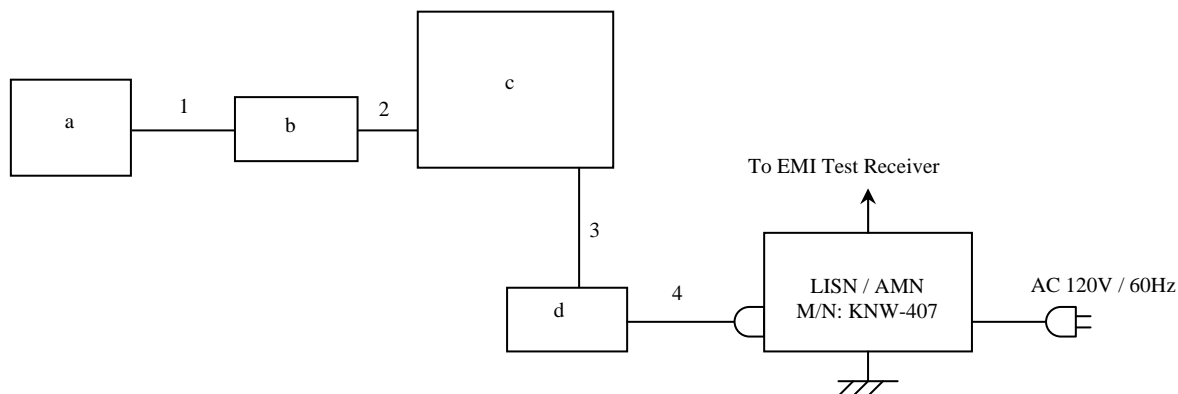

List of EUT and Accessories

	Product Name	Model No.	Serial No.	Manufacturer	EUT / Accessory	FCC ID / DoC
a	Wireless LAN UNIT	WYCAAVDX2	2	TAIYO YUDEN	EUT	BBQAF10
b	Supporting Equipment	-	5	TAIYO YUDEN	Accessory	-
c	Note PC	Pavilion dv900	7	HP	Accessory	-
d	AC Adapter for Note PC	PPP012L-S	7509178 901	HP	Accessory	-

Interface Cables

	Cable Type	Model No.	Shielded	Ferrite Core	Length	Treatment for the Extra Length
1	Bus Cable	-	No	No	0.27m	-
2	DC Cable	-	No	No	0.10m	-
3	DC Cable	-	No	Yes	1.85m	Fold back and forth in the center
4	AC Cable	-	No	No	1.80m	Fold back and forth in the center

(2) Conducted RF Test via Antenna Terminal

These numbers and the marks in the picture are corresponding to the numbers and the marks in tables shown.
 Power Supply of EUT: DC 5.00V from Supporting Equipment “b”.
 (Power supply to the Supporting Equipment “b” was supplied by Regulated DC Power Supply “c”)

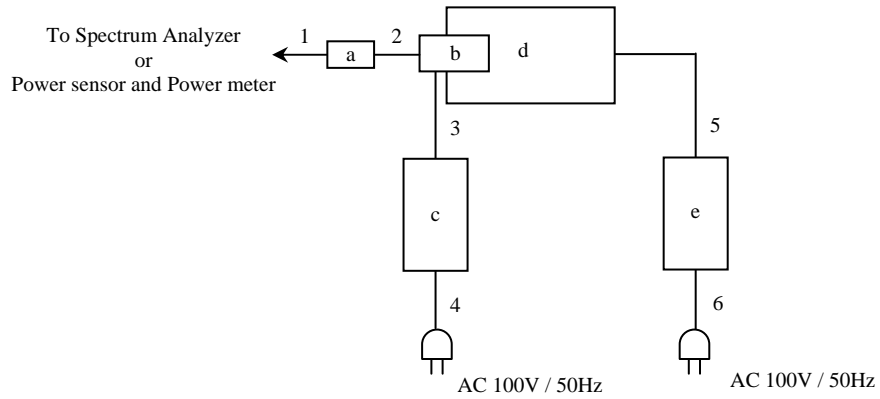

List of EUT and Accessories

	Product Name	Model No.	Serial No.	Manufacturer	EUT / Accessory	FCC ID / DoC
a	Wireless LAN UNIT	WYCAAVDX2	1	TAIYO YUDEN	EUT	BBQAF10
b	Supporting Equipment	-	5	TAIYO YUDEN	Accessory	-
c	Regulated DC Power Supply	PMC18-3A	LK000371	KIKUSUI	Accessory	-
d	Note PC	Pavilion dv900	7	HP	Accessory	-
e	AC Adapter for Note PC	PPP012L-S	7509178901	HP	Accessory	-

Interface Cables

	Cable Type	Model No.	Shielded	Ferrite Core	Length	Notes
1	RF Cable	-	No	No	0.10m	-
2	Bus Cable	-	No	No	0.27m	-
3	DC Cable	-	No	No	0.50m	-
4	AC Cable	-	No	No	1.80m	-
5	DC Cable	-	No	Yes	1.85m	-
6	AC Cable	-	No	No	1.80m	-

(3) Radiated Emission Test

These numbers and the marks in the picture are corresponding to the numbers and the marks in tables shown.
 Power Supply of EUT: DC 5.00V from Supporting Equipment “b”.
 (Power supply to the Supporting Equipment “b” was supplied by Regulated DC Power Supply “c”)

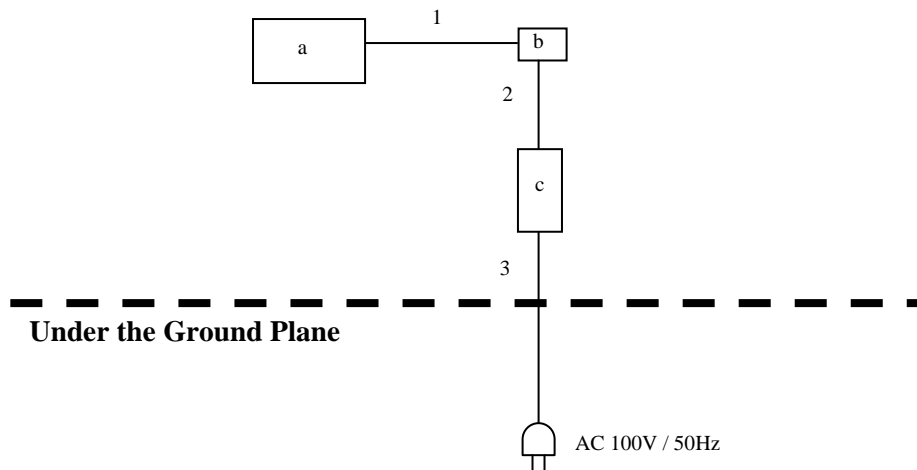

List of EUT and Accessories

	Product Name	Model No.	Serial No.	Manufacturer	EUT / Accessory	FCC ID / DoC
a	Wireless LAN UNIT	WYCAAVDX2	2	TAIYO YUDEN	EUT	BBQAF10
b	Supporting Equipment	-	5	TAIYO YUDEN	Accessory	-
c	Regulated DC Power Supply	PA18-1.2A	2110071	KENWOOD	Accessory	-

Interface Cables

	Cable Type	Model No.	Shielded	Ferrite Core	Length	Notes
1	Bus Cable	-	No	No	0.27m	-
2	DC Cable	-	No	No	0.50m	-
3	AC Cable	-	No	No	2.06m	-

3.4 Test Instruments

About test instruments for all tests, please refer to appendix 2.

4 Antenna Requirement

The EUT provides a permanently attached antenna and it was found to be compliant with FCC regulation section 15.203.

Antenna Type	Mono-Pole
Antenna Gain	1.90dBi

5 AC Powerline Conducted Emission

Pre-Scan has been conducted to determine the worst-case mode from all possible combinations between available modulations.

5.1 Test Setup

Conducted emission measurements were performed from 150kHz to 30MHz.

The test setup was made according to ANSI STD C63.4: 2003 clause 7 in the Shielded room.

The rear of non-conductive wooden table top was placed 0.4m from a vertical metal reference plane that one of the wall.

Rears of the peripherals were all aligned and flush with rear of non-conductive wooden tabletop.

The height of this table was 0.8m and 1.5m wide x 1.0m deep size.

The spacing between the each equipment was 10cm.

Connection of the PC connected EUT USB Adaptor to the Artificial Mains Network (AMN)/ Line Impedance Stabilization Network (LISN) was required.

The distance between the closet surface of the EUT and the closet surface of the AMN (LISN) was 0.8m.

Connection of the all other equipment to the second AMN (LISN) was required. The distance between the peripherals and the closet surface of the second AMN (LISN) was minimum 0.8m.

The second artificial mains network is terminated with 50 ohm terminator.

Where a mains flexible cord is provided by the manufacture this is 2.0m long and excess cable was folded back and forth as far as possible to 0.8m so as to form a bundle not exceeding 0.4 m in length.

Interconnecting cables of table top equipment that hang closer than 0.4m to the floor ground plane were folded back and forth forming a bundle 30 to 40cm long, hanging approximately in the middle between ground plane and table.

The measurement has been conducted with both L1 (Neutral) and L2 (Line) power supply polarization.

The maximum voltage emission was verified with the cable routing and the location of the peripherals.

The highest voltage emission has been recorded.

For further description of the configuration refer to separate document named "Test Setup Photos (10017FC)".

Test Receiver Setting:

150kHz~30MHz:

Detector Mode	Quasi-Peak and Average
Bandwidth	10kHz

5.2 Conducted Emission Calculation

The basic equation with a sample calculation is as follows:

$$\begin{aligned} \text{c.f.} &= \text{CF} + \text{AL} \\ \text{CE} &= \text{RA} + \text{c.f.} \end{aligned}$$

Where	c.f.	:	Correction Factor [dB]
	CE	:	Conducted Emission (Emission Level - Result) [dBuV]
	RA	:	Receiver Amplitude (Reading Level) [dBuV]
	CF	:	Cable Attenuation Loss [dB]
	AL	:	Attenuator Loss [dB]

Assume a receiver reading of 40.8dBuV is obtained.

The Factor of 3.4dB is added, giving a terminal voltage of 44.2dBuV. The 44.2dBuV value was mathematically converted to its corresponding level in uV.

$$\text{CE} = 40.8 + 3.4 = 44.2\text{dBuV}$$

$$\text{Level in uV} = \text{Common Antilogarithm: } 10^{(44.2 / 20)} = 162.2\text{uV}$$

5.3 Test Results

Product	: Wireless LAN UNIT	Model	: WCAAVDX2
Serial No.	: 2	Test Standard	: FCC Part15 Subpart C §15.207
Power Supply	: DC 5.00V	Temp. / Humid.	: 23.4 degree C / 67.0%
Operator	: Masashi Tsukui		
Remark	: Transmitting Mode IEEE 802.11g (6Mbps)		

AC Powerline Conducted Emission: Lch (2412MHz)

Frequency [MHz]	Line Phase	Reading [dB(uV)]		Factor [dB]	Level [dB(uV)]		Limit [dB(uV)]		Margin [dB]		Remark
		QP / AV	QP / AV		QP / AV	QP / AV	QP / AV	QP / AV			
0.15833	L1	45.3	26.9	3.7	49.0	30.6	65.6	55.6	16.6	25.0	
0.2901	L1	40.0	27.0	3.4	43.4	30.4	60.5	50.5	17.1	20.1	
15.52452	L1	39.1	33.5	4.1	43.2	37.6	60.0	50.0	16.8	12.4	
0.15803	L2	49.7	31.1	3.7	53.4	34.8	65.6	55.6	12.2	20.8	
0.28933	L2	41.1	27.6	3.4	44.5	31.0	60.5	50.5	16.0	19.5	
15.2408	L2	37.5	31.6	3.9	41.4	35.5	60.0	50.0	18.6	14.5	

AC Powerline Conducted Emission: Mch (2437MHz)

Frequency [MHz]	Line Phase	Reading [dB(uV)]		Factor [dB]	Level [dB(uV)]		Limit [dB(uV)]		Margin [dB]		Remark
		QP / AV	QP / AV		QP / AV	QP / AV	QP / AV	QP / AV			
0.15819	L1	49.3	31.0	3.7	53.0	34.7	65.6	55.6	12.6	20.9	
0.28848	L1	40.5	27.0	3.4	43.9	30.4	60.6	50.6	16.7	20.2	
15.230	L1	38.3	31.8	4.1	42.4	35.9	60.0	50.0	17.6	14.1	
0.15696	L2	49.6	32.2	3.7	53.3	35.9	65.6	55.6	12.3	19.7	
0.28812	L2	41.1	27.6	3.4	44.5	31.0	60.6	50.6	16.1	19.6	
15.30891	L2	37.6	31.8	3.9	41.5	35.7	60.0	50.0	18.5	14.3	

AC Powerline Conducted Emission: Hch (2462MHz)

Frequency [MHz]	Line Phase	Reading [dB(uV)]		Factor [dB]	Level [dB(uV)]		Limit [dB(uV)]		Margin [dB]		Remark
		QP / AV	QP / AV		QP / AV	QP / AV	QP / AV	QP / AV			
0.15735	L1	49.8	31.6	3.7	53.5	35.3	65.6	55.6	12.1	20.3	
0.289	L1	40.4	27.1	3.4	43.8	30.5	60.6	50.6	16.8	20.1	
15.510	L1	39.6	33.9	4.1	43.7	38.0	60.0	50.0	16.3	12.0	
0.15814	L2	49.7	13.3	3.7	53.4	17.0	65.6	55.6	12.2	38.6	
0.28902	L2	41.4	27.6	3.4	44.8	31.0	60.6	50.6	15.8	19.6	
15.40381	L2	38.1	32.6	3.9	42.0	36.5	60.0	50.0	18.0	13.5	

6 6dB Bandwidth

6.1 Test Setup

The spectrum analyzer was connected to the transmitter output port through the RF cable.

Spectrum Analyzer Setting:

Detector Mode	Peak
RBW	100kHz
VBW	300kHz
Span	20MHz
Sweep Time	Auto

6.2 Test Results

Serial No. : 1
 Power : DC 5.00V
 Mode : Transmitting Mode (1ch, 6ch, 11ch)
 IEEE 802.11b: DBPSK (1Mbps)
 IEEE 802.11g: BPSK (6Mbps)
 Temperature : 23.3 degree C
 Humidity : 60.0 %
 Regulation : FCC Part15 C §15.247 (a)(2)

Channel	Frequency [MHz]	6dB Bandwidth [MHz]	Limit [MHz]
IEEE 802.11b: DBPSK (1Mbps)			
1ch (Lowest)	2412	10.18	>=0.5
6ch (Middle)	2437	10.18	>=0.5
11ch (Highest)	2462	10.16	>=0.5
IEEE 802.11g: BPSK (6Mbps)			
1ch (Lowest)	2412	16.47	>=0.5
6ch (Middle)	2437	16.47	>=0.5
11ch (Highest)	2462	16.47	>=0.5

The spectrum data are attached next page. Display line indicates the 6dB offset below highest level. It shows compliance with the requirement in part 15.247(a)(2).

Data of 6dB Bandwidth

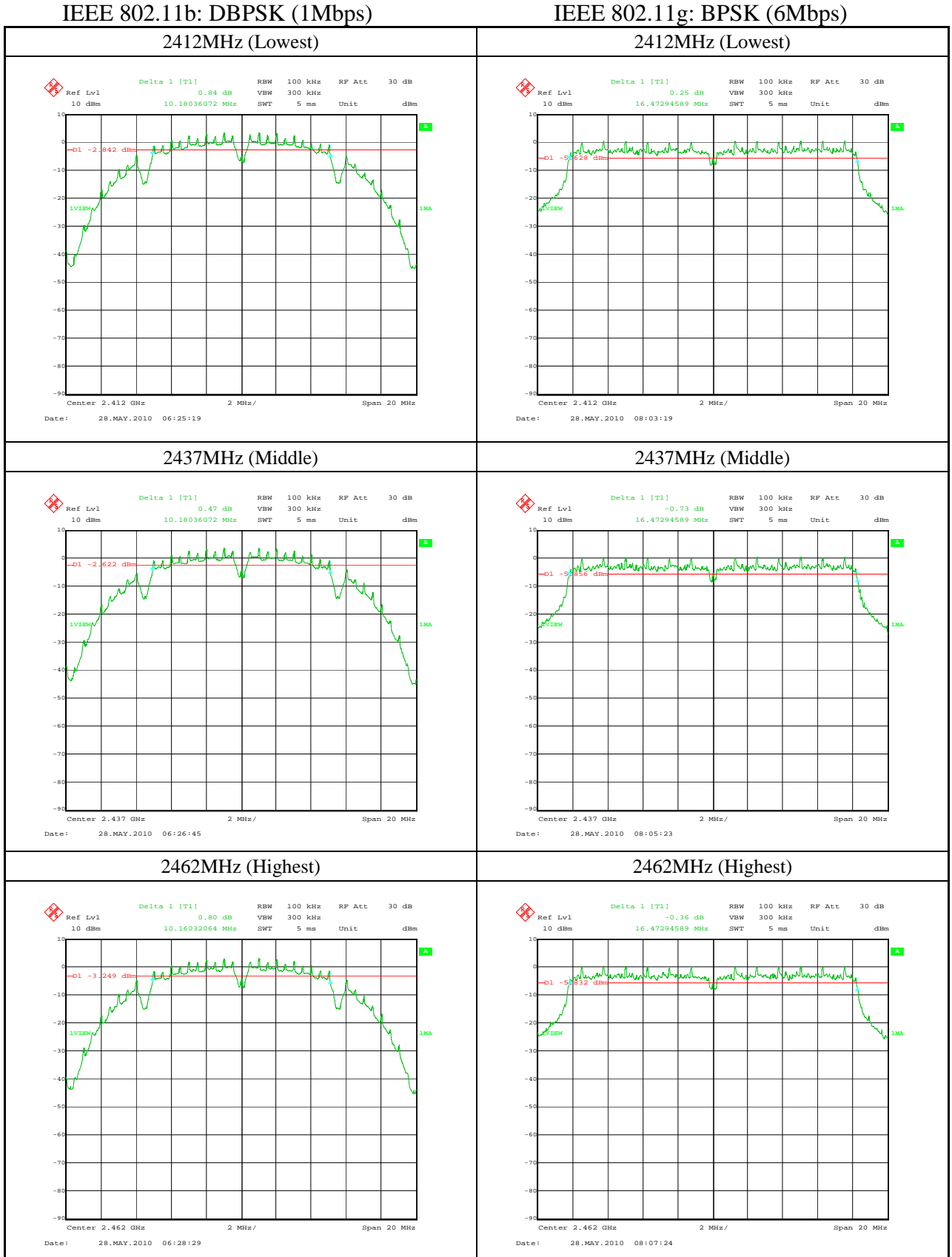

7 Maximum Peak Output Power

7.1 Test Setup

The peak power meter was connected to the transmitter output port through the RF cable.

7.2 Test Results

Serial No. : 1
 Power : DC 5.00V
 Mode : Transmitting Mode (1ch, 6ch, 11ch)
 IEEE 802.11b: DBPSK (1Mbps)
 IEEE 802.11g: BPSK (6Mbps)
 Temperature : 23.3 degree C
 Humidity : 60.0 %
 Regulation : FCC Part15 C §15.247 (b)(3)

Channel	Frequency [MHz]	Reading [dBm]	Cable Loss1 [dB]	Cable Loss2 [dB]	Result		Limit	
					[dBm]	[mW]	[dBm]	[mW]
IEEE 802.11b: DBPSK (1Mbps)								
1ch (Lowest)	2412	15.27	0.67	0.50	16.44	44.06	< 30.0	< 1000
6ch (Middle)	2437	15.25	0.67	0.50	16.42	43.85	< 30.0	< 1000
11ch (Highest)	2462	15.08	0.68	0.50	16.26	42.27	< 30.0	< 1000
IEEE 802.11g: BPSK (6Mbps)								
1ch (Lowest)	2412	22.21	0.67	0.50	23.38	217.77	< 30.0	< 1000
6ch (Middle)	2437	22.14	0.67	0.50	23.31	214.29	< 30.0	< 1000
11ch (Highest)	2462	21.97	0.68	0.50	23.15	206.54	< 30.0	< 1000

Result = Reading + Cable Loss1 + Cable Loss2

Note: Cable Loss1: RF Cable

Cable Loss2: Conversion cable used for connecting to SMA type

8 Band Edge Compliance

8.1 Test Setup

The spectrum analyzer was connected to the transmitter output port through the RF cable.

Spectrum Analyzer Setting:

Detector Mode	Peak
RBW	100kHz
VBW	300kHz
Span	150MHz
Sweep Time	Auto

8.2 Test Results

Serial No.	:	1
Power	:	DC 5.00V
Mode	:	Transmitting Mode (1ch, 6ch, 11ch) IEEE 802.11b: DBPSK (1Mbps) IEEE 802.11g: BPSK (6Mbps)
Temperature	:	23.3 degree C
Humidity	:	60.0 %
Regulation	:	FCC Part15 C §15.247 (d)

The spectrum data are attached next page. Display line indicates the 20dB offset below highest level. It shows compliance with the requirement in part 15.247(d).

Data of Band Edge Compliance

(1) IEEE 802.11b: DBPSK (1Mbps)

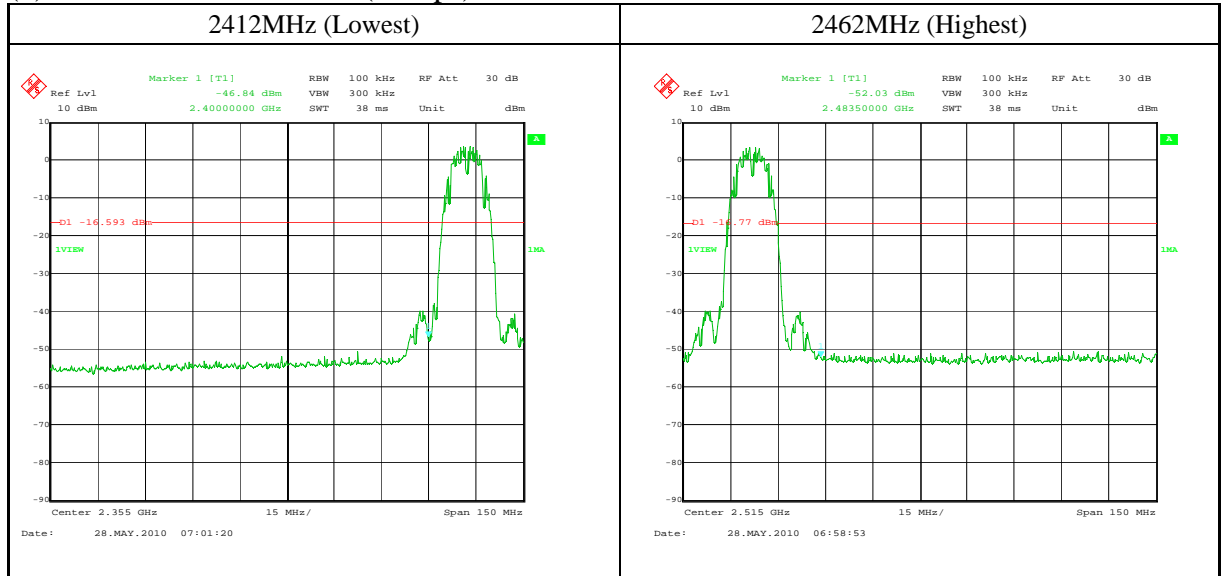

(2) IEEE 802.11g: BPSK (6Mbps)

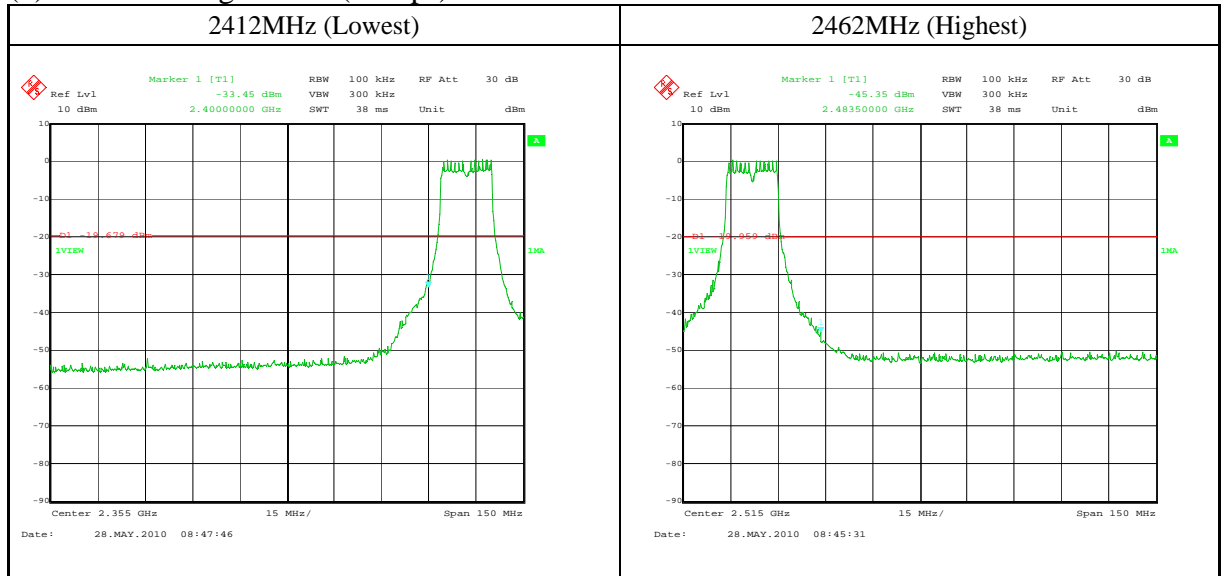

9 Spurious RF Conducted Emission

9.1 Test Setup

The spectrum analyzer was connected to the transmitter output port through the RF cable.

Spectrum Analyzer Setting:

Detector Mode	Peak
RBW	100kHz
VBW	300kHz
Sweep Time	Auto

9.2 Test Results

Serial No. : 1
Power : DC 5.00V
Mode : Transmitting Mode (1ch, 6ch, 11ch)
IEEE 802.11b: DBPSK (1Mbps)
IEEE 802.11g: BPSK (6Mbps)
Temperature : 23.3 degree C
Humidity : 60.0 %
Regulation : FCC Part15 C §15.247 (d)

The spectrum data are attached next page. Display line indicates the 20dB offset below highest level.
It shows compliance with the requirement in part 15.247(d).

Data of Spurious Conducted Emission

(1) IEEE 802.11b: DBPSK (1Mbps): 2412MHz

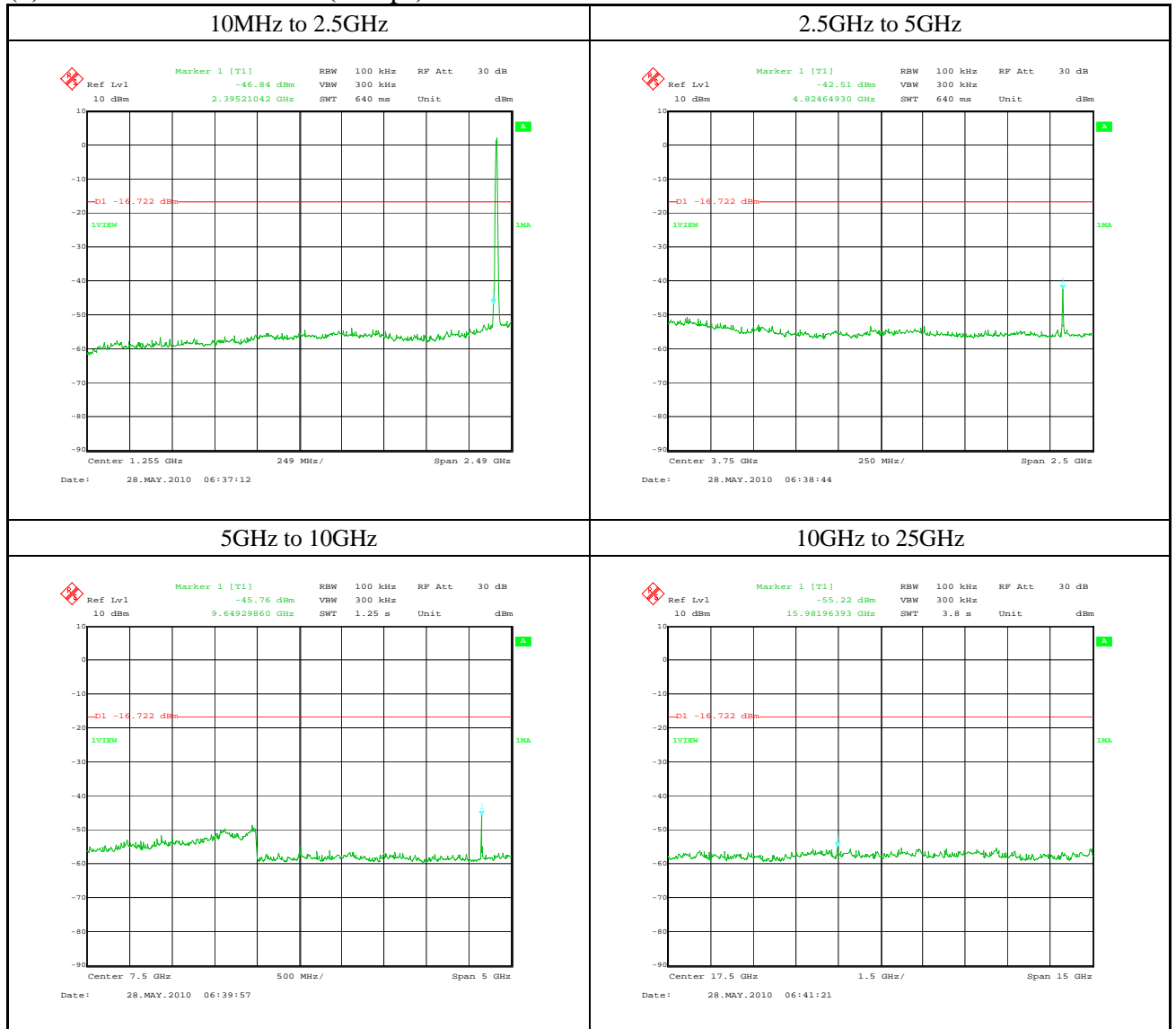

(2) IEEE 802.11b: DBPSK (1Mbps): 2437MHz

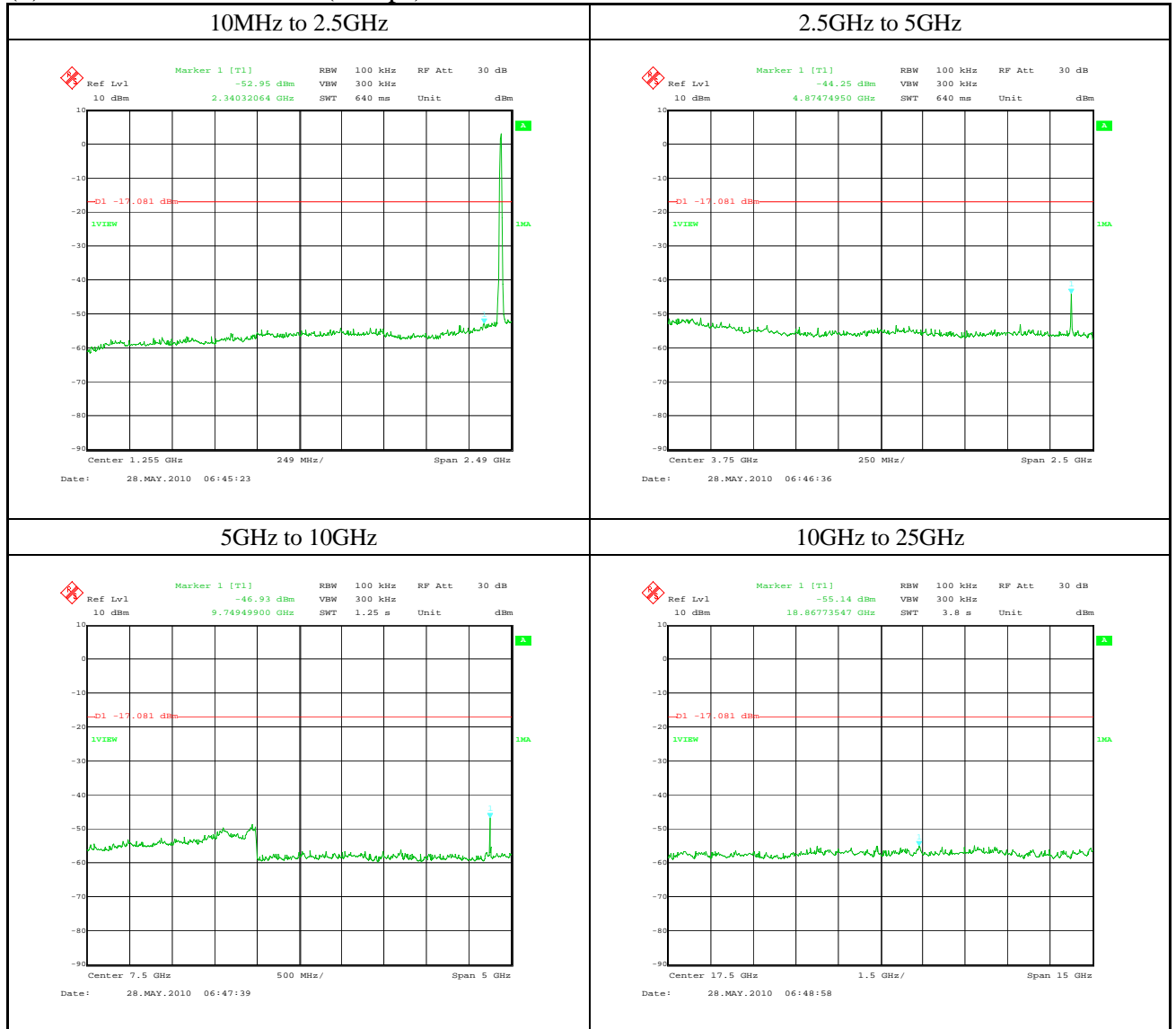

(3) IEEE 802.11b: DBPSK (1Mbps): 2462MHz

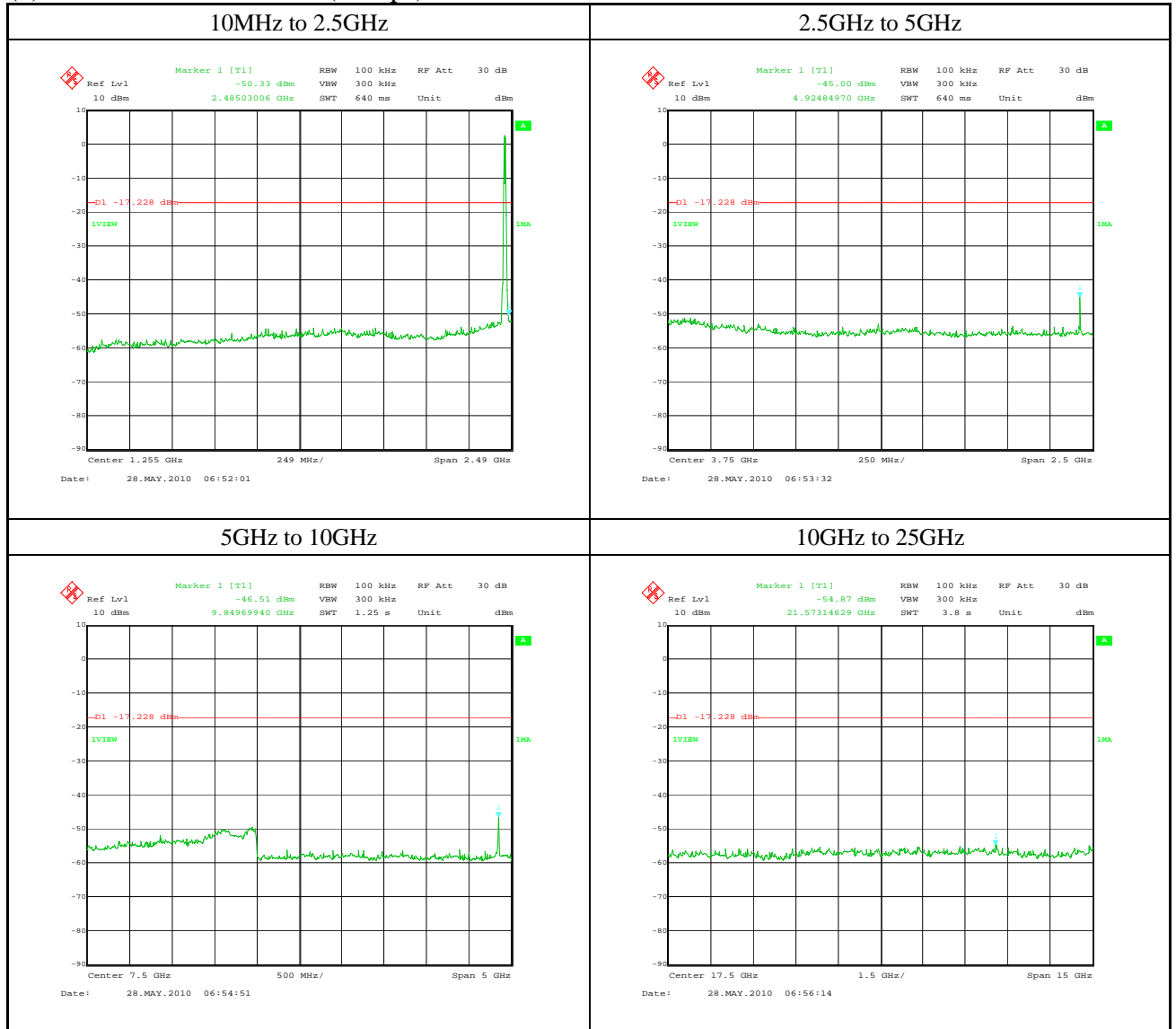

(4) IEEE 802.11g: BPSK (6Mbps): 2412MHz

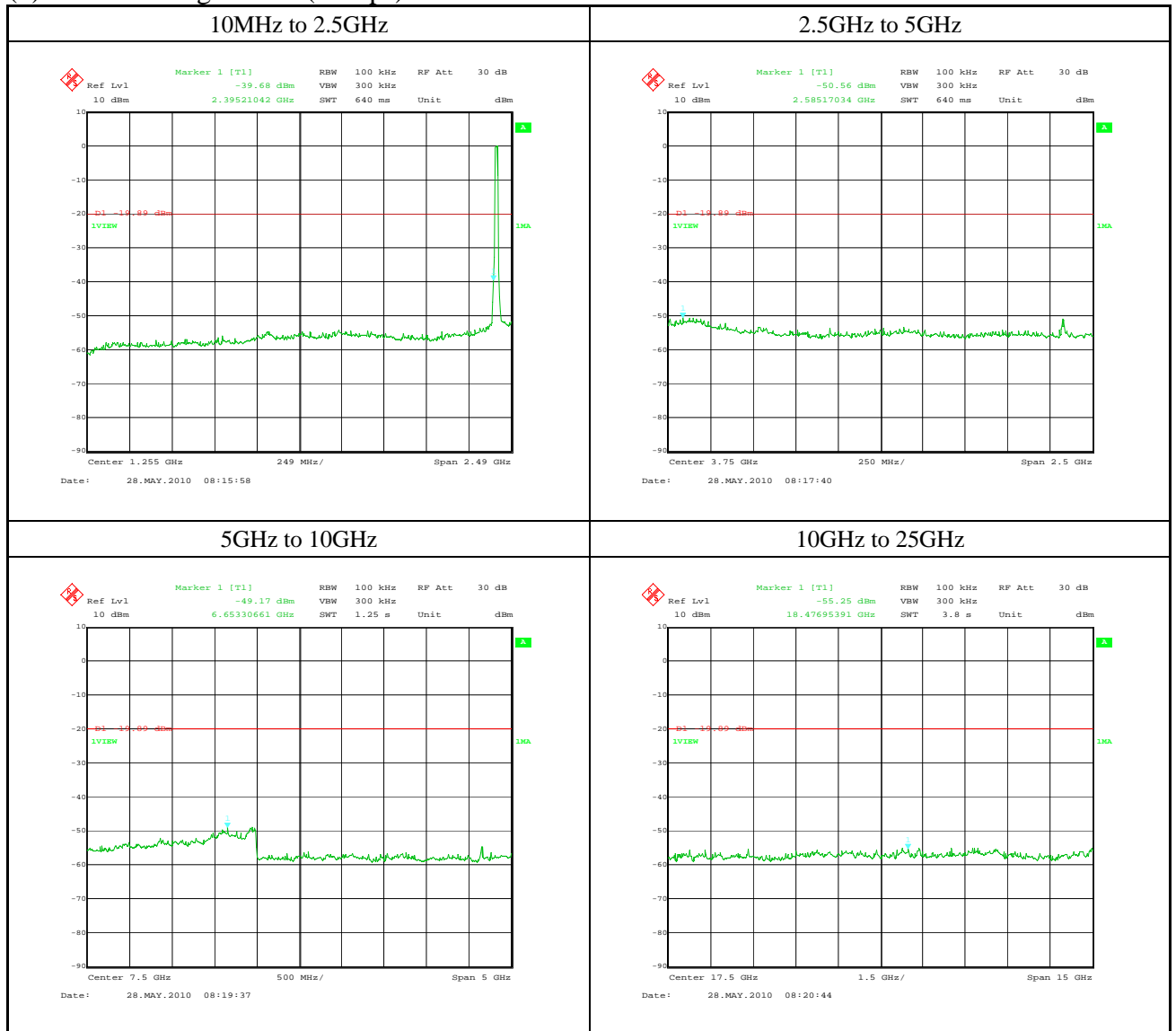

(5) IEEE 802.11g: BPSK (6Mbps): 2437MHz

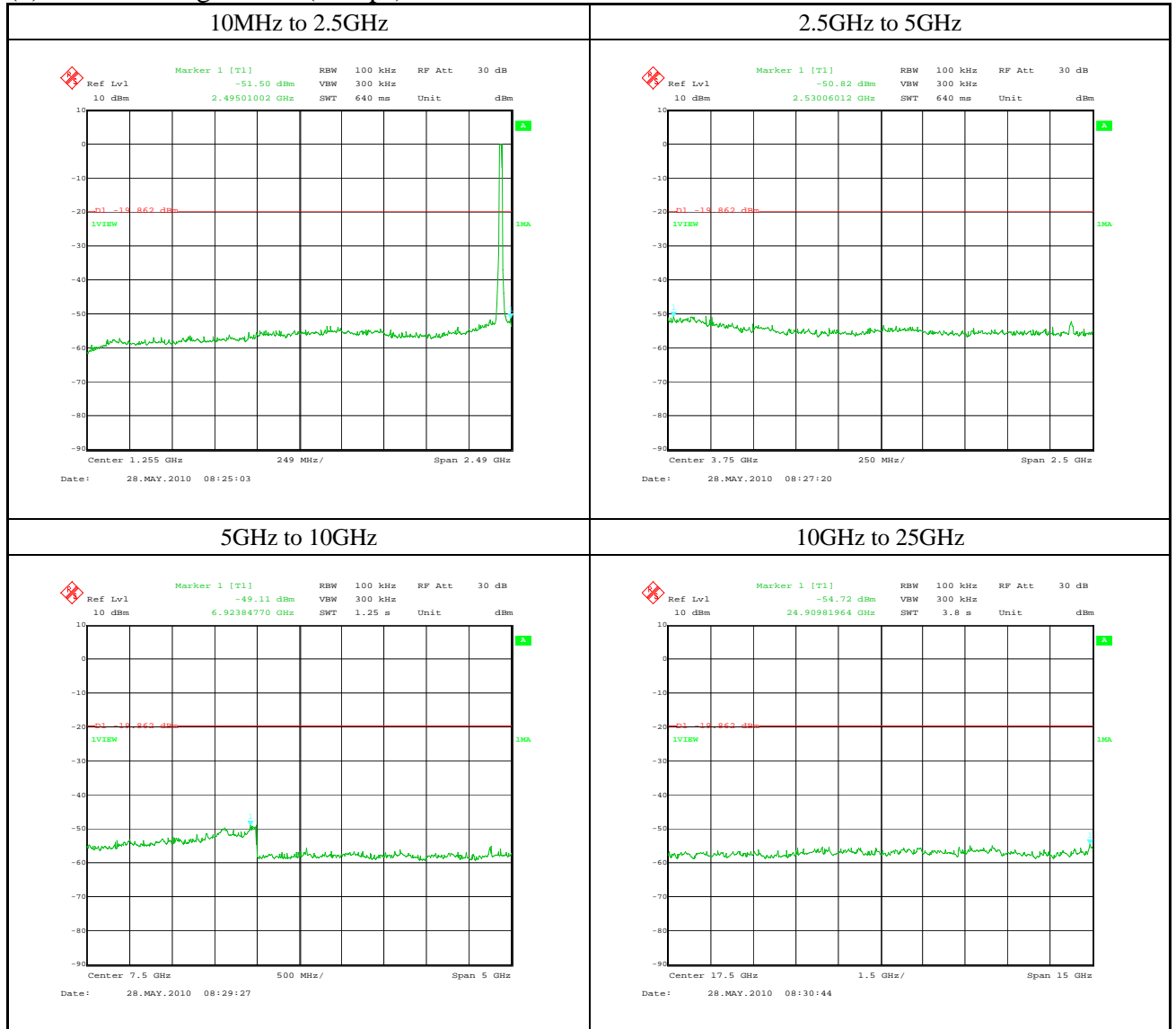

(6) IEEE 802.11g: BPSK (6Mbps): 2462MHz

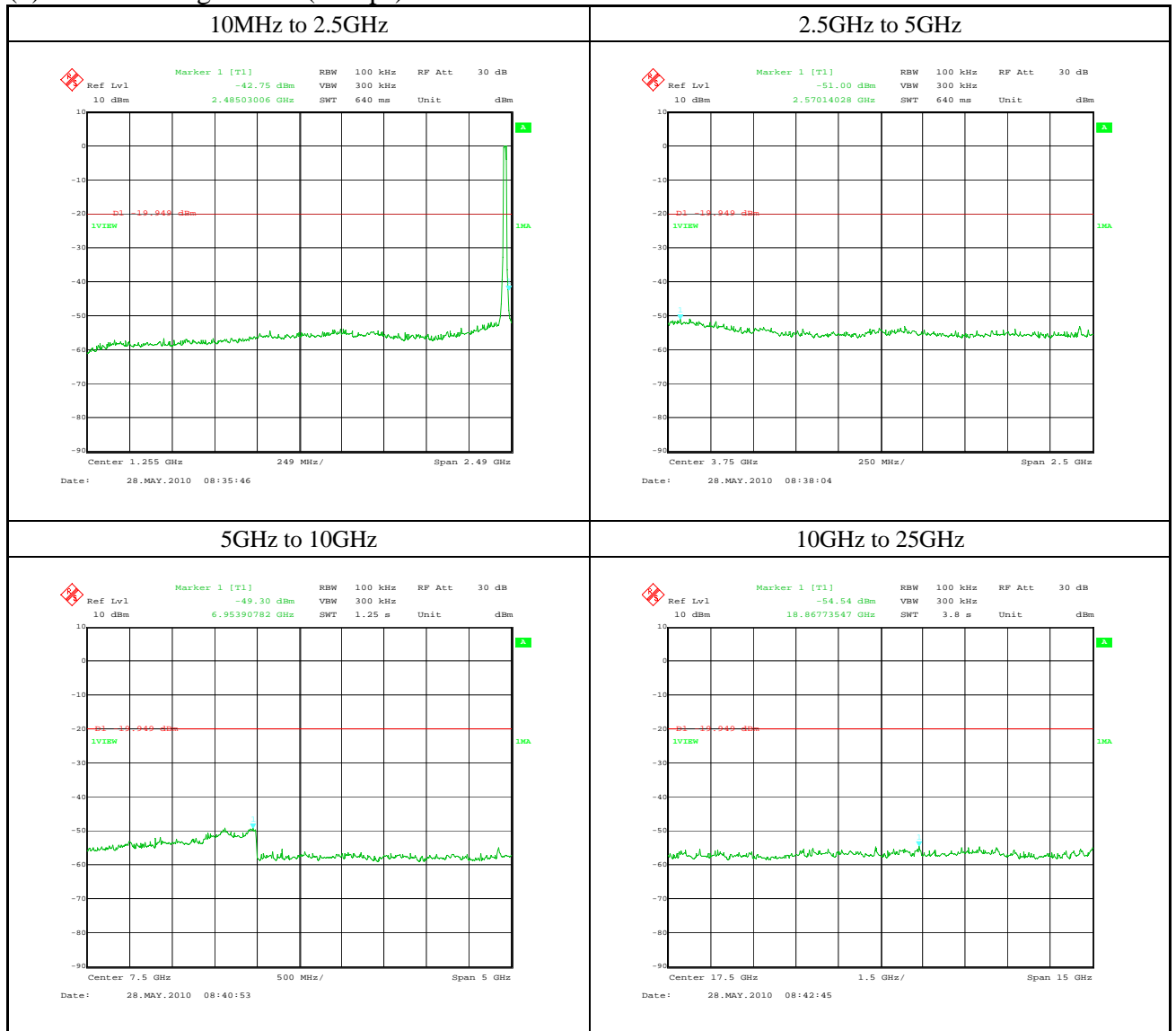

10 Radiated Emission

10.1 Test Setup

The test setup was made according to ANSI STD C63.4: 2003 clause 8 on the 10m semi-anechoic chamber, which allows a 3 or 1m distance measurement.

EUT was placed on non-conductive table (foam polystyrene).

The height of this table was 0.8m.

The measurement has been conducted with both horizontal and vertical antenna polarization.

For above 1GHz, the receiving antenna is fixed in the height that EUT is in the illumination area of the 3dB beamwidth of the antenna.

The turntable has been fully rotated. The highest radiation of the equipment has been recorded.

For further description of the configuration refer to separate document named "Test Setup Photos (10017FC)".

Distance between equipment and antenna : 3m (30MHz to 18GHz)
1m (18GHz to 25GHz)

Test Receiver Setting:

30~1000MHz:

Detector Mode	Quasi-Peak
Bandwidth	120kHz

Spectrum Analyzer Setting:

1~25GHz:

Detector Mode	Peak and Average
Bandwidth	Peak: RBW: 1MHz, VBW: 1MHz
	Average: RBW: 1MHz, VBW: 10Hz

10.2 Radiated Emission Calculation

The field strength is calculated by adding the Antenna Factor and Cable Loss, and subtracting the Amplifier Gain (if any) from the measured reading.

The basic equation with a sample calculation is as follows:

$$\begin{aligned} \text{c.f.} &= \text{AF} + \text{CF} + \text{AL} - \text{AG} - \text{DF} \\ \text{RE} &= \text{RA} + \text{c.f.} \end{aligned}$$

Where

c.f.	:	Correction Factor [dB (1/m)]
RE	:	Radiated Emission (Emission Level - Result) [dB (uV/m)]
RA	:	Receiver Amplitude (Reading Level) [dBuV]
AF	:	Antenna Factor [dB (1/m)]
CF	:	Cable Attenuation Loss [dB]
AG	:	Amplifier Gain [dB]
AL	:	Attenuator Loss [dB]
DF	:	Distance Factor
		Distance between equipment and antenna: 3m = 0 [dB]
		Distance between equipment and antenna: 1m = 9.5 [dB]

Assume a receiver reading of 36.5dBuV is obtained.

The Correction Factor of -2.0dB/m is added, giving a Radiated Emission of 34.5dBuV/m.

The 34.5dBuV/m value was mathematically converted to its corresponding level in uV/m.

$$\begin{aligned} \text{RE} &= 36.5 + (-2.0) = 34.5\text{dBuV/m} \\ \text{Level in uV/m} &= \text{Common Antilogarithm: } 10^{(34.5 / 20)} = 53.1\text{uV/m} \end{aligned}$$

10.3 Test Results

Product	: <u>Wireless LAN UNIT</u>	Model	: <u>WCAAVDX2</u>
Serial No.	: <u>2</u>	Test Standard	: <u>FCC Part15 Subpart C §15.247(d)</u>
Power Supply	: <u>DC 5.00V</u>		
Operator	: <u>Masashi Tsukui</u>		
Remark	: <u>Transmitting Mode</u> <u>IEEE 802.11b (1Mbps)</u>		

Radiated Emission: Lch (2412MHz)

Temp. / Humid.: Below 1GHz 21.4 degree C / 71.5%
 1-6GHz 22.5 degree C / 65.6%
 Above 6GHz 21.9 degree C / 64.7%

Axial Direction: XY-Plane

Below 1GHz

Frequency [MHz]	Pol. [H / V]	Reading [dB(uV)] QP / AV / PK			Factor [dB/m]	Level [dB(uV/m)] QP / AV / PK			Limit [dB(uV/m)]	Margin [dB] QP / AV / PK			Remark
250.000	H	20.5			-9.1	11.4			46.0	34.6			Floor Noise
500.000	H	21.2			-2.7	18.5			46.0	27.5			* Floor Noise
750.000	H	20.9			2.7	23.6			46.0	22.4			* Floor Noise

Above 1GHz

Frequency [MHz]	Pol. [H / V]	Reading [dB(uV)] QP / AV / PK			Factor [dB/m]	Level [dB(uV/m)] QP / AV / PK			Limit [dB(uV/m)]	Margin [dB] QP / AV / PK			Remark
4824.000	H			50.4	3.9			54.3	74.0			19.7	
4824.000	H			40.1	3.9			44.0	54.0			10.0	
4824.000	V			46.6	3.9			50.5	74.0			23.5	
4824.000	V			34.2	3.9			38.1	54.0			15.9	
7236.000	H			45.7	5.8			51.5	74.0			22.5	*
7236.000	H			34.8	5.8			40.6	54.0			13.4	*
7236.000	V			47.5	5.8			53.3	74.0			20.7	*
7236.000	V			36.8	5.8			42.6	54.0			11.4	*
9648.000	H			47.8	8.5			56.3	74.0			17.7	*
9648.000	H			38.3	8.5			46.8	54.0			7.2	*
9648.000	V			49.8	8.5			58.3	74.0			15.7	*
9648.000	V			40.7	8.5			49.2	54.0			4.8	*
12060.000	H			46.1	9.7			55.8	74.0			18.2	Floor Noise
12060.000	H			32.9	9.7			42.6	54.0			11.4	Floor Noise

Note: * = Out of Restricted Band.

This frequency is out of the restricted bands, so radiated emission limits specified in Section 15.209 does not apply.

15.247(d):

Radiated emissions which fall in the restricted bands, as defined in Section 15.205(a), must also comply with the radiated emission limits specified in Section 15.209(a) (see Section 15.205(c)).

Axial Direction: YZ-Plane**Below 1GHz**

Frequency [MHz]	Pol. [H / V]	Reading [dB(uV)] QP / AV / PK			Factor [dB/m]	Level [dB(uV/m)] QP / AV / PK			Limit [dB(uV/m)]	Margin [dB] QP / AV / PK			Remark
250.000	H	20.5			-9.1	11.4			46.0	34.6			Floor Noise
500.000	H	21.2			-2.7	18.5			46.0	27.5			* Floor Noise
750.000	H	20.9			2.7	23.6			46.0	22.4			* Floor Noise

Above 1GHz

Frequency [MHz]	Pol. [H / V]	Reading [dB(uV)] QP / AV / PK			Factor [dB/m]	Level [dB(uV/m)] QP / AV / PK			Limit [dB(uV/m)]	Margin [dB] QP / AV / PK			Remark
4824.000	H			49.9	3.9			53.8	74.0			20.2	
4824.000	H		39.6		3.9		43.5		54.0		10.5		
4824.000	V			46.6	3.9			50.5	74.0			23.5	
4824.000	V		37.0		3.9		40.9		54.0		13.1		
7236.000	H			46.5	5.8			52.3	74.0			21.7	*
7236.000	H		34.2		5.8		40.0		54.0		14.0		*
7236.000	V			45.1	5.8			50.9	74.0			23.1	*
7236.000	V		34.2		5.8		40.0		54.0		14.0		*
9648.000	H			48.7	8.5			57.2	74.0			16.8	*
9648.000	H		39.7		8.5		48.2		54.0		5.8		*
9648.000	V			53.9	8.5			62.4	74.0			11.6	*
9648.000	V		44.5		8.5		53.0		54.0		1.0		*
12060.000	H			46.1	9.7			55.8	74.0			18.2	Floor Noise
12060.000	H		32.9		9.7		42.6		54.0		11.4		Floor Noise

Note: * = Out of Restricted Band.

This frequency is out of the restricted bands, so radiated emission limits specified in Section 15.209 does not apply.

15.247(d):

Radiated emissions which fall in the restricted bands, as defined in Section 15.205(a), must also comply with the radiated emission limits specified in Section 15.209(a) (see Section 15.205(c)).

Axial Direction: ZX-Plane**Below 1GHz**

Frequency [MHz]	Pol. [H / V]	Reading [dB(uV)] QP / AV / PK			Factor [dB/m]	Level [dB(uV/m)] QP / AV / PK			Limit [dB(uV/m)]	Margin [dB] QP / AV / PK			Remark
250.000	H	20.5			-9.1	11.4			46.0	34.6			Floor Noise
500.000	H	21.2			-2.7	18.5			46.0	27.5			* Floor Noise
750.000	H	20.9			2.7	23.6			46.0	22.4			* Floor Noise

Above 1GHz

Frequency [MHz]	Pol. [H / V]	Reading [dB(uV)] QP / AV / PK			Factor [dB/m]	Level [dB(uV/m)] QP / AV / PK			Limit [dB(uV/m)]	Margin [dB] QP / AV / PK			Remark
4824.000	H			46.9	3.9			50.8	74.0			23.2	
4824.000	H		37.6		3.9		41.5		54.0		12.5		
4824.000	V			49.4	3.9			53.3	74.0			20.7	
4824.000	V		39.8		3.9		43.7		54.0		10.3		
7236.000	H			47.4	5.8			53.2	74.0			20.8	*
7236.000	H		35.4		5.8		41.2		54.0		12.8		*
7236.000	V			45.3	5.8			51.1	74.0			22.9	*
7236.000	V		33.4		5.8		39.2		54.0		14.8		*
9648.000	H			51.8	8.5			60.3	74.0			12.5	*
9648.000	H		42.6		8.5		51.1		54.0		2.9		*
9648.000	V			49.2	8.5			57.7	74.0			16.3	*
9648.000	V		40.3		8.5		48.8		54.0		5.2		*
12060.000	H			46.1	9.7			55.8	74.0			18.2	Floor Noise
12060.000	H		32.9		9.7		42.6		54.0		11.4		Floor Noise

Note: * = Out of Restricted Band.

This frequency is out of the restricted bands, so radiated emission limits specified in Section 15.209 does not apply.

15.247(d):

Radiated emissions which fall in the restricted bands, as defined in Section 15.205(a), must also comply with the radiated emission limits specified in Section 15.209(a) (see Section 15.205(c)).

Radiated Emission: Mch (2437MHz)

Temp. / Humid.: Below 1GHz 21.4 degree C / 71.5%
 1-6GHz 22.5 degree C / 65.6%
 Above 6GHz 21.9 degree C / 64.7%

Axial Direction: XY-Plane**Below 1GHz**

Frequency [MHz]	Pol. [H / V]	Reading [dB(uV)] QP / AV / PK		Factor [dB/m]	Level [dB(uV/m)] QP / AV / PK		Limit [dB(uV/m)]	Margin [dB] QP / AV / PK		Remark
250.000	H	20.5		-9.1	11.4		46.0	34.6		Floor Noise
500.000	H	21.2		-2.7	18.5		46.0	27.5		* Floor Noise
750.000	H	20.9		2.7	23.6		46.0	22.4		* Floor Noise

Above 1GHz

Frequency [MHz]	Pol. [H / V]	Reading [dB(uV)] QP / AV / PK		Factor [dB/m]	Level [dB(uV/m)] QP / AV / PK		Limit [dB(uV/m)]	Margin [dB] QP / AV / PK		Remark
4874.000	H		48.7	4.0		52.7	74.0		21.3	
4874.000	H		39.4	4.0		43.4	54.0		10.6	
4874.000	V		45.4	4.0		49.4	74.0		24.6	
4874.000	V		34.5	4.0		38.5	54.0		15.5	
7311.000	H		46.6	5.8		52.4	74.0		21.6	
7311.000	H		34.6	5.8		40.4	54.0		13.6	
7311.000	V		47.8	5.8		53.6	74.0		20.4	
7311.000	V		37.0	5.8		42.8	54.0		11.2	
9748.000	H		48.0	8.5		56.5	74.0		17.5	*
9748.000	H		38.2	8.5		46.7	54.0		7.3	*
9748.000	V		49.7	8.5		58.2	74.0		15.8	*
9748.000	V		40.6	8.5		49.1	54.0		4.9	*
12185.000	H		44.5	9.9		54.4	74.0		19.6	Floor Noise
12185.000	H		32.7	9.9		42.6	54.0		11.4	Floor Noise

Note: * = Out of Restricted Band.

This frequency is out of the restricted bands, so radiated emission limits specified in Section 15.209 does not apply.

15.247(d):

Radiated emissions which fall in the restricted bands, as defined in Section 15.205(a), must also comply with the radiated emission limits specified in Section 15.209(a) (see Section 15.205(c)).

Axial Direction: YZ-Plane**Below 1GHz**

Frequency [MHz]	Pol. [H / V]	Reading [dB(uV)] QP / AV / PK			Factor [dB/m]	Level [dB(uV/m)] QP / AV / PK			Limit [dB(uV/m)]	Margin [dB] QP / AV / PK			Remark
250.000	H	20.5			-9.1	11.4			46.0	34.6			Floor Noise
500.000	H	21.2			-2.7	18.5			46.0	27.5			* Floor Noise
750.000	H	20.9			2.7	23.6			46.0	22.4			* Floor Noise

Above 1GHz

Frequency [MHz]	Pol. [H / V]	Reading [dB(uV)] QP / AV / PK			Factor [dB/m]	Level [dB(uV/m)] QP / AV / PK			Limit [dB(uV/m)]	Margin [dB] QP / AV / PK			Remark
4874.000	H			47.9	4.0			51.9	74.0			22.1	
4874.000	H		38.2		4.0		42.2		54.0		11.8		
4874.000	V			47.2	4.0			51.2	74.0			22.8	
4874.000	V		37.1		4.0		41.1		54.0		12.9		
7311.000	H			47.5	5.8			53.3	74.0			20.7	
7311.000	H		35.7		5.8		41.5		54.0		12.5		
7311.000	V			45.3	5.8			51.1	74.0			22.9	
7311.000	V		36.3		5.8		42.1		54.0		11.9		
9748.000	H			48.0	8.5			56.5	74.0			17.5	*
9748.000	H		37.8		8.5		46.3		54.0		7.7		*
9748.000	V			53.9	8.5			62.4	74.0			11.6	*
9748.000	V		44.2		8.5		52.7		54.0		1.3		*
12185.000	H			44.5	9.9			54.4	74.0			19.6	Floor Noise
12185.000	H		32.7		9.9		42.6		54.0		11.4		Floor Noise

Note: * = Out of Restricted Band.

This frequency is out of the restricted bands, so radiated emission limits specified in Section 15.209 does not apply.

15.247(d):

Radiated emissions which fall in the restricted bands, as defined in Section 15.205(a), must also comply with the radiated emission limits specified in Section 15.209(a) (see Section 15.205(c)).

Axial Direction: ZX-Plane**Below 1GHz**

Frequency [MHz]	Pol. [H / V]	Reading [dB(uV)] QP / AV / PK			Factor [dB/m]	Level [dB(uV/m)] QP / AV / PK			Limit [dB(uV/m)]	Margin [dB] QP / AV / PK			Remark
250.000	H	20.5			-9.1	11.4			46.0	34.6			Floor Noise
500.000	H	21.2			-2.7	18.5			46.0	27.5			* Floor Noise
750.000	H	20.9			2.7	23.6			46.0	22.4			* Floor Noise

Above 1GHz

Frequency [MHz]	Pol. [H / V]	Reading [dB(uV)] QP / AV / PK			Factor [dB/m]	Level [dB(uV/m)] QP / AV / PK			Limit [dB(uV/m)]	Margin [dB] QP / AV / PK			Remark
4874.000	H			46.6	4.0			50.6	74.0			23.4	
4874.000	H		36.2		4.0		40.2		54.0		13.8		
4874.000	V			47.7	4.0			51.7	74.0			22.3	
4874.000	V		38.3		4.0		42.3		54.0		11.7		
7311.000	H			46.8	5.8			52.6	74.0			21.4	
7311.000	H		35.4		5.8		41.2		54.0		12.8		
7311.000	V			46.4	5.8			52.2	74.0			21.8	
7311.000	V		35.0		5.8		40.8		54.0		13.2		
9748.000	H			53.5	8.5			62.0	74.0			12.0	*
9748.000	H		43.9		8.5		52.4		54.0		1.6		*
9748.000	V			50.1	8.5			58.6	74.0			15.4	*
9748.000	V		40.8		8.5		49.3		54.0		4.7		*
12185.000	H			44.5	9.9			54.4	74.0			19.6	Floor Noise
12185.000	H		32.7		9.9		42.6		54.0		11.4		Floor Noise

Note: * = Out of Restricted Band.

This frequency is out of the restricted bands, so radiated emission limits specified in Section 15.209 does not apply.

15.247(d):

Radiated emissions which fall in the restricted bands, as defined in Section 15.205(a), must also comply with the radiated emission limits specified in Section 15.209(a) (see Section 15.205(c)).

Radiated Emission: Hch (2462MHz)

Temp. / Humid.: Below 1GHz 21.4 degree C / 71.5%
 1-6GHz 22.5 degree C / 65.6%
 Above 6GHz 21.9 degree C / 64.7%

Axial Direction: XY-Plane**Below 1GHz**

Frequency [MHz]	Pol. [H / V]	Reading [dB(uV)] QP / AV / PK		Factor [dB/m]	Level [dB(uV/m)] QP / AV / PK		Limit [dB(uV/m)]	Margin [dB] QP / AV / PK		Remark
250.000	H	20.5		-9.1	11.4		46.0	34.6		Floor Noise
500.000	H	21.2		-2.7	18.5		46.0	27.5		* Floor Noise
750.000	H	20.9		2.7	23.6		46.0	22.4		* Floor Noise

Above 1GHz

Frequency [MHz]	Pol. [H / V]	Reading [dB(uV)] QP / AV / PK		Factor [dB/m]	Level [dB(uV/m)] QP / AV / PK		Limit [dB(uV/m)]	Margin [dB] QP / AV / PK		Remark
4924.000	H		46.3	4.1		50.4	74.0		23.6	
4924.000	H		36.4	4.1		40.5	54.0		13.5	
4924.000	V		45.7	4.1		49.8	74.0		24.2	
4924.000	V		33.6	4.1		37.7	54.0		16.3	
7386.000	H		48.4	5.8		54.2	74.0		19.8	
7386.000	H		36.5	5.8		42.3	54.0		11.7	
7386.000	V		50.1	5.8		55.9	74.0		18.1	
7386.000	V		39.6	5.8		45.4	54.0		8.6	
9848.000	H		48.7	8.6		57.3	74.0		16.7	*
9848.000	H		38.7	8.6		47.3	54.0		6.7	*
9848.000	V		50.5	8.6		59.1	74.0		14.9	*
9848.000	V		41.2	8.6		49.8	54.0		4.2	*
12310.000	H		44.1	9.7		53.8	74.0		20.2	Floor Noise
12310.000	H		31.9	9.7		41.6	54.0		12.4	Floor Noise

Note: * = Out of Restricted Band.

This frequency is out of the restricted bands, so radiated emission limits specified in Section 15.209 does not apply.

15.247(d):

Radiated emissions which fall in the restricted bands, as defined in Section 15.205(a), must also comply with the radiated emission limits specified in Section 15.209(a) (see Section 15.205(c)).

Axial Direction: YZ-Plane**Below 1GHz**

Frequency [MHz]	Pol. [H / V]	Reading [dB(uV)] QP / AV / PK			Factor [dB/m]	Level [dB(uV/m)] QP / AV / PK			Limit [dB(uV/m)]	Margin [dB] QP / AV / PK			Remark
250.000	H	20.5			-9.1	11.4			46.0	34.6			Floor Noise
500.000	H	21.2			-2.7	18.5			46.0	27.5			* Floor Noise
750.000	H	20.9			2.7	23.6			46.0	22.4			* Floor Noise

Above 1GHz

Frequency [MHz]	Pol. [H / V]	Reading [dB(uV)] QP / AV / PK			Factor [dB/m]	Level [dB(uV/m)] QP / AV / PK			Limit [dB(uV/m)]	Margin [dB] QP / AV / PK			Remark
4924.000	H			46.9	4.1			51.0	74.0			23.0	
4924.000	H		36.8		4.1		40.9		54.0		13.1		
4924.000	V			47.7	4.1			51.8	74.0			22.2	
4924.000	V		36.9		4.1		41.0		54.0		13.0		
7386.000	H			50.2	5.8			56.0	74.0			18.0	
7386.000	H		38.3		5.8		44.1		54.0		9.9		
7386.000	V			48.6	5.8			54.4	74.0			19.6	
7386.000	V		37.9		5.8		43.7		54.0		10.3		
9848.000	H			48.4	8.6			57.0	74.0			17.0	*
9848.000	H		38.8		8.6		47.4		54.0		6.6		*
12310.000	H			44.1	9.7			53.8	74.0			20.2	Floor Noise
12310.000	H		31.9		9.7		41.6		54.0		12.4		Floor Noise

Note: * = Out of Restricted Band.

This frequency is out of the restricted bands, so radiated emission limits specified in Section 15.209 does not apply.

15.247(d):

Radiated emissions which fall in the restricted bands, as defined in Section 15.205(a), must also comply with the radiated emission limits specified in Section 15.209(a) (see Section 15.205(c)).

Axial Direction: ZX-Plane**Below 1GHz**

Frequency [MHz]	Pol. [H / V]	Reading [dB(uV)] QP / AV / PK			Factor [dB/m]	Level [dB(uV/m)] QP / AV / PK			Limit [dB(uV/m)]	Margin [dB] QP / AV / PK			Remark
250.000	H	20.5			-9.1	11.4			46.0	34.6			Floor Noise
500.000	H	21.2			-2.7	18.5			46.0	27.5			* Floor Noise
750.000	H	20.9			2.7	23.6			46.0	22.4			* Floor Noise

Above 1GHz

Frequency [MHz]	Pol. [H / V]	Reading [dB(uV)] QP / AV / PK			Factor [dB/m]	Level [dB(uV/m)] QP / AV / PK			Limit [dB(uV/m)]	Margin [dB] QP / AV / PK			Remark
4924.000	H			46.1	4.1			50.2	74.0			23.8	
4924.000	H		35.5		4.1		39.6		54.0		14.4		
4924.000	V			47.6	4.1			51.7	74.0			22.3	
4924.000	V		37.7		4.1		41.8		54.0		12.2		
7386.000	H			49.3	5.8			55.1	74.0			18.9	
7386.000	H		38.1		5.8		43.9		54.0		10.1		
7386.000	V			46.9	5.8			52.7	74.0			21.3	
7386.000	V		35.9		5.8		41.7		54.0		12.3		
9848.000	H			54.7	8.6			63.3	74.0			10.7	*
9848.000	H		44.8		8.6		53.4		54.0		0.6		*
9848.000	V			49.9	8.6			58.5	74.0			15.5	*
9848.000	V		40.0		8.6		48.6		54.0		5.4		*
12310.000	H			44.1	9.7			53.8	74.0			20.2	Floor Noise
12310.000	H		31.9		9.7		41.6		54.0		12.4		Floor Noise

Note: * = Out of Restricted Band.

This frequency is out of the restricted bands, so radiated emission limits specified in Section 15.209 does not apply.

15.247(d):

Radiated emissions which fall in the restricted bands, as defined in Section 15.205(a), must also comply with the radiated emission limits specified in Section 15.209(a) (see Section 15.205(c)).

Product	: Wireless LAN UNIT	Model	: WCAAVDX2
Serial No.	: 2	Test Standard	: FCC Part15 Subpart C §15.247(d)
Power Supply	: DC 5.00V		
Operator	: Masashi Tsukui		
Remark	: Transmitting Mode		
	: IEEE 802.11g (6Mbps)		

Radiated Emission: Lch (2412MHz)

Temp. / Humid.: Below 1GHz 21.4 degree C / 71.5%
 1-6GHz 22.5 degree C / 65.6%
 Above 6GHz 21.9 degree C / 64.7%

Axial Direction: XY-Plane

Below 1GHz

Frequency [MHz]	Pol. [H / V]	Reading [dB(uV)]			Factor [dB/m]	Level [dB(uV/m)]			Limit [dB(uV/m)]	Margin [dB]			Remark
		QP	AV	PK		QP	AV	PK		QP	AV	PK	
250.000	H	20.5			-9.1	11.4			46.0	34.6			Floor Noise
500.000	H	21.2			-2.7	18.5			46.0	27.5			* Floor Noise
750.000	H	20.9			2.7	23.6			46.0	22.4			* Floor Noise

Above 1GHz

Frequency [MHz]	Pol. [H / V]	Reading [dB(uV)]			Factor [dB/m]	Level [dB(uV/m)]			Limit [dB(uV/m)]	Margin [dB]			Remark
		QP	AV	PK		QP	AV	PK		QP	AV	PK	
4824.000	H			44.2	3.9		48.1	74.0			25.9		Floor Noise
4824.000	H		30.8		3.9		34.7	54.0			19.3		Floor Noise
4824.000	V			48.0	3.9		51.9	74.0			22.1		
4824.000	V		33.5		3.9		37.4	54.0			16.6		
7236.000	H			43.7	5.8		49.5	74.0			24.5		* Floor Noise
7236.000	H		32.6		5.8		38.4	54.0			15.6		* Floor Noise
9648.000	H			43.4	8.5		51.9	74.0			22.1		* Floor Noise
9648.000	H		31.5		8.5		40.0	54.0			14.0		* Floor Noise
12060.000	H			46.1	9.7		55.8	74.0			18.2		Floor Noise
12060.000	H		32.9		9.7		42.6	54.0			11.4		Floor Noise

Note: * = Out of Restricted Band.

This frequency is out of the restricted bands, so radiated emission limits specified in Section 15.209 does not apply.

15.247(d):

Radiated emissions which fall in the restricted bands, as defined in Section 15.205(a), must also comply with the radiated emission limits specified in Section 15.209(a) (see Section 15.205(c)).

Axial Direction: YZ-Plane**Below 1GHz**

Frequency [MHz]	Pol. [H / V]	Reading [dB(uV)] QP / AV / PK			Factor [dB/m]	Level [dB(uV/m)] QP / AV / PK			Limit [dB(uV/m)]	Margin [dB] QP / AV / PK			Remark
250.000	H	20.5			-9.1	11.4			46.0	34.6			Floor Noise
500.000	H	21.2			-2.7	18.5			46.0	27.5			* Floor Noise
750.000	H	20.9			2.7	23.6			46.0	22.4			* Floor Noise

Above 1GHz

Frequency [MHz]	Pol. [H / V]	Reading [dB(uV)] QP / AV / PK			Factor [dB/m]	Level [dB(uV/m)] QP / AV / PK			Limit [dB(uV/m)]	Margin [dB] QP / AV / PK			Remark
4824.000	H			44.2	3.9			48.1	74.0			25.9	Floor Noise
4824.000	H		30.8		3.9		34.7		54.0		19.3		Floor Noise
4824.000	V			45.4	3.9			49.3	74.0			24.7	
4824.000	V		31.7		3.9		35.6		54.0		18.4		
7236.000	H			43.7	5.8			49.5	74.0			24.5	* Floor Noise
7236.000	H		32.6		5.8		38.4		54.0		15.6		* Floor Noise
9648.000	H			43.4	8.5			51.9	74.0			22.1	* Floor Noise
9648.000	H		31.5		8.5		40.0		54.0		14.0		* Floor Noise
12060.000	H			46.1	9.7			55.8	74.0			18.2	Floor Noise
12060.000	H		32.9		9.7		42.6		54.0		11.4		Floor Noise

Note: * = Out of Restricted Band.

This frequency is out of the restricted bands, so radiated emission limits specified in Section 15.209 does not apply.

15.247(d):

Radiated emissions which fall in the restricted bands, as defined in Section 15.205(a), must also comply with the radiated emission limits specified in Section 15.209(a) (see Section 15.205(c)).

Axial Direction: ZX-Plane**Below 1GHz**

Frequency [MHz]	Pol. [H / V]	Reading [dB(uV)] QP / AV / PK			Factor [dB/m]	Level [dB(uV/m)] QP / AV / PK			Limit [dB(uV/m)]	Margin [dB] QP / AV / PK			Remark
250.000	H	20.5			-9.1	11.4			46.0	34.6			Floor Noise
500.000	H	21.2			-2.7	18.5			46.0	27.5			* Floor Noise
750.000	H	20.9			2.7	23.6			46.0	22.4			* Floor Noise

Above 1GHz

Frequency [MHz]	Pol. [H / V]	Reading [dB(uV)] QP / AV / PK			Factor [dB/m]	Level [dB(uV/m)] QP / AV / PK			Limit [dB(uV/m)]	Margin [dB] QP / AV / PK			Remark
4824.000	H			44.2	3.9		48.1	74.0			25.9		Floor Noise
4824.000	H		30.8		3.9		34.7	54.0		19.3			Floor Noise
4824.000	V			47.6	3.9		51.5	74.0			22.5		
4824.000	V		33.6		3.9		37.5	54.0		16.5			
7236.000	H			43.7	5.8		49.5	74.0			24.5		* Floor Noise
7236.000	H		32.6		5.8		38.4	54.0		15.6			* Floor Noise
9648.000	H			43.4	8.5		51.9	74.0			22.1		* Floor Noise
9648.000	H		31.5		8.5		40.0	54.0		14.0			* Floor Noise
12060.000	H			46.1	9.7		55.8	74.0			18.2		Floor Noise
12060.000	H		32.9		9.7		42.6	54.0		11.4			Floor Noise

Note: * = Out of Restricted Band.

This frequency is out of the restricted bands, so radiated emission limits specified in Section 15.209 does not apply.

15.247(d):

Radiated emissions which fall in the restricted bands, as defined in Section 15.205(a), must also comply with the radiated emission limits specified in Section 15.209(a) (see Section 15.205(c)).

Radiated Emission: Mch (2437MHz)

Temp. / Humid.: Below 1GHz 21.4 degree C / 71.5%
 1-6GHz 22.5 degree C / 65.6%
 Above 6GHz 21.4 degree C / 71.5%

Axial Direction: XY-Plane**Below 1GHz**

Frequency [MHz]	Pol. [H / V]	Reading [dB(uV)] QP / AV / PK		Factor [dB/m]	Level [dB(uV/m)] QP / AV / PK		Limit [dB(uV/m)]	Margin [dB] QP / AV / PK		Remark
250.000	H	20.5		-9.1	11.4		46.0	34.6		Floor Noise
500.000	H	21.2		-2.7	18.5		46.0	27.5		* Floor Noise
750.000	H	20.9		2.7	23.6		46.0	22.4		* Floor Noise

Above 1GHz

Frequency [MHz]	Pol. [H / V]	Reading [dB(uV)] QP / AV / PK		Factor [dB/m]	Level [dB(uV/m)] QP / AV / PK		Limit [dB(uV/m)]	Margin [dB] QP / AV / PK		Remark
4874.000	H		43.5	4.0		47.5	74.0		26.5	Floor Noise
4874.000	H	31.0		4.0		35.0	54.0	19.0		Floor Noise
7311.000	H		42.3	5.8		48.1	74.0		25.9	Floor Noise
7311.000	H	31.7		5.8		37.5	54.0	16.5		Floor Noise
9748.000	H		42.6	8.5		51.1	74.0		22.9	* Floor Noise
9748.000	H	30.8		8.5		39.3	54.0	14.7		* Floor Noise
12185.000	H		44.5	9.9		54.4	74.0		19.6	Floor Noise
12185.000	H	32.7		9.9		42.6	54.0	11.4		Floor Noise

Note: * = Out of Restricted Band.

This frequency is out of the restricted bands, so radiated emission limits specified in Section 15.209 does not apply.

15.247(d):

Radiated emissions which fall in the restricted bands, as defined in Section 15.205(a), must also comply with the radiated emission limits specified in Section 15.209(a) (see Section 15.205(c)).

Axial Direction: YZ-Plane**Below 1GHz**

Frequency [MHz]	Pol. [H / V]	Reading [dB(uV)] QP / AV / PK			Factor [dB/m]	Level [dB(uV/m)] QP / AV / PK			Limit [dB(uV/m)]	Margin [dB] QP / AV / PK			Remark
250.000	H	20.5			-9.1	11.4			46.0	34.6			Floor Noise
500.000	H	21.2			-2.7	18.5			46.0	27.5			* Floor Noise
750.000	H	20.9			2.7	23.6			46.0	22.4			* Floor Noise

Above 1GH

Frequency [MHz]	Pol. [H / V]	Reading [dB(uV)] QP / AV / PK			Factor [dB/m]	Level [dB(uV/m)] QP / AV / PK			Limit [dB(uV/m)]	Margin [dB] QP / AV / PK			Remark
4874.000	H			43.5	4.0			47.5	74.0			26.5	Floor Noise
4874.000	H		31.0		4.0		35.0		54.0		19.0		Floor Noise
7311.000	H			42.3	5.8			48.1	74.0			25.9	Floor Noise
7311.000	H		31.7		5.8		37.5		54.0		16.5		Floor Noise
9748.000	H			42.6	8.5			51.1	74.0			22.9	* Floor Noise
9748.000	H		30.8		8.5		39.3		54.0		14.7		* Floor Noise
12185.000	H			44.5	9.9			54.4	74.0			19.6	Floor Noise
12185.000	H		32.7		9.9		42.6		54.0		11.4		Floor Noise

Note: * = Out of Restricted Band.

This frequency is out of the restricted bands, so radiated emission limits specified in Section 15.209 does not apply.

15.247(d):

Radiated emissions which fall in the restricted bands, as defined in Section 15.205(a), must also comply with the radiated emission limits specified in Section 15.209(a) (see Section 15.205(c)).

Axial Direction: ZX-Plane**Below 1GHz**

Frequency [MHz]	Pol. [H / V]	Reading [dB(uV)] QP / AV / PK			Factor [dB/m]	Level [dB(uV/m)] QP / AV / PK			Limit [dB(uV/m)]	Margin [dB] QP / AV / PK			Remark
250.000	H	20.5			-9.1	11.4			46.0	34.6			Floor Noise
500.000	H	21.2			-2.7	18.5			46.0	27.5			* Floor Noise
750.000	H	20.9			2.7	23.6			46.0	22.4			* Floor Noise

Above 1GHz

Frequency [MHz]	Pol. [H / V]	Reading [dB(uV)] QP / AV / PK			Factor [dB/m]	Level [dB(uV/m)] QP / AV / PK			Limit [dB(uV/m)]	Margin [dB] QP / AV / PK			Remark
4874.000	H			43.5	4.0			47.5	74.0			26.5	Floor Noise
4874.000	H		31.0		4.0		35.0		54.0		19.0		Floor Noise
4874.000	V			45.8	4.0			49.8	74.0			24.2	
4874.000	V		32.7		4.0		36.7		54.0		17.3		
7311.000	H			42.3	5.8			48.1	74.0			25.9	Floor Noise
7311.000	H		31.7		5.8		37.5		54.0		16.5		Floor Noise
9748.000	H			42.6	8.5			51.1	74.0			22.9	* Floor Noise
9748.000	H		30.8		8.5		39.3		54.0		14.7		* Floor Noise
12185.000	H			44.5	9.9			54.4	74.0			19.6	Floor Noise
12185.000	H		32.7		9.9		42.6		54.0		11.4		Floor Noise

Note: * = Out of Restricted Band.

This frequency is out of the restricted bands, so radiated emission limits specified in Section 15.209 does not apply.

15.247(d):

Radiated emissions which fall in the restricted bands, as defined in Section 15.205(a), must also comply with the radiated emission limits specified in Section 15.209(a) (see Section 15.205(c)).

Radiated Emission: Hch (2462MHz)

Temp. / Humid.: Below 1GHz 21.4 degree C / 71.5%
 1-6GHz 21.9 degree C / 64.7%
 Above 6GHz 21.4 degree C / 71.5%

Axial Direction: XY-Plane**Below 1GHz**

Frequency [MHz]	Pol. [H / V]	Reading [dB(uV)] QP / AV / PK		Factor [dB/m]	Level [dB(uV/m)] QP / AV / PK		Limit [dB(uV/m)]	Margin [dB] QP / AV / PK		Remark
250.000	H	20.5		-9.1	11.4		46.0	34.6		Floor Noise
500.000	H	21.2		-2.7	18.5		46.0	27.5		* Floor Noise
750.000	H	20.9		2.7	23.6		46.0	22.4		* Floor Noise

Above 1GHz

Frequency [MHz]	Pol. [H / V]	Reading [dB(uV)] QP / AV / PK		Factor [dB/m]	Level [dB(uV/m)] QP / AV / PK		Limit [dB(uV/m)]	Margin [dB] QP / AV / PK		Remark
4924.000	H		43.3	4.1		47.4	74.0		26.6	Floor Noise
4924.000	H	30.9		4.1		35.0	54.0	19.0		Floor Noise
7386.000	H		44.4	5.8		50.2	74.0		23.8	Floor Noise
7386.000	H	32.7		5.8		38.5	54.0	15.5		Floor Noise
9848.000	H		42.3	8.6		50.9	74.0		23.1	* Floor Noise
9848.000	H	31.1		8.6		39.7	54.0	14.3		* Floor Noise
12310.000	H		44.1	9.7		53.8	74.0		20.2	Floor Noise
12310.000	H	31.9		9.7		41.6	54.0	12.4		Floor Noise

Note: * = Out of Restricted Band.

This frequency is out of the restricted bands, so radiated emission limits specified in Section 15.209 does not apply.

15.247(d):

Radiated emissions which fall in the restricted bands, as defined in Section 15.205(a), must also comply with the radiated emission limits specified in Section 15.209(a) (see Section 15.205(c)).

Axial Direction: YZ-Plane**Below 1GHz**

Frequency [MHz]	Pol. [H / V]	Reading [dB(uV)] QP / AV / PK			Factor [dB/m]	Level [dB(uV/m)] QP / AV / PK			Limit [dB(uV/m)]	Margin [dB] QP / AV / PK			Remark
250.000	H	20.5			-9.1	11.4			46.0	34.6			Floor Noise
500.000	H	21.2			-2.7	18.5			46.0	27.5			* Floor Noise
750.000	H	20.9			2.7	23.6			46.0	22.4			* Floor Noise

Above 1GHz

Frequency [MHz]	Pol. [H / V]	Reading [dB(uV)] QP / AV / PK			Factor [dB/m]	Level [dB(uV/m)] QP / AV / PK			Limit [dB(uV/m)]	Margin [dB] QP / AV / PK			Remark
4924.000	H			43.3	4.1			47.4	74.0			26.6	Floor Noise
4924.000	H		30.9		4.1		35.0		54.0		19.0		Floor Noise
7386.000	H			44.4	5.8			50.2	74.0			23.8	Floor Noise
7386.000	H		32.7		5.8		38.5		54.0		15.5		Floor Noise
9848.000	H			42.3	8.6			50.9	74.0			23.1	* Floor Noise
9848.000	H		31.1		8.6		39.7		54.0		14.3		* Floor Noise
12310.000	H			44.1	9.7			53.8	74.0			20.2	Floor Noise
12310.000	H		31.9		9.7		41.6		54.0		12.4		Floor Noise

Note: * = Out of Restricted Band.

This frequency is out of the restricted bands, so radiated emission limits specified in Section 15.209 does not apply.

15.247(d):

Radiated emissions which fall in the restricted bands, as defined in Section 15.205(a), must also comply with the radiated emission limits specified in Section 15.209(a) (see Section 15.205(c)).

Axial Direction: ZX-Plane**Below 1GHz**

Frequency [MHz]	Pol. [H / V]	Reading [dB(uV)] QP / AV / PK			Factor [dB/m]	Level [dB(uV/m)] QP / AV / PK			Limit [dB(uV/m)]	Margin [dB] QP / AV / PK			Remark
250.000	H	20.5			-9.1	11.4			46.0	34.6			Floor Noise
500.000	H	21.2			-2.7	18.5			46.0	27.5			* Floor Noise
750.000	H	20.9			2.7	23.6			46.0	22.4			* Floor Noise

Above 1GHz

Frequency [MHz]	Pol. [H / V]	Reading [dB(uV)] QP / AV / PK			Factor [dB/m]	Level [dB(uV/m)] QP / AV / PK			Limit [dB(uV/m)]	Margin [dB] QP / AV / PK			Remark
4924.000	H			43.3	4.1			47.4	74.0			26.6	Floor Noise
4924.000	H		30.9		4.1		35.0		54.0		19.0		Floor Noise
7386.000	H			44.4	5.8			50.2	74.0			23.8	Floor Noise
7386.000	H		32.7		5.8		38.5		54.0		15.5		Floor Noise
9848.000	H			42.3	8.6			50.9	74.0			23.1	* Floor Noise
9848.000	H		31.1		8.6		39.7		54.0		14.3		* Floor Noise
12310.000	H			44.1	9.7			53.8	74.0			20.2	Floor Noise
12310.000	H		31.9		9.7		41.6		54.0		12.4		Floor Noise

Note: * = Out of Restricted Band.

This frequency is out of the restricted bands, so radiated emission limits specified in Section 15.209 does not apply.

15.247(d):

Radiated emissions which fall in the restricted bands, as defined in Section 15.205(a), must also comply with the radiated emission limits specified in Section 15.209(a) (see Section 15.205(c)).

11 Peak Power Spectral Density

11.1 Test Setup

The test is performed in accordance with FCC Document "Measurement of Transmission Systems Operating under section 15.247". PSD Option1 is used.

The spectrum analyzer was connected to the transmitter output port through the RF cable.

Spectrum Analyzer Setting:

Detector Mode	Peak
RBW	3kHz
VBW	10kHz
Span	1.5MHz
Sweep Time	500s

11.2 Test Results

Serial No. : 1
 Power : DC 5.00V
 Mode : Transmitting Mode (1ch, 6ch, 11ch)
 IEEE 802.11b: DBPSK (1Mbps)
 IEEE 802.11g: BPSK (6Mbps)
 Temperature : 23.3 degree C
 Humidity : 60.0 %
 Regulation : FCC Part15 C §15.247 (e)

Channel	Frequency [MHz]	Reading [dBm]	Cable Loss1 [dB]	Cable Loss2 [dB]	Result [dBm]	Limit [dBm/3kHz]
IEEE 802.11b: DBPSK (1Mbps)						
1ch (Lowest)	2413.9915	2.98	0.67	0.50	4.15	<=8
6ch (Middle)	2438.99177	3.32	0.67	0.50	4.49	<=8
11ch (Highest)	2463.99154	3.02	0.68	0.50	4.20	<=8
IEEE 802.11g: BPSK (6Mbps)						
1ch (Lowest)	2411.99	-11.32	0.67	0.50	-10.15	<=8
6ch (Middle)	2436.99	-10.86	0.67	0.50	-9.69	<=8
11ch (Highest)	2461.99	-10.86	0.68	0.50	-9.68	<=8

Result = Reading + Cable Loss

Note: Cable Loss1: RF Cable

Cable Loss2: Conversion cable used for connecting to SMA type

The spectrum data are attached next page.

Data of Peak Power Spectral Density

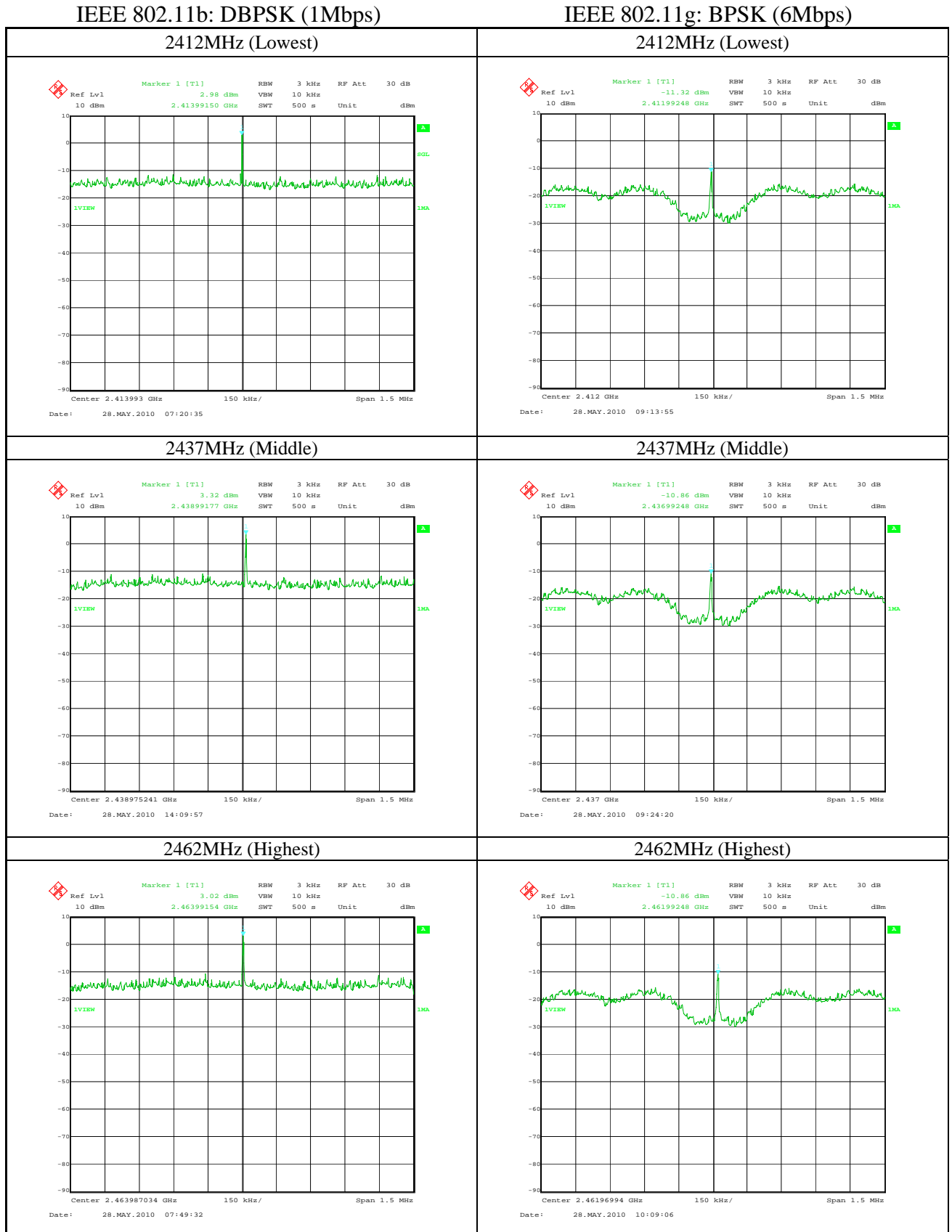

12 Photos of Tested EUT and Test Setup

Setup photo with EUT has been submitted as separate document named “Test Setup Photos (10017F)”.

Appendix 1: Certificate of Accreditation

**United States Department of Commerce
National Institute of Standards and Technology**

NVLAP[®]

Certificate of Accreditation to ISO/IEC 17025:2005

NVLAP LAB CODE: 200607-0

Taiyo Yuden Co., Ltd. EMC Center
Takasaki-shi Gunma 370-3347
JAPAN

*is accredited by the National Voluntary Laboratory Accreditation Program for specific services,
listed on the Scope of Accreditation, for:*

ELECTROMAGNETIC COMPATIBILITY AND TELECOMMUNICATIONS

*This laboratory is accredited in accordance with the recognized International Standard ISO/IEC 17025:2005.
This accreditation demonstrates technical competence for a defined scope and the operation of a laboratory quality
management system (refer to joint ISO-ILAC-IAF Communique dated January 2009).*

2009-10-01 through 2010-09-30
Effective dates



Dally S. Bruce
For the National Institute of Standards and Technology

NVLAP-01C (REV. 2009-01-28)

Appendix 2: Test Instruments

1. Conducted Emission Test

Instrument	Manufacturer	Model No.	Serial No.	Calibration Date (Interval: 1 year)	
Shielded Room	TDK Co., Ltd	DA-06912	-	-	●
EMI Test Receiver	Rohde & Schwarz	ESHS 10	100005	21 July 2009	●
Spectrum Analyzer	Agilent Technologies	8563E	3416A02230	21 July 2009	●
AMN / LISN	KYORITSU ELECTRICAL WORK	KNW-407	8-680-1	16 December 2009	●
		KNW-242	8-818-8		○
Cable	SUHNER	RG223	CE-1	31 July 2009	●
		RG223	CE-2		●
		RG214	CE-3		●
Attenuator	KYORITSU	KPD-602	5K325		●
RF Selector	TOYO Corporation	NS4900	0302-009		●
Hygro thermograph	SEKONIC	ST-200	HD01-000779	26 October 2009	●
Software	TOYO Corporation	EP5/CE Ver.2.0	0208085	-	●

2. Conducted RF Test via Antenna Terminal

Instrument	Manufacturer	Model No.	Serial No.	Calibration Date (Interval: 1 year)	
Spectrum Analyzer	Rohde & Schwarz	FSIQ26	840061/0004	22 February 2010	●
	Agilent Technologies	E4446A	US42070181	22 October 2009	○
Power Meter	Rohde & Schwarz	NRVD	838380/0043	-	○
	Agilent Technologies	N1911A	MY45100612	19 February 2010	●
Power Sensor	Rohde & Schwarz	NRV-Z1	838357/0001	-	○
	Agilent Technologies	N1922A	MY45240439	19 February 2010	●
RF Cable	SUHNER	SUCOFLEX 104	RF2-2	1 July 2009	●
		SUCOFLEX 104E	RF3-3	1 July 2009	○
Power Divider	Aeroflex / Inmet	6005-03	RF-8	1 July 2009	○
Multi Meter	Advantest	R6451A	67840312	7 December 2009	●
	Agilent Technologies	34401A	MY41038383	8 July 2009	○
Hygro thermograph	SEKONIC	ST-200	HD01-000797	7 May 2010	●

Note:

- : Applied by measurement.
- : Not applied by measurement.

3. Radiated Emission Test

Instrument	Manufacturer	Model No.	Serial No.	Calibration Date (Interval: 1 year)	
10m Anechoic Chamber	TDK Co., Ltd.	DA-06912	-	2 February 2010	●
EMI Test Receiver	Rohde & Schwarz	ESCS 30	100148	21 July 2009	●
Spectrum Analyzer	Agilent Technologies	E4407B	MY44221019	29 April 2010	●
		E4446A	US42070181	22 October 2009	●
Amplifier	Agilent Technologies	83017A	3950M00169	30 July 2009	●
		8447D	2944A06812		●
RF Selector	TOYO Corporation	NS4900	0302-010		●
Tunable Filter	TOYO Corporation	NF-49BT	No.1		●
RF Filter	Microtronics	BRM50702-01	020		●
RF Cable	SUHNER	RG214	RG1		●
			RG3		●
			RG5		●
			RG7		●
			RG8		●
	HP	HP8120-4782	163 9232	30 July 2009	●
	SUHNER	SUCOFLEX 106	SU1		●
		SUCOFLEX 103	SU5		●
	HP	85381C	No.3		●
	Attenuator	KYORITSU	KPD-602	220142	●
Antenna	Schwarzbeck	BBA9106	No.3	16 December 2009	○
		UHALP9108-A	0160		○
		VULB9160	3179		●
		VHA9103	No.3 (+D3-1, 2)		○
		UHA9105	No.3		○
	EMCO	3115	9403-4232	3 February 2010	●
		3116	9311-2227		●
Digital Multi Meter	Agilent Technologies	34401A	MY41038383	8 July 2009	●
Hygro Thermograph	SEKONIC	ST-50	HE01-00511	2 March 2010	●
Software	TOYO Corporation	EP5/RE Ver.3.7.0	0208086	-	●

Note:

- : Applied by measurement.
- : Not applied by measurement.