



RADIO TEST REPORT

Test Report No.: 30GE0098-YK-D-R1

Applicant : RICOH COMPANY LTD.
Type of Equipment : Option(s) for Radiocommunications
Model No. : R-WL54M1N
FCC ID : BBP-WLRWL542
Test regulation : FCC Part15 Subpart E: 2010
Test result : Complied

1. This test report shall not be reproduced in full or partial, without the written approval of UL Japan, Inc.
2. The results in this report apply only to the sample tested.
3. This sample tested is in compliance with the limits of the above regulation.
4. The test results in this test report are traceable to the national or international standards.
5. This test report must not be used by the customer to claim product certification, approval, or endorsement by NVLAP, NIST, or any agency of the Federal Government.
6. This report is a revised version of 30GE0098-YK-D. 30GE0098-YK-D is replaced with this report.

Date of test: February 18, 25-27 and March 1-3, 2010

Tested by: T. Arai

Tatsuya Arai
Engineer of EMC Service

M. Hosaka

Makoto Hosaka
Engineer of EMC Service

A. Hayashi

Akio Hayashi
Engineer of EMC Service

Approved by: I. Isozaki

Ichiro Isozaki
Leader of EMC Service

UL Japan, Inc.
Shonan EMC Lab.

1-22-3 Megumigaoka, Hiratsuka-shi, Kanagawa-ken, 259-1220 JAPAN

Telephone: +81 463 50 6400

Facsimile: +81 463 50 6401

MF060b (06.08.09)

Table of Contents	Page
1 Applicant information	3
2 Equipment under test (E.U.T.)	3
3 Test specification, procedures and results	4
4 System test configuration	7
5 Conducted Emission	9
6 26dB Bandwidth & Occupied Bandwidth (99%)	10
7 Maximum Peak Output Power	10
8 Peak Power Spectral Density	10
9 Peak Excursion Ratio	10
10 Out of Band Emissions (Antenna Port Conducted)	10
11 Out of band emissions (Radiated)	11
Contents of Appendixes	12
APPENDIX 1: Photographs of test setup	13
APPENDIX 2: Test data	17
APPENDIX 3: Test instruments	59

UL Japan, Inc.

Shonan EMC Lab.

1-22-3 Megumigaoka, Hiratsuka-shi, Kanagawa-ken, 259-1220 JAPAN

Telephone: +81 463 50 6400

Facsimile: +81 463 50 6401

1 Applicant information

Company Name : RICOH COMPANY, LTD.
Address : 1-3-6 Nakamagome, Ohta-ku, Tokyo, 143-8555 Japan
Telephone Number : +81-3-6890-3804
Facsimile Number : +81-3-5742-5489
Contact Person : Kazuki Kitazawa

2 Equipment under test (E.U.T.)

2.1 Identification of E.U.T.

Type of Equipment : Option(s) for Radiocommunications
Model No. : R-WL54M1N
Serial No. : 91290017
Rating : DC3.3V
Country of Mass-production : Japan
Receipt Date of Sample : Production prototype
(Not for Sale: This sample is equivalent to mass-produced items.)
Condition of EUT : No modification by the test lab.
Modification of EUT : February 17, 2010

2.2 Product description

Model: R-WL54M1N (referred to as the EUT in this report) is a Option(s) for Radiocommunications.

Equipment type : Transceiver
Frequency of operation : [11b/g] 2412-2462MHz *1)
[11a] 5180-5320MHz
Clock frequency : 11MHz, 20MHz
Bandwidth & channel spacing : [11b/g] 22MHz & 5MHz
[11a] 18MHz & 20MHz
Type of modulation : IEEE802.11a: OFDM (BPSK, QPSK, 16QAM, 64QAM)
IEEE802.11b: DSSS (DBPSK, DQPSK, CCK)
IEEE802.11g: OFDM (BPSK, QPSK, 16QAM, 64QAM)
Antenna type : Monopole Antenna
Antenna 1: Transmitting & Receiving
Antenna 2: Receiving only
Antenna connector type : None
Antenna gain : [11b/g] max +3dBi
[11a] max +4dBi
ITU code : D1D, G1D
Operation temperature range : 0 ~ +65 deg.C.

*1) Refer to 30GE0098-YK-C-R1, FCC part 15C (FCC 15.247) report.

FCC 15.31 (e)

The RF Module has its own regulator.

The RF Module is constantly provided voltage (DC3.3V, 2.9V, 2.8V, and 1.2V) through its own regulator regardless of input voltage. Therefore, this EUT complies with the requirement.

FCC Part15.203 Antenna requirement

The antenna is not removable from the EUT. Therefore, the equipment complies with the antenna requirement of Section 15.203.

UL Japan, Inc.

Shonan EMC Lab.

1-22-3 Megumigaoka, Hiratsuka-shi, Kanagawa-ken, 259-1220 JAPAN

Telephone: +81 463 50 6400

Facsimile: +81 463 50 6401

3 Test specification, procedures and results

3.1 Test specification

Test specification : FCC Part 15 Subpart E: 2010, final revised on January 22, 2010 and effective March 1, 2010
 Title : FCC 47CFR Part15 Radio Frequency Device
 : Subpart E Unlicensed National Information Infrastructure Devices
 : Section 15.407 General technical requirements

*The revision on January 22, 2010 does not affect the test specification applied to the EUT.

The EUT complies with FCC Part 15 Subpart B: 2010, final revised on January 22, 2010 and effective March 1, 2010

3.2 Procedures & Results

Item	Test Procedure	Specification	Remarks	Deviation	Worst Margin	Results
Conducted Emission	ANSI C63.4:2003 7. AC powerline conducted emission measurements	15.407 (b)(6) and 15.207	-	N/A	5.0dB (15.31690MHz, AV, 11a Tx 5280MHz)	Complied
26dB Emission Bandwidth	ANSI C63.4:2003 13. Measurement of intentional radiators	FCC 15.407(a)(1)(2)	Conducted	N/A	See data	Complied
Maximum Peak Output Power	ANSI C63.4:2003 13. Measurement of intentional radiators	FCC 15.407 (a)(1)(2)	Conducted	N/A		Complied
Peak Power Spectral Density	ANSI C63.4:2003 13. Measurement of intentional radiators	FCC 15.407 (a)(1)(2)	Conducted	N/A		Complied
Peak Excursion Ratio	ANSI C63.4:2003 13. Measurement of intentional radiators	FCC 15.407 (a)(6)	Conducted	N/A		Complied
Out of Band Emission & Restricted Band Edges	ANSI C63.4:2003 13. Measurement of intentional radiators	15.407 (b)(1)(2)(4)(6) (7), 15.205 and 15.209	Conducted	N/A		Complied
Out of Band Emission & Restricted Band Edges	ANSI C63.4:2003 13. Measurement of intentional radiators	FCC 15.109, 15.407 (b)(1)(2)(5)(6) (7), 15.205 and 15.209	Radiated	N/A	0.2dB (8415.95MHz, Vertical, AV, 11a Tx 5260MHz)	Complied
Dynamic Frequency Selection	FCC 06-96 APPENDIX	FCC 15.407 (h)(2)	Conducted	*1)	N/A	N/A

Note: UL Japan's EMI Work Procedures No. QPM05 and No. QPM15.
 These tests were also referred to FCC Public Notice DA02-2138 "Measurement Procedure Updated for Peak Transmit Power in the Unlicensed National Information Infrastructure (U-NII) Bands".

*1) Refer to 30GE0098-YK-M, FCC part 15E (FCC15.407) DFS report.

UL Japan, Inc. Shonan EMC Lab.

1-22-3 Megumigaoka, Hiratsuka-shi, Kanagawa-ken, 259-1220 JAPAN

Telephone: +81 463 50 6400

Facsimile: +81 463 50 6401

3.3 Addition to standard

Item	Test Procedure	Specification	Remarks	Worst Margin	Results
Occupied bandwidth (99%)	ANSI C63.4:2003 13. Measurement of intentional radiators RSS-Gen 4.6.1	RSS-Gen 4.6.1	Conducted -		Complied

* Other than above, no addition, exclusion nor deviation has been made from the standard.

3.4 Uncertainty

The following uncertainties have been calculated to provide a confidence level of 95% using a coverage factor k=2.

Item	Frequency range	No.1 SAC ^{*1} /SR ^{*2} (±)	No.2 SAC/SR (±)	No.3 SAC/SR (±)
Conducted emission (AC Mains) AMN/LISN	150kHz-30MHz	3.0 dB	2.6 dB	3.1 dB
Radiated emission (Measurement distance: 3m)	30MHz-300MHz	4.6 dB	4.5 dB	4.9 dB
	300MHz-1GHz	4.5 dB	4.6 dB	5.1 dB
	1GHz-13GHz	3.9 dB	3.9 dB	4.0 dB
Radiated emission (Measurement distance: 1m)	13GHz-18GHz	4.8 dB	4.8 dB	4.8 dB
	18GHz-40GHz	4.2 dB	4.2 dB	4.2 dB

*1: SAC=Semi-Anechoic Chamber

*2: SR= Shielded Room is applied besides radiated emission

Conducted Emission Test

The data listed in this test report has enough margin, more than site margin.

Radiated Emission Test

The data listed in this report meets the limits unless the uncertainty is taken into consideration.

Conducted emissions, Power Density Measurement (below 1GHz) uncertainty for this test was: (±) 1.1dB

Conducted emissions, Power Density Measurement (1G-3GHz) uncertainty for this test was: (±) 1.2dB

Conducted emissions, Power Density Measurement (3G-18GHz) uncertainty for this test was: (±) 2.9dB

Conducted emissions Measurement (18G-26.5GHz) uncertainty for this test was: (±) 3.4dB

Conducted emissions Measurement (26.5G-50GHz) uncertainty for this test was: (±) 3.7dB

Power Measurement uncertainty above 1GHz for this test was: (±) 0.8dB

Bandwidth Measurement uncertainty for this test was: (±) 5.4%

UL Japan, Inc. Shonan EMC Lab.

1-22-3 Megumigaoka, Hiratsuka-shi, Kanagawa-ken, 259-1220 JAPAN

Telephone: +81 463 50 6400

Facsimile: +81 463 50 6401

3.5 Test location

UL Japan, Inc. Shonan EMC Lab.
1-22-3, Megumigaoka, Hiratsuka-shi, Kanagawa-ken 259-1220 JAPAN
Telephone number : +81 463 50 6400
Facsimile number : +81 463 50 6401

No.1/ No.2/ No.3 anechoic chamber has been fully described in a report submitted to FCC office, and accepted on April 17, 2009 (Registration No.: 697847).

IC Registration No. : 2973D-1 (No1 anechoic chamber)
2973D-2 (No2 anechoic chamber)
2973D-3 (No3 anechoic chamber)

Test room	Width x Depth x Height (m)	Test room	Width x Depth x Height (m)
No.1 Semi-anechoic chamber	20.6 x 11.3 x 7.65 Maximum measurement distance: 10m	No.1 Shielded room	6.8 x 4.1 x 2.7
No.2 Semi-anechoic chamber	20.6 x 11.3 x 7.65 Maximum measurement distance: 10m	No.2 Shielded room	6.8 x 4.1 x 2.7
No.3 Semi-anechoic chamber	12.7 x 7.7 x 5.35 Maximum measurement distance: 5m	No.3 Shielded room	6.3 x 4.7 x 2.7
No.4 Full-anechoic chamber	8.1 x 5.1 x 3.55	No.4 Shielded room	4.4 x 4.7 x 2.7
		No.5 Shielded room	7.8 x 6.4 x 2.7
		No.6 Shielded room	7.8 x 6.4 x 2.7

3.6 Test setup, Data of EMI & Test instruments

Refer to Appendix 1 to 3.

UL Japan, Inc.
Shonan EMC Lab.

1-22-3 Megumigaoka, Hiratsuka-shi, Kanagawa-ken, 259-1220 JAPAN

Telephone: +81 463 50 6400

Facsimile: +81 463 50 6401

4 System test configuration

4.1 Justification

The system was configured in typical fashion (as a customer would normally use it) for testing.

Mode	Remarks*
IEEE 802.11a (11a)	54Mbps, PN9
*The worst condition was determined based on the test result of Maximum Peak Output Power (Low Channel)	

Test Item	Operating Mode	Tested frequency
Conducted Emission	11a Tx	[Low Band]
26dB Bandwidth		5180MHz
Occupied Bandwidth (99%)		5200MHz
Maximum Peak Output Power		5240MHz
Peak Power Spectral Density		[Middle Band]
Peak Excursion Ratio		5260MHz
Out of Band Emissions		5280MHz
		5320MHz

UL Japan, Inc.

Shonan EMC Lab.

1-22-3 Megumigaoka, Hiratsuka-shi, Kanagawa-ken, 259-1220 JAPAN

Telephone: +81 463 50 6400

Facsimile: +81 463 50 6401

4.2 Configuration and peripherals

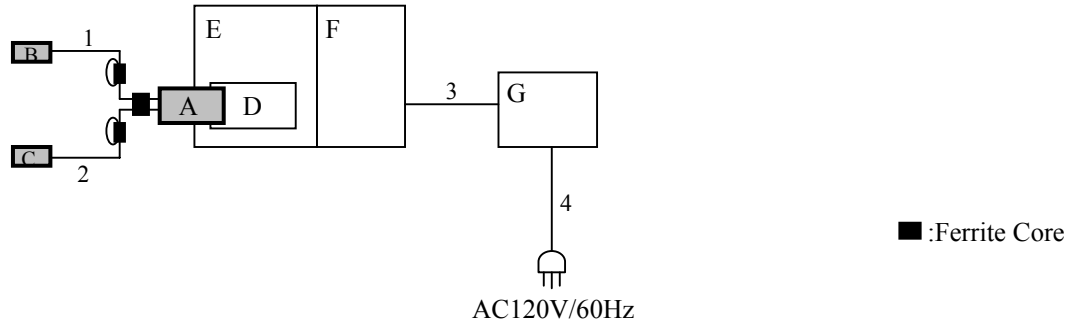

* Test data was taken under worst case conditions.

Description of EUT and support equipment

No.	Item	Model number	Serial number	Manufacturer	FCC ID (Remark)
A	Option(s) for Radiocommunications	R-WL54M1N	91290017	RICOH	BBP-WLRWL542 (EUT)
B	Antenna 1	ANT0602-	D3775683	NISSEI ELECTRIC	(EUT)
C	Antenna 2	WMFW/N-AB			
D	Extension board1	ABN105623	30590003	RICOH	(Jig)
E	Controller board	Type-DC1S	612S0038	RICOH	(Jig)
F	Extension board2	WBG226714	60690035	RICOH	(Jig)
G	PSU	MPT-400	2301219567	RICOH	(Jig)

List of cables used *1)

No.	Name	Length (m)	Shield		Remark
			Cable	Connector	
1	Antenna cable	1.0	Shielded	Shielded	(for antenna 1)
2	Antenna cable	1.0	Shielded	Shielded	(for antenna 2)
3	DC cable	0.7	Unshielded	Unshielded	-
4	AC cable	2.5	Unshielded	Unshielded	-

*1) All cables used for the measurement are exclusive use or marketed.

UL Japan, Inc.
Shonan EMC Lab.

1-22-3 Megumigaoka, Hiratsuka-shi, Kanagawa-ken, 259-1220 JAPAN

Telephone: +81 463 50 6400

Facsimile: +81 463 50 6401

5 Conducted emission

5.1 Operating environment

The test was carried out in No.1 shielded room.

Temperature : See test data
Humidity : See test data

5.2 Test configuration

EUT was placed on a platform of nominal size, 1m by 2m, raised 80cm above the conducting ground plane. The table is made of Styrofoam and covered with polyvinyl chloride. That has very low permittivity. The rear of tabletop was located 40cm to the vertical conducting plane. The rear of peripherals was aligned and flushed with rear of tabletop. All other surfaces of tabletop were at least 80cm from any other grounded conducting surface. EUT was located 80cm from a Line Impedance Stabilization Network (LISN) and excess AC cable was bundled in center. Photographs of the set up are shown in Appendix 1.

5.3 Test conditions

Frequency range : 0.15 - 30MHz
EUT position : Table top

5.4 Test procedure

The AC Mains Terminal Continuous disturbance Voltage had been measured with the EUT within a screened room. The EUT was connected to a Line Impedance Stabilization Network (LISN). An overview sweep with peak detection has been performed. The measurements had been performed with a quasi-peak detector and if required, an average detector. The conducted emission measurements were made with the following detector of the test receiver.

Detector Type : Quasi-Peak/ Average
IF Bandwidth : 9kHz

5.5 Results

Summary of the test results : Pass

Date : March 3, 2010

Test engineer : Tatsuya Arai

6 26dB Bandwidth & Occupied Bandwidth (99%)

Test Procedure

The bandwidth was measured with a spectrum analyzer connected to the antenna port.

Summary of the test results: Pass

Date : March 3, 2010

Test engineer : Tatsuya Arai

7 Maximum Peak Output Power

Test Procedure

The Maximum Peak Output Power was measured with a spectrum analyzer connected to the antenna port.

The test was made with the spectrum analyzer that has a function of channel-power measurement.

We followed the method 1 specified in DA-02-2138A1.

Summary of the test results: Pass

Date : February 18, 2010

Test engineer : Akio Hayashi

8 Peak Power Spectral Density

Test Procedure

The peak power spectral density was measured with a spectrum analyzer connected to the antenna port.

We followed the method 2 specified in DA-02-2138A1.

Summary of the test results: Pass

Date : March 3, 2010

Test engineer : Tatsuya Arai

9 Peak Excursion Ratio

Test Procedure

The Peak Excursion Ratio was measured with a spectrum analyzer connected to the antenna port.

The second sweep was measured based on method 1 specified in DA-02-2138A1

Summary of the test results: Pass

Date : March 3, 2010

Test engineer : Tatsuya Arai

10 Out of Band Emissions (Antenna Port Conducted)

Test Procedure

The Out of Band Emissions was measured with a spectrum analyzer connected to the antenna port.

Summary of the test results: Pass

Date : March 3, 2010

Test engineer : Tatsuya Arai

UL Japan, Inc.

Shonan EMC Lab.

1-22-3 Megumigaoka, Hiratsuka-shi, Kanagawa-ken, 259-1220 JAPAN

Telephone: +81 463 50 6400

Facsimile: +81 463 50 6401

11 Out of band emissions (Radiated)

11.1 Operating environment

The test was carried out in No.3 Semi-anechoic chamber.

11.2 Test configuration

EUT was placed on a urethane platform of nominal size, 0.5m by 0.5m, raised 80cm above the conducting ground plane. Photographs of the set up are shown in Appendix 1.

11.3 Test conditions

Frequency range : 30MHz - 40GHz

11.4 Test procedure

The Radiated Electric Field Strength intensity has been measured with a ground plane and at a distance of 3m(below 13GHz) and 1m(above13GHz).

The measuring antenna height was varied between 1 and 4m and EUT was rotated a full revolution in order to obtain the maximum value of the electric field intensity.

The measurements were performed for both vertical and horizontal antenna polarization.

Measurements were performed with QP, PK, and AV detector.

The radiated emission measurements were made with the following detector function of the test receiver.

Frequency	Below 1GHz	Above 1GHz
Instrument used	Test Receiver	Spectrum Analyzer *1)
Detector IF Bandwidth	QP: BW 120kHz	PK: RBW: 1MHz/VBW: 1MHz, AV RBW: 1MHz VBW: 10Hz (No pulse emission detected)
Measuring antenna	Biconical (30-300MHz) Logperiodic (300MHz-1GHz)	Horn
Test distance	3m	3m(below 13GHz) 1m(above 13GHz)

*1) When using Spectrum analyzer, the test was made with adjusting span to zero by using peak hold.

The equipment was previously checked at each position of three axes X, Y and Z. The position in which the maximum noise occurred was chosen to put into measurement. See the photographs in appendix.

11.5 Band edge

Band edge level at 5150MHz and 5350MHz is below the limits of FCC 15.209. Refer to the data of Radiated emission.

11.6 Results

Summary of the test results : Pass *No noise was detected above the 5th order harmonics.

Date : February 25-27, March 1, and 2, 2010 Test engineer : Akio Hayashi and Makoto Hosaka

APPENDIX 1: Photographs of test setup

Page 13	:	Conducted emission
Page 14	:	Out of band emissions
Page 15 - 16	:	Pre-check of the worst position

APPENDIX 2: Test data

Page 17 - 22	:	Conducted Emission
Page 23 - 24	:	26dB bandwidth
Page 25	:	99% Occupied Bandwidth
Page 26 - 29	:	Peak Output Power
Page 30 - 41	:	Out of band emissions (Radiated)
Page 42 - 54	:	Out of band emissions (Antenna port conducted)
Page 55 - 56	:	Peak power density
Page 57 - 58	:	Peak Excursion Ratio

APPENDIX 3: Test instruments

Page 59	:	Test instruments
---------	---	------------------