



RADIO TEST REPORT

Test Report No. : 27IE0337-YK-A

Applicant : RICOH COMPANY, LTD.
Type of Equipment : Option(s) for Radiocommunications
Model No. : R-WL54MN
FCC ID : BBP-WLRWL541
Test Standard : FCC Part15 Subpart C: 2007
: FCC Part15 Subpart B: 2007
Test Result : Complied

1. This test report shall not be reproduced except in full or partial, without the written approval of UL Japan, Inc.
2. The results in this report apply only to the sample tested.
3. This sample tested is in compliance with the limits of the above regulation.
4. The test results in this test report are traceable to the national or international standards.

Date of test: May 14, 15, 16, 17 and 22, 2007

Tested by: T. Imamura & T. Suzuki
Toyokazu Imamura & Takahiro Suzuki

T. Arai
Tatsuya Arai

Approved by: O. Watatani
Osamu Watatani
Manager of Yamakita EMC Lab.

UL Japan, Inc.

YAMAKITA EMC LAB.

907 Kawanishi, Yamakita-machi, Ashigarakami-gun, Kanagawa-ken, 258-0124 JAPAN

Telephone: +81 465 77 1011 Facsimile: +81 465 77 2112

MF060b (18.06.07)

Table of Contents	Page
1 Applicant Information	3
2 Equipment under test (E.U.T.)	3
3 Test Specification, Procedures and Results	4
4 System Test Configuration	6
5 Conducted emission	8
6 6dB Bandwidth & Occupied Bandwidth (99%)	8
7 Maximum Peak Output Power	8
8 Out of Band Emissions (Antenna Port Conducted)	8
9 Out of Band Emissions (Radiated)	9
10 Peak Power Density	10
<u>Contents of Appendixes</u>	11
APPENDIX 1: Photographs of test setup	12
APPENDIX 2: Test Data	15
APPENDIX 3: Test instruments	69

UL Japan, Inc.

YAMAKITA EMC LAB.

907 Kawanishi, Yamakita-machi, Ashigarakami-gun, Kanagawa-ken, 258-0124 JAPAN

Telephone: +81 465 77 1011 Facsimile: +81 465 77 2112

MF060b (18.06.07)

1 Applicant Information

Company Name : RICOH COMPANY, LTD.
Address : 810 Shimoimaizumi, Ebina-shi, Kanagawa-ken, 243-0460 Japan
Telephone Number : +81-46-292-6870
Facsimile Number : +81-46-231-9183
Contact Person : Shinji Okada

2 Equipment under test (E.U.T.)

2.1 Identification of E.U.T.

Type of Equipment : Option(s) for Radiocommunications
Model No. : R-WL54MN
Serial No. : 704S0191
Rating : DC3.3V
Country of Manufacture : Japan
Receipt Date of Sample : May 9, 2007
Condition of EUT : Production prototype
(Not for Sale: This sample is equivalent to mass-produced items.)

2.2 Product Description

Model: R-WL54MN (referred to as the EUT in this report) is Option(s) for Radiocommunications.

Equipment type : Transceiver
Frequency of operation : [11b/g] 2412-2462MHz
[11a] 5180-5320MHz *1)
Clock frequency : 11MHz, 20MHz
Bandwidth & channel spacing : [11b/g] 22MHz & 5MHz
[11a] 18MHz & 20MHz
Type of modulation : IEEE802.11a: OFDM (BPSK, QPSK, 16QAM, 64QAM)
IEEE802.11b: DSSS (DBPSK, DQPSK, CCK)
IEEE802.11g: OFDM (BPSK, QPSK, 16QAM, 64QAM)
Antenna type : Monopole
Antenna 1: Transmitting & Receiving
Antenna 2: Receiving only
Antenna connector type : None
Antenna gain : [11b/g] max +3dBi
[11a] max +4dBi
ITU code : D1D, G1D
Operation temperature range : 0 ~ +65 deg.C.

*1) Refer to 27IE0337-YK-B, FCC part 15E (FCC 15.407) report.

FCC 15.31 (e)

The RICOH product provides stable voltage (DC3.3V) constantly to the EUT (RF Module) regardless of input voltage. Therefore, the EUT complies with the requirement.

FCC Part 15.203

The antenna is not removable from the EUT. Therefore, the equipment complies with the antenna requirement of Section 15.203.

UL Japan, Inc.

YAMAKITA EMC LAB.

907 Kawanishi, Yamakita-machi, Ashigarakami-gun, Kanagawa-ken, 258-0124 JAPAN

Telephone: +81 465 77 1011 Facsimile: +81 465 77 2112

MF060b (18.06.07)

3 Test Specification, Procedures and Results

3.1 Test specification

Test Specification : FCC Part 15 Subpart B: 2007
 Title : FCC 47CFR Part 15 Radio Frequency Device
 Subpart B Unintentional Radiators
 Test specification : FCC Part15 Subpart C: 2007
 Title : FCC 47CFR Part15 Radio Frequency Device Subpart C Intentional Radiators
 Section 15.207 Conducted limits
 Section 15.209 Radiated emission limits, general requirements
 Section 15.247 Operation within the bands 902-928MHz, 2400-2483.5MHz,
 and 5725-5850MHz

3.2 Procedures & Results

Item	Test Procedure	Specification	Remarks	Deviation	Worst Margin	Results
Conducted Emission	ANSI C63.4:2003 7. AC powerline conducted emission measurements	FCC 15.107(a) & 207	-	N/A	21.8dB (0.2647MHz, Tx 2412MHz, QP, IEEE802.11b (11Mbps))	Complied
6dB Bandwidth	ANSI C63.4:2003 13. Measurement of intentional radiators	FCC 15.247 (a)(2) & 15.209	Conducted	N/A	-	Complied
Maximum Peak Output Power	ANSI C63.4:2003 13. Measurement of intentional radiators	FCC 15.247 (b)(3) & 15.209	Conducted	N/A	-	Complied
Out of Band Emission & Restricted Band Edges	ANSI C63.4:2003 13. Measurement of intentional radiators	FCC 15.109, 15.247 (d) & 15.209	Conducted / Radiated	N/A	Tx: 2.5dB (156.57MHz, Horizontal, Tx 2462MHz, IEEE802.11b (11Mbps)) Rx: 2.2dB (148.60MHz, Horizontal, Rx 2437MHz)	Complied
Power Density	ANSI C63.4:2003 13. Measurement of intentional radiators	FCC 15.247 (e) & 15.209	Conducted	N/A	-	Complied
Antenna power conduction for receivers	ANSI C63.4: 2003 12.1.5 Antenna-conducted power measurements	FCC 15.111 (a)	-	N/A *1)	-	N/A

*1) The test is not applicable since the EUT does not tune in the frequency range 30 to 960MHz.

Note: UL Japan's EMI Work Procedures No.QPM05.

These tests were also referred to "Guidance on Measurement for Digital Transmission Systems Section15.247".

* Other than mentioned in 3.3, no addition, exclusion nor deviation has been made from the standard.

3.3 Addition to standard

Item	Test Procedure	Specification	Remarks	Worst Margin	Results
Occupied Bandwidth (99%)	ANSI C63.4:2003 13. Measurement of intentional radiators RSS-Gen 4.4.1	RSS-Gen 4.4.1	Conducted	-	Complied

UL Japan, Inc.

YAMAKITA EMC LAB.

907 Kawanishi, Yamakita-machi, Ashigarakami-gun, Kanagawa-ken, 258-0124 JAPAN

Telephone: +81 465 77 1011 Facsimile: +81 465 77 2112

MF060b (18.06.07)

3.4 Uncertainty

The following uncertainties have been calculated to provide a confidence level of 95% using a coverage factor k=2.

	No.1 open site	No.2 open site	No.1 anechoic chamber
Conducted emission			
150kHz-30MHz	2.8 dB	2.8 dB	2.8 dB
Radiated emission (3m)			
30-300MHz	4.5 dB	4.4 dB	4.5 dB
300-1000MHz	4.3 dB	4.3 dB	4.3 dB
1GHz<	5.7 dB	5.7 dB	5.7 dB

Antenna port conducted test	
Below 1GHz	±0.4dB
1GHz and above	±0.7dB

Conducted Emission Test

The data listed in this test report has enough margin, more than site margin.

Radiated Emission Test

The data listed in this report meets the limits unless the uncertainty is taken into consideration.

3.5 Test Location

UL Japan, Inc. Yamakita EMC Lab.

907, Kawanishi, Yamakita-machi, Ashigarakami-gun, Kanagawa-ken 258-0124 JAPAN

Telephone number : +81 465 77 1011

Facsimile number : +81 465 77 2112

NVLAP Lab. code : 200441-0

No. 1 test site has been fully described in a report submitted to FCC office, and accepted on August 26, 2005 (Registration No.: 95486).

IC Registration No. : 2973B-1

No. 2 test site has been fully described in a report submitted to FCC office, and accepted on April 4, 2005 (Registration No.: 466226).

IC Registration No. : 2973B-3

No. 1 anechoic chamber has been fully described in a report submitted to FCC office, and accepted on November 2, 2005 (Registration No.: 95967).

IC Registration No. : 2973B-2

Test room	Width x Depth x Height (m)	Test room	Width x Depth x Height (m)
No.1 shielded room	8.0 x 5.0 x 2.5	No.1 Semi-anechoic chamber	10.0 x 7.5 x 5.7
No.2 shielded room	5.0 x 4.0 x 2.5		
No.3 shielded room	4.0 x 5.0 x 2.7		

UL Japan, Inc.

YAMAKITA EMC LAB.

907 Kawanishi, Yamakita-machi, Ashigarakami-gun, Kanagawa-ken, 258-0124 JAPAN

Telephone: +81 465 77 1011 Facsimile: +81 465 77 2112

MF060b (18.06.07)

4 System Test Configuration

4.1 Justification

The system was configured in typical fashion (as a customer would normally use it) for testing.

Transmitting (IEEE802.11b (11Mbps))	-2412MHz (Low)
	-2437MHz (Middle)
	-2462MHz (High)
Transmitting (IEEE802.11g (54Mbps))	-2412MHz (Low)
	-2437MHz (Middle)
	-2462MHz (High)
Receiving (IEEE802.11g (54Mbps))	-2437MHz (Middle)

The EUT has an ability to provide some different modulation and data rates. Some of these modulation and data rates did not change in the spectrum envelopes of the EUT at conducted measurement with the antenna terminal. Therefore, the results of the final measurements were the IEEE 802.11b DSSS (CCK, 11Mbps) and IEEE 802.11g OFDM (64QAM, 54Mbps) modulation as the highest data rate.

UL Japan, Inc.

YAMAKITA EMC LAB.

907 Kawanishi, Yamakita-machi, Ashigarakami-gun, Kanagawa-ken, 258-0124 JAPAN

Telephone: +81 465 77 1011 Facsimile: +81 465 77 2112

MF060b (18.06.07)

4.2 Configuration of Tested System

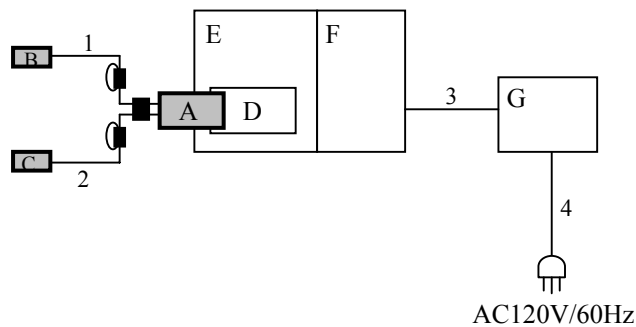

* Test data was taken under worst case conditions.

Description of EUT and support equipment

No.	Item	Model number	Serial number	Manufacturer	FCC ID (Remark)
A	Option(s) for Radiocommunications	R-WL54MN	704S0191	RICOH	BBP-WLRWL541 (EUT)
B	Antenna 1	ANT0602-	D3775683	NISSEI ELECTRIC	(EUT)
C	Antenna 2	WMFW/N-AB			
D	Extension board1	ABN105623		RICOH	(Jig)
E	Controller board	Type-DC	D0095742	RICOH	(Jig)
F	Extension board2	WBG226714	-	RICOH	(Jig)
G	PSU	MPT-400	2301218427	RICOH	(Jig)

List of cables used *1)

No.	Name	Length (m)	Shield		Remark
			Cable	Connector	
1	Antenna cable	0.9	Shielded	Shielded	(for antenna 1)
2	Antenna cable	0.9	Shielded	Shielded	(for antenna 2)
3	DC cable	0.7	Unshielded	Unshielded	-
4	AC cable	1.5	Unshielded	Unshielded	-

*1) All cables used for the measurement are exclusive use or marketed.

UL Japan, Inc.

YAMAKITA EMC LAB.

907 Kawanishi, Yamakita-machi, Ashigarakami-gun, Kanagawa-ken, 258-0124 JAPAN

Telephone: +81 465 77 1011

Facsimile: +81 465 77 2112

MF060b (18.06.07)

5 Conducted Emissions

5.1 Operating environment

The test was carried out in No.2 shielded room.

5.2 Test configuration

EUT was placed on a platform of nominal size, 1m by 1.8m, raised 80cm above the conducting ground plane. The rear of tabletop was located 40cm to the vertical conducting plane. The rear of peripherals was aligned and flushed with rear of tabletop. All other surfaces of tabletop were at least 80cm from any other grounded conducting surface. EUT was located 80cm from a Line Impedance Stabilization Network (LISN) and excess AC cable was bundled in center. A drawing of the set up is shown in the photos of Appendix 1.

5.3 Test conditions

Frequency range : 0.15 - 30MHz
EUT operation mode : Transmitting, Receiving

5.4 Test procedure

The PSU was connected to a LISN (AMN). An overview sweep with peak detection has been performed. The Conducted emission measurements were made with the following detector function of the test receiver.

Detector: QP/AV
IF Bandwidth: 9kHz

5.5 Results

Summary of the test results : Pass
Date : May 17, 2007 Test engineer : Takahiro Suzuki

6 6dB Bandwidth & Occupied Bandwidth (99%)

Test Procedure

The bandwidth was measured with a spectrum analyzer connected to the antenna port.

Summary of the test results: Pass
Date: May 22, 2007 Test engineer : Tatsuya Arai

7 Maximum Peak Output Power

Test Procedure

The Maximum Peak Output Power was measured with a power meter connected to the antenna port.

Summary of the test results: Pass
Date: May 22, 2007 Test engineer : Tatsuya Arai

8 Out of Band Emissions (Antenna Port Conducted)

Test Procedure

The Out of Band Emissions was measured with a spectrum analyzer connected to the antenna port.

Summary of the test results: Pass
Date: May 22, 2007 Test engineer : Tatsuya Arai

UL Japan, Inc.

YAMAKITA EMC LAB.

907 Kawanishi, Yamakita-machi, Ashigarakami-gun, Kanagawa-ken, 258-0124 JAPAN

Telephone: +81 465 77 1011 Facsimile: +81 465 77 2112

MF060b (18.06.07)

9 Out of Band Emissions (Radiated)

9.1 Operating environment

The test was carried out in No.1 anechoic chamber.

9.2 Test configuration

EUT was placed on a urethane platform of nominal size, 0.5m by 0.5m, raised 80cm above the conducting ground plane. A drawing of the set up is shown in the photos of Appendix 1.

9.3 Test conditions

Frequency range : 30MHz - 26.5GHz
 Test distance : 3m
 EUT operation mode : Transmitting, Receiving

9.4 Test procedure

The Radiated Electric Field Strength intensity has been measured with a ground plane and at a distance of 3m. The measuring antenna height was varied between 1 and 4m and EUT was rotated a full revolution in order to obtain the maximum value of the electric field intensity.

The measurements were performed for both vertical and horizontal antenna polarization.

In any 100kHz bandwidth outside the frequency band in which the spread spectrum intentional radiator is operating, the radio frequency power that is produced by the intentional radiator confirmed 20dB below that in the 100kHz bandwidth within the band that contains the highest level of the desired power, based on a radiated measurement.

Measurements were performed with QP, PK, and AV detector.

The radiated emission measurements were made with the following detector function of the test receiver.

When using Spectrum analyzer, the test was made with adjusting span to zero by using peak hold.

Frequency	Below 1GHz	Above 1GHz
Instrument used	Test Receiver	Spectrum Analyzer
Detector IF Bandwidth	QP: BW 120kHz	PK: RBW: 1MHz/VBW: 1MHz, AV: RBW: 1MHz/VBW: 10Hz
Measuring antenna	Biconical (30-300MHz) Logperiodic (300MHz-1GHz)	Horn

The equipment and its antenna were previously checked at each position of three axes X, Y and Z. The position in which the maximum noise occurred was chosen to put into measurement. See the table below and photographs in page 14. With the position, the noise levels of all the frequencies were measured.

Model	Worst position	
	Below 1GHz	Above 1GHz
Module	Horizontal: X, Vertical: X	Horizontal: X, Vertical: X
Antenna	Horizontal: Z, Vertical: Z	Horizontal: X, Vertical: Y

9.5 Band edge

Band edge level at 2400MHz is less than 20dB of peak point of the carrier. Refer to the data of Out of Band Emissions (Antenna Port Conducted).

Band edge level at 2390MHz and 2483.5MHz is below the limits of FCC 15.209. Refer to the data of Radiated emission.

9.6 Results

Summary of the test results : Pass
 No noise was detected above the 5th order harmonics.

Date: May 14, 15, 16 and 17, 2007

Test engineer : Toyokazu Imamura and Takahiro Suzuki

UL Japan, Inc.

YAMAKITA EMC LAB.

907 Kawanishi, Yamakita-machi, Ashigarakami-gun, Kanagawa-ken, 258-0124 JAPAN

Telephone: +81 465 77 1011 Facsimile: +81 465 77 2112

MF060b (18.06.07)

10 Peak Power Density

Test Procedure

The peak power density was measured with a spectrum analyzer connected to the antenna port.

Summary of the test results: Pass

Date: May 22, 2007

Test engineer : Tatsuya Arai

UL Japan, Inc.

YAMAKITA EMC LAB.

907 Kawanishi, Yamakita-machi, Ashigarakami-gun, Kanagawa-ken, 258-0124 JAPAN

Telephone: +81 465 77 1011

Facsimile: +81 465 77 2112

MF060b (18.06.07)

APPENDIX 1: Photographs of test setup

Page 12	:	Conducted emission
Page 13	:	Radiated emission
Page 14	:	Pre check of worse-case position

APPENDIX 2: Test Data

Page 15 - 25	:	Conducted emission
Page 26 - 27	:	6dB Bandwidth
Page 28	:	Maximum Peak Output Power
Page 29 - 42	:	Out of Band Emissions (Antenna Port Conducted)
Page 43 - 63	:	Out of Band Emissions (Radiated)
Page 64 - 66	:	Peak Power Density
Page 67 - 68	:	Occupied Bandwidth

APPENDIX 3: Test instruments

Page 69	:	Test instruments
---------	---	------------------

UL Japan, Inc.

YAMAKITA EMC LAB.

907 Kawanishi, Yamakita-machi, Ashigarakami-gun, Kanagawa-ken, 258-0124 JAPAN

Telephone: +81 465 77 1011 Facsimile: +81 465 77 2112

MF060b (18.06.07)

DATA OF CONDUCTION TEST

UL Japan, Inc.
YAMAKITA No.2 SHIELD ROOM
Report No. : 271E0337-YK-A

Applicant : RICOH COMPANY, LTD.
Kind of Equipment : Option(s) for Radiocommunications
Model No. : R-WL54MN
Serial No. : 704S0191
Power : AC120V/60Hz
Mode : Transmitting (2412MHz)
Remarks : IEEE802.11b
Date : 5/17/2007
Phase : Single Phase
Temperature : 22 °C Engineer : Takahiro Suzuki
Humidity : 57 %
Regulation : FCC Part15C § 15.207. (CISPR Pub.22)

No.	FREQ. [MHz]	READING(N)		READING(L1)		LISN FACTOR [dB]	CABLE LOSS [dB]	ATTEN. [dB]	RESULT		LIMITS		MARGIN	
		QP [dB μV]	AV	QP [dB μV]	AV				QP [dB]	AV [dB μV]	QP [dB μV]	AV [dB μV]	QP [dB]	AV
1.	0.1556	36.6	-	37.1	-	0.1	0.1	0.0	37.3	-	65.7	55.7	28.4	-
2.	0.1816	37.7	-	39.9	-	0.1	0.1	0.0	40.1	-	64.4	54.4	24.3	-
3.	0.2647	39.3	-	35.7	-	0.1	0.1	0.0	39.5	-	61.3	51.3	21.8	-
4.	0.3112	35.4	-	33.3	-	0.1	0.1	0.0	35.6	-	59.9	49.9	24.3	-
5.	17.0790	26.9	-	27.6	-	0.4	0.6	0.0	28.6	-	60.0	50.0	31.4	-
6.	26.2510	28.7	-	29.2	-	0.6	0.8	0.0	30.6	-	60.0	50.0	29.4	-

CALCULATION: READING + LISN FACTOR + CABLE LOSS + ATTEN.

■ LISN :KLS-02 (NSLK8127) ■ COAXIAL CABLE :KCC-33/34
■ EMI RECEIVER :KTR-01 (ES140)

DATA OF CONDUCTION TEST

UL Japan, Inc.
YAMAKITA No.2 SHIELD ROOM
Report No. : 271E0337-YK-A

Applicant : RICOH COMPANY, LTD.
Kind of Equipment : Option(s) for Radiocommunications
Model No. : R-WL54MN
Serial No. : 704S0191
Power : AC120V/60Hz
Mode : Transmitting (2412MHz)
Remarks : IEEE802.11b
Date : 5/17/2007
Phase : Single Phase
Temperature : 22 °C Engineer : Takahiro Suzuki
Humidity : 57 %
Regulation : FCC Part15C § 15.207. (CISPR Pub.22)

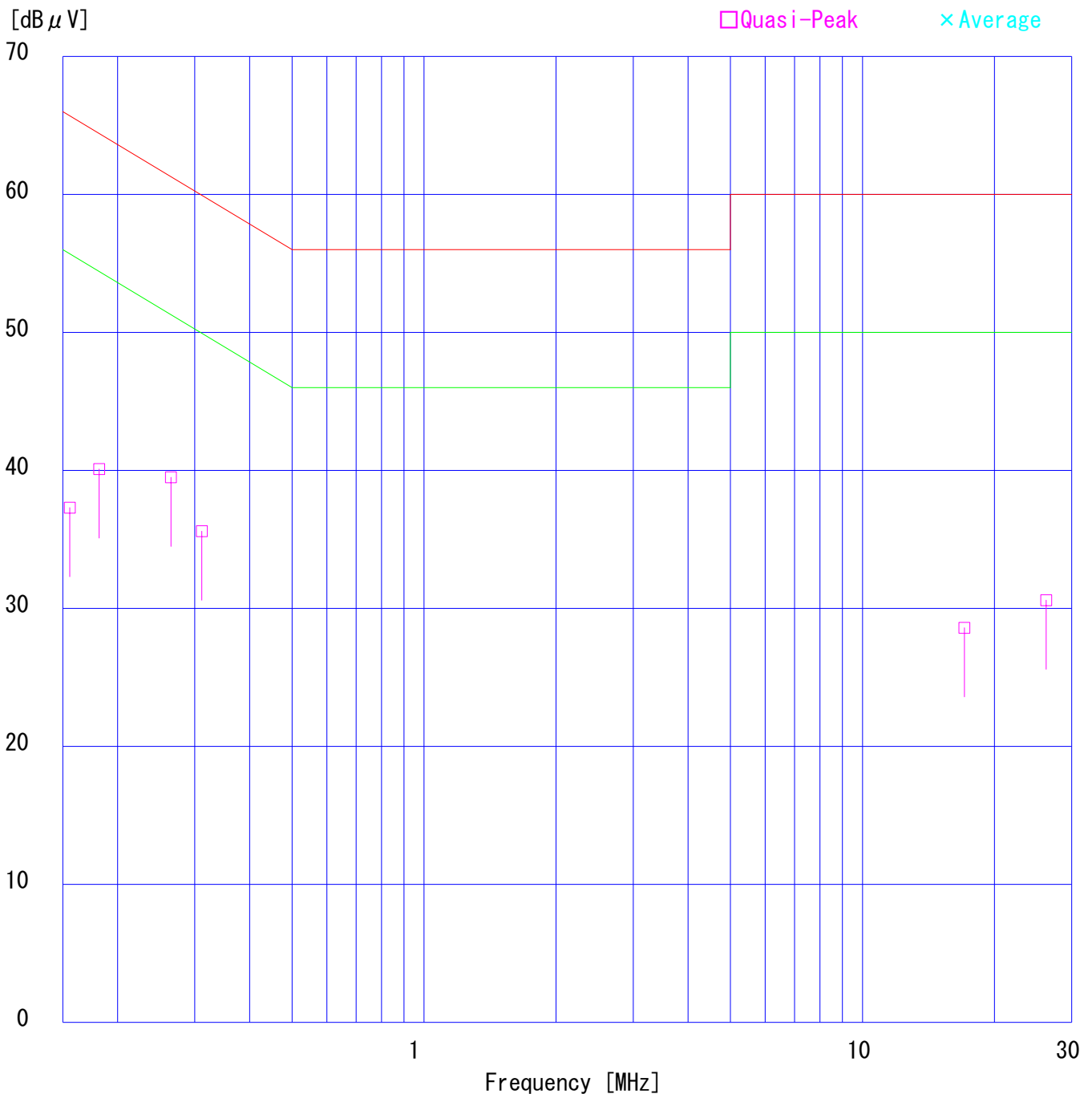

DATA OF CONDUCTION TEST CHART

UL Japan, Inc.
YAMAKITA No.2 SHIELD ROOM
Report No. : 271E0337-YK-A

Applicant : RICOH COMPANY, LTD.
Kind of Equipment : Option(s) for Radiocommunications
Model No. : R-WL54MN
Serial No. : 704S0191
Power : AC120V/60Hz
Mode : Transmitting (2412MHz)
Remarks : IEEE802.11b
Date : 5/17/2007
Phase : Single Phase
Temperature : 22 °C
Humidity : 57 %
Regulation 1 : FCC Part15C § 15.207. (CISPR Pub.22)
Regulation 2 : None

Engineer : Takahiro Suzuki

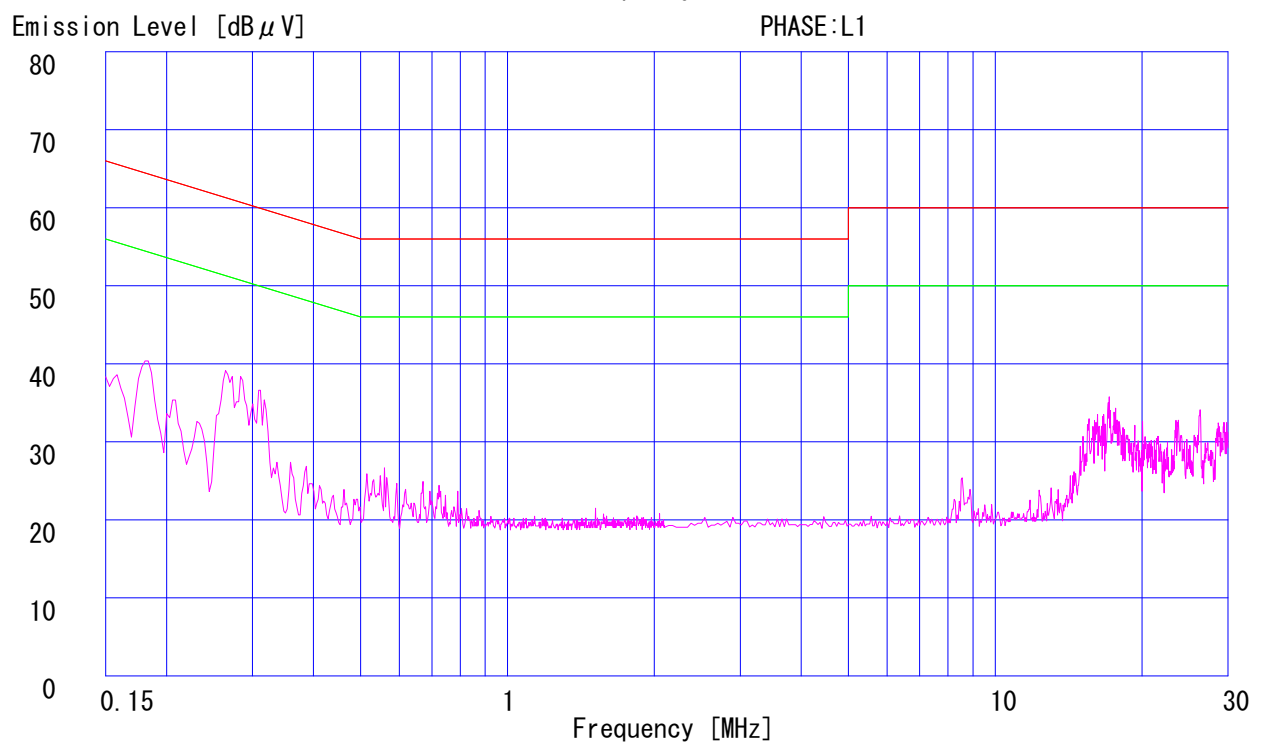
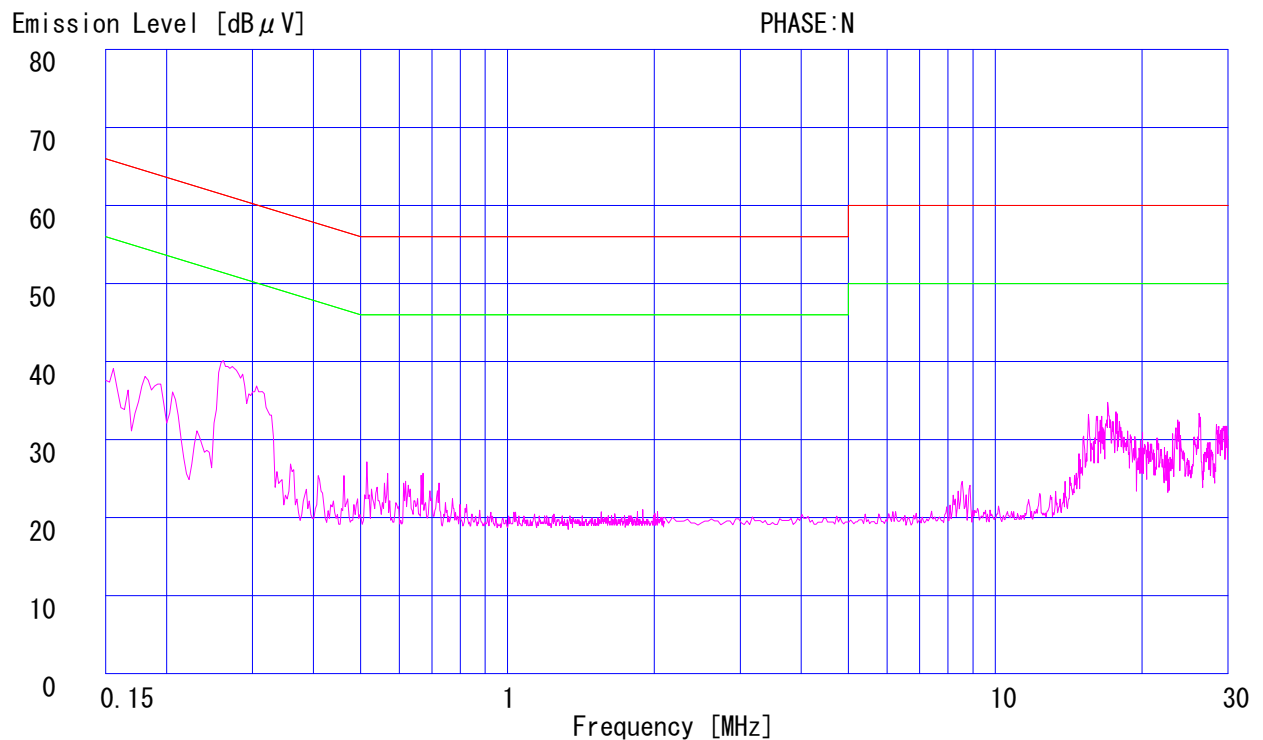

DATA OF CONDUCTION TEST CHART

UL Japan, Inc.
YAMAKITA No.2 SHIELD ROOM
Report No. : 271E0337-YK-A

Applicant : RICOH COMPANY, LTD.
Kind of Equipment : Option(s) for Radiocommunications
Model No. : R-WL54MN
Serial No. : 704S0191
Power : AC120V/60Hz
Mode : Transmitting (2437MHz)
Remarks : IEEE802.11b
Date : 5/17/2007
Phase : Single Phase
Temperature : 22 °C
Humidity : 57 %
Regulation 1 : FCC Part15C § 15.207. (CISPR Pub.22)
Regulation 2 : None

Engineer : Takahiro Suzuki

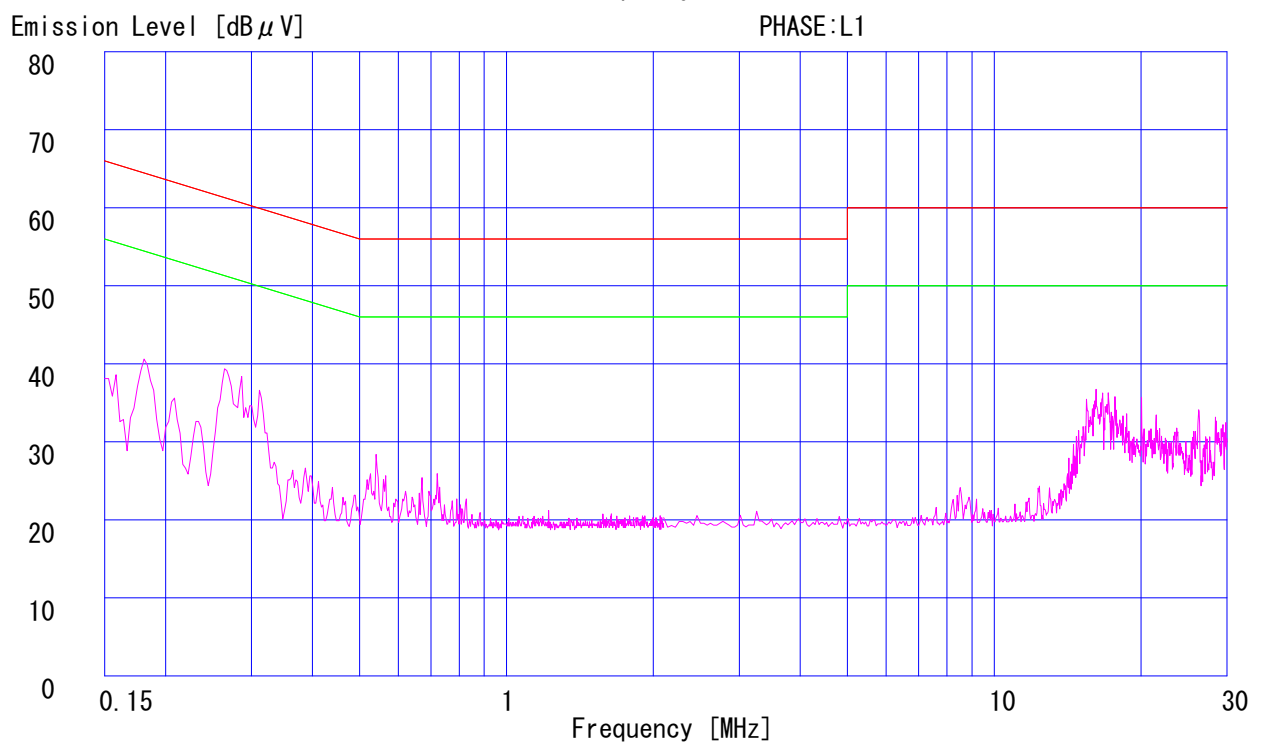
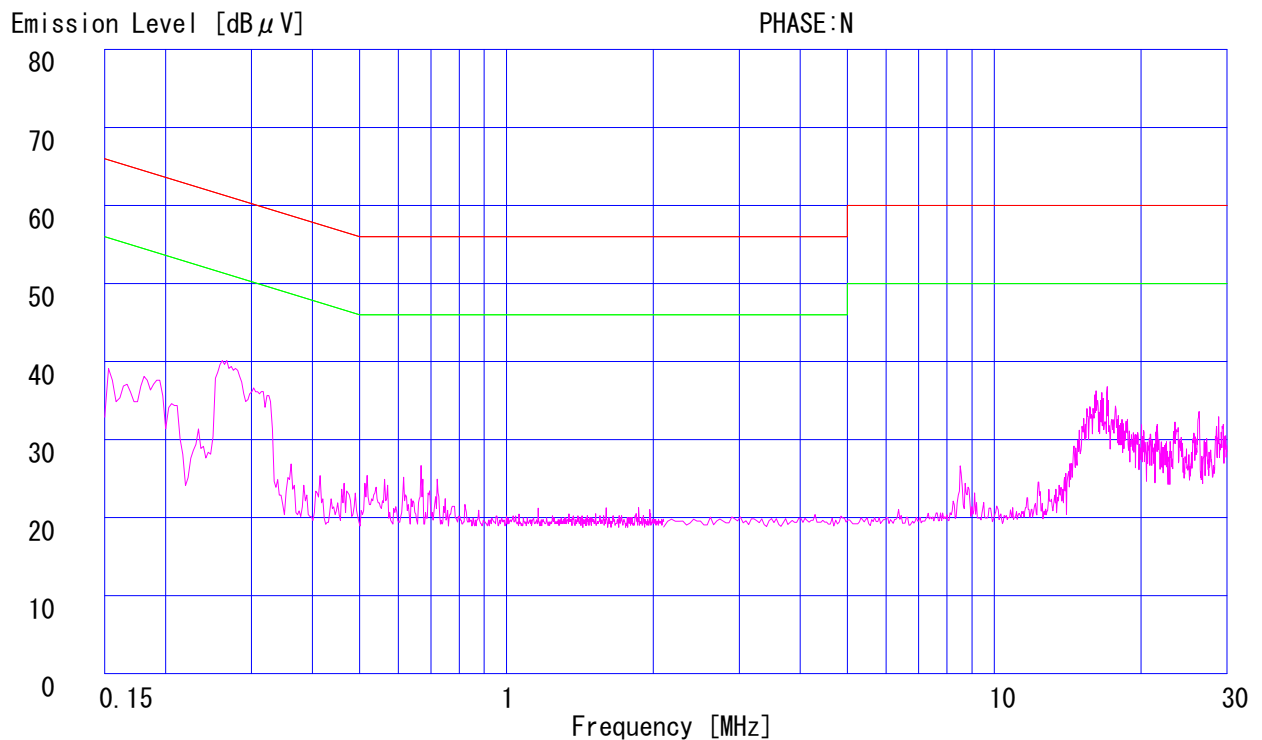

DATA OF CONDUCTION TEST CHART

UL Japan, Inc.
YAMAKITA No.2 SHIELD ROOM
Report No. : 271E0337-YK-A

Applicant : RICOH COMPANY, LTD.
Kind of Equipment : Option(s) for Radiocommunications
Model No. : R-WL54MN
Serial No. : 704S0191
Power : AC120V/60Hz
Mode : Transmitting (2462MHz)
Remarks : IEEE802.11b
Date : 5/17/2007
Phase : Single Phase
Temperature : 22 °C
Humidity : 57 %
Regulation 1 : FCC Part15C § 15.207. (CISPR Pub.22)
Regulation 2 : None

Engineer : Takahiro Suzuki

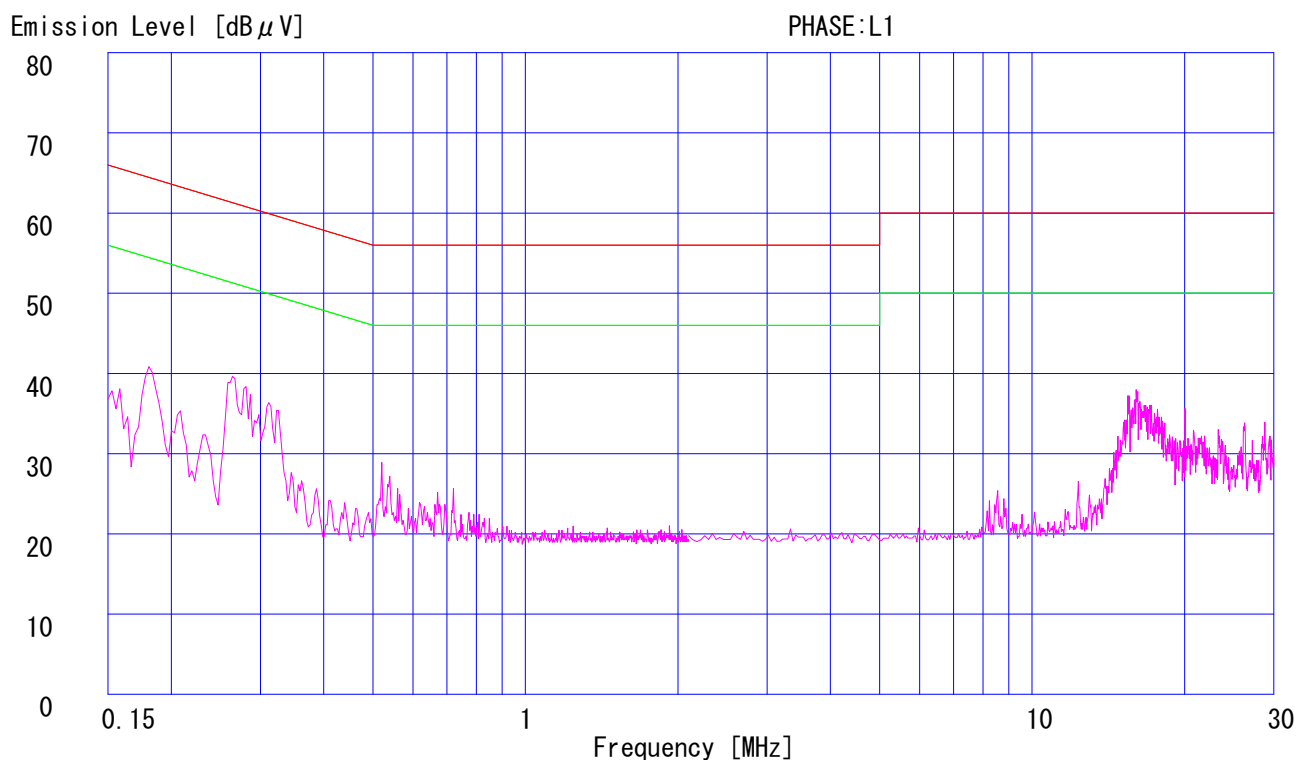
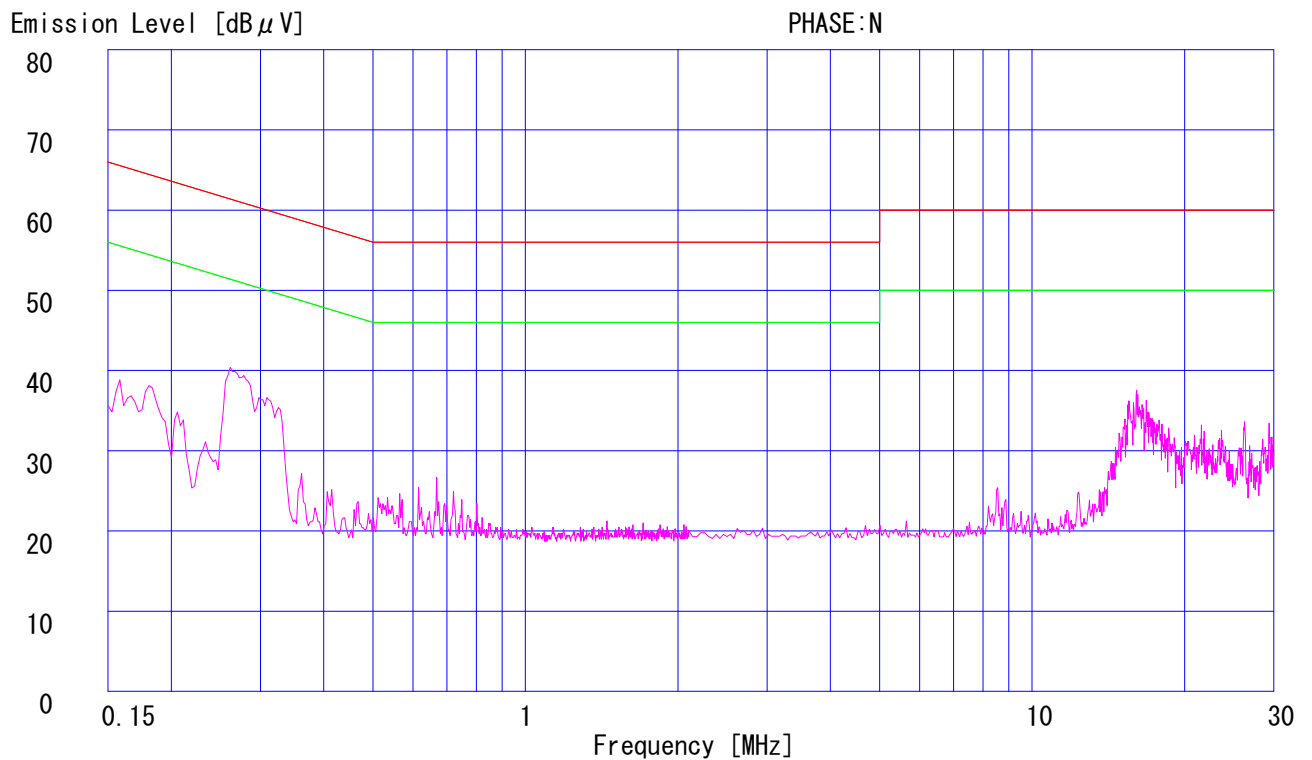

DATA OF CONDUCTION TEST

UL Japan, Inc.
YAMAKITA No.2 SHIELD ROOM
Report No. : 271E0337-YK-A

Applicant : RICOH COMPANY, LTD.
 Kind of Equipment : Option(s) for Radiocommunications
 Model No. : R-WL54MN
 Serial No. : 704S0191
 Power : AC120V/60Hz
 Mode : Transmitting (2412MHz)
 Remarks : IEEE802.11g
 Date : 5/17/2007
 Phase : Single Phase
 Temperature : 22 °C Engineer : Takahiro Suzuki
 Humidity : 57 %
 Regulation : FCC Part15C § 15.207. (CISPR Pub.22)

No.	FREQ. [MHz]	READING(N)		READING(L1)		LISN FACTOR [dB]	CABLE LOSS [dB]	ATTEN. [dB]	RESULT		LIMITS		MARGIN	
		QP [dB μ V]	AV	QP [dB μ V]	AV				QP [dB]	AV [dB μ V]	QP [dB μ V]	AV [dB μ V]	QP [dB]	AV [dB]
1.	0.1560	36.4	-	36.4	-	0.1	0.1	0.0	36.6	-	65.7	55.7	29.1	-
2.	0.1819	37.1	-	39.4	-	0.1	0.1	0.0	39.6	-	64.4	54.4	24.8	-
3.	0.2729	37.9	-	33.9	-	0.1	0.1	0.0	38.1	-	61.0	51.0	22.9	-
4.	0.3127	35.3	-	33.0	-	0.1	0.1	0.0	35.5	-	59.9	49.9	24.4	-
5.	16.0570	27.9	-	31.3	-	0.4	0.6	0.0	32.3	-	60.0	50.0	27.7	-
6.	26.2370	27.8	-	28.6	-	0.6	0.8	0.0	30.0	-	60.0	50.0	30.0	-

CALCULATION: READING + LISN FACTOR + CABLE LOSS + ATTEN.

■ LISN :KLS-02 (NSLK8127) ■ COAXIAL CABLE :KCC-33/34
 ■ EMI RECEIVER :KTR-01 (ES140)

DATA OF CONDUCTION TEST

UL Japan, Inc.
YAMAKITA No.2 SHIELD ROOM
Report No. : 271E0337-YK-A

Applicant : RICOH COMPANY, LTD.
Kind of Equipment : Option(s) for Radiocommunications
Model No. : R-WL54MN
Serial No. : 704S0191
Power : AC120V/60Hz
Mode : Transmitting (2412MHz)
Remarks : IEEE802.11g
Date : 5/17/2007
Phase : Single Phase
Temperature : 22 °C
Humidity : 57 %
Regulation : FCC Part15C § 15.207. (CISPR Pub.22)

Engineer : Takahiro Suzuki

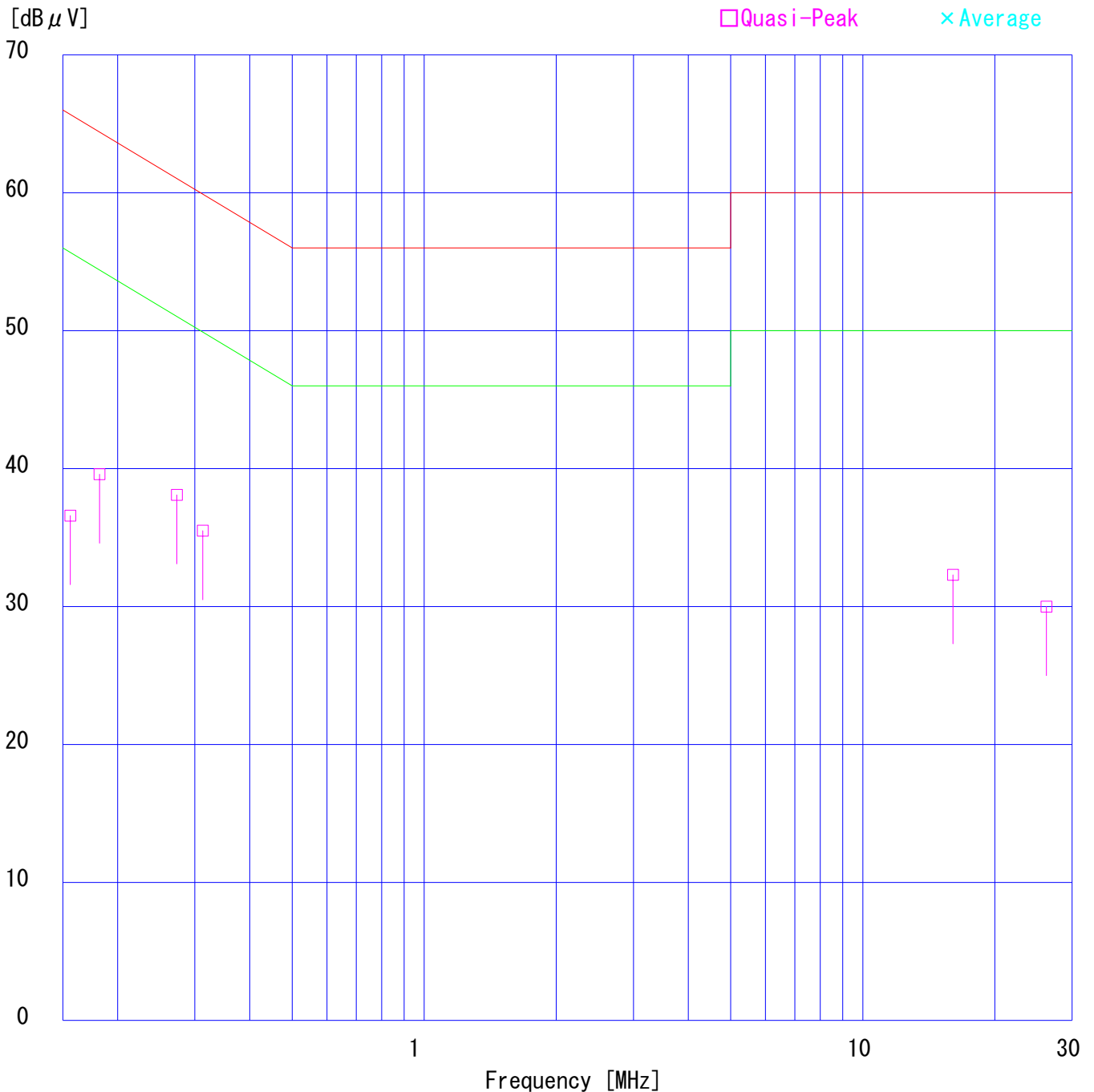

DATA OF CONDUCTION TEST CHART

UL Japan, Inc.
YAMAKITA No.2 SHIELD ROOM
Report No. : 271E0337-YK-A

Applicant : RICOH COMPANY, LTD.
Kind of Equipment : Option(s) for Radiocommunications
Model No. : R-WL54MN
Serial No. : 704S0191
Power : AC120V/60Hz
Mode : Transmitting (2412MHz)
Remarks : IEEE802.11g
Date : 5/17/2007
Phase : Single Phase
Temperature : 22 °C
Humidity : 57 %
Regulation 1 : FCC Part15C § 15.207. (CISPR Pub.22)
Regulation 2 : None

Engineer : Takahiro Suzuki

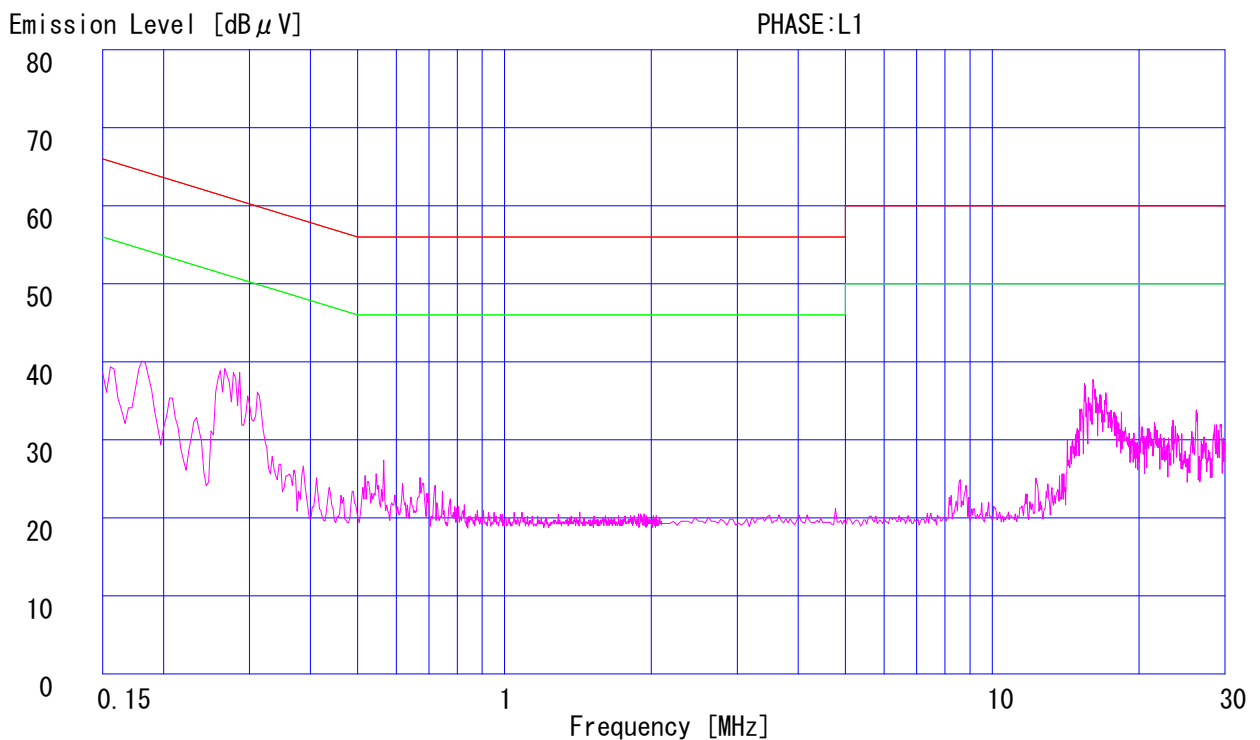
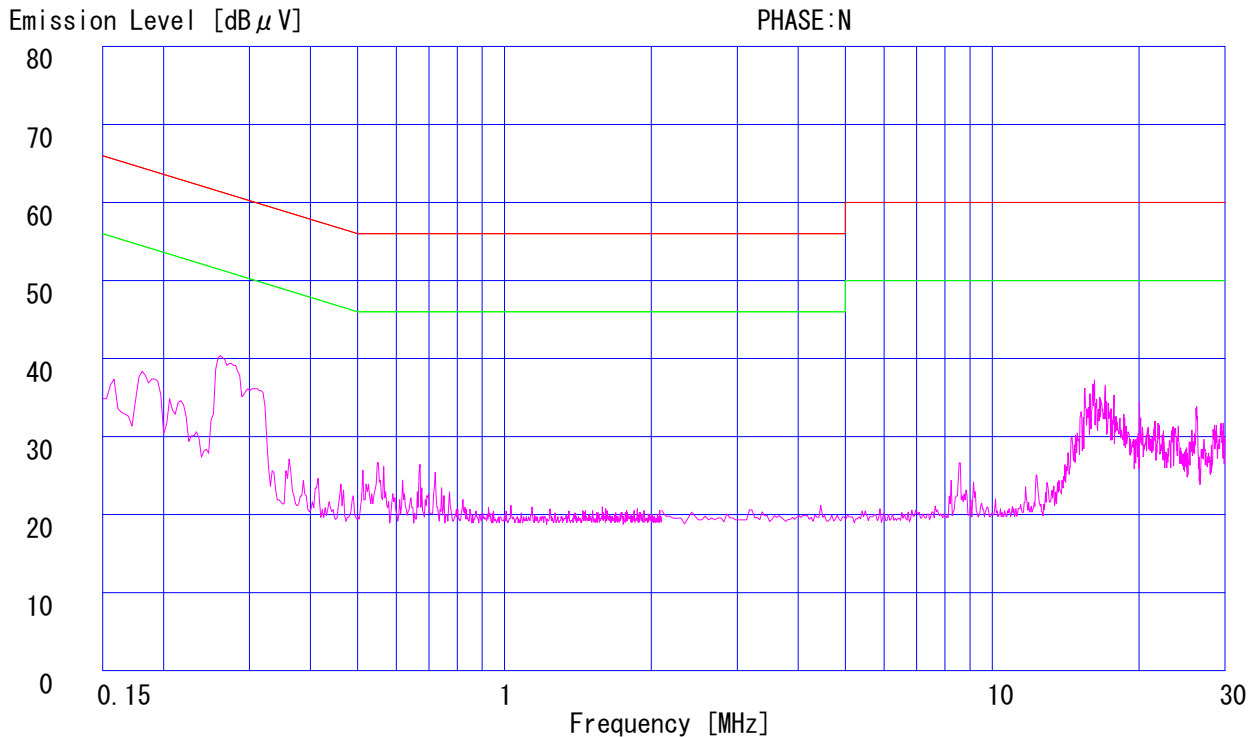

DATA OF CONDUCTION TEST CHART

UL Japan, Inc.
YAMAKITA No.2 SHIELD ROOM
Report No. : 271E0337-YK-A

Applicant : RICOH COMPANY, LTD.
Kind of Equipment : Option(s) for Radiocommunications
Model No. : R-WL54MN
Serial No. : 704S0191
Power : AC120V/60Hz
Mode : Transmitting (2437MHz)
Remarks : IEEE802.11g
Date : 5/17/2007
Phase : Single Phase
Temperature : 22 °C
Humidity : 57 %
Regulation 1 : FCC Part15C § 15.207. (CISPR Pub.22)
Regulation 2 : None

Engineer : Takahiro Suzuki

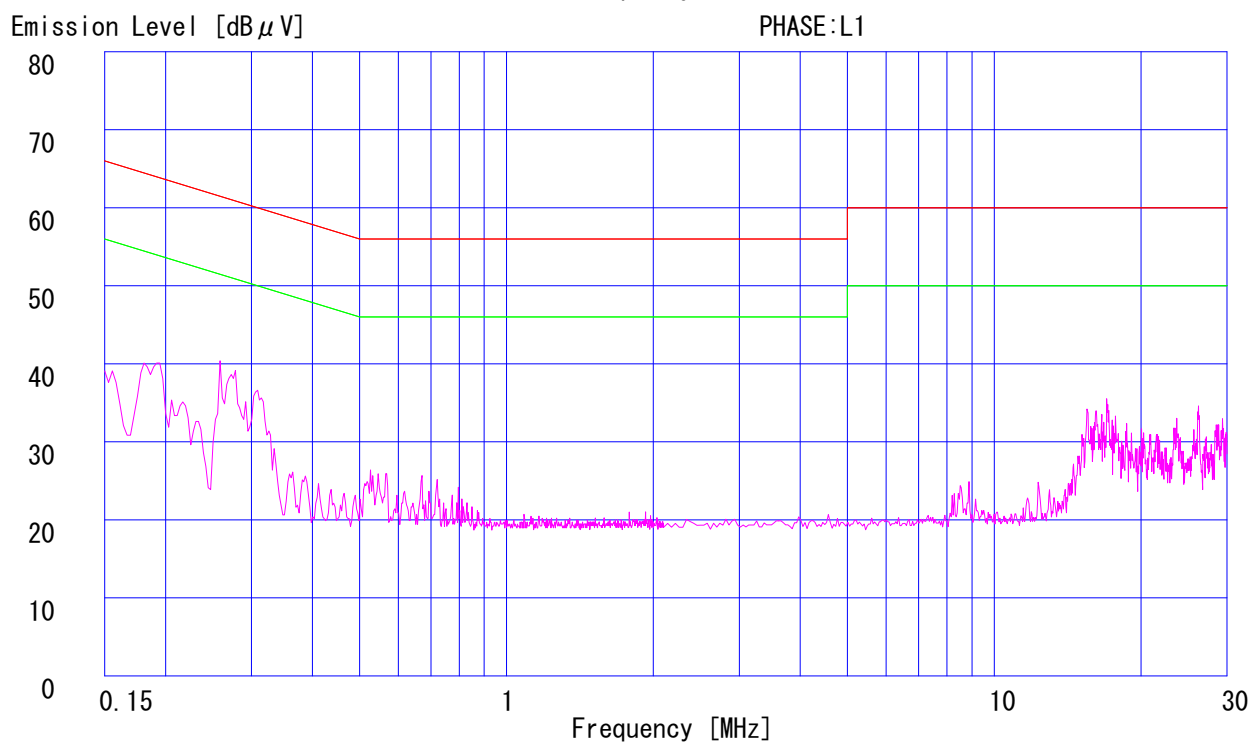
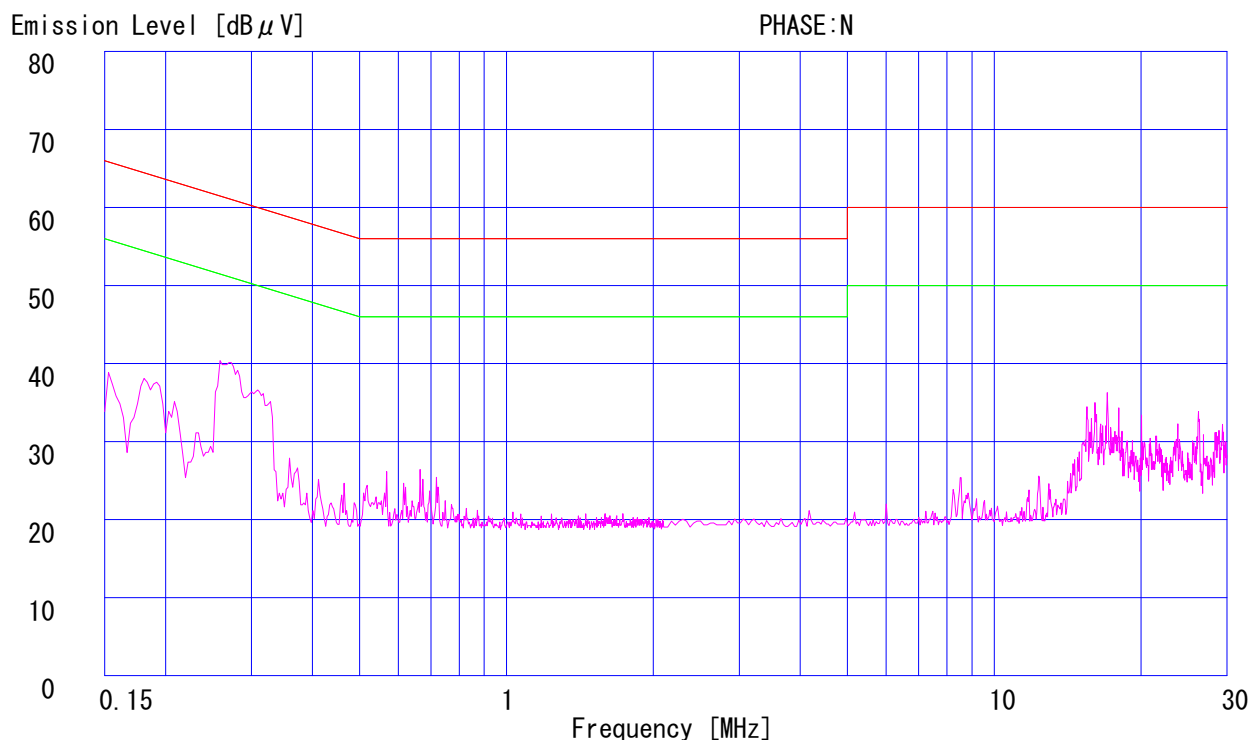

DATA OF CONDUCTION TEST CHART

UL Japan, Inc.
YAMAKITA No.2 SHIELD ROOM
Report No. : 271E0337-YK-A

Applicant : RICOH COMPANY, LTD.
Kind of Equipment : Option(s) for Radiocommunications
Model No. : R-WL54MN
Serial No. : 704S0191
Power : AC120V/60Hz
Mode : Transmitting (2462MHz)
Remarks : IEEE802.11g
Date : 5/17/2007
Phase : Single Phase
Temperature : 22 °C
Humidity : 57 %
Regulation 1 : FCC Part15C § 15.207. (CISPR Pub.22)
Regulation 2 : None

Engineer : Takahiro Suzuki

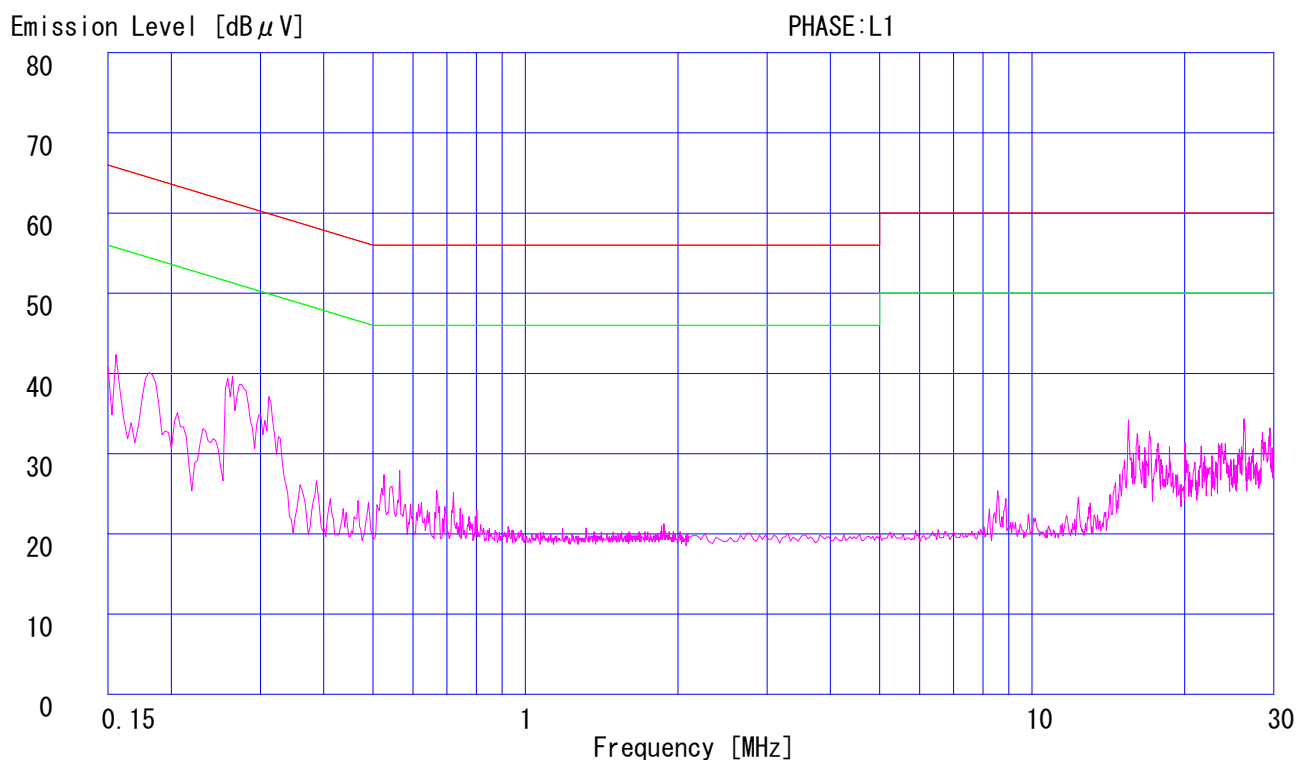
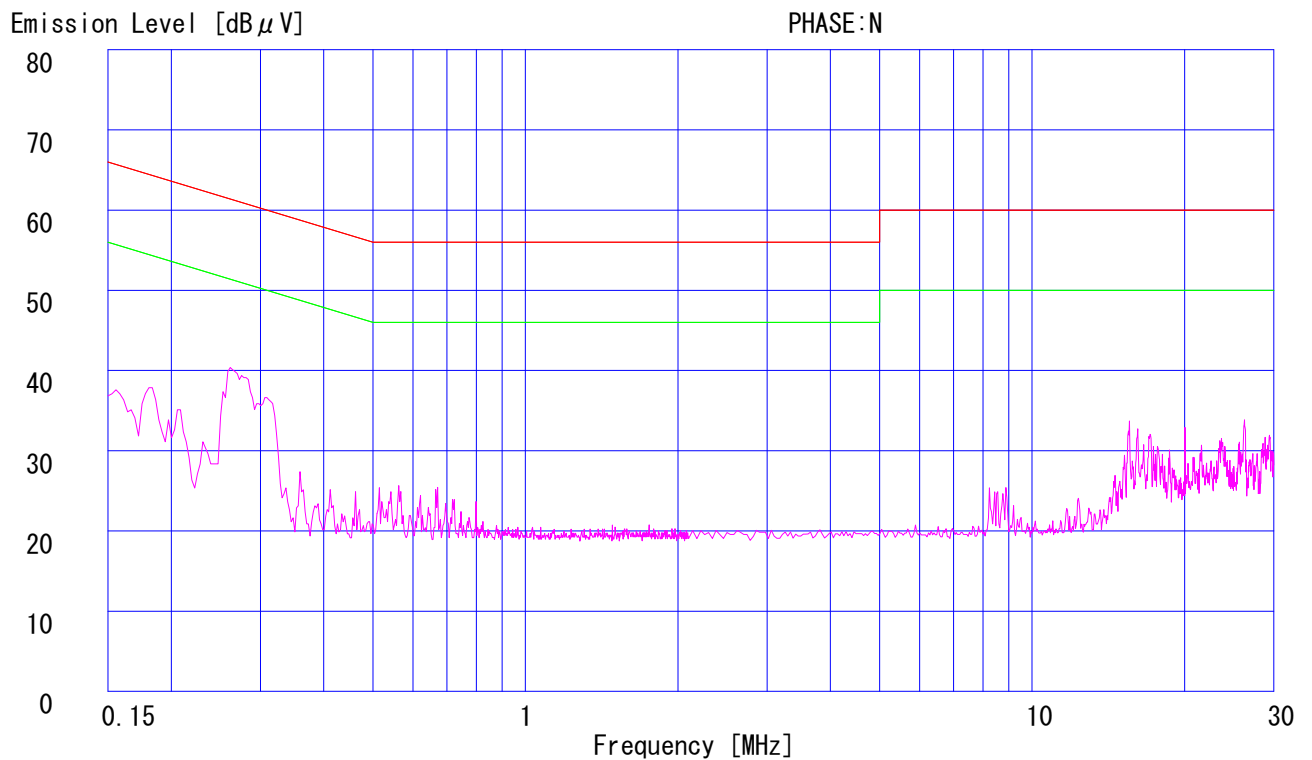

DATA OF CONDUCTION TEST CHART

UL Japan, Inc.
YAMAKITA No.2 SHIELD ROOM
Report No. : 271E0337-YK-A

Applicant : RICOH COMPANY, LTD.
Kind of Equipment : Option(s) for Radiocommunications
Model No. : R-WL54MN
Serial No. : 704S0191
Power : AC120V/60Hz
Mode : Receiving(2437MHz)
Remarks : IEEE802.11b/g
Date : 5/17/2007
Phase : Single Phase
Temperature : 22 °C
Humidity : 57 %
Regulation 1 : FCC Part15B CLASS B(CISPR Pub. 22)
Regulation 2 : None

Engineer : Takahiro Suzuki

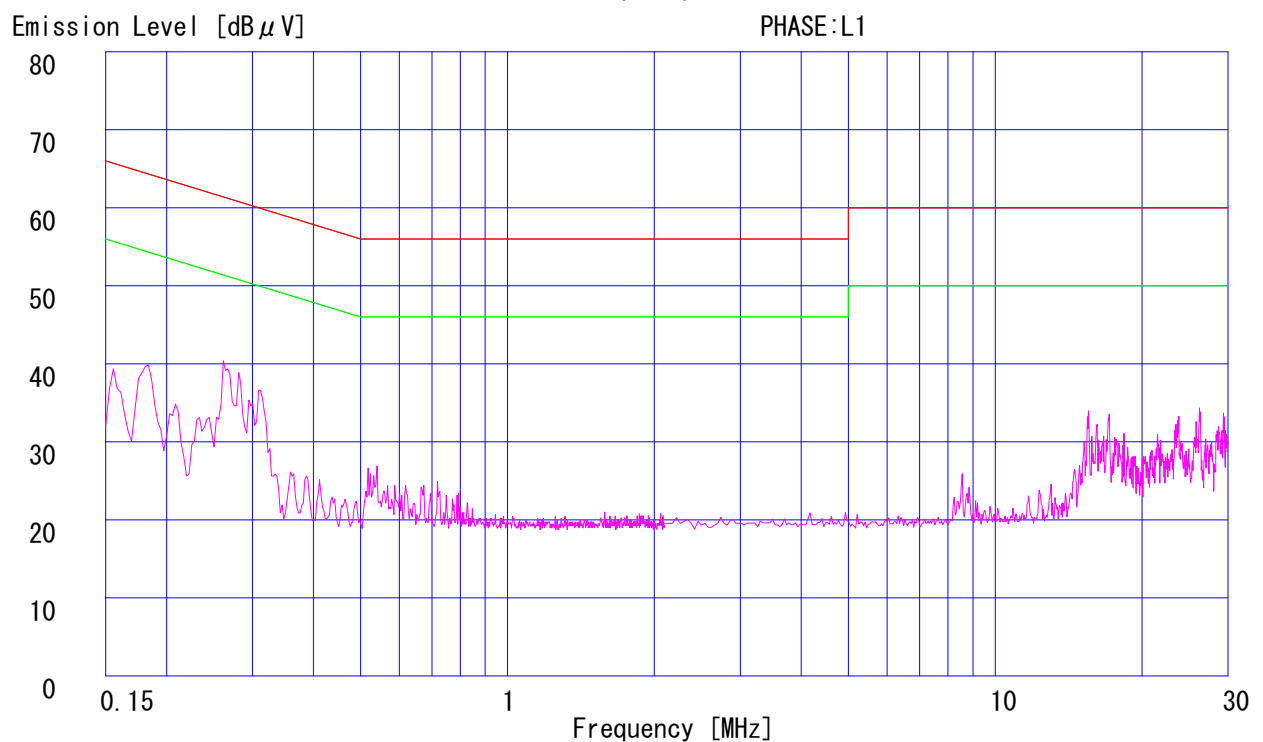
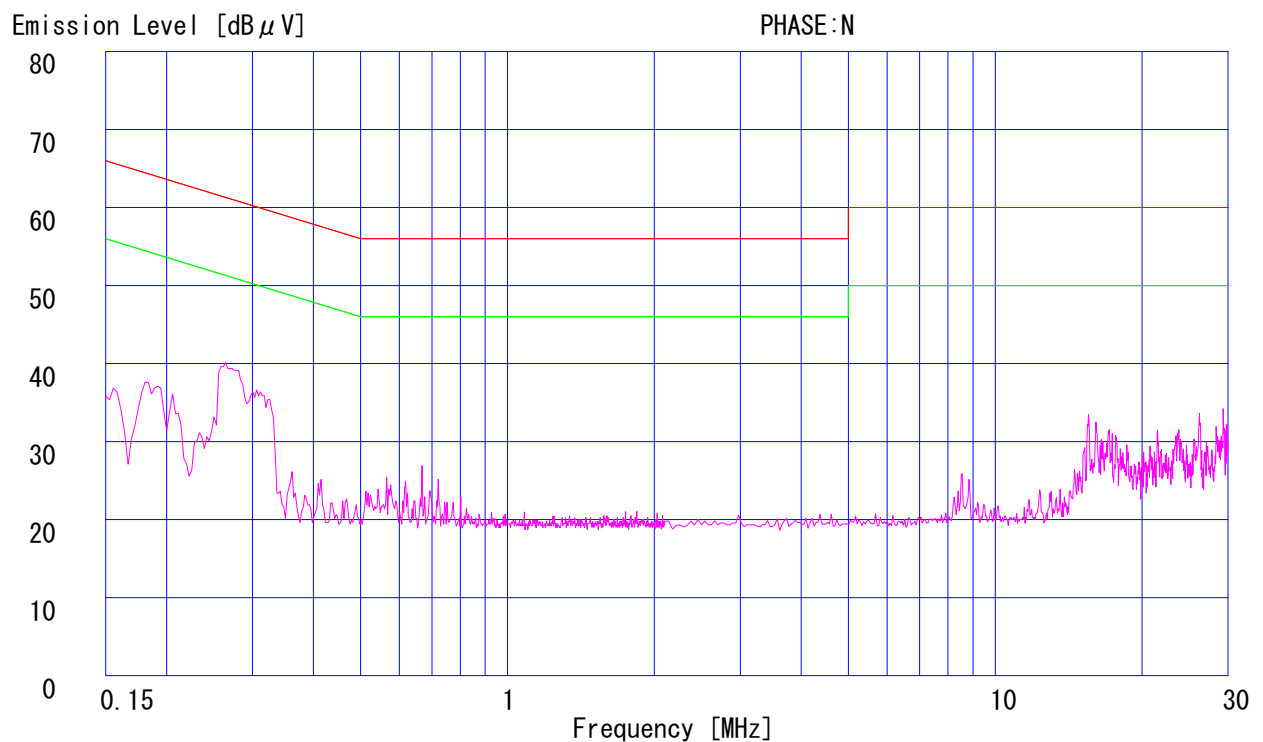

6dB Bandwidth: FCC 15.247(a)(2)

COMPANY : RICOH COMPANY, LTD
EQUIPMENT : Option(s) for Radiocommunications
MODEL NUMBER : R-WL54MN
SERIAL NUMBER : 704S0191
FCC ID : BBP-WLRWL541
POWER : AC120V/60Hz
 [IEEE802.11b(11Mbps)]

UL Japan, Inc. Yamakita No.2 Shielded Room
REPORT NO : 27IE0337-YK-A
REGULATION : Fcc Part15SubpartC 247(a)(2)
DATE : 2007/05/22
TEMP./HUMI : 24°C/53%
TEST MODE : Transmitting
ENGINEER : Tatsuya Arai

1. ch 1: 2412MHz/6dB Bandwidth:11.90MHz

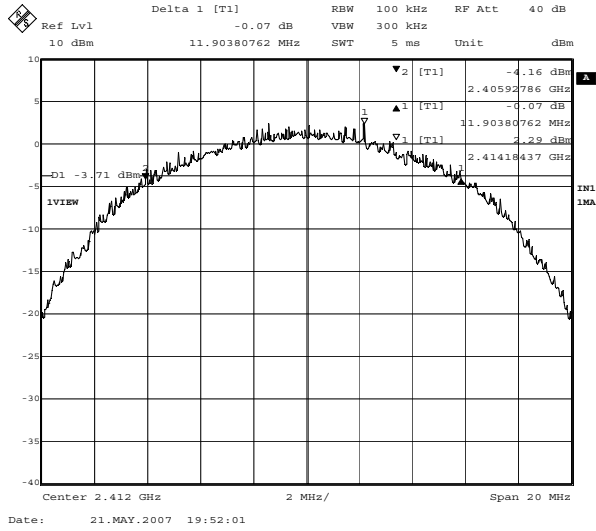

2. ch 6: 2437MHz/6dB Bandwidth:11.14MHz

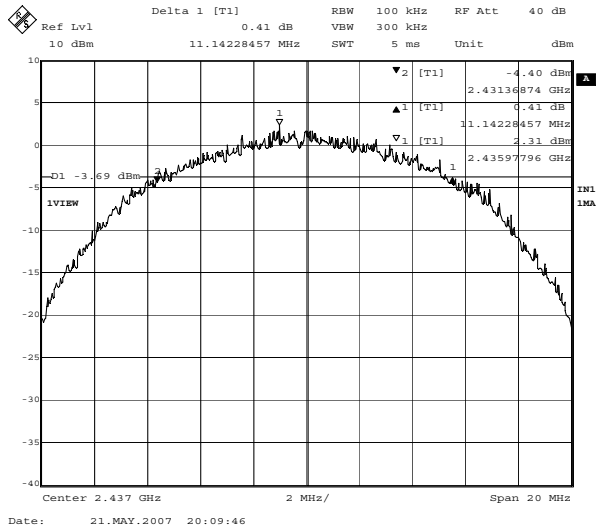

3. ch 11: 2462MHz/6dB Bandwidth:11.58MHz

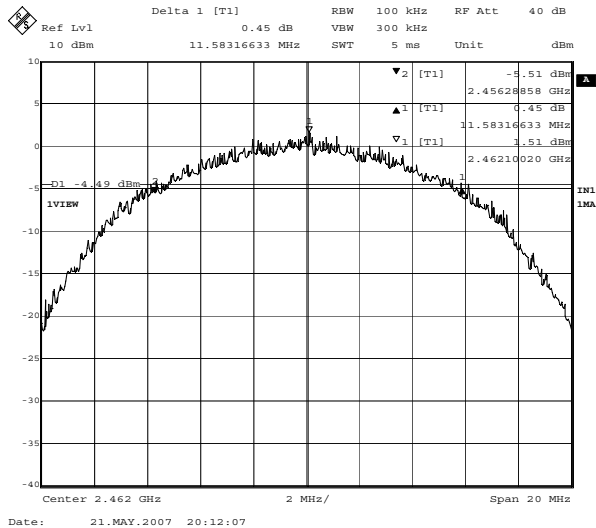

6dB Bandwidth: FCC 15.247(a)(2)

COMPANY : RICOH COMPANY, LTD
EQUIPMENT : Option(s) for Radiocommunications
MODEL NUMBER : R-WL54MN
SERIAL NUMBER : 704S0191
FCC ID : BBP-WLRWL541
POWER : AC120V/60Hz
[IEEE802.11g(54Mbps)]

UL Japan, Inc. Yamakita No.2 Shielded Room
REPORT NO : 27IE0337-YK-A
REGULATION : Fcc Part15SubpartC 247(a)(2)
DATE : 2007/05/22
TEMP./HUMI : 24°C/53%
TEST MODE : Transmitting
ENGINEER : Tatsuya Arai

1. ch 1: 2412MHz/6dB Bandwidth:16.55MHz

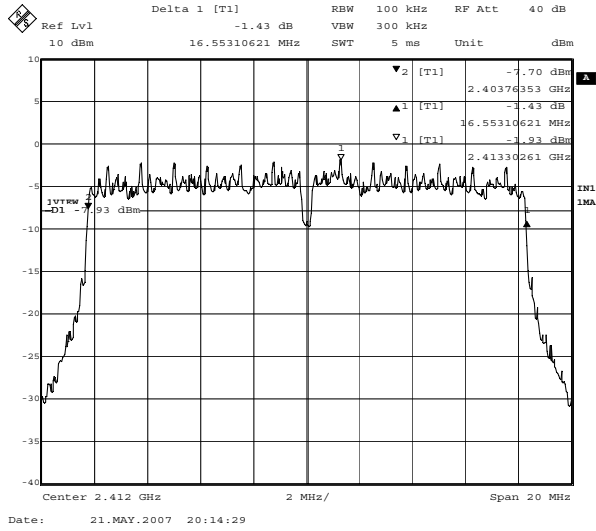

2. ch 6: 2437MHz/6dB Bandwidth:16.51MHz

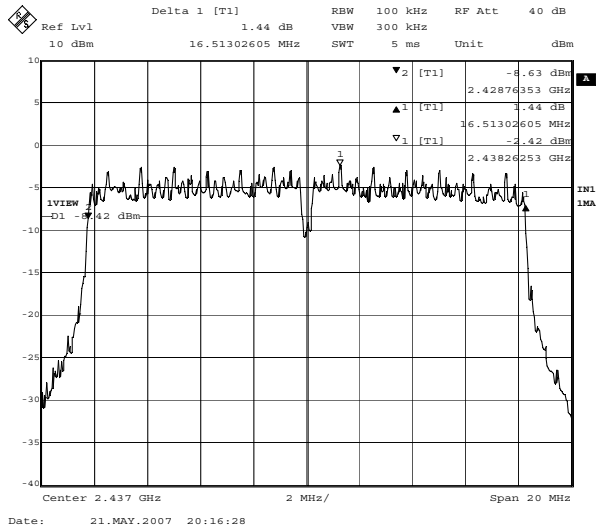

3. ch 11: 2462MHz/6dB Bandwidth:16.55MHz

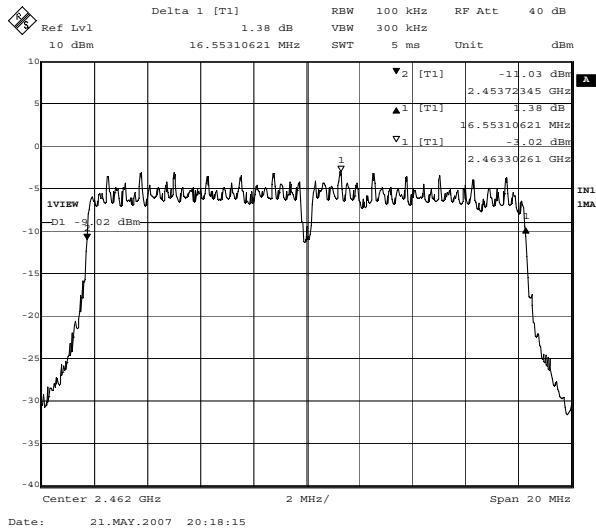

Maximum Peak Conducted Output Power

UL Japan, Inc.

YAMAKITA NO.2 Shielded Room

COMPANY : RICOH COMPANY, LTD REPORT NO : 27IE0337-YK-A
EQUIPMENT : Option(s) for Radiocommunications REGULATION : Fcc Part15SubpartC 247(b)(3)
MODEL NUMBER: R-WL54MN DATE : 2007/05/22
SERIAL NUMBER: 704S0191 TEMP./HUMI : 24°C/53%
FCC ID : BBP-WLRWL541
POWER : AC120V/60Hz
TEST MODE : Transmitting

ENGINEER : Tatsuya Arai

IEEE802.11b(11Mbps)

CH	FREQ [GHz]	PM Reading [dBm]	Cable Loss [dB]	Results [dBm]	Limit (1W) [dBm]	MARGIN [dB]
Low	2412.00	14.60	1.3	15.90	30.0	14.10
Mid	2437.00	14.49	1.3	15.79	30.0	14.21
High	2462.00	13.61	1.3	14.91	30.0	15.09

IEEE802.11g(54Mbps)

CH	FREQ [GHz]	PM Reading [dBm]	Cable Loss [dB]	Results [dBm]	Limit (1W) [dBm]	MARGIN [dB]
Low	2412.00	19.32	1.3	20.62	30.0	9.38
Mid	2437.00	18.96	1.3	20.26	30.0	9.74
High	2462.00	18.13	1.3	19.43	30.0	10.57

Sample Calculation:

Result = Reading + Cable Loss

Out of Band Emission(Antenna Terminal Conducted): FCC 15.247(d)

COMPANY : RICOH COMPANY, LTD
EQUIPMENT : Option(s) for Radiocommunications
MODEL NUMBER : R-WL54MN
SERIAL NUMBER : 704S0191
FCC ID : BBP-WLRWL541
POWER : AC120V/60Hz

UL Japan, Inc. Yamakita No.2 Shielded Room
REPORT NO : 27IE0337-YK-A
REGULATION : Fcc Part15SubpartC 247(d)
DATE : 2007/05/22
TEMP./HUMI : 24deg.C./53%
Test Mode : Transmitting/Receiving
ENGINEER : Tatsuya Arai

[IEEE802.11b (11Mbps)]
Transmitting Ch:2412MHz

1.

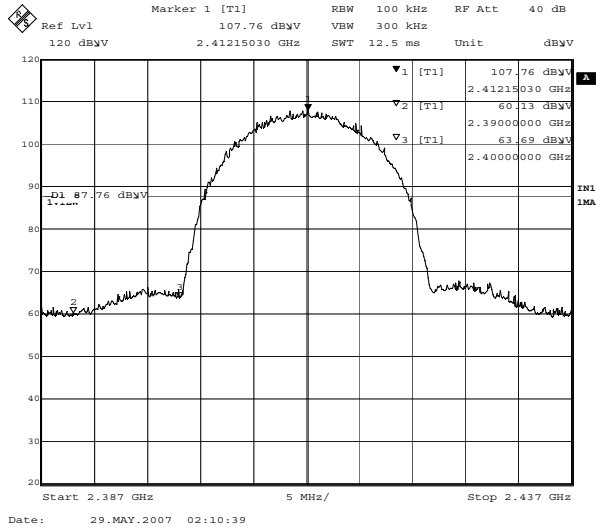

2.

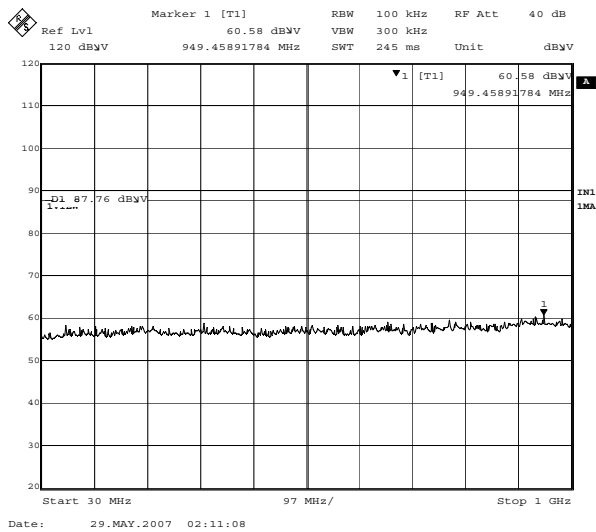

3.

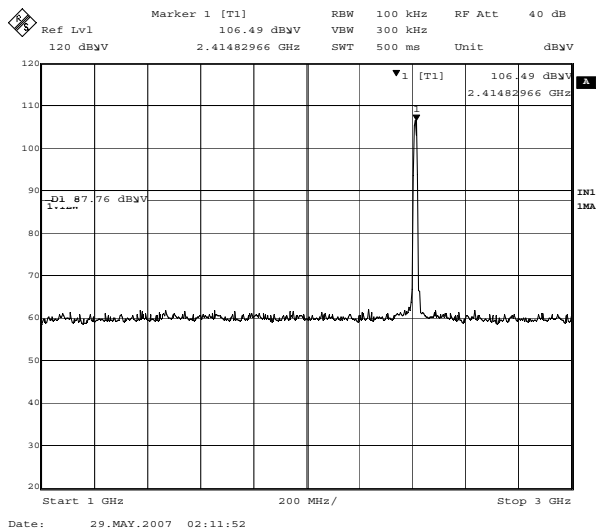

Out of Band Emission(Antenna Terminal Conducted): FCC 15.247(d)

COMPANY : RICOH COMPANY, LTD
EQUIPMENT : Option(s) for Radiocommunications
MODEL NUMBER: R-WL54MN
SERIAL NUMBER: 704S0191
FCC ID : BBP-WLRWL541
POWER : AC120V/60Hz

UL Japan, Inc. Yamakita No.2 Shielded Room
REPORT NO : 27IE0337-YK-A
REGULATION : Fcc Part15SubpartC 247(d)
DATE : 2007/05/22
TEMP./HUMI : 24deg.C./53%
Test Mode : Transmitting/Receiving
ENGINEER : Tatsuya Arai

[IEEE802.11b (11Mbps)]
Transmitting Ch:2412MHz

4.

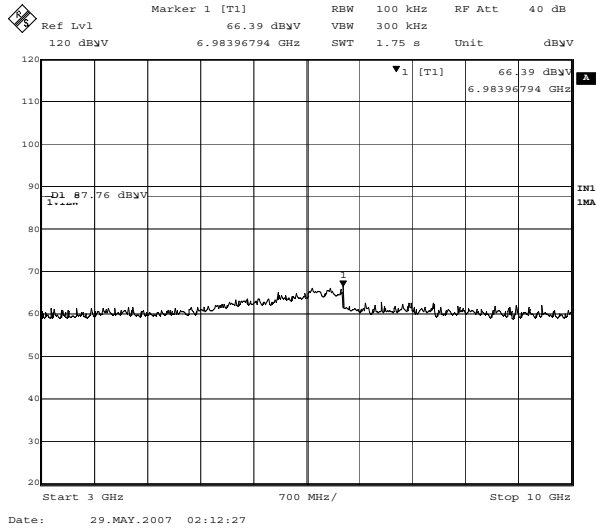

5.

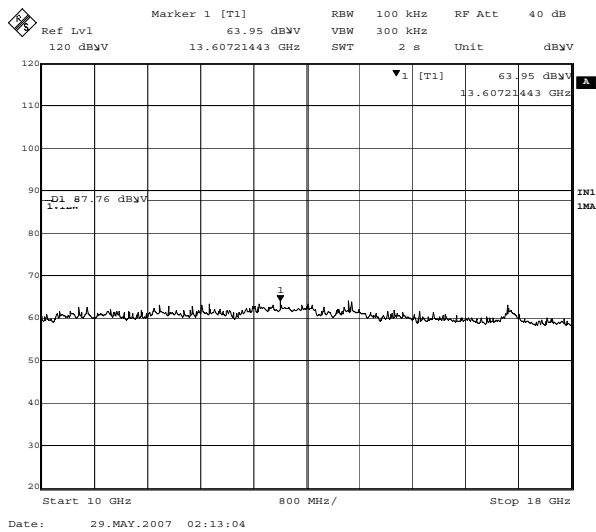

6.

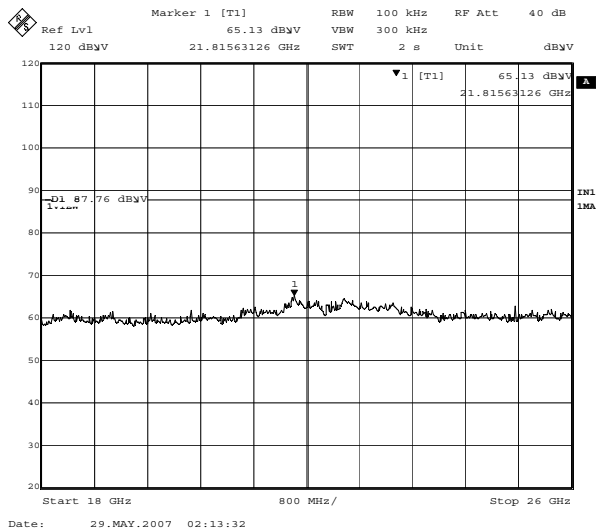

Out of Band Emission(Antenna Terminal Conducted): FCC 15.247(d)

COMPANY : RICOH COMPANY, LTD
EQUIPMENT : Option(s) for Radiocommunications
MODEL NUMBER: R-WL54MN
SERIAL NUMBER: 704S0191
FCC ID : BBP-WLRWL541
POWER : AC120V/60Hz

UL Japan, Inc. Yamakita No.2 Shielded Room
REPORT NO : 27IE0337-YK-A
REGULATION : Fcc Part15SubpartC 247(d)
DATE : 2007/05/22
TEMP./HUMI : 24deg.C./53%
Test Mode : Transmitting/Receiving
ENGINEER : Tatsuya Arai

[IEEE802.11b (11Mbps)]
Transmitting Ch:2437MHz

1.

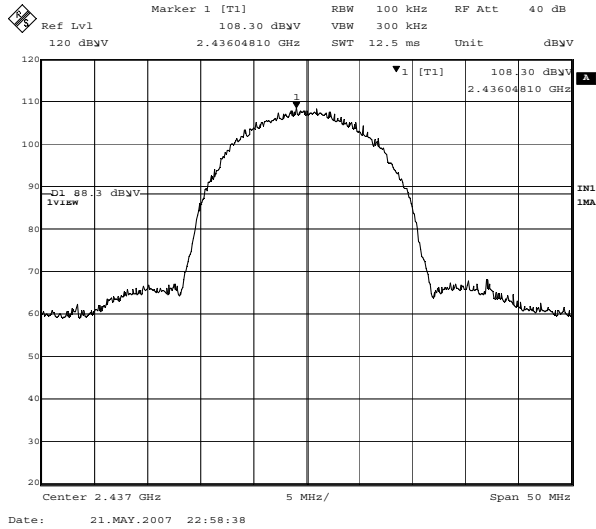

2.

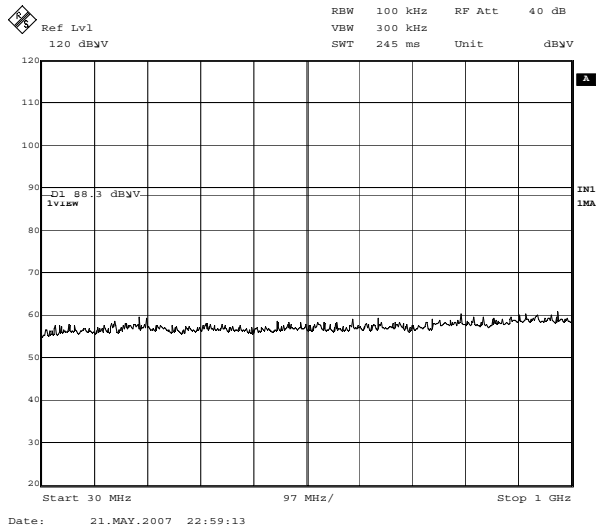

3.

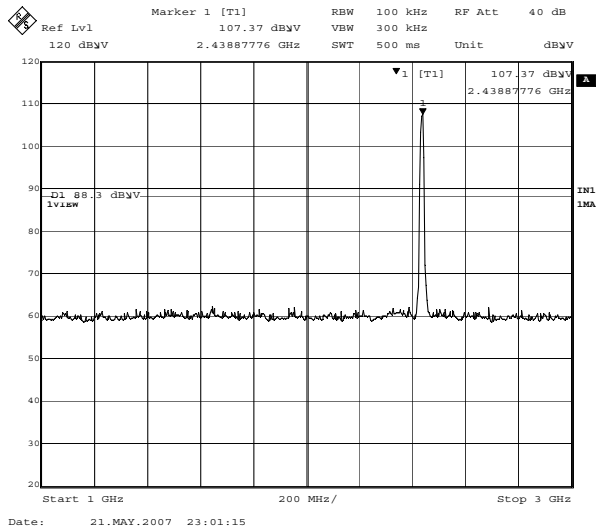

Out of Band Emission(Antenna Terminal Conducted): FCC 15.247(d)

COMPANY : RICOH COMPANY, LTD
EQUIPMENT : Option(s) for Radiocommunications
MODEL NUMBER: R-WL54MN
SERIAL NUMBER: 704S0191
FCC ID : BBP-WLRWL541
POWER : AC120V/60Hz

UL Japan, Inc. Yamakita No.2 Shielded Room
REPORT NO : 27IE0337-YK-A
REGULATION : Fcc Part15SubpartC 247(d)
DATE : 2007/05/22
TEMP./HUMI : 24deg.C./53%
Test Mode : Transmitting/Receiving
ENGINEER : Tatsuya Arai

[IEEE802.11b (11Mbps)]
Transmitting Ch:2437MHz

4.

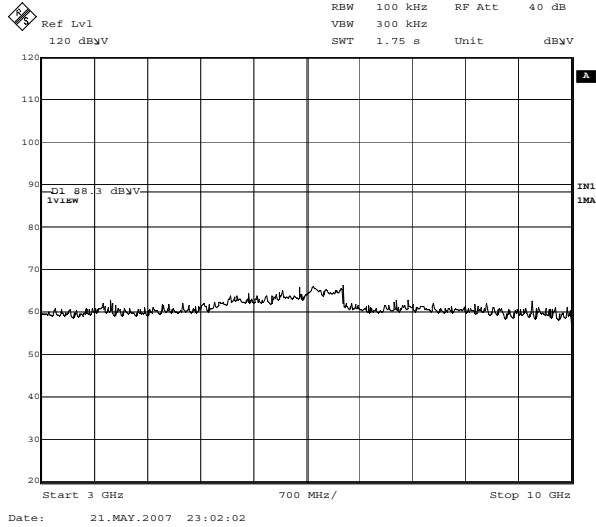

5.

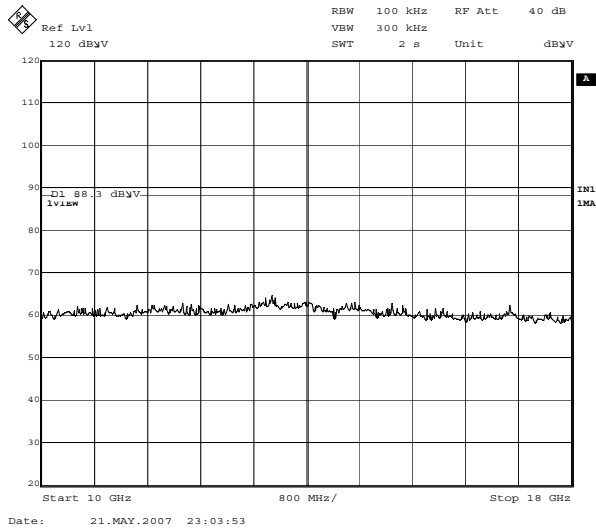

6.

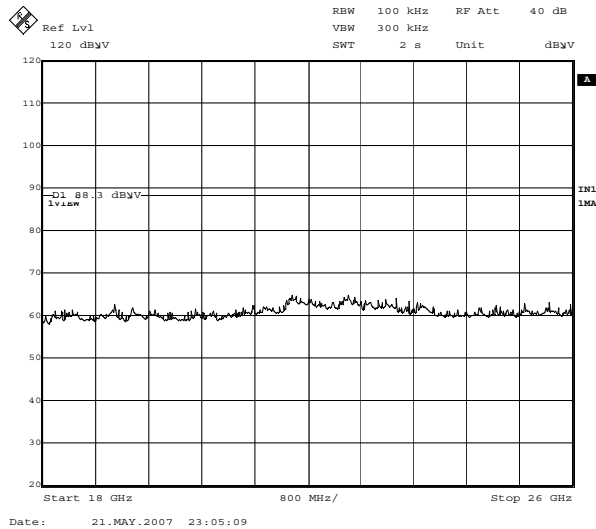

Out of Band Emission(Antenna Terminal Conducted): FCC 15.247(d)

COMPANY : RICOH COMPANY, LTD
EQUIPMENT : Option(s) for Radiocommunications
MODEL NUMBER: R-WL54MN
SERIAL NUMBER: 704S0191
FCC ID : BBP-WLRWL541
POWER : AC120V/60Hz

UL Japan, Inc. Yamakita No.2 Shielded Room
REPORT NO : 27IE0337-YK-A
REGULATION : Fcc Part15SubpartC 247(d)
DATE : 2007/05/22
TEMP./HUMI : 24deg.C./53%
Test Mode : Transmitting/Receiving
ENGINEER : Tatsuya Arai

[IEEE802.11b (11Mbps)]
Transmitting Ch:2462MHz

1.

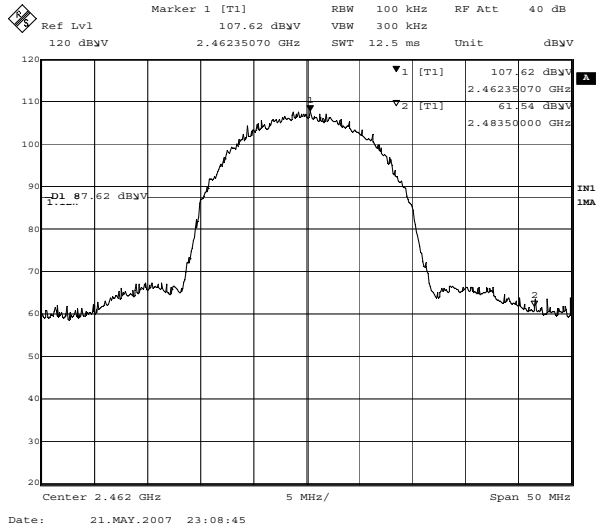

2.

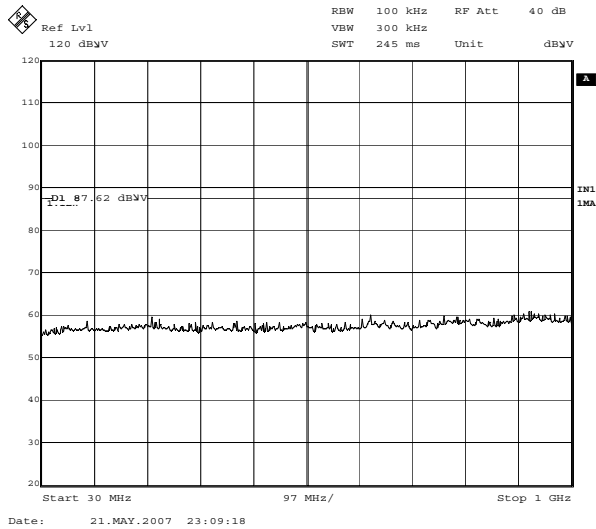

3.

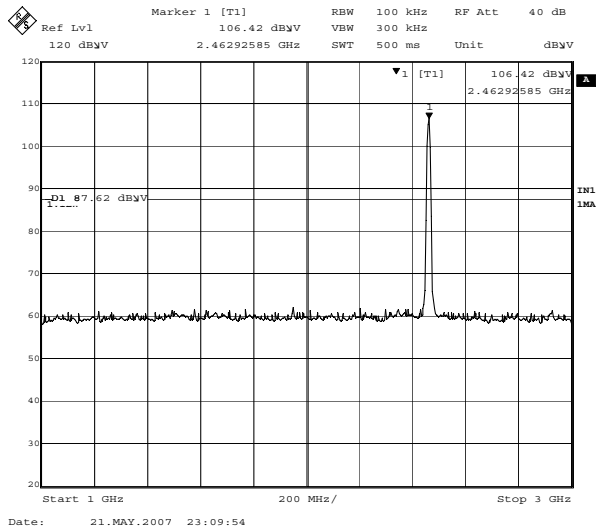

Out of Band Emission(Antenna Terminal Conducted): FCC 15.247(d)

COMPANY : RICOH COMPANY, LTD
EQUIPMENT : Option(s) for Radiocommunications
MODEL NUMBER: R-WL54MN
SERIAL NUMBER: 704S0191
FCC ID : BBP-WLRWL541
POWER : AC120V/60Hz

UL Japan, Inc. Yamakita No.2 Shielded Room
REPORT NO : 27IE0337-YK-A
REGULATION : Fcc Part15SubpartC 247(d)
DATE : 2007/05/22
TEMP./HUMI : 24deg.C./53%
Test Mode : Transmitting/Receiving
ENGINEER : Tatsuya Arai

[IEEE802.11b (11Mbps)]
Transmitting Ch:2462MHz

4.

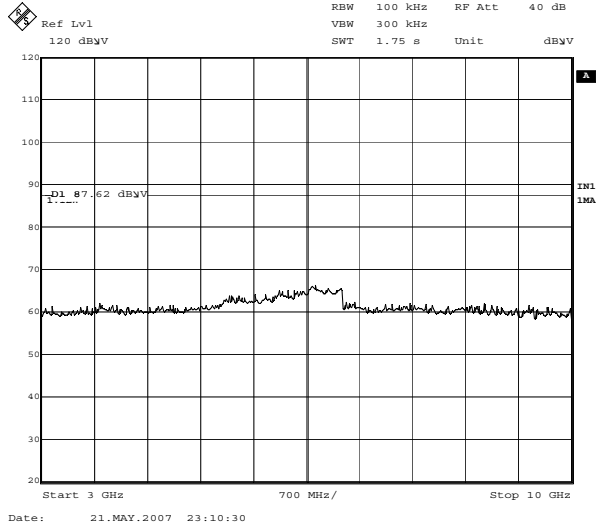

5.

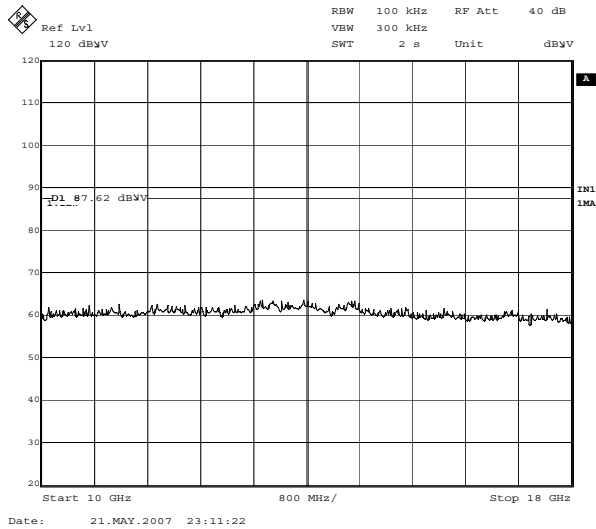

6.

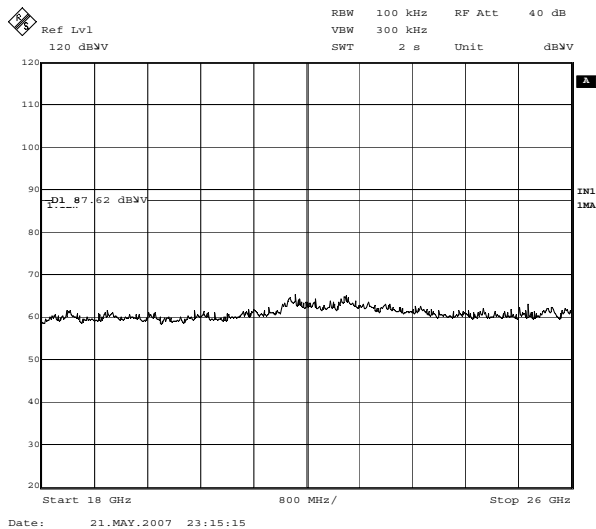

Out of Band Emission(Antenna Terminal Conducted): FCC 15.247(d)

COMPANY : RICOH COMPANY, LTD
EQUIPMENT : Option(s) for Radiocommunications
MODEL NUMBER : R-WL54MN
SERIAL NUMBER : 704S0191
FCC ID : BBP-WLRWL541
POWER : AC120V/60Hz

UL Japan, Inc. Yamakita No.2 Shielded Room
REPORT NO : 27IE0337-YK-A
REGULATION : Fcc Part15SubpartC 247(d)
DATE : 2007/05/22
TEMP./HUMI : 24deg.C./53%
Test Mode : Transmitting/Receiving
ENGINEER : Tatsuya Arai

[IEEE802.11g (54Mbps)]
Transmitting Ch:2412MHz

1.

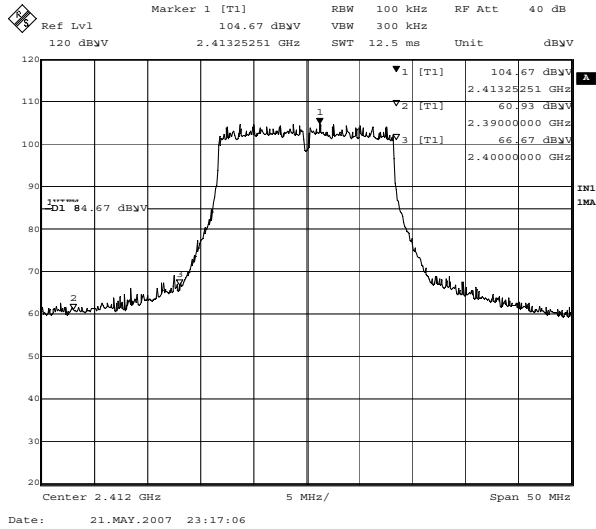

2.

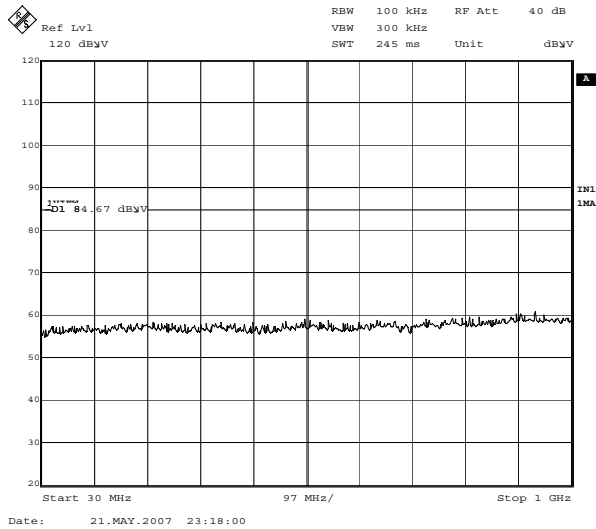

3.

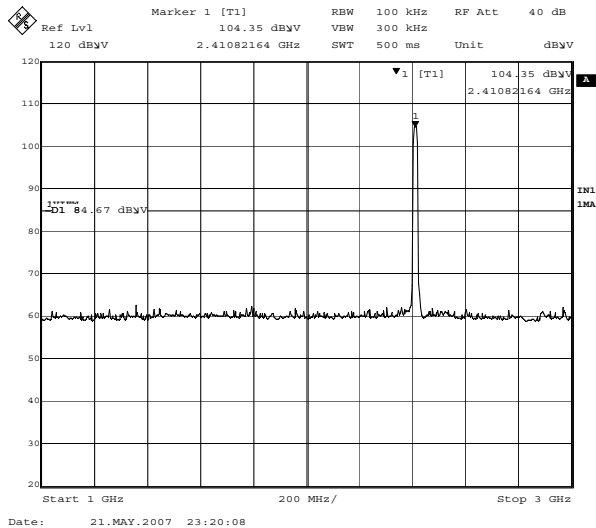

Out of Band Emission(Antenna Terminal Conducted): FCC 15.247(d)

COMPANY : RICOH COMPANY, LTD
EQUIPMENT : Option(s) for Radiocommunications
MODEL NUMBER: R-WL54MN
SERIAL NUMBER: 704S0191
FCC ID : BBP-WLRWL541
POWER : AC120V/60Hz

UL Japan, Inc. Yamakita No.2 Shielded Room
REPORT NO : 27IE0337-YK-A
REGULATION : Fcc Part15SubpartC 247(d)
DATE : 2007/05/22
TEMP./HUMI : 24deg.C./53%
Test Mode : Transmitting/Receiving
ENGINEER : Tatsuya Arai

[IEEE802.11g (54Mbps)]
Transmitting Ch:2412MHz

4.

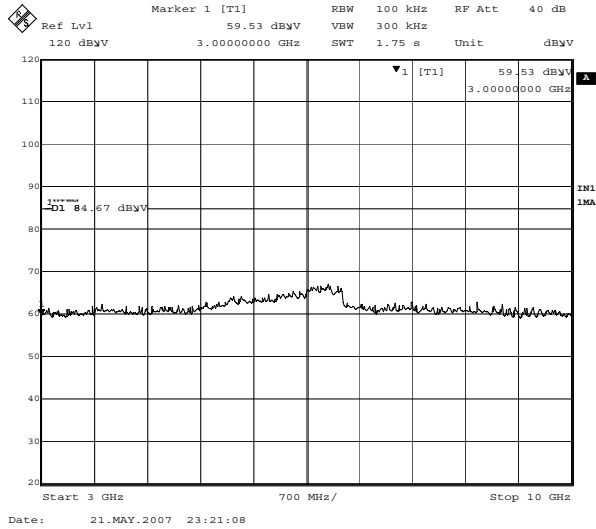

5.

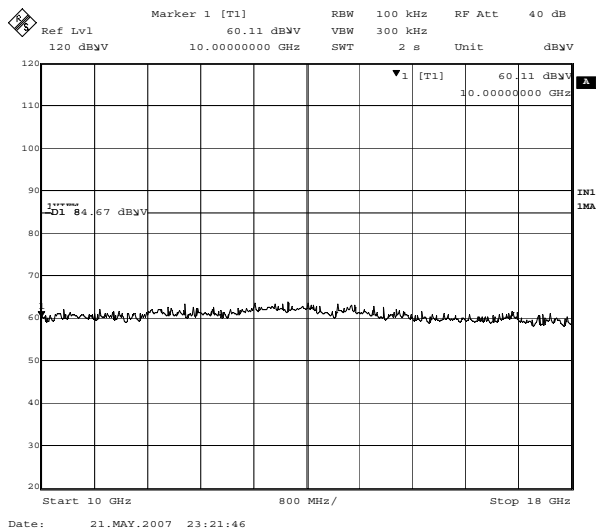

6.

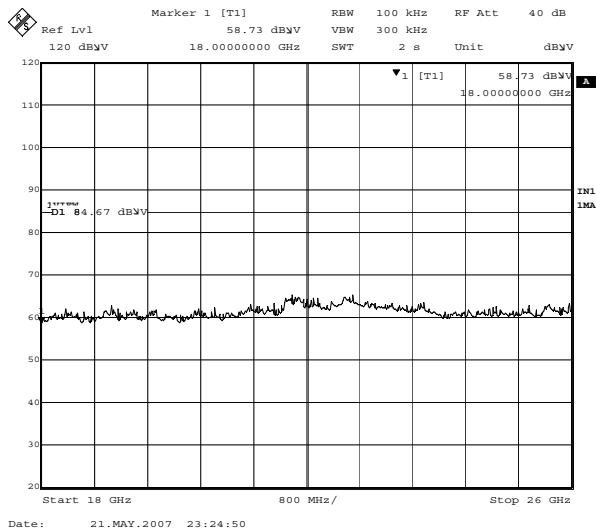

Out of Band Emission(Antenna Terminal Conducted): FCC 15.247(d)

COMPANY : RICOH COMPANY, LTD
EQUIPMENT : Option(s) for Radiocommunications
MODEL NUMBER: R-WL54MN
SERIAL NUMBER: 704S0191
FCC ID : BBP-WLRWL541
POWER : AC120V/60Hz

UL Japan, Inc. Yamakita No.2 Shielded Room
REPORT NO : 27IE0337-YK-A
REGULATION : Fcc Part15SubpartC 247(d)
DATE : 2007/05/22
TEMP./HUMI : 24deg.C./53%
Test Mode : Transmitting/Receiving
ENGINEER : Tatsuya Arai

[IEEE802.11g (54Mbps)]
Transmitting Ch:2437MHz

1.

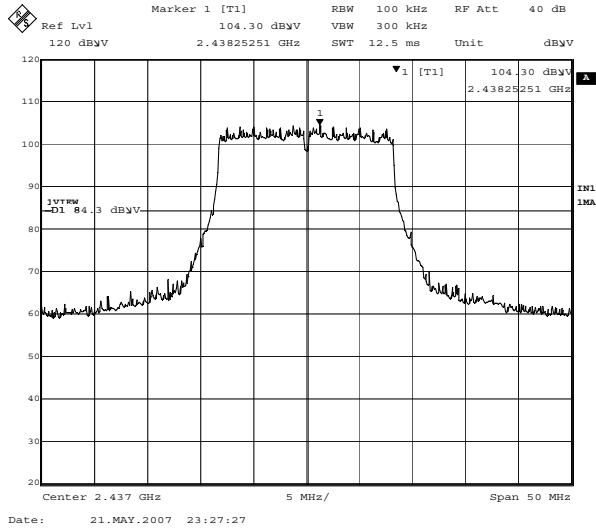

2.

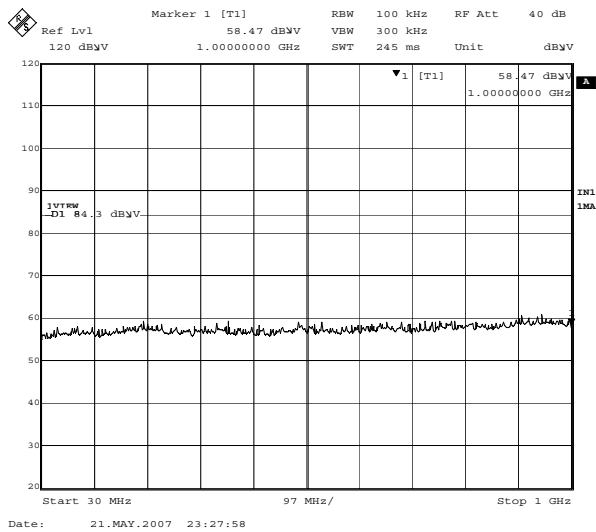

3.

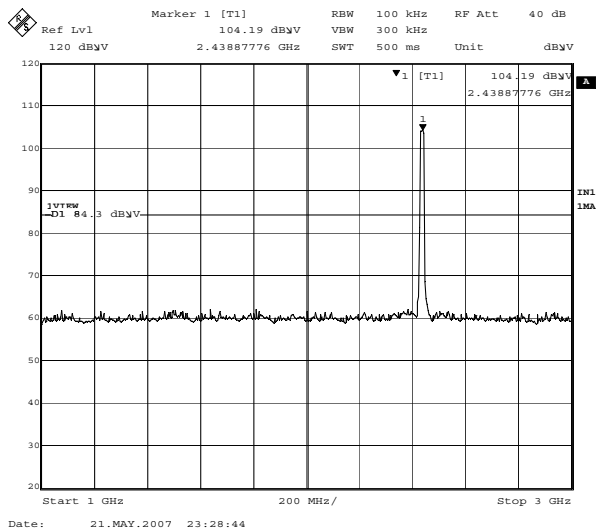

Out of Band Emission(Antenna Terminal Conducted): FCC 15.247(d)

COMPANY : RICOH COMPANY, LTD
EQUIPMENT : Option(s) for Radiocommunications
MODEL NUMBER: R-WL54MN
SERIAL NUMBER: 704S0191
FCC ID : BBP-WLRWL541
POWER : AC120V/60Hz

UL Japan, Inc. Yamakita No.2 Shielded Room
REPORT NO : 27IE0337-YK-A
REGULATION : Fcc Part15SubpartC 247(d)
DATE : 2007/05/22
TEMP./HUMI : 24deg.C./53%
Test Mode : Transmitting/Receiving
ENGINEER : Tatsuya Arai

[IEEE802.11g (54Mbps)]
Transmitting Ch:2437MHz

4.

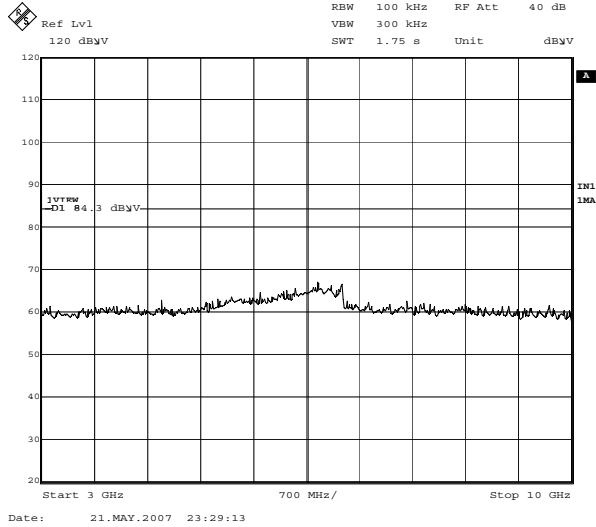

5.

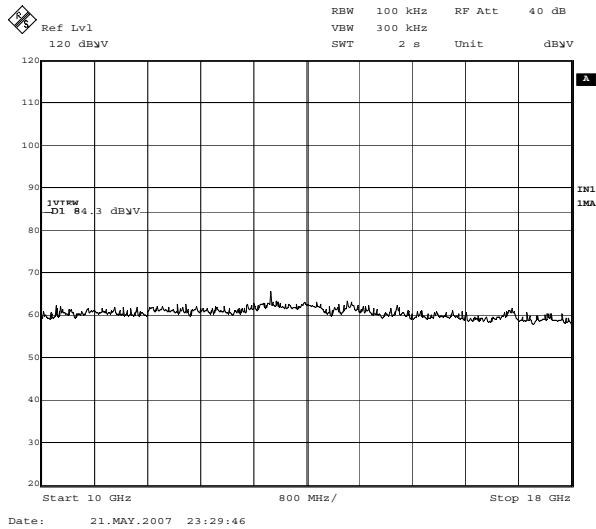

6.

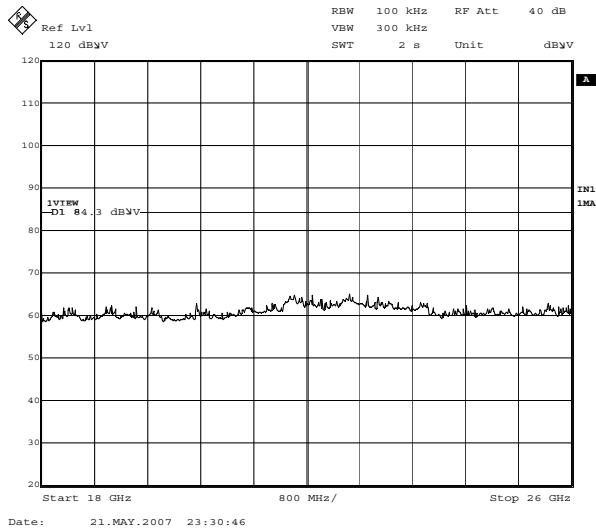

Out of Band Emission(Antenna Terminal Conducted): FCC 15.247(d)

COMPANY : RICOH COMPANY, LTD
EQUIPMENT : Option(s) for Radiocommunications
MODEL NUMBER: R-WL54MN
SERIAL NUMBER: 704S0191
FCC ID : BBP-WLRWL541
POWER : AC120V/60Hz

UL Japan, Inc. Yamakita No.2 Shielded Room
REPORT NO : 27IE0337-YK-A
REGULATION : Fcc Part15SubpartC 247(d)
DATE : 2007/05/22
TEMP./HUMI : 24deg.C./53%
Test Mode : Transmitting/Receiving
ENGINEER : Tatsuya Arai

[IEEE802.11g (54Mbps)]
Transmitting Ch:2462MHz

1.

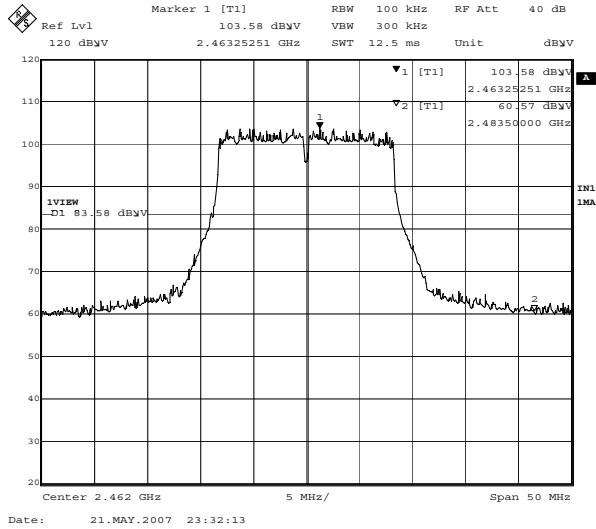

2.

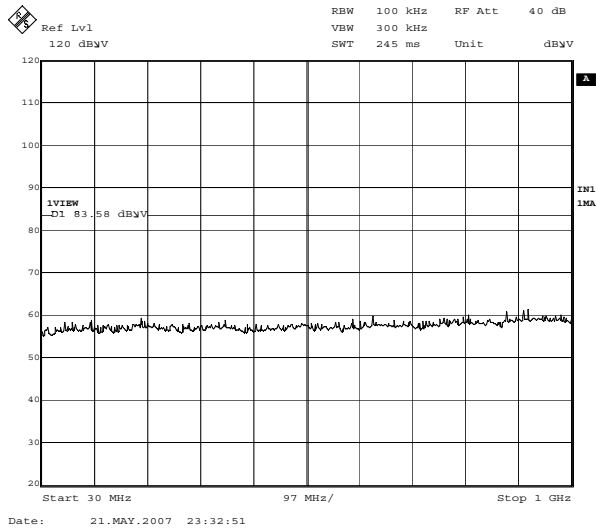

3.

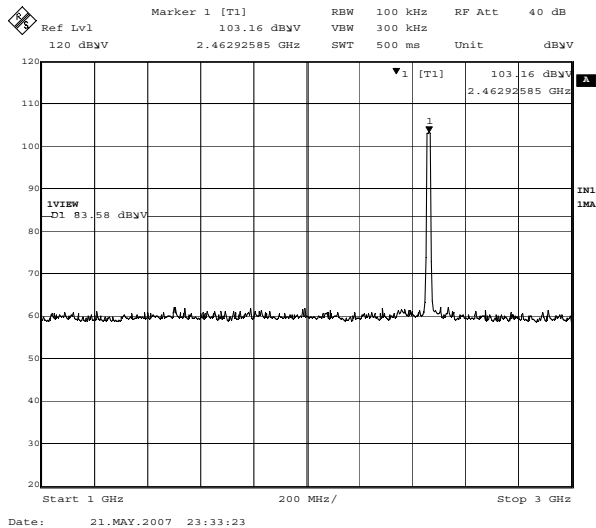

Out of Band Emission(Antenna Terminal Conducted): FCC 15.247(d)

COMPANY : RICOH COMPANY, LTD
EQUIPMENT : Option(s) for Radiocommunications
MODEL NUMBER: R-WL54MN
SERIAL NUMBER: 704S0191
FCC ID : BBP-WLRWL541
POWER : AC120V/60Hz

UL Japan, Inc. Yamakita No.2 Shielded Room
REPORT NO : 27IE0337-YK-A
REGULATION : Fcc Part15SubpartC 247(d)
DATE : 2007/05/22
TEMP./HUMI : 24deg.C./53%
Test Mode : Transmitting/Receiving
ENGINEER : Tatsuya Arai

[IEEE802.11g (54Mbps)]
Transmitting Ch:2462MHz

4.

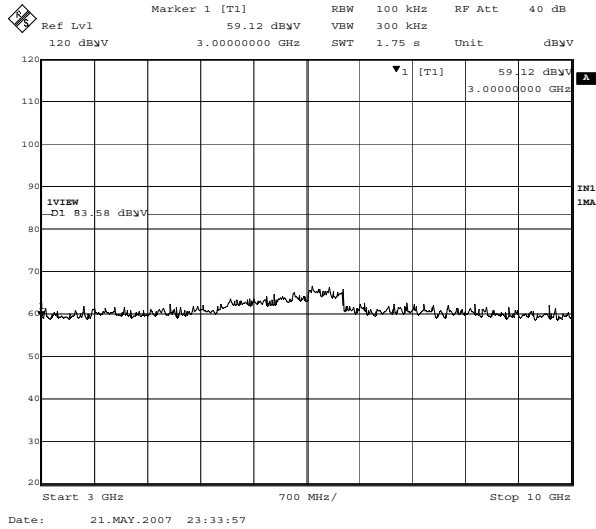

5.

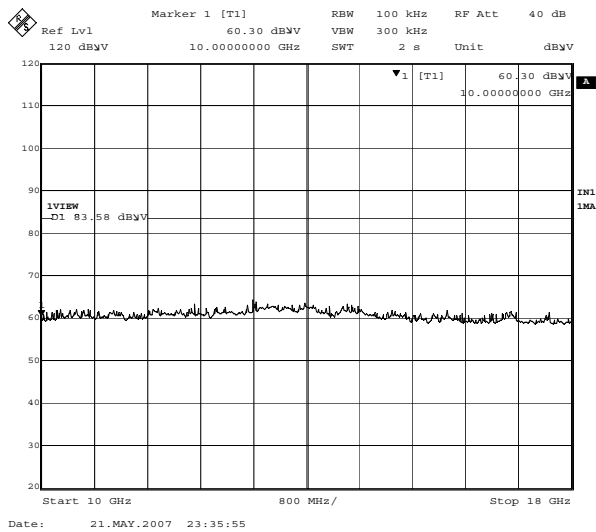

6.

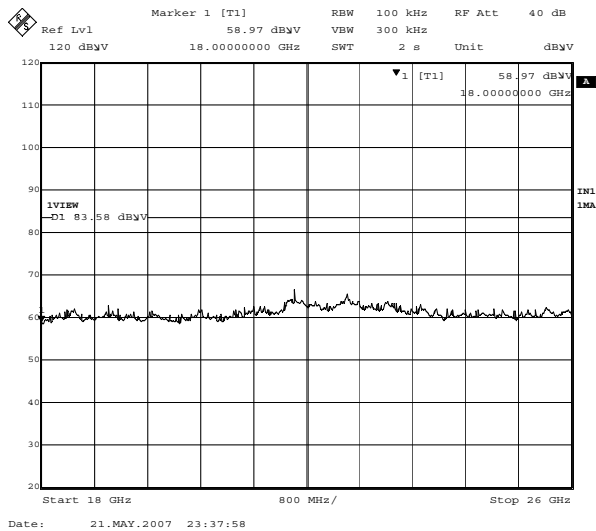

Out of Band Emission(Antenna Terminal Conducted): FCC 15.247(d)

COMPANY : RICOH COMPANY, LTD
EQUIPMENT : Option(s) for Radiocommunications
MODEL NUMBER : R-WL54MN
SERIAL NUMBER : 704S0191
FCC ID : BBP-WLRWL541
POWER : AC120V/60Hz

UL Japan, Inc. Yamakita No.2 Shielded Room
REPORT NO : 27IE0337-YK-A
REGULATION : Fcc Part15SubpartC 247(d)
DATE : 2007/05/22
TEMP./HUMI : 24deg.C./53%
Test Mode : Transmitting/Receiving
ENGINEER : Tatsuya Arai

[IEEE802.11g (54Mbps)]
Receiving (Ant1) Ch:2437MHz

1.

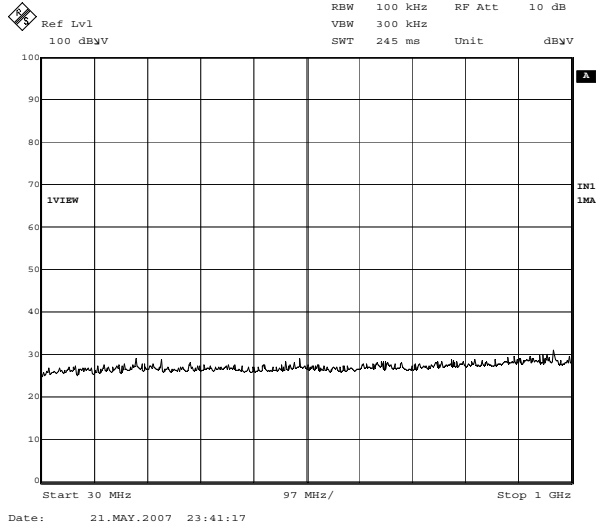

2.

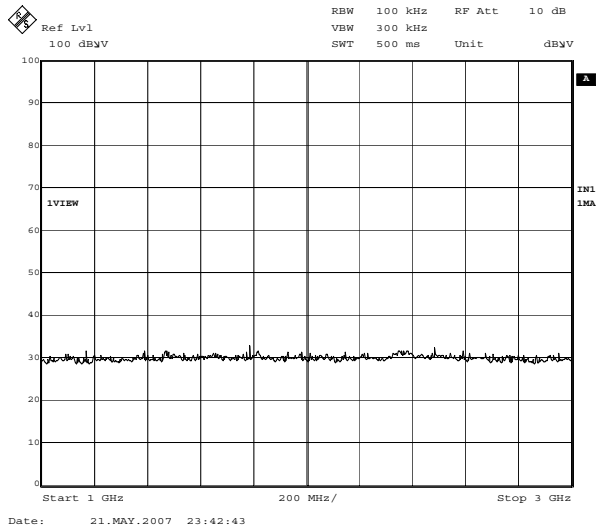

3.

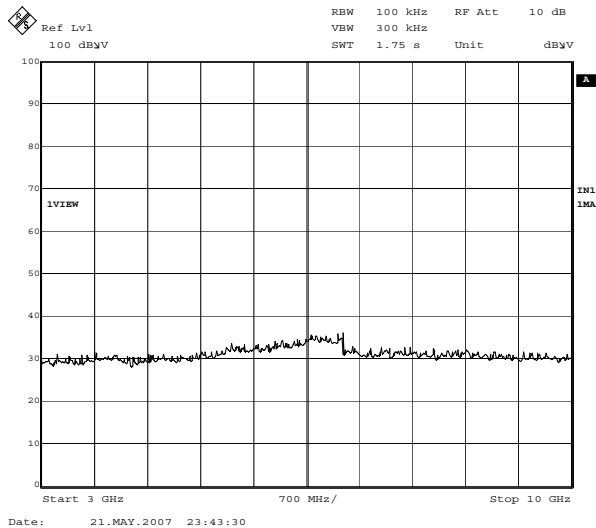

Out of Band Emission(Antenna Terminal Conducted): FCC 15.247(d)

COMPANY : RICOH COMPANY, LTD
EQUIPMENT : Option(s) for Radiocommunications
MODEL NUMBER : R-WL54MN
SERIAL NUMBER : 704S0191
FCC ID : BBP-WLRWL541
POWER : AC120V/60Hz

UL Japan, Inc. Yamakita No.2 Shielded Room
REPORT NO : 27IE0337-YK-A
REGULATION : Fcc Part15SubpartC 247(d)
DATE : 2007/05/22
TEMP./HUMI : 24deg.C./53%
Test Mode : Transmitting/Receiving
ENGINEER : Tatsuya Arai

[IEEE802.11g (54Mbps)]
Receiving (Ant2) Ch:2437MHz

1.

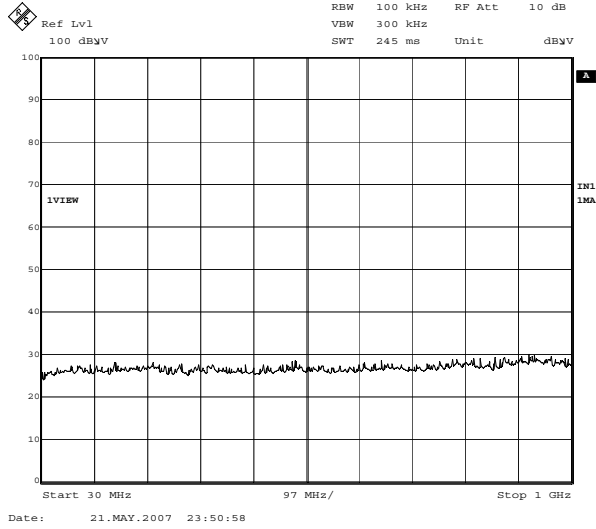

2.

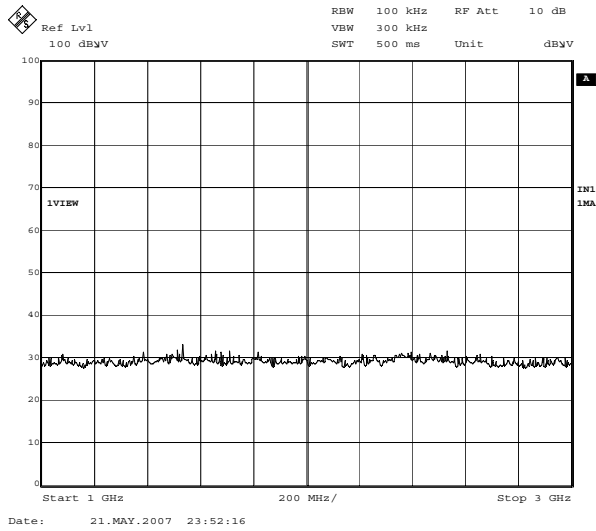

3.

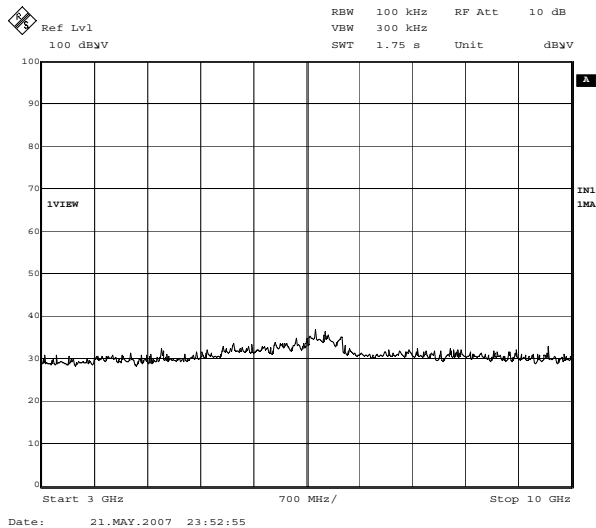

DATA OF RADIATION TEST

UL Japan, Inc.
YAMAKITA No.1 ANECHOIC CHAMBER
Report No. : 271E0337-YK-A

Applicant : RICOH COMPANY, LTD.
 Kind of Equipment : Option(s) for Radiocommunications
 Model No. : R-WL54MN
 Serial No. : 704S0191
 Power : AC120V/60Hz
 Mode : Transmitting (2412MHz)
 Remarks : IEEE802.11b
 Date : 5/14/2007
 Test Distance : 3 m
 Temperature : 22 °C
 Humidity : 48 %
 Regulation : FCC Part15C § 15.209

Engineer : Toyokazu Imamura

No.	FREQ. [MHz]	ANT TYPE	READING		ANT FACTOR [dB/m]	AMP GAIN [dB]	CABLE LOSS [dB]	ATTEN. [dB]	RESULT		LIMITS [dB μ V/m]	MARGIN	
			HOR [dB μ V]	VER					HOR [dB μ V/m]	VER		HOR [dB]	VER
1.	80.00	BB	46.9	45.0	6.6	28.6	1.8	5.8	32.5	30.6	40.0	7.5	9.4
2.	156.37	BB	45.3	36.3	15.1	28.2	2.6	5.8	40.6	31.6	43.5	2.9	11.9
3.	180.00	BB	42.0	33.9	16.5	28.1	2.8	5.8	39.0	30.9	43.5	4.5	12.6
4.	200.00	BB	40.6	30.8	16.9	27.9	2.9	5.8	38.3	28.5	43.5	5.2	15.0
5.	240.00	BB	41.3	31.2	17.5	27.7	3.3	5.8	40.2	30.1	46.0	5.8	15.9
6.	320.00	BB	42.9	35.8	14.8	27.6	3.9	5.9	39.9	32.8	46.0	6.1	13.2
7.	360.00	BB	37.4	31.9	15.9	28.0	4.3	5.9	35.5	30.0	46.0	10.5	16.0
8.	600.00	BB	31.4	31.7	19.8	29.2	5.5	5.9	33.4	33.7	46.0	12.6	12.3
9.	840.00	BB	29.8	26.5	21.5	28.9	6.5	5.9	34.8	31.5	46.0	11.2	14.5

CALCULATION: READING + ANT. FACTOR + CABLE LOSS - AMP. GAIN + ATTEN.

■ ANTENNA : KBA-03 (BBA9106) 30-299.99MHz / KLA-03 (USLP9143) 300-1000MHz
 ■ CABLE : KCC-30/31/32/34 ■ PREAMP : KAF-05 (8447D) ■ EMI RECEIVER : KTR-01 (ES140)

DATA OF RADIATION TEST

UL Japan, Inc.
YAMAKITA No.1 ANECHOIC CHAMBER
Report No. : 271E0337-YK-A

Applicant : RICOH COMPANY, LTD.
 Kind of Equipment : Option(s) for Radiocommunications
 Model No. : R-WL54MN
 Serial No. : 704S0191
 Power : AC120V/60Hz
 Mode : Transmitting(2437MHz)
 Remarks : IEEE802.11b
 Date : 5/14/2007
 Test Distance : 3 m
 Temperature : 22 °C
 Humidity : 48 %
 Regulation : FCC Part15C § 15.209

Engineer : Toyokazu Imamura

No.	FREQ. [MHz]	ANT TYPE	READING		ANT FACTOR [dB/m]	AMP GAIN [dB]	CABLE LOSS [dB]	ATTEN. [dB]	RESULT		LIMITS [dB μ V/m]	MARGIN	
			HOR [dB μ V]	VER					HOR [dB μ V/m]	VER		HOR [dB]	VER
1.	80.00	BB	46.7	44.8	6.6	28.6	1.8	5.8	32.3	30.4	40.0	7.7	9.6
2.	156.68	BB	45.4	36.6	15.1	28.2	2.6	5.8	40.7	31.9	43.5	2.8	11.6
3.	180.00	BB	40.8	30.0	16.5	28.1	2.8	5.8	37.8	27.0	43.5	5.7	16.5
4.	200.00	BB	40.2	31.9	16.9	27.9	2.9	5.8	37.9	29.6	43.5	5.6	13.9
5.	240.00	BB	41.1	31.5	17.5	27.7	3.3	5.8	40.0	30.4	46.0	6.0	15.6
6.	320.00	BB	40.7	33.9	14.8	27.6	3.9	5.9	37.7	30.9	46.0	8.3	15.1
7.	360.00	BB	36.8	32.0	15.9	28.0	4.3	5.9	34.9	30.1	46.0	11.1	15.9
8.	600.00	BB	31.5	32.0	19.8	29.2	5.5	5.9	33.5	34.0	46.0	12.5	12.0
9.	840.00	BB	29.5	26.6	21.5	28.9	6.5	5.9	34.5	31.6	46.0	11.5	14.4

CALCULATION: READING + ANT. FACTOR + CABLE LOSS - AMP. GAIN + ATTEN.

■ ANTENNA : KBA-03 (BBA9106) 30-299.99MHz/KLA-03 (USLP9143) 300-1000MHz
 ■ CABLE : KCC-30/31/32/34 ■ PREAMP : KAF-05 (8447D) ■ EMI RECEIVER : KTR-01 (ES140)

DATA OF RADIATION TEST

UL Japan, Inc.
YAMAKITA No.1 ANECHOIC CHAMBER
Report No. : 271E0337-YK-A

Applicant : RICOH COMPANY, LTD.
 Kind of Equipment : Option(s) for Radiocommunications
 Model No. : R-WL54MN
 Serial No. : 704S0191
 Power : AC120V/60Hz
 Mode : Transmitting(2462MHz)
 Remarks : IEEE802.11b
 Date : 5/14/2007
 Test Distance : 3 m
 Temperature : 22 °C
 Humidity : 48 %
 Regulation : FCC Part15C § 15.209

Engineer : Toyokazu Imamura

No.	FREQ. [MHz]	ANT TYPE	READING		ANT FACTOR [dB/m]	AMP GAIN [dB]	CABLE LOSS [dB]	ATTEN. [dB]	RESULT		LIMITS [dB μ V/m]	MARGIN	
			HOR [dB μ V]	VER					HOR [dB μ V/m]	VER		HOR [dB]	VER
1.	80.00	BB	47.0	45.1	6.6	28.6	1.8	5.8	32.6	30.7	40.0	7.4	9.3
2.	156.57	BB	45.7	36.7	15.1	28.2	2.6	5.8	41.0	32.0	43.5	2.5	11.5
3.	180.00	BB	40.5	29.3	16.5	28.1	2.8	5.8	37.5	26.3	43.5	6.0	17.2
4.	200.00	BB	41.4	32.2	16.9	27.9	2.9	5.8	39.1	29.9	43.5	4.4	13.6
5.	240.00	BB	41.3	31.6	17.5	27.7	3.3	5.8	40.2	30.5	46.0	5.8	15.5
6.	320.00	BB	41.4	34.4	14.8	27.6	3.9	5.9	38.4	31.4	46.0	7.6	14.6
7.	360.00	BB	37.0	32.0	15.9	28.0	4.3	5.9	35.1	30.1	46.0	10.9	15.9
8.	600.00	BB	31.4	31.0	19.8	29.2	5.5	5.9	33.4	33.0	46.0	12.6	13.0
9.	840.00	BB	29.8	26.3	21.5	28.9	6.5	5.9	34.8	31.3	46.0	11.2	14.7

CALCULATION: READING + ANT. FACTOR + CABLE LOSS - AMP. GAIN + ATTEN.

■ ANTENNA : KBA-03 (BBA9106) 30-299.99MHz/KLA-03 (USLP9143) 300-1000MHz
 ■ CABLE : KCC-30/31/32/34 ■ PREAMP : KAF-05 (8447D) ■ EMI RECEIVER : KTR-01 (ES140)

DATA OF RADIATION TEST

UL Japan, Inc.
YAMAKITA No.1 ANECHOIC CHAMBER
Report No. : 271E0337-YK-A

Applicant : RICOH COMPANY, LTD.
 Kind of Equipment : Option(s) for Radiocommunications
 Model No. : R-WL54MN
 Serial No. : 704S0191
 Power : AC120V/60Hz
 Mode : Transmitting (2412MHz)
 Remarks : IEEE802. 11b, PK (RBW: 1MHz, VBW: 1MHz)
 Date : 5/16/2007
 Test Distance : 3 m
 Temperature : 21 °C Engineer : Takahiro Suzuki
 Humidity : 47 %
 Regulation : FCC Part15C § 15. 209 (PK Detection)

No.	FREQ. [MHz]	ANT TYPE	READING		ANT FACTOR [dB/m]	AMP GAIN [dB]	CABLE LOSS [dB]	ATTEN. [dB]	RESULT		LIMITS [dB μ V/m]	MARGIN	
			HOR [dB μ V]	VER					HOR [dB μ V/m]	VER		HOR [dB]	VER
1.	1591.97	BB	45.9	48.2	26.4	35.8	2.9	10.1	49.5	51.8	74.0	24.5	22.2
2.	2390.00	BB	47.9	48.4	29.8	35.5	3.4	10.3	55.9	56.4	74.0	18.1	17.6
3.	4824.00	BB	45.9	48.3	33.8	34.6	5.4	0.7	51.2	53.6	74.0	22.8	20.4
4.	7236.00	BB	41.9	43.3	37.5	35.3	6.1	0.1	50.3	51.7	74.0	23.7	22.3
5.	9648.00	BB	45.8	46.4	38.9	35.9	7.9	0.6	57.3	57.9	74.0	16.7	16.1
6.	12060.00	BB	45.3	46.2	40.6	35.5	8.6	0.5	59.5	60.4	74.0	14.5	13.6

CALCULATION: READING + ANT. FACTOR + CABLE LOSS - AMP. GAIN + ATTEN.

■ ANTENNA: KHA-01 (SAS-200 571) 1-18GHz/KHA-06 (3116) 18-26GHz
 ■ CABLE: KCC-D16/D17 ■ AMP: APPRA05 (8449B) ■ SPECTRUMANALYZER: R3271A (KSA-04)

DATA OF RADIATION TEST

UL Japan, Inc.
YAMAKITA No.1 ANECHOIC CHAMBER
Report No. : 271E0337-YK-A

Applicant : RICOH COMPANY, LTD.
 Kind of Equipment : Option(s) for Radiocommunications
 Model No. : R-WL54MN
 Serial No. : 704S0191
 Power : AC120V/60Hz
 Mode : Transmitting (2412MHz)
 Remarks : IEEE802.11b, AV (RBW:1MHz, VBW:10Hz)
 Date : 5/16/2007
 Test Distance : 3 m
 Temperature : 21 °C Engineer : Takahiro Suzuki
 Humidity : 47 %
 Regulation : FCC Part15C § 15.209 (AV Detection)

No.	FREQ. [MHz]	ANT TYPE	READING		ANT FACTOR [dB/m]	AMP GAIN [dB]	CABLE LOSS [dB]	ATTEN. [dB]	RESULT		LIMITS [dB μ V/m]	MARGIN	
			HOR [dB μ V]	VER					HOR [dB μ V/m]	VER		HOR [dB]	VER
1.	1591.97	BB	34.6	35.4	26.4	35.8	2.9	10.1	38.2	39.0	54.0	15.8	15.0
2.	2390.00	BB	38.5	37.9	29.8	35.5	3.4	10.3	46.5	45.9	54.0	7.5	8.1
3.	4824.00	BB	33.3	35.2	33.8	34.6	5.4	0.7	38.6	40.5	54.0	15.4	13.5
4.	7236.00	BB	31.6	31.5	37.5	35.3	6.1	0.1	40.0	39.9	54.0	14.0	14.1
5.	9648.00	BB	35.8	35.7	38.9	35.9	7.9	0.6	47.3	47.2	54.0	6.7	6.8
6.	12060.00	BB	35.3	34.9	40.6	35.5	8.6	0.5	49.5	49.1	54.0	4.5	4.9

CALCULATION: READING + ANT. FACTOR + CABLE LOSS - AMP. GAIN + ATTEN.

■ ANTENNA: KHA-01 (SAS-200 571) 1-18GHz/KHA-06 (3116) 18-26GHz
 ■ CABLE: KCC-D16/D17 ■ AMP: APPRA05 (8449B) ■ SPECTRUMANALYZER: R3271A (KSA-04)

DATA OF RADIATION TEST

UL Japan, Inc.
YAMAKITA No.1 ANECHOIC CHAMBER
Report No. : 271E0337-YK-A

Applicant : RICOH COMPANY, LTD.
 Kind of Equipment : Option(s) for Radiocommunications
 Model No. : R-WL54MN
 Serial No. : 704S0191
 Power : AC120V/60Hz
 Mode : Transmitting (2437MHz)
 Remarks : IEEE802.11b, PK (RBW:1MHz, VBW:1MHz)
 Date : 5/16/2007
 Test Distance : 3 m
 Temperature : 21 °C Engineer : Takahiro Suzuki
 Humidity : 47 %
 Regulation : FCC Part15C § 15.209 (PK Detection)

No.	FREQ. [MHz]	ANT TYPE	READING		ANT FACTOR [dB/m]	AMP GAIN [dB]	CABLE LOSS [dB]	ATTEN. [dB]	RESULT		LIMITS [dB μ V/m]	MARGIN	
			HOR [dB μ V]	VER					HOR [dB μ V/m]	VER		HOR [dB]	VER
1.	1591.97	BB	46.9	47.9	26.4	35.8	2.9	10.1	50.5	51.5	74.0	23.5	22.5
2.	4874.00	BB	47.9	41.2	34.0	34.6	5.4	0.7	53.4	46.7	74.0	20.6	27.3
3.	7311.00	BB	42.1	41.7	37.6	35.3	6.1	0.1	50.6	50.2	74.0	23.4	23.8
4.	9748.00	BB	46.1	45.3	38.8	35.9	7.8	0.6	57.4	56.6	74.0	16.6	17.4
5.	12185.00	BB	44.5	44.7	40.6	35.4	8.8	0.4	58.9	59.1	74.0	15.1	14.9

CALCULATION: READING + ANT.FACTOR + CABLE LOSS - AMP.GAIN + ATTEN.

■ ANTENNA: KHA-01 (SAS-200 571) 1-18GHz/KHA-06 (3116) 18-26GHz
 ■ CABLE: KCC-D16/D17 ■ AMP: APPRA05 (8449B) ■ SPECTRUMANALYZER: R3271A (KSA-04)

DATA OF RADIATION TEST

UL Japan, Inc.
YAMAKITA No.1 ANECHOIC CHAMBER
Report No. : 271E0337-YK-A

Applicant : RICOH COMPANY, LTD.
 Kind of Equipment : Option(s) for Radiocommunications
 Model No. : R-WL54MN
 Serial No. : 704S0191
 Power : AC120V/60Hz
 Mode : Transmitting (2437MHz)
 Remarks : IEEE802.11b, AV (RBW:1MHz, VBW:10Hz)
 Date : 5/16/2007
 Test Distance : 3 m
 Temperature : 21 °C Engineer : Takahiro Suzuki
 Humidity : 47 %
 Regulation : FCC Part15C § 15.209 (AV Detection)

No.	FREQ. [MHz]	ANT TYPE	READING		ANT FACTOR [dB/m]	AMP GAIN [dB]	CABLE LOSS [dB]	ATTEN. [dB]	RESULT		LIMITS [dB μ V/m]	MARGIN	
			HOR [dB μ V]	VER					HOR [dB μ V/m]	VER		HOR [dB]	VER
1.	1591.97	BB	34.6	35.3	26.4	35.8	2.9	10.1	38.2	38.9	54.0	15.8	15.1
2.	4874.00	BB	34.5	32.1	34.0	34.6	5.4	0.7	40.0	37.6	54.0	14.0	16.4
3.	7311.00	BB	31.7	30.9	37.6	35.3	6.1	0.1	40.2	39.4	54.0	13.8	14.6
4.	9748.00	BB	35.6	35.8	38.8	35.9	7.8	0.6	46.9	47.1	54.0	7.1	6.9
5.	12185.00	BB	35.1	35.3	40.6	35.4	8.8	0.4	49.5	49.7	54.0	4.5	4.3

CALCULATION: READING + ANT.FACTOR + CABLE LOSS - AMP.GAIN + ATTEN.

■ ANTENNA: KHA-01 (SAS-200 571) 1-18GHz/KHA-06 (3116) 18-26GHz
 ■ CABLE: KCC-D16/D17 ■ AMP: APPRA05 (8449B) ■ SPECTRUMANALYZER: R3271A (KSA-04)

DATA OF RADIATION TEST

UL Japan, Inc.
YAMAKITA No.1 ANECHOIC CHAMBER
Report No. : 271E0337-YK-A

Applicant : RICOH COMPANY, LTD.
 Kind of Equipment : Option(s) for Radiocommunications
 Model No. : R-WL54MN
 Serial No. : 704S0191
 Power : AC120V/60Hz
 Mode : Transmitting (2462MHz)
 Remarks : IEEE802.11b, PK (RBW:1MHz, VBW:1MHz)
 Date : 5/16/2007
 Test Distance : 3 m
 Temperature : 21 °C Engineer : Takahiro Suzuki
 Humidity : 47 %
 Regulation : FCC Part15C § 15.209 (PK Detection)

No.	FREQ. [MHz]	ANT TYPE	READING		ANT FACTOR [dB/m]	AMP GAIN [dB]	CABLE LOSS [dB]	ATTEN. [dB]	RESULT		LIMITS [dB μ V/m]	MARGIN	
			HOR [dB μ V]	VER					HOR [dB μ V/m]	VER		HOR [dB]	VER
1.	1588.94	BB	45.8	49.2	26.4	35.8	2.9	10.1	49.4	52.8	74.0	24.6	21.2
2.	2483.50	BB	50.1	49.8	29.7	35.5	3.4	10.4	58.1	57.8	74.0	15.9	16.2
3.	4924.00	BB	43.9	43.8	34.1	34.6	5.4	0.7	49.5	49.4	74.0	24.5	24.6
4.	7386.00	BB	40.5	39.6	37.7	35.3	6.1	0.1	49.1	48.2	74.0	24.9	25.8
5.	9848.00	BB	48.1	45.8	38.8	35.9	7.6	0.6	59.2	56.9	74.0	14.8	17.1
6.	12310.00	BB	45.3	45.2	40.5	35.3	9.0	0.4	59.9	59.8	74.0	14.1	14.2

CALCULATION: READING + ANT. FACTOR + CABLE LOSS - AMP. GAIN + ATTEN.

■ ANTENNA: KHA-01 (SAS-200 571) 1-18GHz/KHA-06 (3116) 18-26GHz
 ■ CABLE: KCC-D16/D17 ■ AMP: APPRA05 (8449B) ■ SPECTRUMANALYZER: R3271A (KSA-04)

DATA OF RADIATION TEST

UL Japan, Inc.
YAMAKITA No.1 ANECHOIC CHAMBER
Report No. : 271E0337-YK-A

Applicant : RICOH COMPANY, LTD.
 Kind of Equipment : Option(s) for Radiocommunications
 Model No. : R-WL54MN
 Serial No. : 704S0191
 Power : AC120V/60Hz
 Mode : Transmitting(2462MHz)
 Remarks : IEEE802.11b, AV (RBW:1MHz, VBW:10Hz)
 Date : 5/16/2007
 Test Distance : 3 m
 Temperature : 21 °C Engineer : Takahiro Suzuki
 Humidity : 47 %
 Regulation : FCC Part15C § 15.209(AV Detection)

No.	FREQ. [MHz]	ANT TYPE	READING		ANT FACTOR [dB/m]	AMP GAIN [dB]	CABLE LOSS [dB]	ATTEN. [dB]	RESULT		LIMITS [dB μ V/m]	MARGIN	
			HOR [dB μ V]	VER					HOR [dB μ V/m]	VER		HOR [dB]	VER
1.	1588.94	BB	34.3	35.2	26.4	35.8	2.9	10.1	37.9	38.8	54.0	16.1	15.2
2.	2483.50	BB	42.3	41.1	29.7	35.5	3.4	10.4	50.3	49.1	54.0	3.7	4.9
3.	4924.00	BB	32.8	32.3	34.1	34.6	5.4	0.7	38.4	37.9	54.0	15.6	16.1
4.	7386.00	BB	31.2	31.6	37.7	35.3	6.1	0.1	39.8	40.2	54.0	14.2	13.8
5.	9848.00	BB	36.3	36.3	38.8	35.9	7.6	0.6	47.4	47.4	54.0	6.6	6.6
6.	12310.00	BB	34.9	34.8	40.5	35.3	9.0	0.4	49.5	49.4	54.0	4.5	4.6

CALCULATION: READING + ANT. FACTOR + CABLE LOSS - AMP. GAIN + ATTEN.

■ ANTENNA: KHA-01 (SAS-200 571) 1-18GHz/KHA-06 (3116) 18-26GHz
 ■ CABLE: KCC-D16/D17 ■ AMP: APPRA05 (8449B) ■ SPECTRUMANALYZER: R3271A (KSA-04)

DATA OF RADIATION TEST

UL Japan, Inc.
YAMAKITA No.1 ANECHOIC CHAMBER
Report No. : 271E0337-YK-A

Applicant : RICOH COMPANY, LTD.
 Kind of Equipment : Option(s) for Radiocommunications
 Model No. : R-WL54MN
 Serial No. : 704S0191
 Power : AC120V/60Hz
 Mode : Transmitting (2412MHz)
 Remarks : IEEE802.11g
 Date : 5/14/2007
 Test Distance : 3 m
 Temperature : 22 °C
 Humidity : 48 %
 Regulation : FCC Part15C § 15.209

Engineer : Toyokazu Imamura

No.	FREQ. [MHz]	ANT TYPE	READING		ANT FACTOR [dB/m]	AMP GAIN [dB]	CABLE LOSS [dB]	ATTEN. [dB]	RESULT		LIMITS [dB μ V/m]	MARGIN	
			HOR [dB μ V]	VER					HOR [dB μ V/m]	VER		HOR [dB]	VER
1.	80.00	BB	46.1	44.6	6.6	28.6	1.8	5.8	31.7	30.2	40.0	8.3	9.8
2.	156.57	BB	45.3	36.3	15.1	28.2	2.6	5.8	40.6	31.6	43.5	2.9	11.9
3.	180.00	BB	40.5	30.0	16.5	28.1	2.8	5.8	37.5	27.0	43.5	6.0	16.5
4.	200.00	BB	38.4	30.1	16.9	27.9	2.9	5.8	36.1	27.8	43.5	7.4	15.7
5.	240.00	BB	41.0	31.1	17.5	27.7	3.3	5.8	39.9	30.0	46.0	6.1	16.0
6.	320.00	BB	41.4	34.0	14.8	27.6	3.9	5.9	38.4	31.0	46.0	7.6	15.0
7.	360.00	BB	36.8	32.3	15.9	28.0	4.3	5.9	34.9	30.4	46.0	11.1	15.6
8.	600.00	BB	31.4	31.8	19.8	29.2	5.5	5.9	33.4	33.8	46.0	12.6	12.2
9.	840.00	BB	29.7	26.9	21.5	28.9	6.5	5.9	34.7	31.9	46.0	11.3	14.1

CALCULATION: READING + ANT. FACTOR + CABLE LOSS - AMP. GAIN + ATTEN.

■ ANTENNA : KBA-03 (BBA9106) 30-299.99MHz / KLA-03 (USLP9143) 300-1000MHz
 ■ CABLE : KCC-30/31/32/34 ■ PREAMP : KAF-05 (8447D) ■ EMI RECEIVER : KTR-01 (ES140)

DATA OF RADIATION TEST

UL Japan, Inc.
YAMAKITA No.1 ANECHOIC CHAMBER
Report No. : 271E0337-YK-A

Applicant : RICOH COMPANY, LTD.
 Kind of Equipment : Option(s) for Radiocommunications
 Model No. : R-WL54MN
 Serial No. : 704S0191
 Power : AC120V/60Hz
 Mode : Transmitting (2437MHz)
 Remarks : IEEE802.11g
 Date : 5/14/2007
 Test Distance : 3 m
 Temperature : 22 °C
 Humidity : 48 %
 Regulation : FCC Part15C § 15.209

Engineer : Toyokazu Imamura

No.	FREQ. [MHz]	ANT TYPE	READING		ANT FACTOR [dB/m]	AMP GAIN [dB]	CABLE LOSS [dB]	ATTEN. [dB]	RESULT		LIMITS [dB μ V/m]	MARGIN	
			HOR [dB μ V]	VER					HOR [dB μ V/m]	VER		HOR [dB]	VER
1.	80.00	BB	46.3	44.8	6.6	28.6	1.8	5.8	31.9	30.4	40.0	8.1	9.6
2.	156.57	BB	45.2	36.2	15.1	28.2	2.6	5.8	40.5	31.5	43.5	3.0	12.0
3.	180.00	BB	40.8	30.3	16.5	28.1	2.8	5.8	37.8	27.3	43.5	5.7	16.2
4.	200.00	BB	38.4	29.7	16.9	27.9	2.9	5.8	36.1	27.4	43.5	7.4	16.1
5.	240.00	BB	41.0	31.2	17.5	27.7	3.3	5.8	39.9	30.1	46.0	6.1	15.9
6.	320.00	BB	40.8	33.4	14.8	27.6	3.9	5.9	37.8	30.4	46.0	8.2	15.6
7.	360.00	BB	36.7	32.5	15.9	28.0	4.3	5.9	34.8	30.6	46.0	11.2	15.4
8.	600.00	BB	31.4	32.3	19.8	29.2	5.5	5.9	33.4	34.3	46.0	12.6	11.7
9.	840.00	BB	29.4	26.9	21.5	28.9	6.5	5.9	34.4	31.9	46.0	11.6	14.1

CALCULATION: READING + ANT. FACTOR + CABLE LOSS - AMP. GAIN + ATTEN.

■ ANTENNA : KBA-03 (BBA9106) 30-299.99MHz / KLA-03 (USLP9143) 300-1000MHz
 ■ CABLE : KCC-30/31/32/34 ■ PREAMP : KAF-05 (8447D) ■ EMI RECEIVER : KTR-01 (ES140)

DATA OF RADIATION TEST

UL Japan, Inc.
YAMAKITA No.1 ANECHOIC CHAMBER
Report No. : 271E0337-YK-A

Applicant : RICOH COMPANY, LTD.
 Kind of Equipment : Option(s) for Radiocommunications
 Model No. : R-WL54MN
 Serial No. : 704S0191
 Power : AC120V/60Hz
 Mode : Transmitting(2462MHz)
 Remarks : IEEE802.11g
 Date : 5/14/2007
 Test Distance : 3 m
 Temperature : 22 °C
 Humidity : 48 %
 Regulation : FCC Part15C § 15.209

Engineer : Toyokazu Imamura

No.	FREQ. [MHz]	ANT TYPE	READING		ANT FACTOR [dB/m]	AMP GAIN [dB]	CABLE LOSS [dB]	ATTEN. [dB]	RESULT		LIMITS [dB μ V/m]	MARGIN	
			HOR [dB μ V]	VER					HOR [dB μ V/m]	VER		HOR [dB]	VER
1.	80.00	BB	46.3	45.0	6.6	28.6	1.8	5.8	31.9	30.6	40.0	8.1	9.4
2.	156.37	BB	45.1	35.7	15.1	28.2	2.6	5.8	40.4	31.0	43.5	3.1	12.5
3.	180.00	BB	40.9	30.0	16.5	28.1	2.8	5.8	37.9	27.0	43.5	5.6	16.5
4.	200.00	BB	38.5	29.8	16.9	27.9	2.9	5.8	36.2	27.5	43.5	7.3	16.0
5.	240.00	BB	40.6	31.7	17.5	27.7	3.3	5.8	39.5	30.6	46.0	6.5	15.4
6.	320.00	BB	40.9	33.3	14.8	27.6	3.9	5.9	37.9	30.3	46.0	8.1	15.7
7.	360.00	BB	36.8	32.4	15.9	28.0	4.3	5.9	34.9	30.5	46.0	11.1	15.5
8.	600.00	BB	31.4	31.9	19.8	29.2	5.5	5.9	33.4	33.9	46.0	12.6	12.1
9.	840.00	BB	29.4	26.9	21.5	28.9	6.5	5.9	34.4	31.9	46.0	11.6	14.1

CALCULATION: READING + ANT. FACTOR + CABLE LOSS - AMP. GAIN + ATTEN.

■ ANTENNA : KBA-03 (BBA9106) 30-299.99MHz/KLA-03 (USLP9143) 300-1000MHz
 ■ CABLE : KCC-30/31/32/34 ■ PREAMP : KAF-05 (8447D) ■ EMI RECEIVER : KTR-01 (ES140)

DATA OF RADIATION TEST

UL Japan, Inc.
YAMAKITA No.1 ANECHOIC CHAMBER
Report No. : 271E0337-YK-A

Applicant : RICOH COMPANY, LTD.
 Kind of Equipment : Option(s) for Radiocommunications
 Model No. : R-WL54MN
 Serial No. : 704S0191
 Power : AC120V/60Hz
 Mode : Transmitting (2412MHz)
 Remarks : IEEE802. 11g, PK (RBW: 1MHz, VBW: 1MHz)
 Date : 5/16/2007
 Test Distance : 3 m
 Temperature : 21 °C Engineer : Takahiro Suzuki
 Humidity : 47 %
 Regulation : FCC Part15C § 15. 209 (PK Detection)

No.	FREQ. [MHz]	ANT TYPE	READING		ANT FACTOR [dB/m]	AMP GAIN [dB]	CABLE LOSS [dB]	ATTEN. [dB]	RESULT		LIMITS [dB μ V/m]	MARGIN	
			HOR [dB μ V]	VER					HOR [dB μ V/m]	VER		HOR [dB]	VER
1.	1589.89	BB	44.9	48.5	26.4	35.8	2.9	10.1	48.5	52.1	74.0	25.5	21.9
2.	2390.00	BB	51.2	49.8	29.8	35.5	3.4	10.3	59.2	57.8	74.0	14.8	16.2
3.	4824.00	BB	43.2	44.3	33.8	34.6	5.4	0.7	48.5	49.6	74.0	25.5	24.4
4.	7236.00	BB	41.4	41.1	37.5	35.3	6.1	0.1	49.8	49.5	74.0	24.2	24.5
5.	9648.00	BB	45.2	44.9	38.9	35.9	7.9	0.6	56.7	56.4	74.0	17.3	17.6
6.	12060.00	BB	45.5	44.8	40.6	35.5	8.6	0.5	59.7	59.0	74.0	14.3	15.0

CALCULATION: READING + ANT. FACTOR + CABLE LOSS - AMP. GAIN + ATTEN.

■ ANTENNA: KHA-01 (SAS-200 571) 1-18GHz/KHA-06 (3116) 18-26GHz
 ■ CABLE: KCC-D16/D17 ■ AMP: APPRA05 (8449B) ■ SPECTRUMANALYZER: R3271A (KSA-04)

DATA OF RADIATION TEST

UL Japan, Inc.
YAMAKITA No.1 ANECHOIC CHAMBER
Report No. : 271E0337-YK-A

Applicant : RICOH COMPANY, LTD.
 Kind of Equipment : Option(s) for Radiocommunications
 Model No. : R-WL54MN
 Serial No. : 704S0191
 Power : AC120V/60Hz
 Mode : Transmitting (2412MHz)
 Remarks : IEEE802. 11g, AV (RBW:1MHz, VBW:10Hz)
 Date : 5/16/2007
 Test Distance : 3 m
 Temperature : 21 °C Engineer : Takahiro Suzuki
 Humidity : 47 %
 Regulation : FCC Part15C § 15.209 (AV Detection)

No.	FREQ. [MHz]	ANT TYPE	READING		ANT FACTOR [dB/m]	AMP GAIN [dB]	CABLE LOSS [dB]	ATTEN. [dB]	RESULT		LIMITS [dB μ V/m]	MARGIN	
			HOR [dB μ V]	VER					HOR [dB μ V/m]	VER		HOR [dB]	VER
1.	1589.89	BB	34.3	35.2	26.4	35.8	2.9	10.1	37.9	38.8	54.0	16.1	15.2
2.	2390.00	BB	37.6	37.7	29.8	35.5	3.4	10.3	45.6	45.7	54.0	8.4	8.3
3.	4824.00	BB	32.2	32.6	33.8	34.6	5.4	0.7	37.5	37.9	54.0	16.5	16.1
4.	7236.00	BB	31.5	32.3	37.5	35.3	6.1	0.1	39.9	40.7	54.0	14.1	13.3
5.	9648.00	BB	35.3	35.6	38.9	35.9	7.9	0.6	46.8	47.1	54.0	7.2	6.9
6.	12060.00	BB	34.8	35.2	40.6	35.5	8.6	0.5	49.0	49.4	54.0	5.0	4.6

CALCULATION: READING + ANT. FACTOR + CABLE LOSS - AMP. GAIN + ATTEN.

■ ANTENNA: KHA-01 (SAS-200 571) 1-18GHz/KHA-06 (3116) 18-26GHz
 ■ CABLE: KCC-D16/D17 ■ AMP: APPRA05 (8449B) ■ SPECTRUMANALYZER: R3271A (KSA-04)

DATA OF RADIATION TEST

UL Japan, Inc.
YAMAKITA No.1 ANECHOIC CHAMBER
Report No. : 271E0337-YK-A

Applicant : RICOH COMPANY, LTD.
Kind of Equipment : Option(s) for Radiocommunications
Model No. : R-WL54MN
Serial No. : 704S0191
Power : AC120V/60Hz
Mode : Transmitting (2437MHz)
Remarks : IEEE802.11g, PK (RBW:1MHz, VBW:1MHz)
Date : 5/16/2007
Test Distance : 3 m
Temperature : 21 °C Engineer : Takahiro Suzuki
Humidity : 47 %
Regulation : FCC Part15C § 15.209 (PK Detection)

No.	FREQ. [MHz]	ANT TYPE	READING		ANT FACTOR [dB/m]	AMP GAIN [dB]	CABLE LOSS [dB]	ATTEN. [dB]	RESULT		LIMITS [dB μ V/m]	MARGIN	
			HOR [dB μ V]	VER					HOR [dB μ V/m]	VER		HOR [dB]	VER
1.	1590.00	BB	44.9	46.2	26.4	35.8	2.9	10.1	48.5	49.8	74.0	25.5	24.2
2.	4874.00	BB	44.2	42.5	34.0	34.6	5.4	0.7	49.7	48.0	74.0	24.3	26.0
3.	7311.00	BB	41.6	40.9	37.6	35.3	6.1	0.1	50.1	49.4	74.0	23.9	24.6
4.	9748.00	BB	44.4	45.0	38.8	35.9	7.8	0.6	55.7	56.3	74.0	18.3	17.7
5.	12185.00	BB	44.7	44.3	40.6	35.4	8.8	0.4	59.1	58.7	74.0	14.9	15.3

CALCULATION: READING + ANT.FACTOR + CABLE LOSS - AMP.GAIN + ATTEN.

■ ANTENNA: KHA-01 (SAS-200 571) 1-18GHz/KHA-06 (3116) 18-26GHz
■ CABLE: KCC-D16/D17 ■ AMP: APPRA05 (8449B) ■ SPECTRUMANALYZER: R3271A (KSA-04)

DATA OF RADIATION TEST

UL Japan, Inc.
YAMAKITA No.1 ANECHOIC CHAMBER
Report No. : 271E0337-YK-A

Applicant : RICOH COMPANY, LTD.
 Kind of Equipment : Option(s) for Radiocommunications
 Model No. : R-WL54MN
 Serial No. : 704S0191
 Power : AC120V/60Hz
 Mode : Transmitting (2437MHz)
 Remarks : IEEE802. 11g, AV (RBW:1MHz, VBW:10Hz)
 Date : 5/16/2007
 Test Distance : 3 m
 Temperature : 21 °C Engineer : Takahiro Suzuki
 Humidity : 47 %
 Regulation : FCC Part15C § 15.209 (AV Detection)

No.	FREQ. [MHz]	ANT TYPE	READING		ANT FACTOR [dB/m]	AMP GAIN [dB]	CABLE LOSS [dB]	ATTEN. [dB]	RESULT		LIMITS [dB μ V/m]	MARGIN	
			HOR [dB μ V]	VER					HOR [dB μ V/m]	VER		HOR [dB]	VER
1.	1590.00	BB	34.0	35.1	26.4	35.8	2.9	10.1	37.6	38.7	54.0	16.4	15.3
2.	4874.00	BB	32.7	32.3	34.0	34.6	5.4	0.7	38.2	37.8	54.0	15.8	16.2
3.	7311.00	BB	31.7	32.6	37.6	35.3	6.1	0.1	40.2	41.1	54.0	13.8	12.9
4.	9748.00	BB	35.6	35.8	38.8	35.9	7.8	0.6	46.9	47.1	54.0	7.1	6.9
5.	12185.00	BB	34.9	35.1	40.6	35.4	8.8	0.4	49.3	49.5	54.0	4.7	4.5

CALCULATION: READING + ANT. FACTOR + CABLE LOSS - AMP. GAIN + ATTEN.

■ ANTENNA: KHA-01 (SAS-200 571) 1-18GHz/KHA-06 (3116) 18-26GHz
 ■ CABLE: KCC-D16/D17 ■ AMP: APPRA05 (8449B) ■ SPECTRUMANALYZER: R3271A (KSA-04)

DATA OF RADIATION TEST

UL Japan, Inc.
YAMAKITA No.1 ANECHOIC CHAMBER
Report No. : 271E0337-YK-A

Applicant : RICOH COMPANY, LTD.
 Kind of Equipment : Option(s) for Radiocommunications
 Model No. : R-WL54MN
 Serial No. : 704S0191
 Power : AC120V/60Hz
 Mode : Transmitting (2462MHz)
 Remarks : IEEE802. 11g, PK (RBW: 1MHz, VBW: 1MHz)
 Date : 5/16/2007
 Test Distance : 3 m
 Temperature : 21 °C Engineer : Takahiro Suzuki
 Humidity : 47 %
 Regulation : FCC Part15C § 15.209 (PK Detection)

No.	FREQ. [MHz]	ANT TYPE	READING		ANT FACTOR [dB/m]	AMP GAIN [dB]	CABLE LOSS [dB]	ATTEN. [dB]	RESULT		LIMITS [dB μ V/m]	MARGIN	
			HOR [dB μ V]	VER					HOR [dB μ V/m]	VER		HOR [dB]	VER
1.	1590.00	BB	46.7	48.2	26.4	35.8	2.9	10.1	50.3	51.8	74.0	23.7	22.2
2.	2483.50	BB	47.6	51.6	29.7	35.5	3.4	10.4	55.6	59.6	74.0	18.4	14.4
3.	4924.00	BB	41.4	42.4	34.1	34.6	5.4	0.7	47.0	48.0	74.0	27.0	26.0
4.	7386.00	BB	39.9	41.9	37.7	35.3	6.1	0.1	48.5	50.5	74.0	25.5	23.5
5.	9848.00	BB	45.9	46.1	38.8	35.9	7.6	0.6	57.0	57.2	74.0	17.0	16.8
6.	12310.00	BB	44.9	43.9	40.5	35.3	9.0	0.4	59.5	58.5	74.0	14.5	15.5

CALCULATION: READING + ANT. FACTOR + CABLE LOSS - AMP. GAIN + ATTEN.

■ ANTENNA: KHA-01 (SAS-200 571) 1-18GHz/KHA-06 (3116) 18-26GHz
 ■ CABLE: KCC-D16/D17 ■ AMP: APPRA05 (8449B) ■ SPECTRUMANALYZER: R3271A (KSA-04)

DATA OF RADIATION TEST

UL Japan, Inc.
YAMAKITA No.1 ANECHOIC CHAMBER
Report No. : 271E0337-YK-A

Applicant : RICOH COMPANY, LTD.
 Kind of Equipment : Option(s) for Radiocommunications
 Model No. : R-WL54MN
 Serial No. : 704S0191
 Power : AC120V/60Hz
 Mode : Transmitting(2462MHz)
 Remarks : IEEE802. 11g, AV (RBW:1MHz, VBW:10Hz)
 Date : 5/16/2007
 Test Distance : 3 m
 Temperature : 21 °C Engineer : Takahiro Suzuki
 Humidity : 47 %
 Regulation : FCC Part15C § 15.209(AV Detection)

No.	FREQ. [MHz]	ANT TYPE	READING		ANT FACTOR [dB/m]	AMP GAIN [dB]	CABLE LOSS [dB]	ATTEN. [dB]	RESULT		LIMITS [dB μ V/m]	MARGIN	
			HOR [dB μ V]	VER					HOR [dB μ V/m]	VER		HOR [dB]	VER
1.	1590.00	BB	34.8	35.2	26.4	35.8	2.9	10.1	38.4	38.8	54.0	15.6	15.2
2.	2483.50	BB	36.1	39.4	29.7	35.5	3.4	10.4	44.1	47.4	54.0	9.9	6.6
3.	4924.00	BB	32.1	31.8	34.1	34.6	5.4	0.7	37.7	37.4	54.0	16.3	16.6
4.	7386.00	BB	31.6	31.8	37.7	35.3	6.1	0.1	40.2	40.4	54.0	13.8	13.6
5.	9848.00	BB	36.3	36.0	38.8	35.9	7.6	0.6	47.4	47.1	54.0	6.6	6.9
6.	12310.00	BB	34.7	34.5	40.5	35.3	9.0	0.4	49.3	49.1	54.0	4.7	4.9

CALCULATION: READING + ANT. FACTOR + CABLE LOSS - AMP. GAIN + ATTEN.

■ ANTENNA: KHA-01 (SAS-200 571) 1-18GHz/KHA-06 (3116) 18-26GHz
 ■ CABLE: KCC-D16/D17 ■ AMP: APPRA05 (8449B) ■ SPECTRUMANALYZER: R3271A (KSA-04)

DATA OF RADIATION TEST

UL Japan, Inc.
YAMAKITA No.1 ANECHOIC CHAMBER
Report No. : 271E0337-YK-A

Applicant : RICOH COMPANY, LTD.
 Kind of Equipment : Option(s) for Radiocommunications
 Model No. : R-WL54MN
 Serial No. : 704S0191
 Power : AC120V/60Hz
 Mode : Receiving(2437MHz)
 Remarks : IEEE802.11b/g
 Date : 5/15/2007
 Test Distance : 3 m
 Temperature : 23 °C
 Humidity : 53 %
 Regulation : FCC Part15B § 15.109(a)

Engineer : Takahiro Suzuki

No.	FREQ. [MHz]	ANT TYPE	READING		ANT FACTOR [dB/m]	AMP GAIN [dB]	CABLE LOSS [dB]	ATTEN. [dB]	RESULT		LIMITS [dB μ V/m]	MARGIN	
			HOR [dB μ V]	VER					HOR [dB μ V/m]	VER		HOR [dB]	VER
1.	80.00	BB	46.3	47.3	6.6	28.6	1.8	5.8	31.9	32.9	40.0	8.1	7.1
2.	148.60	BB	46.5	42.1	14.8	28.3	2.5	5.8	41.3	36.9	43.5	2.2	6.6
3.	180.00	BB	40.1	30.6	16.5	28.1	2.8	5.8	37.1	27.6	43.5	6.4	15.9
4.	200.00	BB	42.5	33.4	16.9	27.9	2.9	5.8	40.2	31.1	43.5	3.3	12.4
5.	240.00	BB	40.3	30.6	17.5	27.7	3.3	5.8	39.2	29.5	46.0	6.8	16.5
6.	320.00	BB	43.1	33.8	14.8	27.6	3.9	5.9	40.1	30.8	46.0	5.9	15.2
7.	360.00	BB	37.3	31.9	15.9	28.0	4.3	5.9	35.4	30.0	46.0	10.6	16.0
8.	600.00	BB	34.6	32.3	19.8	29.2	5.5	5.9	36.6	34.3	46.0	9.4	11.7
9.	840.00	BB	30.7	25.5	21.5	28.9	6.5	5.9	35.7	30.5	46.0	10.3	15.5

CALCULATION: READING + ANT. FACTOR + CABLE LOSS - AMP. GAIN + ATTEN.

■ ANTENNA : KBA-03 (BBA9106) 30-299.99MHz / KLA-03 (USLP9143) 300-1000MHz
 ■ CABLE : KCC-30/31/32/34 ■ PREAMP : KAF-05 (8447D) ■ EMI RECEIVER : KTR-01 (ES140)

DATA OF RADIATION TEST

UL Japan, Inc.
YAMAKITA No.1 ANECHOIC CHAMBER
Report No. : 271E0337-YK-A

Applicant : RICOH COMPANY, LTD.
 Kind of Equipment : Option(s) for Radiocommunications
 Model No. : R-WL54MN
 Serial No. : 704S0191
 Power : AC120V/60Hz
 Mode : Receiving(2437MHz)
 Remarks : IEEE802.11b/g, PK (RBW:1MHz, VBW:1MHz)
 Date : 5/16/2007
 Test Distance : 3 m
 Temperature : 21 °C Engineer : Takahiro Suzuki
 Humidity : 47 %
 Regulation : FCC Part15B CLASS B (PK)

No.	FREQ. [MHz]	ANT TYPE	READING		ANT FACTOR [dB/m]	AMP GAIN [dB]	CABLE LOSS [dB]	ATTEN. [dB]	RESULT		LIMITS [dB μ V/m]	MARGIN	
			HOR [dB μ V]	VER					HOR [dB μ V/m]	VER		HOR [dB]	VER
1.	1715.31	BB	54.2	55.4	27.5	35.7	3.1	10.1	59.2	60.4	74.0	14.8	13.6
2.	2249.36	BB	50.3	49.7	29.9	35.5	3.5	10.2	58.4	57.8	74.0	15.6	16.2
3.	2437.00	BB	43.9	43.0	29.7	35.5	3.4	10.4	51.9	51.0	74.0	22.1	23.0
4.	4874.00	BB	42.2	40.2	34.0	34.6	5.4	0.7	47.7	45.7	74.0	26.3	28.3
5.	7311.00	BB	41.1	42.2	37.6	35.3	6.1	0.1	49.6	50.7	74.0	24.4	23.3
6.	9748.00	BB	44.6	45.2	38.8	35.9	7.8	0.6	55.9	56.5	74.0	18.1	17.5
7.	12185.00	BB	44.2	45.4	40.6	35.4	8.8	0.4	58.6	59.8	74.0	15.4	14.2

CALCULATION: READING + ANT. FACTOR + CABLE LOSS - AMP. GAIN + ATTEN.

■ ANTENNA: KHA-01 (SAS-200 571) 1-18GHz/KHA-06 (3116) 18-26GHz
 ■ CABLE: KCC-D16/D17 ■ AMP: APPRA05 (8449B) ■ SPECTRUMANALYZER: R3271A (KSA-04)

DATA OF RADIATION TEST

UL Japan, Inc.
YAMAKITA No.1 ANECHOIC CHAMBER
Report No. : 271E0337-YK-A

Applicant : RICOH COMPANY, LTD.
 Kind of Equipment : Option(s) for Radiocommunications
 Model No. : R-WL54MN
 Serial No. : 704S0191
 Power : AC120V/60Hz
 Mode : Receiving(2437MHz)
 Remarks : IEEE802.11b/g, AV (RBW:1MHz, VBW:10Hz)
 Date : 5/16/2007
 Test Distance : 3 m
 Temperature : 21 °C Engineer : Takahiro Suzuki
 Humidity : 47 %
 Regulation : FCC Part15B § 15.109(a)

No.	FREQ. [MHz]	ANT TYPE	READING		ANT FACTOR [dB/m]	AMP GAIN [dB]	CABLE LOSS [dB]	ATTEN. [dB]	RESULT		LIMITS [dB μ V/m]	MARGIN	
			HOR [dB μ V]	VER					HOR [dB μ V/m]	VER		HOR [dB]	VER
1.	1715.31	BB	36.4	36.6	27.5	35.7	3.1	10.1	41.4	41.6	54.0	12.6	12.4
2.	2249.36	BB	35.0	34.9	29.9	35.5	3.5	10.2	43.1	43.0	54.0	10.9	11.0
3.	2437.00	BB	33.6	33.5	29.7	35.5	3.4	10.4	41.6	41.5	54.0	12.4	12.5
4.	4874.00	BB	32.5	31.7	34.0	34.6	5.4	0.7	38.0	37.2	54.0	16.0	16.8
5.	7311.00	BB	31.2	33.3	37.6	35.3	6.1	0.1	39.7	41.8	54.0	14.3	12.2
6.	9748.00	BB	35.6	35.8	38.8	35.9	7.8	0.6	46.9	47.1	54.0	7.1	6.9
7.	12185.00	BB	34.7	35.2	40.6	35.4	8.8	0.4	49.1	49.6	54.0	4.9	4.4

CALCULATION: READING + ANT. FACTOR + CABLE LOSS - AMP. GAIN + ATTEN.

■ ANTENNA: KHA-01 (SAS-200 571) 1-18GHz/KHA-06 (3116) 18-26GHz
 ■ CABLE: KCC-D16/D17 ■ AMP: APPRA05 (8449B) ■ SPECTRUMANALYZER: R3271A (KSA-04)

Power Density (Conducted)

UL Japan, Inc.
YAMAKITA NO.2 Shielded Room

COMPANY : RICOH COMPANY, LTD
EQUIPMENT : Option(s) for Radiocommunications
MODEL NUMBER : R-WL54MN
SERIAL NUMBER : 704S0191
FCC ID : BBP-WLRWL541
POWER : AC120V/60Hz
TEST MODE : Transmitting

REPORT NO : 27IE0337-YK-A
REGULATION : Fcc Part15SubpartC 247(e)
DATE : 2007/05/22
TEMP./HUMI : 24°C/53%

ENGINEER : Tatsuya Arai

IEEE802.11b(11Mbps)

CH	FREQ [GHz]	S/A Reading [dBm]	Cable Loss [dB]	Results [dBm]	Limit [dBm]	MARGIN [dB]
Low	2.41276	-10.84	1.3	-9.54	8.0	17.5
Mid	2.43779	-11.26	1.3	-9.96	8.0	18.0
High	2.46118	-12.28	1.3	-10.98	8.0	19.0

IEEE802.11g(54Mbps)

CH	FREQ [GHz]	S/A Reading [dBm]	Cable Loss [dB]	Results [dBm]	Limit [dBm]	MARGIN [dB]
Low	2.41043	-14.12	1.3	-12.82	8.0	20.8
Mid	2.43671	-14.34	1.3	-13.04	8.0	21.0
High	2.46073	-15.41	1.3	-14.11	8.0	22.1

Sample Calculation:

$$\text{Result} = \text{Reading} + \text{Cable Loss}$$

Power Density: FCC 15.247(e)

COMPANY : RICOH COMPANY, LTD
EQUIPMENT : Option(s) for Radiocommunications
MODEL NUMBER: R-WL54MN
SERIAL NUMBER: 704S0191
FCC ID : BBP-WLRWL541
POWER : AC120V/60Hz
[IEEE802.11b(11Mbps)]

UL Japan. Yamakita No.2 Shielded Room
REPORT NO : 27IE0337-YK-A
REGULATION : FCC Part15SubpartC 247(e)
DATE : 2007/05/22
TEMP./HUMI : 24°C/53%
TEST MODE : Transmitting
ENGINEER : Tatsuya Arai

1. Ch 1: 2412MHz

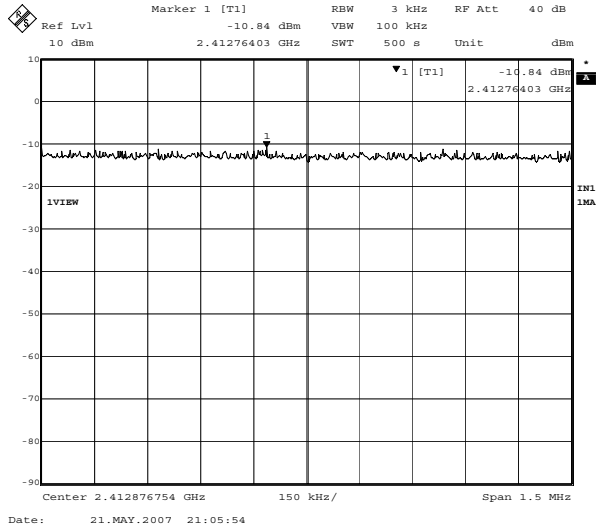

2. Ch 6: 2437MHz

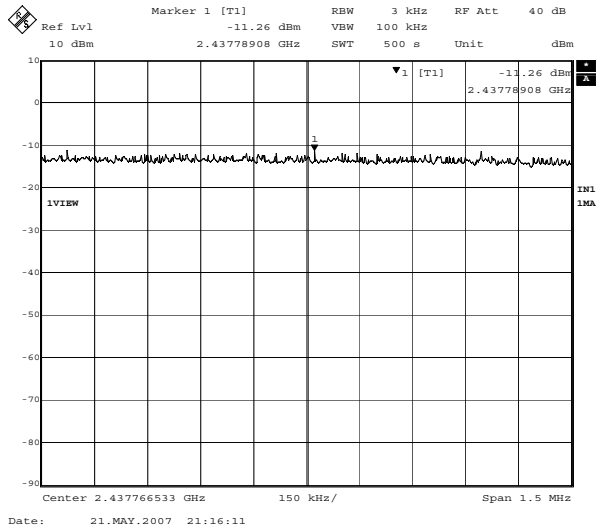

3. Ch 11: 2462MHz

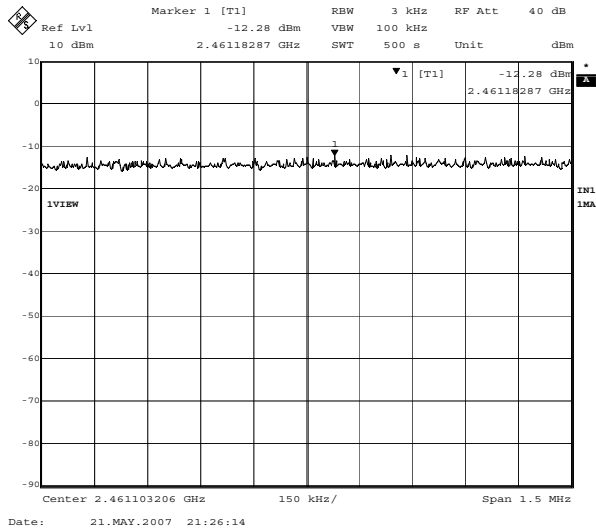

Power Density: FCC 15.247(e)

COMPANY : RICOH COMPANY, LTD
EQUIPMENT : Option(s) for Radiocommunications
MODEL NUMBER: R-WL54MN
SERIAL NUMBER: 704S0191
FCC ID : BBP-WLRWL541
POWER : AC120V/60Hz
[IEEE802.11g(54Mbps)]

UL Japan. Yamakita No.2 Shielded Room
REPORT NO : 27IE0337-YK-A
REGULATION : FCC Part15SubpartC 247(e)
DATE : 2007/05/22
TEMP./HUMI : 24°C/53%
TEST MODE : Transmitting
ENGINEER : Tatsuya Arai

1. Ch 1: 2412MHz

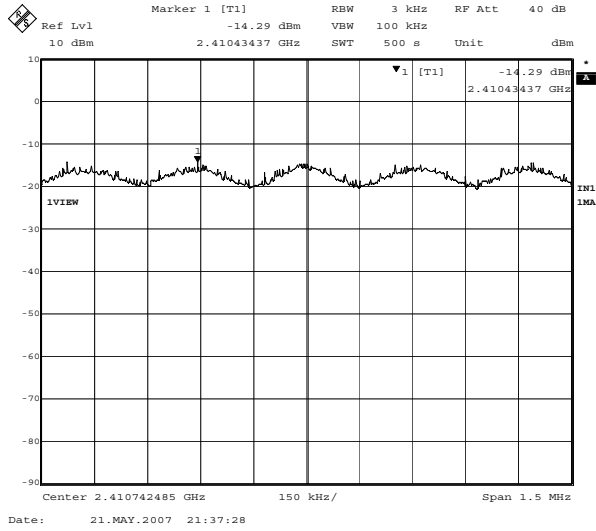

2. Ch 6: 2437MHz

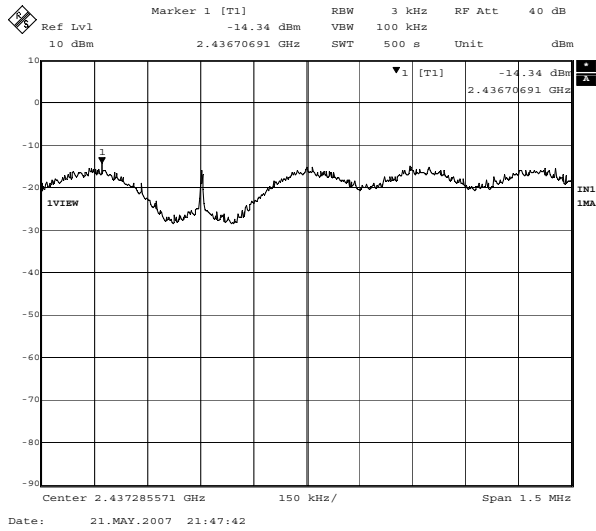

3. Ch 11: 2462MHz

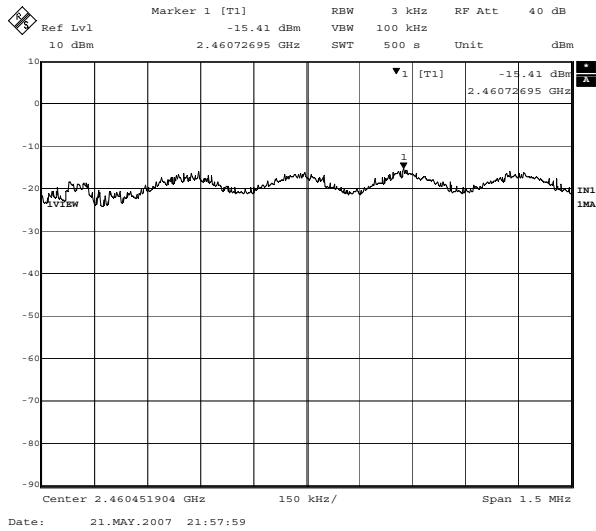

Occupied Bandwidth(99%)

COMPANY : RICOH COMPANY, LTD
EQUIPMENT : Option(s) for Radiocommunications
MODEL NUMBER : R-WL54MN
SERIAL NUMBER : 704S0191
FCC ID : BBP-WLRWL541
POWER : AC120V/60Hz
[IEEE802.11b(11Mbps)]

UL Japan, Inc. Yamakita No.2 Shielded Room
REPORT NO : 27IE0337-YK-A
REGULATION : RSS-210
DATE : 2007/05/22
TEMP./HUMI : 24°C/52%
TEST MODE : Transmitting
ENGINEER : Tatsuya Arai

1. Ch 1: 2412MHz/ Occupied Bandwidth:16.55MHz

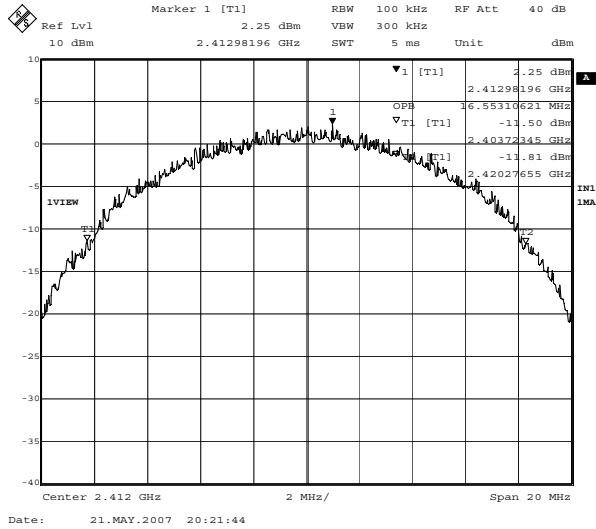

2. Ch 6: 2437MHz/ Occupied Bandwidth:16.55MHz

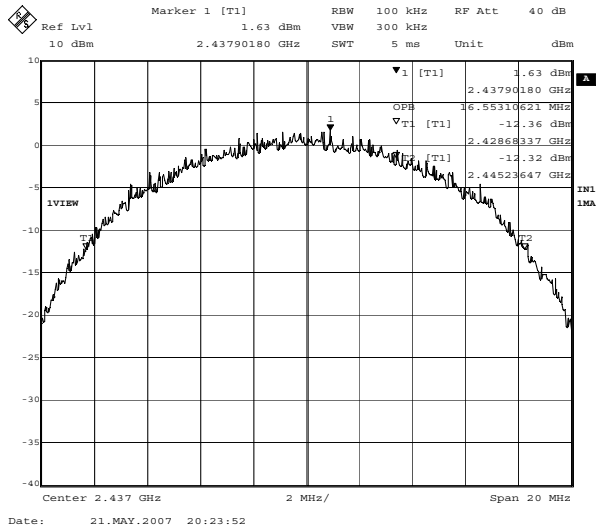

3. Ch 11: 2462MHz/ Occupied Bandwidth:16.51MHz

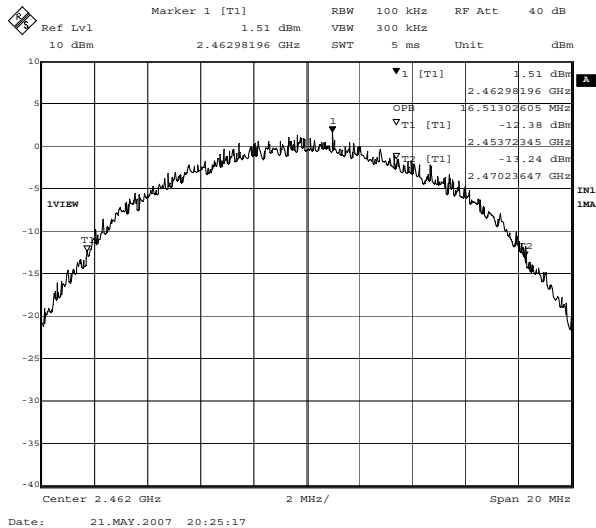

Occupied Bandwidth(99%)

COMPANY : RICOH COMPANY, LTD
EQUIPMENT : Option(s) for Radiocommunications
MODEL NUMBER : R-WL54MN
SERIAL NUMBER : 704S0191
FCC ID : BBP-WLRWL541
POWER : AC120V/60Hz
[IEEE802.11g(54Mbps)]

UL Japan, Inc. Yamakita No.2 Shielded Room
REPORT NO : 27IE0337-YK-A
REGULATION : RSS-210
DATE : 2007/05/22
TEMP./HUMI : 24°C/52%
TEST MODE : Transmitting
ENGINEER : Tatsuya Arai

1. Ch 1: 2412MHz/ Occupied Bandwidth:16.43MHz

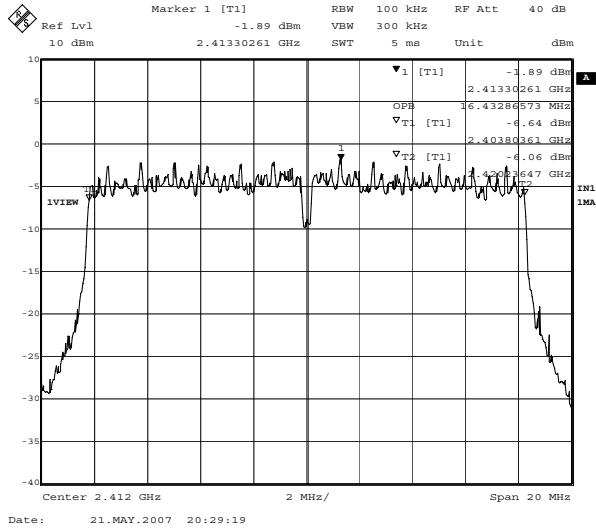

2. Ch 6: 2437MHz/ Occupied Bandwidth:16.43MHz

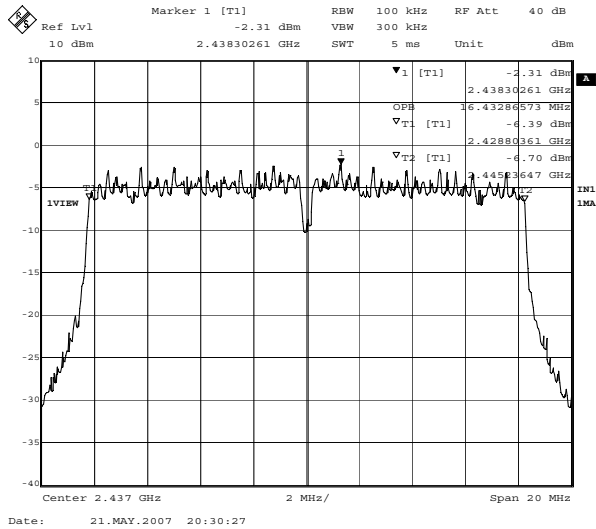

3. Ch 11: 2462MHz/ Occupied Bandwidth:16.43MHz

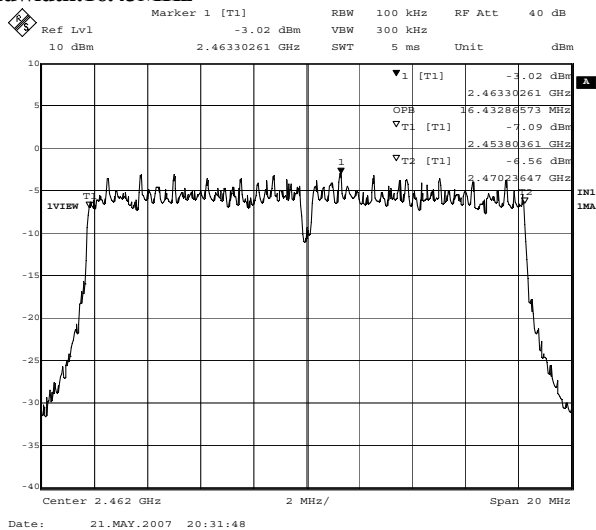

APPENDIX 3 Test Instruments

EMI test equipment

Control No.	Instrument	Manufacturer	Model No	Test Item	Calibration Date * Interval(month)
YA-CE	Conducted emission(software)	UL Japan	CE(Ver.1.6)	CE	-
YA-RE	Radiated emission(software)	UL Japan	RE(Ver.1.5)	RE	-
KAEC-01(NSA)	Anechoic Chamber	JSE	Semi 3m	RE	2006/08/31 * 12
KAF-05	Pre Amplifier	Agilent	8447D	RE	2007/04/13 * 12
KAT6-01	Attenuator	INMET	18N-6dB	RE	2007/03/28 * 12
KCC-30/31/32/34/KRM-03	Coaxial Cable/RF Relay Matrix	Fujikura/Suhner/TSJ	5D-2W/S04272B/RFM-E421	RE	2006/11/27 * 12
KCC-33/34/KRM-03	Coaxial Cable/RF Relay Matrix	Fujikura/Suhner/TSJ	5D-2W/S04272B/RFM-E421	CE	2006/11/27 * 12
KLA-03	Logperiodic Antenna	Schwarzbeck	USLP9143	RE	2007/01/06 * 12
KLS-02	LISN(AMN)	Schwarzbeck	NSLK8127	CE	2006/09/25 * 12
KSA-04	Spectrum Analyzer	Advantest	R3271A	CE/RE	2006/09/05 * 12
KOS-01	Humidity Indicator	Custom	CTH-190	CE/AT all	2006/07/14 * 24
KOS-02	Humidity Indicator	Custom	CTH-190	RE	2006/07/10 * 24
KAT10-S1	Attenuator	Agilent	8490D 010	RE	2007/04/11 * 12
KCC-D16/D17	Coaxial Cable	INSULATED WIRE INC	KPS-1501-200-KPS/KPS-1501-2000-KPS	RE	2007/02/05 * 12
KFL-01	Highpass Filter	Hewlett Packard	84300 80038	RE	2007/04/11 * 12
KHA-01	Horn Antenna	A.H.Systems	SAS-200/571	RE	2006/08/17 * 12
KHA-06	Horn Antenna	ETS LINDGREN	3116	RE	2006/08/17 * 12
APPRA05	Pre Amplifier	Hewlett Packard	8449B	RE	2006/12/21 * 12
MPM-09	Power Meter	Anritsu	ML2495A	AT 2	2006/09/20 * 12
MPSE-12	Power sensor	Anritsu	MA2411B	AT 2	2006/09/20 * 12
KTR-01	Test Receiver	Rohde & Schwarz	ESI40	CE/RE/AT 1,3,4	2007/04/12 * 12
KBA-03	Biconical Antenna	Schwarzbeck	BBA9106	RE	2007/01/06 * 12
KCC-D7	Coaxial Cable	Advantest	A01002	AT 1,3,4	2007/04/11 * 12

The expiration date of the calibration is the end of the expired month .

All equipment is calibrated with traceable calibrations . Each calibration is traceable to the national or international standards .

Test Item :

- CE: Conducted Emission
- RE: Out of Band Emission (Radiated)
- AT: Antenna terminal conducted test
 - 1: Bandwidth
 - 2: Maximum Peak Output Power
 - 3: Out of Band Emission (Conducted)
 - 4: Peak Power Density