



## EMI TEST REPORT

**Test Report No. : 27KE0096-HO-A-R2**

**Applicant** : RICOH COMPANY, LTD.  
**Type of Equipment** : Option(s) for Radiocommunications  
**Model No.** : R-WL54CN  
**Test standard** : FCC Part 15 Subpart E: 2007  
Section 15.407(DFS test only)  
**FCC ID** : BBP-WLRWL541  
**Test Result** : Complied

1. This test report shall not be reproduced in full or partial, without the written approval of UL Japan, Inc.
2. The results in this report apply only to the sample tested.
3. This sample tested is in compliance with above regulation.
4. The test results in this report are traceable to the national or international standards.
5. Original test report number of this report is 27KE0096-HO-A.

**Date of test** : June 21 to October 23, 2007

**Tested by** :   
Takahiro Hatakeda  
EMC Services

**Approved by** :   
Hironobu Shimoji  
Assistant manager of  
EMC Services



NVLAP LAB CODE: 200572-0

This laboratory is accredited by the NVLAP LAB CODE 200572-0, U.S.A. The tests reported herein have been performed in accordance with its terms of accreditation.  
\*As for the range of Accreditation in NVLAP, you may refer to the WEB address, <http://uljapan.co.jp/emc/nvlap.htm>

**UL Japan, Inc.**

**Head Office EMC Lab.**

4383-326 Asama-cho, Ise-shi, Mie-ken 516-0021 JAPAN

Telephone : +81 596 24 8116

Facsimile : +81 596 24 8124

<b>CONTENTS</b>	<b>PAGE</b>
<b>SECTION 1: Client information .....</b>	<b>3</b>
<b>SECTION 2: Equipment under test (E.U.T.).....</b>	<b>3</b>
<b>SECTION 3: Scope of Report.....</b>	<b>5</b>
<b>SECTION 4: Test specification, procedures &amp; results.....</b>	<b>5</b>
<b>SECTION 5: Operation of E.U.T. during testing .....</b>	<b>10</b>
<b>SECTION 6: In-Service Monitoring for Channel Move Time, Channel Closing Transmission Time .....</b>	<b>18</b>
<b>SECTION 7: In-Service Monitoring for Non-Occupancy Period .....</b>	<b>21</b>
<b>APPENDIX 1: Photographs of test setup .....</b>	<b>23</b>
<b>APPENDIX 2: Data of DFS test .....</b>	<b>24</b>
<b>Parameter Data for Radar Type 5.....</b>	<b>24</b>
<b>APPENDIX 3: Test instruments .....</b>	<b>25</b>

## **SECTION 1: Client information**

Company Name : RICOH COMPANY, LTD.  
Address : 810 Shimoimaizumi, Ebina-shi, Kanagawa-ken. 243-0460 Japan  
Telephone Number : +81-46-292-6870  
Facsimile Number : +81-46-231-9183  
Contact Person : Shinji Okada

## **SECTION 2: Equipment under test (E.U.T.)**

### **2.1 Identification of E.U.T.**

Type of Equipment : Option(s) for Radiocommunications  
Model No. : R-WL54CN  
Serial No. : 61290060 used for In-Service Monitoring for Non-Occupancy Period  
61290054 used for all other tests  
Rating : DC 3.3V  
Country of Manufacture : JAPAN  
Receipt Date of Sample : June 21, 2007  
Condition of EUT : Production prototype  
(Not for Sale: This sample is equivalent to mass-produced items.)  
Modification of EUT : No modification by the test lab.

### **2.2 Product Description**

Model: R-WL54CN (referred to as the EUT in this report) is Option(s) for Radiocommunications.

Equipment type : Transceiver  
Frequency of operation : [11b/g] 2412-2462MHz  
[11a] 5180-5320MHz  
Clock frequency : 11MHz, 20MHz  
Bandwidth & channel spacing : [11b/g] 22MHz & 5MHz  
[11a] 18MHz & 20MHz  
Type of modulation : IEEE802.11a: OFDM (BPSK, QPSK, 16QAM, 64QAM)  
IEEE802.11b: DSSS (DBPSK, DQPSK, CCK)  
IEEE802.11g: OFDM (BPSK, QPSK, 16QAM, 64QAM)  
Antenna type : Chip  
Antenna connector type : None  
Antenna gain : [11b/g] max +1dBi  
[11a] max +4dBi  
ITU code : D1D, G1D  
Operation temperature range : 0 ~ +65 deg.C.

---

## **UL Japan, Inc.**

### **Head Office EMC Lab.**

4383-326 Asama-cho, Ise-shi, Mie-ken 516-0021 JAPAN

Telephone : +81 596 24 8116

Facsimile : +81 596 24 8124

The EUT has a similar model, R-WL54MN.  
Differences between R-WL54CN and R-WL54MN are as follows.

Model Name	Antenna Type	Antenna gain
R-WL54CN	Chip	[11b/g] max +1dBi [11a] max +4dBi
R-WL54MN	Monopole	[11b/g] max +3dBi [11a] max +4dBi

DFS test was performed only with Model: R-WL54CN (Antenna: Chip) as representative by client request.

**FCC 15.31 (e)**

The RICOH product provides stable voltage (DC3.3V) constantly to the EUT (RF Module) regardless of input voltage. Therefore, the EUT complies with the requirement.

**FCC Part 15.203**

The antenna is not removable from the EUT. Therefore, the equipment complies with the antenna requirement of Section 15.203.

---

**UL Japan, Inc.**

**Head Office EMC Lab.**

4383-326 Asama-cho, Ise-shi, Mie-ken 516-0021 JAPAN

Telephone : +81 596 24 8116

Facsimile : +81 596 24 8124

### **SECTION 3: Scope of Report**

The EUT has the channels from 5180 to 5320MHz.

This report only covers DFS requirement subject to 5250-5350MHz bands, as specified by the following referenced procedures.

### **SECTION 4: Test specification, procedures & results**

#### **4.1 Test Specification**

Test Specification : FCC Part15 Subpart E : 2006  
Title : FCC 47CFR Part15 Radio Frequency Device  
Subpart E Unlicensed National Information Infrastructure Devices  
Section 15.407 General technical requirements

Test Specification : FCC 06-96 APPENDIX  
Title : COMPLIANCE MEASUREMENT PROCEDURES FOR UNLICENSED-  
NATIONAL INFORMATION INFRASTRUCTURE DEVICES  
OPERATING IN THE 5250-5350 MHz AND 5470-5725MHz BANDS  
INCORPORATING DYNAMIC FREQUENCY SELECTION

---

**UL Japan, Inc.**

**Head Office EMC Lab.**

4383-326 Asama-cho, Ise-shi, Mie-ken 516-0021 JAPAN

Telephone : +81 596 24 8116

Facsimile : +81 596 24 8124

4.2 Procedures and results

Table 1: Applicability of DFS Requirements

Requirement	Operating Mode	Test Procedures & Limits	Deviation	Results
	Client without Radar Detection			
U-NII Detection Bandwidth	Not required	FCC 06-96 Appendix 7.8.1	N/A	N/A
Initial Channel Availability Check Time	Not required	FCC15.407 (h) ----- FCC 06-96 Appendix 7.8.2.1	N/A	N/A
Radar Burst at the Beginning of the Channel Availability Check Time	Not required	FCC15.407 (h) ----- FCC 06-96 Appendix 7.8.2.2	N/A	N/A
Radar Burst at the End of the Channel Availability Check Time	Not required	FCC15.407 (h) ----- FCC 06-96 Appendix 7.8.2.3	N/A	N/A
In-Service Monitoring for Channel Move Time, Channel Closing Transmission Time	Yes	FCC15.407 (h) ----- FCC 06-96 Appendix 7.8.3	N/A	Complied
In-Service Monitoring for Non-Occupancy period	Yes *	FCC15.407 (h) ----- FCC 06-96 Appendix 7.8.3	N/A	Complied
Statistical Performance Check	Not required	FCC15.407 (h) ----- FCC 06-96 Appendix 7.8.4	N/A	N/A

\*Although this test was not required in FCC 06-96, it was performed as additional test.

Table 2: DFS Detection Thresholds for Master Devices and Client Devices With Radar

Maximum Transmit Power	Value (See Notes 1 and 2)
≥ 200 milliwatt	-64 dBm
< 200 milliwatt	-62 dBm
Note 1: This is the level at the input of the receiver assuming a 0 dBi receive antenna. Note 2: Throughout these test procedures an additional 1 dB has been added to the amplitude of the test transmission waveforms to account for variations in measurement equipment. This will ensure that the test signal is at or above the detection threshold level to trigger a DFS response.	

**Table 3 DFS Response Requirement Values**

Parameter	Value
Non-occupancy period	Minimum 30 minutes
Channel Availability Check Time	60 seconds
Channel Move Time	10 seconds See Note 1
Channel Closing Transmission Time	200 milliseconds + an aggregate of 60 milliseconds over remaining 10 second period. See Notes 1 and 2
U-NII Detection Bandwidth	Minimum 80% of the U-NII 99% transmission power bandwidth See Note 3
<p><b>Note 1:</b> The instant that the Channel Move Time and the Channel Closing Transmission Time begins is as follows:</p> <ul style="list-style-type: none"><li>• For the Short Pulse Radar Test Signals this instant is the end of the <i>Burst</i>.</li><li>• For the Frequency Hopping radar Test Signal, this instant is the end of the last radar <i>Burst</i> generated</li><li>• For the Long Pulse Radar Test Signal this instant is the end of the 12 second period defining the <i>Radar Waveform</i>.</li></ul> <p><b>Note 2:</b> The Channel Closing Transmission Time is comprised of 200 milliseconds starting at the beginning of the Channel Move Time plus any additional intermittent control signals required to facilitate a Channel move (an aggregate of 60 milliseconds) during the remainder of the 10 second period. The aggregate duration of control signal will not count quiet periods in between transmissions.</p> <p><b>Note 3:</b> During the U-NII Detection Bandwidth detection test, radar type 1 is used and for each frequency step the minimum percentage of detection is 90 percent. Measurements are performed with no data traffic.</p>	

**Table 4 Short Pulse Radar Test Waveform**

Radar Type	Pulse Width (μsec)	PRI (μsec)	Number of Pulses	Minimum Percentage of Successful Detection	Minimum Number of Trials
1	1	1428	18	60%	30
2	1-5	150-230	23-29	60%	30
3	6-10	200-500	16-18	60%	30
4	11-20	200-500	12-16	60%	30
Aggregate (Rader Types 1-4)				80%	120

**Table 5 Long Pulse Radar Test Waveform**

Radar Type	Pulse Width (μsec)	Chip Width (MHz)	PRI (μsec)	Number of Pulses per Burst	Number of Burst	Minimum Percentage of Successful Detection	Minimum Number of Trials
5	50-100	5-20	1000-2000	1-3	8-20	80%	30

**Table 6 Frequency Hopping Radar Test Waveform**

Radar Type	Pulse Width (μsec)	PRI (μsec)	Pulse per Hop (kHz)	Hopping Rate (kHz)	Hopping Sequence Length (msec)	Minimum Percentage of Successful Detection	Minimum Number of Trials
6	1	333	9	0.333	300	70%	30



### 4.3 Test Location

UL Japan, Inc. Head Office EMC Lab. \*NVLAP Lab. code: 200572-0  
 4383-326 Asama-cho, Ise-shi, Mie-ken 516-0021 JAPAN  
 Telephone: +81 596 24 8116 Facsimile: +81 596 24 8124

	FCC Registration Number	IC Registration Number	Width x Depth x Height (m)	Size of reference ground plane (m) / horizontal conducting plane	Other rooms
No.1 semi-anechoic chamber	313583	IC4247	19.2 x 11.2 x 7.7m	7.0 x 6.0m	No.1 Power source room
No.2 semi-anechoic chamber	655103	IC4247-2	7.5 x 5.8 x 5.2m	4.0 x 4.0m	-
No.3 semi-anechoic chamber	148738	IC4247-3	12.0 x 8.5 x 5.9m	6.8 x 5.75m	No.3 Preparation room
No.3 shielded room	-	-	4.0 x 6.0 x 2.7m	N/A	-
No.4 semi-anechoic chamber	134570	IC4247-4	12.0 x 8.5 x 5.9m	6.8 x 5.75m	No.4 Preparation room
No.4 shielded room	-	-	4.0 x 6.0 x 2.7m	N/A	-
No.5 semi-anechoic chamber	-	-	6.0 x 6.0 x 3.9m	6.0 x 6.0m	-
No.6 shielded room	-	-	4.0 x 4.5 x 2.7m	4.75 x 5.4 m	-
No.6 measurement room	-	-	4.75 x 5.4 x 3.0m	4.75 x 4.15 m	-
No.7 shielded room	-	-	4.7 x 7.5 x 2.7m	4.7 x 7.5m	-
No.8 measurement room	-	-	3.1 x 5.0 x 2.7m	N/A	-

\* Size of vertical conducting plane (for Conducted Emission test) : 2.0 x 2.0m for No.1, No.2, No.3, and No.4 semi-anechoic chambers and No.3 and No.4 shielded rooms.

### 4.4 Test set up and Test instruments of DFS

Refer to APPENDIX 1 to 3.

**SECTION 5: Operation of E.U.T. during testing**

**5.1 Operating Modes**

The EUT, which is a Client Device without Radar detection capability, operates over the 5260-5320MHz ranges.

The highest power level is 12.46dBm EIRP in the 5250-5350MHz band.  
The lowest power level is 10.87dBm EIRP in the 5250-5350MHz band.

Power level(EIRP) of the EUT[dBm]

Antenna Type	Antenna Gain [dBi]	5250-5350MHz Band	
		Output Power (Min)	Output Power(Max)
chip antenna *1)	4.00	10.87	12.46
monopole antenna *2)	4.00	10.87	12.46

\*1). Refer to 27IE0337-YK-F, FCC Part 15E (FCC 15.407) report for other parts than DFS  
\*2). Refer to 27IE0337-YK-B, FCC Part 15E (FCC 15.407) report for other parts than DFS

The lowest antenna assembly gain of all available antenna assemblies is 4.00dBi.

The EUT uses one transmitter connected to two 50-ohm coaxial antenna ports via a diversity switch. Both antenna ports are connected to the test system via a power divider to perform conducted tests.

WLAN traffic is generated by streaming the MPEG Test file “6 ½ Magic Hours” from the Master to the Client in full motion video mode using the media player with the V2.61 Codec package.

The EUT utilizes the 802.11a architecture, with a nominal channel bandwidth of 18MHz.

The FCC ID for the Master Device used with EUT for DFS testing is LDK102056.

The rated output power of the Master unit is >200mW(23dBm). Therefore the required interference threshold level is -64 dBm. After correction for antenna gain and procedural adjustments, the required conducted threshold at the antenna port is -64 + 1 + 3.5=-59.5 dBm (threshold level + additional 1dB + antenna gain).

The calibrated conducted DFS detection Threshold level is set to -64dBm. The tested level is lower than the required level hence it provides margin to the limit.

The FlashROM, which stores DFS’s firmware, adopts BGA package so that users are not able to access to the end terminal.

The channel information is programmed in I2CROM. The data format is RICOH’s original and it is not open to the public. The end terminal of I2CROM is fixed with resin to protect against user’s access.

As above, users cannot access the DFS setup and the EUT cannot transmit at the unusable frequencies in US.

## 5.2 Configuration and peripherals

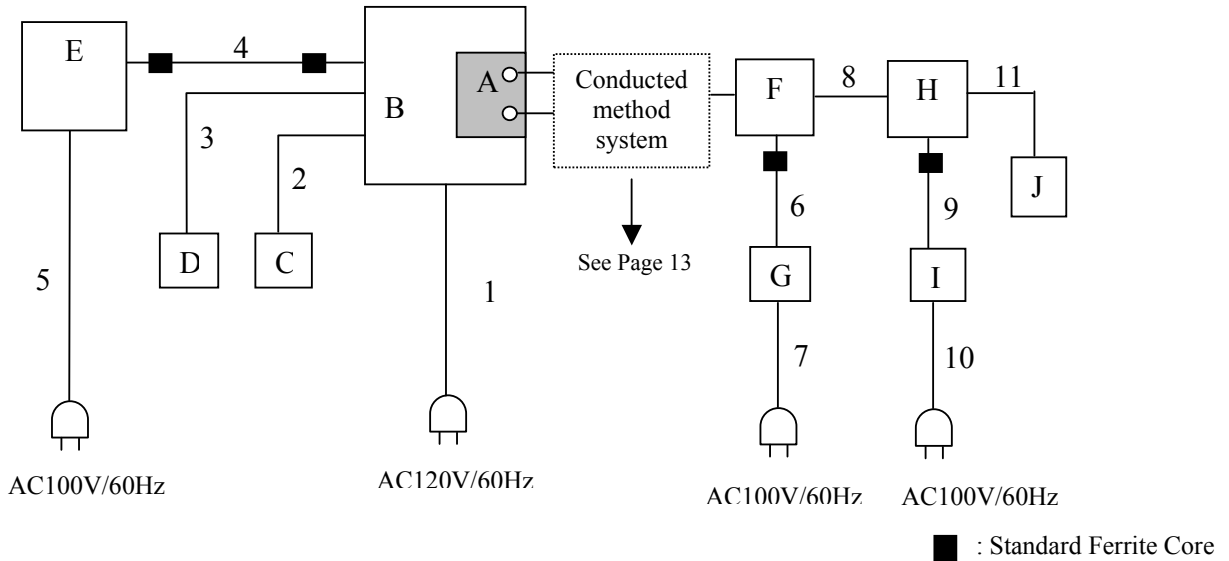

### Description of EUT and Support equipment

No.	Item	Model number	Serial number	Manufacturer	Remarks
A	Option(s) for Radiocommunications	R-WL54CN	61290060 *1) 61290054 *2)	RICOH	EUT
B	PC	-	-	RICOH	-
C	Mouse	MA-5UPOB	201001071	SANWA SUPPLY	-
D	Keyboard	5121W	E92601023	BEHAVIOR TECH COMPUTER CORP.	-
E	Monitor	LCD-AD 195VW - HS	U8W00044423T	I O DATA	-
F	Wireless LAN access point (Master Device)	AIR-AP1242AG- A-K9	FTX1045B9L0	Cisco Systems	FCC ID : LDK102056
G	AC Adapter	ADP-18PB	PZT0639562214	Cisco Systems	-
H	Note PC	CF-R3	SPKSA55729	Panasonic	-
I	AC Adapter	CF-AA1625A	1625AM305220122C	Panasonic	-
J	Mouse	M-N3URSV	50407986A	ELECOM	-

\*1) Used for In-Service Monitoring for Non-Occupancy Period

\*2) Used for all other tests

**UL Japan, Inc.**

**Head Office EMC Lab.**

4383-326 Asama-cho, Ise-shi, Mie-ken 516-0021 JAPAN

Telephone : +81 596 24 8116

Facsimile : +81 596 24 8124

**List of cables used**

No.	Name	Length (m)	Shield	
			Cable	Connector
1	AC Cable	1.5	Unshielded	Unshielded
2	USB Cable	1.0	Shielded	Shielded
3	Serial Cable	1.6	Unshielded	Unshielded
4	Serial Cable	1.0	Unshielded	Unshielded
5	AC Cable	1.5	Unshielded	Unshielded
6	DC Cable	1.8	Unshielded	Unshielded
7	AC Cable	2.0	Unshielded	Unshielded
8	LAN Cable	1.0	Unshielded	Unshielded
9	DC Cable	1.2	Unshielded	Unshielded
10	AC Cable	0.9	Unshielded	Unshielded
11	USB Cable	1.0	Shielded	Shielded

### 5.3 Test and Measurement System

#### SYSTEM OVERVIEW

The measurement system is based on a conducted test method.

The software selects waveform parameters from within the bounds of the signal type on a random basis using uniform distribution. The short pulse types 2, 3, and 4, the long pulse type 5, and the frequency hopping type 6 parameters are randomized at run-time.

The signal monitoring equipment consists of a spectrum analyzer with the capacity to display 8192 bins on the horizontal axis. A time-domain resolution of 2 msec/bin is achievable with a 16 second sweep time, meeting the 10 seconds short pulse reporting criteria. The aggregate ON time is calculated by multiplying the number of bins above a threshold during a particular observation period by the dwell time per bin, with the analyzer set to peak detection. A time-domain resolution of 3 msec/bin is achievable with a 24 second sweep time, meeting the 22 second long pulse reporting criteria and allowing a minimum of 10 seconds after the end of the long pulse waveform.

#### FREQUENCY HOPPING RADAR WAVEFORM GENERATING SUBSYSTEM

The first 100 frequencies are selected out of the hopping sequence of the randomized 475 hop frequencies.

Only a *Burst* that has the frequency falling within the receiver bandwidth of the tested U-NII device is selected among those frequencies. (Frequency-domain simulation). The radar waveform generated at the start time of the selected *Burst* (Time-domain simulation) is download to the Signal Generator.

If all of the randomly selected 100 frequencies do not fall within the receiver bandwidth of the U-NII device, the radar waveform is not used for the test.

---

**UL Japan, Inc.**

**Head Office EMC Lab.**

4383-326 Asama-cho, Ise-shi, Mie-ken 516-0021 JAPAN

Telephone : +81 596 24 8116

Facsimile : +81 596 24 8124

**CONDUCTED METHODS SYSTEM BLOCK DIAGRAM**

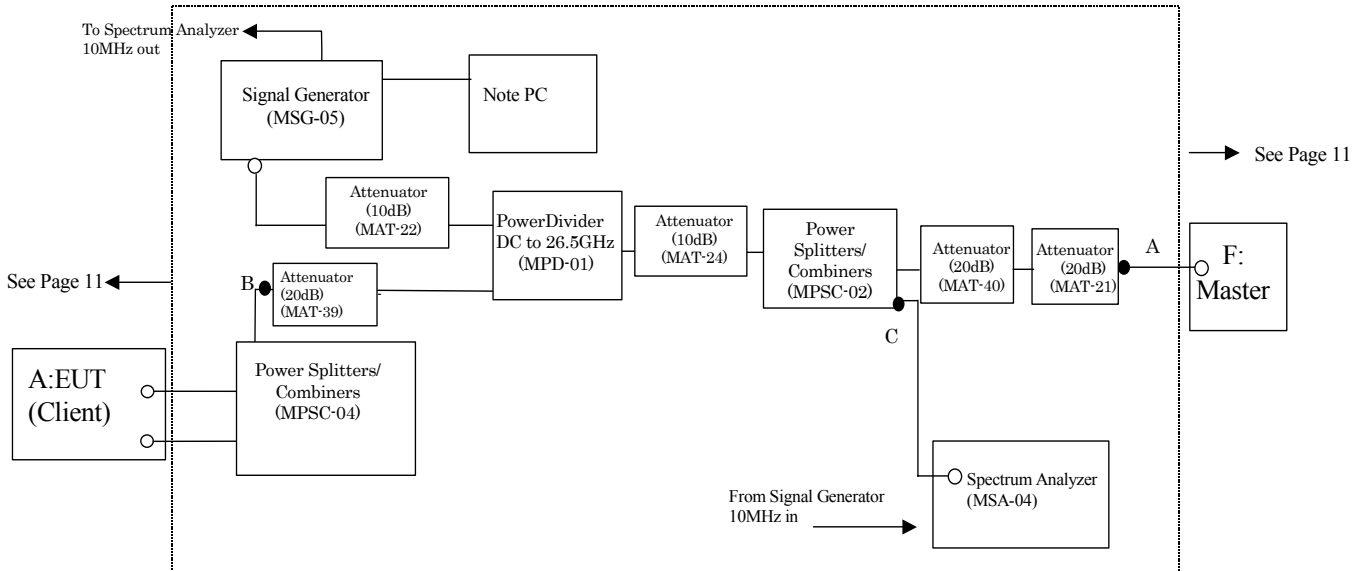

**MEASUREMENT SYSTEM FREQUENCY REFERENCE**

Lock the signal generator and the spectrum analyzer to the same reference sources as follows: Connect the 10MHz OUT on the signal generator to the 10MHz IN on the spectrum analyzer and set the spectrum analyzer 10MHz In to On.

**SYSTEM CALIBRATION**

**Step 1:** Set the system as shown in Figure 3 of FCC 06-96 7.2.1.

**Step 2:** Adjust each attenuator to fulfill the following three conditions:

- WLAN can be communicated, and
- Rader detection threshold level is bigger than Client Device traffic level on the spectrum analyzer, and
- Master Device traffic level is not displayed on the spectrum analyzer.

**Step 3:** Terminate 50 ohm at B and C points, and connect the spectrum analyzer to the point A. (See the figure on page 13) At the point A, adjust the signal generator and spectrum analyzer to the center frequency of the channel to be measured. Download the applicable radar waveforms to the signal generator. Select the radar waveform, trigger a burst manually and measure the amplitude on the spectrum analyzer. Readjust the amplitude of the signal generator as required so that the peak level of the waveform is at a displayed level equal to the required or desired interference detection threshold. Separate signal generator amplitude settings are determined as required for each radar type.

**Step 4:** Without changing any of the instrument settings, restore the system setting to Step 2 and adjust the Reference Level Offset of the spectrum analyzer to the level at Step 3.

By taking the above steps 1 to 4, the spectrum analyzer displays the level of the signal generator as received at the antenna ports of the Master Device.

See Clause 5.4 for Plots of Noise, Rader Waveforms, and WLAN signals.

**5.4 Plots of Noise, Rader Waveforms, and WLAN signals**

Plots of System Noise Floor

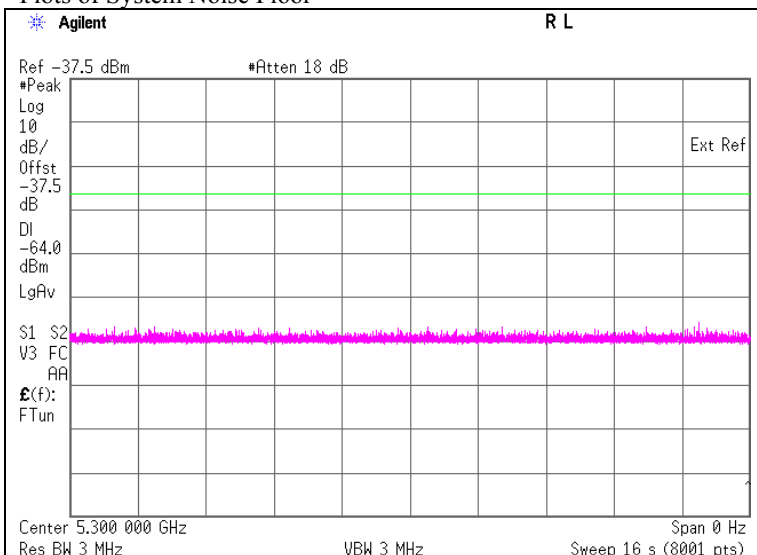

It was confirmed that the EUT did not transmit before having received appropriate control signals from a Master Device.

Plots of Radar Waveforms

Rader Type 1

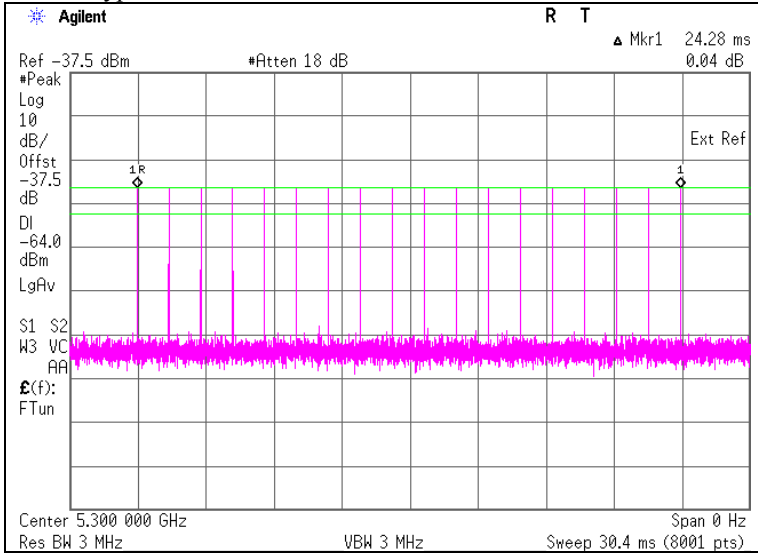

Rader Type 5

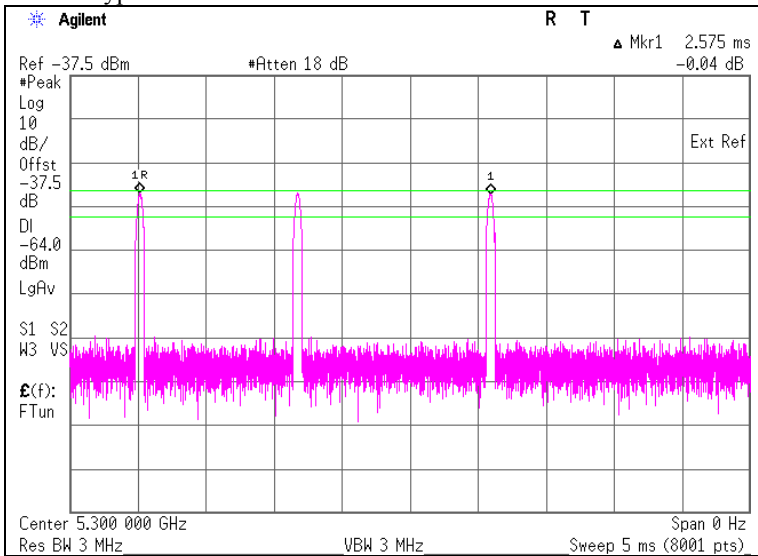



Plots of WLAN Traffic

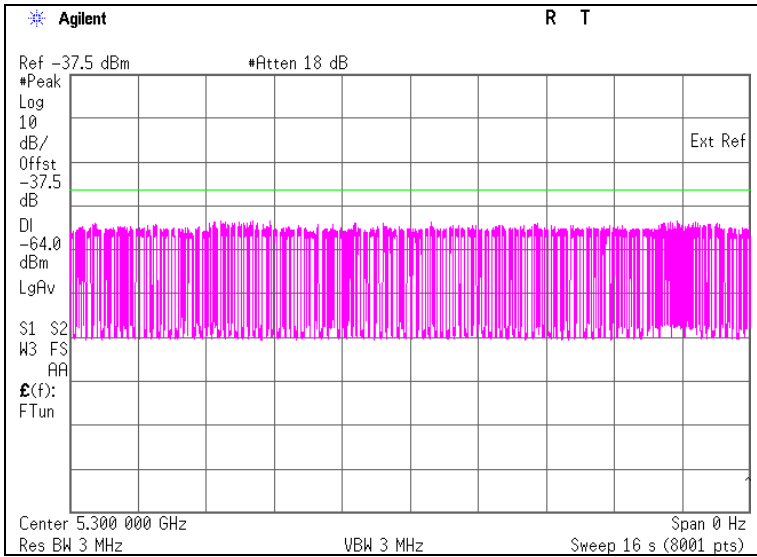

## **SECTION 6: In-Service Monitoring for Channel Move Time, Channel Closing Transmission Time**

### **6.1 Operating environment**

Test place : No.7 shielded room  
Temperature : 24deg.C.  
Humidity : 54%

### **6.2 Test Procedure**

Stream the MPEG test file from the Master Device to the Client Device on the test Channel for the entire period of the test. The Radar Waveform generator sends a Burst of pulses for one of the Short Pulse Radar Types 1-4 at levels defined , on the Operating Channel. An additional 1 dB is added to the radar test signal to ensure it is at or above the DFS Detection Threshold, accounting for equipment variations/errors.

Observe the transmissions of the EUT at the end of the radar Burst on the Operating Channel for duration greater than 10 seconds.

### **6.3 Test data**

Test Item	Unit	Measurement Time	Limit	Results
Channel Move Time *1)	[sec]	0.160	10.000	Pass
Channel Closing Transmission Time *2)	[msec]	0	60	Pass

\*1) Channel Move Time is calculated as follows:

$$(\text{Channel Move Time}) = (\text{End of Transmission}) - (\text{End of Burst}) = 1.236 - 1.076$$

\*2). Channel Closing Transmission Time is calculated from (End of Burst + 200msec) to (End of Burst + 10sec )

$$(\text{Channel Closing Transmission Time}) = (\text{Number of analyzer bins showing transmission}) * (\text{dwell time per bin}) \\ = 0 * 2(\text{msec})$$

---

**UL Japan, Inc.**

**Head Office EMC Lab.**

4383-326 Asama-cho, Ise-shi, Mie-ken 516-0021 JAPAN

Telephone : +81 596 24 8116

Facsimile : +81 596 24 8124

Radar Type 1

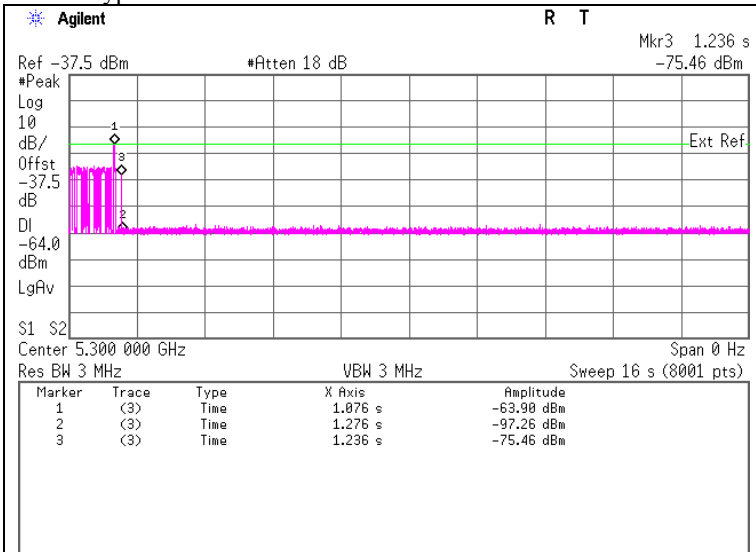

**Marker 1 : End of Burst** : 1076 ms  
**Marker 2 : End of Burst + 200 msec** : 1276 ms  
**Marker 3 : End of Transmission** : 1236 ms

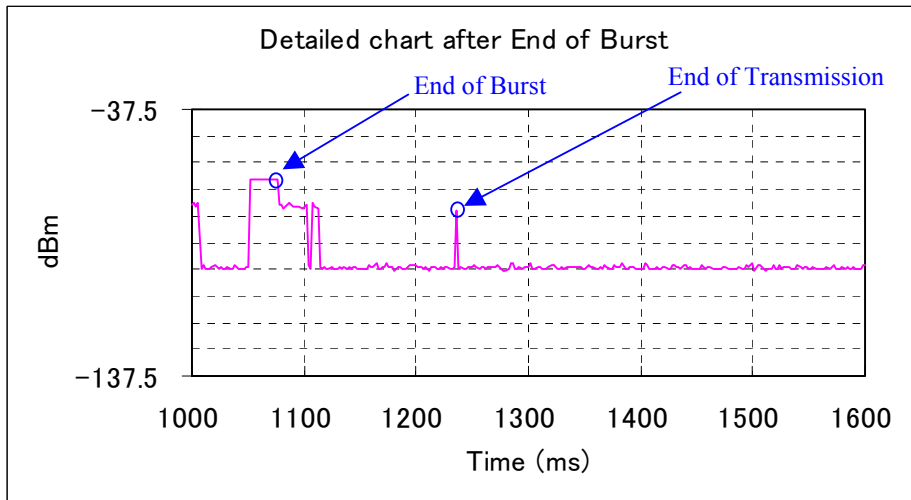

Radar Type 5

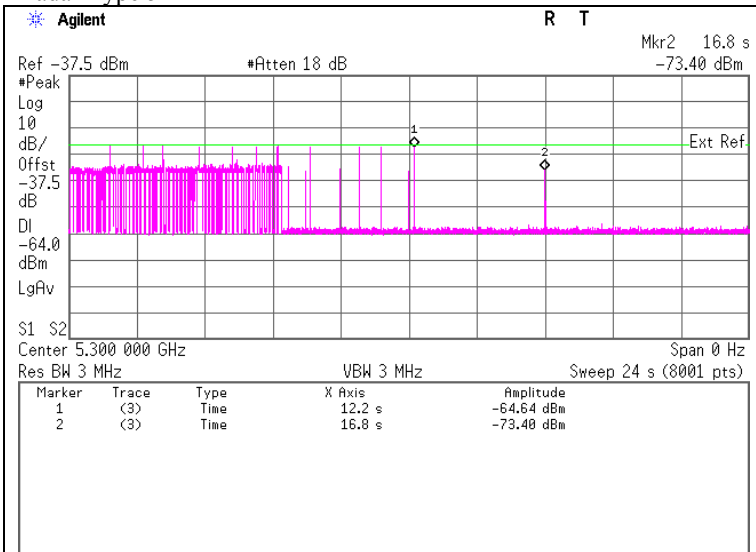

**Marker 1 : End of Burst : 12200 ms**  
**Marker 2 : End of Transmission : 16800 ms**

6.4 Test result

Test result: Pass

Date : 06 / 21 / 2007

Test engineer : Takahiro Hatakeda

UL Japan, Inc.

Head Office EMC Lab.

4383-326 Asama-cho, Ise-shi, Mie-ken 516-0021 JAPAN

Telephone : +81 596 24 8116

Facsimile : +81 596 24 8124

**SECTION 7: In-Service Monitoring for Non-Occupancy Period**

**7.1 Operating environment**

Test data	: September 5, 2007	October 23, 2007
Test place	: No.6 measurement room	No.6 measurement room
Temperature	: 26deg.C.	25deg.C.
Humidity	: 59%	43%

**7.2 Test Procedure**

The following two tests are performed:

- 1).Stream the MPEG test file from the Master Device to the Client Device on the test Channel for the entire period of the test.  
 The Radar Waveform generator sends a Burst of pulses for one of the Radar Types 1-6 at levels defined on the Operating Channel. An additional 1 dB is added to the radar test signal to ensure it is at or above the DFS Detection Threshold, accounting for equipment variations/errors.  
 Observe the transmissions of the EUT after the Channel Move Time on the Operating Channel for duration greater than 30 minutes.
  
- 2). Stream the MPEG test file from the Master Device to the Client Device on the test Channel for the entire period of the test.  
 Observe the transmissions of the EUT on the Operating Channel for duration greater than 30 minutes after the Master Device is shut off.

**7.3 Test data**

1).Radar Type 1

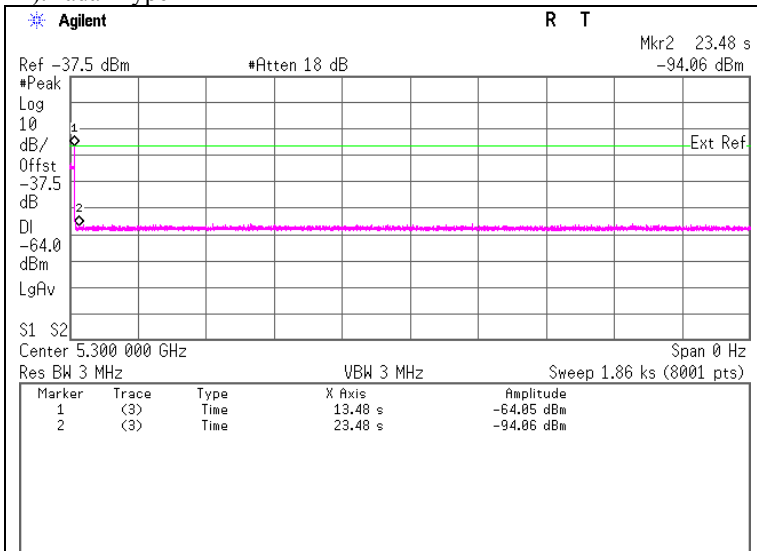

**Marker 1 : End of Burst : 13480 ms**  
**Marker 2 : End of Burst +10sec : 23480 ms**

2). Master is shut off

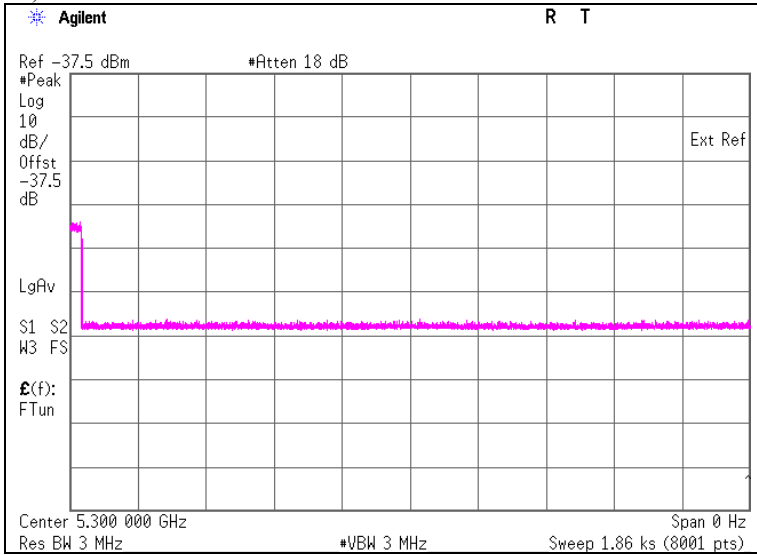

7.4 Test result

Test result: Pass

Date : 09 / 05 / 2007, 10 / 23 / 2007

Test engineer : Takahiro Hatakeda