



RADIO TEST REPORT

Test Report No. : 27IE0337-YK-D

Applicant : RICOH COMPANY, LTD.
Type of Equipment : Option(s) for Radiocommunications
Model No. : R-WL54CG
FCC ID : BBP-WLRW54G1
Test Standard : FCC Part15 Subpart C: 2007
: FCC Part15 Subpart B: 2007
Test Result : Complied

1. This test report shall not be reproduced except in full or partial, without the written approval of UL Japan, Inc.
2. The results in this report apply only to the sample tested.
3. This sample tested is in compliance with the limits of the above regulation.
4. The test results in this test report are traceable to the national or international standards.

Date of test: May 9, 10, 11, 22, 28 and 29, 2007

Tested by: T. Imamura & I. Isozaki
Toyokazu Imamura & Ichiro Isozaki

T. Arai
Tatsuya Arai

Approved by: O. Watatani
Osamu Watatani
Manager of Yamakita EMC Lab.

Table of Contents	Page
1 Applicant Information	3
2 Equipment under test (E.U.T.)	3
3 Test Specification, Procedures and Results	4
4 System Test Configuration	6
5 Conducted emission	7
6 6dB Bandwidth & Occupied Bandwidth (99%)	7
7 Maximum Peak Output Power	7
8 Out of Band Emissions (Antenna Port Conducted)	7
9 Out of Band Emissions (Radiated)	8
10 Peak Power Density	9
<u>Contents of Appendixes</u>	10
APPENDIX 1: Photographs of test setup	11
APPENDIX 2: Test Data	14
APPENDIX 3: Test instruments	68

1 Applicant Information

Company Name : RICOH COMPANY, LTD.
Address : 810 Shimoimaizumi, Ebina-shi, Kanagawa-ken, 243-0460 Japan
Telephone Number : +81-46-292-6870
Facsimile Number : +81-46-231-9183
Contact Person : Shinji Okada

2 Equipment under test (E.U.T.)

2.1 Identification of E.U.T.

Type of Equipment : Option(s) for Radiocommunications
Model No. : R-WL54CG
Serial No. : 61290054
Rating : DC3.3V
Country of Manufacture : Japan
Receipt Date of Sample : May 9, 2007
Condition of EUT : Production prototype
(Not for Sale: This sample is equivalent to mass-produced items.)

2.2 Product Description

Model: R-WL54CG (referred to as the EUT in this report) is Option(s) for Radiocommunications.

Equipment type : Transceiver
Frequency of operation : 2412-2462MHz
Clock frequency : 11MHz, 20MHz
Bandwidth & channel spacing : 22MHz & 5MHz
Type of modulation : IEEE802.11b: DSSS (DBPSK, DQPSK, CCK)
IEEE802.11g: OFDM (BPSK, QPSK, 16QAM, 64QAM)
Antenna type : Chip
Antenna connector type : None
Antenna gain : max +3dBi
ITU code : D1D, G1D
Operation temperature range : 0 ~ +65 deg.C.

FCC 15.31 (e)

The RICOH product provides stable voltage (DC3.3V) constantly to the EUT (RF Module) regardless of input voltage. Therefore, the EUT complies with the requirement.

FCC Part 15.203

The antenna is not removable from the EUT. Therefore, the equipment complies with the antenna requirement of Section 15.203.

UL Japan, Inc.

YAMAKITA EMC LAB.

907 Kawanishi, Yamakita-machi, Ashigarakami-gun, Kanagawa-ken, 258-0124 JAPAN

Telephone: +81 465 77 1011 Facsimile: +81 465 77 2112

MF060b (18.06.07)

3 Test Specification, Procedures and Results

3.1 Test specification

Test Specification : FCC Part 15 Subpart B: 2007
 Title : FCC 47CFR Part 15 Radio Frequency Device
 Subpart B Unintentional Radiators
 Test specification : FCC Part15 Subpart C: 2007
 Title : FCC 47CFR Part15 Radio Frequency Device Subpart C Intentional Radiators
 Section 15.207 Conducted limits
 Section 15.209 Radiated emission limits, general requirements
 Section 15.247 Operation within the bands 902-928MHz, 2400-2483.5MHz,
 and 5725-5850MHz

3.2 Procedures & Results

Item	Test Procedure	Specification	Remarks	Deviation	Worst Margin	Results
Conducted Emission	ANSI C63.4:2003 7. AC powerline conducted emission measurements	FCC 15.107(a) & 207	-	N/A	17.8dB (23.6294MHz, AV, Tx 2412MHz, IEEE802.11b (11Mbps))	Complied
6dB Bandwidth	ANSI C63.4:2003 13. Measurement of intentional radiators	FCC 15.247 (a)(2) & 15.209	Conducted	N/A	-	Complied
Maximum Peak Output Power	ANSI C63.4:2003 13. Measurement of intentional radiators	FCC 15.247 (b)(3) & 15.209	Conducted	N/A	-	Complied
Out of Band Emission & Restricted Band Edges	ANSI C63.4:2003 13. Measurement of intentional radiators	FCC 15.109, 15.247 (d) & 15.209	Conducted / Radiated	N/A	Tx: 3.1dB (320.00MHz, Horizontal, IEEE802.11g (54Mbps) Tx 2437MHz & 2462MHz) Rx: 3.3dB (320.00MHz, Horizontal, Rx 2437MHz)	Complied
Power Density	ANSI C63.4:2003 13. Measurement of intentional radiators	FCC 15.247 (e) & 15.209	Conducted	N/A	-	Complied
Antenna power conduction for receivers	ANSI C63.4: 2003 12.1.5 Antenna-conducted power measurements	FCC 15.111 (a)	-	N/A *1)	-	N/A

*1) The test is not applicable since the EUT does not tune in the frequency range 30 to 960MHz.

Note: UL Japan's EMI Work Procedures No.QPM05.

These tests were also referred to "Guidance on Measurement for Digital Transmission Systems Section15.247".

* Other than mentioned in 3.3, no addition, exclusion nor deviation has been made from the standard.

3.3 Addition to standard

Item	Test Procedure	Specification	Remarks	Worst Margin	Results
Occupied Bandwidth (99%)	ANSI C63.4:2003 13. Measurement of intentional radiators RSS-Gen 4.4.1	RSS-Gen 4.4.1	Conducted	-	Complied

UL Japan, Inc.

YAMAKITA EMC LAB.

907 Kawanishi, Yamakita-machi, Ashigarakami-gun, Kanagawa-ken, 258-0124 JAPAN

Telephone: +81 465 77 1011

Facsimile: +81 465 77 2112

MF060b (18.06.07)

3.4 Uncertainty

The measurement uncertainty (with a 95% confidence level) is as follows:

	No.1 open site	No.2 open site	No.1 anechoic chamber
Conducted emission			
150kHz-30MHz	2.8 dB	2.8 dB	2.8 dB
Radiated emission (3m)			
30-300MHz	4.5 dB	4.4 dB	4.5 dB
300-1000MHz	4.3 dB	4.3 dB	4.3 dB
1GHz<	5.7 dB	5.7 dB	5.7 dB

Antenna port conducted test	
Below 1GHz	±0.4dB
1GHz and above	±0.7dB

Conducted Emission Test

The data listed in this test report has enough margin, more than site margin.

Radiated Emission Test

The data listed in this report meets the limits unless the uncertainty is taken into consideration.

3.5 Test Location

UL Japan, Inc. Yamakita EMC Lab.

907, Kawanishi, Yamakita-machi, Ashigarakami-gun, Kanagawa-ken 258-0124 JAPAN

Telephone number : +81 465 77 1011

Facsimile number : +81 465 77 2112

NVLAP Lab. code : 200441-0

No. 1 test site has been fully described in a report submitted to FCC office, and accepted on August 26, 2005 (Registration No.: 95486).

IC Registration No. : 2973B-1

No. 2 test site has been fully described in a report submitted to FCC office, and accepted on April 4, 2005 (Registration No.: 466226).

IC Registration No. : 2973B-3

No. 1 anechoic chamber has been fully described in a report submitted to FCC office, and accepted on November 2, 2005 (Registration No.: 95967).

IC Registration No. : 2973B-2

Test room	Width x Depth x Height (m)	Test room	Width x Depth x Height (m)
No.1 shielded room	8.0 x 5.0 x 2.5	No.1 Semi-anechoic chamber	10.0 x 7.5 x 5.7
No.2 shielded room	5.0 x 4.0 x 2.5		
No.3 shielded room	4.0 x 5.0 x 2.7		

Open test site	Maximum measurement distance
No.1 open test site	30m
No.2 open test site	10m

UL Japan, Inc.

YAMAKITA EMC LAB.

907 Kawanishi, Yamakita-machi, Ashigarakami-gun, Kanagawa-ken, 258-0124 JAPAN

Telephone: +81 465 77 1011 Facsimile: +81 465 77 2112

MF060b (18.06.07)

4 System Test Configuration

4.1 Justification

The system was configured in typical fashion (as a customer would normally use it) for testing.

Transmitting (IEEE802.11b (11Mbps))	-2412MHz (Low) -2437MHz (Middle) -2462MHz (High)
Transmitting (IEEE802.11g (54Mbps))	-2412MHz (Low) -2437MHz (Middle) -2462MHz (High)
Receiving (IEEE802.11b/g)	-2437MHz (Middle)

The EUT has an ability to provide some different modulation and data rates. Some of these modulation and data rates did not change in the spectrum envelopes of the EUT at conducted measurement with the antenna terminal. Therefore, the results of the final measurements were the IEEE 802.11b DSSS (CCK, 11Mbps) and IEEE 802.11g OFDM (64QAM, 54Mbps) modulation as the highest data rate.

4.2 Configuration of Tested System

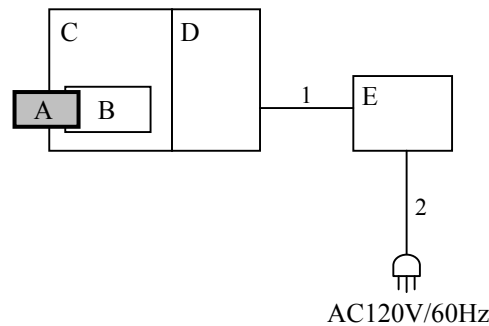

* Test data was taken under worst case conditions.

Description of EUT and support equipment

No.	Item	Model number	Serial number	Manufacturer	FCC ID (Remark)
A	Option(s) for Radiocommunications	R-WL54CG	61290054	RICOH	BBP-WLRW54G1 (EUT)
B	Extension board1	ABN105623	-	RICOH	(Jig)
C	Controller board	Type-DC	D0095742	RICOH	(Jig)
D	Extension board2	WBG226714	-	RICOH	(Jig)
E	PSU	MPT-400	2301218427	RICOH	(Jig)

List of cables used *1)

No.	Name	Length (m)	Shield		Remark
			Cable	Connector	
1	DC cable	0.7	Unshielded	Unshielded	-
2	AC cable	1.5	Unshielded	Unshielded	-

*1) All cables used for the measurement are exclusive use or marketed.

UL Japan, Inc.

YAMAKITA EMC LAB.

907 Kawanishi, Yamakita-machi, Ashigarakami-gun, Kanagawa-ken, 258-0124 JAPAN

Telephone: +81 465 77 1011

Facsimile: +81 465 77 2112

MF060b (18.06.07)

5 Conducted Emissions

5.1 Operating environment

The test was carried out in No.2 shielded room.

5.2 Test configuration

EUT was placed on a platform of nominal size, 1m by 1.8m, raised 80cm above the conducting ground plane. The rear of tabletop was located 40cm to the vertical conducting plane. The rear of peripherals was aligned and flushed with rear of tabletop. All other surfaces of tabletop were at least 80cm from any other grounded conducting surface. EUT was located 80cm from a Line Impedance Stabilization Network (LISN) and excess AC cable was bundled in center. A drawing of the set up is shown in the photos of Appendix 1.

5.3 Test conditions

Frequency range : 0.15 - 30MHz
EUT operation mode : Transmitting, Receiving

5.4 Test procedure

The PSU was connected to a LISN (AMN). An overview sweep with peak detection has been performed. The Conducted emission measurements were made with the following detector function of the test receiver.

Detector: QP/AV
IF Bandwidth: 9kHz

5.5 Results

Summary of the test results : Pass
Date : May 9, 2007 Test engineer : Toyokazu Imamura

6 6dB Bandwidth & Occupied Bandwidth (99%)

Test Procedure

The bandwidth was measured with a spectrum analyzer connected to the antenna port.

Summary of the test results: Pass
Date: May 29, 2007 Test engineer : Tatsuya Arai

7 Maximum Peak Output Power

Test Procedure

The Maximum Peak Output Power was measured with a power meter connected to the antenna port.

Summary of the test results: Pass
Date: May 22, 2007 Test engineer : Tatsuya Arai

8 Out of Band Emissions (Antenna Port Conducted)

Test Procedure

The Out of Band Emissions was measured with a spectrum analyzer connected to the antenna port.

Summary of the test results: Pass
Date: May 29, 2007 Test engineer : Tatsuya Arai

UL Japan, Inc.

YAMAKITA EMC LAB.

907 Kawanishi, Yamakita-machi, Ashigarakami-gun, Kanagawa-ken, 258-0124 JAPAN

Telephone: +81 465 77 1011 Facsimile: +81 465 77 2112

MF060b (18.06.07)

9 Out of Band Emissions (Radiated)

9.1 Operating environment

The test was carried out in No.1 anechoic chamber.

9.2 Test configuration

EUT was placed on a urethane platform of nominal size, 0.5m by 0.5m, raised 80cm above the conducting ground plane. A drawing of the set up is shown in the photos of Appendix 1.

9.3 Test conditions

Frequency range : 30MHz - 26.5GHz
 Test distance : 3m
 EUT operation mode : Transmitting, Receiving

9.4 Test procedure

The Radiated Electric Field Strength intensity has been measured with a ground plane and at a distance of 3m. The measuring antenna height was varied between 1 and 4m and EUT was rotated a full revolution in order to obtain the maximum value of the electric field intensity.

The measurements were performed for both vertical and horizontal antenna polarization.

In any 100kHz bandwidth outside the frequency band in which the spread spectrum intentional radiator is operating, the radio frequency power that is produced by the intentional radiator confirmed 20dB below that in the 100kHz bandwidth within the band that contains the highest level of the desired power, based on a radiated measurement.

Measurements were performed with QP, PK, and AV detector.

The radiated emission measurements were made with the following detector function of the test receiver.

When using Spectrum analyzer, the test was made with adjusting span to zero by using peak hold.

Frequency	Below 1GHz	Above 1GHz
Instrument used	Test Receiver	Spectrum Analyzer
Detector IF Bandwidth	QP: BW 120kHz	PK: RBW: 1MHz/VBW: 1MHz, AV: RBW: 1MHz/VBW: 10Hz
Measuring antenna	Biconical (30-300MHz) Logperiodic (300MHz-1GHz)	Horn

The equipment was previously checked at each position of three axes X, Y and Z. The position in which the maximum noise occurred was chosen to put into measurement. See the table below and photographs in page 13. With the position, the noise levels of all the frequencies were measured.

Frequency	Worst position
Below 1GHz	Horizontal: X, Vertical: Z
Above 1GHz	Horizontal: X, Vertical: X

9.5 Band edge

Band edge level at 2400MHz is less than 20dB of peak point of the carrier. Refer to the data of Out of Band Emissions (Antenna Port Conducted).

Band edge level at 2390MHz and 2483.5MHz is below the limits of FCC 15.209. Refer to the data of Radiated emission.

9.6 Results

Summary of the test results : Pass
 No noise was detected above the 5th order harmonics.

Date: May 10, 11 and 28, 2007

Test engineer : Toyokazu Imamura, Tatsuya Arai and Ichiro Isozaki

UL Japan, Inc.

YAMAKITA EMC LAB.

907 Kawanishi, Yamakita-machi, Ashigarakami-gun, Kanagawa-ken, 258-0124 JAPAN

Telephone: +81 465 77 1011

Facsimile: +81 465 77 2112

MF060b (18.06.07)

10 Peak Power Density

Test Procedure

The peak power density was measured with a spectrum analyzer connected to the antenna port.

Summary of the test results: Pass

Date: May 29, 2007

Test engineer : Tatsuya Arai

UL Japan, Inc.

YAMAKITA EMC LAB.

907 Kawanishi, Yamakita-machi, Ashigarakami-gun, Kanagawa-ken, 258-0124 JAPAN

Telephone: +81 465 77 1011

Facsimile: +81 465 77 2112

MF060b (18.06.07)

APPENDIX 1: Photographs of test setup

Page 11	:	Conducted emission
Page 12	:	Radiated emission
Page 13	:	Pre check of worse-case position

APPENDIX 2: Test Data

Page 14 - 24	:	Conducted emission
Page 25 - 26	:	6dB Bandwidth
Page 27	:	Maximum Peak Output Power
Page 28 - 41	:	Out of Band Emissions (Antenna Port Conducted)
Page 42 - 62	:	Out of Band Emissions (Radiated)
Page 63 - 65	:	Peak Power Density
Page 66 - 67	:	Occupied Bandwidth

APPENDIX 3: Test instruments

Page 68	:	Test instruments
---------	---	------------------

Conducted emission

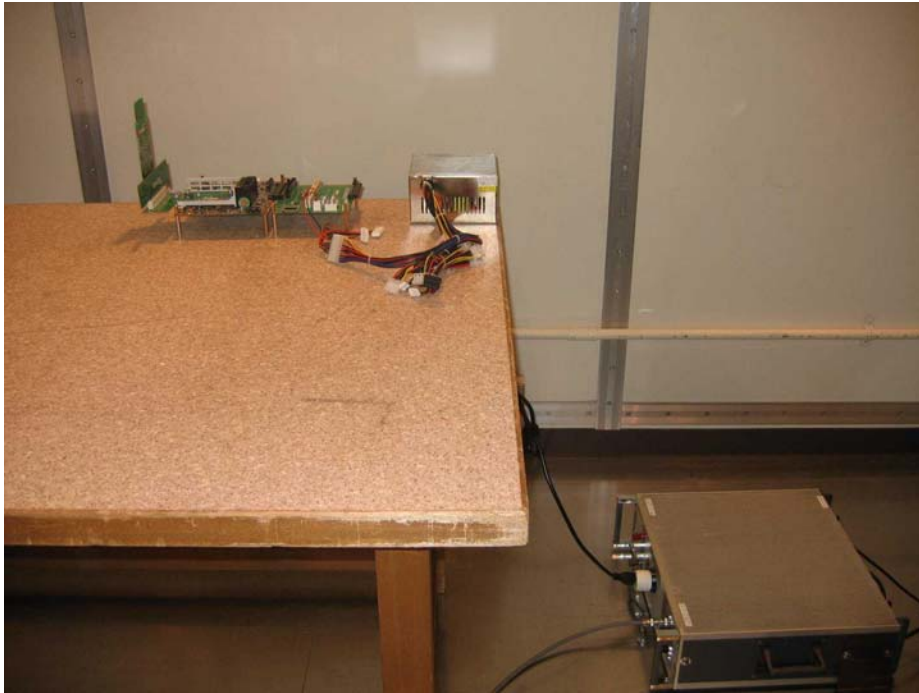

UL Japan, Inc.

YAMAKITA EMC LAB.

907 Kawanishi, Yamakita-machi, Ashigarakami-gun, Kanagawa-ken, 258-0124 JAPAN

Telephone: +81 465 77 1011

Facsimile: +81 465 77 2112

MF060b (18.06.07)

Radiated emission

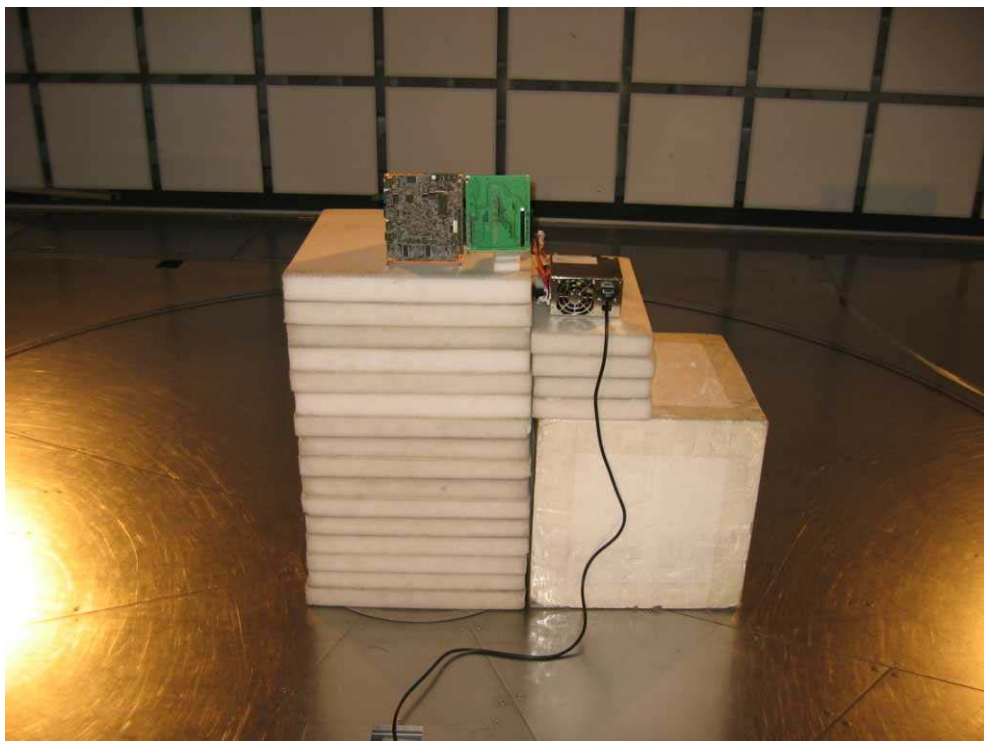
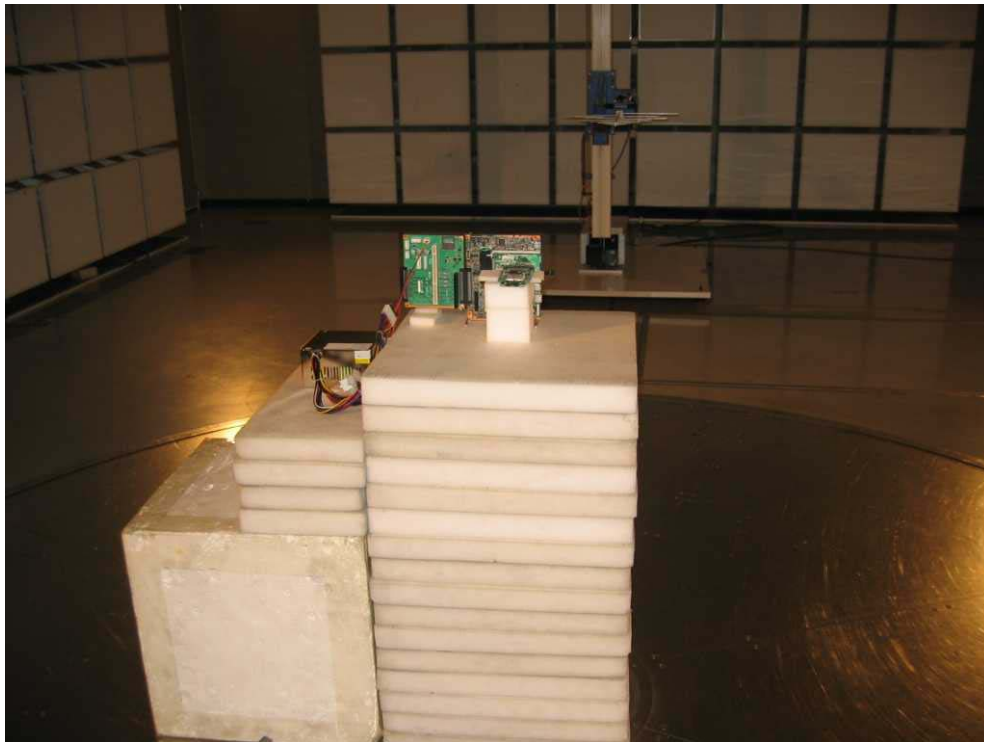

UL Japan, Inc.

YAMAKITA EMC LAB.

907 Kawanishi, Yamakita-machi, Ashigarakami-gun, Kanagawa-ken, 258-0124 JAPAN

Telephone: +81 465 77 1011

Facsimile: +81 465 77 2112

MF060b (18.06.07)

Pre-check of the worst position

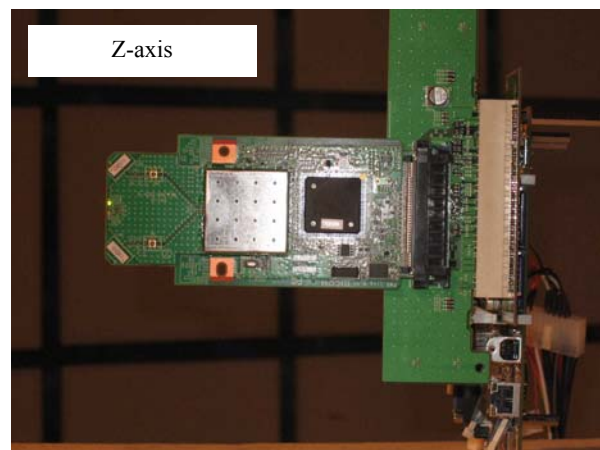
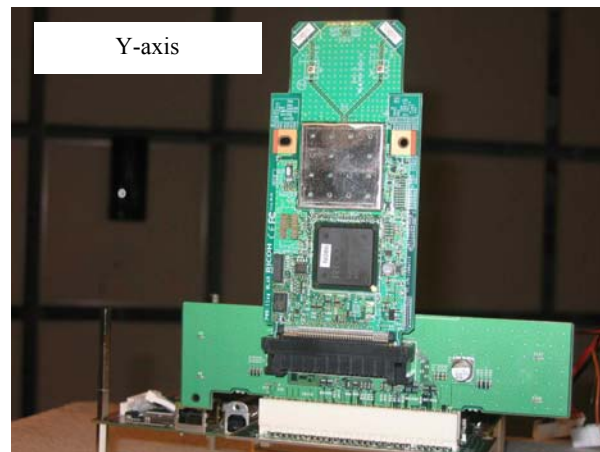
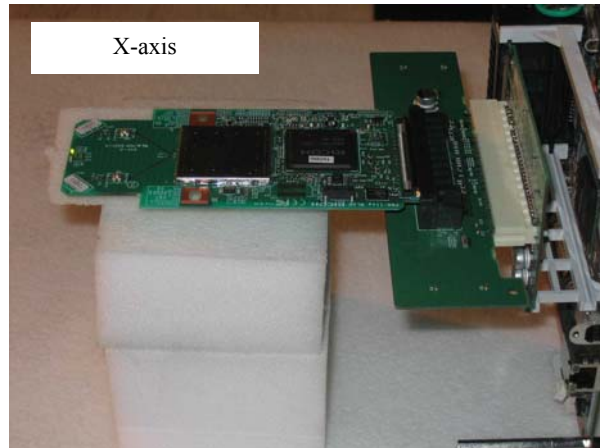

DATA OF CONDUCTION TEST

UL Japan, Inc.
YAMAKITA No.2 SHIELD ROOM
Report No. : 271E0337-YK-D

Applicant : RICOH COMPANY, LTD.
Kind of Equipment : Option(s) for Radiocommunications
Model No. : R-WL54CG
Serial No. : 61290054
Power : AC120V/60Hz
Mode : Transmitting (2412MHz)
Remarks : IEEE802.11b
Date : 5/9/2007
Phase : Single Phase
Temperature : 25 °C Engineer : Toyokazu Imamura
Humidity : 54 %
Regulation : FCC Part15C § 15.207. (CISPR Pub.22)

No.	FREQ. [MHz]	READING (N)		READING (L1)		LISN FACTOR [dB]	CABLE LOSS [dB]	ATTEN. [dB]	RESULT		LIMITS		MARGIN	
		QP [dB μV]	AV	QP [dB μV]	AV				QP [dB]	AV [dB μV]	QP [dB μV]	AV [dB μV]	QP [dB]	AV [dB]
1.	0.1546	36.0	-	36.7	-	0.1	0.1	0.0	36.9	-	65.7	55.7	28.8	-
2.	0.1811	38.2	-	40.4	-	0.1	0.1	0.0	40.6	-	64.4	54.4	23.8	-
3.	0.2627	39.7	-	36.5	-	0.1	0.1	0.0	39.9	-	61.3	51.3	21.4	-
4.	0.3141	36.4	-	34.2	-	0.1	0.1	0.0	36.6	-	59.9	49.9	23.3	-
5.	21.5179	35.6	-	36.0	-	0.5	0.7	0.0	37.2	-	60.0	50.0	22.8	-
6.	23.6294	35.7	30.6	36.2	31.0	0.5	0.7	0.0	37.4	32.2	60.0	50.0	22.6	17.8

CALCULATION: READING + LISN FACTOR + CABLE LOSS + ATTEN.

■ LISN : KLS-02 (NSLK8127) ■ COAXIAL CABLE : KCC-33/34
■ EMI RECEIVER : KTR-01 (ES140)

DATA OF CONDUCTION TEST

UL Japan, Inc.
YAMAKITA No.2 SHIELD ROOM
Report No. : 271E0337-YK-D

Applicant : RICOH COMPANY, LTD.
Kind of Equipment : Option(s) for Radiocommunications
Model No. : R-WL54CG
Serial No. : 61290054
Power : AC120V/60Hz
Mode : Transmitting (2412MHz)
Remarks : IEEE802.11b
Date : 5/9/2007
Phase : Single Phase
Temperature : 25 °C Engineer : Toyokazu Imamura
Humidity : 54 %
Regulation : FCC Part15C § 15.207. (CISPR Pub.22)

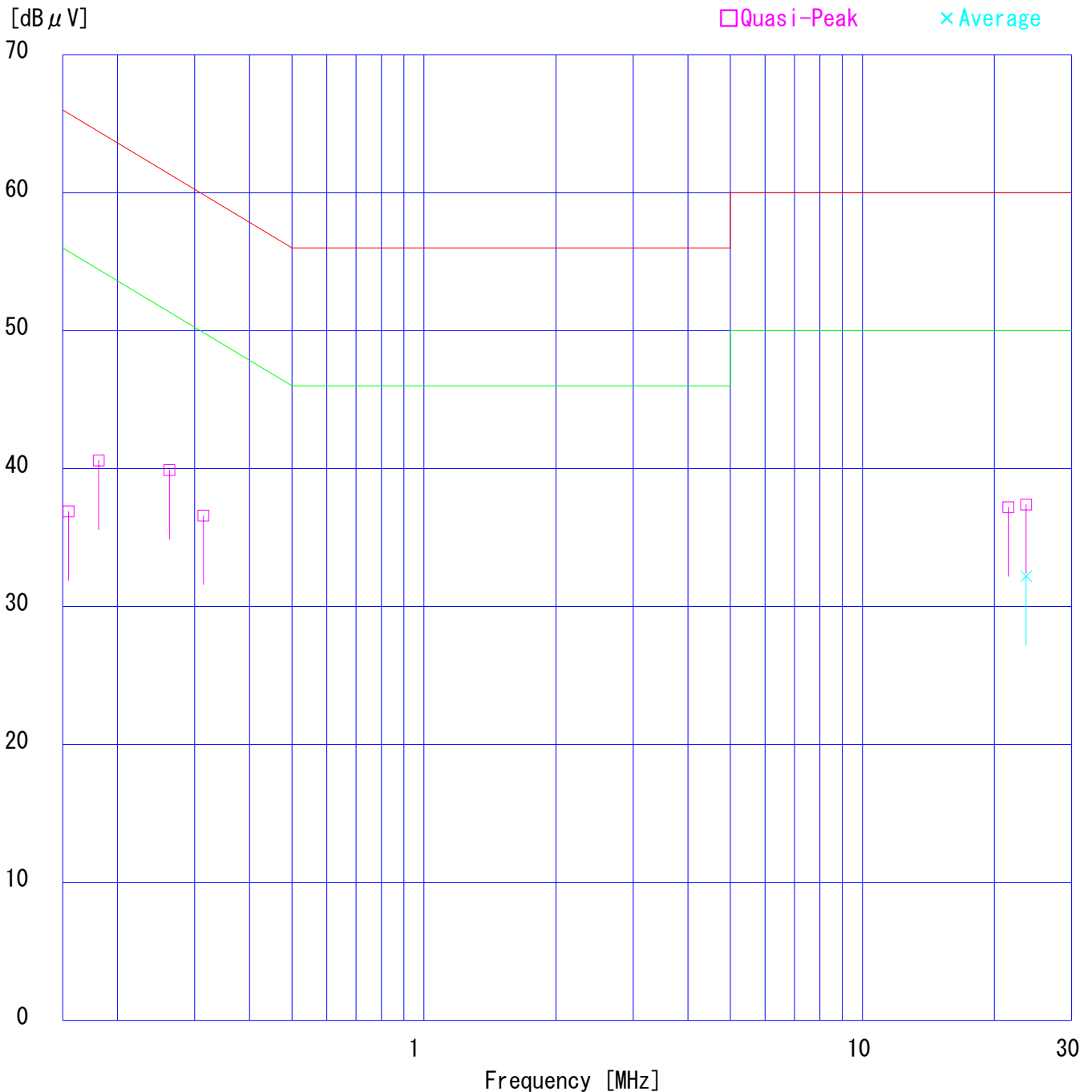

DATA OF CONDUCTION TEST CHART

UL Japan, Inc.
YAMAKITA No.2 SHIELD ROOM
Report No. : 271E0337-YK-D

Applicant : RICOH COMPANY, LTD.
Kind of Equipment : Option(s) for Radiocommunications
Model No. : R-WL54CG
Serial No. : 61290054
Power : AC120V/60Hz
Mode : Transmitting (2412MHz)
Remarks : IEEE802.11b
Date : 5/9/2007
Phase : Single Phase
Temperature : 25 °C
Humidity : 54 %
Regulation 1 : FCC Part15C § 15.207. (CISPR Pub.22)
Regulation 2 : None
Engineer : Toyokazu Imamura

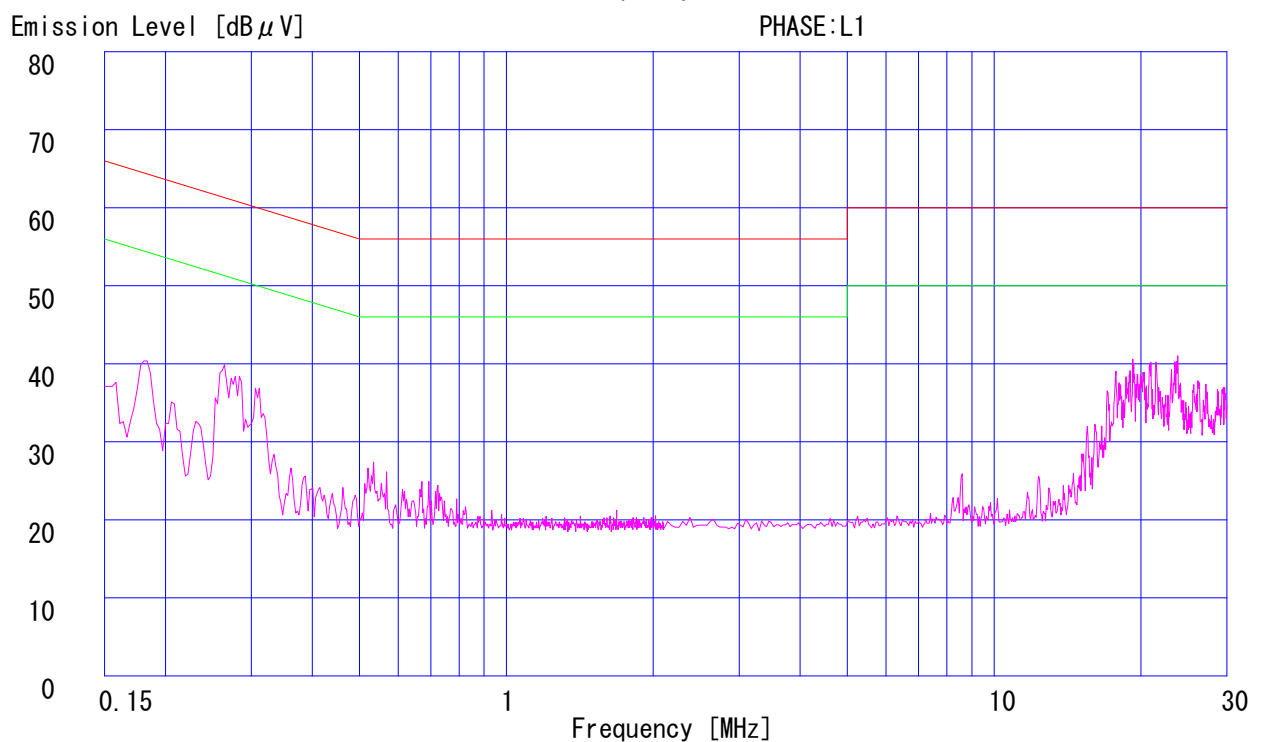
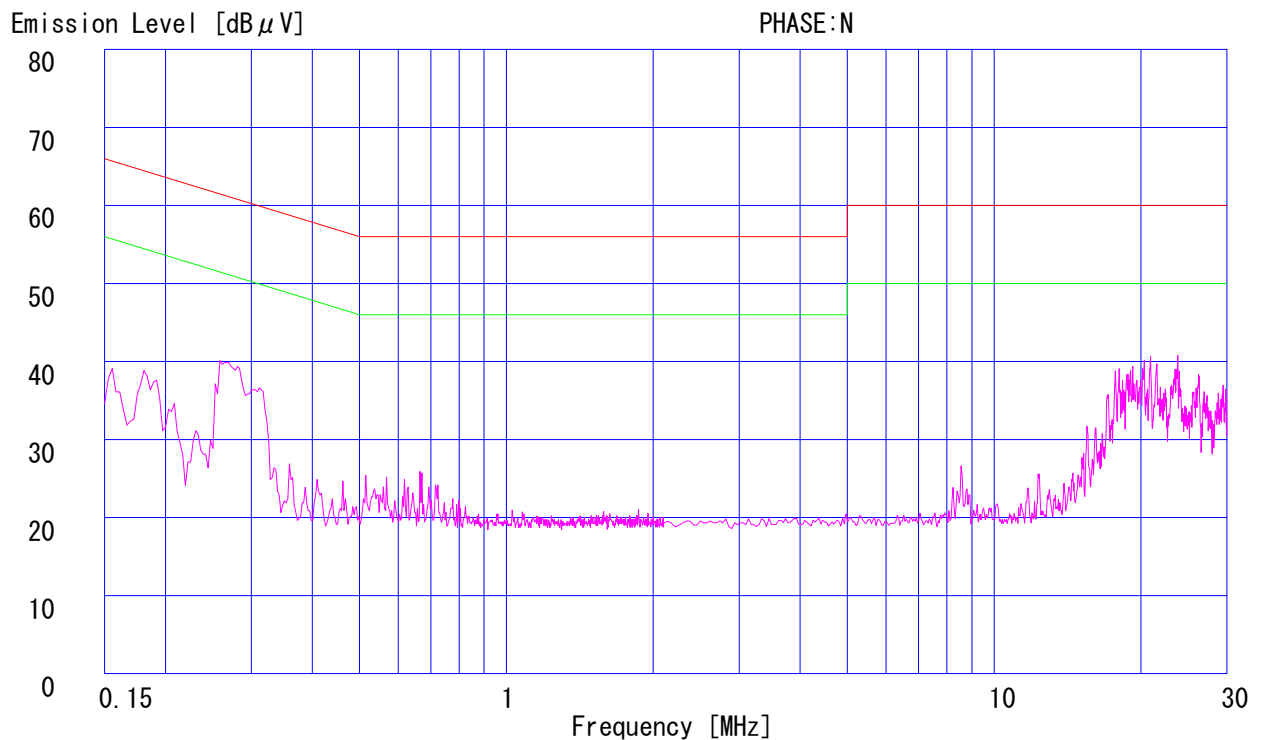

DATA OF CONDUCTION TEST CHART

UL Japan, Inc.
YAMAKITA No.2 SHIELD ROOM
Report No. : 271E0337-YK-D

Applicant : RICOH COMPANY, LTD.
Kind of Equipment : Option(s) for Radiocommunications
Model No. : R-WL54CG
Serial No. : 61290054
Power : AC120V/60Hz
Mode : Transmitting (2437MHz)
Remarks : IEEE802.11b
Date : 5/9/2007
Phase : Single Phase
Temperature : 25 °C
Humidity : 54 %
Regulation 1 : FCC Part15C § 15.207. (CISPR Pub.22)
Regulation 2 : None
Engineer : Toyokazu Imamura

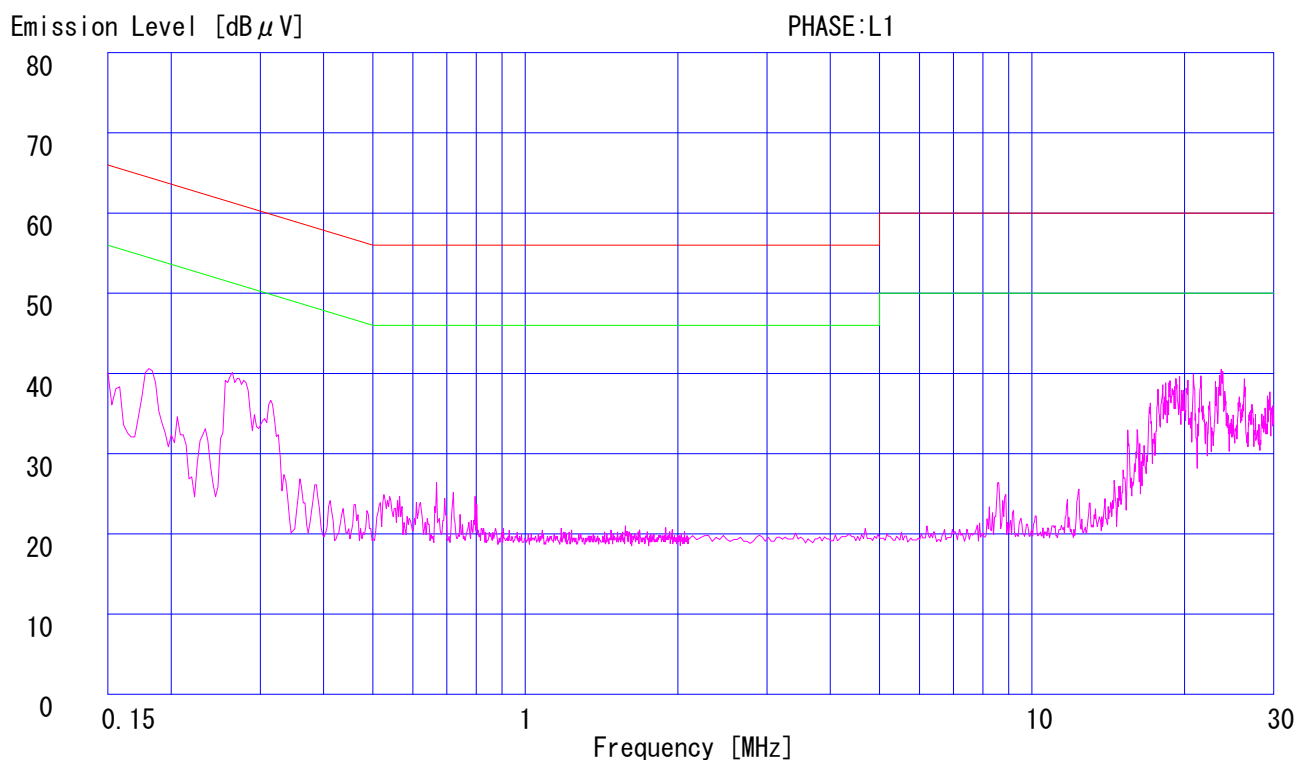
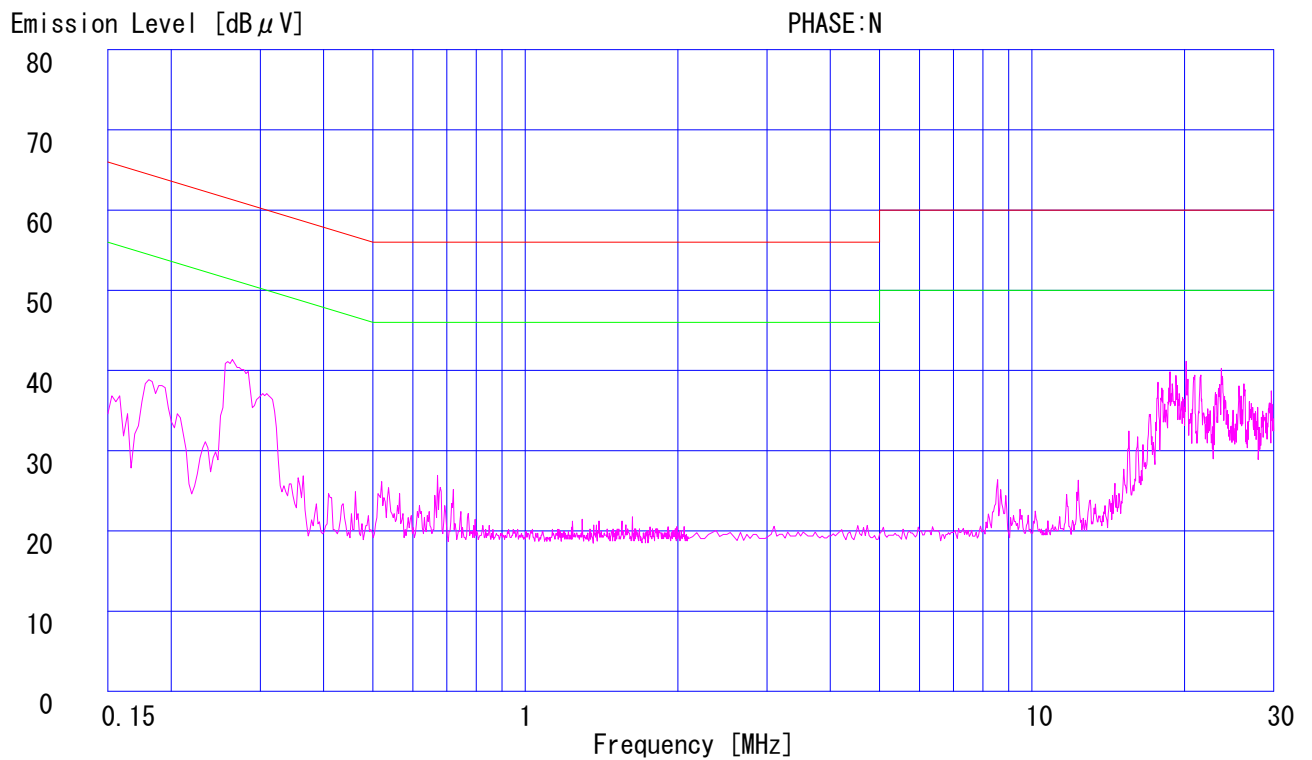

DATA OF CONDUCTION TEST CHART

UL Japan, Inc.
YAMAKITA No.2 SHIELD ROOM
Report No. : 271E0337-YK-D

Applicant : RICOH COMPANY, LTD.
Kind of Equipment : Option(s) for Radiocommunications
Model No. : R-WL54CG
Serial No. : 61290054
Power : AC120V/60Hz
Mode : Transmitting (2462MHz)
Remarks : IEEE802.11b
Date : 5/9/2007
Phase : Single Phase
Temperature : 25 °C
Humidity : 54 %
Regulation 1 : FCC Part15C § 15.207. (CISPR Pub.22)
Regulation 2 : None
Engineer : Toyokazu Imamura

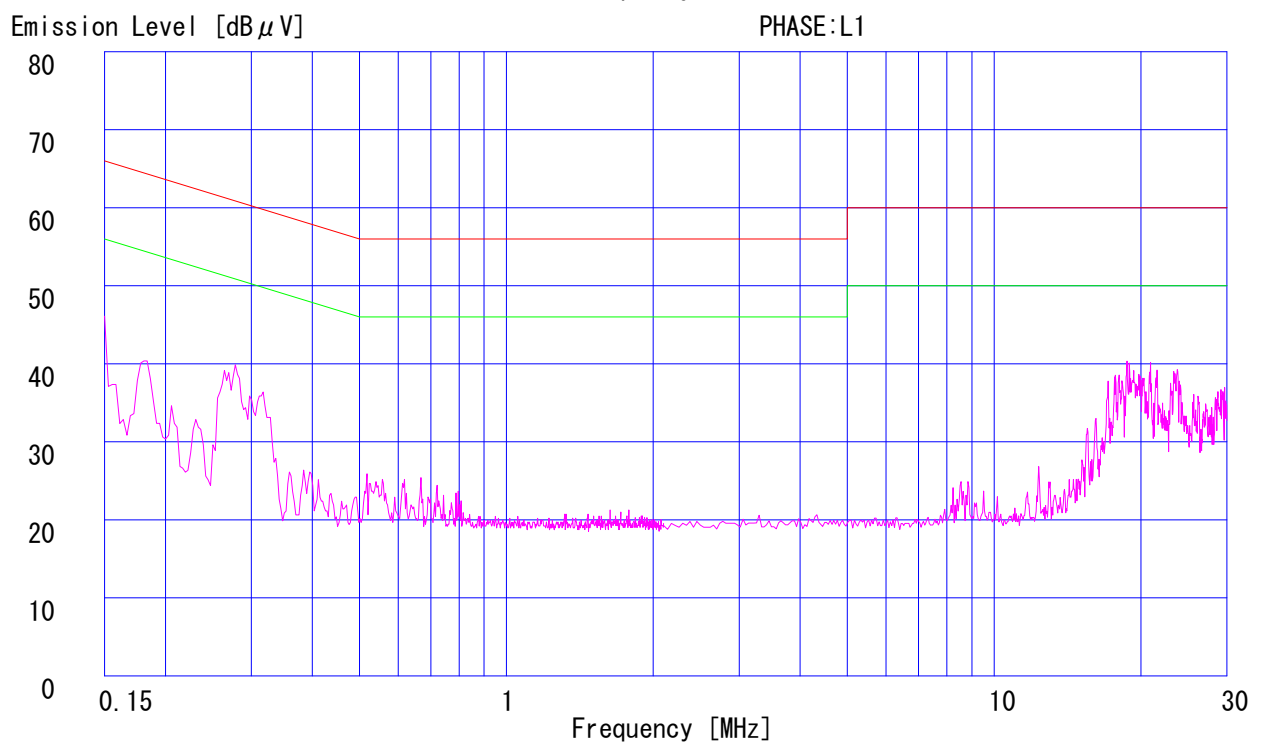
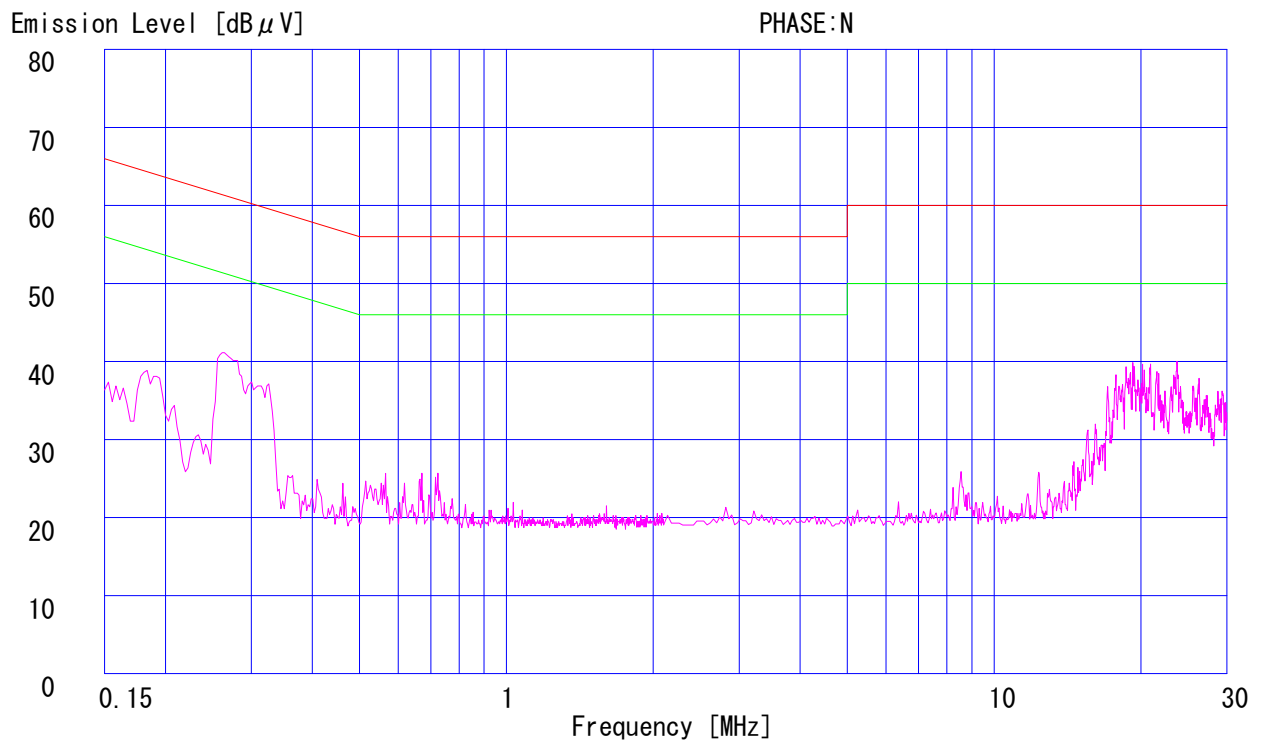

DATA OF CONDUCTION TEST

UL Japan, Inc.
YAMAKITA No.2 SHIELD ROOM
Report No. : 271E0337-YK-D

Applicant : RICOH COMPANY, LTD.
Kind of Equipment : Option(s) for Radiocommunications
Model No. : R-WL54CG
Serial No. : 61290054
Power : AC120V/60Hz
Mode : Transmitting (2412MHz)
Remarks : IEEE802.11g
Date : 5/9/2007
Phase : Single Phase
Temperature : 25 °C Engineer : Toyokazu Imamura
Humidity : 54 %
Regulation : FCC Part15C § 15.207. (CISPR Pub.22)

No.	FREQ. [MHz]	READING (N)		READING (L1)		LISN FACTOR [dB]	CABLE LOSS [dB]	ATTEN. [dB]	RESULT		LIMITS		MARGIN	
		QP [dB μV]	AV	QP [dB μV]	AV				QP [dB]	AV [dB μV]	QP [dB μV]	AV [dB μV]	QP [dB]	AV [dB]
1.	0.1546	35.5	-	36.1	-	0.1	0.1	0.0	36.3	-	65.7	55.7	29.4	-
2.	0.1813	38.0	-	37.8	-	0.1	0.1	0.0	38.2	-	64.4	54.4	26.2	-
3.	0.2629	40.0	22.5	37.2	19.7	0.1	0.1	0.0	40.2	22.7	61.3	51.3	21.1	28.6
4.	0.3152	36.5	31.1	34.7	28.5	0.1	0.1	0.0	36.7	31.3	59.8	49.8	23.1	18.5
5.	21.5193	32.4	-	33.0	-	0.5	0.7	0.0	34.2	-	60.0	50.0	25.8	-
6.	23.6291	35.3	-	35.4	30.3	0.5	0.7	0.0	36.6	31.5	60.0	50.0	23.4	18.5

CALCULATION: READING + LISN FACTOR + CABLE LOSS + ATTEN.

■ LISN :KLS-02 (NSLK8127) ■ COAXIAL CABLE :KCC-33/34
■ EMI RECEIVER :KTR-01 (ES140)

DATA OF CONDUCTION TEST

UL Japan, Inc.
YAMAKITA No.2 SHIELD ROOM
Report No. : 271E0337-YK-D

Applicant : RICOH COMPANY, LTD.
Kind of Equipment : Option(s) for Radiocommunications
Model No. : R-WL54CG
Serial No. : 61290054
Power : AC120V/60Hz
Mode : Transmitting (2412MHz)
Remarks : IEEE802.11g
Date : 5/9/2007
Phase : Single Phase
Temperature : 25 °C Engineer : Toyokazu Imamura
Humidity : 54 %
Regulation : FCC Part15C § 15.207. (CISPR Pub.22)

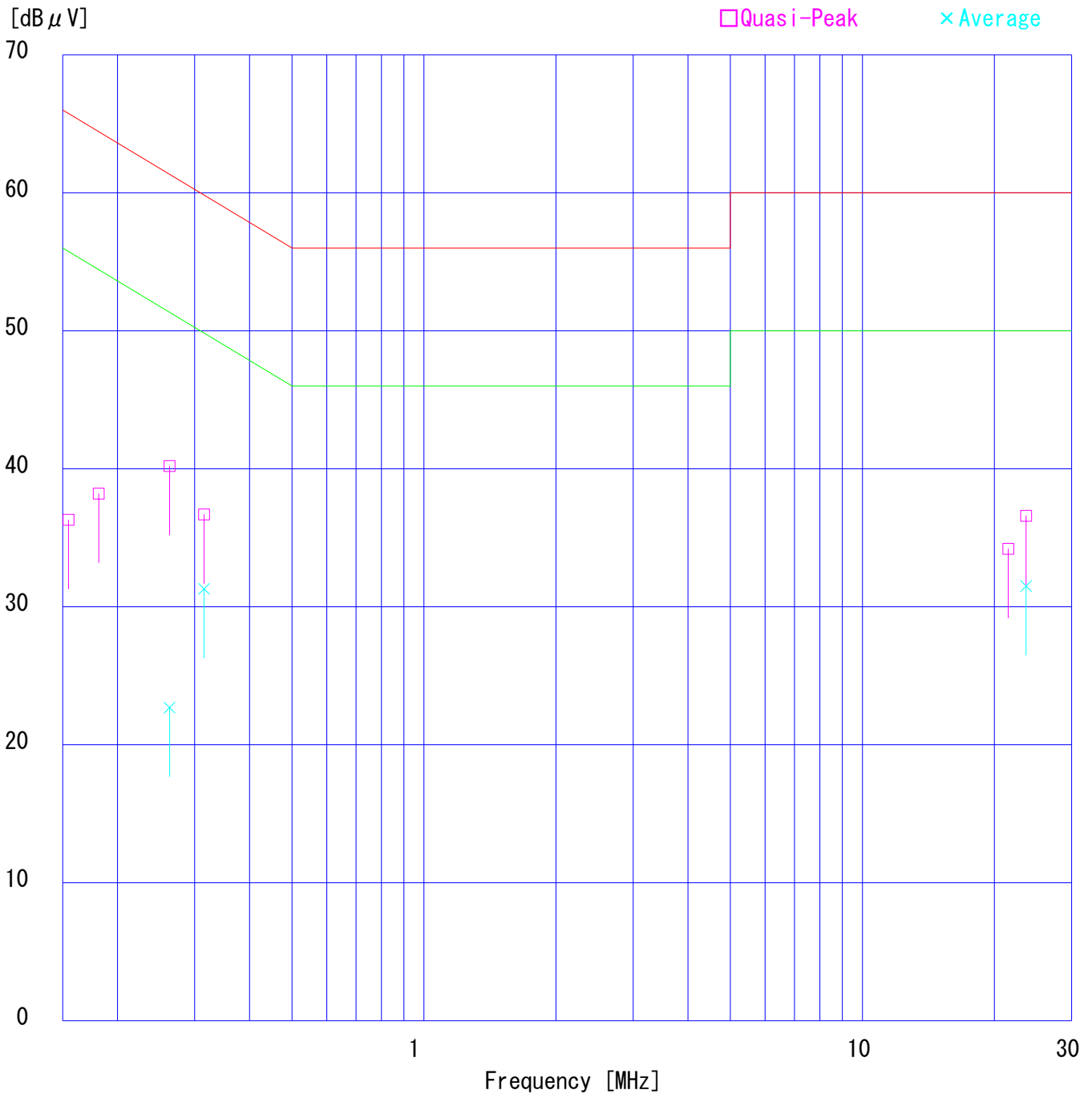

DATA OF CONDUCTION TEST CHART

UL Japan, Inc.
YAMAKITA No.2 SHIELD ROOM
Report No. : 271E0337-YK-D

Applicant : RICOH COMPANY, LTD.
Kind of Equipment : Option(s) for Radiocommunications
Model No. : R-WL54CG
Serial No. : 61290054
Power : AC120V/60Hz
Mode : Transmitting (2412MHz)
Remarks : IEEE802.11g
Date : 5/9/2007
Phase : Single Phase
Temperature : 25 °C
Humidity : 54 %
Regulation 1 : FCC Part15C § 15.207. (CISPR Pub.22)
Regulation 2 : None
Engineer : Toyokazu Imamura

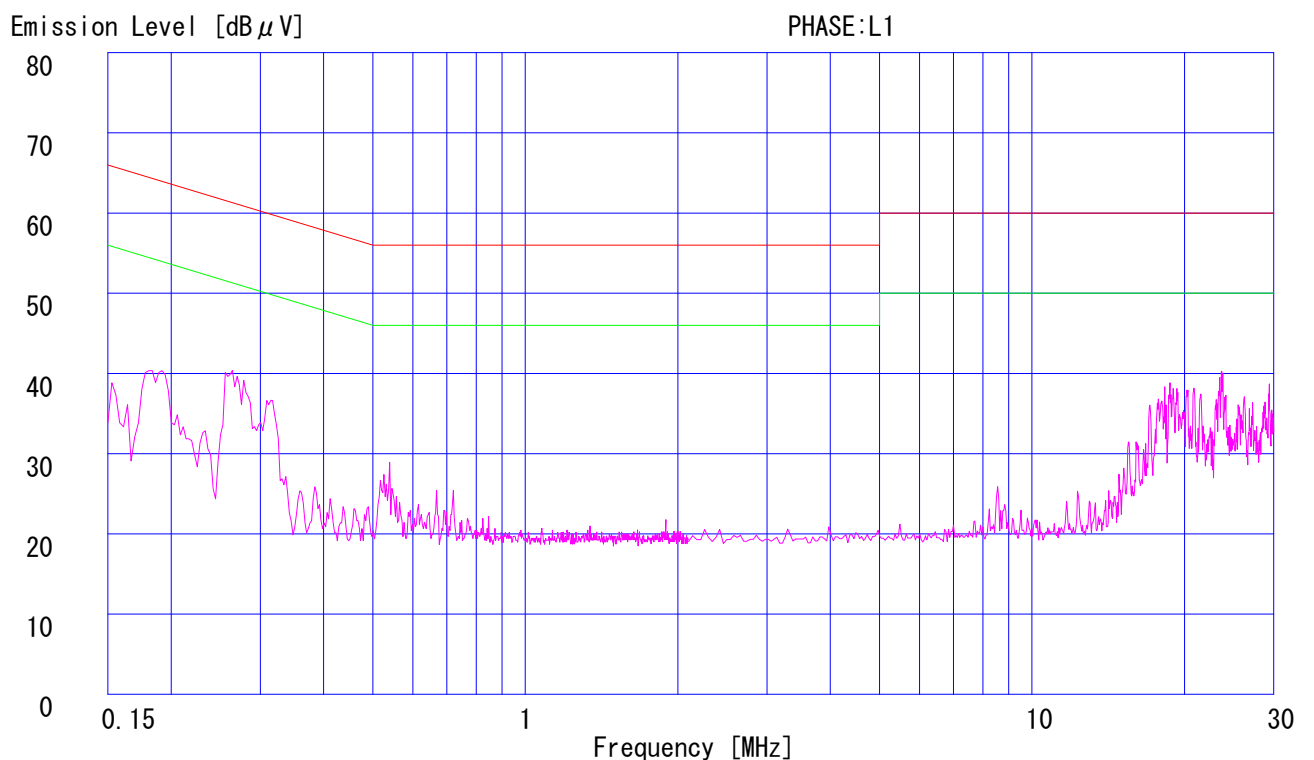
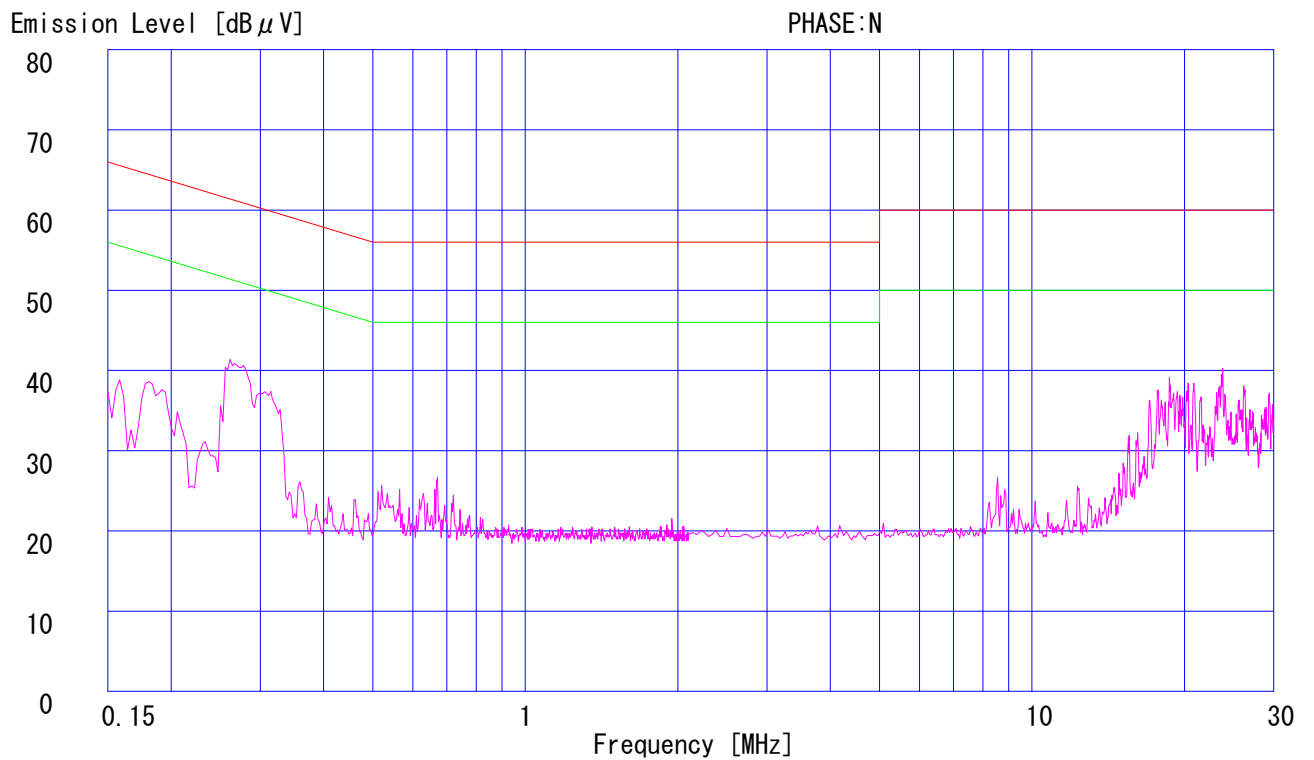

DATA OF CONDUCTION TEST CHART

UL Japan, Inc.
YAMAKITA No.2 SHIELD ROOM
Report No. : 271E0337-YK-D

Applicant : RICOH COMPANY, LTD.
Kind of Equipment : Option(s) for Radiocommunications
Model No. : R-WL54CG
Serial No. : 61290054
Power : AC120V/60Hz
Mode : Transmitting (2437MHz)
Remarks : IEEE802.11g
Date : 5/9/2007
Phase : Single Phase
Temperature : 25 °C
Humidity : 54 %
Regulation 1 : FCC Part15C § 15.207. (CISPR Pub.22)
Regulation 2 : None
Engineer : Toyokazu Imamura

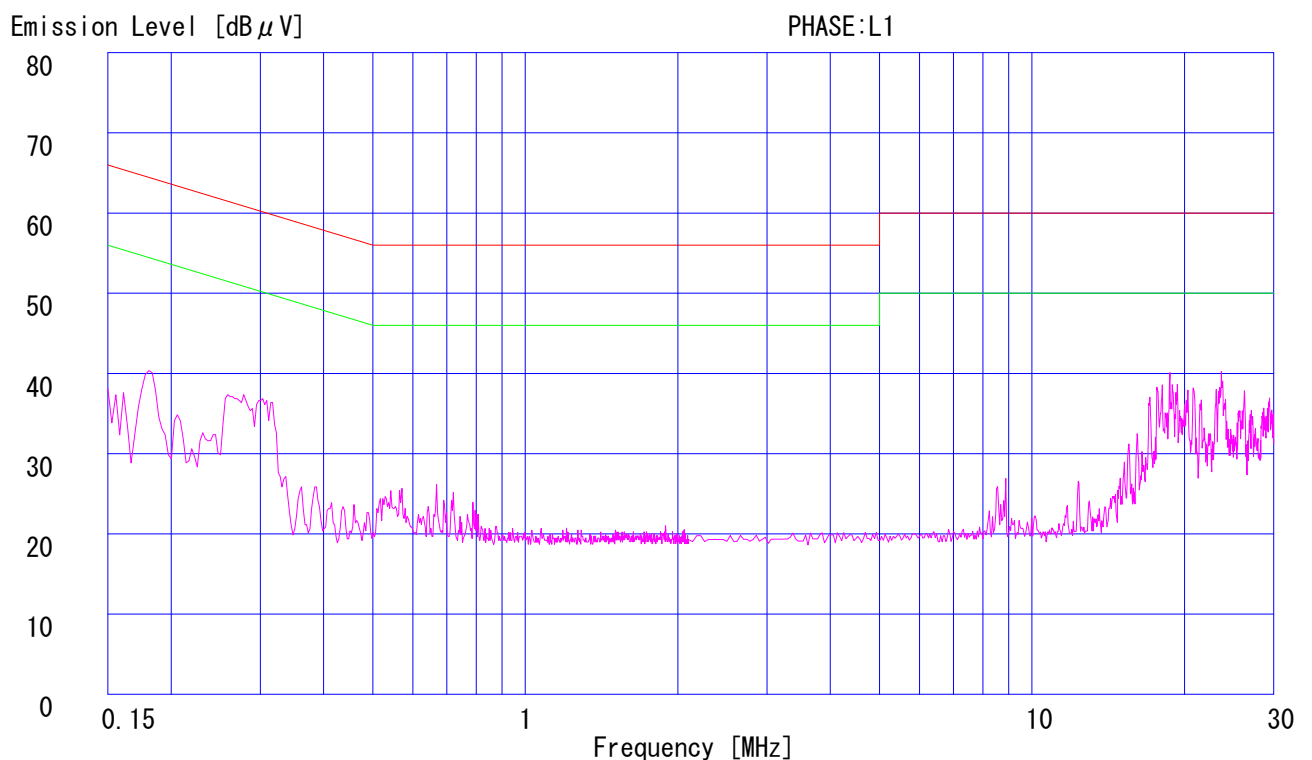
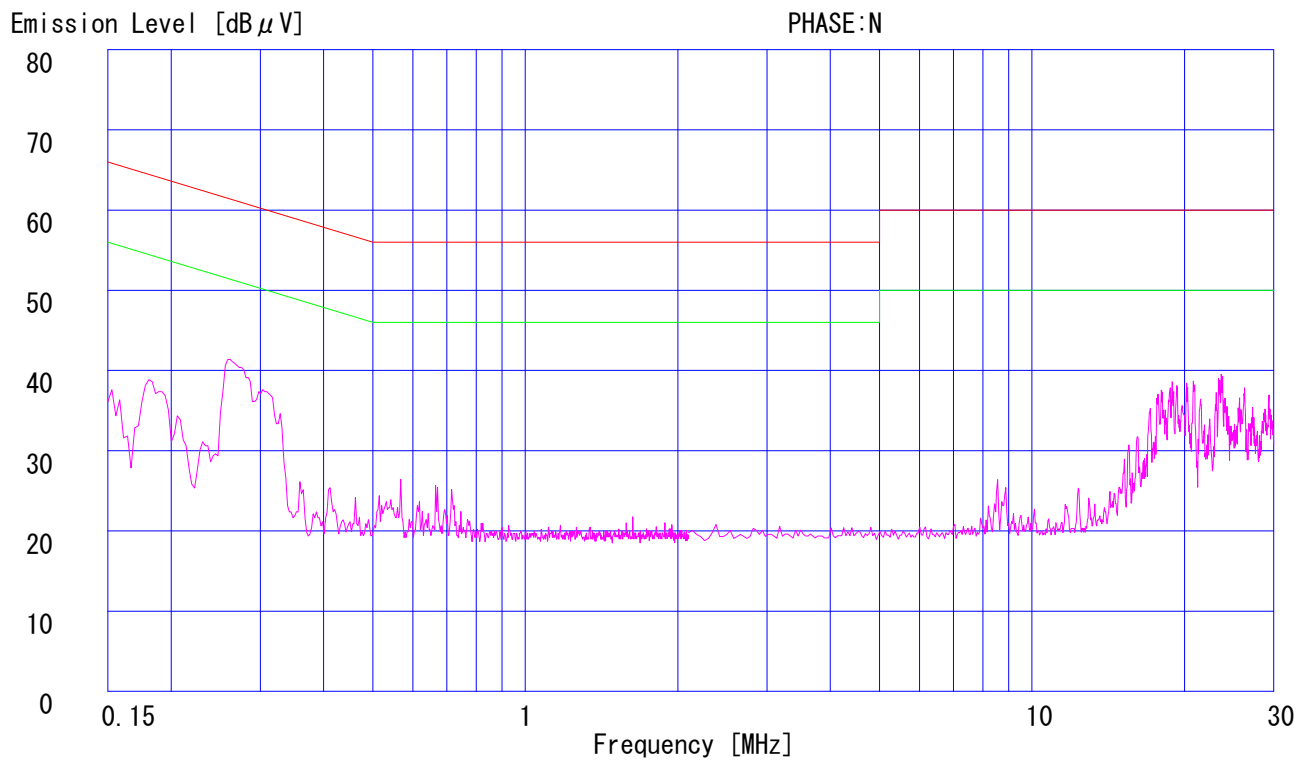

DATA OF CONDUCTION TEST CHART

UL Japan, Inc.
YAMAKITA No.2 SHIELD ROOM
Report No. : 271E0337-YK-D

Applicant : RICOH COMPANY, LTD.
Kind of Equipment : Option(s) for Radiocommunications
Model No. : R-WL54CG
Serial No. : 61290054
Power : AC120V/60Hz
Mode : Transmitting (2462MHz)
Remarks : IEEE802.11g
Date : 5/9/2007
Phase : Single Phase
Temperature : 25 °C
Humidity : 54 %
Regulation 1 : FCC Part15C § 15.207. (CISPR Pub.22)
Regulation 2 : None
Engineer : Toyokazu Imamura

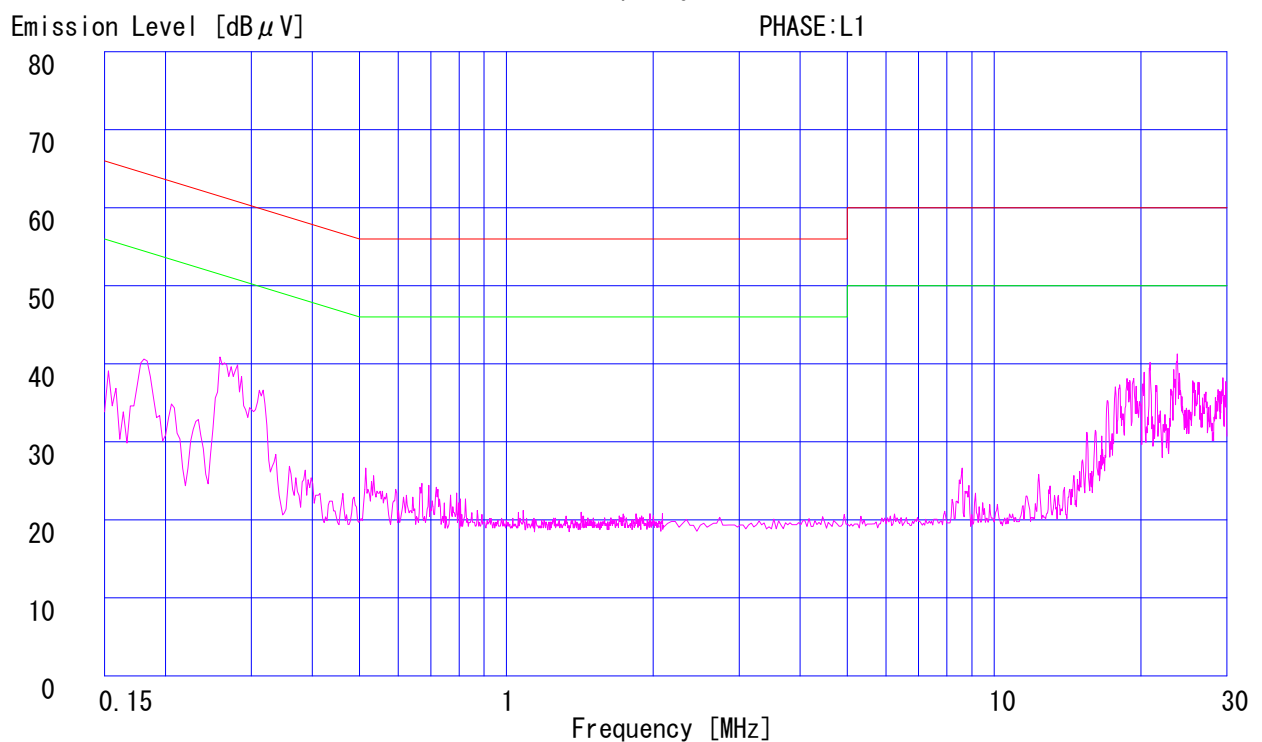
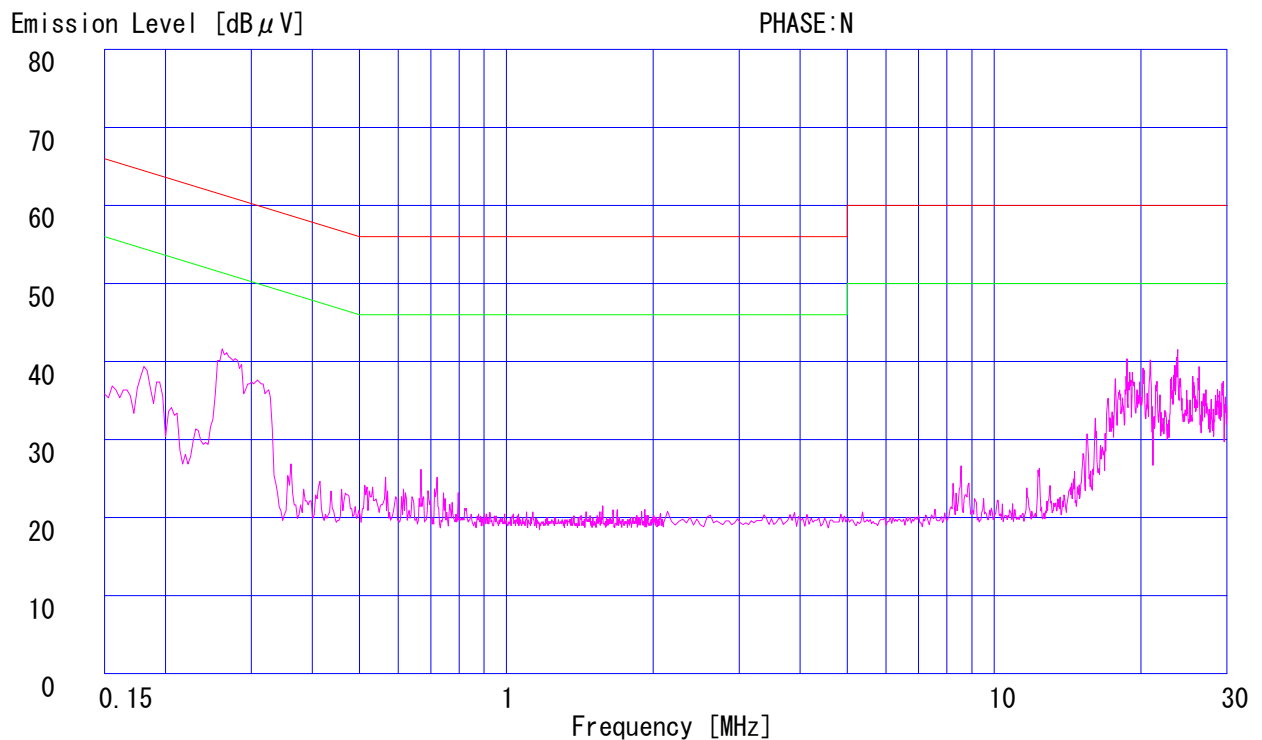

DATA OF CONDUCTION TEST CHART

UL Japan, Inc.
YAMAKITA No.2 SHIELD ROOM
Report No. : 271E0337-YK-D

Applicant : RICOH COMPANY, LTD.
Kind of Equipment : Option(s) for Radiocommunications
Model No. : R-WL54CG
Serial No. : 61290054
Power : AC120V/60Hz
Mode : Receiving (2437MHz)
Remarks : IEEE802.11b/g
Date : 5/9/2007
Phase : Single Phase
Temperature : 25 °C
Humidity : 54 %
Regulation 1 : FCC Part15B CLASS B (CISPR Pub. 22)
Regulation 2 : None
Engineer : Toyokazu Imamura

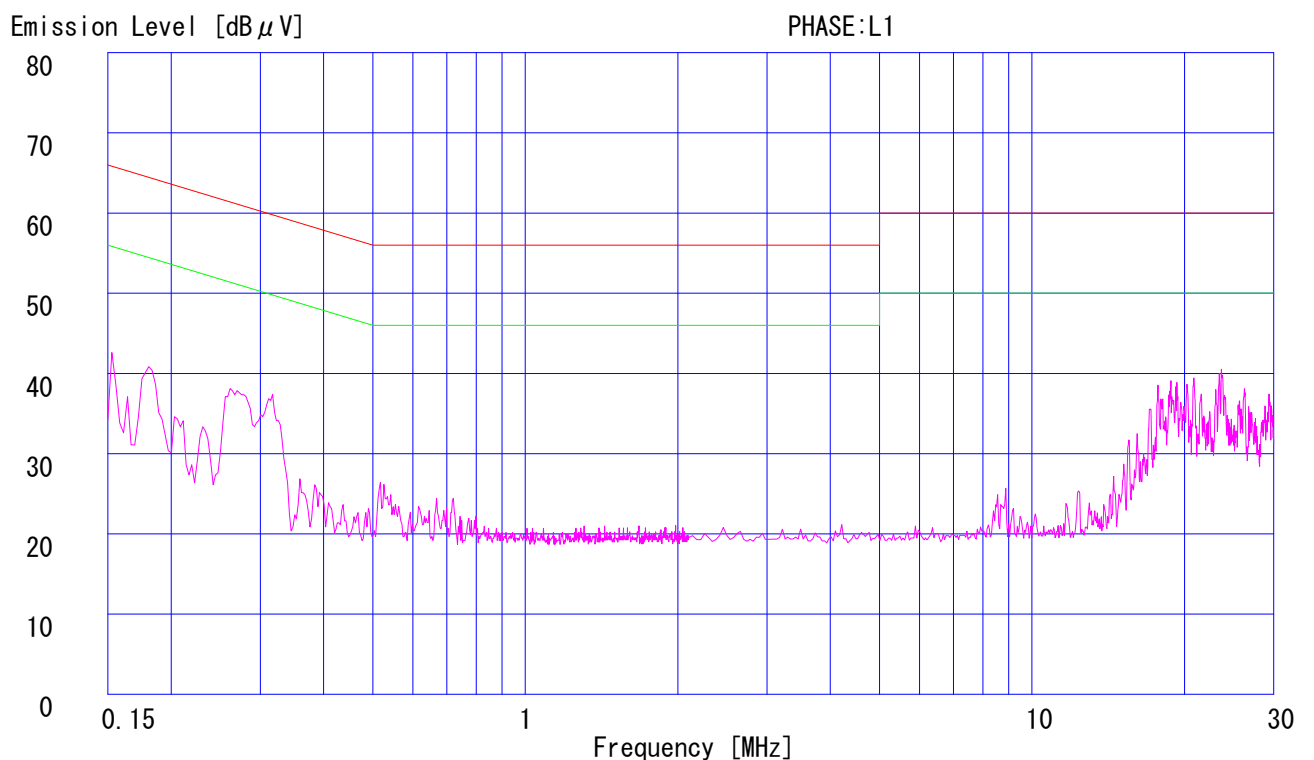
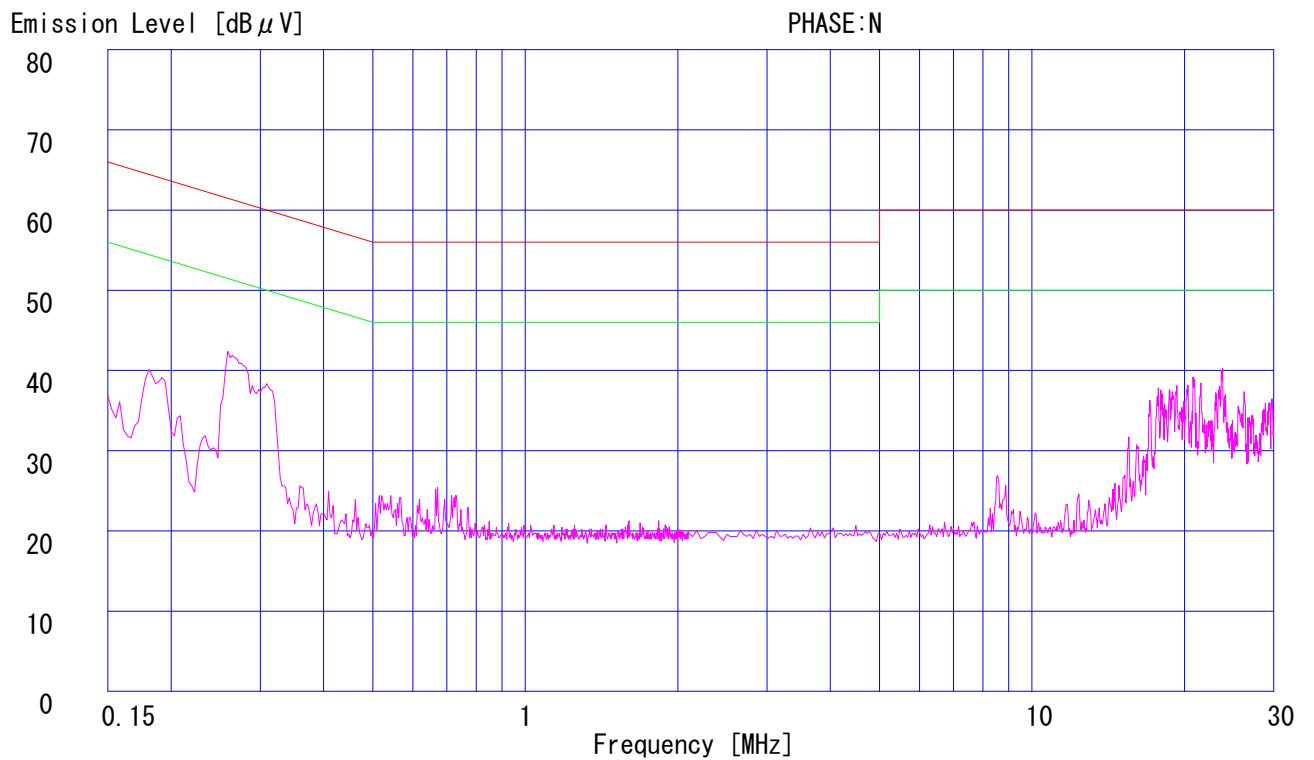

6dB Bandwidth: FCC 15.247(a)(2)

COMPANY : RICOH COMPANY, LTD
EQUIPMENT : Option(s) for Radiocommunications
MODEL NUMBER : R-WL54CG
SERIAL NUMBER : 61290054
FCC ID : BBP-WLRW54G1
POWER : AC120V/60Hz
 [IEEE802.11b(11Mbps)]

UL Japan, Inc. Yamakita No.2 Shielded Room
REPORT NO : 27IE0337-YK-D
REGULATION : Fcc Part15SubpartC 247(a)(2)
DATE : 2007/05/29
TEMP./HUMI : 25°C/42%
TEST MODE : Transmitting
ENGINEER : Tatsuya Arai

1. ch 1: 2412MHz/6dB Bandwidth:11.06MHz

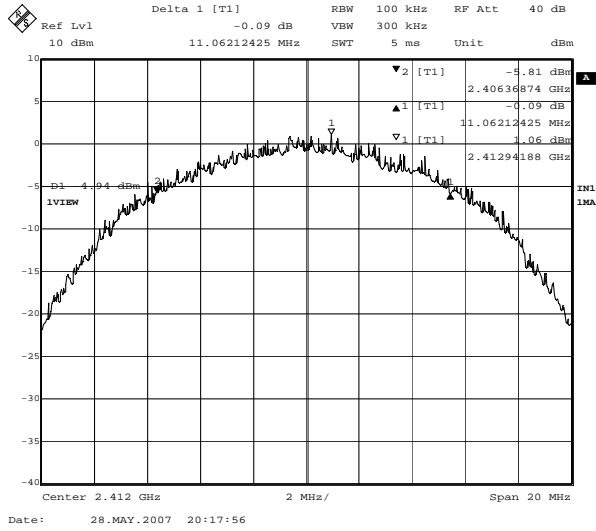

2. ch 6: 2437MHz/6dB Bandwidth:11.54MHz

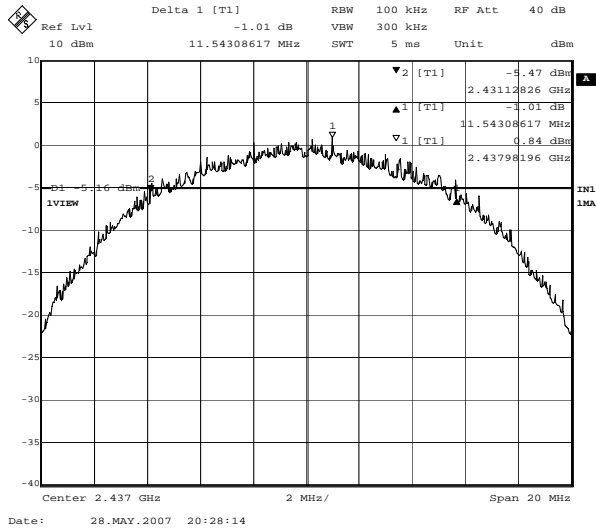

3. ch 11: 2462MHz/6dB Bandwidth:11.66MHz

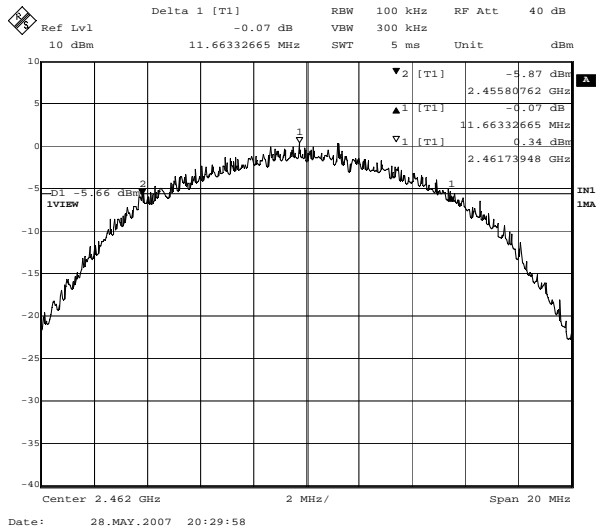

6dB Bandwidth: FCC 15.247(a)(2)

COMPANY : RICOH COMPANY, LTD
EQUIPMENT : Option(s) for Radiocommunications
MODEL NUMBER : R-WL54CG
SERIAL NUMBER : 61290054
FCC ID : BBP-WLRW54G1
POWER : AC120V/60Hz
 [IEEE802.11g(54Mbps)]

UL Japan, Inc. Yamakita No.2 Shielded Room
REPORT NO : 27IE0337-YK-D
REGULATION : Fcc Part15SubpartC 247(a)(2)
DATE : 2007/05/29
TEMP./HUMI : 25°C/42%
TEST MODE : Transmitting
ENGINEER : Tatsuya Arai

1. ch 1: 2412MHz/6dB Bandwidth:16.55MHz

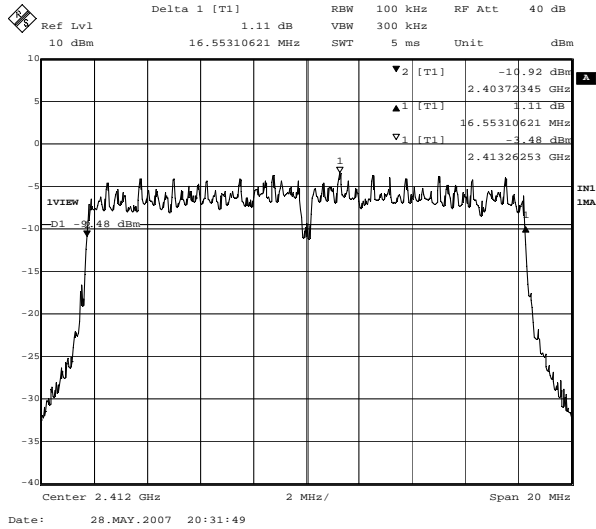

2. ch 6: 2437MHz/6dB Bandwidth:16.55MHz

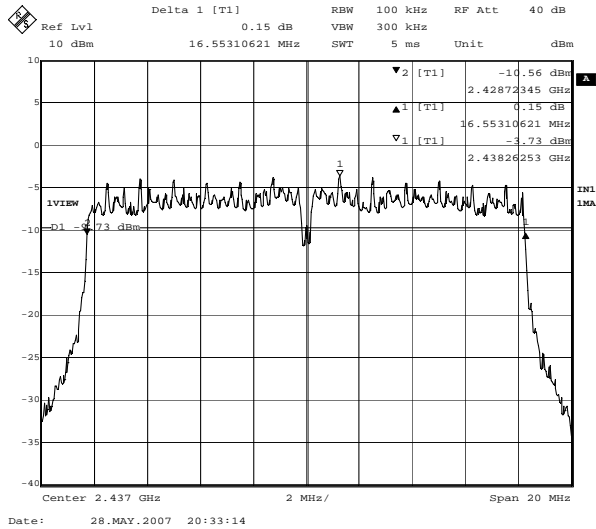

3. ch 11: 2462MHz/6dB Bandwidth:16.55MHz

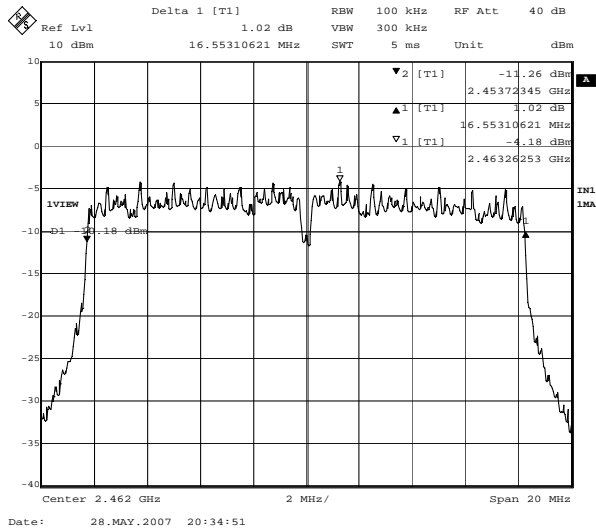

Maximum Peak Conducted Output Power

UL Japan, Inc.
YAMAKITA NO.2 Shielded Room

COMPANY : RICOH COMPANY, LTD
EQUIPMENT : Option(s) for Radiocommunications
MODEL NUMBER: R-WL54CG
SERIAL NUMBER: 61290054
FCC ID : BBP-WLRW54G1
POWER : AC120V/60Hz
TEST MODE : Transmitting

REPORT NO : 27IE0337-YK-D
REGULATION : Fcc Part15SubpartC 247(b)(3)
DATE : 2007/05/22
TEMP./HUMI : 24°C/53%

ENGINEER : Tatsuya Arai

IEEE802.11b(11Mbps)

CH	FREQ [GHz]	PM Reading [dBm]	Cable Loss [dB]	Results [dBm]	Limit (1W) [dBm]	MARGIN [dB]
Low	2412.00	14.60	1.3	15.90	30.0	14.10
Mid	2437.00	14.49	1.3	15.79	30.0	14.21
High	2462.00	13.61	1.3	14.91	30.0	15.09

IEEE802.11g(54Mbps)

CH	FREQ [GHz]	PM Reading [dBm]	Cable Loss [dB]	Results [dBm]	Limit (1W) [dBm]	MARGIN [dB]
Low	2412.00	19.32	1.3	20.62	30.0	9.38
Mid	2437.00	18.96	1.3	20.26	30.0	9.74
High	2462.00	18.13	1.3	19.43	30.0	10.57

Sample Calculation:

Result = Reading + Cable Loss

Out of Band Emission(Antenna Terminal Conducted): FCC 15.247(d)

COMPANY : RICOH COMPANY, LTD
EQUIPMENT : Option(s) for Radiocommunications
MODEL NUMBER: R-WL54CG
SERIAL NUMBER: 61290054
FCC ID : BBP-WLRW54G1
POWER : AC120V/60Hz

UL Japan, Inc. Yamakita No.2 Shielded Room
REPORT NO : 27IE0337-YK-D
REGULATION : Fcc Part15SubpartC 247(d)
DATE : 2007/05/29
TEMP./HUMI : 25deg.C./42%
Test Mode : Transmitting/Receiving
ENGINEER : Tatsuya Arai

[IEEE802.11b(11Mbps)]
Transmitting Ch1:2412MHz

1.

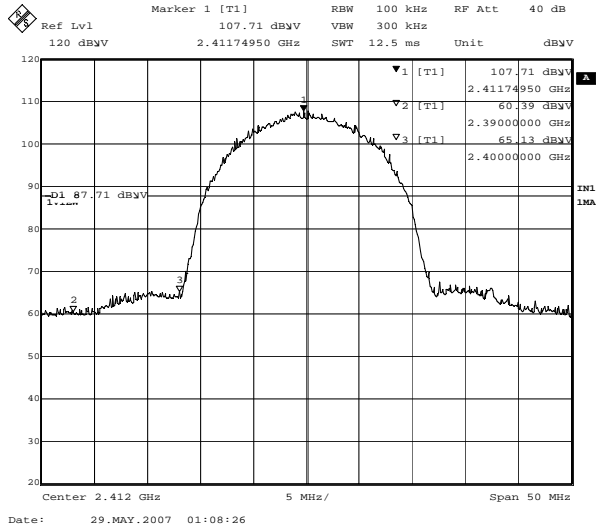

2.

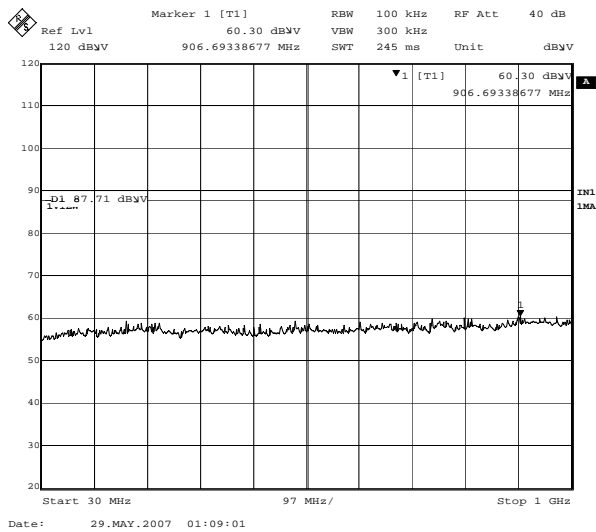

3.

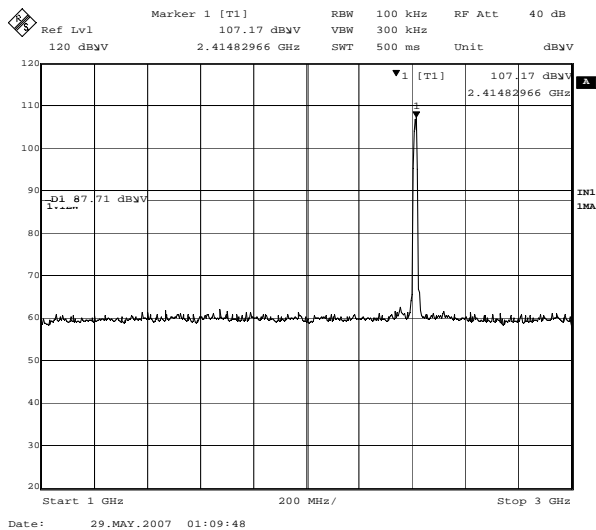

Out of Band Emission(Antenna Terminal Conducted): FCC 15.247(d)

COMPANY : RICOH COMPANY, LTD
EQUIPMENT : Option(s) for Radiocommunications
MODEL NUMBER: R-WL54CG
SERIAL NUMBER: 61290054
FCC ID : BBP-WLRW54G1
POWER : AC120V/60Hz

UL Japan, Inc. Yamakita No.2 Shielded Room
REPORT NO : 27IE0337-YK-D
REGULATION : Fcc Part15SubpartC 247(d)
DATE : 2007/05/29
TEMP./HUMI : 25deg.C./42%
Test Mode : Transmitting/Receiving
ENGINEER : Tatsuya Arai

[IEEE802.11b(11Mbps)]
Transmitting Ch1:2412MHz

4.

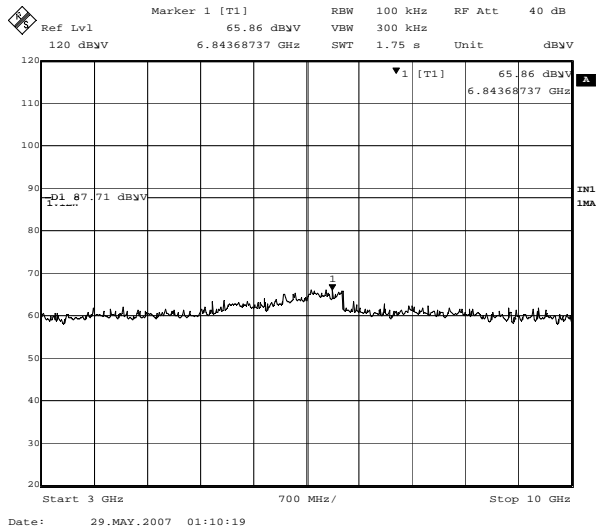

5.

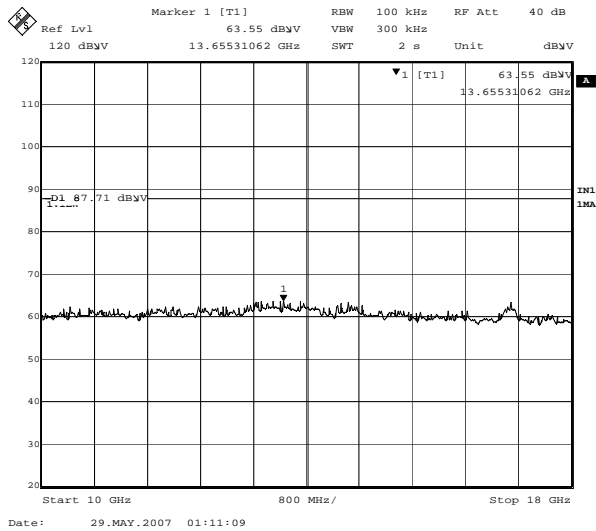

6.

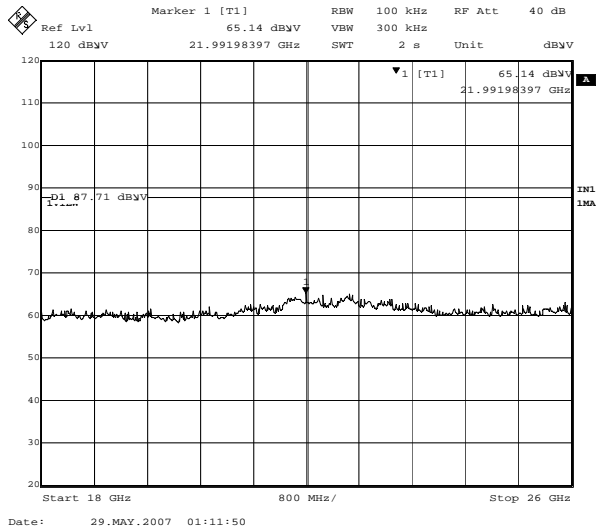

Out of Band Emission(Antenna Terminal Conducted): FCC 15.247(d)

COMPANY : RICOH COMPANY, LTD
EQUIPMENT : Option(s) for Radiocommunications
MODEL NUMBER : R-WL54CG
SERIAL NUMBER : 61290054
FCC ID : BBP-WLRW54G1
POWER : AC120V/60Hz

UL Japan, Inc. Yamakita No.2 Shielded Room
REPORT NO : 27IE0337-YK-D
REGULATION : Fcc Part15SubpartC 247(d)
DATE : 2007/05/29
TEMP./HUMI : 25deg.C./42%
Test Mode : Transmitting/Receiving
ENGINEER : Tatsuya Arai

[IEEE802.11b(11Mbps)]
Transmitting Ch6:2437MHz

1.

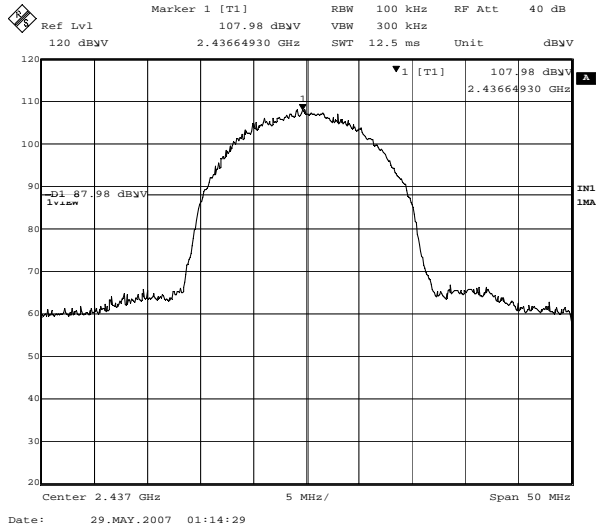

2.

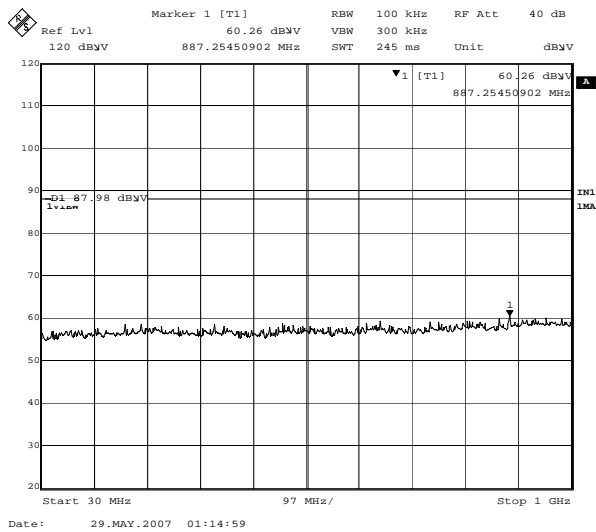

3.

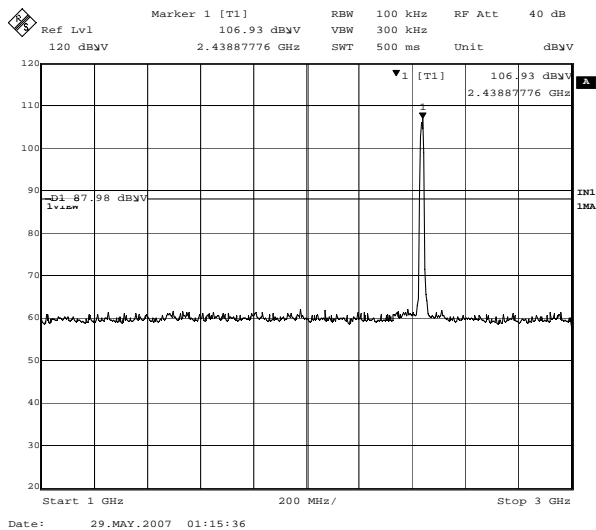

Out of Band Emission(Antenna Terminal Conducted): FCC 15.247(d)

COMPANY : RICOH COMPANY, LTD
EQUIPMENT : Option(s) for Radiocommunications
MODEL NUMBER: R-WL54CG
SERIAL NUMBER: 61290054
FCC ID : BBP-WLRW54G1
POWER : AC120V/60Hz

UL Japan, Inc. Yamakita No.2 Shielded Room
REPORT NO : 27IE0337-YK-D
REGULATION : Fcc Part15SubpartC 247(d)
DATE : 2007/05/29
TEMP./HUMI : 25deg.C./42%
Test Mode : Transmitting/Receiving
ENGINEER : Tatsuya Arai

[IEEE802.11b(11Mbps)]
Transmitting Ch6:2437MHz

4.

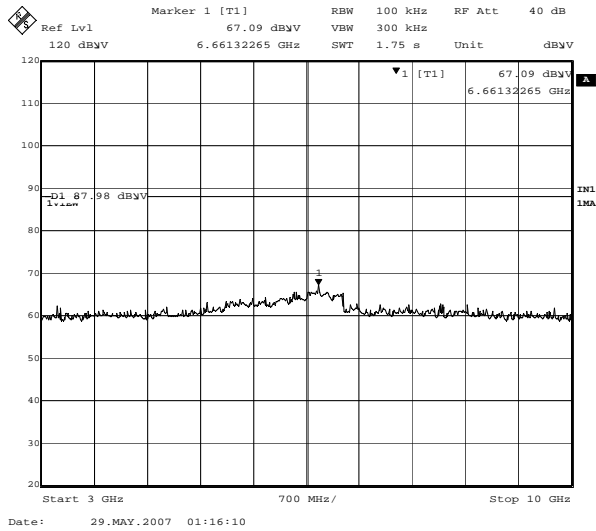

5.

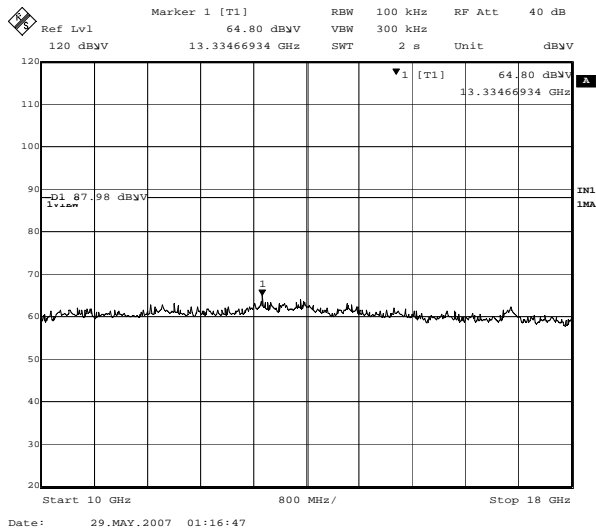

6.

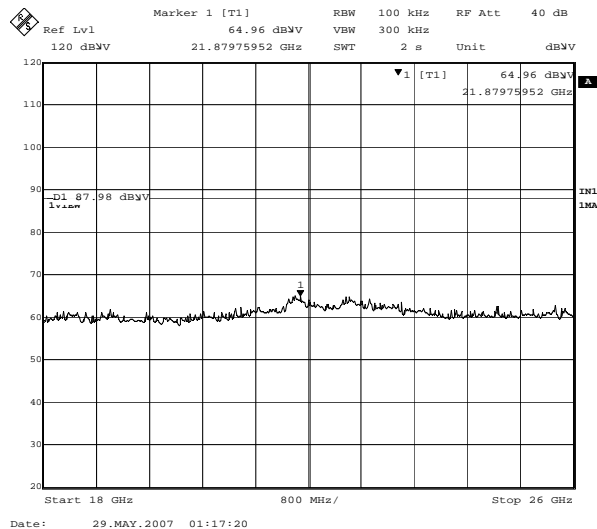

Out of Band Emission(Antenna Terminal Conducted): FCC 15.247(d)

COMPANY : RICOH COMPANY, LTD
EQUIPMENT : Option(s) for Radiocommunications
MODEL NUMBER: R-WL54CG
SERIAL NUMBER: 61290054
FCC ID : BBP-WLRW54G1
POWER : AC120V/60Hz

UL Japan, Inc. Yamakita No.2 Shielded Room
REPORT NO : 27IE0337-YK-D
REGULATION : Fcc Part15SubpartC 247(d)
DATE : 2007/05/29
TEMP./HUMI : 25deg.C./42%
Test Mode : Transmitting/Receiving
ENGINEER : Tatsuya Arai

[IEEE802.11b(11Mbps)]
Transmitting Ch11:2462MHz

1.

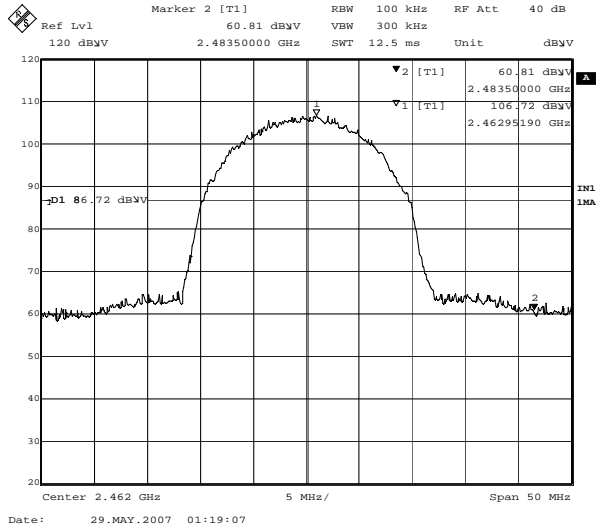

2.

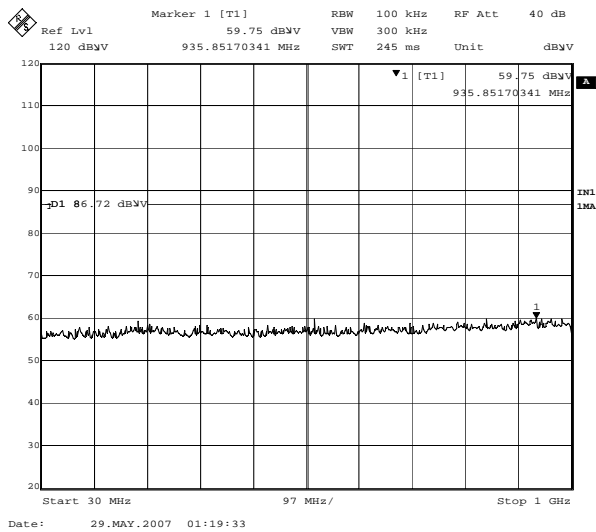

3.

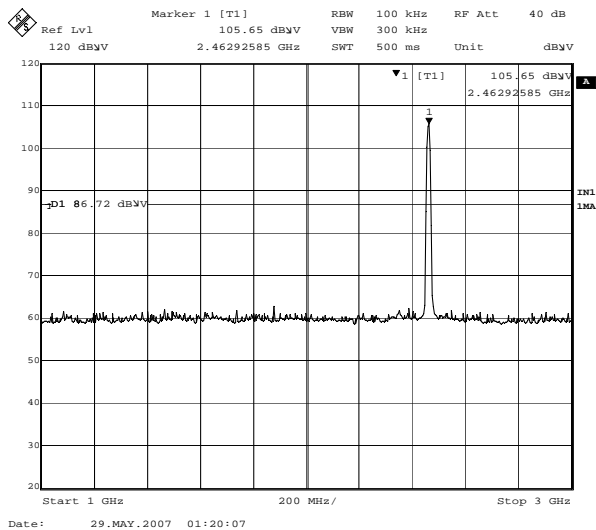

Out of Band Emission(Antenna Terminal Conducted): FCC 15.247(d)

COMPANY : RICOH COMPANY, LTD
EQUIPMENT : Option(s) for Radiocommunications
MODEL NUMBER: R-WL54CG
SERIAL NUMBER: 61290054
FCC ID : BBP-WLRW54G1
POWER : AC120V/60Hz

UL Japan, Inc. Yamakita No.2 Shielded Room
REPORT NO : 27IE0337-YK-D
REGULATION : Fcc Part15SubpartC 247(d)
DATE : 2007/05/29
TEMP./HUMI : 25deg.C./42%
Test Mode : Transmitting/Receiving
ENGINEER : Tatsuya Arai

[IEEE802.11b(11Mbps)]
Transmitting Ch11:2462MHz

4.

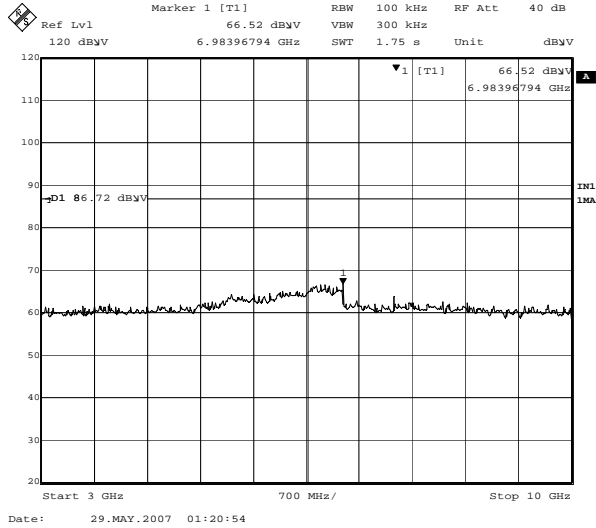

5.

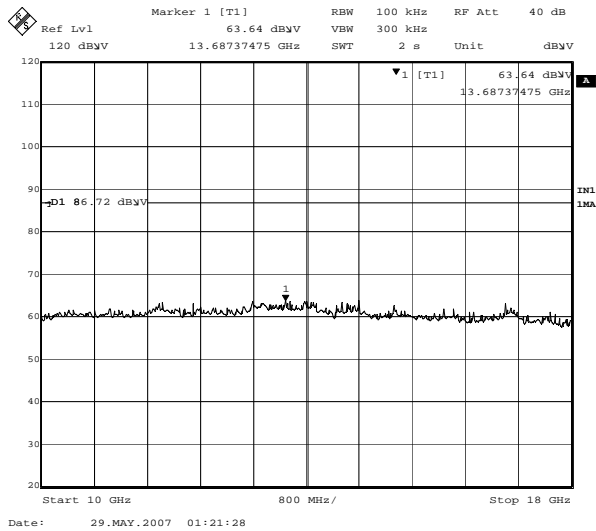

6.

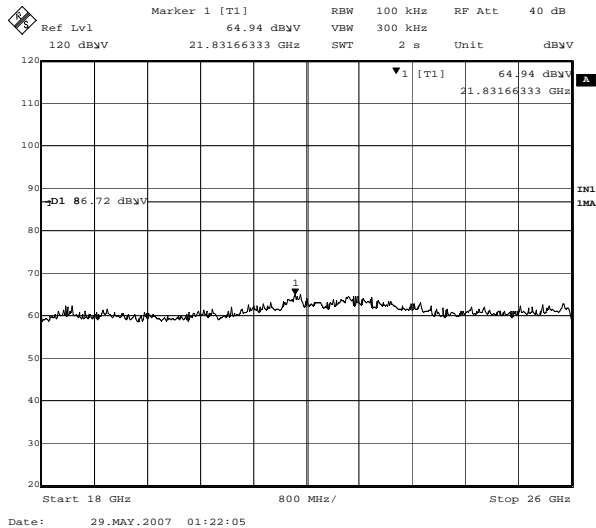

Out of Band Emission(Antenna Terminal Conducted): FCC 15.247(d)

COMPANY : RICOH COMPANY, LTD
EQUIPMENT : Option(s) for Radiocommunications
MODEL NUMBER: R-WL54CG
SERIAL NUMBER: 61290054
FCC ID : BBP-WLRW54G1
POWER : AC120V/60Hz

UL Japan, Inc. Yamakita No.2 Shielded Room
REPORT NO : 27IE0337-YK-D
REGULATION : Fcc Part15SubpartC 247(d)
DATE : 2007/05/29
TEMP./HUMI : 25deg.C./42%
Test Mode : Transmitting/Receiving
ENGINEER : Tatsuya Arai

[IEEE802.11g(54Mbps)]
Transmitting Ch1:2412MHz

1.

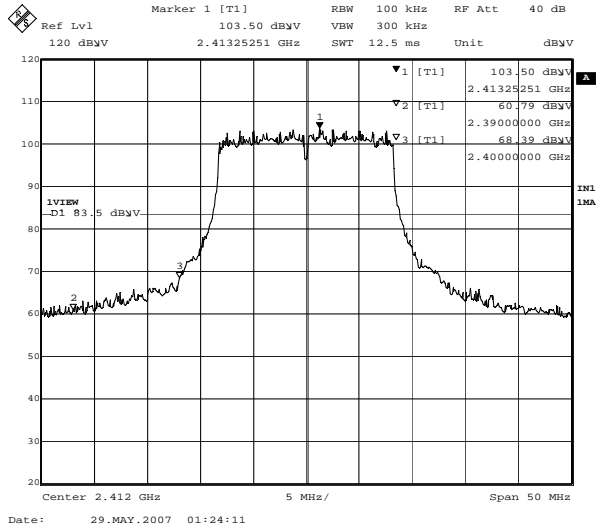

2.

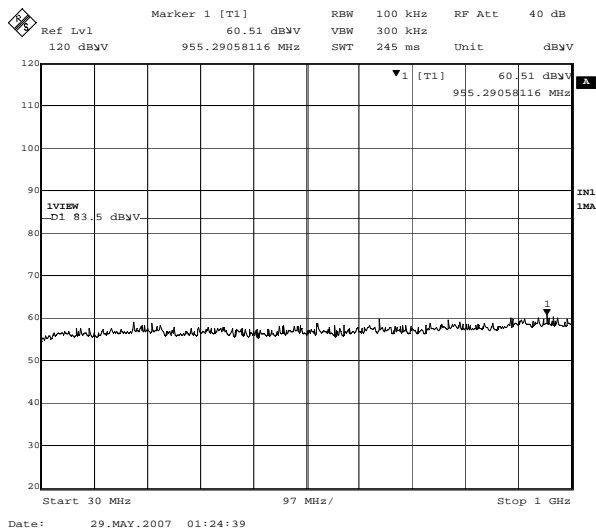

3.

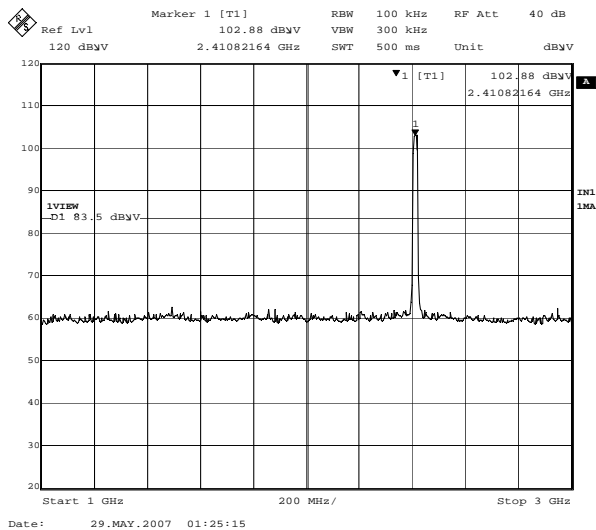

Out of Band Emission(Antenna Terminal Conducted): FCC 15.247(d)

COMPANY : RICOH COMPANY, LTD
EQUIPMENT : Option(s) for Radiocommunications
MODEL NUMBER: R-WL54CG
SERIAL NUMBER: 61290054
FCC ID : BBP-WLRW54G1
POWER : AC120V/60Hz

UL Japan, Inc. Yamakita No.2 Shielded Room
REPORT NO : 27IE0337-YK-D
REGULATION : Fcc Part15SubpartC 247(d)
DATE : 2007/05/29
TEMP./HUMI : 25deg.C./42%
Test Mode : Transmitting/Receiving
ENGINEER : Tatsuya Arai

[IEEE802.11g(54Mbps)]
Transmitting Ch1:2412MHz

4.

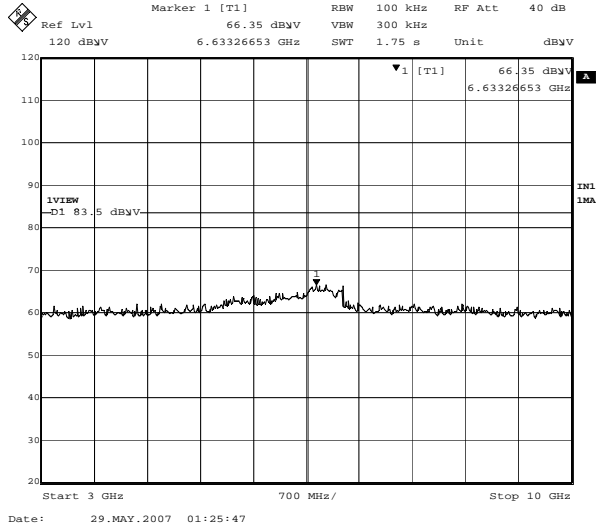

5.

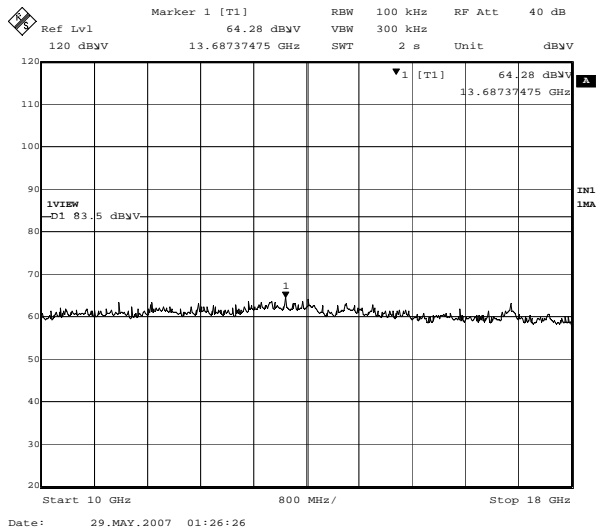

6.

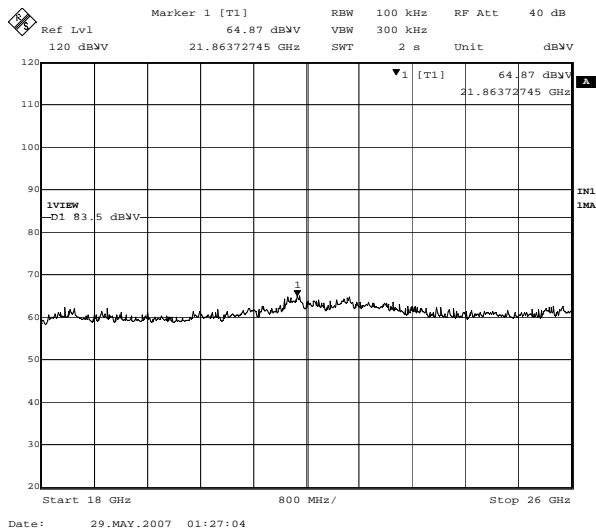

Out of Band Emission(Antenna Terminal Conducted): FCC 15.247(d)

COMPANY : RICOH COMPANY, LTD
EQUIPMENT : Option(s) for Radiocommunications
MODEL NUMBER: R-WL54CG
SERIAL NUMBER: 61290054
FCC ID : BBP-WLRW54G1
POWER : AC120V/60Hz

UL Japan, Inc. Yamakita No.2 Shielded Room
REPORT NO : 27IE0337-YK-D
REGULATION : Fcc Part15SubpartC 247(d)
DATE : 2007/05/29
TEMP./HUMI : 25deg.C./42%
Test Mode : Transmitting/Receiving
ENGINEER : Tatsuya Arai

[IEEE802.11g(54Mbps)]
Transmitting Ch6:2437MHz

4.

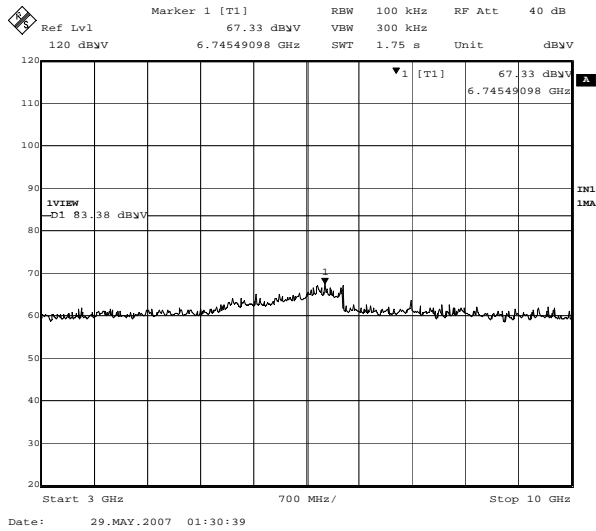

5.

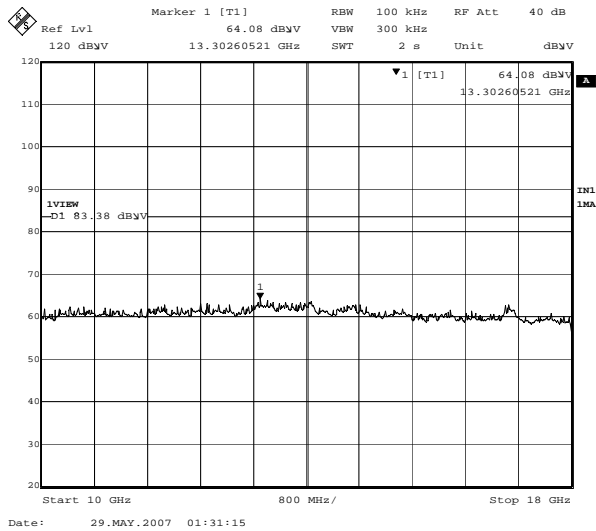

6.

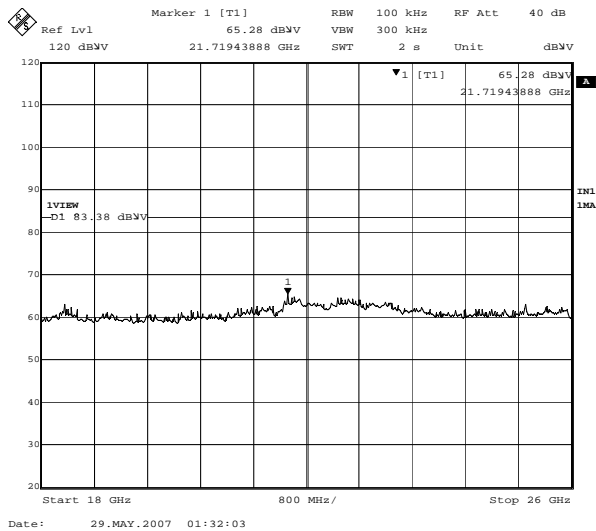

Out of Band Emission(Antenna Terminal Conducted): FCC 15.247(d)

COMPANY : RICOH COMPANY, LTD
EQUIPMENT : Option(s) for Radiocommunications
MODEL NUMBER: R-WL54CG
SERIAL NUMBER: 61290054
FCC ID : BBP-WLRW54G1
POWER : AC120V/60Hz

UL Japan, Inc. Yamakita No.2 Shielded Room
REPORT NO : 27IE0337-YK-D
REGULATION : Fcc Part15SubpartC 247(d)
DATE : 2007/05/29
TEMP./HUMI : 25deg.C./42%
Test Mode : Transmitting/Receiving
ENGINEER : Tatsuya Arai

[IEEE802.11g(54Mbps)]
Transmitting Ch11:2462MHz

1.

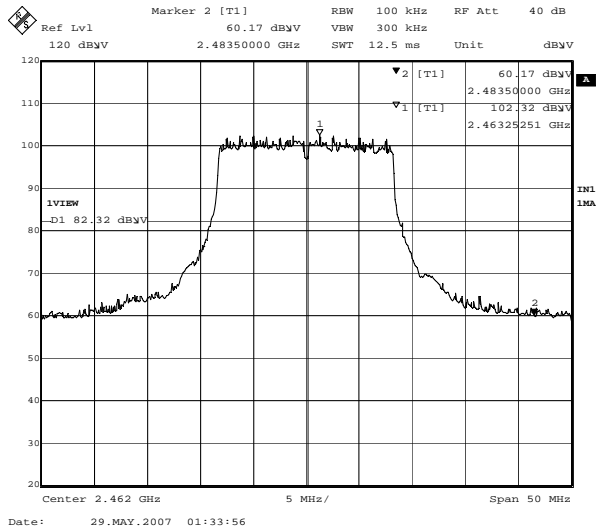

2.

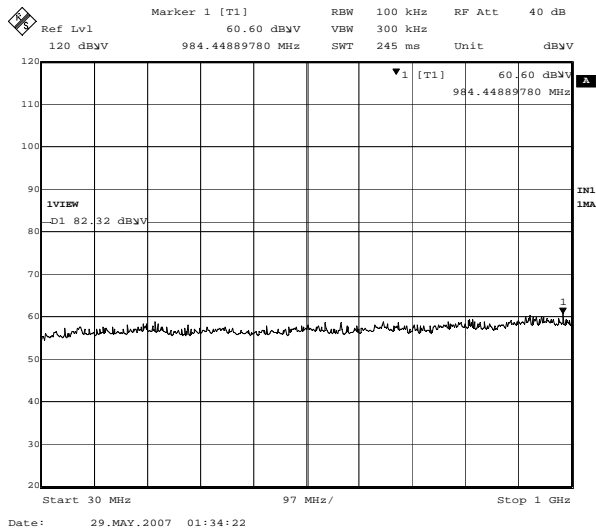

3.

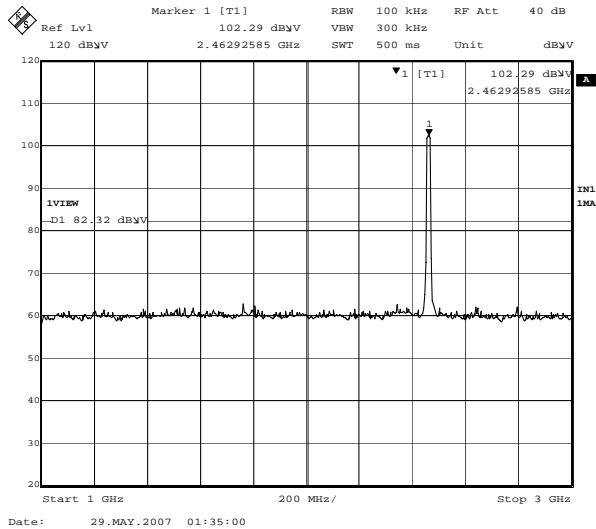

Out of Band Emission(Antenna Terminal Conducted): FCC 15.247(d)

COMPANY : RICOH COMPANY, LTD
EQUIPMENT : Option(s) for Radiocommunications
MODEL NUMBER: R-WL54CG
SERIAL NUMBER: 61290054
FCC ID : BBP-WLRW54G1
POWER : AC120V/60Hz

UL Japan, Inc. Yamakita No.2 Shielded Room
REPORT NO : 27IE0337-YK-D
REGULATION : Fcc Part15SubpartC 247(d)
DATE : 2007/05/29
TEMP./HUMI : 25deg.C./42%
Test Mode : Transmitting/Receiving
ENGINEER : Tatsuya Arai

[IEEE802.11g(54Mbps)]
Transmitting Ch11:2462MHz

4.

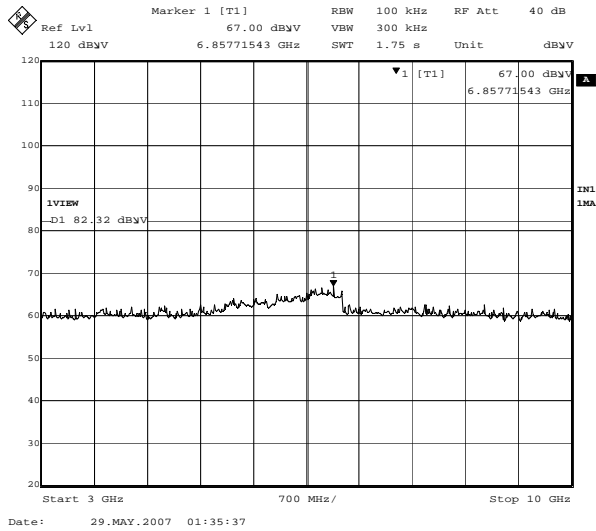

5.

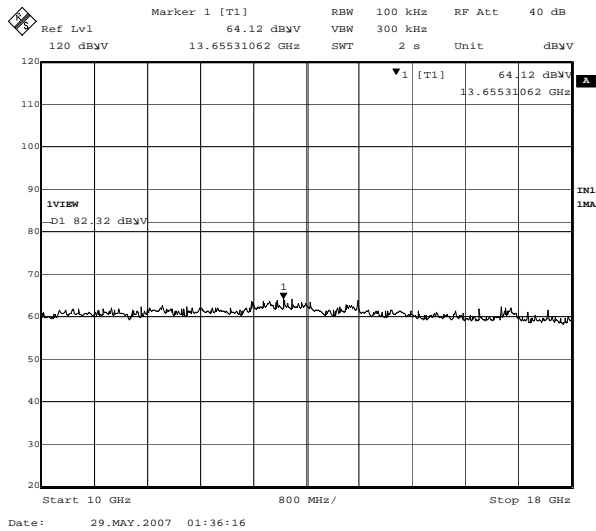

6.

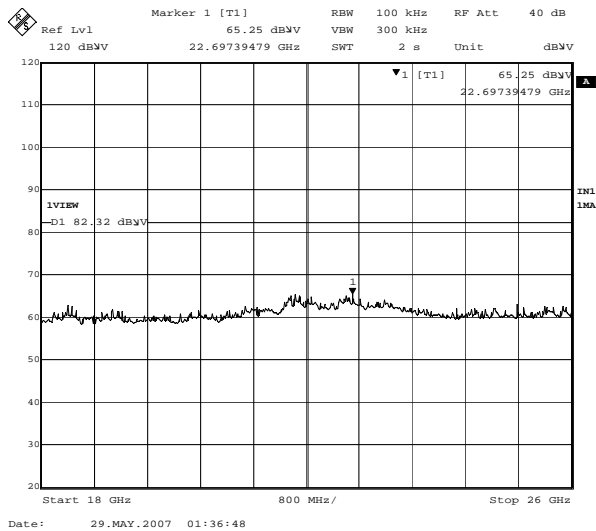

Out of Band Emission(Antenna Terminal Conducted): FCC 15.247(d)

COMPANY : RICOH COMPANY, LTD
EQUIPMENT : Option(s) for Radiocommunications
MODEL NUMBER : R-WL54CG
SERIAL NUMBER : 61290054
FCC ID : BBP-WLRW54G1
POWER : AC120V/60Hz

UL Japan, Inc. Yamakita No.2 Shielded Room
REPORT NO : 27IE0337-YK-D
REGULATION : Fcc Part15SubpartC 247(d)
DATE : 2007/05/29
TEMP./HUMI : 25deg.C./42%
Test Mode : Transmitting/Receiving
ENGINEER : Tatsuya Arai

[IEEE802.11g(54Mbps)]
Receiving (Ant1) Ch:2437MHz

1.

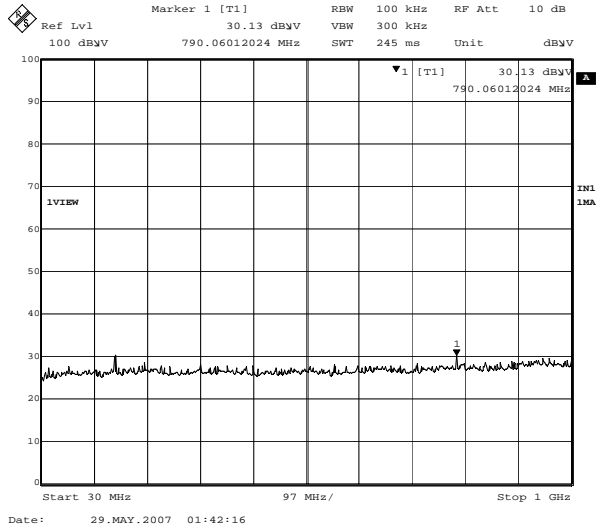

2.

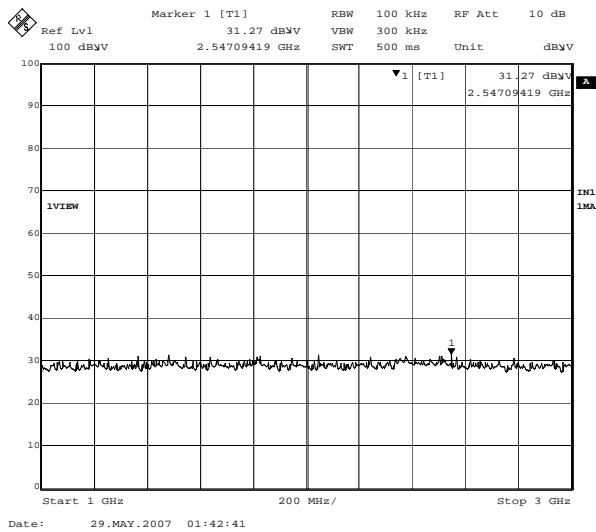

3.

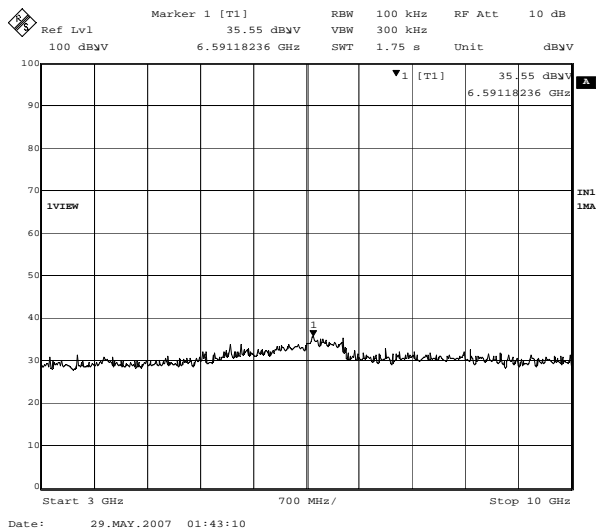

Out of Band Emission(Antenna Terminal Conducted): FCC 15.247(d)

COMPANY : RICOH COMPANY, LTD
EQUIPMENT : Option(s) for Radiocommunications
MODEL NUMBER : R-WL54CG
SERIAL NUMBER : 61290054
FCC ID : BBP-WLRW54G1
POWER : AC120V/60Hz

UL Japan, Inc. Yamakita No.2 Shielded Room
REPORT NO : 27IE0337-YK-D
REGULATION : Fcc Part15SubpartC 247(d)
DATE : 2007/05/29
TEMP./HUMI : 25deg.C./42%
Test Mode : Transmitting/Receiving
ENGINEER : Tatsuya Arai

[IEEE802.11g(54Mbps)]
Receiving (Ant2) Ch:2437MHz

1.

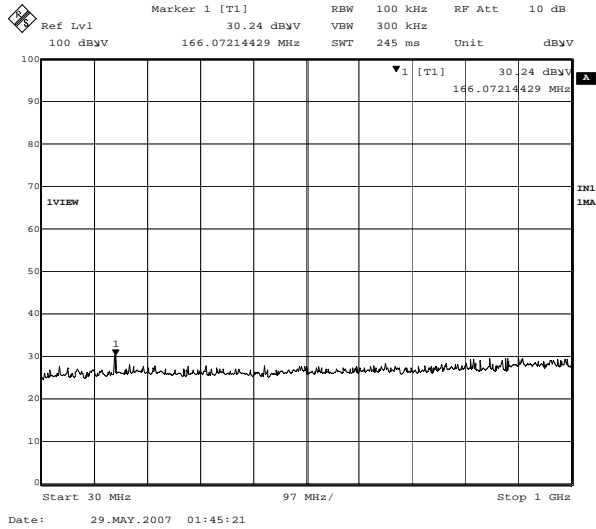

2.

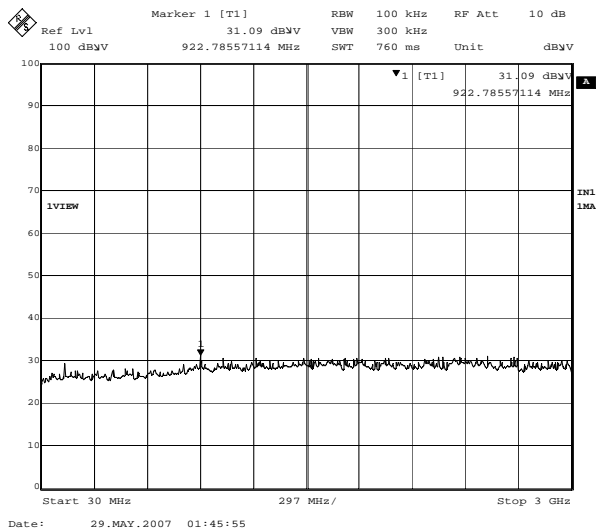

3.

