

*EMC Test Report
Application for Grant of Equipment Authorization
FCC Part 15 Subpart C*

Model: eQ102

FCC ID: BBP-WLNEWS102

APPLICANT: Ricoh Company, Ltd.
810 Shimoimaizumi, Ebina-Shi
Kanagawa-Ken, 243-0460 Japan

TEST SITE(S): Elliott Laboratories
41039 Boyce Road.
Fremont, CA. 94538-2435

IC SITE REGISTRATION #: 2845B-3; 2845B-4, 2845B-5, 2845B-7

REPORT DATE: September 23, 2011

FINAL TEST DATES: August 2, 9, 11 and 15, 2011

TOTAL NUMBER OF PAGES: 41

PROGRAM MGR /
TECHNICAL REVIEWER:

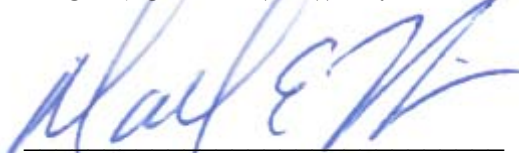

Mark E Hill
Staff Engineer

QUALITY ASSURANCE DELEGATE /
FINAL REPORT PREPARER:

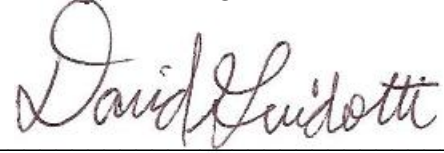

David Guidotti
Senior Technical Writer



Testing Cert #2016.01

Elliott Laboratories is accredited by the A2LA, certificate number 2016.01, to perform the test(s) listed in this report, except where noted otherwise. This report and the information contained herein represent the results of testing test articles identified and selected by the client performed to specifications and/or procedures selected by the client. National Technical Systems (NTS) makes no representations, expressed or implied, that such testing is adequate (or inadequate) to demonstrate efficiency, performance, reliability, or any other characteristic of the articles being tested, or similar products. This report should not be relied upon as an endorsement or certification by NTS of the equipment tested, nor does it represent any statement whatsoever as to its merchantability or fitness of the test article, or similar products, for a particular purpose. This report shall not be reproduced except in full.

REVISION HISTORY

Rev#	Date	Comments	Modified By
1	09-23-2011	First release	

TABLE OF CONTENTS

REVISION HISTORY	2
TABLE OF CONTENTS	3
SCOPE.....	4
OBJECTIVE	4
STATEMENT OF COMPLIANCE.....	5
DEVIATIONS FROM THE STANDARDS.....	5
TEST RESULTS SUMMARY	6
FREQUENCY HOPPING SPREAD SPECTRUM (2400 – 2483.5 MHZ, 75 CHANNELS OR MORE)	6
GENERAL REQUIREMENTS APPLICABLE TO ALL BANDS.....	6
MEASUREMENT UNCERTAINTIES.....	7
EQUIPMENT UNDER TEST (EUT) DETAILS.....	8
GENERAL.....	8
OTHER EUT DETAILS.....	8
ENCLOSURE.....	8
MODIFICATIONS.....	8
SUPPORT EQUIPMENT.....	8
EUT INTERFACE PORTS.....	9
EUT OPERATION.....	9
TEST SITE.....	10
GENERAL INFORMATION.....	10
CONDUCTED EMISSIONS CONSIDERATIONS.....	10
RADIATED EMISSIONS CONSIDERATIONS.....	10
MEASUREMENT INSTRUMENTATION	11
RECEIVER SYSTEM.....	11
INSTRUMENT CONTROL COMPUTER.....	11
LINE IMPEDANCE STABILIZATION NETWORK (LISN).....	11
FILTERS/ATTENUATORS.....	12
ANTENNAS.....	12
ANTENNA MAST AND EQUIPMENT TURNTABLE.....	12
INSTRUMENT CALIBRATION.....	12
TEST PROCEDURES	13
EUT AND CABLE PLACEMENT.....	13
CONDUCTED EMISSIONS.....	13
RADIATED EMISSIONS.....	13
RADIATED EMISSIONS.....	14
CONDUCTED EMISSIONS FROM ANTENNA PORT.....	16
BANDWIDTH MEASUREMENTS.....	16
SPECIFICATION LIMITS AND SAMPLE CALCULATIONS.....	17
CONDUCTED EMISSIONS SPECIFICATION LIMITS: FCC 15.207; FCC 15.107(A), RSS GEN.....	17
GENERAL TRANSMITTER RADIATED EMISSIONS SPECIFICATION LIMITS.....	18
OUTPUT POWER LIMITS – FHSS SYSTEMS.....	18
TRANSMIT MODE SPURIOUS RADIATED EMISSIONS LIMITS – FHSS AND DTS SYSTEMS.....	18
SAMPLE CALCULATIONS - CONDUCTED EMISSIONS.....	19
SAMPLE CALCULATIONS - RADIATED EMISSIONS.....	20
SAMPLE CALCULATIONS - FIELD STRENGTH TO EIRP CONVERSION.....	21
APPENDIX A TEST EQUIPMENT CALIBRATION DATA	22
APPENDIX B TEST DATA	24
END OF REPORT	41

SCOPE

An electromagnetic emissions test has been performed on the Ricoh Company, Ltd. model eQ102, pursuant to the following rules:

FCC Part 15 Subpart C

Conducted and radiated emissions data has been collected, reduced, and analyzed within this report in accordance with measurement guidelines set forth in the following reference standards and as outlined in Elliott Laboratories test procedures:

ANSI C63.4:2003

FHSS test procedure DA 00-0705A1, March 2000

The intentional radiator above has been tested in a simulated typical installation to demonstrate compliance with the relevant Industry Canada performance and procedural standards.

Final system data was gathered in a mode that tended to maximize emissions by varying orientation of EUT, orientation of power and I/O cabling, antenna search height, and antenna polarization.

Every practical effort was made to perform an impartial test using appropriate test equipment of known calibration. All pertinent factors have been applied to reach the determination of compliance.

OBJECTIVE

The primary objective of the manufacturer is compliance with the regulations outlined in the previous section.

Prior to marketing in the USA, all unlicensed transmitters and transceivers require certification. Receive-only devices operating between 30 MHz and 960 MHz are subject to either certification or a manufacturer's declaration of conformity, with all other receive-only devices exempt from the technical requirements.

Certification is a procedure where the manufacturer submits test data and technical information to a certification body and receives a certificate or grant of equipment authorization upon successful completion of the certification body's review of the submitted documents. Once the equipment authorization has been obtained, the label indicating compliance must be attached to all identical units, which are subsequently manufactured.

Maintenance of compliance is the responsibility of the manufacturer. Any modification of the product which may result in increased emissions should be checked to ensure compliance has been maintained (i.e., printed circuit board layout changes, different line filter, different power supply, harnessing or I/O cable changes, etc.).

STATEMENT OF COMPLIANCE

The tested sample of Ricoh Company, Ltd. model eQ102 complied with the requirements of the following regulations:

FCC Part 15 Subpart C

Maintenance of compliance is the responsibility of the manufacturer. Any modifications to the product should be assessed to determine their potential impact on the compliance status of the device with respect to the standards detailed in this test report.

The test results recorded herein are based on a single type test of Ricoh Company, Ltd. model eQ102 and therefore apply only to the tested sample. The sample was selected and prepared by Jay Moulton an agent of Ricoh Company, Ltd..

DEVIATIONS FROM THE STANDARDS

No deviations were made from the published requirements listed in the scope of this report.

TEST RESULTS SUMMARY**FREQUENCY HOPPING SPREAD SPECTRUM (2400 – 2483.5 MHz, 75 channels or more)**

FCC Rule Part	RSS Rule Part	Description	Measured Value / Comments	Limit / Requirement	Result
15.247 (a) (1)	RSS 210 A8.1 (1)	20dB Bandwidth	EDR: 1.43 MHz Basic: 1.10 MHz	Channel spacing > 2/3 of the 20dB bandwidth	Complies
		Channel Separation	1 MHz		Complies
15.247 (a) (1) (iii)	RSS 210 A8.1 (4)	Channel Dwell Time (<i>average time of occupancy</i>)	EUT complies with BlueTooth specification	<0.4 second within a period of 0.4 x number of channels	Complies
15.247 (a) (1) (iii)	RSS 210 A8.1 (4)	Number of Channels	79	15 or more	Complies
15.247 (a) (1)	RSS 210 A8.1 (1)	Channel Utilization	The system uses the BlueTooth algorithm and, therefore, meets all requirements for channel utilization.	All channels shall, on average, be used equally	Complies
15.247 (b) (3)	RSS 210 A8.4 (2)	Output Power (multipoint systems)	9.8 dBm (0.0095 Watts) EIRP = 0.016 W ^{Note 1}	0.125 W	Complies
15.247(c)	RSS 210 A8.5	Spurious Emissions – 30MHz – 25GHz	All spurious emissions < -20dBc	< -20dBc	Complies
15.247(c) / 15.209	RSS 210 A8.5 Table 2, 3	Radiated Spurious Emissions 30MHz – 25GHz	48.2dB μ V/m @ 2483.5MHz (-5.8dB)	15.207 in restricted bands, all others < -20dBc	Complies
15.247 (a) (1)	RSS 210 A8.1(2)	Receiver bandwidth	Refer to operational description	Shall match the channel bandwidth	Complies
Note 1: EIRP calculated using antenna gain of 2.2 dBi.					

GENERAL REQUIREMENTS APPLICABLE TO ALL BANDS

FCC Rule Part	RSS Rule part	Description	Measured Value / Comments	Limit / Requirement	Result (margin)
15.203	-	RF Connector	Antenna is integral and internal to the EUT	Unique or integral antenna required	Complies
15.207	RSS GEN Table 2	AC Conducted Emissions	47.5dB μ V @ 2.451MHz (-8.5dB)	Refer to page 17	Complies
15.109	RSS GEN 7.2.3 Table 1	Receiver spurious emissions	N/A – Tunes above 960 MHz	Refer to Standard	N/A
15.247 (b) (5) 15.407 (f)	RSS 102	RF Exposure Requirements	Refer to SAR report and RSS 102 declaration	Refer to OET 65, FCC Part 1 and RSS 102	Complies

MEASUREMENT UNCERTAINTIES

ISO/IEC 17025 requires that an estimate of the measurement uncertainties associated with the emissions test results be included in the report. The measurement uncertainties given below are based on a 95% confidence level and were calculated in accordance with UKAS document LAB 34.

Measurement Type	Measurement Unit	Frequency Range	Expanded Uncertainty
RF power, conducted (power meter)	dBm	25 to 7000 MHz	± 0.52 dB
RF power, conducted (Spectrum analyzer)	dBm	25 to 7000 MHz	± 0.7 dB
Conducted emission of transmitter	dBm	25 to 26500 MHz	± 0.7 dB
Conducted emission of receiver	dBm	25 to 26500 MHz	± 0.7 dB
Radiated emission (substitution method)	dBm	25 to 26500 MHz	± 2.5 dB
Radiated emission (field strength)	dB μ V/m	25 to 1000 MHz	± 3.6 dB
		1000 to 40000 MHz	± 6.0 dB
Conducted Emissions (AC Power)	dB μ V	0.15 to 30 MHz	± 2.4 dB

EQUIPMENT UNDER TEST (EUT) DETAILS**GENERAL**

The Ricoh Company, Ltd. model eQ102 is an eWriter/tablet computer.

The sample was received on July 25, 2011 and tested on August 2, 9, 11 and 15, 2011. The EUT consisted of the following component(s):

Company	Model	Description	Serial Number	FCC ID
Ricoh	eQuill	e-book reader/tablet computer	-	BBP-WLNEWS102
V-Infinity	3A-061WU05B	AC/DC Adapter	-	N/A

OTHER EUT DETAILS

The Bluetooth/WiFi radio uses a printed inverted-F pcb trace antenna, 2.2dBi max gain.

ENCLOSURE

The EUT enclosure measures approximately 19 by 24.5 by 0.5 centimeters. It is primarily constructed of uncoated plastic.

MODIFICATIONS

No modifications were made to the EUT during the time the product was at Elliott.

SUPPORT EQUIPMENT

The following equipment was used as support equipment for testing:

Company	Model	Description	Serial Number	FCC ID
Dell	D620	Laptop Computer	14030653249	DoC
RII EPT	-	USB Extender Board	-	-

EUT INTERFACE PORTS

The I/O cabling configuration during testing was as follows:

Port	Connected To	Description	Cable(s)	
			Shielded or Unshielded	Length(m)
Laptop USB	Extender	Multiconductor	Shielded	1.0
Extender	EUT	Ribbon Cable	Unshielded	0.2
USB	AC/DC Adapter	Multiconductor	Shielded	1.5

EUT OPERATION

During testing, the EUT was configured for continuous transmission on the noted channel, using the modulation noted.

TEST SITE**GENERAL INFORMATION**

Final test measurements were taken at the test sites listed below. Pursuant to section 2.948 of the FCC's Rules and section 3.3 of RSP-100, construction, calibration, and equipment data has been filed with the Commission and with industry Canada.

Site	Registration Numbers		Location
	FCC	Canada	
Chamber 3	769238	2845B-3	41039 Boyce Road Fremont, CA 94538-2435
Chamber 4	211948	2845B-4	
Chamber 5	211948	2845B-5	
Chamber 7	A2LA accreditation	2845B-7	

ANSI C63.4:2003 recommends that ambient noise at the test site be at least 6 dB below the allowable limits. Ambient levels are below this requirement. The test site(s) contain separate areas for radiated and conducted emissions testing. Considerable engineering effort has been expended to ensure that the facilities conform to all pertinent requirements of ANSI C63.4:2003.

CONDUCTED EMISSIONS CONSIDERATIONS

Conducted emissions testing is performed in conformance with ANSI C63.4:2003. Measurements are made with the EUT connected to the public power network through a nominal, standardized RF impedance, which is provided by a line impedance stabilization network, known as a LISN. A LISN is inserted in series with each current-carrying conductor in the EUT power cord.

RADIATED EMISSIONS CONSIDERATIONS

The FCC has determined that radiation measurements made in a shielded enclosure are not suitable for determining levels of radiated emissions. Radiated measurements are performed in an open field environment or in a semi-anechoic chamber. The test sites are maintained free of conductive objects within the CISPR defined elliptical area incorporated in ANSI C63.4:2003 guidelines and meet the Normalized Site Attenuation (NSA) requirements of ANSI C63.4:2003.

MEASUREMENT INSTRUMENTATION

RECEIVER SYSTEM

An EMI receiver as specified in CISPR 16-1-1 is used for emissions measurements. The receivers used can measure over the frequency range of 9 kHz up to 2000 MHz. These receivers allow both ease of measurement and high accuracy to be achieved. The receivers have Peak, Average, and CISPR (Quasi-peak) detectors built into their design so no external adapters are necessary. The receiver automatically sets the required bandwidth for the CISPR detector used during measurements. If the repetition frequency of the signal being measured is below 20Hz, peak measurements are made in lieu of Quasi-Peak measurements.

For measurements above the frequency range of the receivers, a spectrum analyzer is utilized because it provides visibility of the entire spectrum along with the precision and versatility required to support engineering analysis. Average measurements above 1000MHz are performed on the spectrum analyzer using the linear-average method with a resolution bandwidth of 1 MHz and a video bandwidth of 10 Hz, unless the signal is pulsed in which case the average (or video) bandwidth of the measuring instrument is reduced to onset of pulse desensitization and then increased.

INSTRUMENT CONTROL COMPUTER

The receivers utilize either a Rohde & Schwarz EZM Spectrum Monitor/Controller or contain an internal Spectrum Monitor/Controller to view and convert the receiver measurements to the field strength at an antenna or voltage developed at the LISN measurement port, which is then compared directly with the appropriate specification limit. This provides faster, more accurate readings by performing the conversions described under Sample Calculations within the Test Procedures section of this report. Results are printed in a graphic and/or tabular format, as appropriate. A personal computer is used to record all measurements made with the receivers.

The Spectrum Monitor provides a visual display of the signal being measured. In addition, the controller or a personal computer run automated data collection programs which control the receivers. This provides added accuracy since all site correction factors, such as cable loss and antenna factors are added automatically.

LINE IMPEDANCE STABILIZATION NETWORK (LISN)

Line conducted measurements utilize a fifty microhenry Line Impedance Stabilization Network as the monitoring point. The LISN used also contains a 250 uH CISPR adapter. This network provides for calibrated radio frequency noise measurements by the design of the internal low pass and high pass filters on the EUT and measurement ports, respectively.

FILTERS/ATTENUATORS

External filters and precision attenuators are often connected between the receiving antenna or LISN and the receiver. This eliminates saturation effects and non-linear operation due to high amplitude transient events.

ANTENNAS

A loop antenna is used below 30 MHz. For the measurement range 30 MHz to 1000 MHz either a combination of a biconical antenna and a log periodic or a bi-log antenna is used. Above 1000 MHz, horn antennas are used. The antenna calibration factors to convert the received voltage to an electric field strength are included with appropriate cable loss and amplifier gain factors to determine an overall site factor, which is then programmed into the test receivers or incorporated into the test software.

ANTENNA MAST AND EQUIPMENT TURNTABLE

The antennas used to measure the radiated electric field strength are mounted on a non-conductive antenna mast equipped with a motor-drive to vary the antenna height. Measurements below 30 MHz are made with the loop antenna at a fixed height of 1m above the ground plane.

ANSI C63.4:2003 specifies that the test height above ground for table mounted devices shall be 80 centimeters. Floor mounted equipment shall be placed on the ground plane if the device is normally used on a conductive floor or separated from the ground plane by insulating material from 3 to 12 mm if the device is normally used on a non-conductive floor. During radiated measurements, the EUT is positioned on a motorized turntable in conformance with this requirement.

INSTRUMENT CALIBRATION

All test equipment is regularly checked to ensure that performance is maintained in accordance with the manufacturer's specifications. All antennas are calibrated at regular intervals with respect to tuned half-wave dipoles. An exhibit of this report contains the list of test equipment used and calibration information.

TEST PROCEDURES

EUT AND CABLE PLACEMENT

The regulations require that interconnecting cables be connected to the available ports of the unit and that the placement of the unit and the attached cables simulate the worst case orientation that can be expected from a typical installation, so far as practicable. To this end, the position of the unit and associated cabling is varied within the guidelines of ANSI C63.4:2003, and the worst-case orientation is used for final measurements.

CONDUCTED EMISSIONS

Conducted emissions are measured at the plug end of the power cord supplied with the EUT. Excess power cord length is wrapped in a bundle between 30 and 40 centimeters in length near the center of the cord. Preliminary measurements are made to determine the highest amplitude emission relative to the specification limit for all the modes of operation. Placement of system components and varying of cable positions are performed in each mode. A final peak mode scan is then performed in the position and mode for which the highest emission was noted on all current carrying conductors of the power cord.

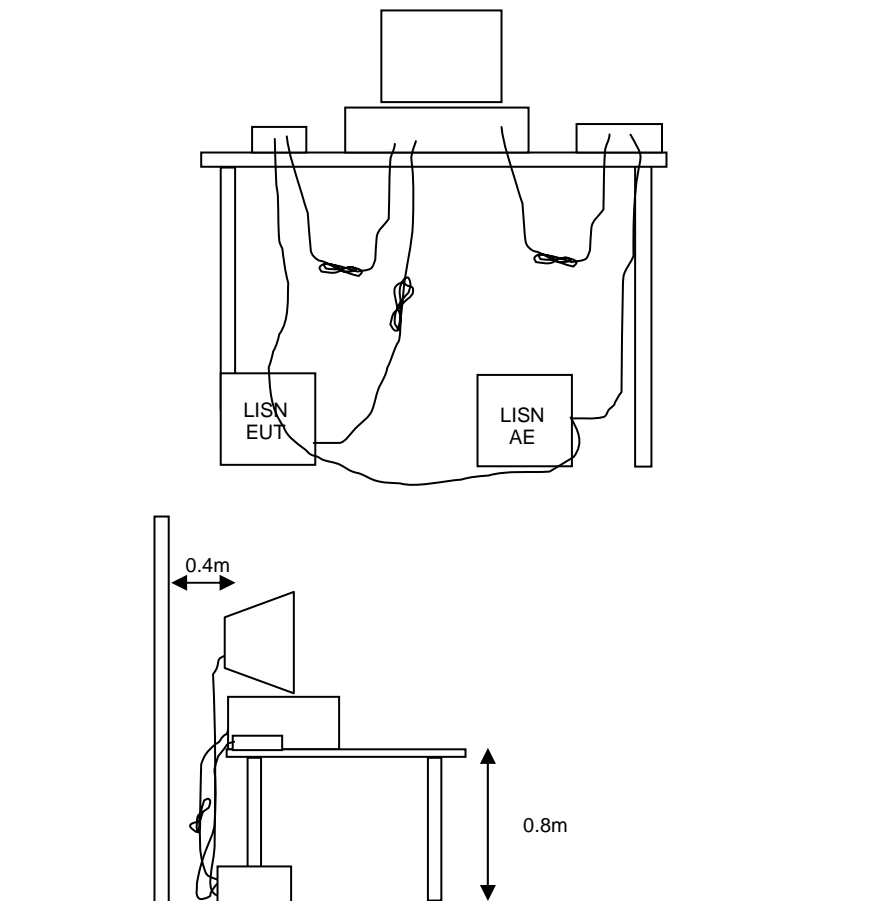

Figure 1 Typical Conducted Emissions Test Configuration

RADIATED EMISSIONS

A preliminary scan of the radiated emissions is performed in which all significant EUT frequencies are identified with the system in a nominal configuration. At least two scans are performed, one scan for each antenna polarization (horizontal and vertical; loop parallel and perpendicular to the EUT). During the preliminary scans, the EUT is rotated through 360°, the antenna height is varied (for measurements above 30 MHz) and cable positions are varied to determine the highest emission relative to the limit. Preliminary scans may be performed in a fully anechoic chamber for the purposes of identifying the frequencies of the highest emissions from the EUT.

A speaker is provided in the receiver to aid in discriminating between EUT and ambient emissions. Other methods used during the preliminary scan for EUT emissions involve scanning with near field magnetic loops, monitoring I/O cables with RF current clamps, and cycling power to the EUT.

Final maximization is a phase in which the highest amplitude emissions identified in the spectral search are viewed while the EUT azimuth angle is varied from 0 to 360 degrees relative to the receiving antenna. The azimuth, which results in the highest emission is then maintained while varying the antenna height from one to four meters (for measurements above 30 MHz, measurements below 30 MHz are made with the loop antenna at a fixed height of 1m). The result is the identification of the highest amplitude for each of the highest peaks. Each recorded level is corrected in the receiver using appropriate factors for cables, connectors, antennas, and preamplifier gain.

When testing above 18 GHz, the receive antenna is located at 1 meter from the EUT and the antenna height is restricted to a maximum of 2.5 meters.

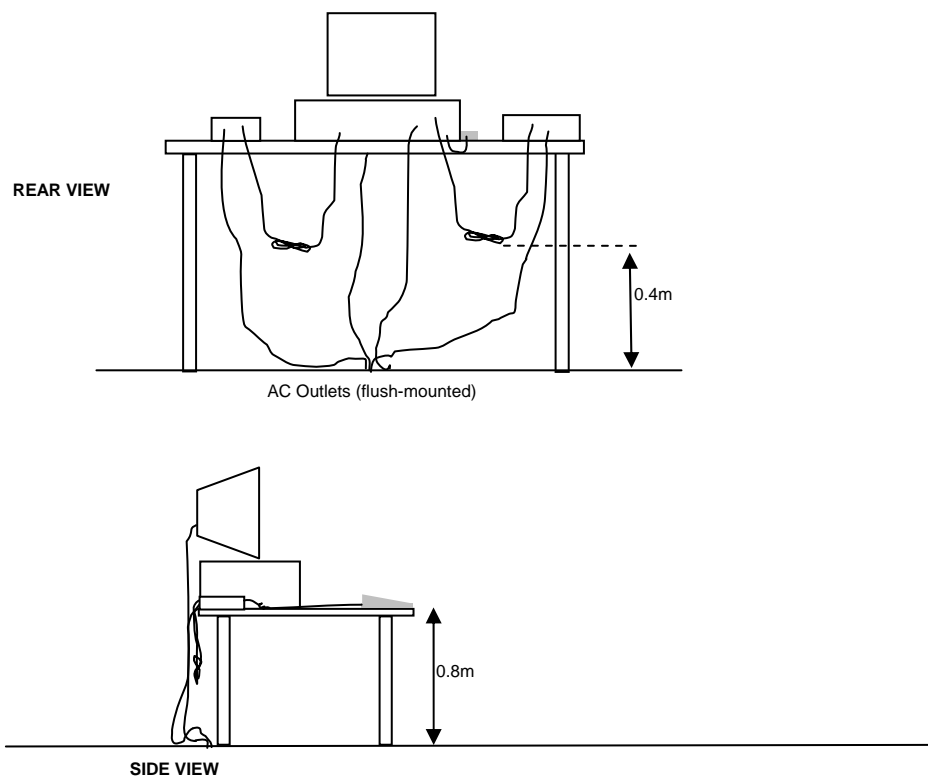

Typical Test Configuration for Radiated Field Strength Measurements

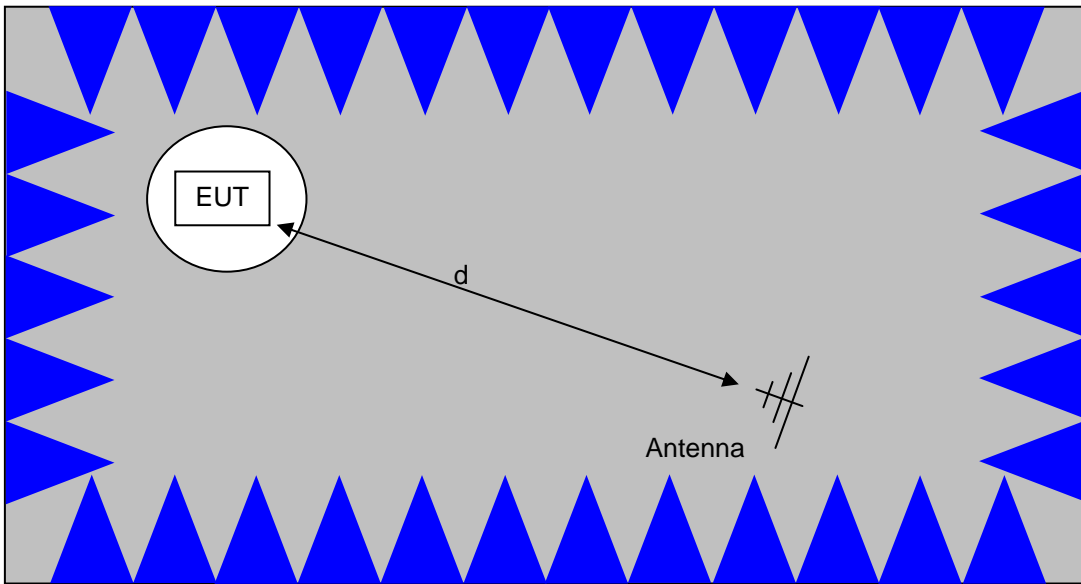

The anechoic materials on the walls and ceiling ensure compliance with the normalized site attenuation requirements of CISPR 16 / CISPR 22 / ANSI C63.4 for an alternate test site at the measurement distances used.

Floor-standing equipment is placed on the floor with insulating supports between the unit and the ground plane.

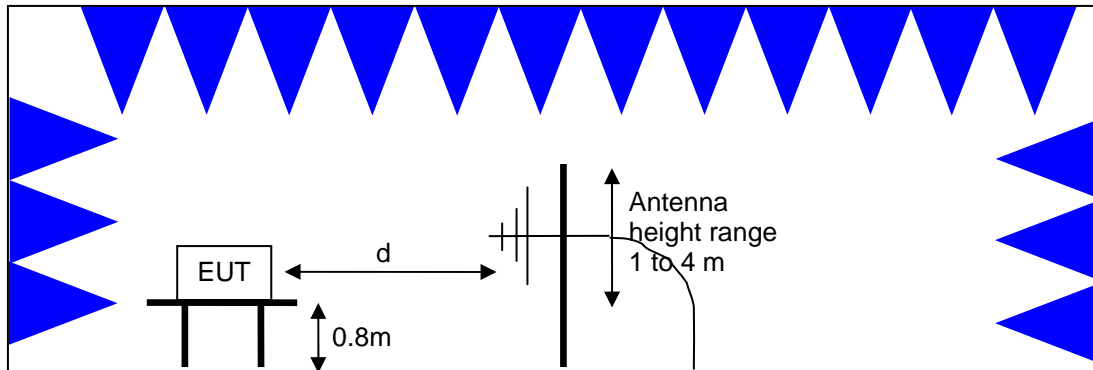

Test Configuration for Radiated Field Strength Measurements
Semi-Anechoic Chamber, Plan and Side Views

CONDUCTED EMISSIONS FROM ANTENNA PORT

Direct measurements of power, bandwidth and power spectral density are performed, where possible, with the antenna port of the EUT connected to either the power meter or spectrum analyzer via a suitable attenuator and/or filter. These are used to ensure that the front end of the measurement instrument is not overloaded by the fundamental transmission.

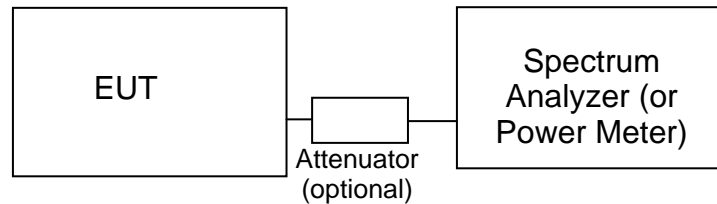
**Test Configuration for Antenna Port Measurements**

Measurement bandwidths (video and resolution) are set in accordance with the relevant standards and Elliott's test procedures for the type of radio being tested. When power measurements are made using a resolution bandwidth less than the signal bandwidth the power is calculated by summing the power across the signal bandwidth using either the analyzer channel power function or by capturing the trace data and calculating the power using software. In both cases the summed power is corrected to account for the equivalent noise bandwidth (ENBW) of the resolution bandwidth used.

If power averaging is used (typically for certain digital modulation techniques), the EUT is configured to transmit continuously. Power averaging is performed using either the built-in function of the analyzer or, if the analyzer does not feature power averaging, using external software. In both cases the average power is calculated over a number of sweeps (typically 100). When the EUT cannot be configured to continuously transmit then either the analyzer is configured to perform a gated sweep to ensure that the power is averaged over periods that the device is transmitting or power averaging is disabled and a max-hold feature is used.

If a power meter is used to make output power measurements the sensor head type (peak or average) is stated in the test data table.

BANDWIDTH MEASUREMENTS

The 6dB, 20dB and/or 26dB signal bandwidth is measured in using the bandwidths recommended by ANSI C63.4. When required, the 99% bandwidth is measured using the methods detailed in RSS GEN.

SPECIFICATION LIMITS AND SAMPLE CALCULATIONS

The limits for conducted emissions are given in units of microvolts, and the limits for radiated emissions are given in units of microvolts per meter at a specified test distance. Data is measured in the logarithmic form of decibels relative to one microvolt, or dB microvolts (dBuV). For radiated emissions, the measured data is converted to the field strength at the antenna in dB microvolts per meter (dBuV/m). The results are then converted to the linear forms of uV and uV/m for comparison to published specifications.

For reference, converting the specification limits from linear to decibel form is accomplished by taking the base ten logarithm, then multiplying by 20. These limits in both linear and logarithmic form are as follows:

CONDUCTED EMISSIONS SPECIFICATION LIMITS: FCC 15.207; FCC 15.107(a), RSS GEN

The table below shows the limits for the emissions on the AC power line from an intentional radiator and a receiver.

Frequency (MHz)	Average Limit (dBuV)	Quasi Peak Limit (dBuV)
0.150 to 0.500	Linear decrease on logarithmic frequency axis between 56.0 and 46.0	Linear decrease on logarithmic frequency axis between 66.0 and 56.0
0.500 to 5.000	46.0	56.0
5.000 to 30.000	50.0	60.0

GENERAL TRANSMITTER RADIATED EMISSIONS SPECIFICATION LIMITS

The table below shows the limits for the spurious emissions from transmitters that fall in restricted bands¹ (with the exception of transmitters operating under FCC Part 15 Subpart D and RSS 210 Annex 9), the limits for all emissions from a low power device operating under the general rules of RSS 310 (tables 3 and 4), RSS 210 (table 2) and FCC Part 15 Subpart C section 15.209.

Frequency Range (MHz)	Limit (uV/m)	Limit (dBuV/m @ 3m)
0.009-0.490	2400/F _{KHz} @ 300m	67.6-20*log ₁₀ (F _{KHz}) @ 300m
0.490-1.705	24000/F _{KHz} @ 30m	87.6-20*log ₁₀ (F _{KHz}) @ 30m
1.705 to 30	30 @ 30m	29.5 @ 30m
30 to 88	100 @ 3m	40 @ 3m
88 to 216	150 @ 3m	43.5 @ 3m
216 to 960	200 @ 3m	46.0 @ 3m
Above 960	500 @ 3m	54.0 @ 3m

OUTPUT POWER LIMITS – FHSS SYSTEMS

The table below shows the limits for output power based on the number of channels available for the hopping system.

Operating Frequency (MHz)	Number of Channels	Output Power
902 – 928	≥ 50	1 Watt (30 dBm)
902 – 928	25 to 49	0.25 Watts (24 dBm)
2400 – 2483.5	≥ 75	1 Watt (30 dBm)
2400 – 2483.5	< 75	0.125 Watts (21 dBm)
5725 – 5850	75	1 Watt (30 dBm)

The maximum permitted output power is reduced by 1dB for every dB the antenna gain exceeds 6dBi. Fixed point-to-point applications using the 5725 – 5850 MHz band are not subject to this restriction.

TRANSMIT MODE SPURIOUS RADIATED EMISSIONS LIMITS – FHSS and DTS SYSTEMS

The limits for unwanted (spurious) emissions from the transmitter falling in the restricted bands are those specified in the general limits sections of FCC Part 15 and RSS 210. All other unwanted (spurious) emissions shall be at least 20dB below the level of the highest in-band signal level (30dB if the power is measured using the sample detector/power averaging method).

¹ The restricted bands are detailed in FCC 15.203, RSS 210 Table 1 and RSS 310 Table 2

SAMPLE CALCULATIONS - CONDUCTED EMISSIONS

Receiver readings are compared directly to the conducted emissions specification limit (decibel form) as follows:

$$R_r - S = M$$

where:

R_r = Receiver Reading in dBuV

S = Specification Limit in dBuV

M = Margin to Specification in +/- dB

SAMPLE CALCULATIONS - RADIATED EMISSIONS

Receiver readings are compared directly to the specification limit (decibel form). The receiver internally corrects for cable loss, preamplifier gain, and antenna factor. The calculations are in the reverse direction of the actual signal flow, thus cable loss is added and the amplifier gain is subtracted. The Antenna Factor converts the voltage at the antenna coaxial connector to the field strength at the antenna elements.

A distance factor, when used for electric field measurements above 30MHz, is calculated by using the following formula:

$$F_d = 20 * \text{LOG}_{10} (D_m/D_s)$$

where:

$$F_d = \text{Distance Factor in dB}$$

$$D_m = \text{Measurement Distance in meters}$$

$$D_s = \text{Specification Distance in meters}$$

For electric field measurements below 30MHz the extrapolation factor is either determined by making measurements at multiple distances or a theoretical value is calculated using the formula:

$$F_d = 40 * \text{LOG}_{10} (D_m/D_s)$$

Measurement Distance is the distance at which the measurements were taken and Specification Distance is the distance at which the specification limits are based. The antenna factor converts the voltage at the antenna coaxial connector to the field strength at the antenna elements.

The margin of a given emission peak relative to the limit is calculated as follows:

$$R_c = R_r + F_d$$

and

$$M = R_c - L_s$$

where:

$$R_r = \text{Receiver Reading in dBuV/m}$$

$$F_d = \text{Distance Factor in dB}$$

$$R_c = \text{Corrected Reading in dBuV/m}$$

$$L_s = \text{Specification Limit in dBuV/m}$$

$$M = \text{Margin in dB Relative to Spec}$$

SAMPLE CALCULATIONS - FIELD STRENGTH TO EIRP CONVERSION

Where the radiated electric field strength is expressed in terms of the equivalent isotropic radiated power (eirp), or where a field strength measurement of output power is made in lieu of a direct measurement, the following formula is used to convert between eirp and field strength at a distance of d (meters) from the equipment under test:

$$E = \frac{1000000 \sqrt{30 P}}{d} \quad \text{microvolts per meter}$$

where P is the eirp (Watts)

For a measurement at 3m the conversion from a logarithmic value for field strength (dBuV/m) to an eirp power (dBm) is -95.3dB.

Appendix A Test Equipment Calibration Data**Radiated Emissions, 1000 - 26,000 MHz, 25-Jul-11**

<u>Manufacturer</u>	<u>Description</u>	<u>Model</u>	<u>Asset #</u>	<u>Cal Due</u>
Hewlett Packard	Microwave Preamplifier, 1-26.5GHz	8449B	263	12/8/2011
Hewlett Packard	Head (Inc flex cable, 1143, 2198) Red	84125C	1145	2/17/2012
Hewlett Packard	SpecAn 30 Hz -40 GHz, SV (SA40) Red	8564E (84125C)	1148	8/12/2011
Hewlett Packard	High Pass filter, 3.5 GHz	P/N 84300-80038	1157	9/3/2011
EMCO	Antenna, Horn, 1-18 GHz (SA40-Blu)	3115	1386	9/21/2012
A.H. Systems	Purple System Horn, 18-40GHz	SAS-574, p/n: 2581	2160	2/9/2012
Micro-Tronics	Band Reject Filter, 2400-2500 MHz	BRM50702-02	2249	10/11/2011

Radiated Emissions, 30 - 6,000 MHz, 26-Jul-11

<u>Manufacturer</u>	<u>Description</u>	<u>Model</u>	<u>Asset #</u>	<u>Cal Due</u>
EMCO	Antenna, Horn, 1-18GHz	3115	868	6/8/2012
Rohde & Schwarz	EMI Test Receiver, 20 Hz-7 GHz	ESIB7	1538	11/2/2011
Hewlett Packard	Preamplifier, 100 kHz - 1.3 GHz	8447D OPT 010	1826	5/17/2012
Hewlett Packard	9kHz-40GHz Analyzer	8564E	2190	8/21/2011
Sunol Sciences	Biconilog, 30-3000 MHz	JB3	2197	12/29/2011
Hewlett Packard	Microwave Preamplifier, 1-26.5GHz	8449B	2199	2/23/2012

Conducted Emissions - AC Power Ports, 27-Jul-11

<u>Manufacturer</u>	<u>Description</u>	<u>Model</u>	<u>Asset #</u>	<u>Cal Due</u>
EMCO	LISN, 10 kHz-100 MHz	3825/2	1293	3/1/2012
Hewlett Packard	EMC Spectrum Analyzer, 9 KHz - 22 GHz	8593EM	1319	11/22/2011
Rohde & Schwarz	Test Receiver, 0.009-2750 MHz	ESN	1332	1/17/2012
Rohde & Schwarz	Pulse Limiter	ESH3 Z2	1594	5/17/2012

Radiated Emissions, 1000 - 18,000 MHz, 28-Jul-11

<u>Manufacturer</u>	<u>Description</u>	<u>Model</u>	<u>Asset #</u>	<u>Cal Due</u>
Hewlett Packard	Microwave Preamplifier, 1-26.5GHz	8449B	785	5/18/2012
EMCO	Antenna, Horn, 1-18 GHz (SA40-Blu)	3115	1386	9/21/2012
Hewlett Packard	SpecAn 9 kHz - 40 GHz, FT (SA40) Blue	8564E (84125C)	1393	8/14/2011
Micro-Tronics	Band Reject Filter, 2400-2500 MHz	BRM50702-02	1683	8/10/2011

Radiated Emissions, 30 - 6,000 MHz, 28-Jul-11

<u>Manufacturer</u>	<u>Description</u>	<u>Model</u>	<u>Asset #</u>	<u>Cal Due</u>
Hewlett Packard	Microwave Preamplifier, 1-26.5GHz	8449B	785	5/18/2012
Hewlett Packard	EMC Spectrum Analyzer, 9 KHz - 22 GHz	8593EM	1319	11/22/2011
Rohde & Schwarz	Test Receiver, 0.009-2750 MHz	ESN	1332	1/17/2012
Hewlett Packard	SpecAn 9 kHz - 40 GHz, FT (SA40) Blue	8564E (84125C)	1393	8/14/2011
Sunol Sciences	Biconilog, 30-3000 MHz	JB3	1548	6/24/2012
EMCO	Antenna, Horn, 1-18 GHz	3115	1561	6/22/2012
Com-Power Corp.	Preamplifier, 30-1000 MHz	PA-103	1632	4/29/2012

Conducted Emissions - AC Power Ports, 28-Jul-11

<u>Manufacturer</u>	<u>Description</u>	<u>Model</u>	<u>Asset #</u>	<u>Cal Due</u>
EMCO	LISN, 10 kHz-100 MHz	3825/2	1293	3/1/2012
Hewlett Packard	EMC Spectrum Analyzer, 9 KHz - 22 GHz	8593EM	1319	11/22/2011
Rohde & Schwarz	Test Receiver, 0.009-2750 MHz	ESN	1332	1/17/2012
Rohde & Schwarz	Pulse Limiter	ESH3 Z2	1594	5/17/2012

Radio Antenna Port (Power and Spurious Emissions), 02-Aug-11

<u>Manufacturer</u>	<u>Description</u>	<u>Model</u>	<u>Asset #</u>	<u>Cal Due</u>
Agilent	PSA, Spectrum Analyzer, (installed options, 111, 115, 123, 1DS, B7J, HYX,	E4446A	2139	1/26/2012

Radiated Emissions, 30 - 26,500 MHz, 09-Aug-11

<u>Manufacturer</u>	<u>Description</u>	<u>Model</u>	<u>Asset #</u>	<u>Cal Due</u>
Hewlett Packard	Microwave Preamplifier, 1-26.5GHz	8449B	263	12/8/2011
EMCO	Antenna, Horn, 1-18GHz	3115	868	6/8/2012
Hewlett Packard	SpecAn 30 Hz -40 GHz, SV (SA40) Red	8564E (84125C)	1148	8/12/2011
Sunol Sciences	Biconilog, 30-3000 MHz	JB3	1657	5/28/2012
Rohde & Schwarz	EMI Test Receiver, 20 Hz-7 GHz	ESIB7	1756	4/6/2012
Micro-Tronics	Band Reject Filter, 2400-2500 MHz	BRM50702-02	2238	10/1/2011
Com-Power Corp.	Preamplifier, 30-1000 MHz	PA-103A	2359	2/15/2012

Fundamental, 11-Aug-11

<u>Manufacturer</u>	<u>Description</u>	<u>Model</u>	<u>Asset #</u>	<u>Cal Due</u>
Rohde & Schwarz	EMI Test Receiver, 20 Hz-7 GHz	ESIB7	1538	11/2/2011
Sunol Sciences	Biconilog, 30-3000 MHz	JB3	2197	12/29/2011

Radiated Emissions, Power, 15-Aug-11

<u>Manufacturer</u>	<u>Description</u>	<u>Model</u>	<u>Asset #</u>	<u>Cal Due</u>
EMCO	Antenna, Horn, 1-18 GHz	3115	487	7/6/2012
Rohde & Schwarz	EMI Test Receiver, 20 Hz-7 GHz	ESIB7	1538	11/2/2011

Radiated Emissions, Fundamental and 1,500 - 20,000 MHz, 22-Aug-11

<u>Manufacturer</u>	<u>Description</u>	<u>Model</u>	<u>Asset #</u>	<u>Cal Due</u>
Hewlett Packard	SpecAn 9 KHz-26.5 GHz, Non-Program	8563E	284	1/13/2012
Hewlett Packard	Microwave Preamplifier, 1-26.5GHz	8449B	870	2/28/2012
Hewlett Packard	High Pass filter, 3.5 GHz	P/N 84300-80038	1157	8/5/2012
EMCO	Antenna, Horn, 1-18 GHz (SA40-Blu)	3115	1386	9/21/2012
Rohde & Schwarz	EMI Test Receiver, 20 Hz-7 GHz	ESIB7	1630	4/13/2012
Hewlett Packard	High Pass filter, 1.5 GHz (Purple System)	P/N 84300-80037 (84125C)	1769	11/29/2011
Sunol Sciences	Biconilog, 30-3000 MHz	JB3	2237	7/14/2012

Appendix B Test Data

T84001 Pages 25 - 40



EMC Test Data

Client:	Ricoh	Job Number:	J83980
Model:	eQ102 (FCC ID: BBP-WLNEWS102)	T-Log Number:	T84001
		Account Manager:	Christine Krebill
Contact:	Jay Moulton @ RF Exposure		
Emissions Standard(s):	FCC part 15.b, FCC 15.247, 15.E, Part 22/24	Class:	B

EMC Test Data

For The

Ricoh

Model

eQ102 (FCC ID: BBP-WLNEWS102)

Date of Last Test: 9/1/2011

Client: Ricoh	Job Number: J83980
Model: eQ102 (FCC ID: BBP-WLNEWS102)	T-Log Number: T84001
Contact: Jay Moulton @ RF Exposure	Account Manager: Christine Krebill
Standard: FCC part 15.b, FCC 15.247, 15.E, Part 22/24	Class: B

Run #1: AC Power Port Conducted Emissions, 0.15 - 30MHz, 120V/60Hz

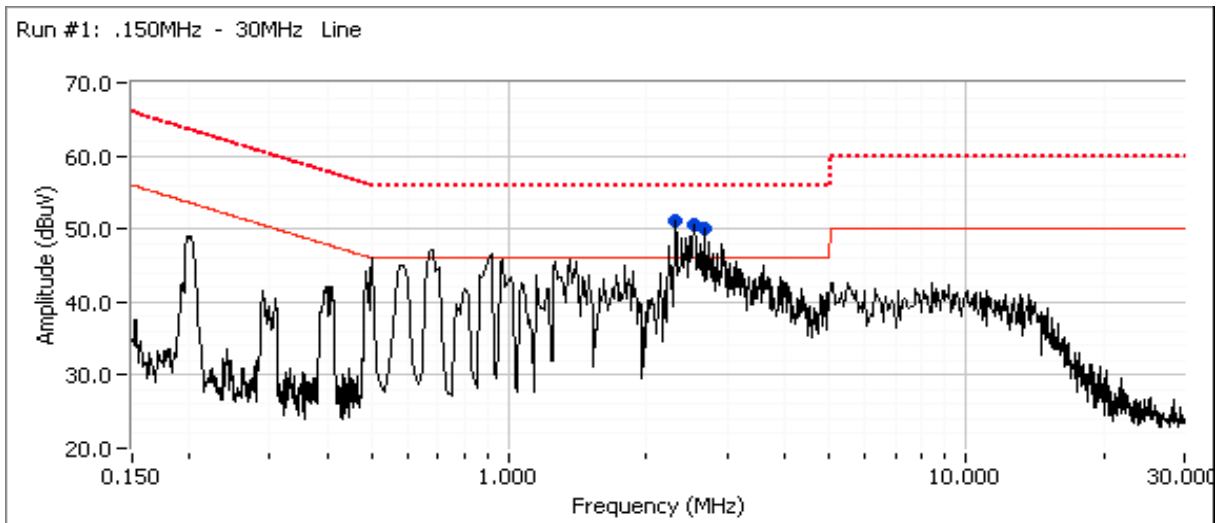
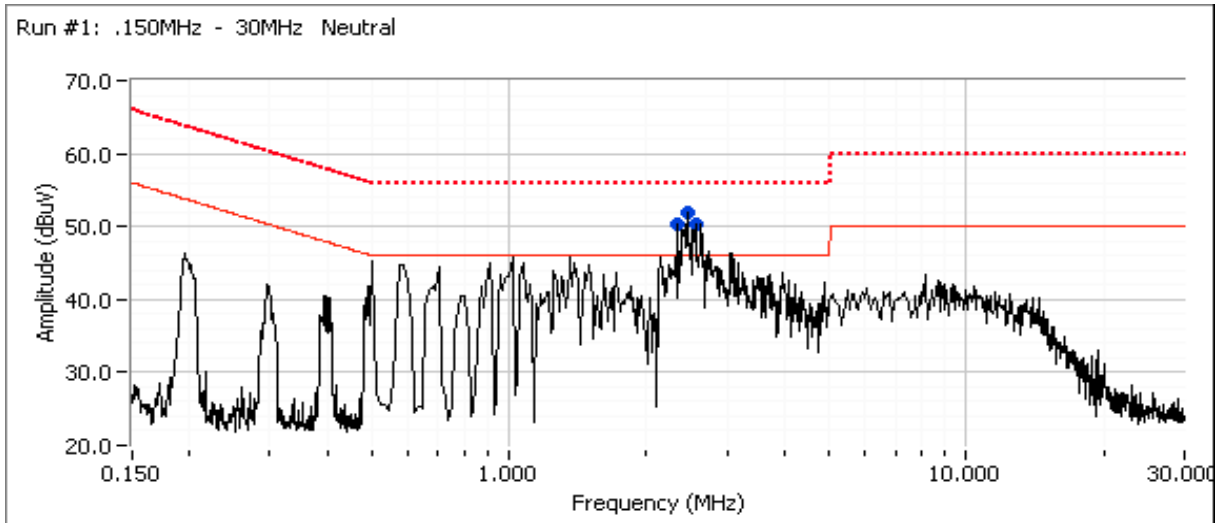

Client: Ricoh	Job Number: J83980
Model: eQ102 (FCC ID: BBP-WLNEWS102)	T-Log Number: T84001
	Account Manager: Christine Krebill
Contact: Jay Moulton @ RF Exposure	
Standard: FCC part 15.b, FCC 15.247, 15.E, Part 22/24	Class: B

Run #1: AC Power Port Conducted Emissions, 0.15 - 30MHz, 120V/60Hz

Preliminary peak readings captured during pre-scan (peak readings vs. average limit)

Frequency MHz	Level dB μ V	AC Line	FCC Class B		Detector QP/Ave	Comments
			Limit	Margin		
2.451	51.8	Neutral	46.0	5.8	Peak	
2.322	51.1	Line 1	46.0	5.1	Peak	
2.554	50.5	Line 1	46.0	4.5	Peak	
2.555	50.4	Neutral	46.0	4.4	Peak	
2.326	50.4	Neutral	46.0	4.4	Peak	
2.667	50.1	Line 1	46.0	4.1	Peak	

Final quasi-peak and average readings

Frequency MHz	Level dB μ V	AC Line	FCC Class B		Detector QP/Ave	Comments
			Limit	Margin		
2.451	47.5	Neutral	56.0	-8.5	QP	QP (1.00s)
2.326	46.0	Neutral	56.0	-10.0	QP	QP (1.00s)
2.555	45.6	Neutral	56.0	-10.4	QP	QP (1.00s)
2.554	45.5	Line 1	56.0	-10.5	QP	QP (1.00s)
2.322	45.4	Line 1	56.0	-10.6	QP	QP (1.00s)
2.667	42.7	Line 1	56.0	-13.3	QP	QP (1.00s)
2.326	31.7	Neutral	46.0	-14.3	AVG	AVG (0.10s)
2.451	31.2	Neutral	46.0	-14.8	AVG	AVG (0.10s)
2.555	30.8	Neutral	46.0	-15.2	AVG	AVG (0.10s)
2.554	30.7	Line 1	46.0	-15.3	AVG	AVG (0.10s)
2.322	28.5	Line 1	46.0	-17.5	AVG	AVG (0.10s)
2.667	23.5	Line 1	46.0	-22.5	AVG	AVG (0.10s)

Client:	Ricoh	Job Number:	J83980
Model:	eQ102 (FCC ID: BBP-WLNEWS102)	T-Log Number:	T84001
Contact:	Jay Moulton @ RF Exposure	Account Manager:	Christine Krebill
Standard:	FCC part 15.b, FCC 15.247, 15.E, Part 22/24	Class:	N/A

FCC 15.247 FHSS - Power, Bandwidth and Spurious Emissions

Test Specific Details

Objective: The objective of this test session is to perform final qualification testing of the EUT with respect to the specification listed above.

General Test Configuration

When measuring the conducted emissions from the EUT's antenna port, the antenna port of the EUT was connected to the spectrum analyzer or power meter via a suitable attenuator to prevent overloading the measurement system. All measurements are corrected to allow for the external attenuators used.

Unless stated otherwise the EUT was operating such that it constantly hopped on either the low, center or high channels.

Ambient Conditions: Temperature: 20-25 °C
 Rel. Humidity: 30-40 %

Summary of Results

Run #	Test Performed	Limit	Pass / Fail	Result / Margin
1	30 - 26500 MHz - Transmitter Conducted Spurious Emissions	FCC Part 15.247(c)	PASS	All signals were more than 10dB below the limit
4	Output Power	15.247(b)	PASS	9.78dBm (9.5mW)
5	20dB Bandwidth	15.247(a)	PASS	1436 kHz
5	99% bandwidth	15.247(a)	PASS	1270 kHz
5	Number of Channels	15.247(a)	PASS	79

Modifications Made During Testing:

No modifications were made to the EUT during testing

Deviations From The Standard

No deviations were made from the requirements of the standard.

Client:	Ricoh	Job Number:	J83980
Model:	eQ102 (FCC ID: BBP-WLNEWS102)	T-Log Number:	T84001
Contact:	Jay Moulton @ RF Exposure	Account Manager:	Christine Krebill
Standard:	FCC part 15.b, FCC 15.247, 15.E, Part 22/24	Class:	N/A

Run #1: Antenna Conducted Spurious Emissions, 30 - 26500 MHz.

Date of Test: 8/2/2011

Test Location: FT Lab #4

Test Engineer: M. Birgani

Refer to plots below. Scans made using RBW=VB=100 KHz with the limit line set at 20dB below the highest in-band signal level with the hopping feature disabled.

Low channel

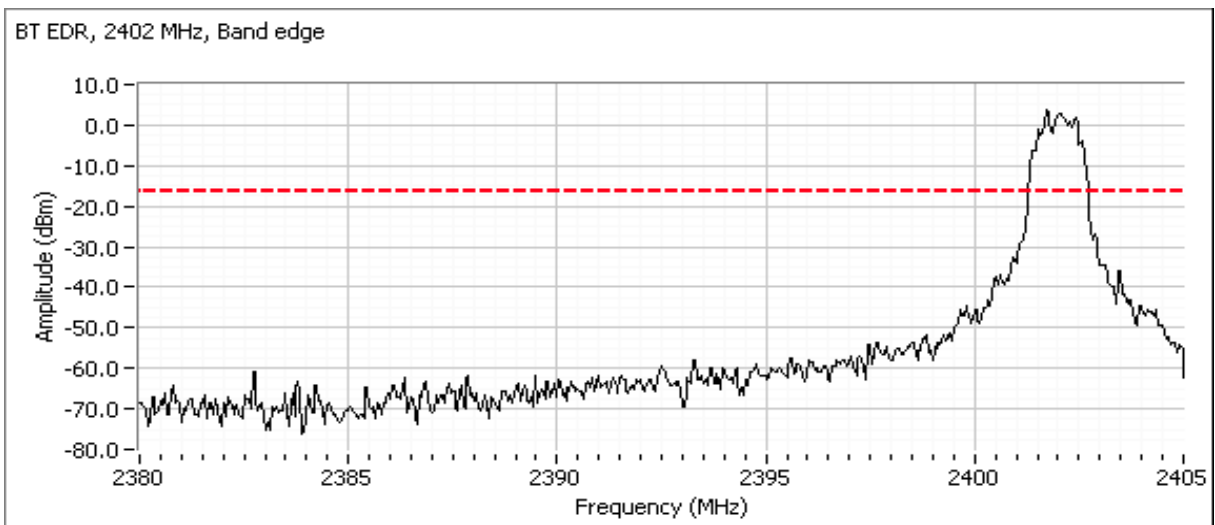
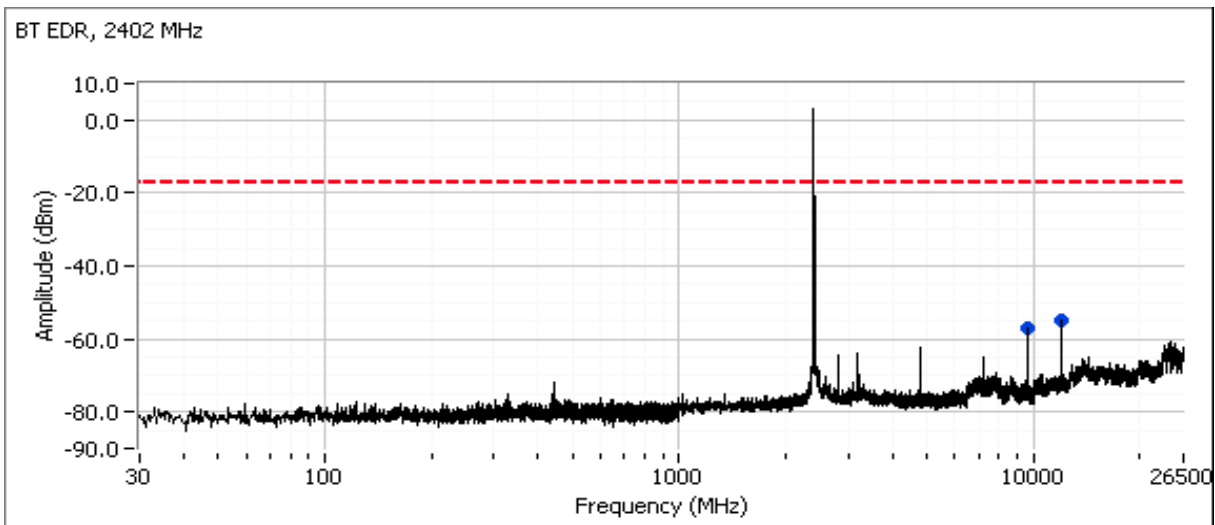

Plot showing -20dBc at the lower band edge

Client: Ricoh	Job Number: J83980
Model: eQ102 (FCC ID: BBP-WLNEWS102)	T-Log Number: T84001
Contact: Jay Moulton @ RF Exposure	Account Manager: Christine Krebill
Standard: FCC part 15.b, FCC 15.247, 15.E, Part 22/24	Class: N/A

Center channel

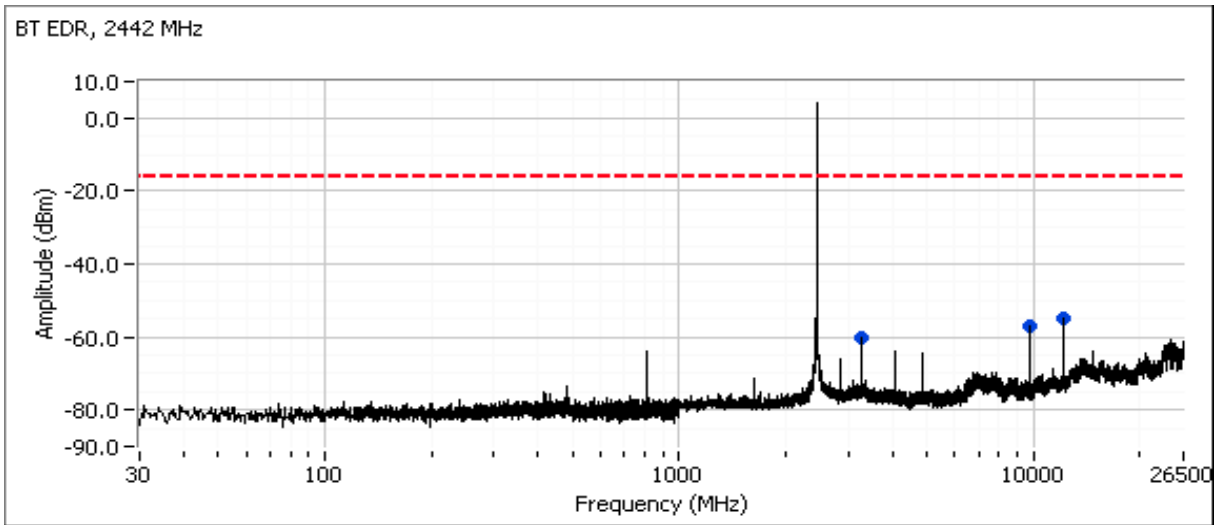

High channel

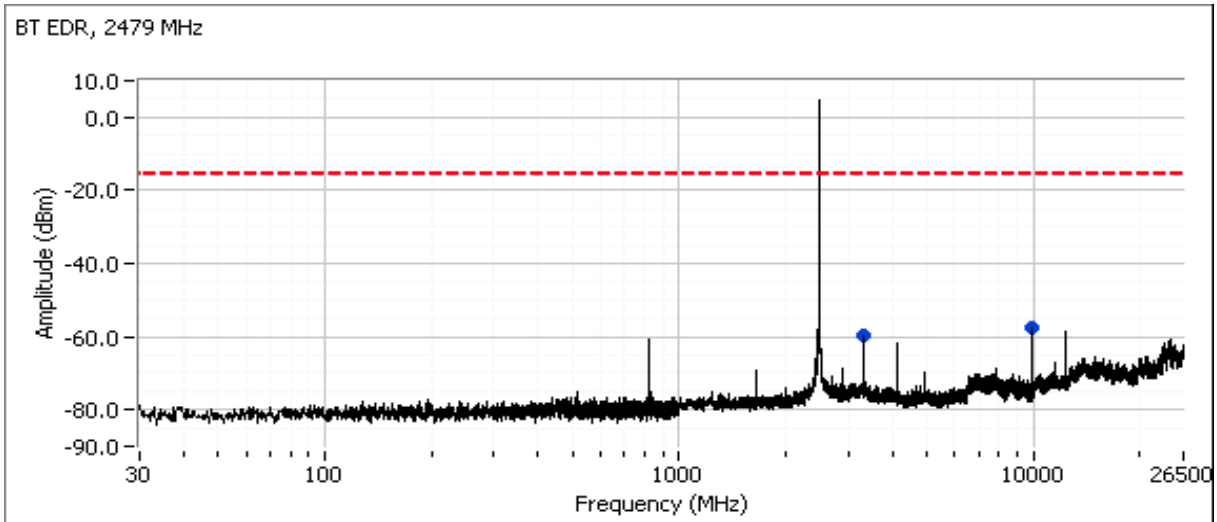

Client: Ricoh	Job Number: J83980
Model: eQ102 (FCC ID: BBP-WLNEWS102)	T-Log Number: T84001
Contact: Jay Moulton @ RF Exposure	Account Manager: Christine Krebill
Standard: FCC part 15.b, FCC 15.247, 15.E, Part 22/24	Class: N/A

Plot showing -20dBc at the upper band edge

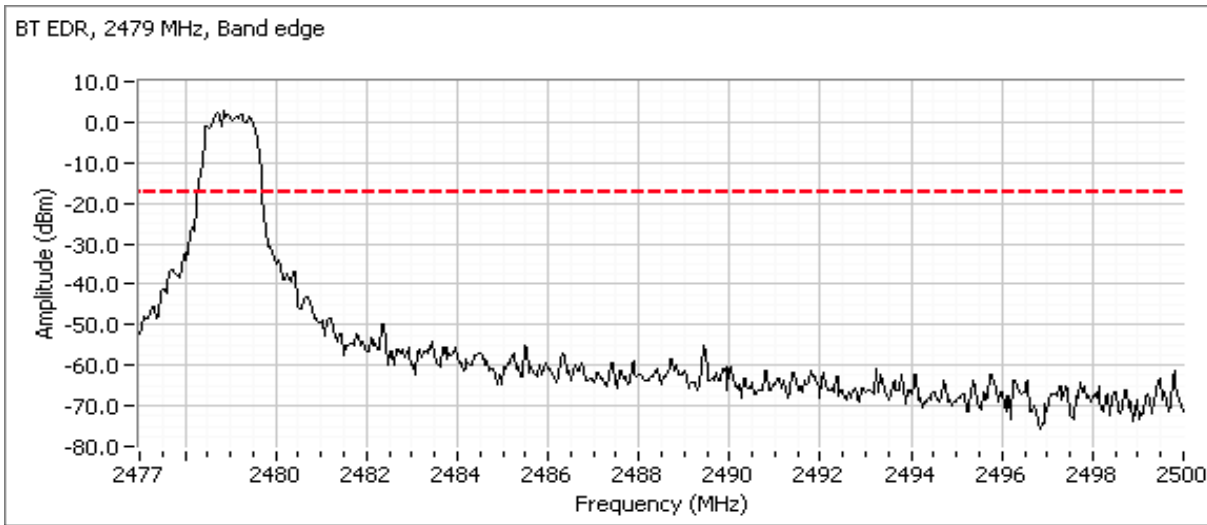

Run #2: Output Power

Date of Test: 8/2/2011
 Test Engineer: M. Birgani

Test Location: FT Lab #4

For frequency hopping systems operating in the 2400-2483.5 MHz band employing at least 75 non-overlapping hopping channels
 For all other frequency hopping systems in the 2400-2483.5 MHz band: 0.125 watts.

Maximum antenna gain: 2.2 dBi

Channel	Frequency (MHz)	Res BW	Output Power (dBm)	Output Power (W)	EIRP (W)
Low	2402	2MHz	9.35	0.0086	0.0143
Mid	2442	2MHz	9.78	0.0095	0.0158
High	2479	2MHz	9.63	0.0092	0.0152

Client: Ricoh	Job Number: J83980
Model: eQ102 (FCC ID: BBP-WLNEWS102)	T-Log Number: T84001
Contact: Jay Moulton @ RF Exposure	Account Manager: Christine Krebill
Standard: FCC part 15.b, FCC 15.247, 15.E, Part 22/24	Class: N/A

Run #3: Bandwidth, Channel Occupancy, Spacing and Number of Channels

Date of Test: 8/2/2011

Test Location: FT Lab #4

Test Engineer: M. Birgani

Channel	Frequency (MHz)	Resolution Bandwidth	20dB Bandwidth (kHz)	Resolution Bandwidth	99% Bandwidth (kHz)
Low	2402	100kHz	1436	100kHz	1270
Mid	2442	100kHz	1426	100kHz	1260
High	2479	100kHz	1426	100kHz	1260

Note 1: 99% and 20dB bandwidth measured using RB = 100kHz, VB = 300kHz

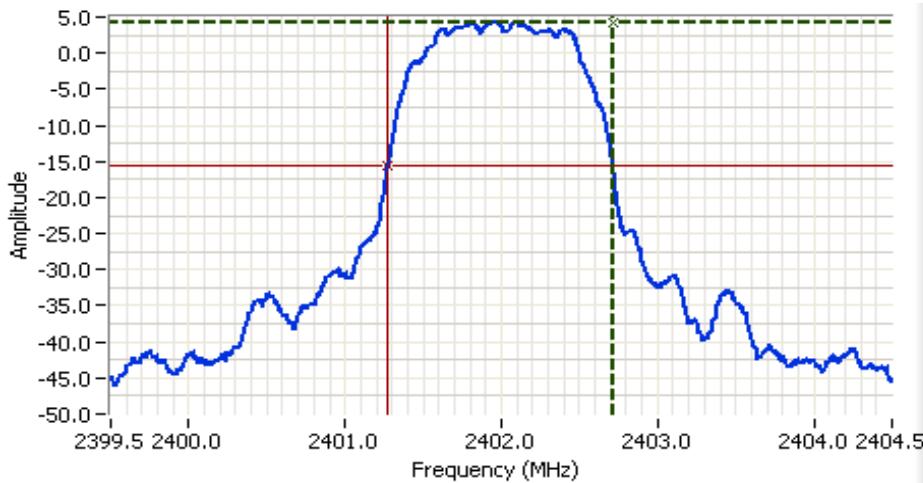

Analyzer Settings
 Agilent Technologies, E4446A
 CF: 2402.000 MHz
 SPAN: 5.000 MHz
 RB: 100 kHz
 VB: 300 kHz
 Detector: POS
 Attn: 20 DB
 RL Offset: 6.4 DB
 Sweep Time: 1.1ms
 Ref Lvl: 14.4 DBM

Comments
 20dB BW: 1.436 MHz
 EDR

Cursor 1	2402.7132	4.33	
Cursor 2	2401.2768	-15.66	

Delta Freq. 1.436
 Delta Amplitude 20.00



Client:	Ricoh	Job Number:	J83980
Model:	eQ102 (FCC ID: BBP-WLNEWS102)	T-Log Number:	T84001
		Account Manager:	Christine Krebill
Contact:	Jay Moulton @ RF Exposure		
Standard:	FCC part 15.b, FCC 15.247, 15.E, Part 22/24	Class:	N/A

Frequency hopping systems in the **2400-2483.5 MHz** band shall use at least 15 channels. The average time of occupancy on any channel shall not be greater than 0.4 seconds within a period of 0.4 seconds multiplied by the number of hopping channels employed. (Frequency hopping systems may avoid or suppress transmissions on a particular hopping frequency provided that a minimum of 15 channels are used.)

Results: EUT complies with the Bluetooth protocol which ensures compliance with the timing requirements of 15.247. Plots are provided for number of channels (see BT Basic Antenna Port Results)

Client:	Ricoh	Job Number:	J83980
Model:	eQ102 (FCC ID: BBP-WLNEWS102)	T-Log Number:	T84001
Contact:	Jay Moulton @ RF Exposure	Account Manager:	Christine Krebill
Standard:	FCC part 15.b, FCC 15.247, 15.E, Part 22/24	Class:	N/A

FCC 15.247 FHSS - Power, Bandwidth and Spurious Emissions

Test Specific Details

Objective: The objective of this test session is to perform final qualification testing of the EUT with respect to the specification listed above.

General Test Configuration

The EUT and all local support equipment were located on the turntable for radiated spurious emissions testing.

When measuring the conducted emissions from the EUT's antenna port, the antenna port of the EUT was connected to the spectrum analyzer or power meter via a suitable attenuator to prevent overloading the measurement system. All measurements are corrected to allow for the external attenuators used.

Unless stated otherwise the EUT was operating such that it constantly hopped on either the low, center or high channels.

Ambient Conditions: Temperature: 20-25 °C
 Rel. Humidity: 30-40 %

Summary of Results

Run #	Test Performed	Limit	Pass / Fail	Result / Margin
1	30 - 26500 MHz - Transmitter Conducted Spurious Emissions	FCC Part 15.247(c)	PASS	All signals were more than 10dB below the limit
2	Output Power	15.247(b)	PASS	9.32dBm (8.6mW)
3	20dB Bandwidth	15.247(a)	PASS	1116kHz
3	99% bandwidth	15.247(a)	PASS	945kHz
3	Number of Channels	15.247(a)	PASS	79

Modifications Made During Testing:

No modifications were made to the EUT during testing

Deviations From The Standard

No deviations were made from the requirements of the standard.

Client: Ricoh	Job Number: J83980
Model: eQ102 (FCC ID: BBP-WLNEWS102)	T-Log Number: T84001
Contact: Jay Moulton @ RF Exposure	Account Manager: Christine Krebill
Standard: FCC part 15.b, FCC 15.247, 15.E, Part 22/24	Class: N/A

Run #1: Antenna Conducted Spurious Emissions, 30 - 26500 MHz.

Date of Test: 8/2/2011

Test Location: FT Lab #4

Test Engineer: M. Birgani

Refer to plots below. Scans made using RBW=VB=100 KHz with the limit line set at 20dB below the highest in-band signal level with the hopping feature disabled.

Low channel

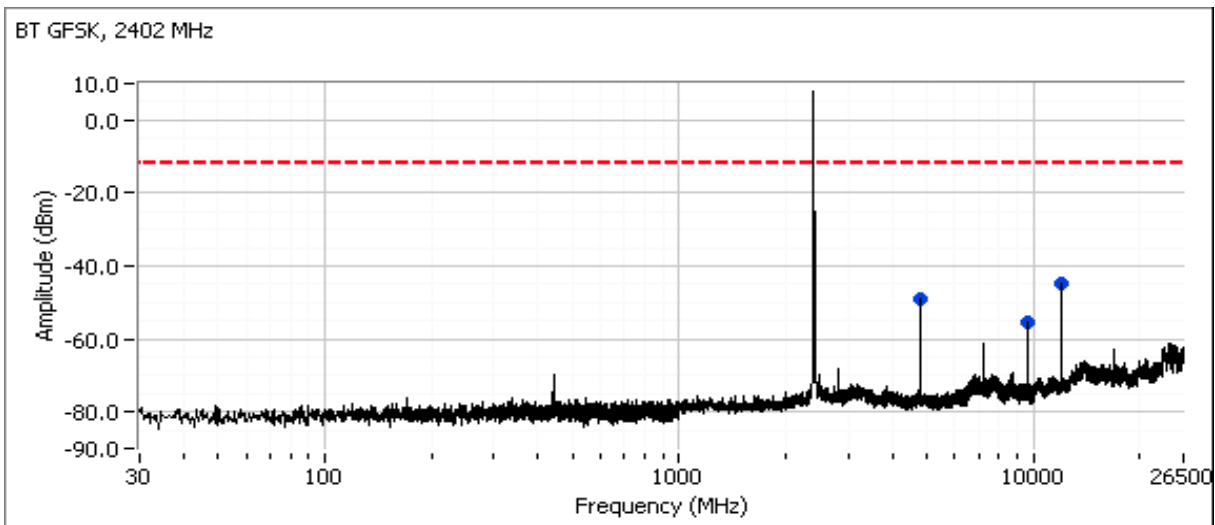

Plot showing -20dBc at the lower band edge

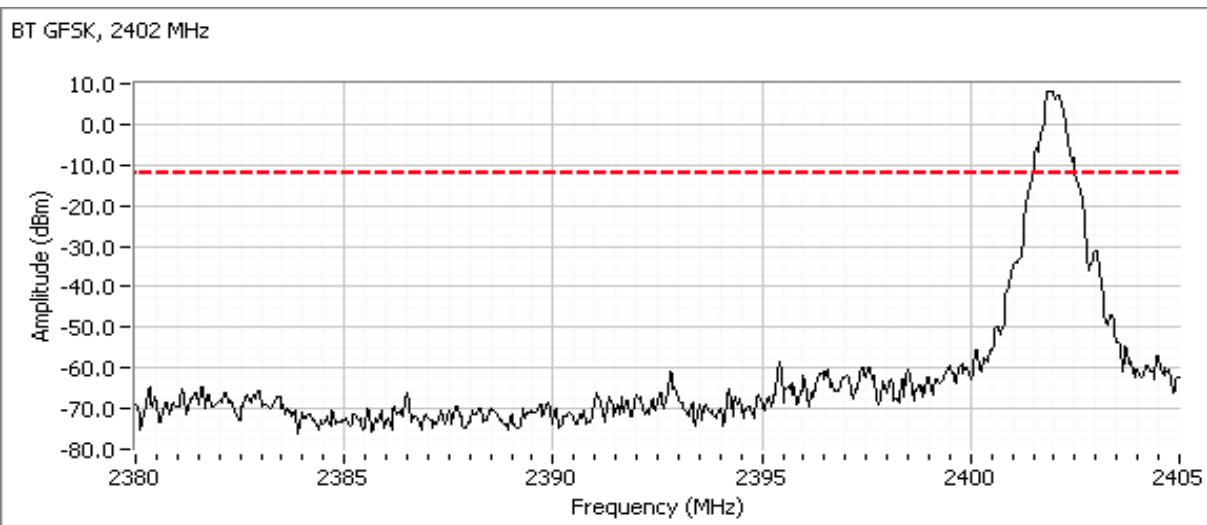

Client: Ricoh	Job Number: J83980
Model: eQ102 (FCC ID: BBP-WLNEWS102)	T-Log Number: T84001
Contact: Jay Moulton @ RF Exposure	Account Manager: Christine Krebill
Standard: FCC part 15.b, FCC 15.247, 15.E, Part 22/24	Class: N/A

Center channel

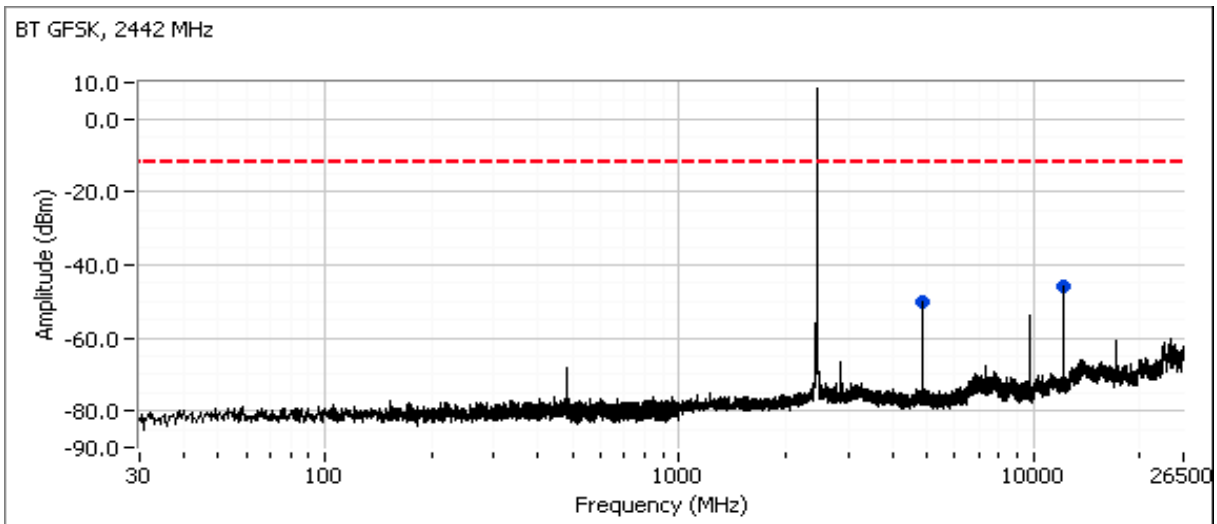

High channel

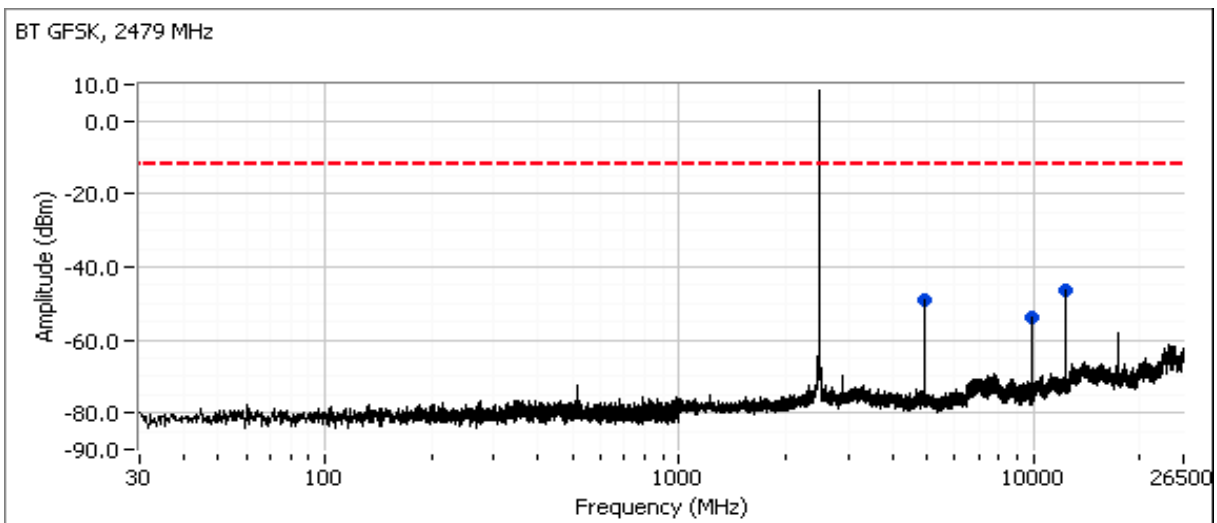

Client: Ricoh	Job Number: J83980
Model: eQ102 (FCC ID: BBP-WLNEWS102)	T-Log Number: T84001
Contact: Jay Moulton @ RF Exposure	Account Manager: Christine Krebill
Standard: FCC part 15.b, FCC 15.247, 15.E, Part 22/24	Class: N/A

Plot showing -20dBc at the upper band edge

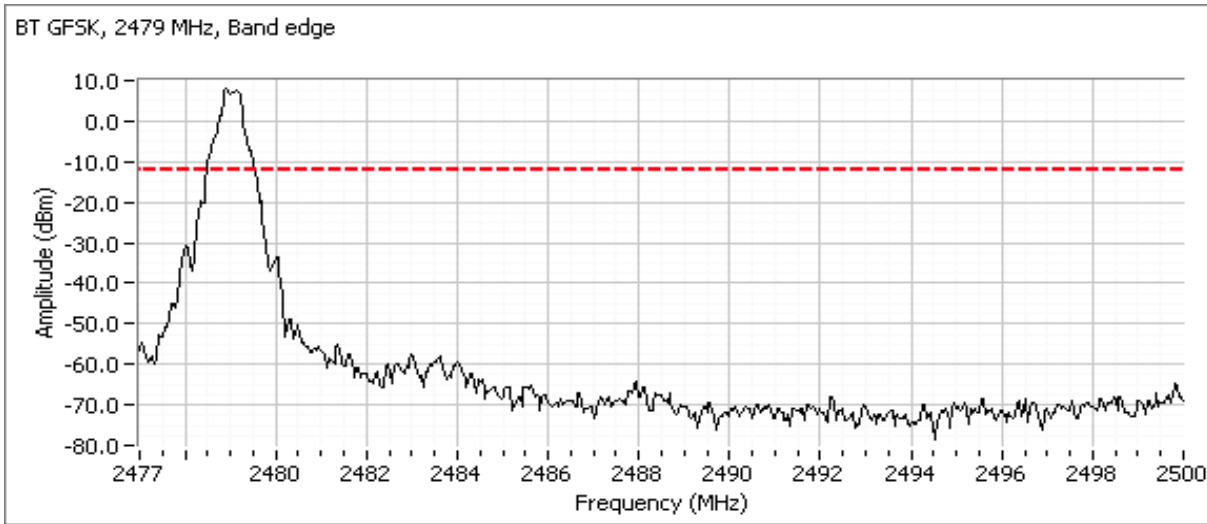

Run #2: Output Power

Date of Test: 8/2/2011
 Test Engineer: M. Birgani

Test Location: FT Lab #4

For frequency hopping systems operating in the 2400-2483.5 MHz band employing at least 75 non-overlapping hopping channels
 For all other frequency hopping systems in the 2400-2483.5 MHz band: 0.125 watts.

Maximum antenna gain: 2.2 dBi

Channel	Frequency (MHz)	Res BW	Output Power (dBm)	Output Power (W)	EIRP (W)
Low	2402	2MHz	8.85	0.0077	0.0127
Mid	2442	2MHz	9.32	0.0086	0.0142
High	2479	2MHz	9.19	0.0083	0.0138

Client: Ricoh	Job Number: J83980
Model: eQ102 (FCC ID: BBP-WLNEWS102)	T-Log Number: T84001
Contact: Jay Moulton @ RF Exposure	Account Manager: Christine Krebill
Standard: FCC part 15.b, FCC 15.247, 15.E, Part 22/24	Class: N/A

Run #3: Bandwidth, Channel Occupancy, Spacing and Number of Channels

Date of Test: 8/2/2011

Test Location: FT Lab #4

Test Engineer: M. Birgani

Channel	Frequency (MHz)	Resolution Bandwidth	20dB Bandwidth (kHz)	Resolution Bandwidth	99% Bandwidth (kHz)
Low	2402	100kHz	1116	100kHz	940
Mid	2442	100kHz	1106	100kHz	945
High	2479	100kHz	1101	100kHz	940

Note 1: 99% and 20dB bandwidth measured using RB = 100kHz, VB = 300kHz

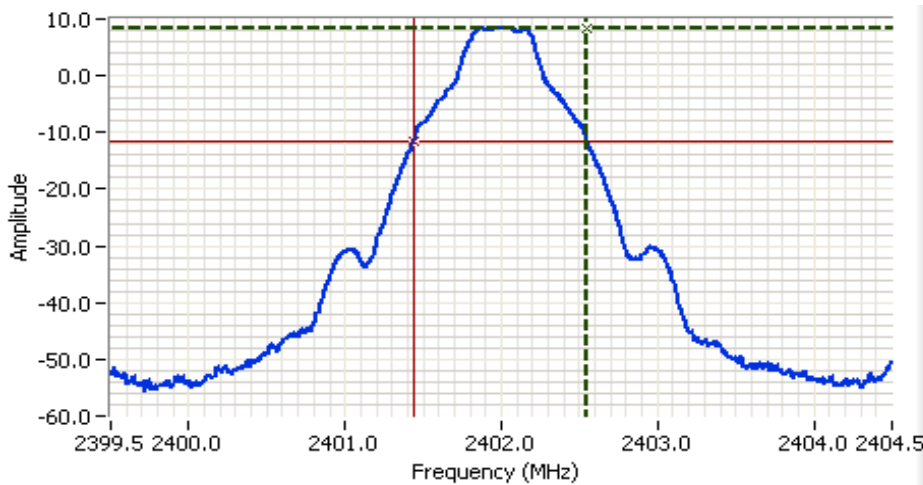

Analyzer Settings
 Agilent Technologies, E4446A
 CF: 2402.000 MHz
 SPAN: 5.000 MHz
 RB: 100 kHz
 VB: 300 kHz
 Detector: POS
 Attn: 20 DB
 RL Offset: 6.4 DB
 Sweep Time: 1.1ms
 Ref Lvl: 14.4 DBM

Comments
 20dB BW: 1.116 MHz
 GFSK

Cursor 1	2402.5531	8.44	+	-	↕
Cursor 2	2401.4369	-11.56	+	-	↕

Delta Freq. 1.116
 Delta Amplitude 20.00



Client:	Ricoh	Job Number:	J83980
Model:	eQ102 (FCC ID: BBP-WLNEWS102)	T-Log Number:	T84001
Contact:	Jay Moulton @ RF Exposure	Account Manager:	Christine Krebill
Standard:	FCC part 15.b, FCC 15.247, 15.E, Part 22/24	Class:	N/A

Frequency hopping systems in the 2400-2483.5 MHz band shall use at least 15 channels. The average time of occupancy on any channel shall not be greater than 0.4 seconds within a period of 0.4 seconds multiplied by the number of hopping channels employed. (Frequency hopping systems may avoid or suppress transmissions on a particular hopping frequency provided that a minimum of 15 channels are used.)

Results: EUT complies with the Bluetooth protocol which ensures compliance with the timing requirements of 15.247. Plots are provided for number of channels (see BT Basic Antenna Port Results)

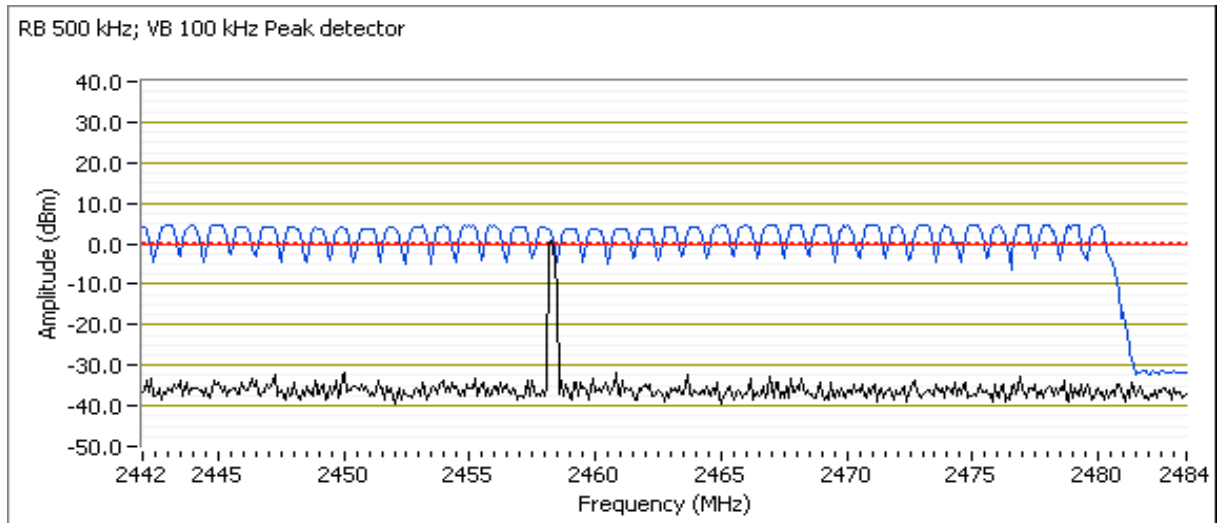
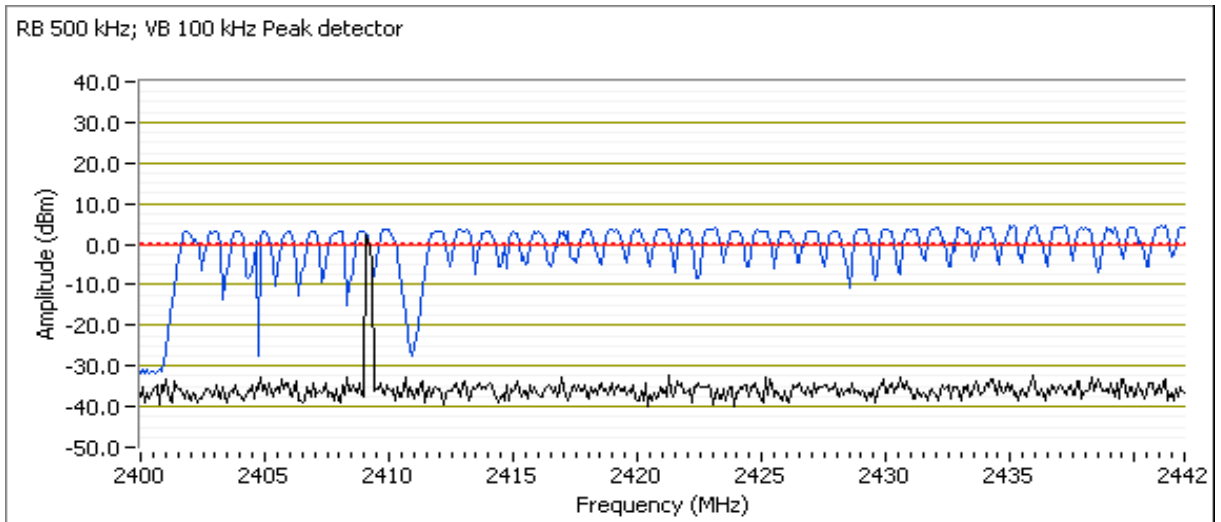

End of Report

This page is intentionally blank and marks the last page of this test report.