

FCC Radio Test Report

FCC ID: BBP-WLEIG01

Report No. : BTL-FCCP-1-2207T020
Equipment : portable monitor
Model Name : RICOH Portable Monitor 150BW, RICOH Light Monitor 150BW
Brand Name : RICOH
Applicant : Ricoh Company Ltd
Address : 2-7-1 Izumi Ebina, Kanagawa, 243-0460 Japan

Radio Function : WLAN 2.4 GHz

FCC Rule Part(s) : FCC CFR Title 47, Part 15, Subpart C (15.247)
Measurement Procedure(s) : ANSI C63.10-2013

Date of Receipt : 2022/7/8
Date of Test : 2022/7/8~ 2023/3/28
Issued Date : 2023/3/29

The above equipment has been tested and found in compliance with the requirement of the above standards by BTL Inc.

Prepared by :

Eric Lee

Eric Lee, Engineer

Approved by :

Jerry Chang

Jerry Chuang, Supervisor



BTL Inc.

No.18, Ln. 171, Sec. 2, Jiuzong Rd., Neihu Dist., Taipei City 114, Taiwan

Tel: +886-2-2657-3299 Fax: +886-2-2657-3331 Web: www.newbtl.com Service mail: btl_qa@newbtl.com

Declaration

BTL represents to the client that testing is done in accordance with standard procedures as applicable and that test instruments used has been calibrated with standards traceable to international standard(s) and/or national standard(s).

BTL's reports apply only to the specific samples tested under conditions. It is manufacture's responsibility to ensure that additional production units of this model are manufactured with the identical electrical and mechanical components. **BTL** shall have no liability for any declarations, inferences or generalizations drawn by the client or others from **BTL** issued reports.

This report is the confidential property of the client. As a mutual protection to the clients, the public and ourselves, the test report shall not be reproduced, except in full, without our written approval.

BTL's laboratory quality assurance procedures are in compliance with the **ISO/IEC 17025** requirements, and accredited by the conformity assessment authorities listed in this test report.

BTL is not responsible for the sampling stage, so the results only apply to the sample as received.

The information, data and test plan are provided by manufacturer which may affect the validity of results, so it is manufacturer's responsibility to ensure that the apparatus meets the essential requirements of applied standards and in all the possible configurations as representative of its intended use.

Limitation

For the use of the authority's logo is limited unless the Test Standard(s)/Scope(s)/Item(s) mentioned in this test report is (are) included in the conformity assessment authorities acceptance respective.

Please note that the measurement uncertainty is provided for informational purpose only and are not use in determining the Pass/Fail results.

CONTENTS

REVISION HISTORY	5
1 SUMMARY OF TEST RESULTS	6
1.1 TEST FACILITY	7
1.2 MEASUREMENT UNCERTAINTY	7
1.3 TEST ENVIRONMENT CONDITIONS	7
1.4 TABLE OF PARAMETERS OF TEXT SOFTWARE SETTING	8
1.5 DUTY CYCLE	9
2 GENERAL INFORMATION	10
2.1 DESCRIPTION OF EUT	10
2.2 TEST MODES	12
2.3 BLOCK DIAGRAM SHOWING THE CONFIGURATION OF SYSTEM TESTED	13
2.4 SUPPORT UNITS	14
3 AC POWER LINE CONDUCTED EMISSIONS TEST	16
3.1 LIMIT	16
3.2 TEST PROCEDURE	16
3.3 DEVIATION FROM TEST STANDARD	16
3.4 TEST SETUP	17
3.5 TEST RESULT	17
4 RADIATED EMISSIONS TEST	18
4.1 LIMIT	18
4.2 TEST PROCEDURE	19
4.3 DEVIATION FROM TEST STANDARD	19
4.4 TEST SETUP	19
4.5 EUT OPERATING CONDITIONS	20
4.6 TEST RESULT – BELOW 30 MHZ	21
4.7 TEST RESULT – 30 MHZ TO 1 GHZ	21
4.8 TEST RESULT – ABOVE 1 GHZ	21
5 BANDWIDTH TEST	22
5.1 LIMIT	22
5.2 TEST PROCEDURE	22
5.3 DEVIATION FROM TEST STANDARD	22
5.4 TEST SETUP	22
5.5 EUT OPERATING CONDITIONS	22
5.6 TEST RESULT	22
6 OUTPUT POWER TEST	23
6.1 LIMIT	23
6.2 TEST PROCEDURE	23
6.3 DEVIATION FROM TEST STANDARD	23
6.4 TEST SETUP	23
6.5 EUT OPERATING CONDITIONS	23
6.6 TEST RESULT	23
7 POWER SPECTRAL DENSITY	24
7.1 LIMIT	24
7.2 TEST PROCEDURE	24
7.3 DEVIATION FROM TEST STANDARD	24
7.4 TEST SETUP	24
7.5 EUT OPERATING CONDITIONS	24
7.6 TEST RESULT	24

8	ANTENNA CONDUCTED SPURIOUS EMISSIONS TEST	25
8.1	LIMIT	25
8.2	TEST PROCEDURE	25
8.3	DEVIATION FROM TEST STANDARD	25
8.4	TEST SETUP	25
8.5	EUT OPERATING CONDITIONS	25
8.6	TEST RESULT	25
9	LIST OF MEASURING EQUIPMENTS	26
10	EUT TEST PHOTO	28
11	EUT PHOTOS	28
APPENDIX A	AC POWER LINE CONDUCTED EMISSIONS	29
APPENDIX B	RADIATED EMISSIONS - 30 MHZ TO 1 GHZ	34
APPENDIX C	RADIATED EMISSIONS - ABOVE 1 GHZ	37
APPENDIX D	BANDWIDTH	62
APPENDIX E	OUTPUT POWER	69
APPENDIX F	POWER SPECTRAL DENSITY	73
APPENDIX G	ANTENNA CONDUCTED SPURIOUS EMISSIONS	80

REVISION HISTORY

Report No.	Version	Description	Issued Date	Note
BTL-FCCP-1-2207T020	R00	Original Report.	2022/10/6	Invalid
BTL-FCCP-1-2207T020	R01	Revised report to address TAF Audit's comments.	2023/3/29	Valid

1 SUMMARY OF TEST RESULTS

Test procedures according to the technical standards.

Standard(s) Section	Description	Test Result	Judgement	Remark
15.207	AC Power Line Conducted Emissions	APPENDIX A	Pass	-----
15.205 15.209 15.247(d)	Radiated Emissions	APPENDIX B APPENDIX C	Pass	-----
15.247(a)	Bandwidth	APPENDIX D	Pass	-----
15.247(b)	Output Power	APPENDIX E	Pass	-----
15.247(e)	Power Spectral Density	APPENDIX F	Pass	-----
15.247(d)	Antenna conducted Spurious Emission	APPENDIX G	Pass	-----
15.203	Antenna Requirement	-----	Pass	-----

NOTE:

- (1) "N/A" denotes test is not applicable in this Test Report.
- (2) The report format version is TP.1.1.1.

1.1 TEST FACILITY

The test locations stated below are under the TAF Accreditation Number 0659.

The test location(s) used to collect the test data in this report are:

No. 72, Ln. 169, Sec. 2, Datong Rd., Xizhi Dist., New Taipei City 221, Taiwan
(FCC DN: TW0659)

C06 CB21 CB22

No. 68-1, Ln. 169, Sec. 2, Datong Rd., Xizhi Dist., New Taipei City 221, Taiwan
(FCC DN: TW0659)

C05 CB08 CB11 CB15 CB16
 SR05

1.2 MEASUREMENT UNCERTAINTY

The reported uncertainty of measurement $y \pm U$, where expanded uncertainty U is based on a standard uncertainty multiplied by a coverage factor of $k = 2$, providing a level of confidence of approximately **95 %**. The measurement instrumentation uncertainty considerations contained in CISPR 16-4-2. The BTL measurement uncertainty is less than the CISPR 16-4-2 U_{cispr} requirement.

A. AC power line conducted emissions test:

Test Site	Method	Measurement Frequency Range	U (dB)
C05	CISPR	150 kHz ~ 30MHz	3.44

B. Radiated emissions test :

Test Site	Measurement Frequency Range	U,(dB)
CB21	0.03 GHz ~ 0.2 GHz	4.17
	0.2 GHz ~ 1 GHz	4.72
	1 GHz ~ 6 GHz	5.21
	6 GHz ~ 18 GHz	5.51
	18 GHz ~ 26 GHz	3.69
	26 GHz ~ 40 GHz	4.23

C. Conducted test :

Test Item	U,(dB)
Occupied Bandwidth	0.5334
Output power	0.3669
Power Spectral Density	0.6591
Conducted Spurious emissions	0.5416
Conducted Band edges	0.5348

NOTE:

Unless specifically mentioned, the uncertainty of measurement has not been taken into account to declare the compliance or non-compliance to the specification.

1.3 TEST ENVIRONMENT CONDITIONS

Test Item	Environment Condition	Test Voltage	Tested by
AC Power Line Conducted Emissions	21 °C, 51 %	AC 120V	Jay Tien
Radiated emissions below 1 GHz	21 °C, 61 %	AC 120V	Mark Wang
Radiated emissions above 1 GHz	25 °C, 60 %	AC 120V	Mark Wang
Bandwidth	23.6 °C, 51 %	AC 120V	Angela Wang
Output Power	23.6 °C, 51 %	AC 120V	Angela Wang
Power Spectral Density	23.6 °C, 51 %	AC 120V	Angela Wang
Antenna conducted Spurious Emission	23.6 °C, 51 %	AC 120V	Angela Wang

1.4 TABLE OF PARAMETERS OF TEXT SOFTWARE SETTING

Antenna	SISO_Main			
Test Software	Tera Term V4.97			
Mode	2412 MHz	2437 MHz	2462 MHz	Data Rate
IEEE 802.11b	14	14	14	1 Mbps

Antenna	SISO_Aux			
Test Software	Tera Term V4.97			
Mode	2412 MHz	2437 MHz	2462 MHz	Data Rate
IEEE 802.11b	14	14	14	1 Mbps

Antenna	MIMO			
Test Software	Tera Term V4.97			
Mode	2412 MHz	2437 MHz	2462 MHz	Data Rate
IEEE 802.11g	12	12	12	6 Mbps
IEEE 802.11n (HT20)	12	12	12	MCS 0

1.5 DUTY CYCLE

If duty cycle is $\geq 98\%$, duty factor is not required.
 If duty cycle is $< 98\%$, duty factor shall be considered.

Remark	Delta 1			Delta 2	On Time/Period	10 log(1/Duty Cycle)
Mode	ON (ms)	Numbers (ON)	On Time (B) (ms)	Period (ON+OFF) (ms)	Duty Cycle (%)	Duty Factor (dB)
IEEE 802.11b_Main	12.480	1	12.480	16.400	76.10%	1.19
IEEE 802.11b_Aux	12.400	1	12.400	16.320	75.98%	1.19
IEEE 802.11g	2.000	1	2.000	8.280	24.15%	6.17
IEEE 802.11n (HT20)	0.680	1	0.680	1.400	48.57%	3.14

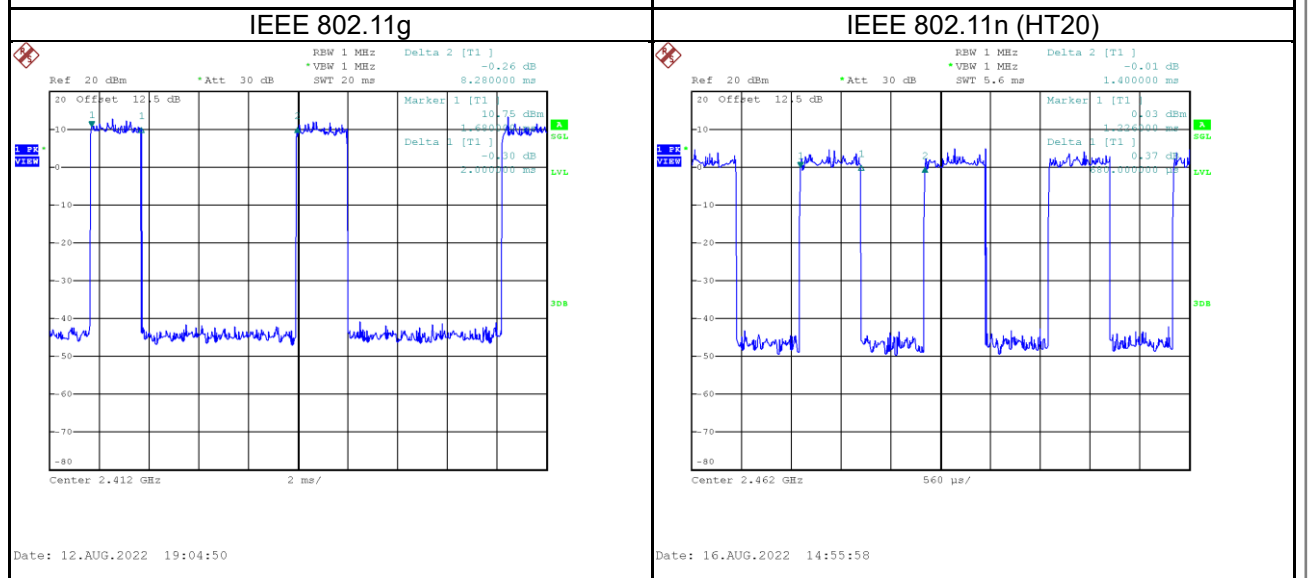
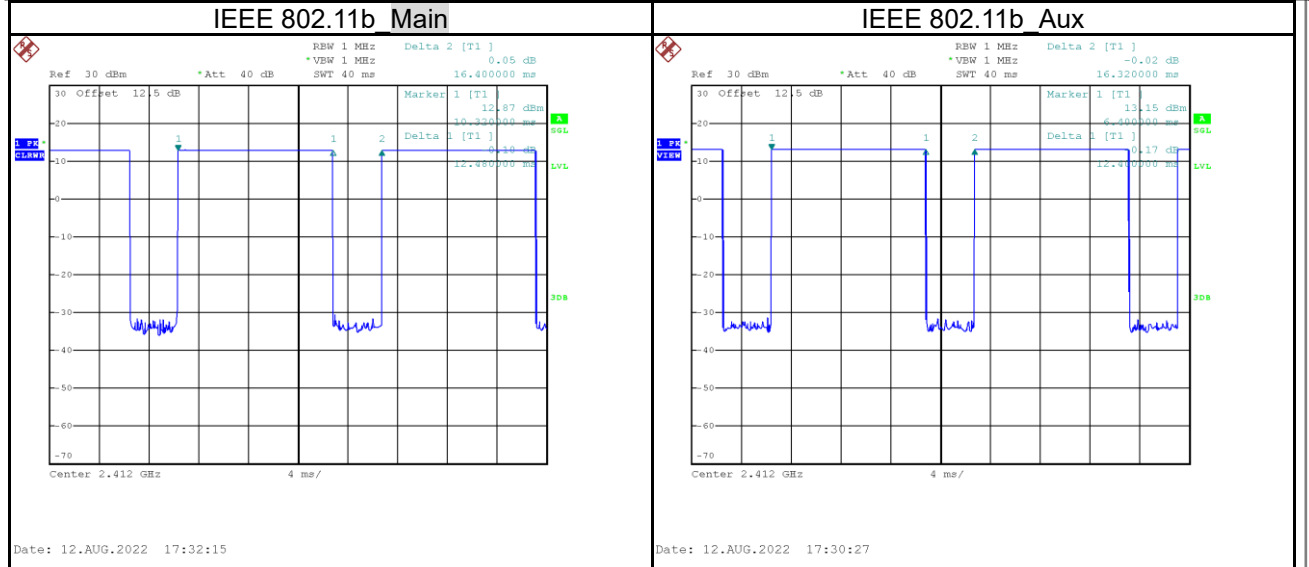

2 GENERAL INFORMATION

2.1 DESCRIPTION OF EUT

Equipment	portable monitor
Model Name	RICOH Portable Monitor 150BW, RICOH Light Monitor 150BW
Brand Name	RICOH
Model Difference	Different model distribute to different area.
Power Source	DC voltage supplied from Type-C port or battery.
Power Rating	IP: DC 5V or 9 V or 15V --- 3 A or 20V --- 2.25A Max.
Products Covered	1 * Type-C Cable
Operation Band	2400 MHz ~ 2483.5 MHz
Operation Frequency	2412 MHz ~ 2462 MHz
Modulation Technology	IEEE 802.11b: DSSS IEEE 802.11g: OFDM IEEE 802.11n: OFDM
Transfer Rate	IEEE 802.11b: 11/5.5/2/1 Mbps IEEE 802.11g: 54/48/36/24/18/12/9/6 Mbps IEEE 802.11n: up to 144.4 Mbps
Output Power Max. -SISO Main	IEEE 802.11b: 17.43 dBm (0.0553 W)
Output Power Max. -SISO Aux	IEEE 802.11b: 17.40 dBm (0.0550 W)
Output Power Max. -MIMO	IEEE 802.11g: 26.93 dBm (0.4928 W) IEEE 802.11n (HT20): 26.87 dBm (0.4864 W)
Test Model	RICOH Portable Monitor 150BW
Sample Status	Engineering Sample
EUT Modification(s)	N/A

NOTE:

(1) The above EUT information is declared by manufacturer and for more detailed features description, please refers to the manufacturer's specifications or user's manual.

(2) Channel List:

CH01 - CH11 for IEEE 802.11b, IEEE 802.11g, IEEE 802.11n (HT20)					
Channel	Frequency (MHz)	Channel	Frequency (MHz)	Channel	Frequency (MHz)
01	2412	05	2432	09	2452
02	2417	06	2437	10	2457
03	2422	07	2442	11	2462
04	2427	08	2447		

(3) Table for Filed Antenna:

Ant.	Manufacturer	Part number	Type	Connector	Frequency (MHz)	Gain (dBi)
Main	Pulse	TZ22940	PIFA	NGFF	2400-2483.5	1.44
Aux	Pulse	TZ22950	PIFA	NGFF	2400-2483.5	1.23

Note:

1) The EUT incorporates a MIMO function. Physically, the EUT provides two completed transmitters and receivers (2T2R).

$$\text{Directional gain} = 10 \cdot \log\{[10^{(G1/20)} + 10^{(G2/20)} + \dots + 10^{(Gn/20)}]^2 / NANT\} = 4.35 \text{ dBi} < 6 \text{ dBi}$$

(4) The above Antenna information are derived from the antenna data sheet provided by manufacturer and for more detailed features description, please refer to the manufacturer's specifications, the laboratory shall not be held responsible.

(5) Operating Mode and Antenna Configuration

Operating Mode	TX Mode	2TX
IEEE 802.11b		V (Main or Aux)
IEEE 802.11g		V (Main or Aux or Main + Aux)
IEEE 802.11n (HT20)		V (Main or Aux or Main + Aux)

2.2 TEST MODES

Test Items	Test mode	Channel	Note
AC power line conducted emissions	Normal/Idle	-	-
Transmitter Radiated Emissions (below 1GHz)	TX Mode_IEEE 802.11b	06	-
Transmitter Radiated Emissions (above 1GHz)	TX Mode_IEEE 802.11b	01/11	Bandedge
	TX Mode_IEEE 802.11g		
	TX Mode_IEEE 802.11n (HT20)		
Transmitter Radiated Emissions (above 1GHz)	TX Mode_IEEE 802.11b	01/06/11	Harmonic
	TX Mode_IEEE 802.11g		
	TX Mode_IEEE 802.11n (HT20)		
Bandwidth & Output Power & Power Spectral Density & Antenna conducted Spurious Emission	TX Mode_IEEE 802.11b	01/06/11	-
	TX Mode_IEEE 802.11g		
	TX Mode_IEEE 802.11n (HT20)		

NOTE:

- (1) For radiated emission band edge test, both Vertical and Horizontal are evaluated, but only the worst case (Horizontal) is recorded.
- (2) All X, Y and Z axes are evaluated, but only the worst case (Y axis) is recorded.

2.3 BLOCK DIAGRAM SHOWING THE CONFIGURATION OF SYSTEM TESTED

Equipment letters and Cable numbers refer to item numbers described in the tables of clause 2.4.

AC power line conducted emissions

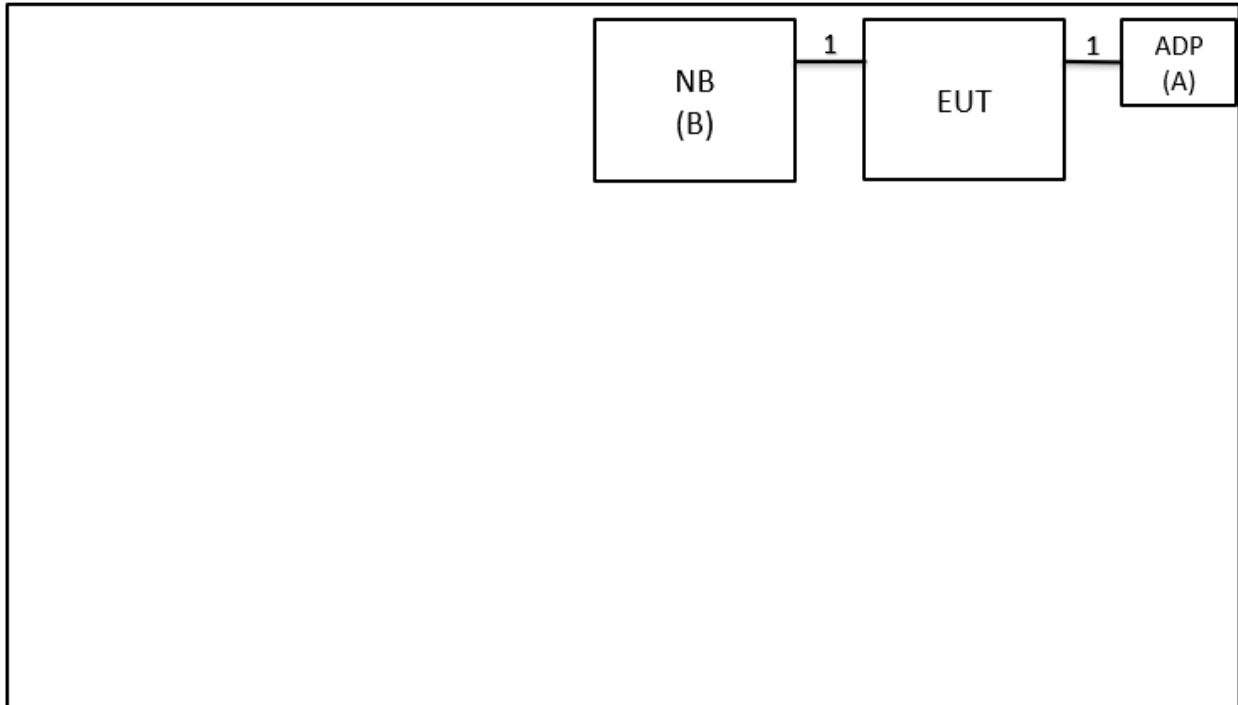

Radiated Emissions (below 1GHz)

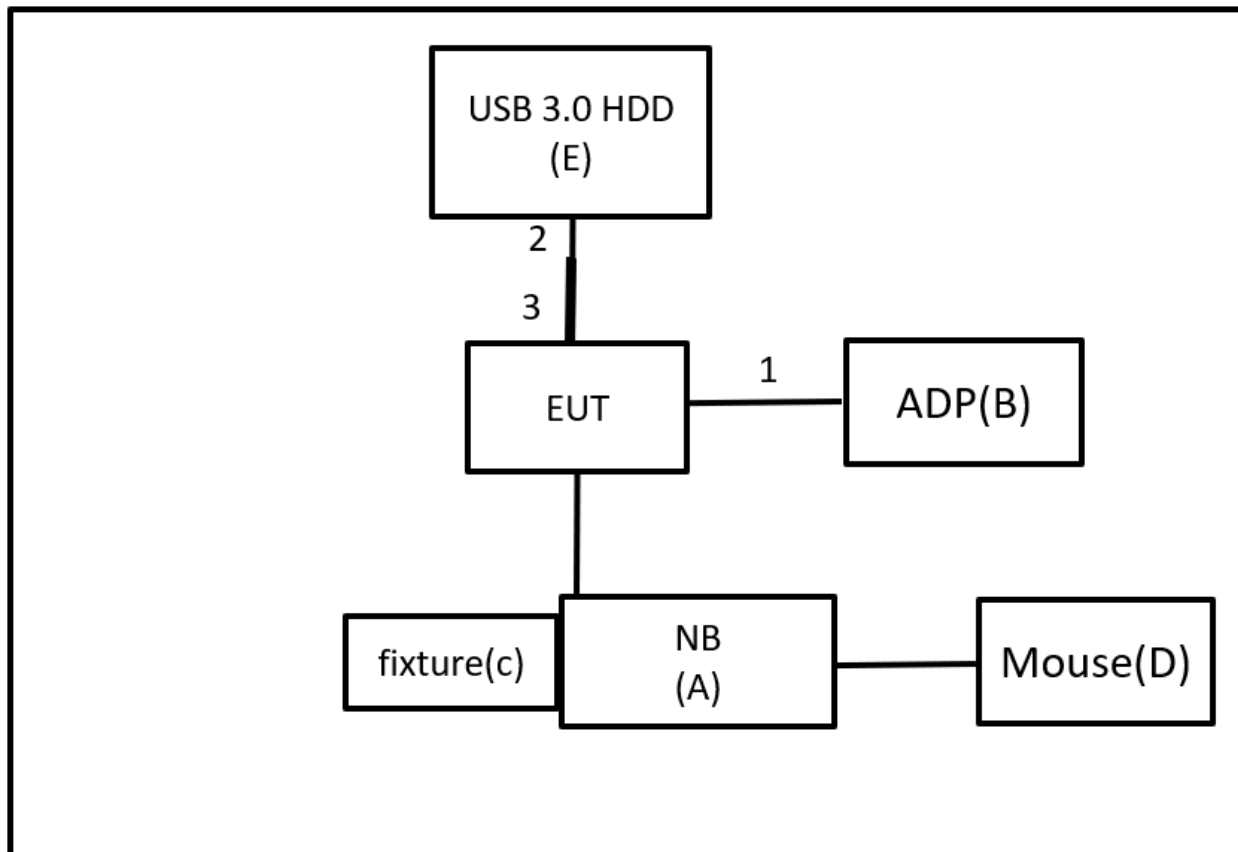

Radiated Emissions (above 1GHz)

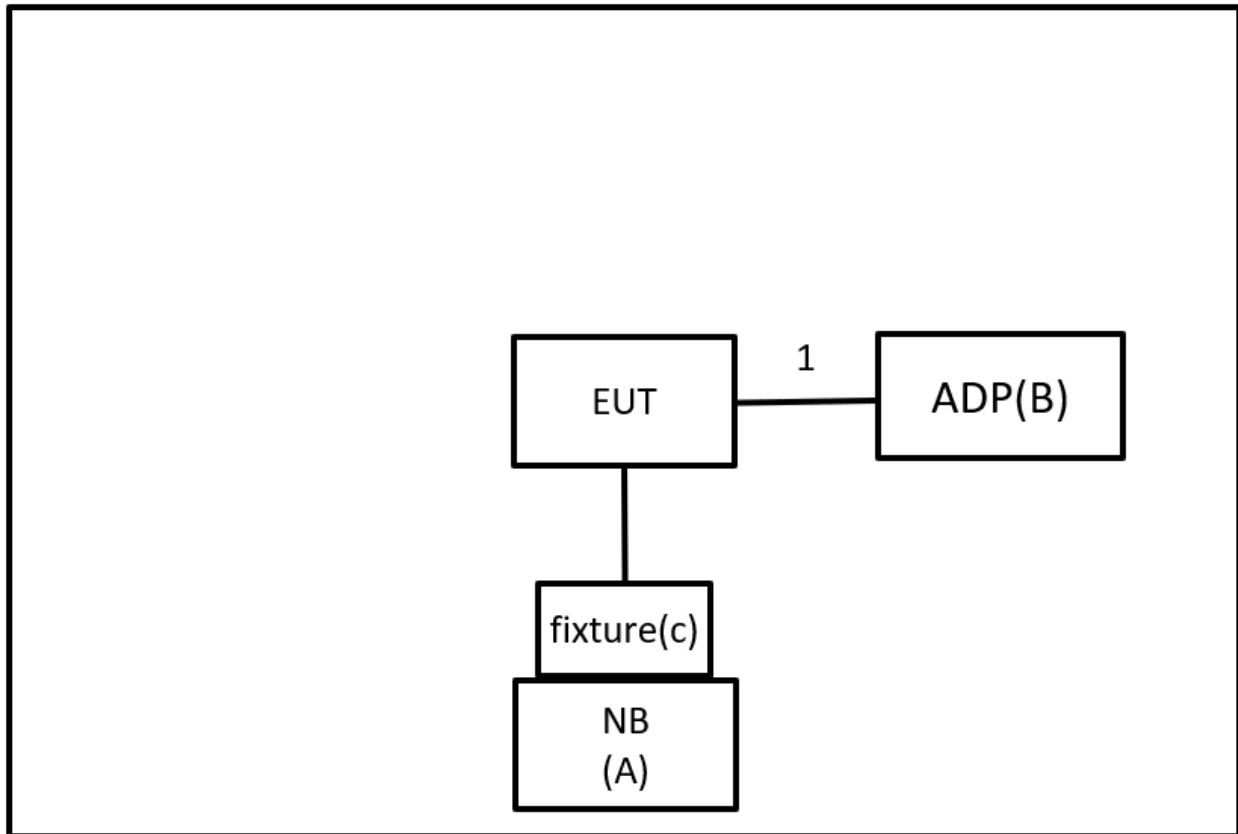

2.4 SUPPORT UNITS

AC power line conducted emissions

Item	Equipment	Brand	Model No.	Series No.	Remarks
A	Adapter	iBRIDGE	IBC005	N/A	Furnished by test lab.
B	NB	HP	240 G5	N/A	Furnished by test lab.

Item	Shielded	Ferrite Core	Length	Cable Type	Remarks
1	N/A	N/A	1m	USB-C Cable	Supplied by test requester

Radiated Emissions (below 1GHz)

Item	Equipment	Brand	Model No.	Series No.	Remarks
A	NB	HP	TPN-I119	N/A	Furnished by test lab.
B	Adapter	xiaomi	AD652G	N/A	Furnished by test lab.
C	Fixture	Waveshare	PL2303	N/A	Furnished by test lab.
D	Mouse	DELL	MOCZUL	CN-049TWY- PRC00-79E- 01HA	Furnished by test lab.
E	USB 3.0 HDD	WD	WD3C0010BS L-0B	WX81A88ALJU C	Furnished by test lab.

Item	Shielded	Ferrite Core	Length	Cable Type	Remarks
1	N/A	N/A	1m	USB-C Cable	Supplied by test requester
2	N/A	N/A	0.45m	USB Cable	Furnished by test lab.
3	N/A	N/A	0.1m	USB to USB-C Cable	Furnished by test lab.

Radiated Emissions (above 1GHz)

Item	Equipment	Brand	Model No.	Series No.	Remarks
A	NB	Asus	B500-P45VA-0141A3230M	N/A	Furnished by test lab.
B	Adapter	iBRIDGE	IBC005	N/A	Furnished by test lab.
C	Fixture	Waveshare	PL2303	N/A	Furnished by test lab.

Item	Shielded	Ferrite Core	Length	Cable Type	Remarks
1	N/A	N/A	1m	USB-C Cable	Supplied by test requester

3 AC POWER LINE CONDUCTED EMISSIONS TEST

3.1 LIMIT

Frequency (MHz)	Limit (dB μ V)	
	Quasi-peak	Average
0.15 - 0.5	66 - 56 *	56 - 46 *
0.50 - 5.0	56	46
5.0 - 30.0	60	50

NOTE:

- (1) The tighter limit applies at the band edges.
- (2) The limit of " * " marked band means the limitation decreases linearly with the logarithm of the frequency in the range.
- (3) The test result calculated as following:
 Measurement Value = Reading Level + Correct Factor
 Correct Factor = Insertion Loss + Cable Loss + Attenuator Factor (if use)
 Margin Level = Measurement Value – Limit Value
 Calculation example:

Reading Level		Correct Factor		Measurement Value
38.22	+	3.45	=	41.67

Measurement Value		Limit Value		Margin Level
41.67	-	60	=	-18.33

The following table is the setting of the receiver.

Receiver Parameter	Setting
Attenuation	10 dB
Start Frequency	0.15 MHz
Stop Frequency	30 MHz
IF Bandwidth	9 KHz

3.2 TEST PROCEDURE

- a. The EUT was placed 0.8 m above the horizontal ground plane with the EUT being connected to the power mains through a line impedance stabilization network (LISN).
 All other support equipment were powered from an additional LISN(s).
 The LISN provides 50 Ohm/50uH of impedance for the measuring instrument.
- b. Interconnecting cables that hang closer than 40 cm to the ground plane shall be folded back and forth in the center forming a bundle to keep the cable above 40 cm.
- c. Excess I/O cables that are not connected to a peripheral shall be bundled in the center.
 The end of the cable will be terminated, using the correct terminating impedance.
 The overall length shall not exceed 1 m.
- d. The LISN is spaced at least 80 cm from the nearest part of the EUT chassis.
- e. For the actual test configuration, please refer to the related Item – EUT TEST PHOTO.

NOTE:

- (1) In the results, each reading is marked as Peak, QP or AVG per the detector used.
 BW=9 kHz (6 dB Bandwidth)
- (2) All readings are Peak unless otherwise stated QP or AVG in column of Note. Both the QP and the AVG readings must be less than the limit for compliance.

3.3 DEVIATION FROM TEST STANDARD

No deviation.

3.4 TEST SETUP

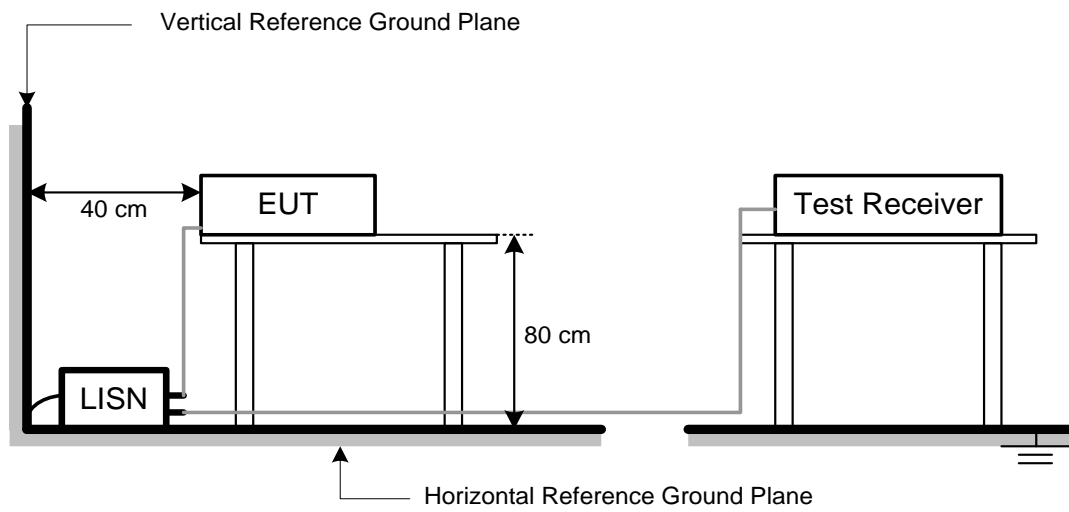

3.5 TEST RESULT

Please refer to the APPENDIX A.

4 RADIATED EMISSIONS TEST

4.1 LIMIT

In case the emission fall within the restricted band specified on 15.205, then the 15.209 limit in the table below has to be followed.

LIMITS OF RADIATED EMISSIONS MEASUREMENT (9 kHz to 1000 MHz)

Frequency (MHz)	Field Strength (microvolts/meter)	Measurement Distance (meters)
0.009~0.490	2400/F(KHz)	300
0.490~1.705	24000/F(KHz)	30
1.705~30.0	30	30
30~88	100	3
88~216	150	3
216~960	200	3
960~1000	500	3

LIMITS OF RADIATED EMISSIONS MEASUREMENT (Above 1000 MHz)

Frequency (MHz)	Radiated Emissions (dBuV/m)		Measurement Distance (meters)
	Peak	Average	
Above 1000	74	54	3

NOTE:

- (1) The limit for radiated test was performed according to FCC CFR Title 47, Part 15, Subpart C.
- (2) The tighter limit applies at the band edges.
- (3) Emission level (dBuV/m)=20log Emission level (uV/m).
- (4) The test result calculated as following:

Measurement Value = Reading Level + Correct Factor

Correct Factor = Antenna Factor + Cable Loss - Amplifier Gain(if use)

Margin Level = Measurement Value - Limit Value

Calculation example:

Reading Level		Correct Factor		Measurement Value
19.11	+	2.11	=	21.22

Measurement Value		Limit Value		Margin Level
21.22	-	54	=	-32.78

Spectrum Parameter	Setting
Attenuation	Auto
Start Frequency	1000 MHz
Stop Frequency	10th carrier harmonic
RBW / VBW (Emission in restricted band)	1MHz / 3MHz for Peak, 1MHz / 1/T for Average

Spectrum Parameter	Setting
Attenuation	Auto
Start ~ Stop Frequency	9KHz~90KHz for PK/AVG detector
Start ~ Stop Frequency	90KHz~110KHz for QP detector
Start ~ Stop Frequency	110KHz~490KHz for PK/AVG detector
Start ~ Stop Frequency	490KHz~30MHz for QP detector
Start ~ Stop Frequency	30MHz~1000MHz for QP detector

4.2 TEST PROCEDURE

- a. The measuring distance of 3 m shall be used for measurements. The EUT was placed on the top of a rotating table 0.8 meter above the ground at a 3 meter semi-anechoic chamber. The table was rotated 360 degrees to determine the position of the highest radiation.(below 1GHz)
- b. The measuring distance of 3 m shall be used for measurements. The EUT was placed on the top of a rotating table 1.5 meter above the ground at a 3 meter semi-anechoic chamber. The table was rotated 360 degrees to determine the position of the highest radiation.(above 1GHz)
- c. The height of the equipment or of the substitution antenna shall be 0.8 m or 1.5 m, the height of the test antenna shall vary between 1 m to 4 m. Both horizontal and vertical polarizations of the antenna are set to make the measurement.
- d. For each suspected emission, the EUT was arranged to its worst case and then the antenna was tuned to heights find the maximum reading (used Bore sight function).
- e. The receiver system was set to peak and average detect function and specified bandwidth with maximum hold mode when the test frequency is above 1GHz.
- f. The initial step in collecting radiated emission data is a receiver peak detector mode pre-scanning the measurement frequency range. Significant peaks are then marked and then Quasi Peak detector mode re-measured.
- g. All readings are Peak unless otherwise stated QP in column of Note. Peak denotes that the Peak reading compliance with the QP Limits and then QP Mode measurement didn't perform. (below 1GHz)
- h. All readings are Peak Mode value unless otherwise stated AVG in column of Note. If the Peak Mode Measured value compliance with the Peak Limits and lower than AVG Limits, the EUT shall be deemed to meet both Peak & AVG Limits and then only Peak Mode was measured, but AVG Mode didn't perform. (above 1GHz)
- i. For the actual test configuration, please refer to the related Item – EUT TEST PHOTO.

4.3 DEVIATION FROM TEST STANDARD

No deviation.

4.4 TEST SETUP

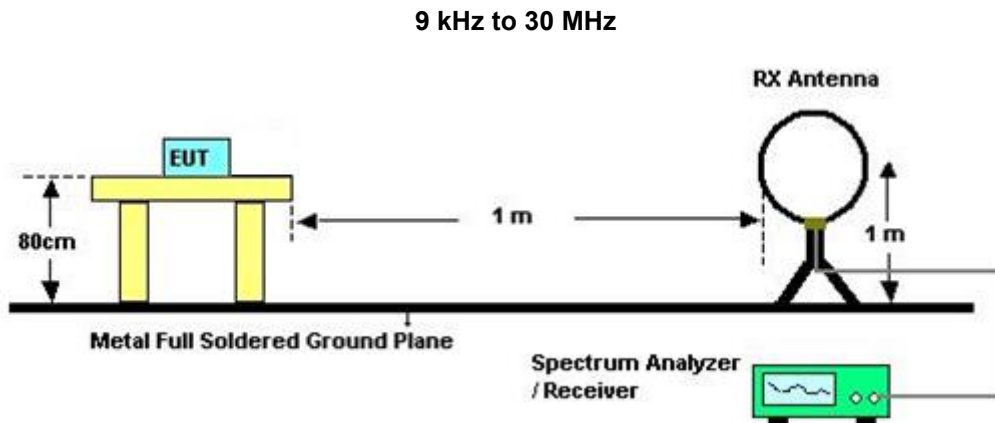

30 MHz to 1 GHz

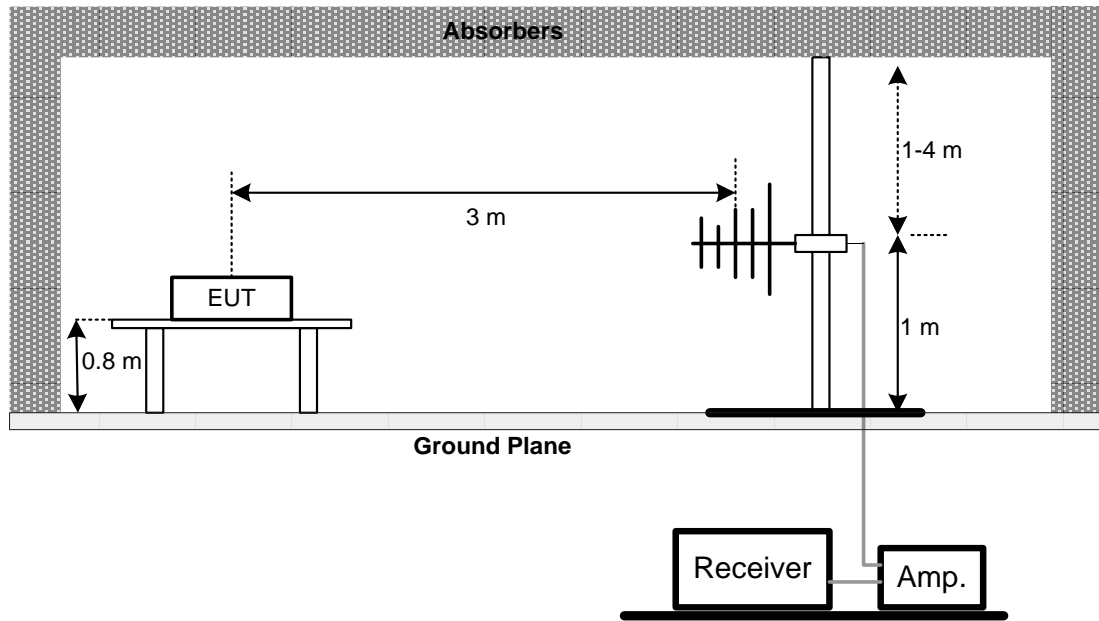

Above 1 GHz

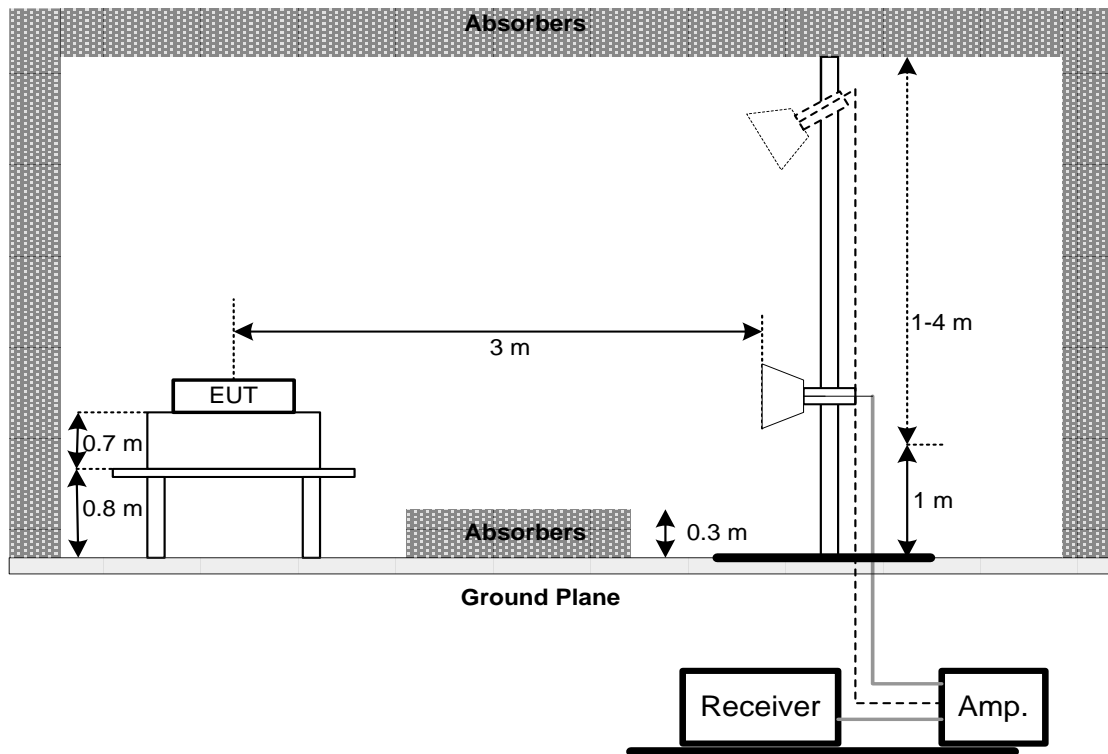

4.5 EUT OPERATING CONDITIONS

The EUT was programmed to be in continuously transmitting mode.

4.6 TEST RESULT – BELOW 30 MHZ

There were no emissions found below 30 MHz within 20 dB of the limit.

4.7 TEST RESULT – 30 MHZ TO 1 GHZ

Please refer to the APPENDIX B.

4.8 TEST RESULT – ABOVE 1 GHZ

Please refer to the APPENDIX C.

NOTE:

- (1) No limit: This is fundamental signal, the judgment is not applicable.
For fundamental signal judgment was referred to Peak output test.

5 BANDWIDTH TEST

5.1 LIMIT

FCC Part15, Subpart C (15.247)		
Section	Test Item	Limit
15.247(a)	6 dB Bandwidth	500 kHz

5.2 TEST PROCEDURE

- The EUT was directly connected to the spectrum analyzer and antenna output port as show in the block diagram below.
- Spectrum Setting: RBW= 100KHz, VBW=300KHz, Sweep time = 2.5 ms.

5.3 DEVIATION FROM TEST STANDARD

No deviation.

5.4 TEST SETUP

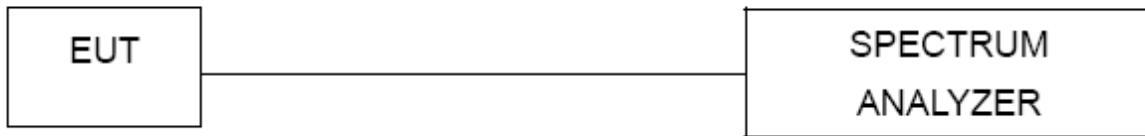

5.5 EUT OPERATING CONDITIONS

The EUT was programmed to be in continuously transmitting mode.

5.6 TEST RESULT

Please refer to the APPENDIX D.

6 OUTPUT POWER TEST**6.1 LIMIT**

FCC Part15, Subpart C (15.247)		
Section	Test Item	Limit
15.247(b)	Maximum Output Power	1 Watt or 30dBm

6.2 TEST PROCEDURE

- a. The EUT was directly connected to the power meter and antenna output port as show in the block diagram below.
- b. The maximum peak conducted output power was performed in accordance with FCC KDB 558074 D01 15.247 Meas Guidance.
- c. Subclause 11.9.1.1 of ANSI C63.10 is applied. The maximum peak conducted output power may be measured using a broadband peak RF power meter. The power meter shall have a video bandwidth that is greater than or equal to the DTS bandwidth and shall use a fast-responding diode detector.

6.3 DEVIATION FROM TEST STANDARD

No deviation.

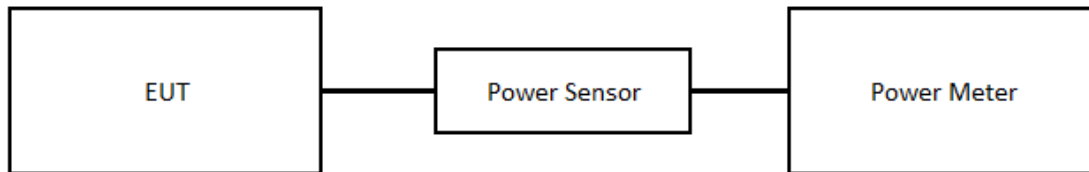
6.4 TEST SETUP**6.5 EUT OPERATING CONDITIONS**

The EUT was programmed to be in continuously transmitting mode.

6.6 TEST RESULT

Please refer to the APPENDIX E.

7 POWER SPECTRAL DENSITY

7.1 LIMIT

FCC Part15, Subpart C (15.247)		
Section	Test Item	Limit
15.247(e)	Power Spectral Density	8 dBm (in any 3 kHz)

7.2 TEST PROCEDURE

- The EUT was directly connected to the spectrum analyzer and antenna output port as show in the block diagram below.
- Spectrum Setting: RBW = 3 kHz, VBW = 10 kHz, Sweep time = Auto.

7.3 DEVIATION FROM TEST STANDARD

No deviation.

7.4 TEST SETUP

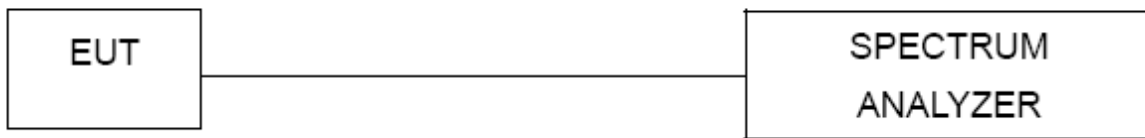

7.5 EUT OPERATING CONDITIONS

The EUT was programmed to be in continuously transmitting mode.

7.6 TEST RESULT

Please refer to the APPENDIX F.

8 ANTENNA CONDUCTED SPURIOUS EMISSIONS TEST

8.1 LIMIT

In any 100 kHz bandwidth outside the frequency band in which the spread spectrum or digitally modulated device is operating, the RF power that is produced shall be at least 20 dB below that in the 100 kHz bandwidth within the band that contains the highest level of the desired power, based on either an RF conducted or a radiated measurement, provided that the transmitter demonstrates compliance with the peak conducted power limits.

8.2 TEST PROCEDURE

- The EUT was directly connected to the spectrum analyzer and antenna output port as show in the block diagram below.
- Spectrum Setting: RBW = 100 kHz, VBW=300 kHz, Sweep time = Auto.
- Offset = antenna gain + cable loss.

8.3 DEVIATION FROM TEST STANDARD

No deviation.

8.4 TEST SETUP



8.5 EUT OPERATING CONDITIONS

The EUT was programmed to be in continuously transmitting mode.

8.6 TEST RESULT

Please refer to the APPENDIX G.

9 LIST OF MEASURING EQUIPMENTS

AC Power Line Conducted Emissions						
Item	Kind of Equipment	Manufacturer	Type No.	Serial No.	Calibrated Date	Calibrated Until
1	TWO-LINE V-NETWORK	R&S	ENV216	101051	2022/6/15	2023/6/14
2	Test Cable	EMCI	EMCRG58-BM-BM-9000	210501	2022/5/2	2023/5/1
3	EMI Test Receiver	R&S	ESR 7	101433	2021/11/24	2022/11/23
4	Measurement Software	EZ	EZ EMC (Version NB-03A1-01)	N/A	N/A	N/A

Radiated Emissions						
Item	Kind of Equipment	Manufacturer	Type No.	Serial No.	Calibrated Date	Calibrated Until
1	Preamplifier	EMCI	EMC330N	980850	2021/9/23	2022/9/22
					2022/9/19	2023/9/18
2	Preamplifier	EMCI	EMC118A45SE	980819	2022/3/8	2023/3/7
3	Preamplifier	EMCI	EMC184045SE	980882	2022/2/9	2023/2/8
4	Preamplifier	EMCI	EMC001340	980555	2022/4/6	2023/4/5
5	Test Cable	EMCI	EMC104-SM-SM-1000	220319	2022/3/15	2023/3/14
					2023/3/14	2024/3/13
6	Test Cable	EMCI	EMC104-SM-SM-3000	220322	2022/3/15	2023/3/14
					2023/3/14	2024/3/13
7	Test Cable	EMCI	EMC104-SM-SM-7000	220324	2022/3/15	2023/3/14
					2023/3/14	2024/3/13
8	EXA Signal Analyzer	keysight	N9020A	MY57120120	2022/3/7	2023/3/6
					2023/2/24	2024/2/23
9	Loop Ant	Electro-Metrics	EMCI-LPA600	274	2022/6/16	2023/6/15
10	Horn Antenna	RFSPIN	DRH18-E	211202A18EN	2022/5/18	2023/5/17
11	Horn Ant	Schwarzbeck	BBHA 9170D	1136	2022/5/18	2023/5/17
12	Log-bicon Antenna	Schwarzbeck	VULB9168	1369	2022/5/20	2023/5/19
13	6dB Attenuator	EMCI	EMCI-N-6-06	AT-N0625	2022/5/20	2023/5/19
14	Measurement Software	EZ	EZ EMC (Version NB-03A1-01)	N/A	N/A	N/A

Bandwidth						
Item	Kind of Equipment	Manufacturer	Type No.	Serial No.	Calibrated Date	Calibrated Until
1	Spectrum Analyzer	R&S	FSP 30	100854	2022/4/12	2023/4/11

Output Power						
Item	Kind of Equipment	Manufacturer	Type No.	Serial No.	Calibrated Date	Calibrated Until
1	Power Meter	Anritsu	ML2495A	1128008	2022/6/1	2023/5/31
2	Power Sensor	Anritsu	MA2411B	1126001	2022/6/1	2023/5/31

Power Spectral Density						
Item	Kind of Equipment	Manufacturer	Type No.	Serial No.	Calibrated Date	Calibrated Until
1	Spectrum Analyzer	R&S	FSP 30	100854	2022/4/12	2023/4/11

Antenna conducted Spurious Emission						
Item	Kind of Equipment	Manufacturer	Type No.	Serial No.	Calibrated Date	Calibrated Until
1	Spectrum Analyzer	R&S	FSP 30	100854	2022/4/12	2023/4/11

Remark: "N/A" denotes no model name, no serial no. or no calibration specified.
All calibration period of equipment list is one year.

10 EUT TEST PHOTO

Please refer to document Appendix No.: TP-2207T020-FCCP-1 (APPENDIX-TEST PHOTOS).

11 EUT PHOTOS

Please refer to document Appendix No.: EP-2207T020-1 (APPENDIX-EUT PHOTOS).

APPENDIX A AC POWER LINE CONDUCTED EMISSIONS

Test Mode	Normal	Tested Date	2022/8/17
Test Frequency	-	Phase	Line

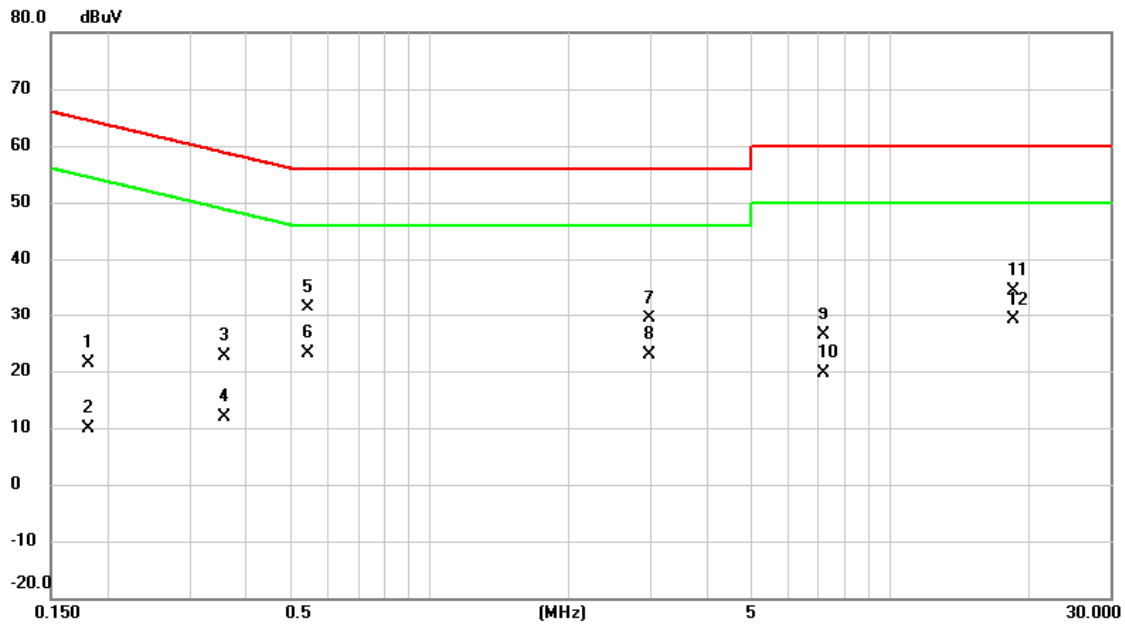

No.	Mk.	Freq. MHz	Reading Level dBuV	Correct Factor dB	Measure- ment dBuV	Limit dBuV	Margin dB	Detector	Comment
1		0.1815	11.79	9.63	21.42	64.42	-43.00	QP	
2		0.1815	0.28	9.63	9.91	54.42	-44.51	AVG	
3		0.3592	13.06	9.62	22.68	58.75	-36.07	QP	
4		0.3592	2.35	9.62	11.97	48.75	-36.78	AVG	
5		0.5460	21.70	9.62	31.32	56.00	-24.68	QP	
6		0.5460	13.41	9.62	23.03	46.00	-22.97	AVG	
7		2.9917	19.67	9.72	29.39	56.00	-26.61	QP	
8		2.9917	13.15	9.72	22.87	46.00	-23.13	AVG	
9		7.1565	16.61	9.80	26.41	60.00	-33.59	QP	
10		7.1565	9.88	9.80	19.68	50.00	-30.32	AVG	
11		18.4267	24.58	9.83	34.41	60.00	-25.59	QP	
12	*	18.4267	19.19	9.83	29.02	50.00	-20.98	AVG	

REMARKS:

- (1) Measurement Value = Reading Level + Correct Factor.
- (2) Margin Level = Measurement Value - Limit Value.

Test Mode	Normal	Tested Date	2022/8/17
Test Frequency	-	Phase	Neutral

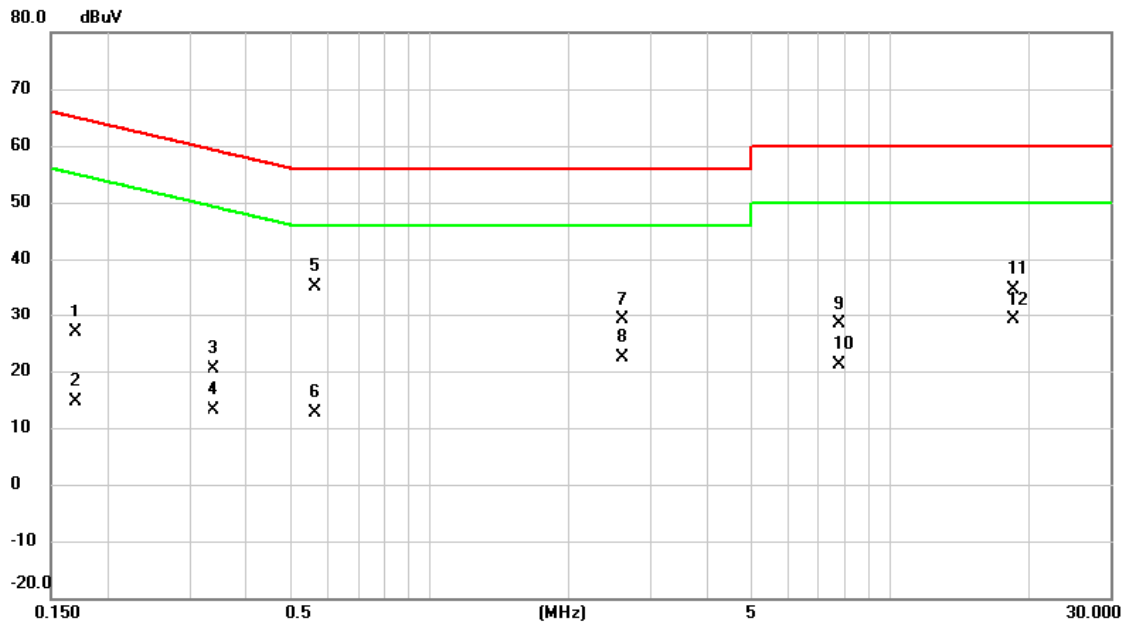

No.	Mk.	Freq. MHz	Reading Level dBuV	Correct Factor dB	Measurement dBuV	Limit dBuV	Margin dB	Detector	Comment
1		0.1703	17.29	9.63	26.92	64.95	-38.03	QP	
2		0.1703	5.10	9.63	14.73	54.95	-40.22	AVG	
3		0.3390	10.80	9.62	20.42	59.23	-38.81	QP	
4		0.3390	3.50	9.62	13.12	49.23	-36.11	AVG	
5	*	0.5640	25.51	9.62	35.13	56.00	-20.87	QP	
6		0.5640	3.08	9.62	12.70	46.00	-33.30	AVG	
7		2.6137	19.42	9.71	29.13	56.00	-26.87	QP	
8		2.6137	12.78	9.71	22.49	46.00	-23.51	AVG	
9		7.7775	18.53	9.83	28.36	60.00	-31.64	QP	
10		7.7775	11.20	9.83	21.03	50.00	-28.97	AVG	
11		18.5168	24.57	9.94	34.51	60.00	-25.49	QP	
12		18.5168	19.09	9.94	29.03	50.00	-20.97	AVG	

REMARKS:

- (1) Measurement Value = Reading Level + Correct Factor.
- (2) Margin Level = Measurement Value - Limit Value.

Test Mode	Idle	Tested Date	2022/8/17
Test Frequency	-	Phase	Line

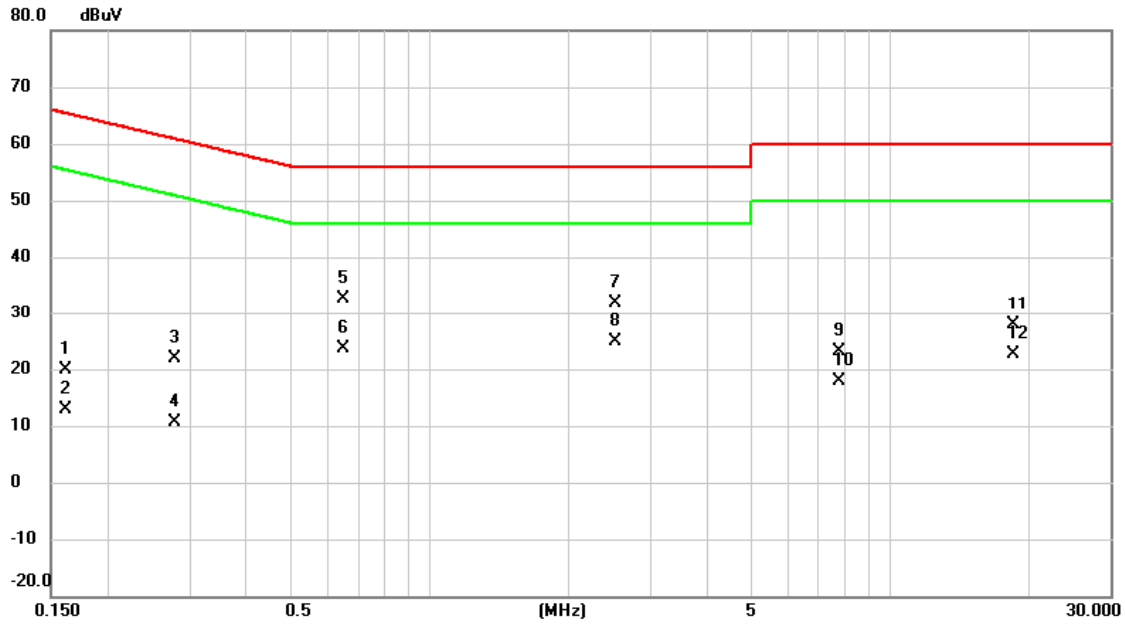

No.	Mk.	Freq. MHz	Reading Level dBuV	Correct Factor dB	Measure- ment dBuV	Limit dBuV	Margin dB	Detector	Comment
1		0.1613	10.31	9.63	19.94	65.40	-45.46	QP	
2		0.1613	3.16	9.63	12.79	55.40	-42.61	AVG	
3		0.2782	12.14	9.63	21.77	60.87	-39.10	QP	
4		0.2782	1.00	9.63	10.63	50.87	-40.24	AVG	
5		0.6495	22.98	9.63	32.61	56.00	-23.39	QP	
6		0.6495	13.98	9.63	23.61	46.00	-22.39	AVG	
7		2.5148	22.14	9.71	31.85	56.00	-24.15	QP	
8	*	2.5148	15.17	9.71	24.88	46.00	-21.12	AVG	
9		7.7730	13.30	9.81	23.11	60.00	-36.89	QP	
10		7.7730	8.10	9.81	17.91	50.00	-32.09	AVG	
11		18.4447	18.06	9.83	27.89	60.00	-32.11	QP	
12		18.4447	12.85	9.83	22.68	50.00	-27.32	AVG	

REMARKS:

- (1) Measurement Value = Reading Level + Correct Factor.
- (2) Margin Level = Measurement Value - Limit Value.

Test Mode	Idle	Tested Date	2022/8/17
Test Frequency	-	Phase	Neutral

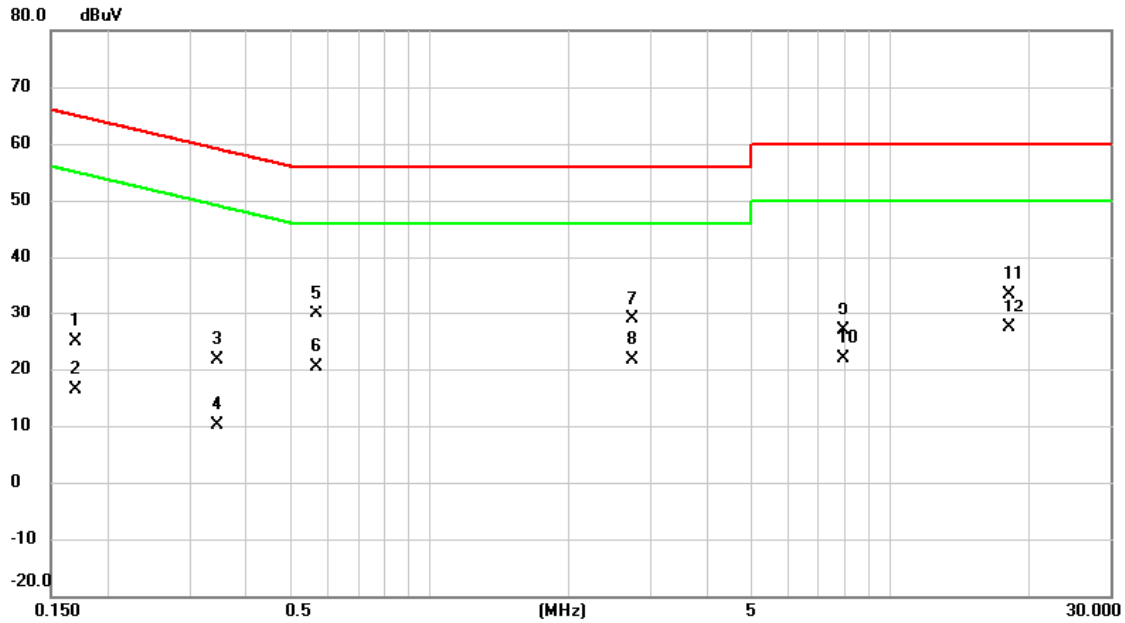

No.	Mk.	Freq. MHz	Reading Level dBuV	Correct Factor dB	Measurement dBuV	Limit dBuV	Margin dB	Detector	Comment
1		0.1702	15.37	9.63	25.00	64.95	-39.95	QP	
2		0.1702	6.75	9.63	16.38	54.95	-38.57	AVG	
3		0.3457	12.10	9.62	21.72	59.07	-37.35	QP	
4		0.3457	0.49	9.62	10.11	49.07	-38.96	AVG	
5		0.5662	20.23	9.62	29.85	56.00	-26.15	QP	
6		0.5662	10.88	9.62	20.50	46.00	-25.50	AVG	
7		2.7532	19.20	9.71	28.91	56.00	-27.09	QP	
8		2.7532	12.02	9.71	21.73	46.00	-24.27	AVG	
9		7.9057	16.99	9.83	26.82	60.00	-33.18	QP	
10		7.9057	12.15	9.83	21.98	50.00	-28.02	AVG	
11		18.1567	23.37	9.92	33.29	60.00	-26.71	QP	
12	*	18.1567	17.52	9.92	27.44	50.00	-22.56	AVG	

REMARKS:

- (1) Measurement Value = Reading Level + Correct Factor.
- (2) Margin Level = Measurement Value - Limit Value.

APPENDIX B RADIATED EMISSIONS - 30 MHZ TO 1 GHZ

Test Mode	IEEE 802.11b	Test Date	2023/1/19
Test Frequency	2437MHz	Polarization	Vertical
Temp	23°C	Hum.	59%

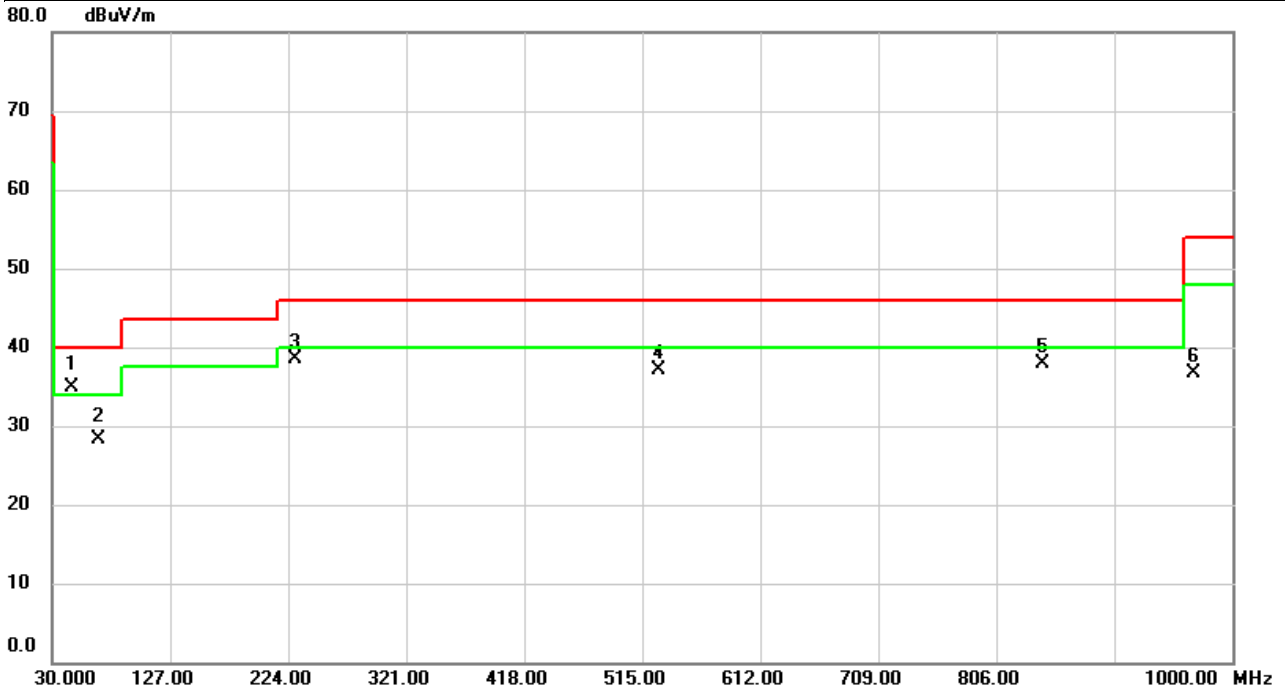

No.	Mk.	Freq.	Reading Level	Correct Factor	Measurement	Limit	Over	Detector	Comment
		MHz	dBuV	dB	dBuV/m	dBuV/m	dB		
1	*	45.6817	46.21	-11.27	34.94	40.00	-5.06	QP	
2		68.3473	41.96	-13.70	28.26	40.00	-11.74	QP	
3		229.9817	53.04	-14.59	38.45	46.00	-7.55	peak	
4		528.7417	43.16	-5.99	37.17	46.00	-8.83	peak	
5		844.3797	38.46	-0.50	37.96	46.00	-8.04	peak	
6		968.1517	35.69	1.01	36.70	54.00	-17.30	peak	

REMARKS:

- (1) Measurement Value = Reading Level + Correct Factor.
- (2) Margin Level = Measurement Value - Limit Value.

Test Mode	IEEE 802.11b	Test Date	2023/1/19
Test Frequency	2437MHz	Polarization	Horizontal
Temp	23°C	Hum.	59%

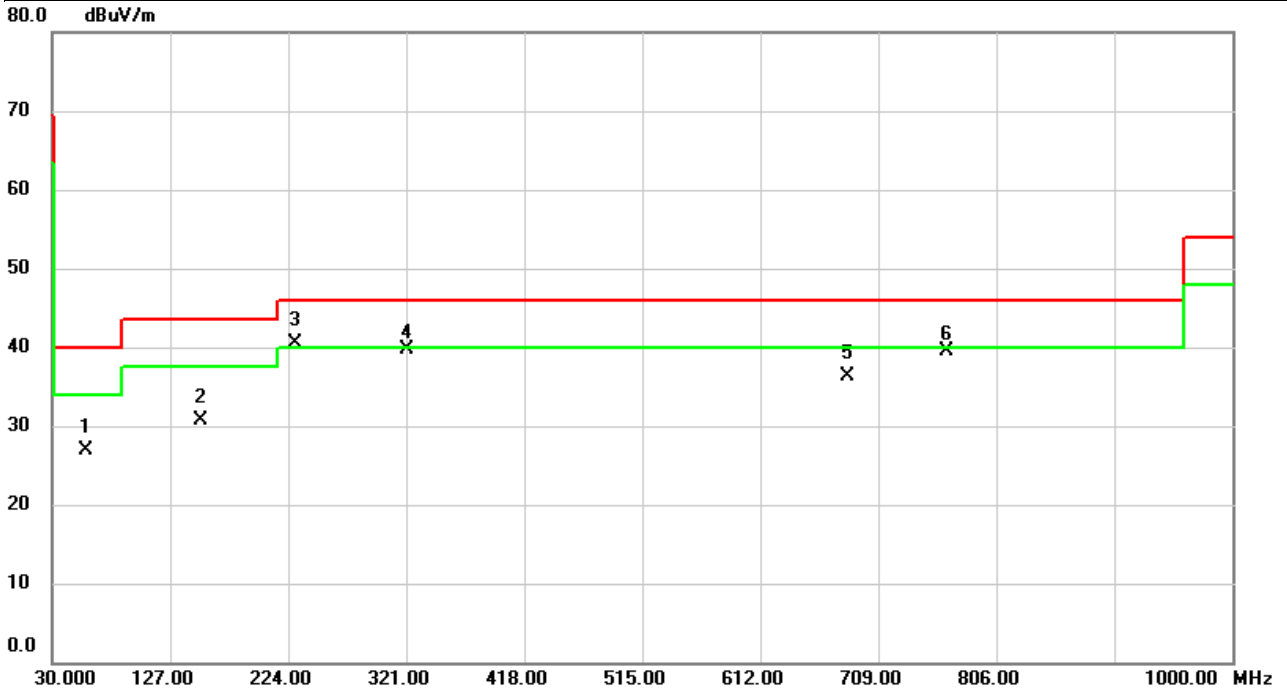

No.	Mk.	Freq. MHz	Reading Level dBuV	Correct Factor dB	Measure- ment dBuV/m	Limit dBuV/m	Over dB	Detector	Comment
1		57.6450	38.72	-11.79	26.93	40.00	-13.07	QP	
2		151.7673	42.53	-11.80	30.73	43.50	-12.77	QP	
3	*	230.2403	55.01	-14.56	40.45	46.00	-5.55	QP	
4		321.2910	50.63	-11.00	39.63	46.00	-6.37	peak	
5		683.3597	39.39	-3.11	36.28	46.00	-9.72	QP	
6		764.8073	40.86	-1.41	39.45	46.00	-6.55	peak	

REMARKS:

- (1) Measurement Value = Reading Level + Correct Factor.
- (2) Margin Level = Measurement Value - Limit Value.

APPENDIX C RADIATED EMISSIONS - ABOVE 1 GHZ

Test Mode	IEEE 802.11b	Test Date	2022/9/8
Test Frequency	2412MHz	Polarization	Horizontal
Temp	26°C	Hum.	60%

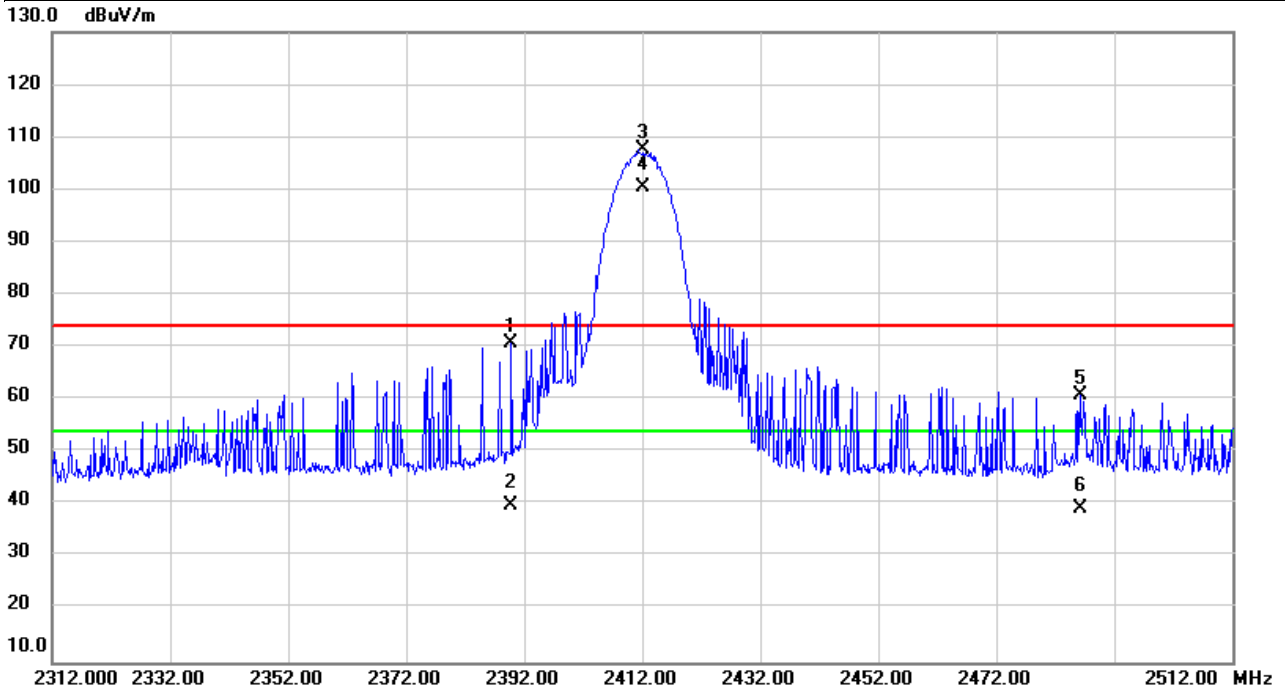

No.	Mk.	Freq. MHz	Reading Level dBuV	Correct Factor dB	Measure- ment dBuV/m	Limit dBuV/m	Over dB	Detector	Comment
1		2389.860	76.42	-5.77	70.65	74.00	-3.35	peak	
2		2389.860	45.71	-5.77	39.94	54.00	-14.06	AVG	
3	X	2412.000	113.31	-5.74	107.57	74.00	33.57	peak	NoLimit
4	*	2412.000	106.15	-5.74	100.41	54.00	46.41	AVG	NoLimit
5		2486.167	66.42	-5.63	60.79	74.00	-13.21	peak	
6		2486.167	44.97	-5.63	39.34	54.00	-14.66	AVG	

REMARKS:

- (1) Measurement Value = Reading Level + Correct Factor.
- (2) Margin Level = Measurement Value - Limit Value.

Test Mode	IEEE 802.11b	Test Date	2022/9/8
Test Frequency	2462MHz	Polarization	Horizontal
Temp	26°C	Hum.	60%

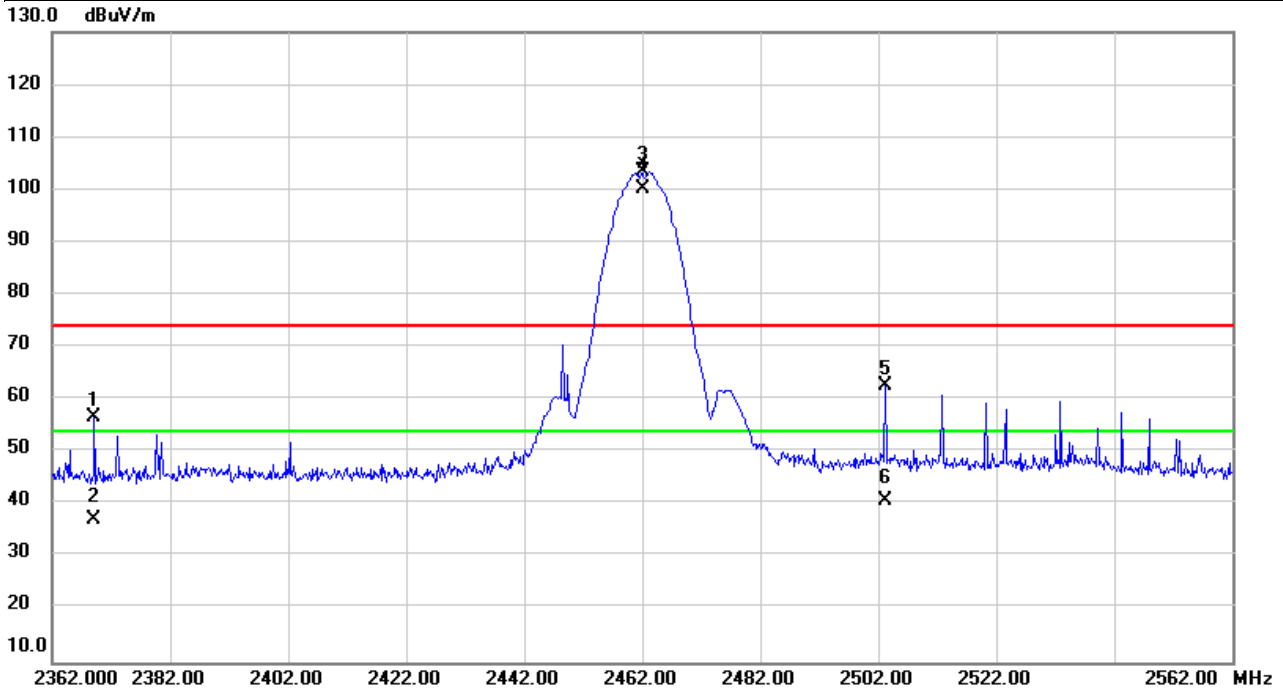

No.	Mk.	Freq. MHz	Reading Level dBuV	Correct Factor dB	Measure- ment dBuV/m	Limit dBuV/m	Over dB	Detector	Comment
1		2369.093	62.43	-5.80	56.63	74.00	-17.37	peak	
2		2369.093	42.88	-5.80	37.08	54.00	-16.92	AVG	
3	X	2462.000	109.09	-5.68	103.41	74.00	29.41	peak	NoLimit
4	*	2462.000	105.80	-5.68	100.12	54.00	46.12	AVG	NoLimit
5		2503.253	68.12	-5.61	62.51	74.00	-11.49	peak	
6		2503.253	46.47	-5.61	40.86	54.00	-13.14	AVG	

REMARKS:

- (1) Measurement Value = Reading Level + Correct Factor.
- (2) Margin Level = Measurement Value - Limit Value.

Test Mode	IEEE 802.11g	Test Date	2022/9/8
Test Frequency	2412MHz	Polarization	Horizontal
Temp	26°C	Hum.	60%

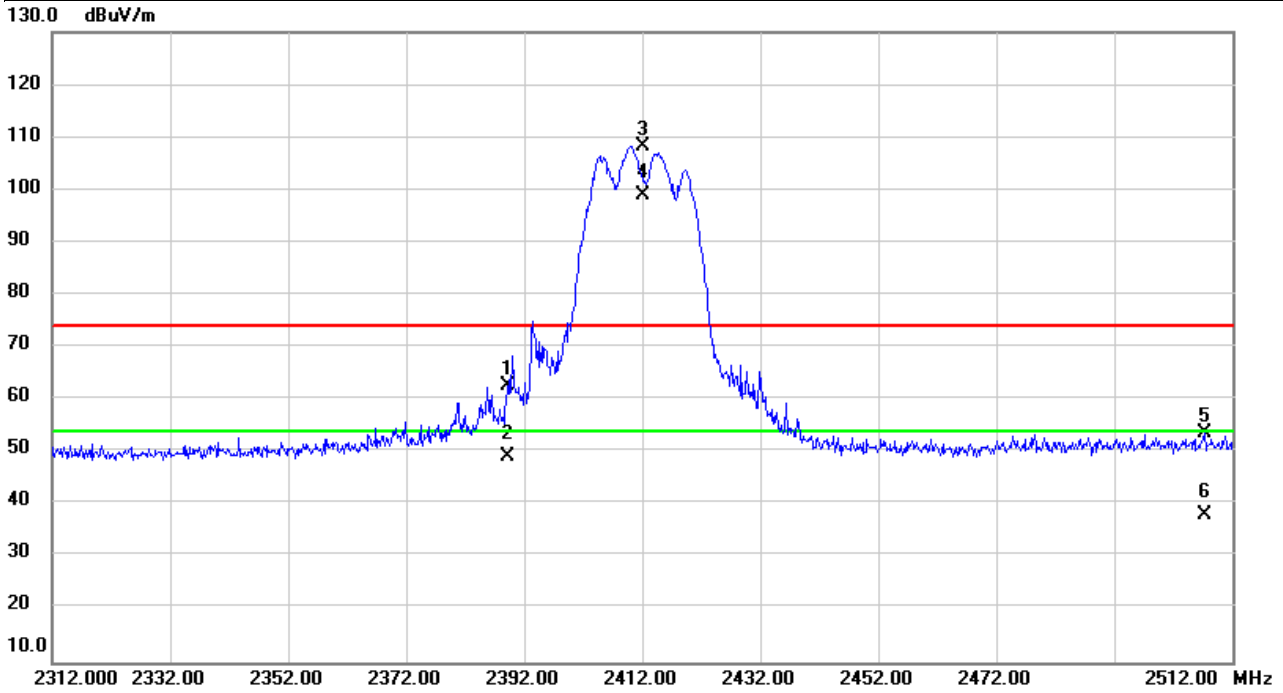

No.	Mk.	Freq. MHz	Reading Level dBuV	Correct Factor dB	Measure- ment dBuV/m	Limit dBuV/m	Over dB	Detector	Comment
1		2389.153	68.54	-5.77	62.77	74.00	-11.23	peak	
2		2389.153	54.88	-5.77	49.11	54.00	-4.89	AVG	
3	X	2412.000	114.12	-5.74	108.38	74.00	34.38	peak	NoLimit
4	*	2412.000	104.60	-5.74	98.86	54.00	44.86	AVG	NoLimit
5		2507.360	59.19	-5.58	53.61	74.00	-20.39	peak	
6		2507.360	43.72	-5.58	38.14	54.00	-15.86	AVG	

REMARKS:

- (1) Measurement Value = Reading Level + Correct Factor.
- (2) Margin Level = Measurement Value - Limit Value.

Test Mode	IEEE 802.11g	Test Date	2022/9/8
Test Frequency	2462MHz	Polarization	Horizontal
Temp	26°C	Hum.	60%

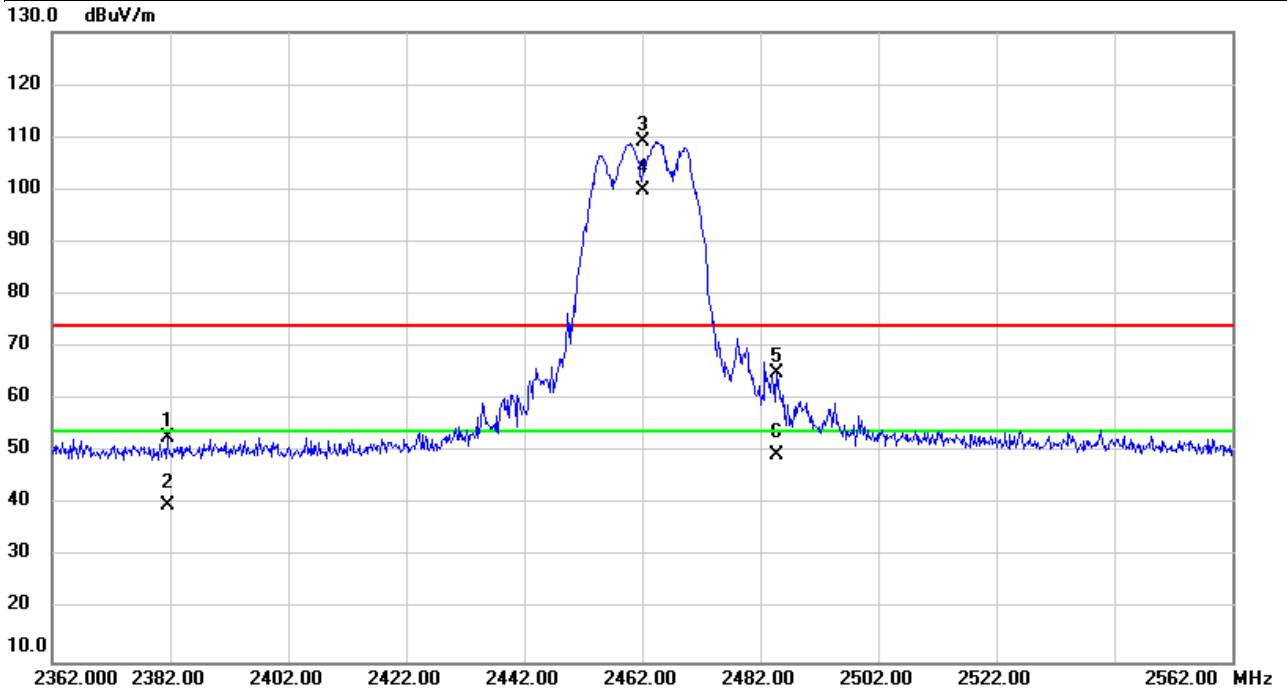

No.	Mk.	Freq.	Reading Level	Correct Factor	Measurement	Limit	Over	Detector	Comment
		MHz	dBuV	dB	dBuV/m	dBuV/m	dB		
1		2381.520	58.61	-5.78	52.83	74.00	-21.17	peak	
2		2381.520	45.62	-5.78	39.84	54.00	-14.16	AVG	
3	X	2462.000	114.77	-5.68	109.09	74.00	35.09	peak	NoLimit
4	*	2462.000	105.47	-5.68	99.79	54.00	45.79	AVG	NoLimit
5		2484.887	70.65	-5.64	65.01	74.00	-8.99	peak	
6		2484.887	55.07	-5.64	49.43	54.00	-4.57	AVG	

REMARKS:

- (1) Measurement Value = Reading Level + Correct Factor.
- (2) Margin Level = Measurement Value - Limit Value.

Test Mode	IEEE 802.11n (HT20)	Test Date	2022/9/8
Test Frequency	2412MHz	Polarization	Horizontal
Temp	26°C	Hum.	60%

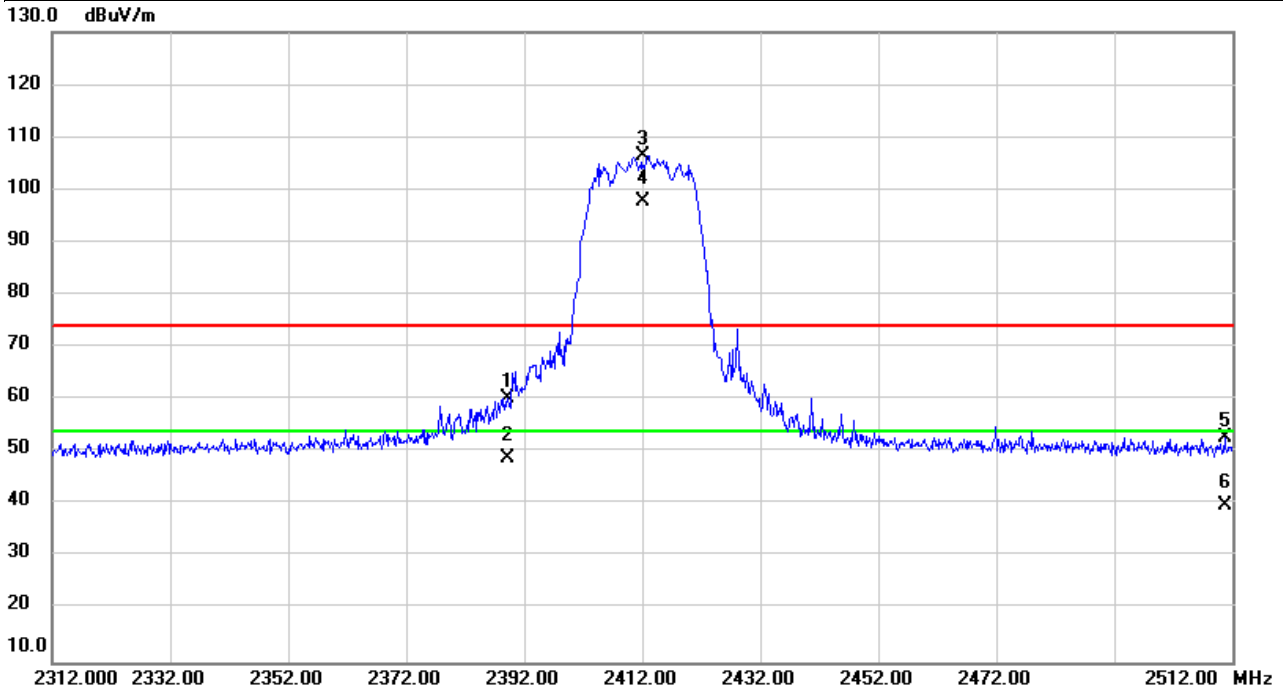

No.	Mk.	Freq. MHz	Reading Level dBuV	Correct Factor dB	Measure- ment dBuV/m	Limit dBuV/m	Over dB	Detector	Comment
1		2389.100	66.00	-5.77	60.23	74.00	-13.77	peak	
2		2389.100	54.64	-5.77	48.87	54.00	-5.13	AVG	
3	X	2412.000	112.16	-5.74	106.42	74.00	32.42	peak	NoLimit
4	*	2412.000	103.53	-5.74	97.79	54.00	43.79	AVG	NoLimit
5		2510.767	58.46	-5.57	52.89	74.00	-21.11	peak	
6		2510.767	45.41	-5.57	39.84	54.00	-14.16	AVG	

REMARKS:

- (1) Measurement Value = Reading Level + Correct Factor.
- (2) Margin Level = Measurement Value - Limit Value.

Test Mode	IEEE 802.11n (HT20)	Test Date	2022/9/8
Test Frequency	2462MHz	Polarization	Horizontal
Temp	26°C	Hum.	60%

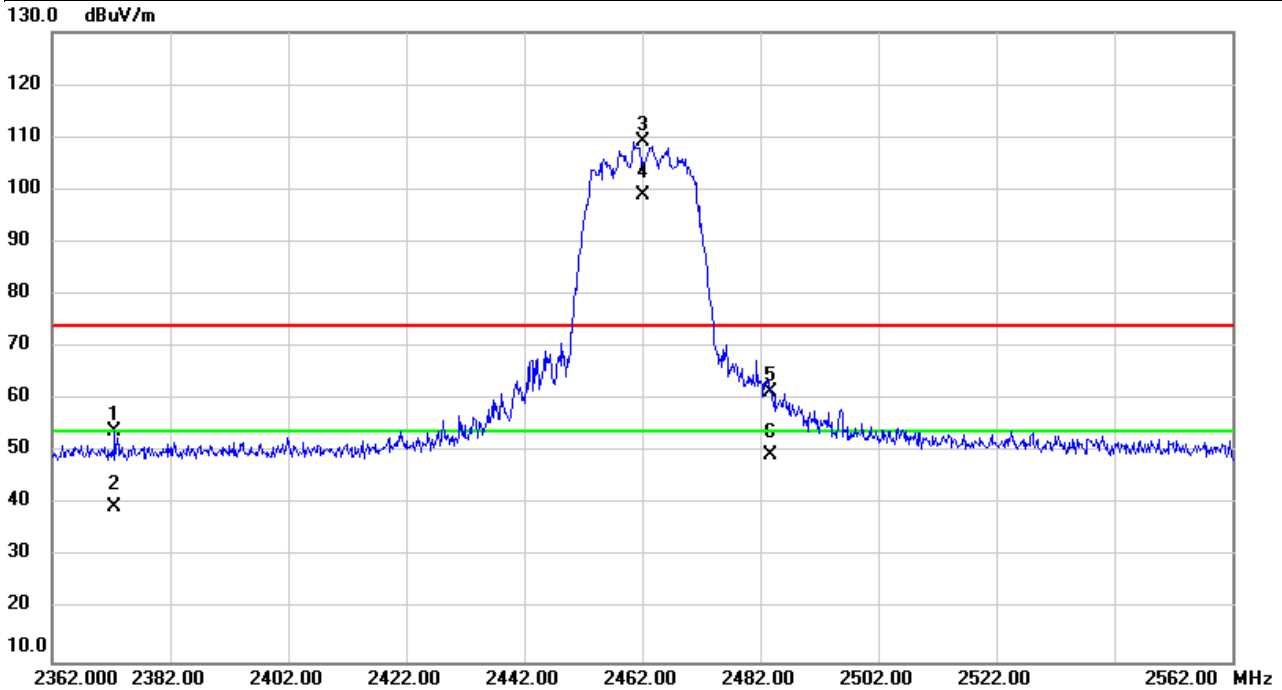

No.	Mk.	Freq. MHz	Reading Level dBuV	Correct Factor dB	Measure- ment dBuV/m	Limit dBuV/m	Over dB	Detector	Comment
1		2372.647	59.70	-5.79	53.91	74.00	-20.09	peak	
2		2372.647	45.27	-5.79	39.48	54.00	-14.52	AVG	
3	X	2462.000	114.79	-5.68	109.11	74.00	35.11	peak	NoLimit
4	*	2462.000	104.70	-5.68	99.02	54.00	45.02	AVG	NoLimit
5		2483.860	66.97	-5.65	61.32	74.00	-12.68	peak	
6		2483.860	55.23	-5.65	49.58	54.00	-4.42	AVG	

REMARKS:

- (1) Measurement Value = Reading Level + Correct Factor.
- (2) Margin Level = Measurement Value - Limit Value.

Test Mode	IEEE 802.11b	Test Date	2022/9/8
Test Frequency	2412MHz	Polarization	Vertical
Temp	26°C	Hum.	60%

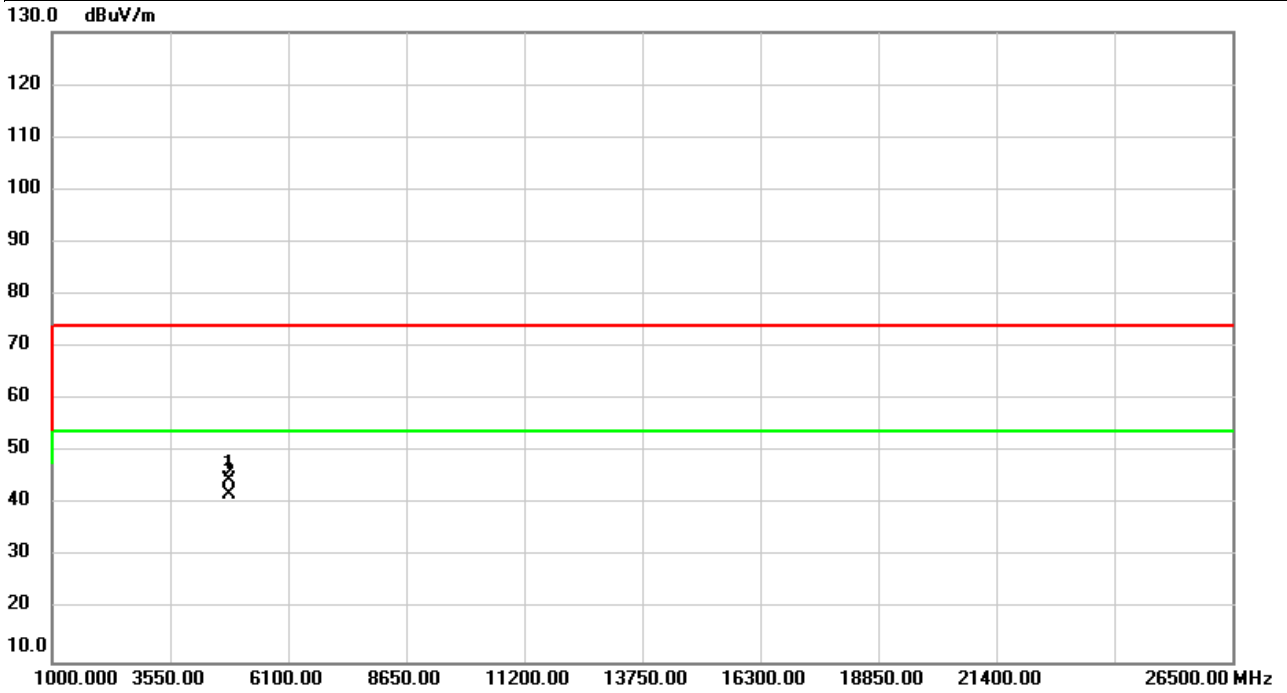

No.	Mk.	Freq. MHz	Reading Level dBuV	Correct Factor dB	Measure- ment dBuV/m	Limit dBuV/m	Over dB	Detector	Comment
1		4824.000	43.90	0.72	44.62	74.00	-29.38	peak	
2	*	4824.000	41.23	0.72	41.95	54.00	-12.05	AVG	

REMARKS:

- (1) Measurement Value = Reading Level + Correct Factor.
- (2) Margin Level = Measurement Value - Limit Value.

Test Mode	IEEE 802.11b	Test Date	2022/9/8
Test Frequency	2412MHz	Polarization	Horizontal
Temp	26°C	Hum.	60%

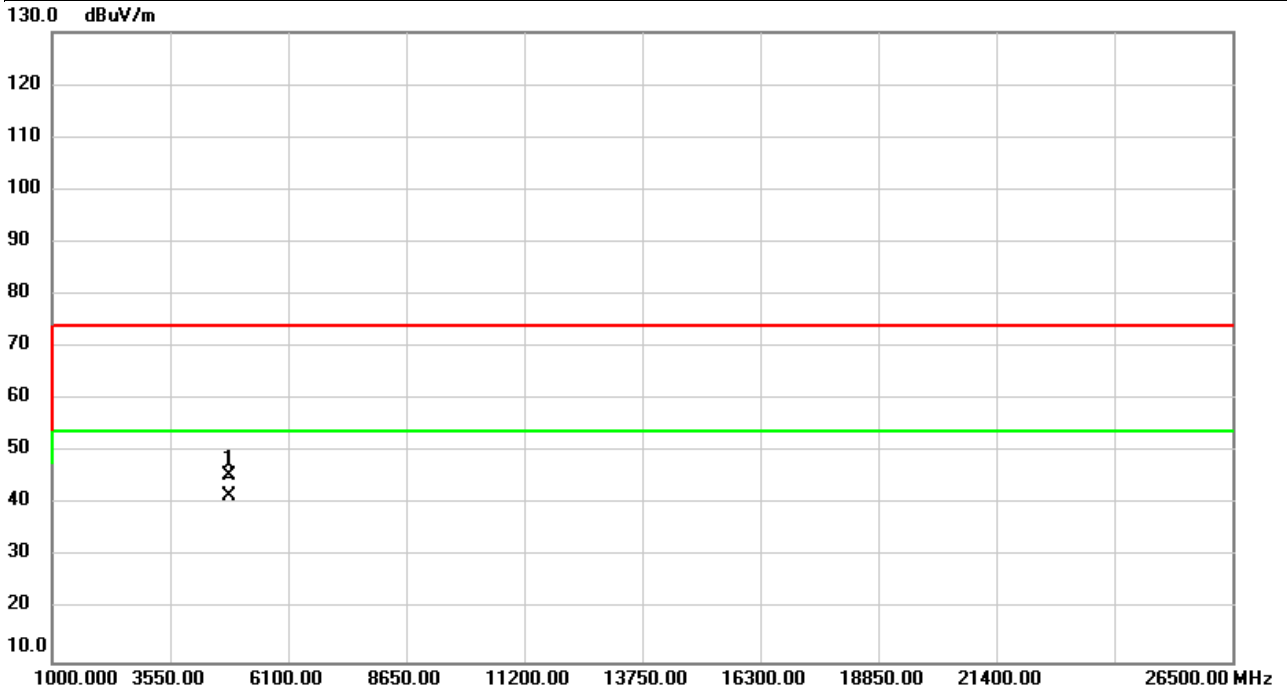

No.	Mk.	Freq.	Reading Level	Correct Factor	Measurement	Limit	Over	Detector	Comment
		MHz	dBuV	dB	dBuV/m	dBuV/m	dB		
1		4824.000	44.71	0.72	45.43	74.00	-28.57	peak	
2	*	4824.000	40.95	0.72	41.67	54.00	-12.33	AVG	

REMARKS:

- (1) Measurement Value = Reading Level + Correct Factor.
- (2) Margin Level = Measurement Value - Limit Value.

Test Mode	IEEE 802.11b	Test Date	2022/9/8
Test Frequency	2437MHz	Polarization	Vertical
Temp	26°C	Hum.	60%

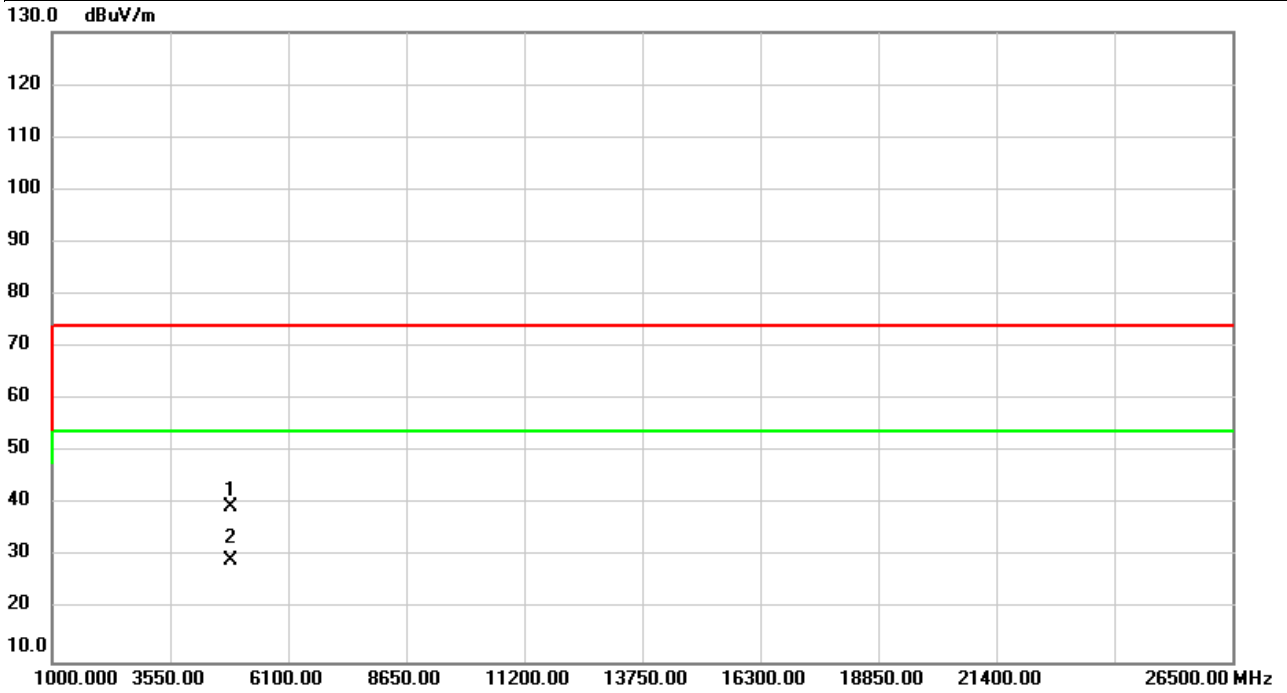

No.	Mk.	Freq. MHz	Reading Level dBuV	Correct Factor dB	Measure- ment dBuV/m	Limit dBuV/m	Over dB	Detector	Comment
1		4874.000	38.54	0.89	39.43	74.00	-34.57	peak	
2	*	4874.000	28.34	0.89	29.23	54.00	-24.77	AVG	

REMARKS:

- (1) Measurement Value = Reading Level + Correct Factor.
- (2) Margin Level = Measurement Value - Limit Value.

Test Mode	IEEE 802.11b	Test Date	2022/9/8
Test Frequency	2437MHz	Polarization	Horizontal
Temp	26°C	Hum.	60%

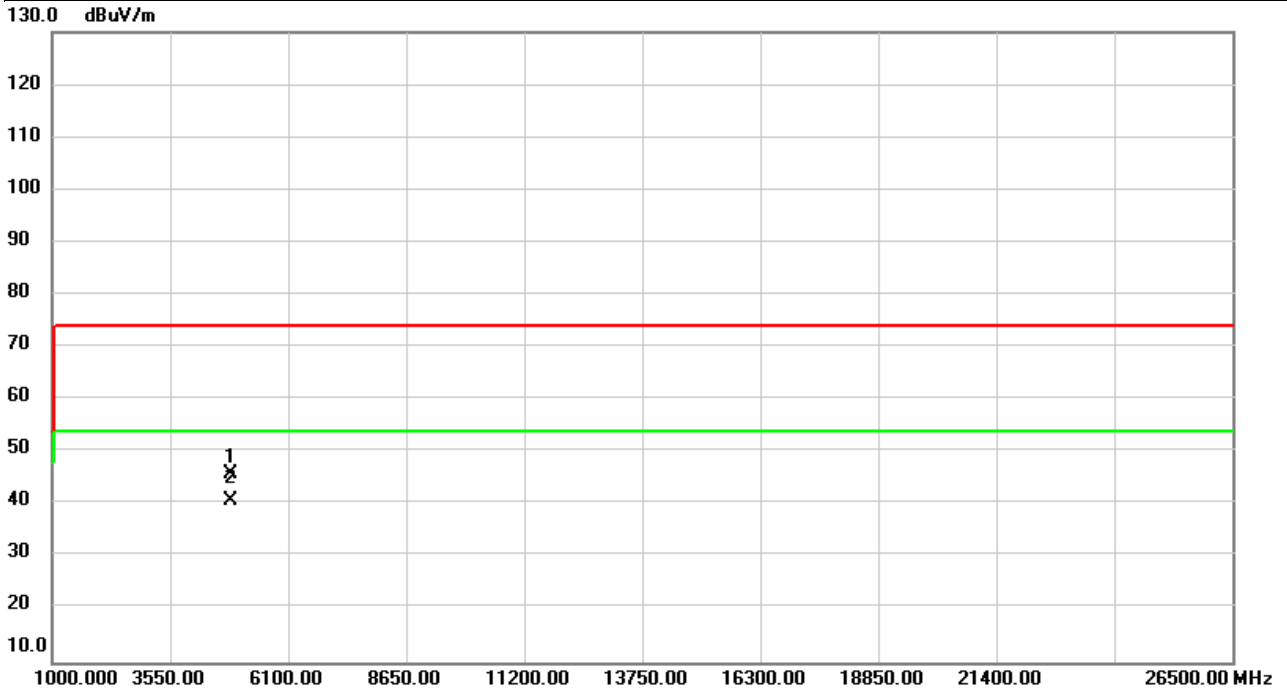

No.	Mk.	Freq. MHz	Reading Level dBuV	Correct Factor dB	Measure- ment dBuV/m	Limit dBuV/m	Over dB	Detector	Comment
1		4874.000	44.88	0.89	45.77	74.00	-28.23	peak	
2	*	4874.000	39.99	0.89	40.88	54.00	-13.12	AVG	

REMARKS:

- (1) Measurement Value = Reading Level + Correct Factor.
- (2) Margin Level = Measurement Value - Limit Value.

Test Mode	IEEE 802.11b	Test Date	2022/9/8
Test Frequency	2462MHz	Polarization	Vertical
Temp	26°C	Hum.	60%

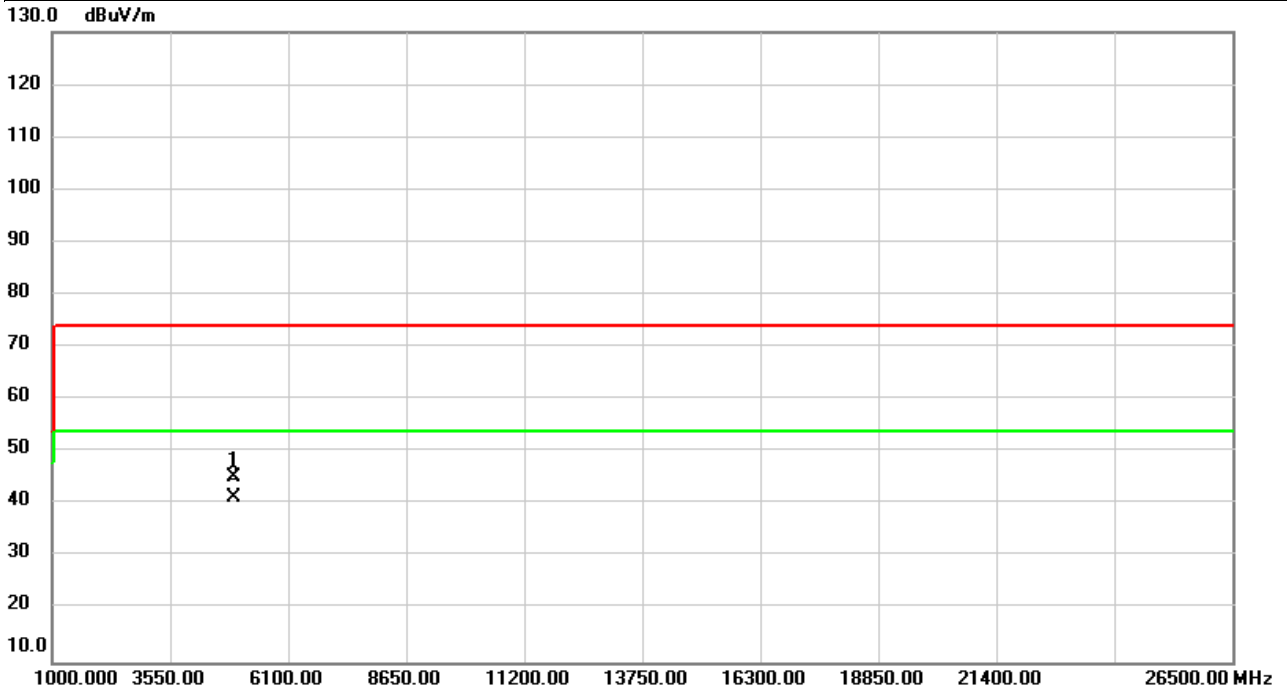

No.	Mk.	Freq.	Reading Level	Correct Factor	Measurement	Limit	Over	Detector	Comment
		MHz	dBuV	dB	dBuV/m	dBuV/m	dB		
1		4924.000	44.19	1.07	45.26	74.00	-28.74	peak	
2	*	4924.000	40.17	1.07	41.24	54.00	-12.76	AVG	

REMARKS:

- (1) Measurement Value = Reading Level + Correct Factor.
- (2) Margin Level = Measurement Value - Limit Value.

Test Mode	IEEE 802.11b	Test Date	2022/9/8
Test Frequency	2462MHz	Polarization	Horizontal
Temp	26°C	Hum.	60%

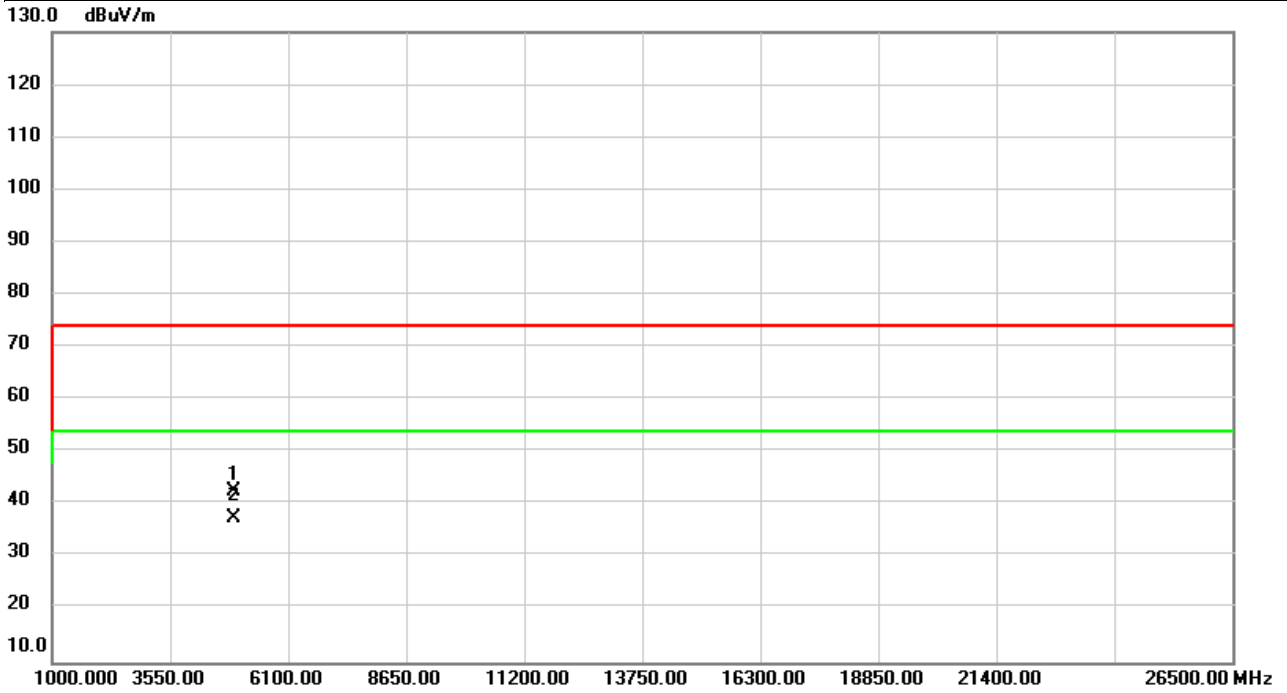

No.	Mk.	Freq. MHz	Reading Level dBuV	Correct Factor dB	Measure- ment dBuV/m	Limit dBuV/m	Over dB	Detector	Comment
1		4924.000	41.61	1.07	42.68	74.00	-31.32	peak	
2	*	4924.000	36.32	1.07	37.39	54.00	-16.61	AVG	

REMARKS:

- (1) Measurement Value = Reading Level + Correct Factor.
- (2) Margin Level = Measurement Value - Limit Value.

Test Mode	IEEE 802.11g	Test Date	2022/9/8
Test Frequency	2412MHz	Polarization	Vertical
Temp	26°C	Hum.	60%

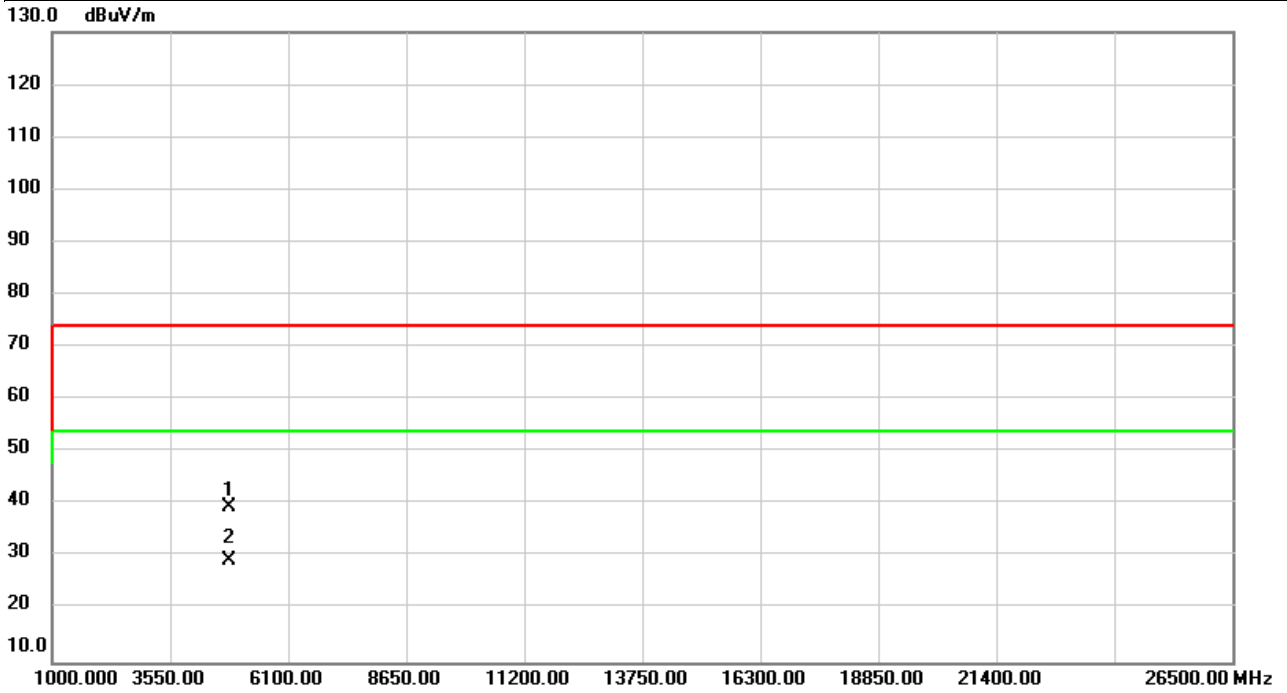

No.	Mk.	Freq. MHz	Reading Level dBuV	Correct Factor dB	Measure- ment dBuV/m	Limit dBuV/m	Over dB	Detector	Comment
1		4824.000	38.71	0.72	39.43	74.00	-34.57	peak	
2	*	4824.000	28.51	0.72	29.23	54.00	-24.77	AVG	

REMARKS:

- (1) Measurement Value = Reading Level + Correct Factor.
- (2) Margin Level = Measurement Value - Limit Value.

Test Mode	IEEE 802.11g	Test Date	2022/9/8
Test Frequency	2412MHz	Polarization	Horizontal
Temp	26°C	Hum.	60%

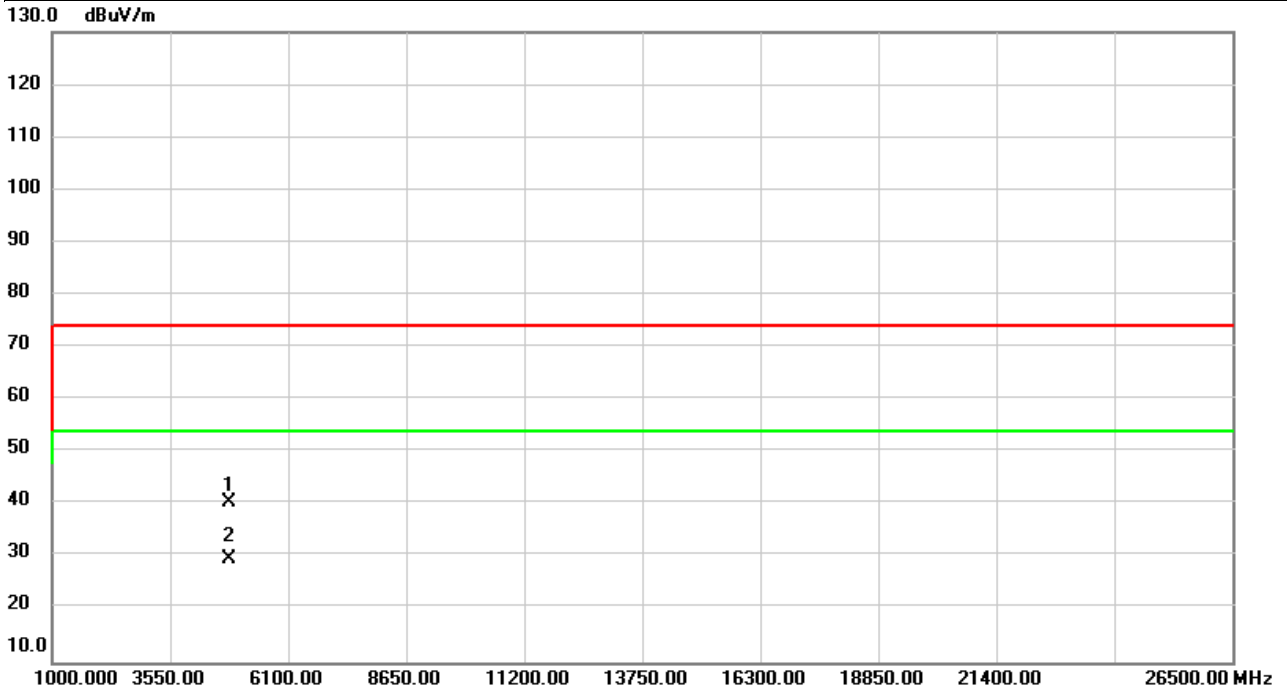

No.	Mk.	Freq. MHz	Reading Level dBuV	Correct Factor dB	Measure- ment dBuV/m	Limit dBuV/m	Over dB	Detector	Comment
1		4824.000	39.72	0.72	40.44	74.00	-33.56	peak	
2	*	4824.000	28.91	0.72	29.63	54.00	-24.37	AVG	

REMARKS:

- (1) Measurement Value = Reading Level + Correct Factor.
- (2) Margin Level = Measurement Value - Limit Value.

Test Mode	IEEE 802.11g	Test Date	2022/9/8
Test Frequency	2437MHz	Polarization	Vertical
Temp	26°C	Hum.	60%

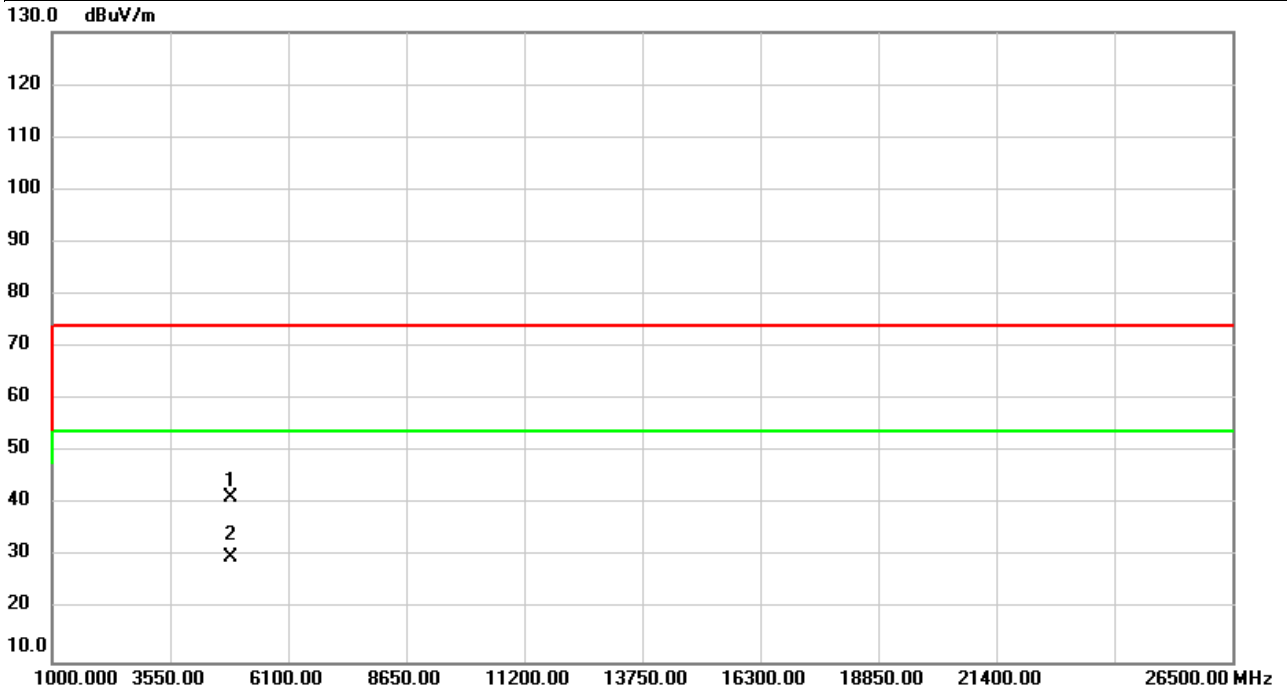

No.	Mk.	Freq. MHz	Reading Level dBuV	Correct Factor dB	Measure- ment dBuV/m	Limit dBuV/m	Over dB	Detector	Comment
1		4874.000	40.54	0.89	41.43	74.00	-32.57	peak	
2	*	4874.000	29.09	0.89	29.98	54.00	-24.02	AVG	

REMARKS:

- (1) Measurement Value = Reading Level + Correct Factor.
- (2) Margin Level = Measurement Value - Limit Value.

Test Mode	IEEE 802.11g	Test Date	2022/9/8
Test Frequency	2437MHz	Polarization	Horizontal
Temp	26°C	Hum.	60%

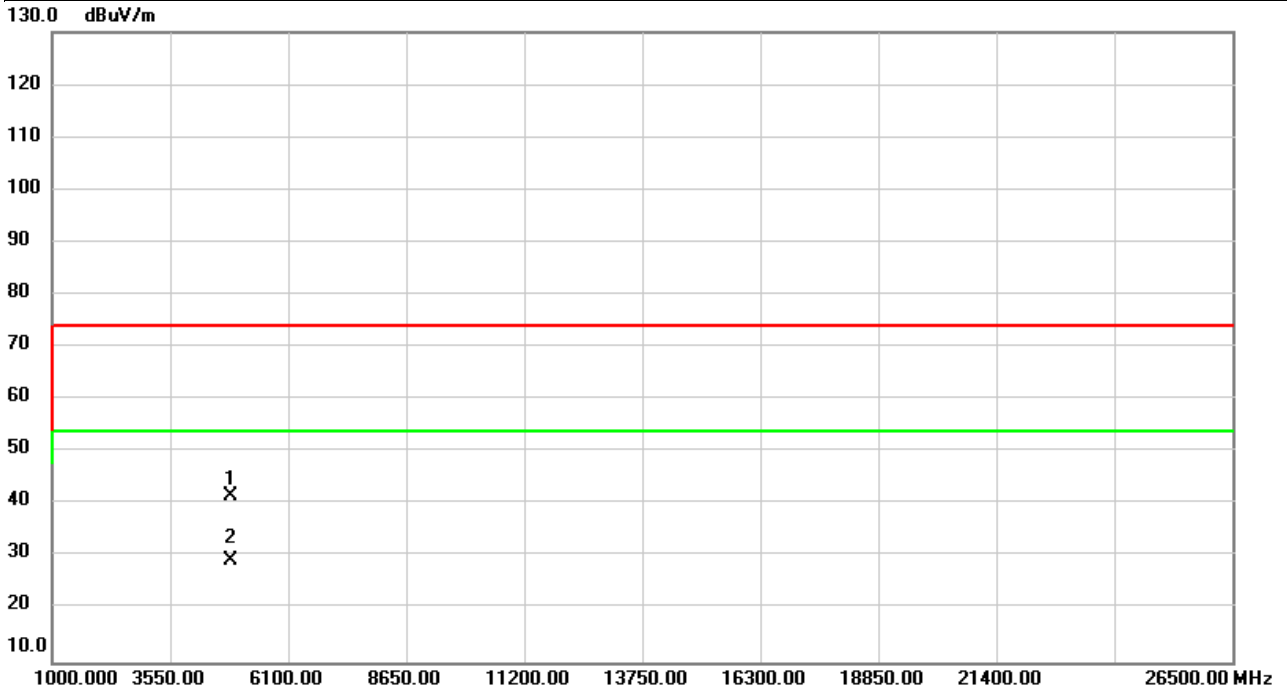

No.	Mk.	Freq. MHz	Reading Level dBuV	Correct Factor dB	Measure- ment dBuV/m	Limit dBuV/m	Over dB	Detector	Comment
1		4874.000	40.67	0.89	41.56	74.00	-32.44	peak	
2	*	4874.000	28.51	0.89	29.40	54.00	-24.60	AVG	

REMARKS:

- (1) Measurement Value = Reading Level + Correct Factor.
- (2) Margin Level = Measurement Value - Limit Value.

Test Mode	IEEE 802.11g	Test Date	2022/9/8
Test Frequency	2462MHz	Polarization	Vertical
Temp	26°C	Hum.	60%

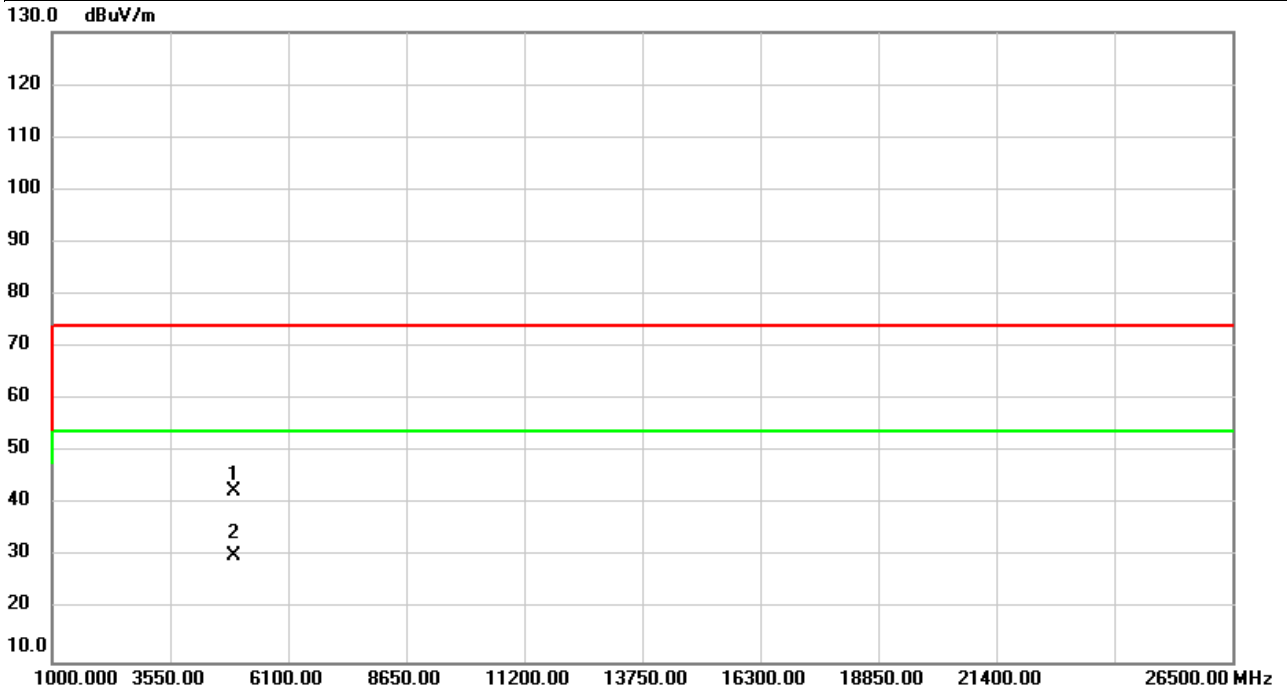

No.	Mk.	Freq. MHz	Reading Level dBuV	Correct Factor dB	Measure- ment dBuV/m	Limit dBuV/m	Over dB	Detector	Comment
1		4924.000	41.34	1.07	42.41	74.00	-31.59	peak	
2	*	4924.000	29.05	1.07	30.12	54.00	-23.88	AVG	

REMARKS:

- (1) Measurement Value = Reading Level + Correct Factor.
- (2) Margin Level = Measurement Value - Limit Value.

Test Mode	IEEE 802.11g	Test Date	2022/9/8
Test Frequency	2462MHz	Polarization	Horizontal
Temp	26°C	Hum.	60%

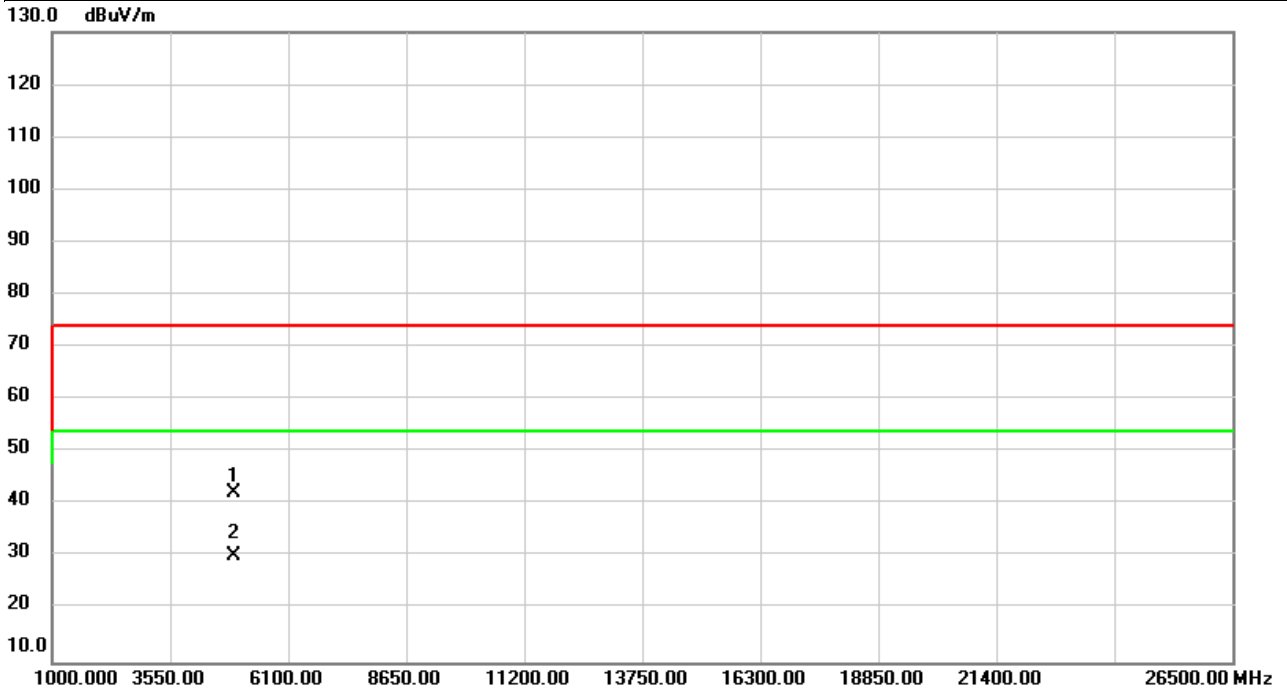

No.	Mk.	Freq. MHz	Reading Level dBuV	Correct Factor dB	Measure- ment dBuV/m	Limit dBuV/m	Over dB	Detector	Comment
1		4924.000	41.05	1.07	42.12	74.00	-31.88	peak	
2	*	4924.000	29.10	1.07	30.17	54.00	-23.83	AVG	

REMARKS:

- (1) Measurement Value = Reading Level + Correct Factor.
- (2) Margin Level = Measurement Value - Limit Value.

Test Mode	IEEE 802.11n (HT20)	Test Date	2022/9/8
Test Frequency	2412MHz	Polarization	Vertical
Temp	26°C	Hum.	60%

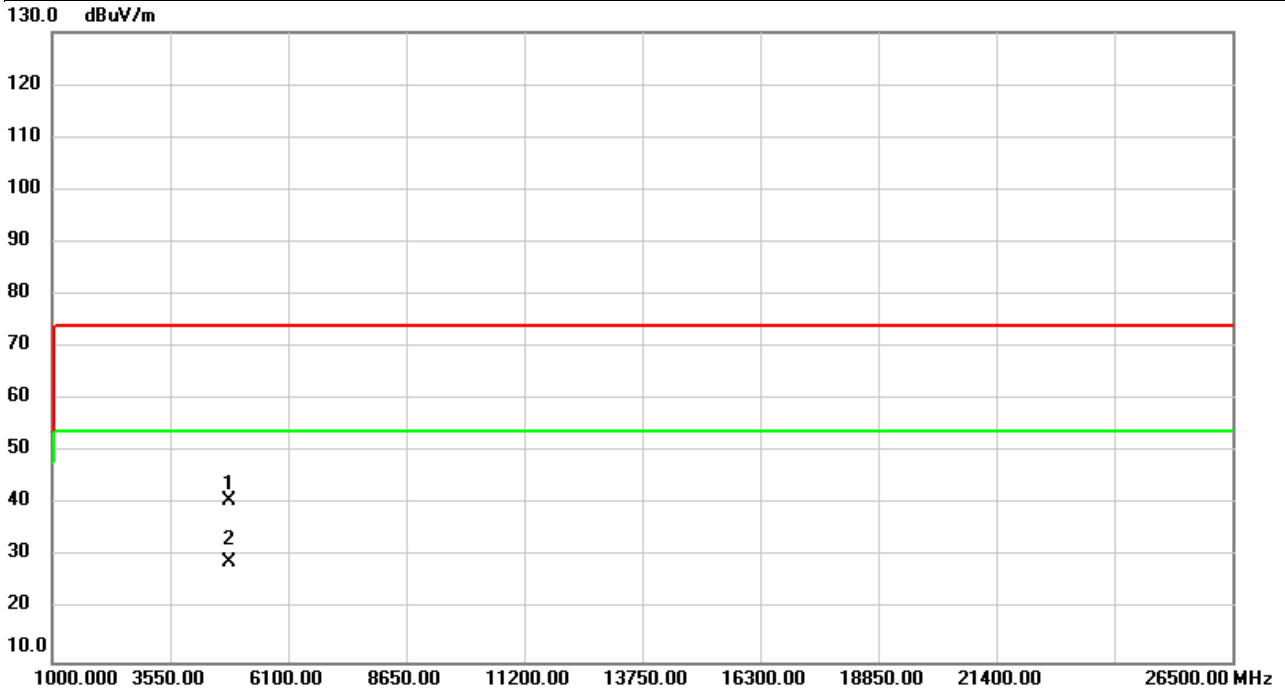

No.	Mk.	Freq. MHz	Reading Level dBuV	Correct Factor dB	Measure- ment dBuV/m	Limit dBuV/m	Over dB	Detector	Comment
1		4824.000	39.92	0.72	40.64	74.00	-33.36	peak	
2	*	4824.000	28.22	0.72	28.94	54.00	-25.06	AVG	

REMARKS:

- (1) Measurement Value = Reading Level + Correct Factor.
- (2) Margin Level = Measurement Value - Limit Value.

Test Mode	IEEE 802.11n (HT20)	Test Date	2022/9/8
Test Frequency	2412MHz	Polarization	Horizontal
Temp	26°C	Hum.	60%

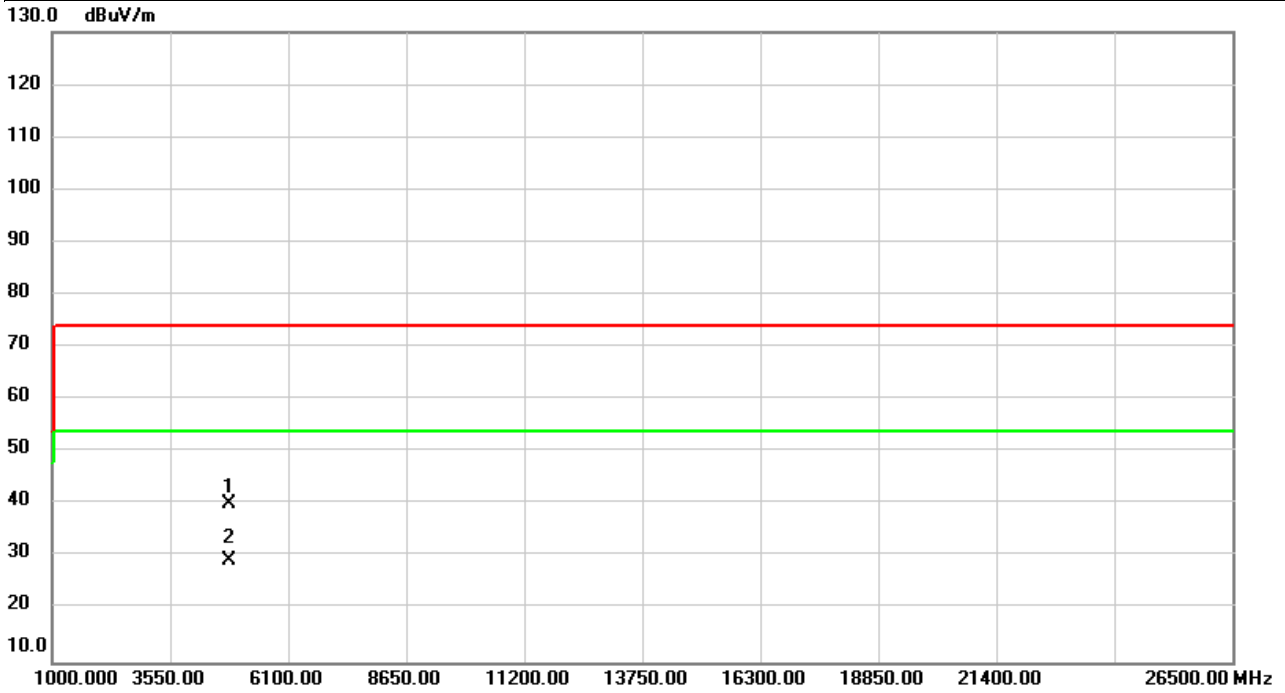

No.	Mk.	Freq. MHz	Reading Level dBuV	Correct Factor dB	Measure- ment dBuV/m	Limit dBuV/m	Over dB	Detector	Comment
1		4824.000	39.31	0.72	40.03	74.00	-33.97	peak	
2	*	4824.000	28.76	0.72	29.48	54.00	-24.52	AVG	

REMARKS:

- (1) Measurement Value = Reading Level + Correct Factor.
- (2) Margin Level = Measurement Value - Limit Value.

Test Mode	IEEE 802.11n (HT20)	Test Date	2022/9/8
Test Frequency	2437MHz	Polarization	Vertical
Temp	26°C	Hum.	60%

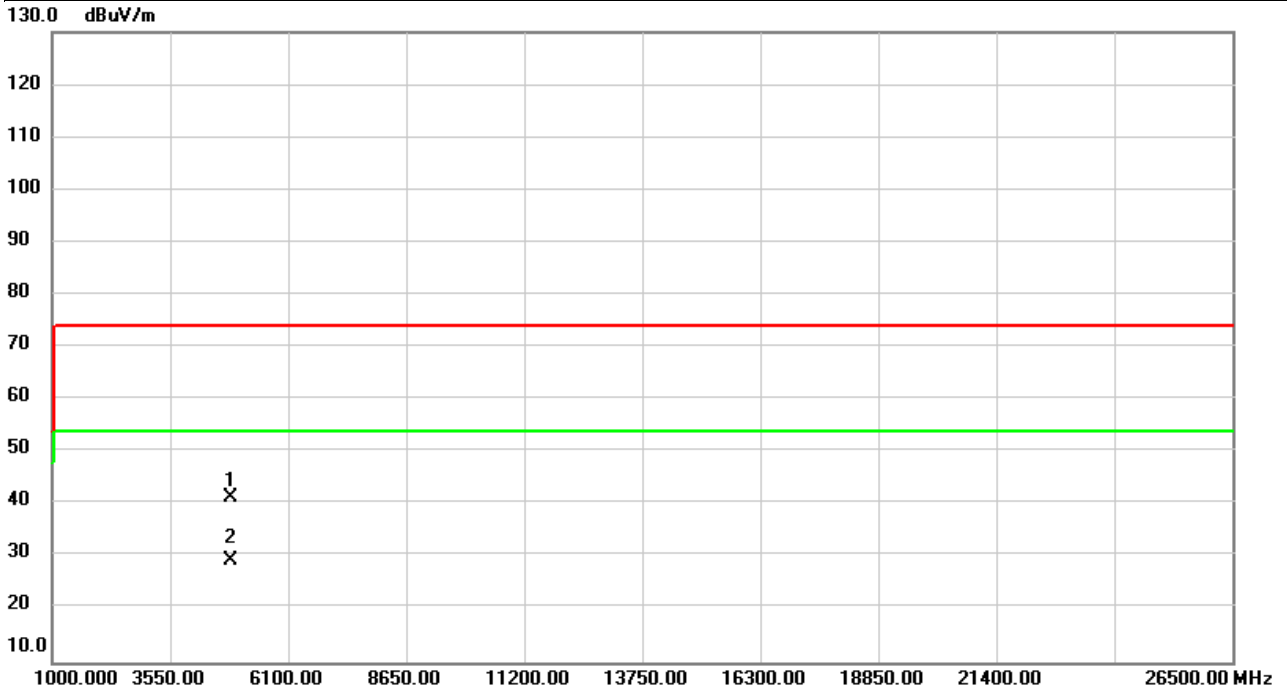

No.	Mk.	Freq. MHz	Reading Level dBuV	Correct Factor dB	Measure- ment dBuV/m	Limit dBuV/m	Over dB	Detector	Comment
1		4874.000	40.49	0.89	41.38	74.00	-32.62	peak	
2	*	4874.000	28.32	0.89	29.21	54.00	-24.79	AVG	

REMARKS:

- (1) Measurement Value = Reading Level + Correct Factor.
- (2) Margin Level = Measurement Value - Limit Value.

Test Mode	IEEE 802.11n (HT20)	Test Date	2022/9/8
Test Frequency	2437MHz	Polarization	Horizontal
Temp	26°C	Hum.	60%

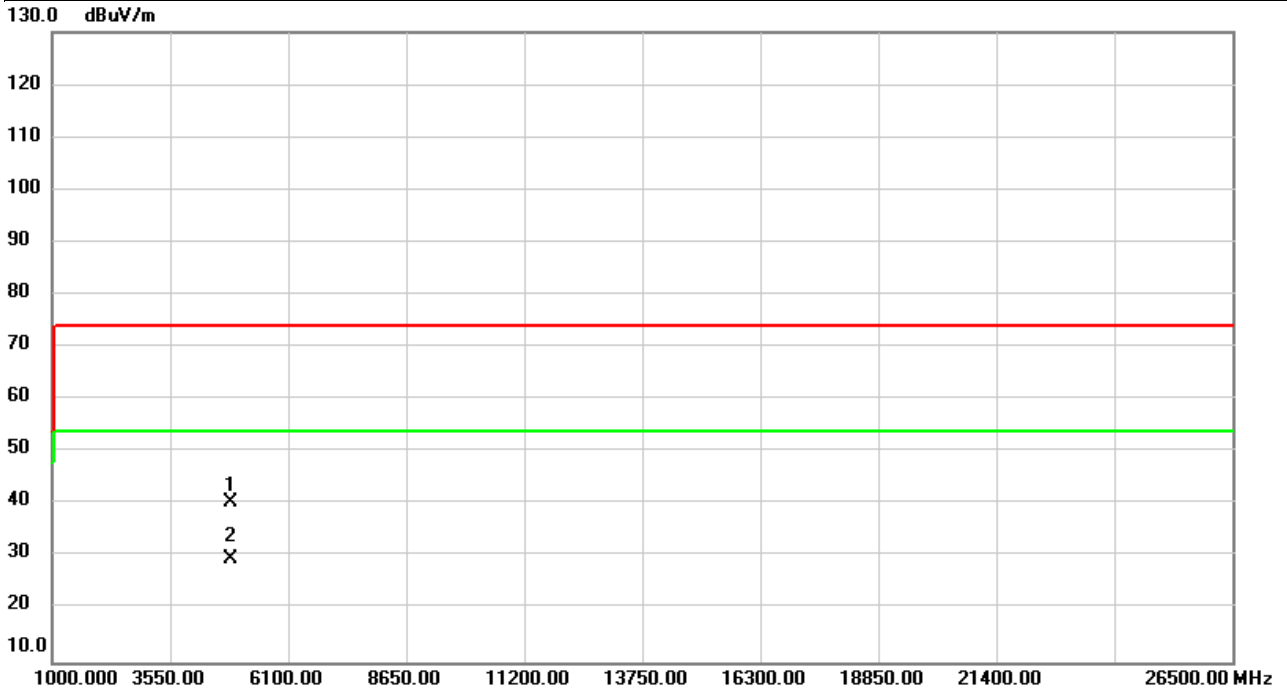

No.	Mk.	Freq. MHz	Reading Level dBuV	Correct Factor dB	Measure- ment dBuV/m	Limit dBuV/m	Over dB	Detector	Comment
1		4874.000	39.45	0.89	40.34	74.00	-33.66	peak	
2	*	4874.000	28.81	0.89	29.70	54.00	-24.30	AVG	

REMARKS:

- (1) Measurement Value = Reading Level + Correct Factor.
- (2) Margin Level = Measurement Value - Limit Value.

Test Mode	IEEE 802.11n (HT20)	Test Date	2022/9/8
Test Frequency	2462MHz	Polarization	Vertical
Temp	26°C	Hum.	60%

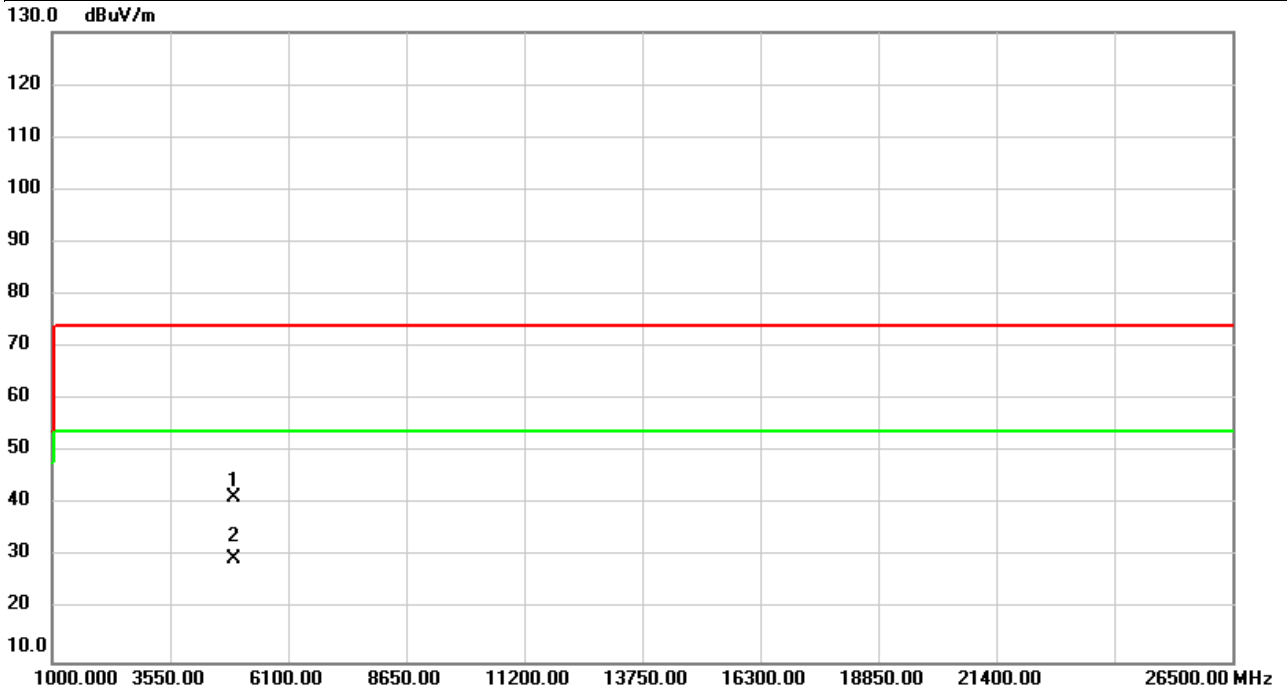

No.	Mk.	Freq. MHz	Reading Level dBuV	Correct Factor dB	Measure- ment dBuV/m	Limit dBuV/m	Over dB	Detector	Comment
1		4924.000	40.14	1.07	41.21	74.00	-32.79	peak	
2	*	4924.000	28.68	1.07	29.75	54.00	-24.25	AVG	

REMARKS:

- (1) Measurement Value = Reading Level + Correct Factor.
- (2) Margin Level = Measurement Value - Limit Value.

Test Mode	IEEE 802.11n (HT20)	Test Date	2022/9/8
Test Frequency	2462MHz	Polarization	Horizontal
Temp	26°C	Hum.	60%

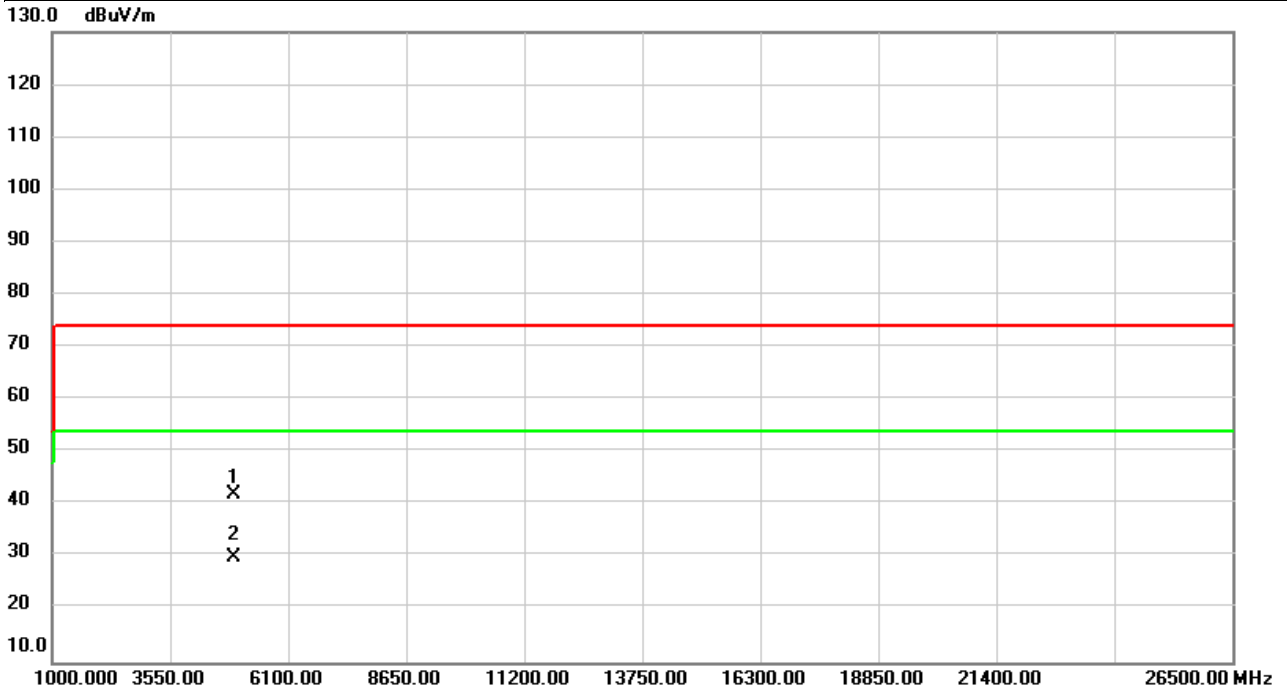

No.	Mk.	Freq. MHz	Reading Level dBuV	Correct Factor dB	Measure- ment dBuV/m	Limit dBuV/m	Over dB	Detector	Comment
1		4924.000	40.87	1.07	41.94	74.00	-32.06	peak	
2	*	4924.000	28.96	1.07	30.03	54.00	-23.97	AVG	

REMARKS:

- (1) Measurement Value = Reading Level + Correct Factor.
- (2) Margin Level = Measurement Value - Limit Value.

APPENDIX D BANDWIDTH

Test Mode	IEEE 802.11b_Main Antenna
-----------	---------------------------

Test Frequency (MHz)	6 dB Bandwidth (MHz)	99 % Occupied Bandwidth (MHz)	Minimum 6 dB Bandwidth Limit (kHz)	Result
2412	7.59	11.20	≥ 500	Pass
2437	7.55	11.20	≥ 500	Pass
2462	8.03	11.28	≥ 500	Pass

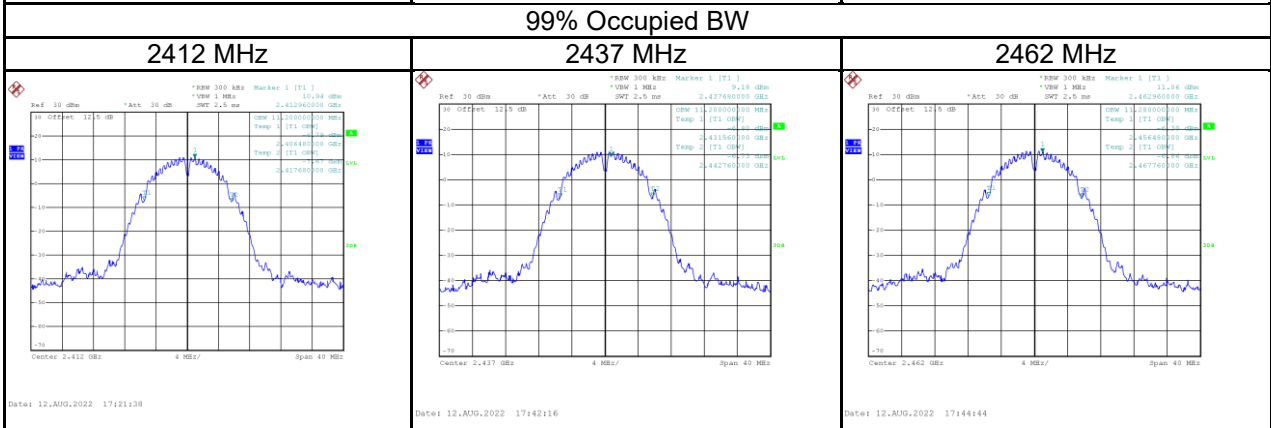
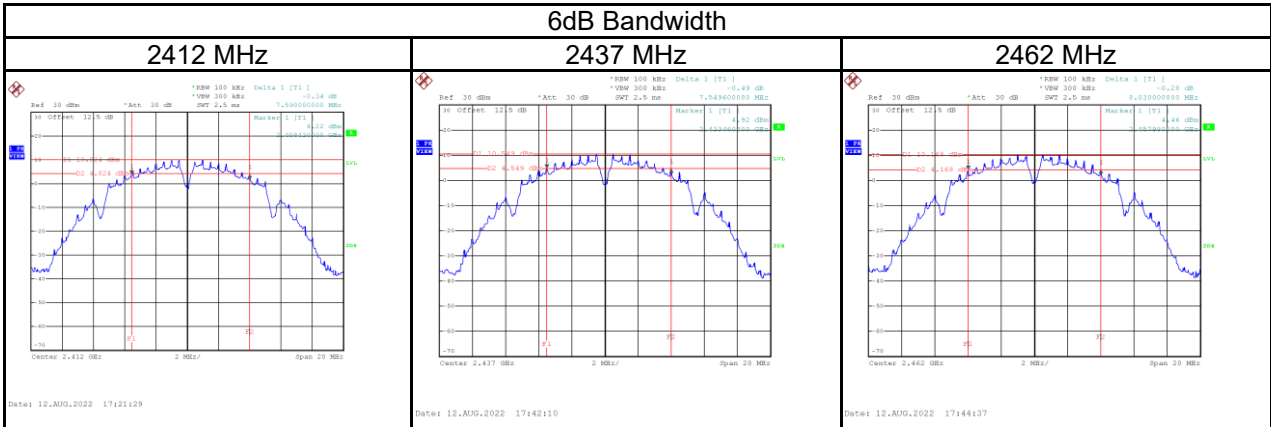

Test Mode	IEEE 802.11b_Aux Antenna
-----------	--------------------------

Test Frequency (MHz)	6 dB Bandwidth (MHz)	99 % Occupied Bandwidth (MHz)	Minimum 6 dB Bandwidth Limit (kHz)	Result
2412	7.56	11.36	≥ 500	Pass
2437	7.03	11.44	≥ 500	Pass
2462	7.55	11.44	≥ 500	Pass

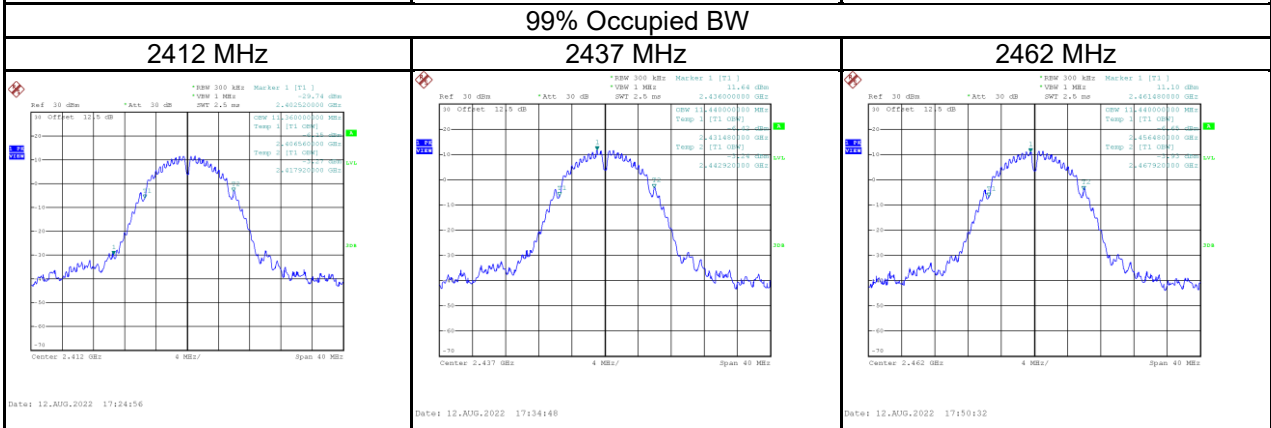
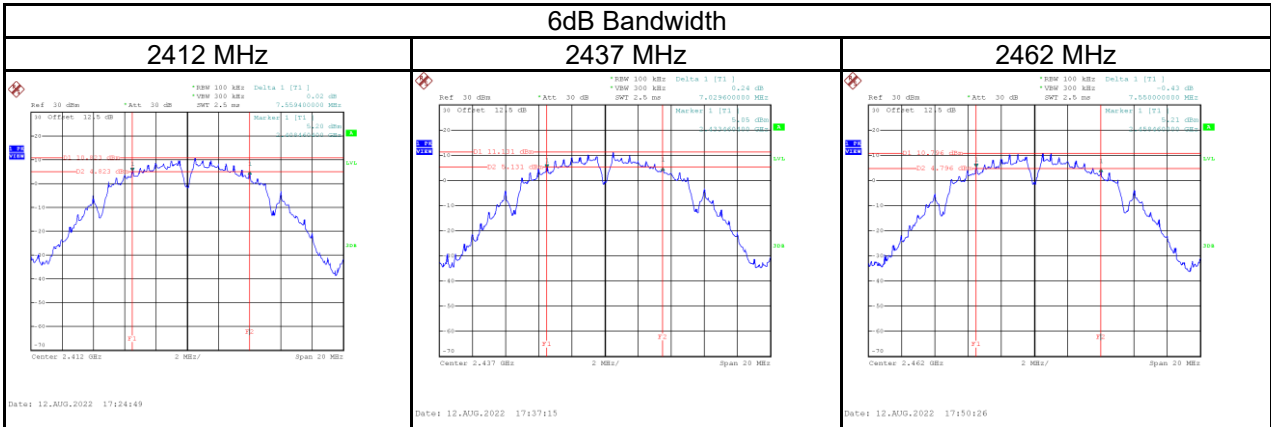

Test Mode	IEEE 802.11g_Main Antenna
-----------	---------------------------

Test Frequency (MHz)	6 dB Bandwidth (MHz)	99 % Occupied Bandwidth (MHz)	Minimum 6 dB Bandwidth Limit (kHz)	Result
2412	16.45	16.88	≥ 500	Pass
2437	16.40	16.88	≥ 500	Pass
2462	16.42	16.88	≥ 500	Pass

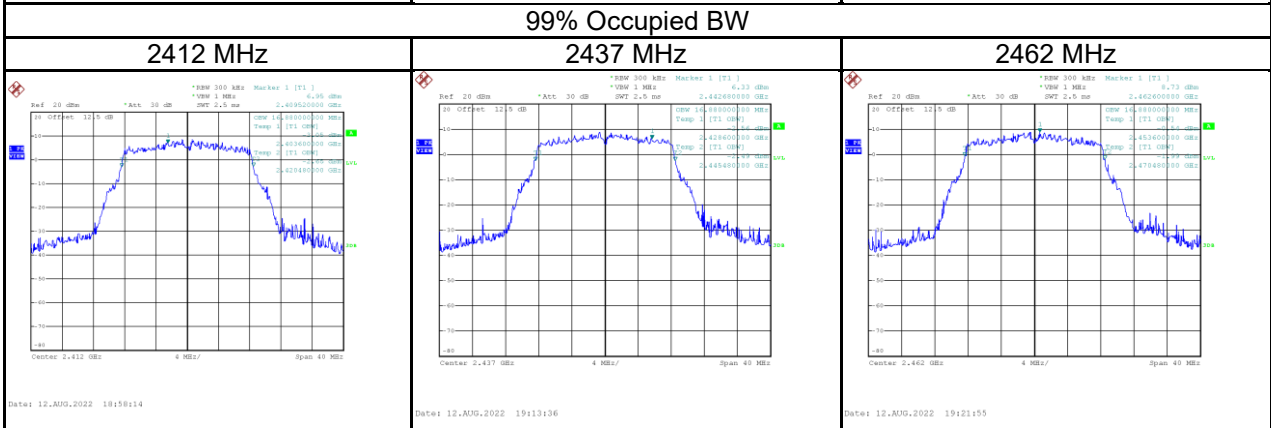
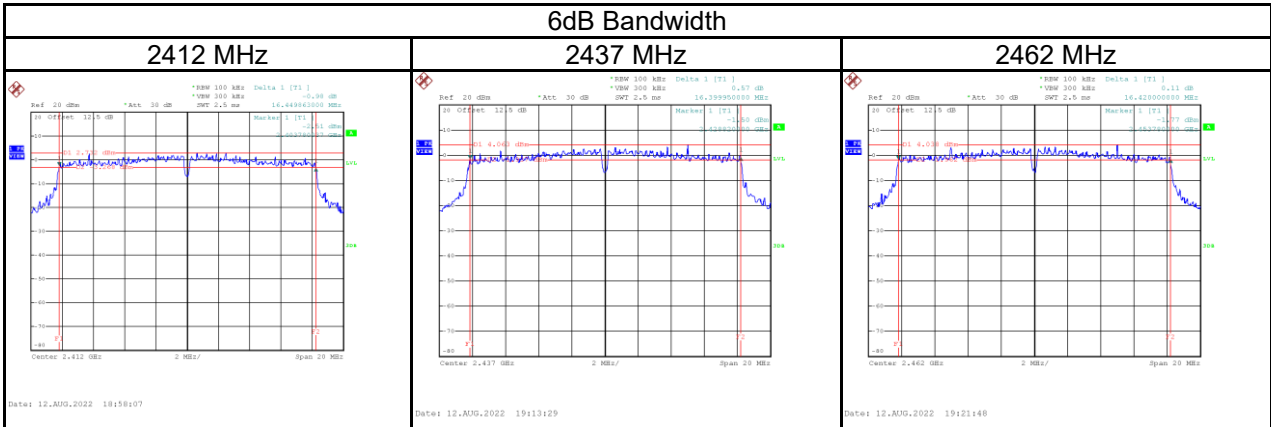

Test Mode	IEEE 802.11g_Aux Antenna
-----------	--------------------------

Test Frequency (MHz)	6 dB Bandwidth (MHz)	99 % Occupied Bandwidth (MHz)	Minimum 6 dB Bandwidth Limit (kHz)	Result
2412	16.43	17.04	≥ 500	Pass
2437	16.44	17.04	≥ 500	Pass
2462	16.44	17.04	≥ 500	Pass

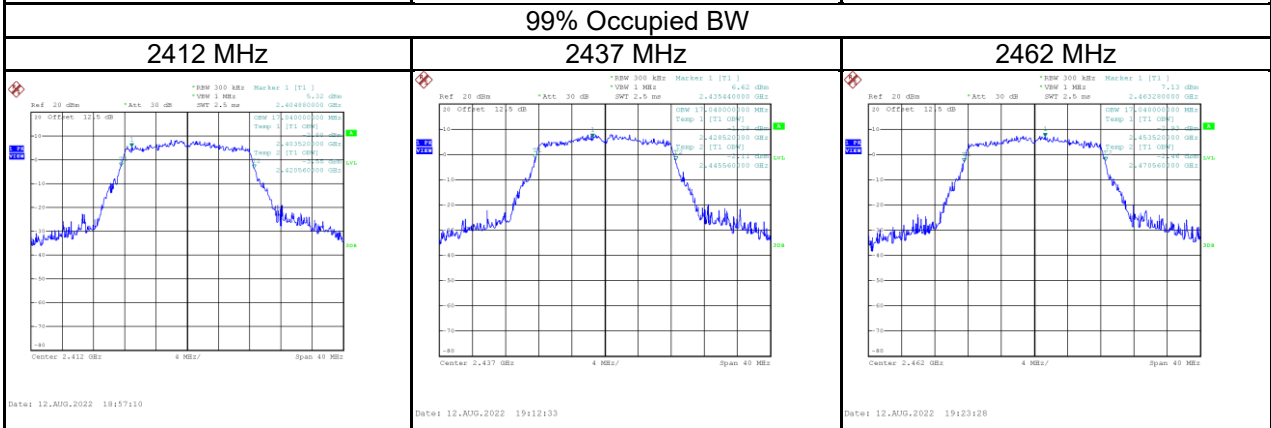
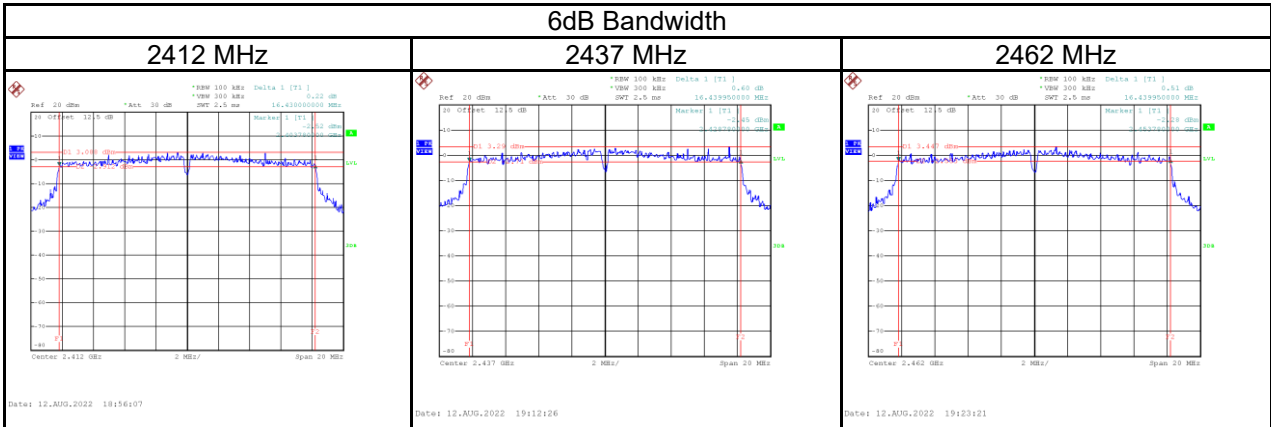

Test Mode	IEEE 802.11n (HT20)_Main Antenna
-----------	----------------------------------

Test Frequency (MHz)	6 dB Bandwidth (MHz)	99 % Occupied Bandwidth (MHz)	Minimum 6 dB Bandwidth Limit (kHz)	Result
2412	17.62	18.00	≥ 500	Pass
2437	17.63	18.00	≥ 500	Pass
2462	17.62	17.92	≥ 500	Pass

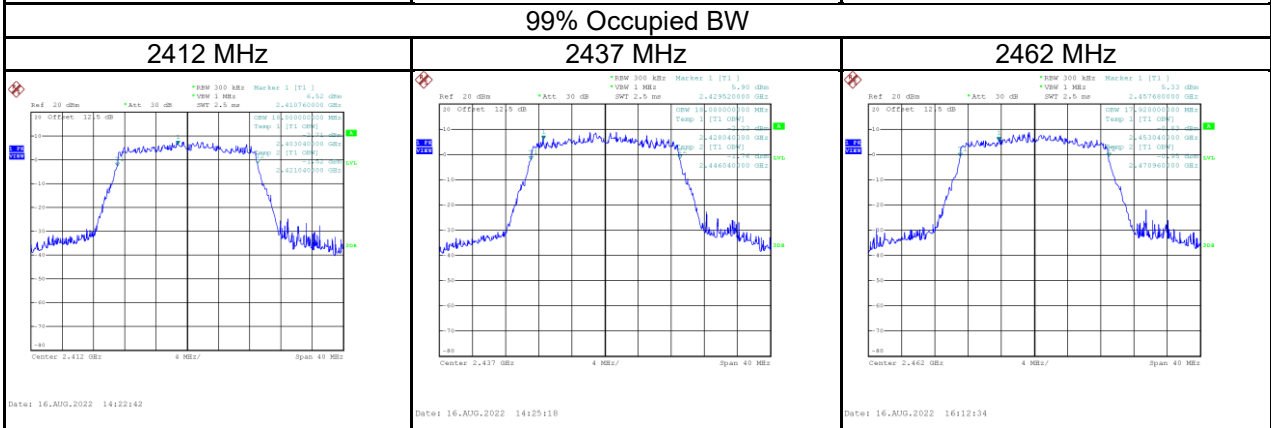
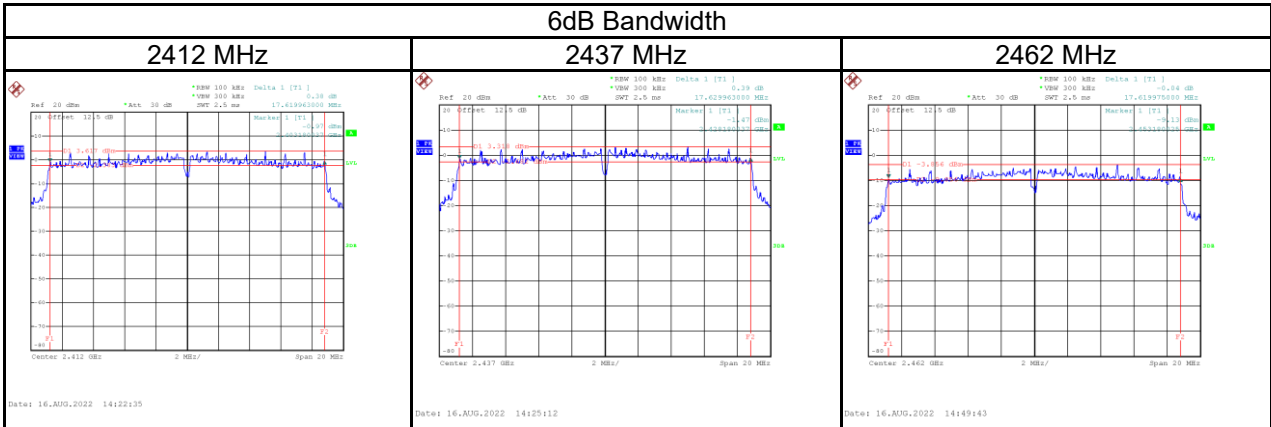

Test Mode	IEEE 802.11n (HT20)_Aux Antenna
-----------	---------------------------------

Test Frequency (MHz)	6 dB Bandwidth (MHz)	99 % Occupied Bandwidth (MHz)	Minimum 6 dB Bandwidth Limit (kHz)	Result
2412	17.64	18.16	≥ 500	Pass
2437	17.64	18.16	≥ 500	Pass
2462	17.62	18.24	≥ 500	Pass

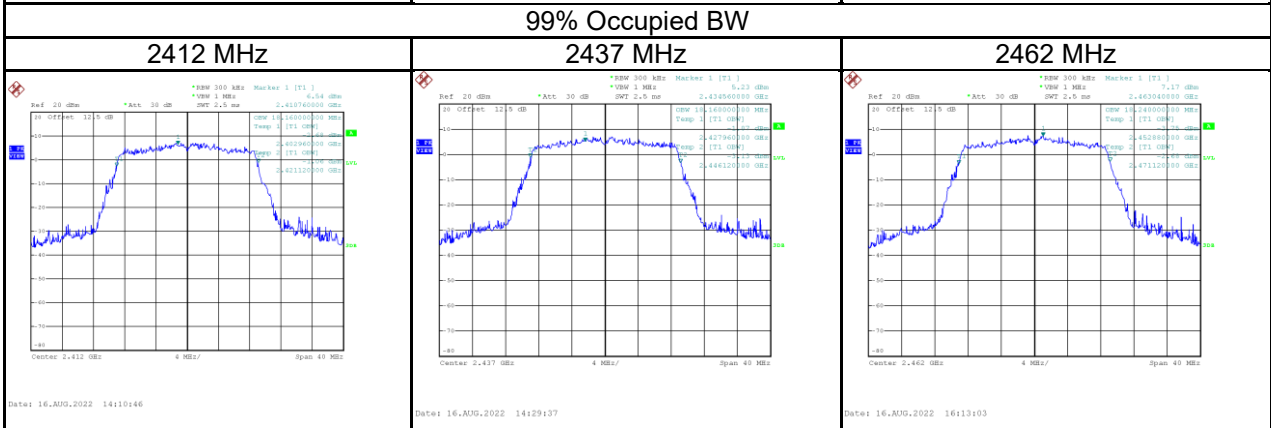
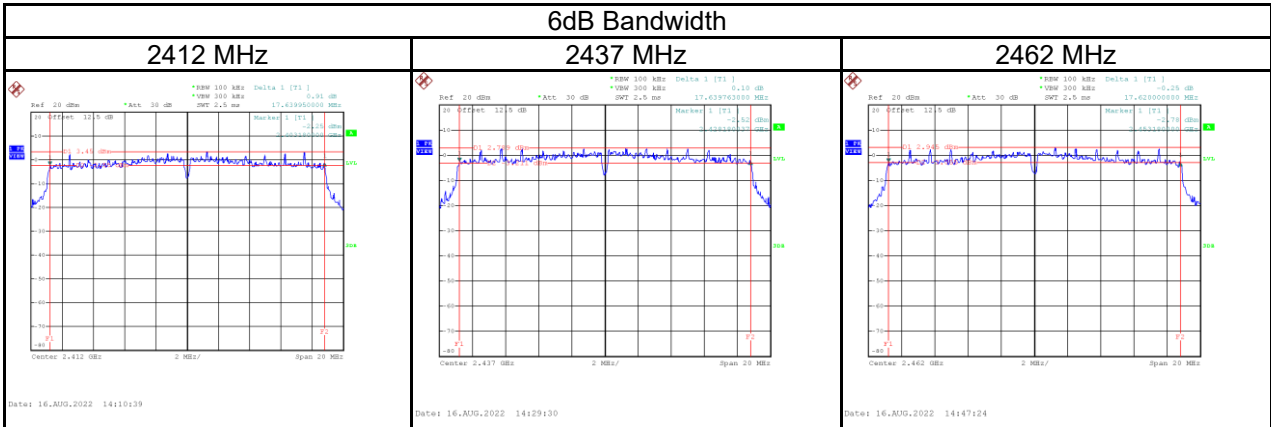

APPENDIX E OUTPUT POWER

Test Mode	IEEE 802.11b_Main Antenna	Tested Date	2022/9/1
-----------	---------------------------	-------------	----------

Frequency (MHz)	Conducted Power (dBm)	Conducted Power (W)	Limit (dBm)	Limit (W)	Result
2412	17.39	0.0548	30.00	1.0000	Complies
2437	17.43	0.0553	30.00	1.0000	Complies
2462	17.36	0.0545	30.00	1.0000	Complies

Test Mode	IEEE 802.11b_Aux Antenna	Tested Date	2022/9/1
-----------	--------------------------	-------------	----------

Frequency (MHz)	Conducted Power (dBm)	Conducted Power (W)	Limit (dBm)	Limit (W)	Result
2412	17.25	0.0531	30.00	1.0000	Complies
2437	17.40	0.0550	30.00	1.0000	Complies
2462	17.21	0.0526	30.00	1.0000	Complies

Test Mode	IEEE 802.11g_Main Antenna	Tested Date	2022/9/1
-----------	---------------------------	-------------	----------

Frequency (MHz)	Conducted Power (dBm)	Conducted Power (W)	Limit (dBm)	Limit (W)	Result
2412	24.15	0.2600	30.00	1.0000	Complies
2437	24.28	0.2679	30.00	1.0000	Complies
2462	23.84	0.2421	30.00	1.0000	Complies

Test Mode	IEEE 802.11g_Aux Antenna	Tested Date	2022/9/1
-----------	--------------------------	-------------	----------

Frequency (MHz)	Conducted Power (dBm)	Conducted Power (W)	Limit (dBm)	Limit (W)	Result
2412	23.44	0.2208	30.00	1.0000	Complies
2437	23.52	0.2249	30.00	1.0000	Complies
2462	23.39	0.2183	30.00	1.0000	Complies

Test Mode	IEEE 802.11g_Total	Tested Date	2022/9/1
-----------	--------------------	-------------	----------

Frequency (MHz)	Conducted Power (dBm)	Conducted Power (W)	Limit (dBm)	Limit (W)	Result
2412	26.82	0.4808	30.00	1.0000	Complies
2437	26.93	0.4928	30.00	1.0000	Complies
2462	26.63	0.4604	30.00	1.0000	Complies

Test Mode	IEEE 802.11n (HT20)_Main Antenna	Tested Date	2022/9/1
-----------	----------------------------------	-------------	----------

Frequency (MHz)	Conducted Power (dBm)	Conducted Power (W)	Limit (dBm)	Limit (W)	Result
2412	24.06	0.2547	30.00	1.0000	Complies
2437	23.96	0.2489	30.00	1.0000	Complies
2462	23.94	0.2477	30.00	1.0000	Complies

Test Mode	IEEE 802.11n (HT20)_Aux Antenna	Tested Date	2022/9/1
-----------	---------------------------------	-------------	----------

Frequency (MHz)	Conducted Power (dBm)	Conducted Power (W)	Limit (dBm)	Limit (W)	Result
2412	23.65	0.2317	30.00	1.0000	Complies
2437	23.53	0.2254	30.00	1.0000	Complies
2462	23.27	0.2123	30.00	1.0000	Complies

Test Mode	IEEE 802.11n (HT20)_Total	Tested Date	2022/9/1
-----------	---------------------------	-------------	----------

Frequency (MHz)	Conducted Power (dBm)	Conducted Power (W)	Limit (dBm)	Limit (W)	Result
2412	26.87	0.4864	30.00	1.0000	Complies
2437	26.76	0.4743	30.00	1.0000	Complies
2462	26.63	0.4601	30.00	1.0000	Complies

APPENDIX F POWER SPECTRAL DENSITY

Test Mode	IEEE 802.11b_Main Antenna
-----------	---------------------------

Test Frequency (MHz)	Power Spectral Density (dBm/3kHz)	Maximum Limit (dBm/3kHz)	Result
2412	-4.65	8.00	Pass
2437	-4.00	8.00	Pass
2462	-4.81	8.00	Pass

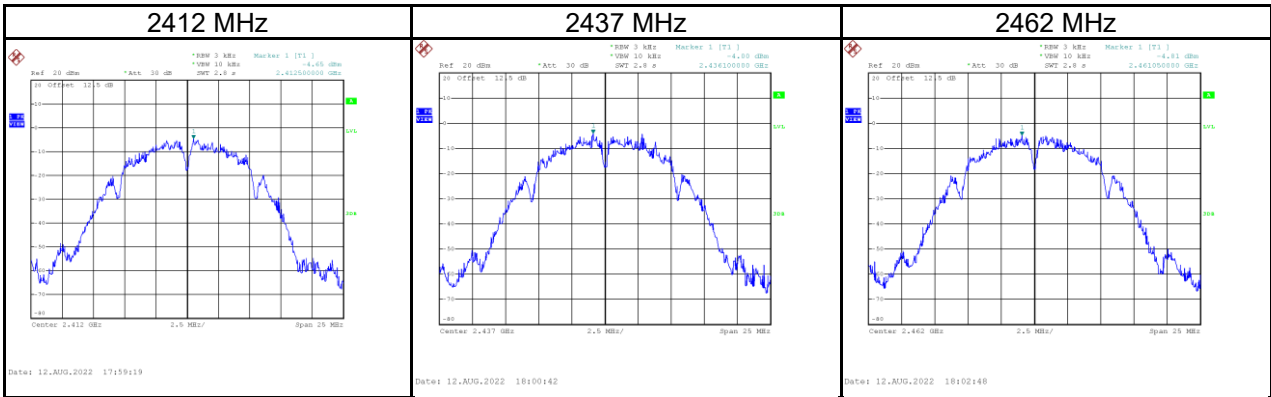

Test Mode	IEEE 802.11b_Aux Antenna
-----------	--------------------------

Test Frequency (MHz)	Power Spectral Density (dBm/3kHz)	Maximum Limit (dBm/3kHz)	Result
2412	-4.55	8.00	Pass
2437	-3.26	8.00	Pass
2462	-4.33	8.00	Pass

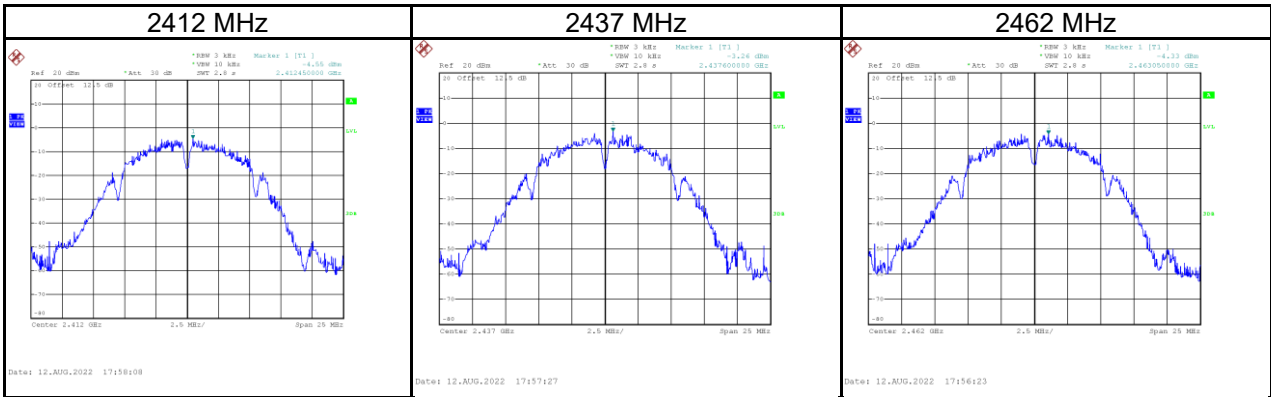

Test Mode	IEEE 802.11g_Main Antenna
-----------	---------------------------

Test Frequency (MHz)	Power Spectral Density (dBm/3kHz)	Maximum Limit (dBm/3kHz)	Result
2412	-9.05	8.00	Pass
2437	-8.86	8.00	Pass
2462	-7.73	8.00	Pass

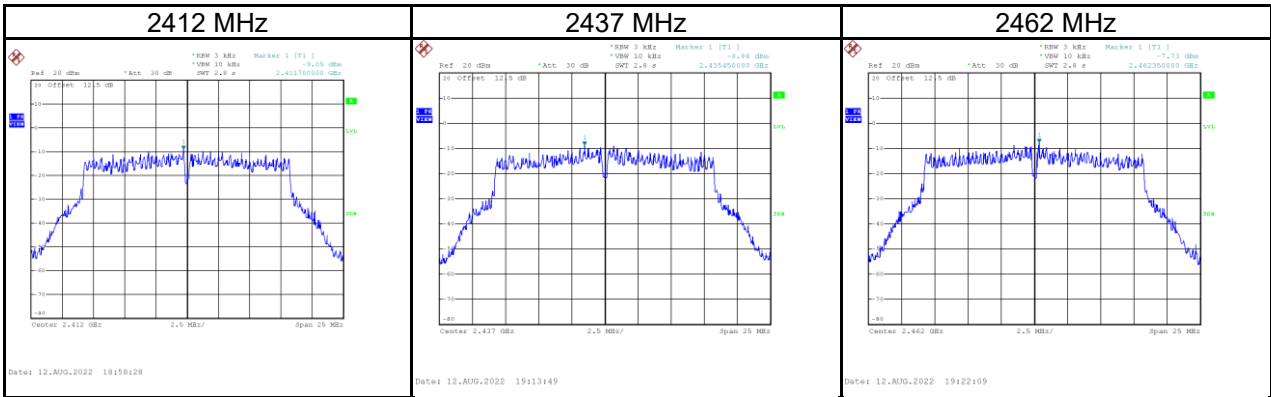

Test Mode	IEEE 802.11g_Aux Antenna
-----------	--------------------------

Test Frequency (MHz)	Power Spectral Density (dBm/3kHz)	Maximum Limit (dBm/3kHz)	Result
2412	-8.83	8.00	Pass
2437	-9.79	8.00	Pass
2462	-8.66	8.00	Pass

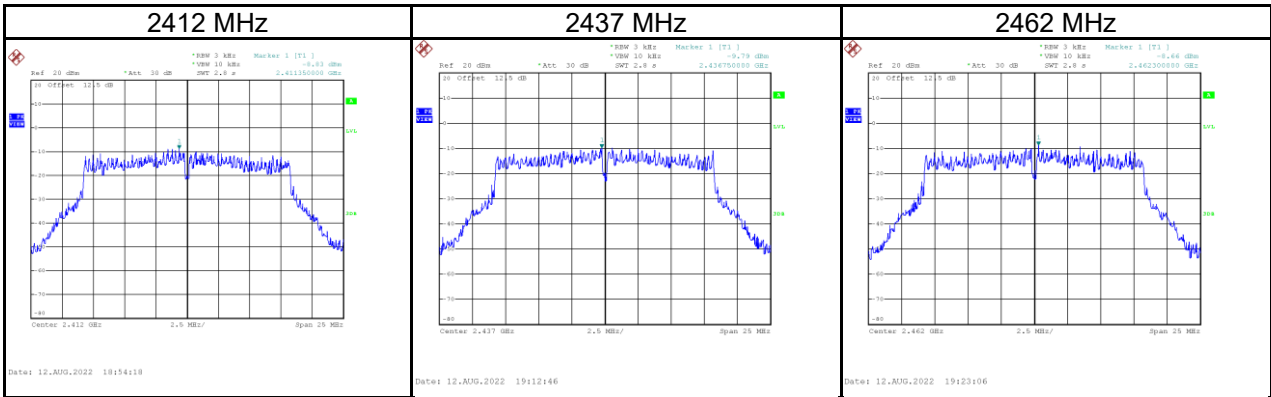

Test Mode	IEEE 802.11g_Total
-----------	--------------------

Test Frequency (MHz)	Power Spectral Density (dBm/3kHz)	Maximum Limit (dBm/3kHz)	Result
2412	-5.93	8.00	Pass
2437	-6.29	8.00	Pass
2462	-5.16	8.00	Pass

Test Mode	IEEE 802.11n (HT20)_Main Antenna
-----------	----------------------------------

Test Frequency (MHz)	Power Spectral Density (dBm/3kHz)	Maximum Limit (dBm/3kHz)	Result
2412	-10.21	8.00	Pass
2437	-10.64	8.00	Pass
2462	-10.36	8.00	Pass

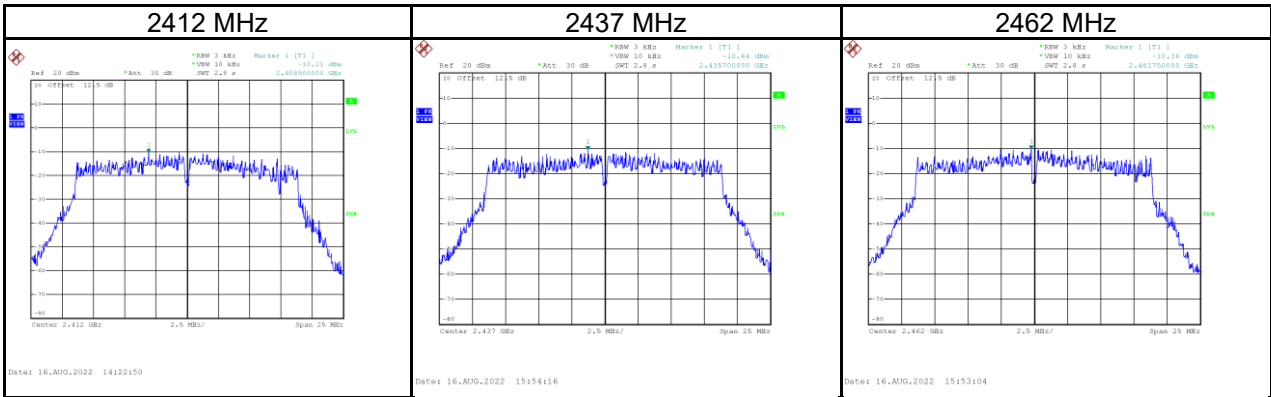

Test Mode	IEEE 802.11n (HT20)_Aux Antenna
-----------	---------------------------------

Test Frequency (MHz)	Power Spectral Density (dBm/3kHz)	Maximum Limit (dBm/3kHz)	Result
2422	-9.60	8.00	Pass
2437	-10.35	8.00	Pass
2452	-10.08	8.00	Pass

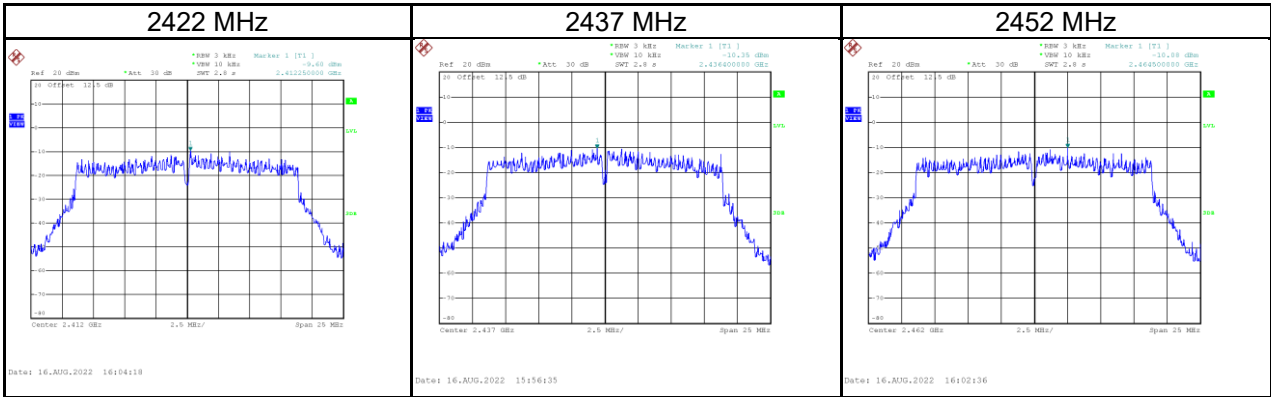

Test Mode	IEEE 802.11n (HT20)_Total
-----------	---------------------------

Test Frequency (MHz)	Power Spectral Density (dBm/3kHz)	Maximum Limit (dBm/3kHz)	Result
2412	-6.88	8.00	Pass
2437	-7.48	8.00	Pass
2462	-7.21	8.00	Pass

APPENDIX G ANTENNA CONDUCTED SPURIOUS EMISSIONS

Test Mode IEEE 802.11b_Main Antenna

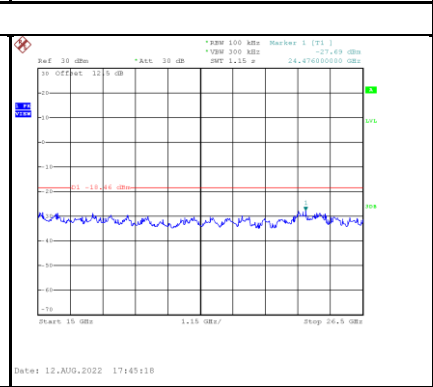
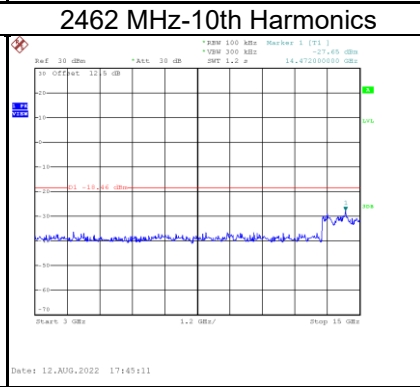
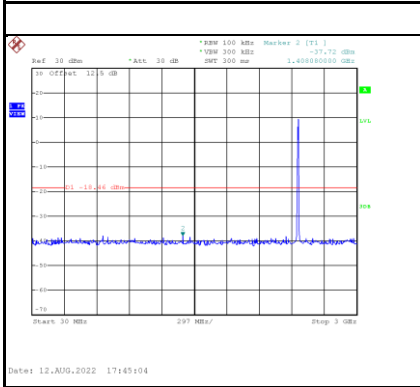
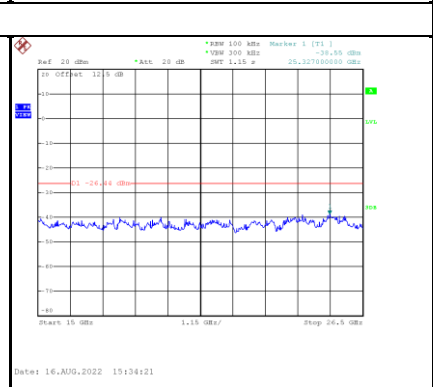
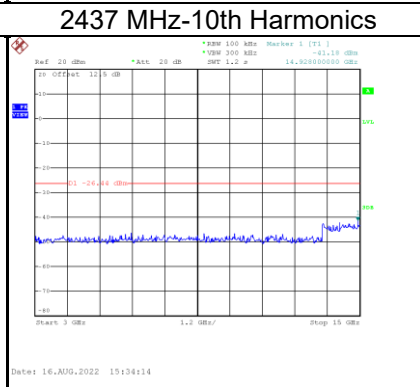
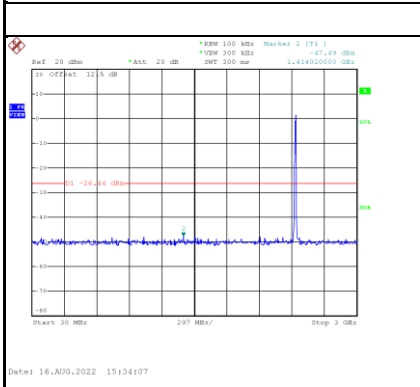
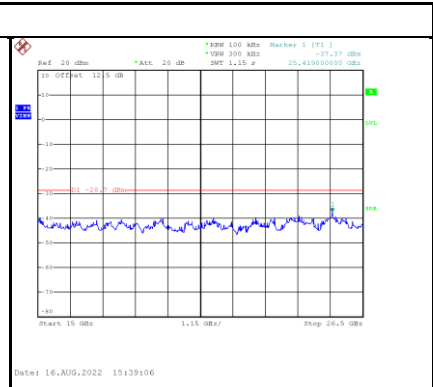
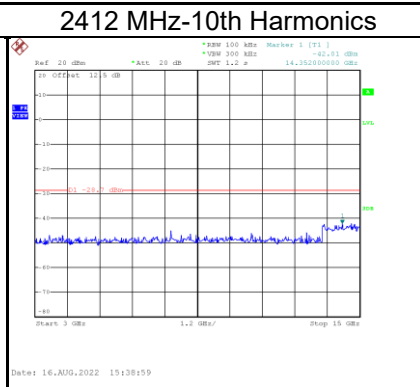
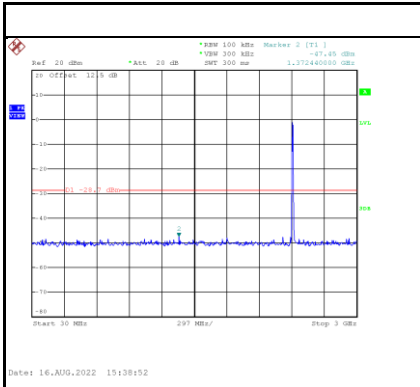
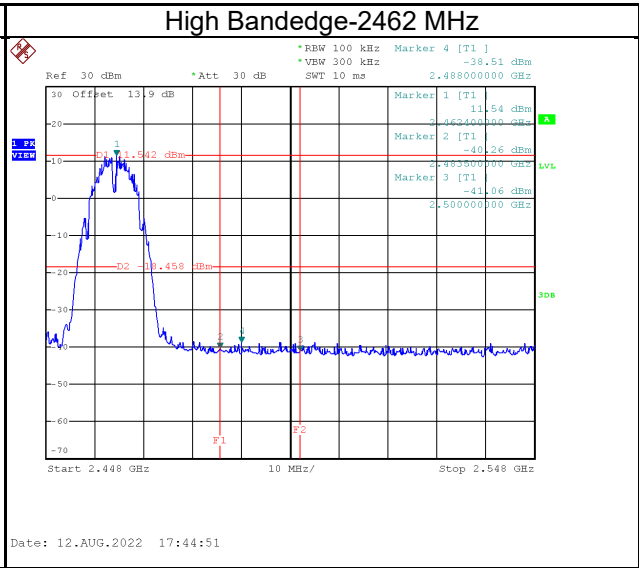
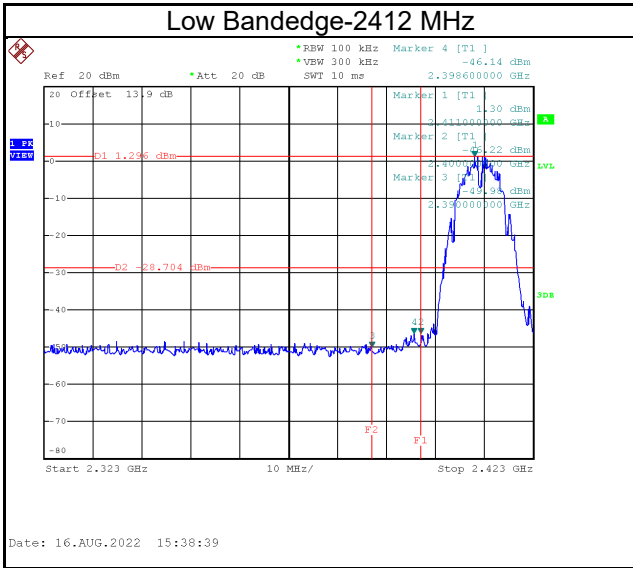

Test Mode IEEE 802.11b_Aux Antenna

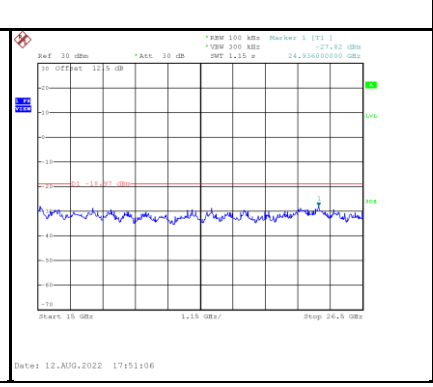
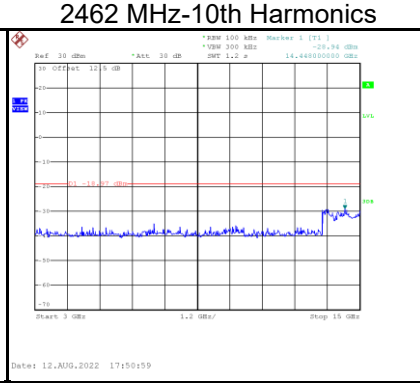
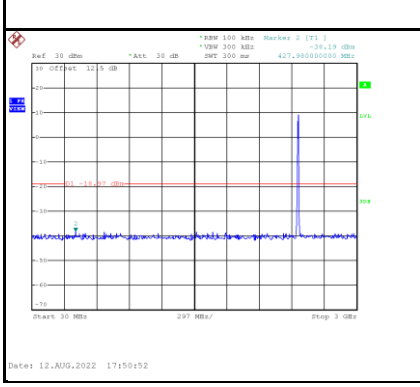
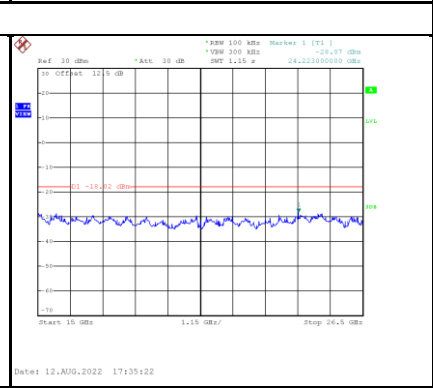
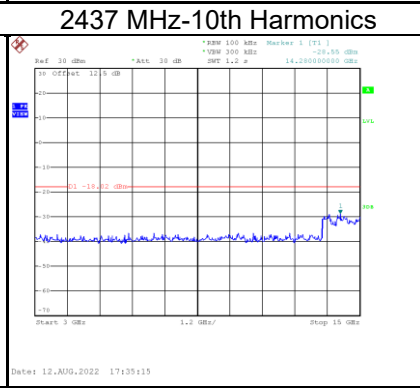
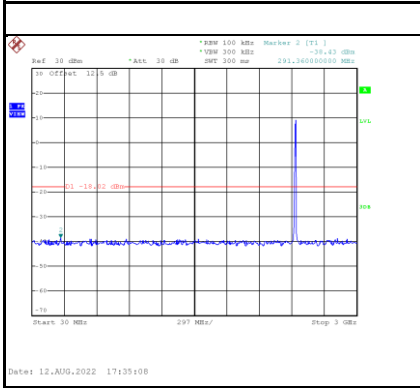
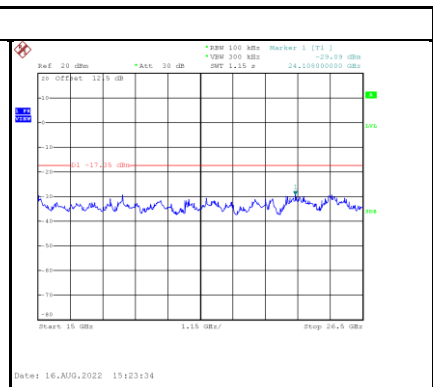
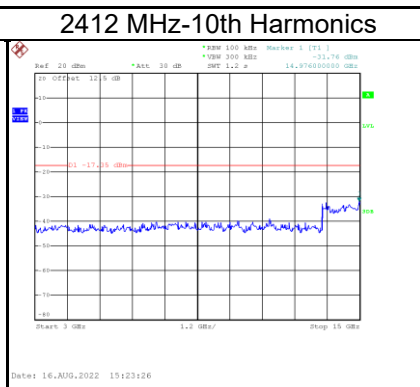
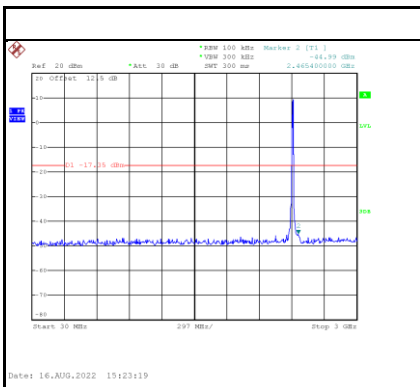
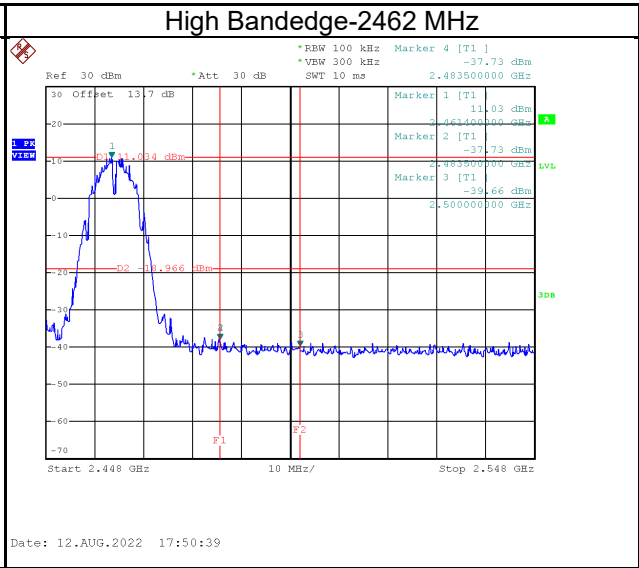
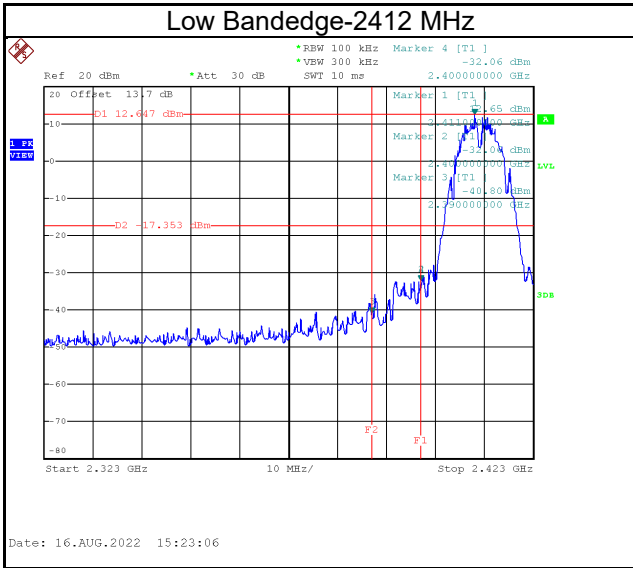

Test Mode IEEE 802.11g_Main Antenna

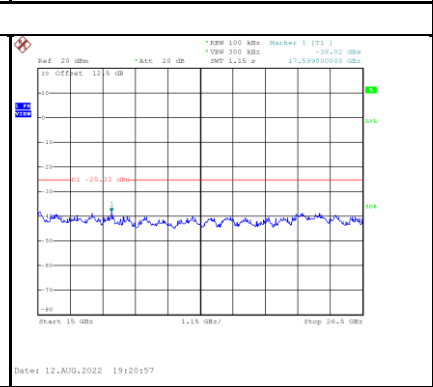
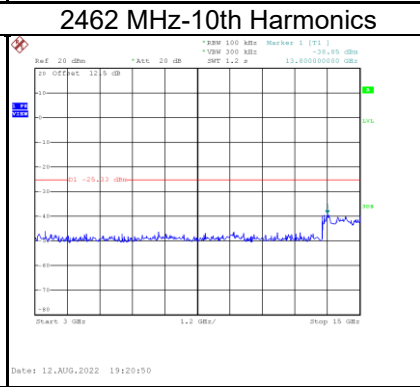
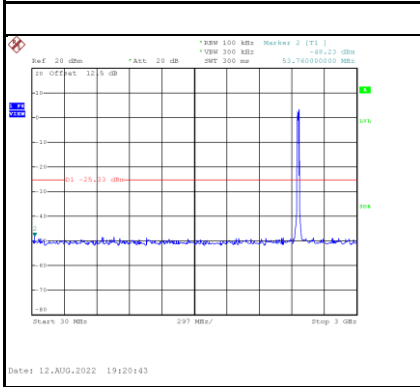
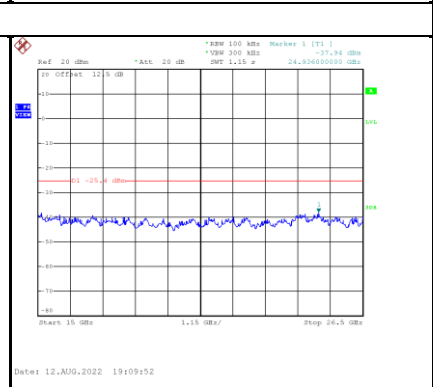
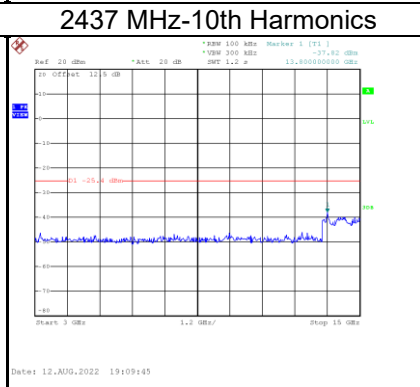
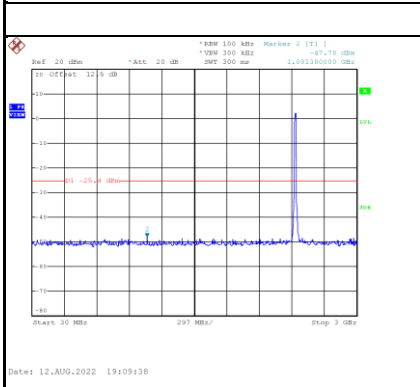
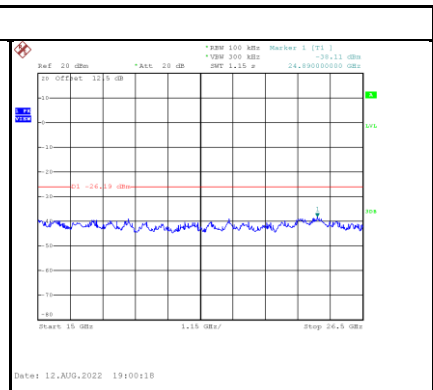
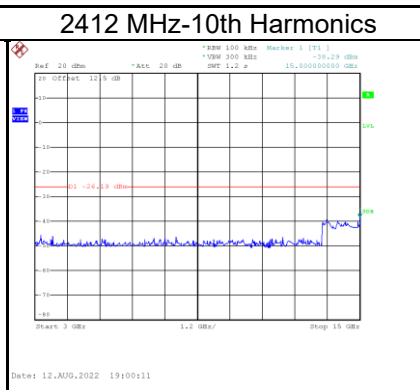
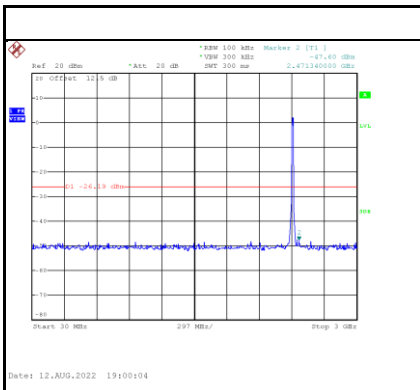
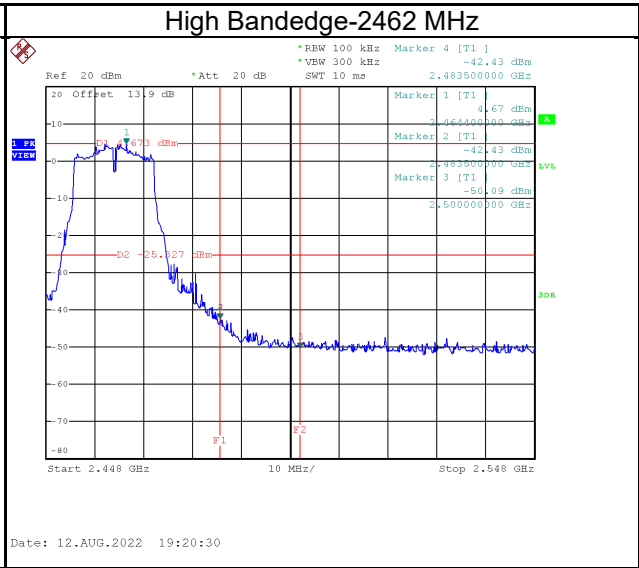
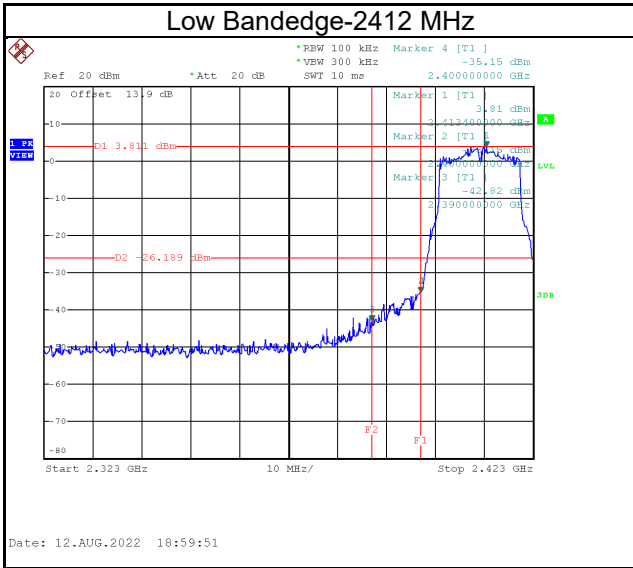

Test Mode IEEE 802.11g_Aux Antenna

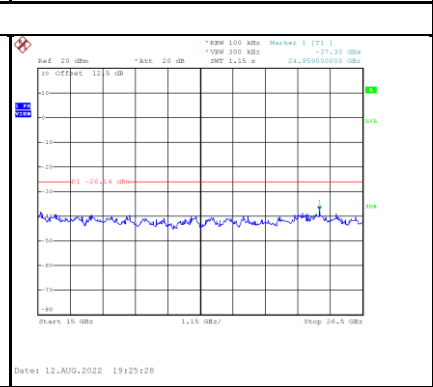
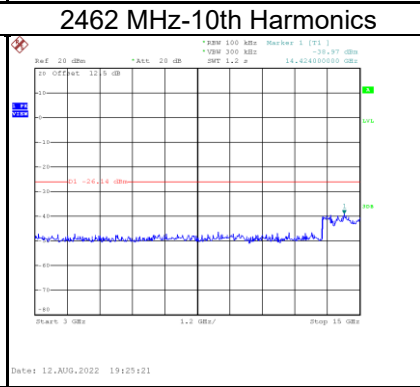
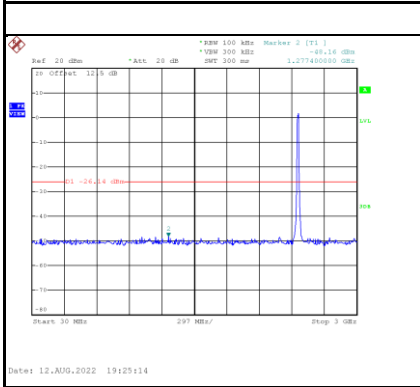
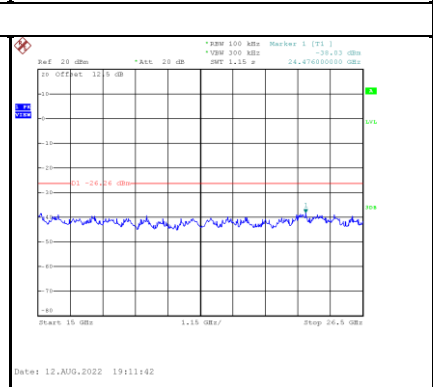
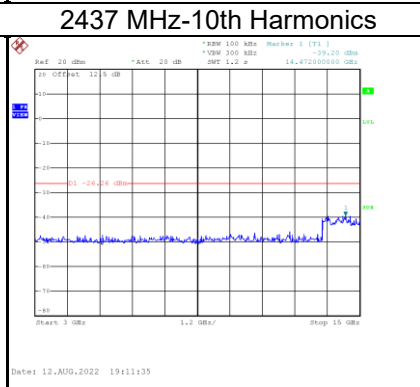
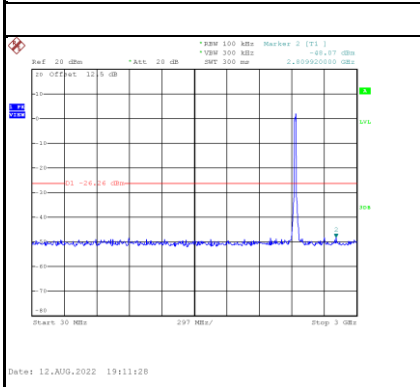
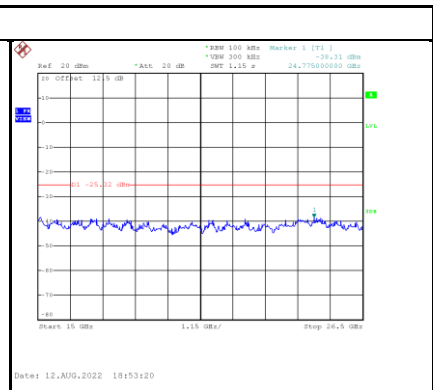
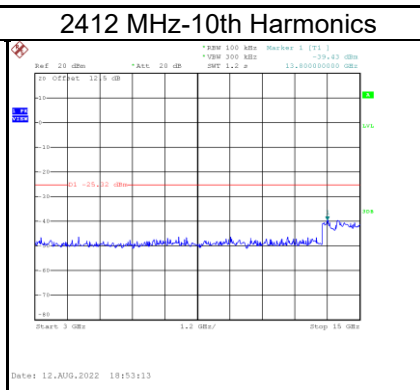
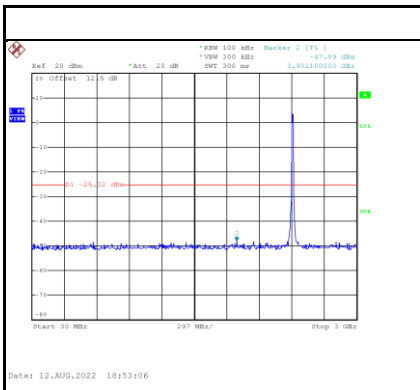
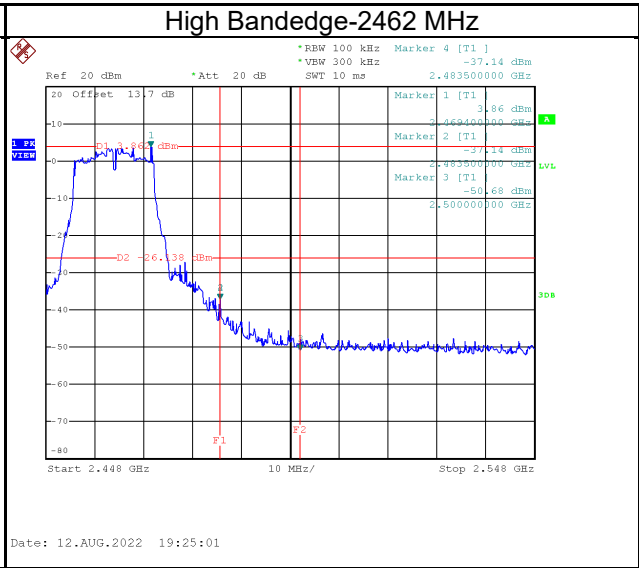
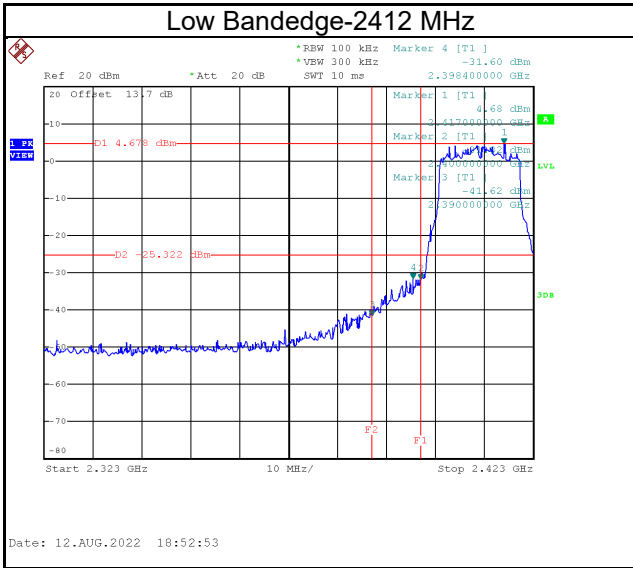

Test Mode IEEE 802.11n (HT20)_Main Antenna

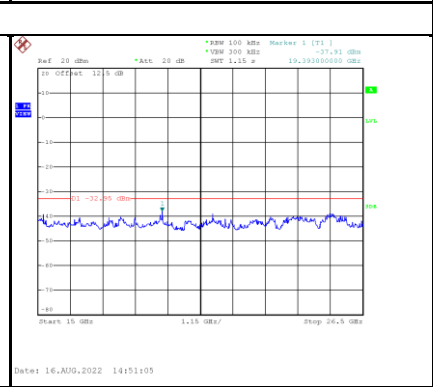
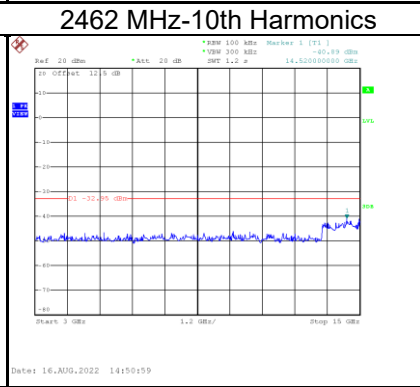
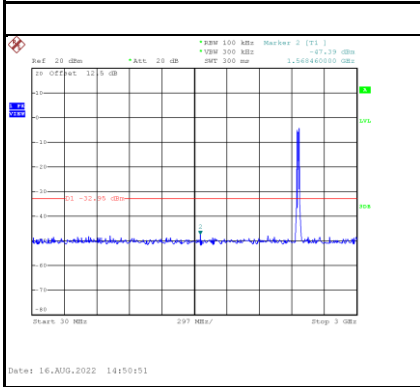
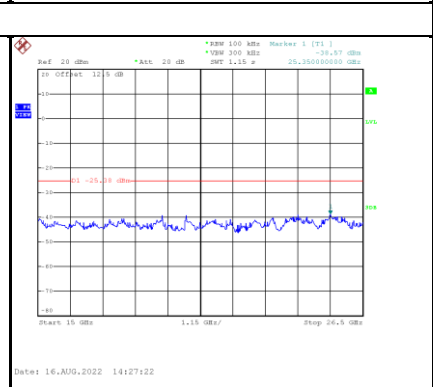
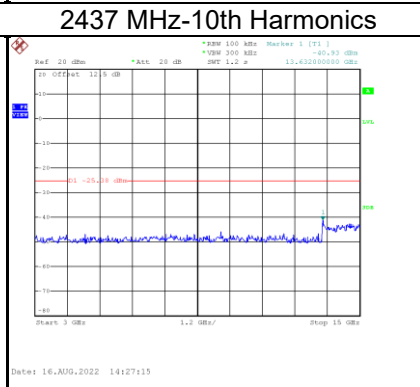
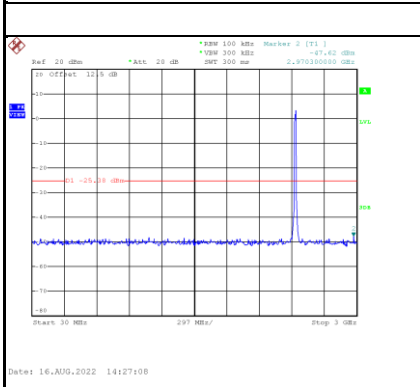
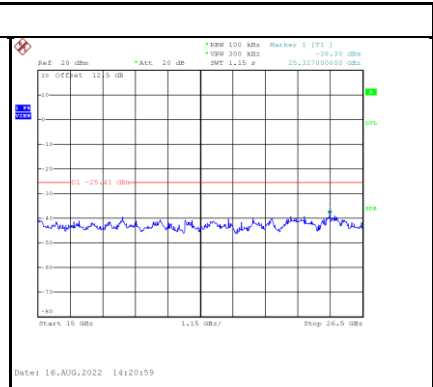
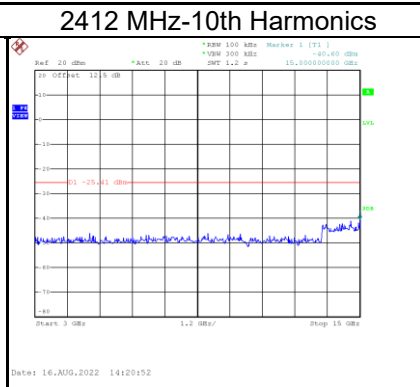
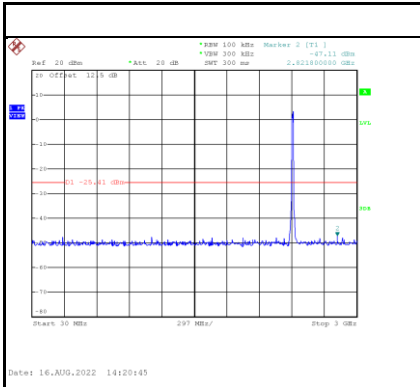
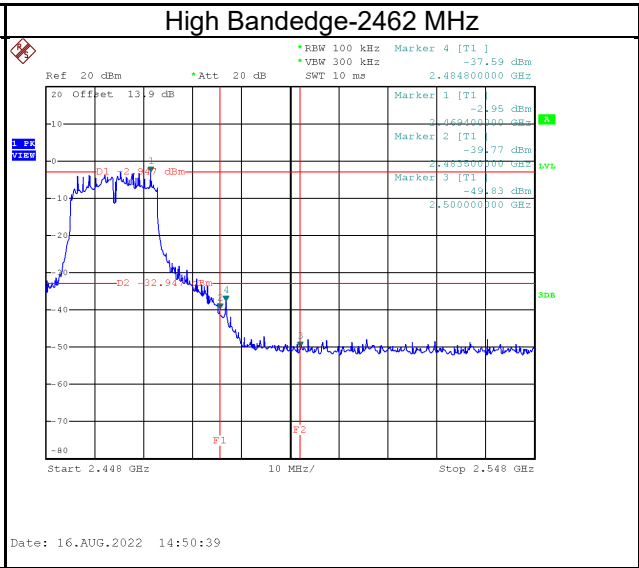
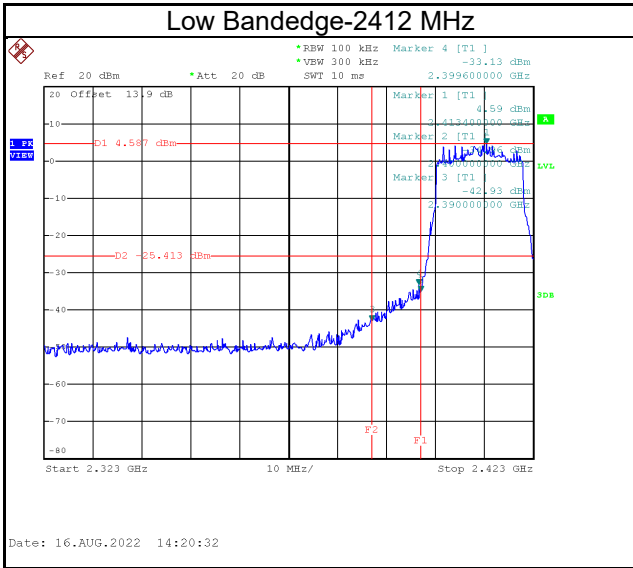

Test Mode IEEE 802.11n (HT20)_Aux Antenna

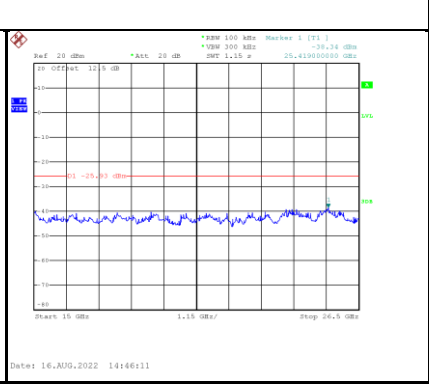
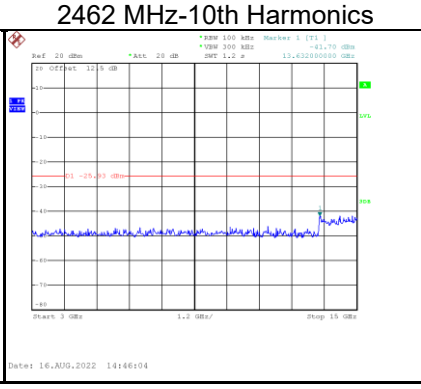
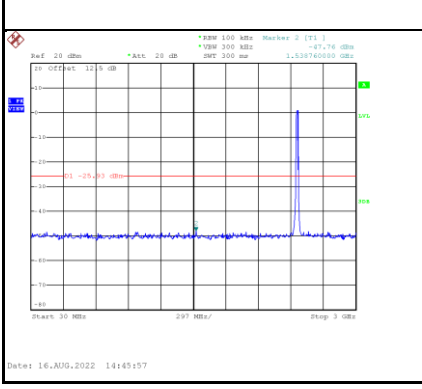
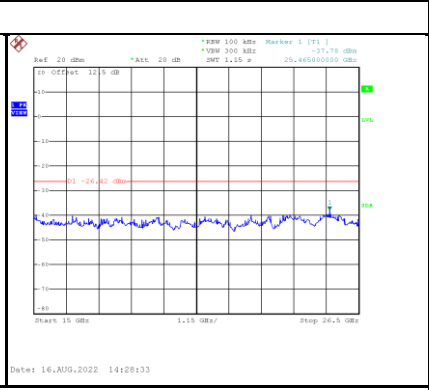
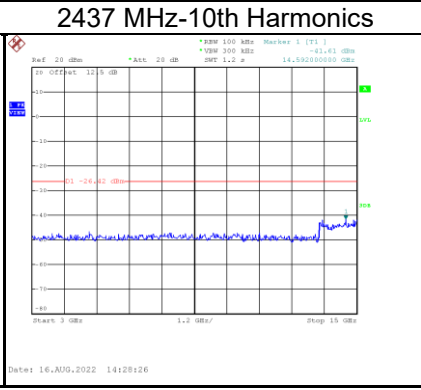
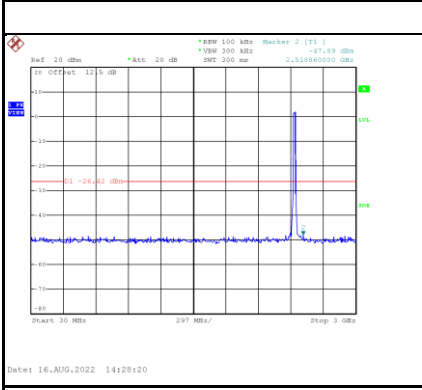
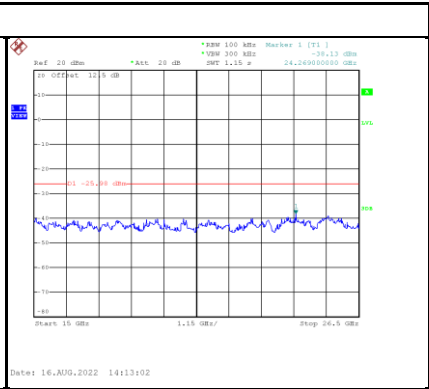
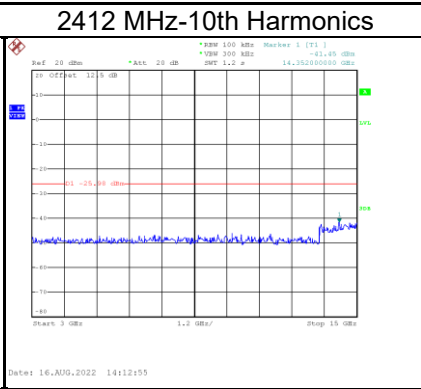
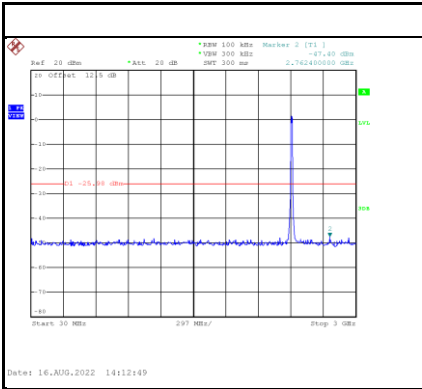
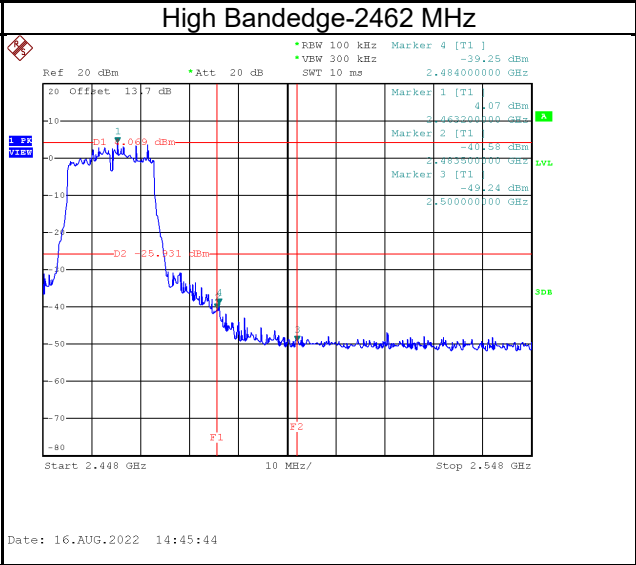
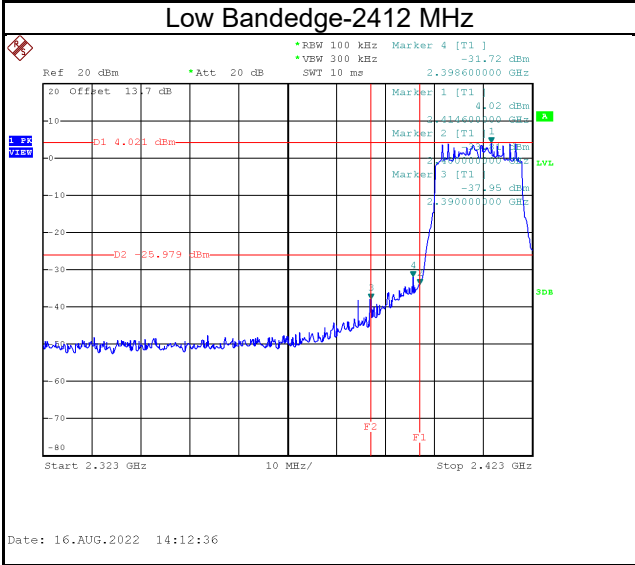

End of Test Report