

FCC Radio Test Report

FCC ID: BBP-WLEIG01

Report No. : BTL-FCCP-2-2207T020
Equipment : portable monitor
Model Name : RICOH Portable Monitor 150BW, RICOH Light Monitor 150BW
Brand Name : RICOH
Applicant : Ricoh Company Ltd
Address : 2-7-1 Izumi Ebina, Kanagawa, 243-0460 Japan

Radio Function : RLAN 5 GHz (U-NII 1, U-NII 2A, U-NII 2C)

FCC Rule Part(s) : FCC CFR Title 47, Part 15, Subpart E (15.407)
Measurement Procedure(s) : ANSI C63.10-2013

Date of Receipt : 2022/7/8
Date of Test : 2022/7/8~ 2022/9/27
Issued Date : 2022/10/6

The above equipment has been tested and found in compliance with the requirement of the above standards by BTL Inc.

Prepared by :

Eric Lee, Engineer

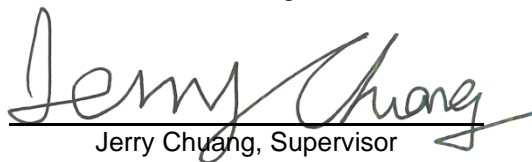
Approved by :

Jerry Chuang, Supervisor

**BTL Inc.**

No.18, Ln. 171, Sec. 2, Jiuzong Rd., Neihu Dist., Taipei City 114, Taiwan

Tel: +886-2-2657-3299 Fax: +886-2-2657-3331 Web: www.newbtl.com Service mail: btl_qa@newbtl.com

Declaration

BTL represents to the client that testing is done in accordance with standard procedures as applicable and that test instruments used has been calibrated with standards traceable to international standard(s) and/or national standard(s).

BTL's reports apply only to the specific samples tested under conditions. It is manufacture's responsibility to ensure that additional production units of this model are manufactured with the identical electrical and mechanical components. **BTL** shall have no liability for any declarations, inferences or generalizations drawn by the client or others from **BTL** issued reports.

This report is the confidential property of the client. As a mutual protection to the clients, the public and ourselves, the test report shall not be reproduced, except in full, without our written approval.

BTL's laboratory quality assurance procedures are in compliance with the **ISO/IEC 17025** requirements, and accredited by the conformity assessment authorities listed in this test report.

BTL is not responsible for the sampling stage, so the results only apply to the sample as received.

The information, data and test plan are provided by manufacturer which may affect the validity of results, so it is manufacturer's responsibility to ensure that the apparatus meets the essential requirements of applied standards and in all the possible configurations as representative of its intended use.

Limitation

For the use of the authority's logo is limited unless the Test Standard(s)/Scope(s)/Item(s) mentioned in this test report is (are) included in the conformity assessment authorities acceptance respective.

Please note that the measurement uncertainty is provided for informational purpose only and are not use in determining the Pass/Fail results.

CONTENTS

REVISION HISTORY	5
1 SUMMARY OF TEST RESULTS	6
1.1 TEST FACILITY	7
1.2 MEASUREMENT UNCERTAINTY	7
1.3 TEST ENVIRONMENT CONDITIONS	7
1.4 TABLE OF PARAMETERS OF TEST SOFTWARE SETTING	8
1.5 DUTY CYCLE	9
2 GENERAL INFORMATION	11
2.1 DESCRIPTION OF EUT	11
2.2 TEST MODES	14
2.3 BLOCK DIAGRAM SHOWING THE CONFIGURATION OF SYSTEM TESTED	15
2.4 SUPPORT UNITS	16
3 AC POWER LINE CONDUCTED EMISSIONS TEST	17
3.1 LIMIT	17
3.2 TEST PROCEDURE	17
3.3 DEVIATION FROM TEST STANDARD	17
3.4 TEST SETUP	18
3.5 TEST RESULT	18
4 RADIATED EMISSIONS TEST	19
4.1 LIMIT	19
4.2 TEST PROCEDURE	20
4.3 DEVIATION FROM TEST STANDARD	20
4.4 TEST SETUP	21
4.5 EUT OPERATING CONDITIONS	22
4.6 TEST RESULT – BELOW 30 MHZ	22
4.7 TEST RESULT – 30 MHZ TO 1 GHZ	22
4.8 TEST RESULT – ABOVE 1 GHZ	22
5 BANDWIDTH TEST	23
5.1 LIMIT	23
5.2 TEST PROCEDURE	23
5.3 DEVIATION FROM TEST STANDARD	23
5.4 TEST SETUP	23
5.5 EUT OPERATING CONDITIONS	23
5.6 TEST RESULT	23
6 OUTPUT POWER TEST	24
6.1 LIMIT	24
6.2 TEST PROCEDURE	24
6.3 DEVIATION FROM TEST STANDARD	24
6.4 TEST SETUP	24
6.5 EUT OPERATING CONDITIONS	24
6.6 TEST RESULT	24
7 POWER SPECTRAL DENSITY	25
7.1 LIMIT	25
7.2 TEST PROCEDURE	25
7.3 DEVIATION FROM TEST STANDARD	25
7.4 TEST SETUP	25
7.5 EUT OPERATING CONDITIONS	25

7.6	TEST RESULT	25
8	LIST OF MEASURING EQUIPMENTS	26
9	EUT TEST PHOTO	28
10	EUT PHOTOS	28
APPENDIX A	AC POWER LINE CONDUCTED EMISSIONS	29
APPENDIX B	RADIATED EMISSIONS - 30 MHZ TO 1 GHZ	34
APPENDIX C	RADIATED EMISSIONS - ABOVE 1 GHZ	37
APPENDIX D	BANDWIDTH	123
APPENDIX E	CONDUCTED OUTPUT POWER	143
APPENDIX F	POWER SPECTRAL DENSITY	153

REVISION HISTORY

Report No.	Version	Description	Issued Date	Note
BTL-FCCP-2-2207T020	R00	Original Report.	2022/10/6	Valid

1 SUMMARY OF TEST RESULTS

Test procedures according to the technical standards.

Standard(s) Section	Description	Test Result	Judgement	Remark
15.207	AC Power Line Conducted Emissions	APPENDIX A	Pass	-----
15.205 15.209 15.407(b)	Radiated Emissions	APPENDIX B APPENDIX C	Pass	-----
15.407(a)	Bandwidth	APPENDIX D	Pass	-----
15.407(a)	Output Power	APPENDIX E	Pass	-----
15.407(a)	Power Spectral Density	APPENDIX F	Pass	-----
15.203	Antenna Requirement	-----	Pass	-----
15.407(c)	Automatically Discontinue Transmission	-----	Pass	NOTE (3)

NOTE:

- (1) "N/A" denotes test is not applicable in this Test Report.
- (2) The report format version is TP.1.1.1.
- (3) The EUT can detect the controlling signal of ACK message transmitting from remote device and verify whether it shall resend or discontinue transmission.

1.1 TEST FACILITY

The test facilities used to collect the test data in this report:

No. 72, Ln. 169, Sec. 2, Datong Rd., Xizhi Dist., New Taipei City 221, Taiwan

The test sites and facilities are covered under FCC RN: 674415 and DN: TW0659.

C06 CB21 CB22

No. 68-1, Ln. 169, Sec. 2, Datong Rd., Xizhi Dist., New Taipei City 221, Taiwan

The test sites and facilities are covered under FCC RN: 674415 and DN: TW0659.

C05 CB08 CB11 CB15 CB16
 SR05

1.2 MEASUREMENT UNCERTAINTY

The reported uncertainty of measurement $y \pm U$, where expanded uncertainty U is based on a standard uncertainty multiplied by a coverage factor of $k = 2$, providing a level of confidence of approximately **95 %**. The measurement instrumentation uncertainty considerations contained in CISPR 16-4-2. The BTL measurement uncertainty is less than the CISPR 16-4-2 U_{cispr} requirement.

A. AC power line conducted emissions test:

Test Site	Method	Measurement Frequency Range	U (dB)
C05	CISPR	150 kHz ~ 30MHz	3.44

B. Radiated emissions test :

Test Site	Measurement Frequency Range	U,(dB)
CB21	0.03 GHz ~ 0.2 GHz	4.17
	0.2 GHz ~ 1 GHz	4.72
	1 GHz ~ 6 GHz	5.21
	6 GHz ~ 18 GHz	5.51
	18 GHz ~ 26 GHz	3.69
	26 GHz ~ 40 GHz	4.23

C. Conducted test :

Test Item	U,(dB)
Occupied Bandwidth	0.5332
Output power	0.3669
Power Spectral Density	0.6590
Conducted Spurious emissions	0.5416
Conducted Band edges	0.5335
Frequency Stability	0.5333

NOTE:

Unless specifically mentioned, the uncertainty of measurement has not been taken into account to declare the compliance or non-compliance to the specification.

1.3 TEST ENVIRONMENT CONDITIONS

Test Item	Environment Condition	Test Voltage	Tested by
AC Power Line Conducted Emissions	21 °C, 51 %	AC 120V	Jay Tien
Radiated emissions below 1 GHz	25 °C, 62 %	AC 120V	Mark Wang
Radiated emissions above 1 GHz	25 °C, 62 %	AC 120V	Mark Wang
Bandwidth	23.6 °C, 51 %	AC 120V	Angela Wang
Output Power	23.6 °C, 51 %	AC 120V	Angela Wang
Power Spectral Density	23.6 °C, 51 %	AC 120V	Angela Wang

1.4 TABLE OF PARAMETERS OF TEST SOFTWARE SETTING

UNII-1				
Test Software	Tera Term V4.97			
Mode	5180 MHz	5200 MHz	5240 MHz	Data Rate
IEEE 802.11a	9	9	9	6 Mbps
IEEE 802.11n (HT20)	9	9	9	HT 8
IEEE 802.11ac (VHT20)	9	9	9	VHT8
Mode	5190 MHz	5230 MHz		Data Rate
IEEE 802.11n (HT40)	10	10		HT 8
IEEE 802.11ac (VHT40)	10	10		VHT8
Mode	5210 MHz			Data Rate
IEEE 802.11ac (VHT80)	10			VHT8

UNII-2A				
Test Software	Tera Term V4.97			
Mode	5260 MHz	5300 MHz	5320 MHz	Data Rate
IEEE 802.11a	9	9	9	6 Mbps
IEEE 802.11n (HT20)	9	9	9	HT 8
IEEE 802.11ac (VHT20)	9	9	9	VHT8
Mode	5270 MHz	5310 MHz		Data Rate
IEEE 802.11n (HT40)	9	9		HT 8
IEEE 802.11ac (VHT40)	9	9		VHT8
Mode	5290 MHz			Data Rate
IEEE 802.11ac (VHT80)	10			VHT8

UNII-2C					
Test Software	Tera Term V4.97				
Mode	5500 MHz	5580 MHz	5700 MHz	5720 MHz	Data Rate
IEEE 802.11a	8	8	8	8	6 Mbps
IEEE 802.11n (HT20)	8	8	8	8	HT 8
IEEE 802.11ac (VHT20)	8	8	8	8	VHT8
Mode	5510 MHz	5550 MHz	5670 MHz	5710 MHz	Data Rate
IEEE 802.11n (HT40)	9	9	9	9	HT 8
IEEE 802.11ac (VHT40)	9	9	9	9	VHT8
Mode	5530 MHz	5690 MHz			Data Rate
IEEE 802.11ac (VHT80)	10	9			VHT8

1.5 DUTY CYCLE

If duty cycle is $\geq 98\%$, duty factor is not required.

If duty cycle is $< 98\%$, duty factor shall be considered.

Remark	Delta 1			Delta 2	On Time/Period	10 log(1/Duty Cycle)
Mode	ON (ms)	Numbers (ON)	On Time (B) (ms)	Period (ON+OFF) (ms)	Duty Cycle (%)	Duty Factor (dB)
IEEE 802.11a	1.470	1	1.470	2.050	71.71%	1.44
IEEE 802.11n (HT20)	0.966	1	0.966	1.008	95.83%	0.18
IEEE 802.11n (HT40)	0.750	1	0.750	0.810	92.59%	0.33
IEEE 802.11ac (VHT20)	1.310	1	1.310	1.450	90.34%	0.44
IEEE 802.11ac (VHT40)	0.624	1	0.624	0.760	82.11%	0.86
IEEE 802.11ac (VHT80)	0.306	1	0.306	0.434	70.51%	1.52

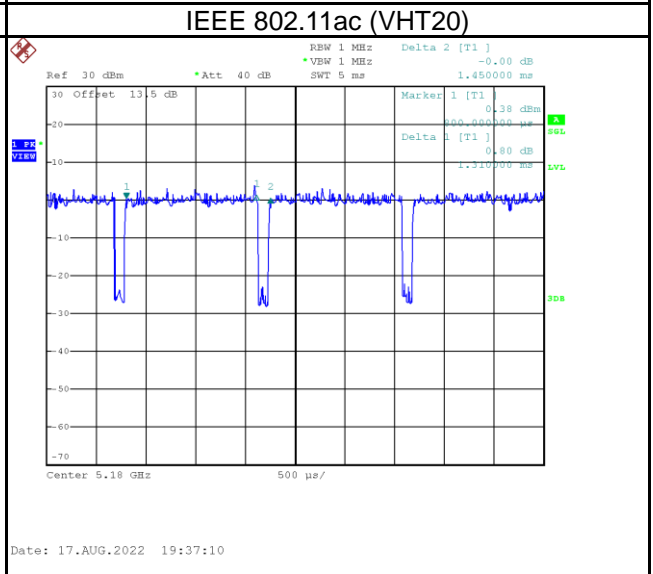
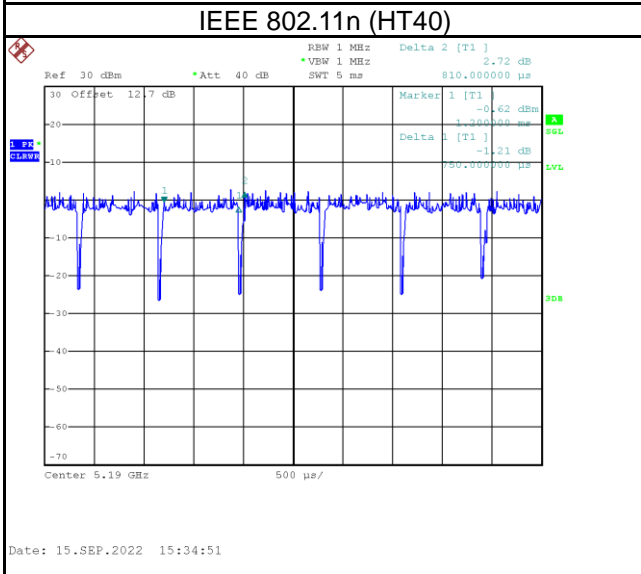
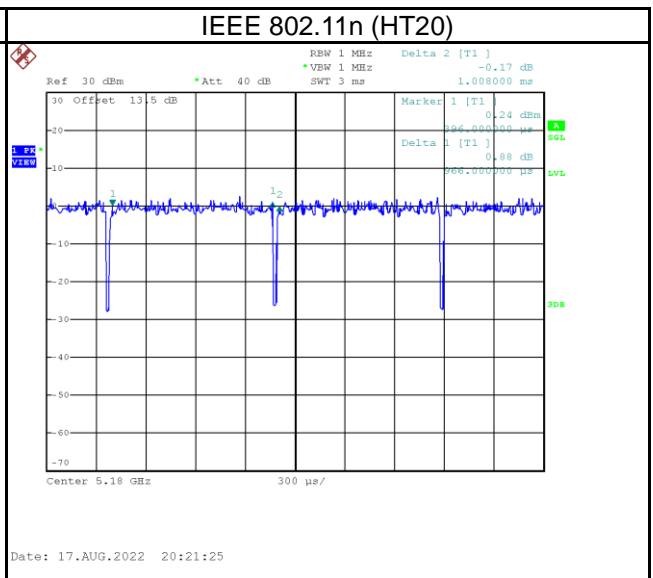
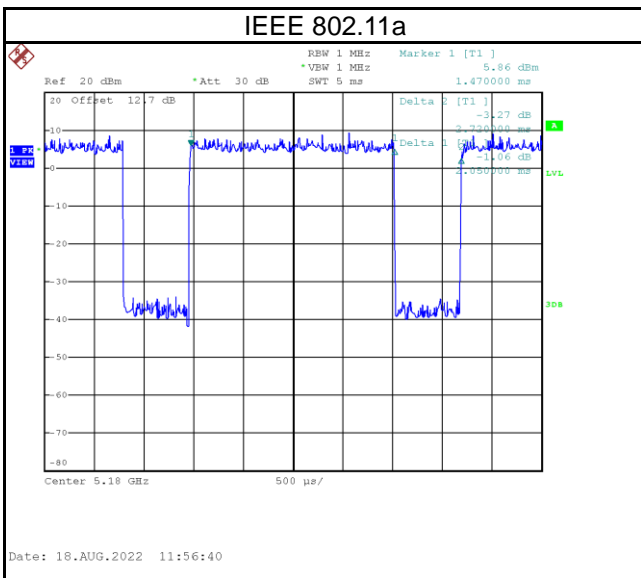

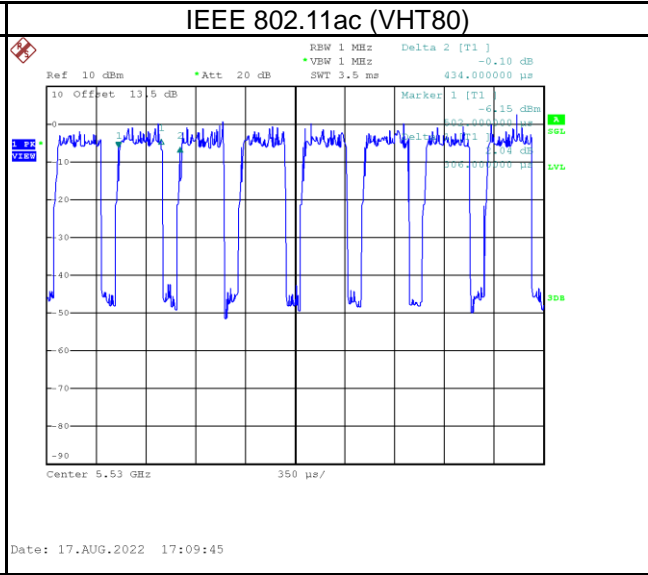
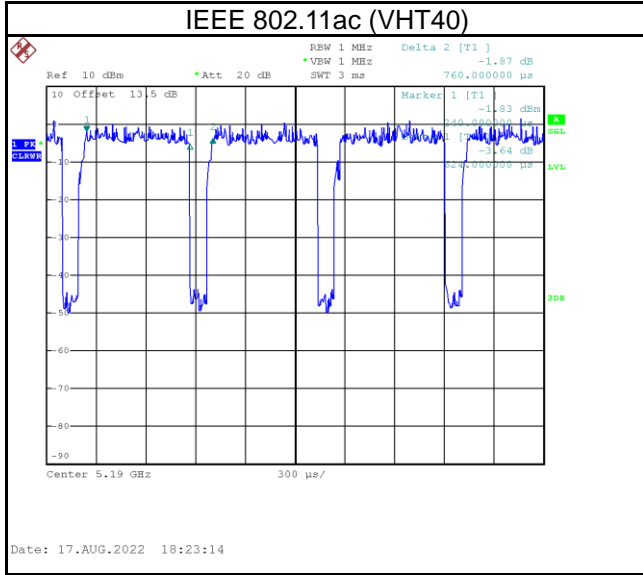

2 GENERAL INFORMATION

2.1 DESCRIPTION OF EUT

Equipment	portable monitor
Model Name	RICOH Portable Monitor 150BW, RICOH Light Monitor 150BW
Brand Name	RICOH
Model Difference	Different model distribute to different area.
Power Source	DC voltage supplied from Type-C port or battery.
Power Rating	IP: DC 5V or 9 V or 15V --- 3 A or 20V --- 2.25A Max.
Products Covered	1 * Type-C Cable
Operation Band	UNII-1: 5150 MHz to 5250 MHz UNII-2A: 5250 MHz to 5350 MHz UNII-2C: 5470 MHz to 5725 MHz
Operation Frequency	UNII-1: 5180 MHz to 5240 MHz UNII-2A: 5260 MHz to 5320 MHz UNII-2C: 5500 MHz to 5720 MHz
Modulation Technology	OFDM
Transfer Rate	802.11a: 54/48/36/24/18/12/9/6 Mbps 802.11n: Up to 300 Mbps 802.11ac: Up to 866.7 Mbps
Output Power Max. for UNII-1	IEEE 802.11a: 12.38 dBm (0.0173 W) IEEE 802.11n (HT20): 12.32 dBm (0.0171 W) IEEE 802.11n (HT40): 12.67 dBm (0.0185 W) IEEE 802.11ac (VHT20): 12.44 dBm (0.0175 W) IEEE 802.11ac (VHT40): 12.71 dBm (0.0187 W) IEEE 802.11ac (VHT80): 12.83 dBm (0.0192 W)
Output Power Max. for UNII-2A	IEEE 802.11a: 12.66 dBm (0.0184 W) IEEE 802.11n (HT20): 12.43 dBm (0.0175 W) IEEE 802.11n (HT40): 12.12 dBm (0.0163 W) IEEE 802.11ac (VHT20): 12.60 dBm (0.0182 W) IEEE 802.11ac (VHT40): 12.90 dBm (0.0195 W) IEEE 802.11ac (VHT80): 12.90 dBm (0.0195 W)
Output Power Max. for UNII-2C	IEEE 802.11a: 12.76 dBm (0.0189 W) IEEE 802.11n (HT20): 12.70 dBm (0.0186 W) IEEE 802.11n (HT40): 12.83 dBm (0.0192 W) IEEE 802.11ac (VHT20): 12.62 dBm (0.0183 W) IEEE 802.11ac (VHT40): 12.88 dBm (0.0194 W) IEEE 802.11ac (VHT80): 12.92 dBm (0.0196 W)
Maximum Output Power for Straddle Channel	IEEE 802.11a: 12.22 dBm (0.0167 W) IEEE 802.11n (HT20): 12.05 dBm (0.0160 W) IEEE 802.11n (HT40): 11.90 dBm (0.0155 W) IEEE 802.11ac (VHT20): 11.89 dBm (0.0154 W) IEEE 802.11ac (VHT40): 11.95 dBm (0.0157 W) IEEE 802.11ac (VHT80): 12.24 dBm (0.0167 W)
Test Model	RICOH Portable Monitor 150BW
Sample Status	Engineering Sample
EUT Modification(s)	N/A

NOTE:

(1) The above EUT information is declared by manufacturer and for more detailed features description, please refers to the manufacturer's specifications or user's manual.

(2) Channel List:

IEEE 802.11a IEEE 802.11n (HT20) IEEE 802.11ac (VHT20)		IEEE 802.11n (HT40) IEEE 802.11ac (VHT40)		IEEE 802.11ac (VHT80)	
UNII-1		UNII-1		UNII-1	
Channel	Frequency (MHz)	Channel	Frequency (MHz)	Channel	Frequency (MHz)
36	5180	38	5190	42	5210
40	5200	46	5230		
44	5220				
48	5240				

IEEE 802.11a IEEE 802.11n (HT20) IEEE 802.11ac (VHT20)		IEEE 802.11n (HT40) IEEE 802.11ac (VHT40)		IEEE 802.11ac (VHT80)	
UNII-2A		UNII-2A		UNII-2A	
Channel	Frequency (MHz)	Channel	Frequency (MHz)	Channel	Frequency (MHz)
52	5260	54	5270	58	5290
56	5280	62	5310		
60	5300				
64	5320				

IEEE 802.11a IEEE 802.11n (HT20) IEEE 802.11ac (VHT20)		IEEE 802.11n (HT40) IEEE 802.11ac (VHT40)		IEEE 802.11ac (VHT80)	
UNII-2C		UNII-2C		UNII-2C	
Channel	Frequency (MHz)	Channel	Frequency (MHz)	Channel	Frequency (MHz)
100	5500	102	5510	106	5530
104	5520	110	5550	138	5690
108	5540	118	5590		
112	5560	134	5670		
116	5580	142	5710		
132	5660				
136	5680				
140	5700				
144	5720				

(3) Table for Filed Antenna:

Ant.	Manufacturer	Part number	Type	Connector	Frequency (MHz)	Gain (dBi)
Main	Pulse	TZ22940	PIFA	NGFF	5150-5250	2.95
					5250-5350	2.89
					5470-5725	2.82
Aux	Pulse	TZ22950	PIFA	NGFF	5150-5250	2.97
					5250-5350	2.28
					5470-5725	2.52

Note:

- 1) The EUT incorporates a MIMO function. Physically, the EUT provides two completed transmitters and receivers (2T2R).

5150 MHz -5250 MHz, 5250 MHz -5350 MHz:

$$\text{Directional gain} = 10 \cdot \log\{[10^{(G1/20)} + 10^{(G2/20)} + \dots + 10^{(Gn/20)}]^2 / NANT\} = 5.97 \text{ dBi} < 6 \text{ dBi}$$

5740 MHz -5725 MHz:

$$\text{Directional Gain} = 10 \cdot \log\{[10^{(G1/20)} + 10^{(G2/20)} + \dots + 10^{(Gn/20)}]^2 / NANT\} = 5.68 \text{ dBi} < 6 \text{ dBi}$$

- (4) The above Antenna information are derived from the antenna data sheet provided by manufacturer and for more detailed features description, please refer to the manufacturer's specifications, the laboratory shall not be held responsible.

(5) Operating Mode and Antenna Configuration

TX Mode	Operating Mode	2TX
	IEEE 802.11a	V (Main or Aux or Main + Aux)
	IEEE 802.11n (HT20)	V (Main or Aux or Main + Aux)
	IEEE 802.11n (HT40)	V (Main or Aux or Main + Aux)
	IEEE 802.11ac (VHT20)	V (Main or Aux or Main + Aux)
	IEEE 802.11ac (VHT40)	V (Main or Aux or Main + Aux)
	IEEE 802.11ac (VHT80)	V (Main or Aux or Main + Aux)

2.2 TEST MODES

Test Items	Test mode	Channel	Note
AC power line conducted emissions	Normal/Idle	-	-
Transmitter Radiated Emissions (below 1GHz)	TX Mode_IEEE 802.11ac (VHT20)	140	-
Transmitter Radiated Emissions (above 1GHz)	TX Mode_IEEE 802.11a	36/48, 52/64	Bandedge
	TX Mode_IEEE 802.11ac (VHT20)	100/140	
	TX Mode_IEEE 802.11ac (VHT40)	38/46, 54/62 102/134	
	TX Mode_IEEE 802.11ac (VHT80)	42, 58 106/122	
	TX Mode_IEEE 802.11a	36/40/48 52/60/64	Harmonic
	TX Mode_IEEE 802.11ac (VHT20)	100/116/140/144	
	TX Mode_IEEE 802.11ac (VHT40)	38/46/ 54/62 102/110/134/142	
	TX Mode_IEEE 802.11ac (VHT80)	42, 58 106/138	
Bandwidth	TX Mode_IEEE 802.11a	36/40/48 52/60/64	-
	TX Mode_IEEE 802.11ac (VHT20)	100/116/140	
	TX Mode_IEEE 802.11ac (VHT40)	38/46/ 54/62 102/110/134	
	TX Mode_IEEE 802.11ac (VHT80)	42, 58 106	
Output Power	TX Mode_IEEE 802.11a	36/40/48 52/60/64	-
	TX Mode_IEEE 802.11n (HT20) TX Mode_IEEE 802.11ac (VHT20)	100/116/140/144	
	TX Mode_IEEE 802.11n (HT40) TX Mode_IEEE 802.11ac (VHT40)	38/46/ 54/62 102/110/134/142	
	TX Mode_IEEE 802.11ac (VHT80)	42, 58 106/138	
Power Spectral Density	TX Mode_IEEE 802.11a	36/40/48 52/60/64	-
	TX Mode_IEEE 802.11ac (VHT20)	100/116/140/144	
	TX Mode_IEEE 802.11ac (VHT40)	38/46/ 54/62 102/110/134/142	
	TX Mode_IEEE 802.11ac (VHT80)	42, 58 106/138	

NOTE:

- (1) For radiated emission band edge test, both Vertical and Horizontal are evaluated, but only the worst case (Vertical) is recorded.
- (2) All X, Y and Z axes are evaluated, but only the worst case (Y axis) is recorded.

2.3 BLOCK DIAGRAM SHOWING THE CONFIGURATION OF SYSTEM TESTED

Equipment letters and Cable numbers refer to item numbers described in the tables of clause 2.4.

AC power line conducted emissions

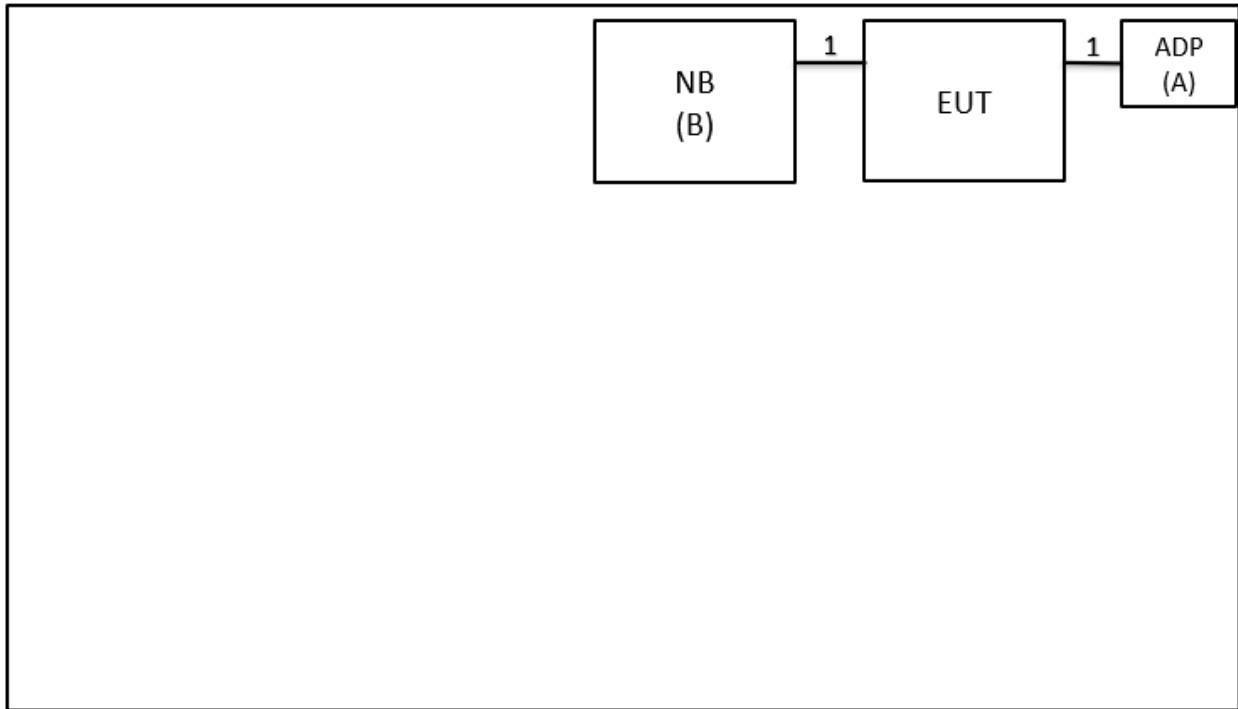

Radiated Emissions

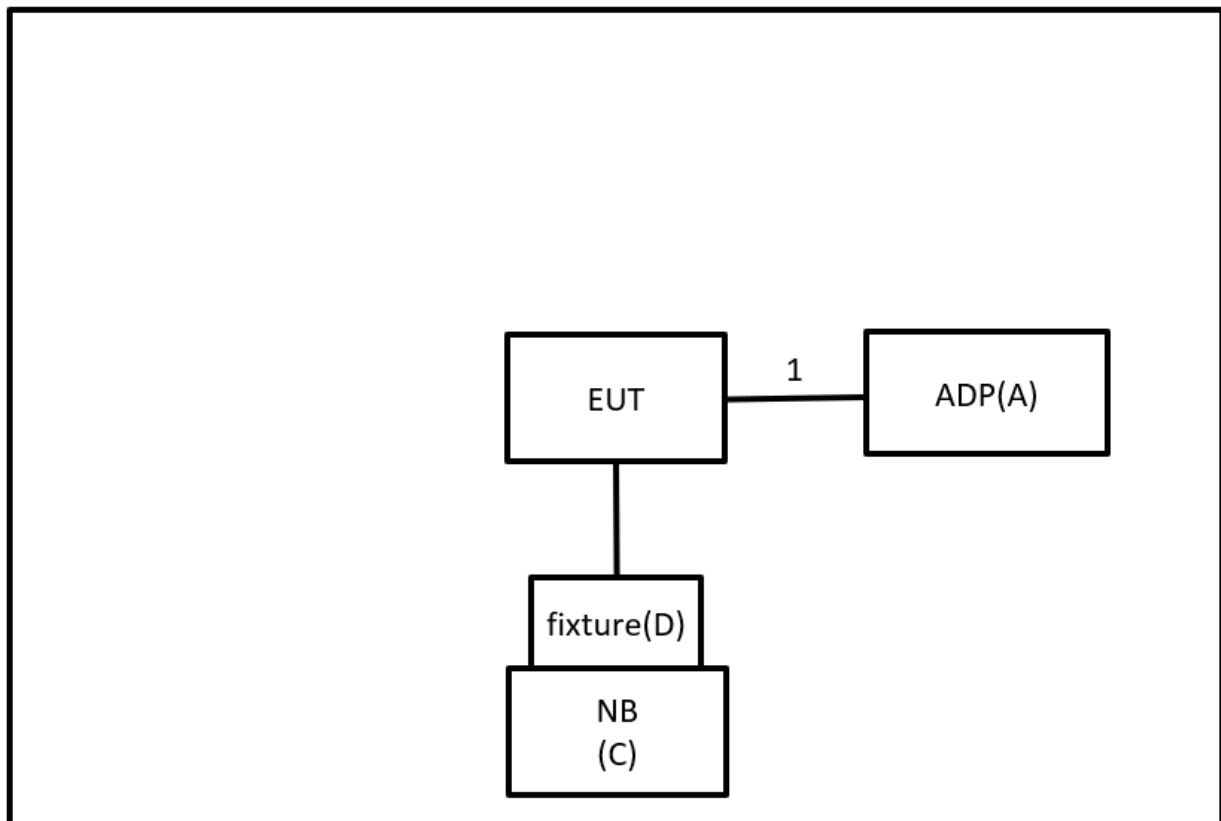

2.4 SUPPORT UNITS

Item	Equipment	Brand	Model No.	Series No.	Remarks
A	Adapter	iBRIDGE	IBC005	N/A	Furnished by test lab.
B	NB	HP	240 G5	N/A	Furnished by test lab.
C	NB	Asus	B500-P45VA-014 1A3230M	N/A	Furnished by test lab.
D	Fixture	Waveshare	PL2303	N/A	Furnished by test lab.

Item	Shielded	Ferrite Core	Length	Cable Type	Remarks
1	N/A	N/A	1m	USB-C Cable	Supplied by test requester

3 AC POWER LINE CONDUCTED EMISSIONS TEST

3.1 LIMIT

Frequency (MHz)	Limit (dB μ V)	
	Quasi-peak	Average
0.15 - 0.5	66 - 56 *	56 - 46 *
0.50 - 5.0	56	46
5.0 - 30.0	60	50

NOTE:

- (1) The tighter limit applies at the band edges.
- (2) The limit of " * " marked band means the limitation decreases linearly with the logarithm of the frequency in the range.
- (3) The test result calculated as following:
 Measurement Value = Reading Level + Correct Factor
 Correct Factor = Insertion Loss + Cable Loss + Attenuator Factor (if use)
 Margin Level = Measurement Value – Limit Value
 Calculation example:

Reading Level		Correct Factor		Measurement Value
38.22	+	3.45	=	41.67

Measurement Value		Limit Value		Margin Level
41.67	-	60	=	-18.33

The following table is the setting of the receiver.

Receiver Parameter	Setting
Attenuation	10 dB
Start Frequency	0.15 MHz
Stop Frequency	30 MHz
IF Bandwidth	9 KHz

3.2 TEST PROCEDURE

- a. The EUT was placed 0.8 m above the horizontal ground plane with the EUT being connected to the power mains through a line impedance stabilization network (LISN).
 All other support equipment were powered from an additional LISN(s).
 The LISN provides 50 Ohm/50uH of impedance for the measuring instrument.
- b. Interconnecting cables that hang closer than 40 cm to the ground plane shall be folded back and forth in the center forming a bundle to keep the cable above 40 cm.
- c. Excess I/O cables that are not connected to a peripheral shall be bundled in the center.
 The end of the cable will be terminated, using the correct terminating impedance.
 The overall length shall not exceed 1 m.
- d. The LISN is spaced at least 80 cm from the nearest part of the EUT chassis.
- e. For the actual test configuration, please refer to the related Item – EUT TEST PHOTO.

NOTE:

- (1) In the results, each reading is marked as Peak, QP or AVG per the detector used.
 BW=9 kHz (6 dB Bandwidth)
- (2) All readings are Peak unless otherwise stated QP or AVG in column of Note. Both the QP and the AVG readings must be less than the limit for compliance.

3.3 DEVIATION FROM TEST STANDARD

No deviation.

3.4 TEST SETUP

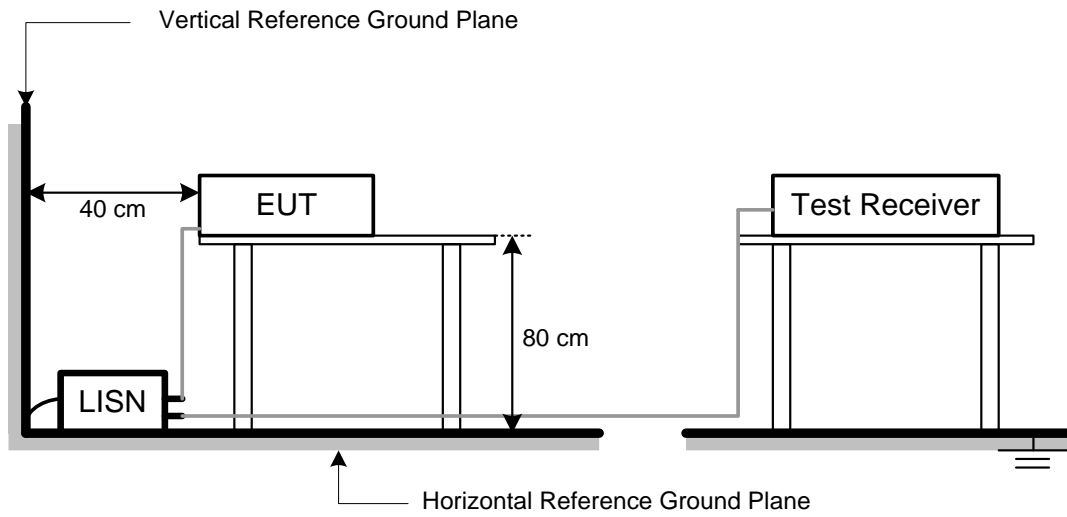

3.5 TEST RESULT

Please refer to the APPENDIX A.

4 RADIATED EMISSIONS TEST

4.1 LIMIT

In case the emission fall within the restricted band specified on 15.205, then the 15.209 limit in the table below has to be followed.

LIMITS OF RADIATED EMISSIONS MEASUREMENT (9 kHz to 1000 MHz)

Frequency (MHz)	Field Strength (microvolts/meter)	Measurement Distance (meters)
0.009~0.490	2400/F(KHz)	300
0.490~1.705	24000/F(KHz)	30
1.705~30.0	30	30
30~88	100	3
88~216	150	3
216~960	200	3
960~1000	500	3

LIMITS OF UNWANTED EMISSION OUT OF THE RESTRICTED BANDS

Frequency (MHz)	EIRP Limit (dBm)	Equivalent Field Strength at 3m (dBµV/m)
5150-5250	-27	68.3
5250-5350	-27	68.3
5470-5725	-27	68.3
5725-5850	-27 (NOTE 2)	68.3
	10 (NOTE 2)	105.3
	15.6 (NOTE 2)	110.9
	27 (NOTE 2)	122.3

NOTE:

(1) The following formula is used to convert the equipment isotropic radiated power (eirp) to field strength:

$$E = \frac{1000000\sqrt{30P}}{3} \mu\text{V/m, where P is the eirp (Watts)}$$

(2) According to FCC 16-24, All emissions shall be limited to a level of -27 dBm/MHz at 75 MHz or more above or below the band edge increasing linearly to 10 dBm/MHz at 25 MHz above or below the band edge, and from 25 MHz above or below the band edge increasing linearly to a level of 15.6 dBm/MHz at 5 MHz above or below the band edge, and from 5 MHz above or below the band edge increasing linearly to a level of 27 dBm/MHz at the band edge.

(3) The test result calculated as following:

Measurement Value = Reading Level + Correct Factor

Correct Factor = Antenna Factor + Cable Loss - Amplifier Gain(if use)

Margin Level = Measurement Value - Limit Value

Calculation example:

Reading Level		Correct Factor		Measurement Value
36.23	+	-11.97	=	24.26

Measurement Value		Limit Value		Margin Level
24.26	-	40	=	-15.74

Spectrum Parameter	Setting
Attenuation	Auto
Start Frequency	1000 MHz
Stop Frequency	10th carrier harmonic
RBW / VBW (Emission in restricted band)	1MHz / 3MHz for Peak, 1MHz / 1/T for Average

Spectrum Parameter	Setting
Attenuation	Auto
Start ~ Stop Frequency	9KHz~90KHz for PK/AVG detector
Start ~ Stop Frequency	90KHz~110KHz for QP detector
Start ~ Stop Frequency	110KHz~490KHz for PK/AVG detector
Start ~ Stop Frequency	490KHz~30MHz for QP detector
Start ~ Stop Frequency	30MHz~1000MHz for QP detector

4.2 TEST PROCEDURE

- a. The measuring distance of 3 m shall be used for measurements. The EUT was placed on the top of a rotating table 0.8 meter above the ground at a 3 meter semi-anechoic chamber. The table was rotated 360 degrees to determine the position of the highest radiation.(below 1GHz)
- b. The measuring distance of 3 m shall be used for measurements. The EUT was placed on the top of a rotating table 1.5 meter above the ground at a 3 meter semi-anechoic chamber. The table was rotated 360 degrees to determine the position of the highest radiation.(above 1GHz)
- c. The height of the equipment or of the substitution antenna shall be 0.8 m or 1.5 m, the height of the test antenna shall vary between 1 m to 4 m. Both horizontal and vertical polarizations of the antenna are set to make the measurement.
- d. For each suspected emission, the EUT was arranged to its worst case and then the antenna was tuned to heights find the maximum reading (used Bore sight function).
- e. The receiver system was set to peak and average detect function and specified bandwidth with maximum hold mode when the test frequency is above 1GHz.
- f. The initial step in collecting radiated emission data is a receiver peak detector mode pre-scanning the measurement frequency range. Significant peaks are then marked and then Quasi Peak detector mode re-measured.
- g. All readings are Peak unless otherwise stated QP in column of Note. Peak denotes that the Peak reading compliance with the QP Limits and then QP Mode measurement didn't perform. (below 1GHz)
- h. All readings are Peak Mode value unless otherwise stated AVG in column of Note. If the Peak Mode Measured value compliance with the Peak Limits and lower than AVG Limits, the EUT shall be deemed to meet both Peak & AVG Limits and then only Peak Mode was measured, but AVG Mode didn't perform. (above 1GHz)
- i. For the actual test configuration, please refer to the related Item – EUT TEST PHOTO.

4.3 DEVIATION FROM TEST STANDARD

No deviation.

4.4 TEST SETUP

30 MHz to 1 GHz

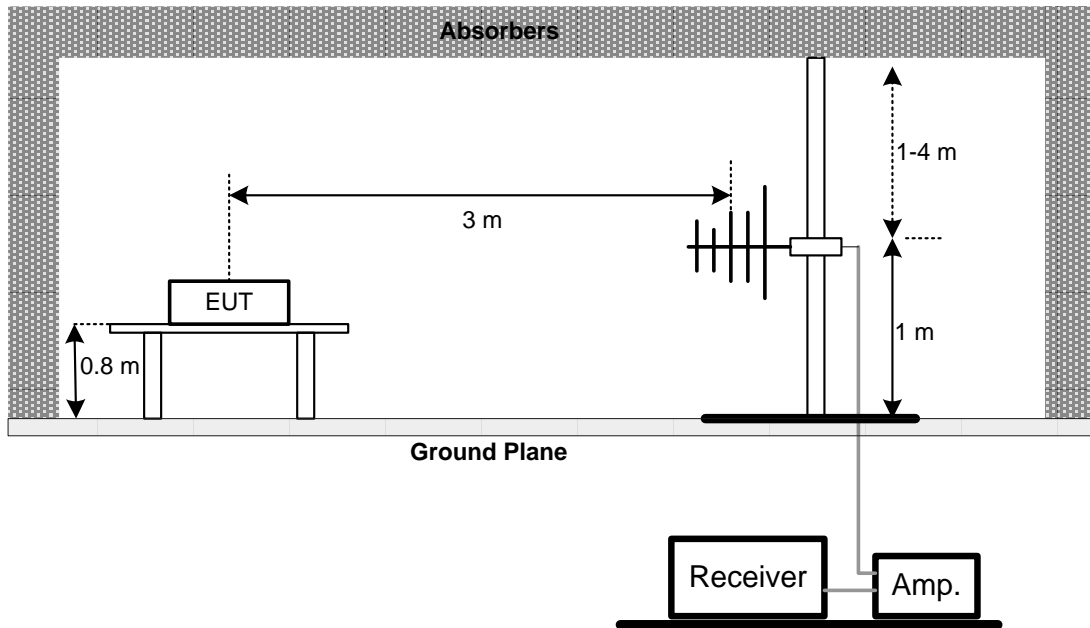

Above 1 GHz

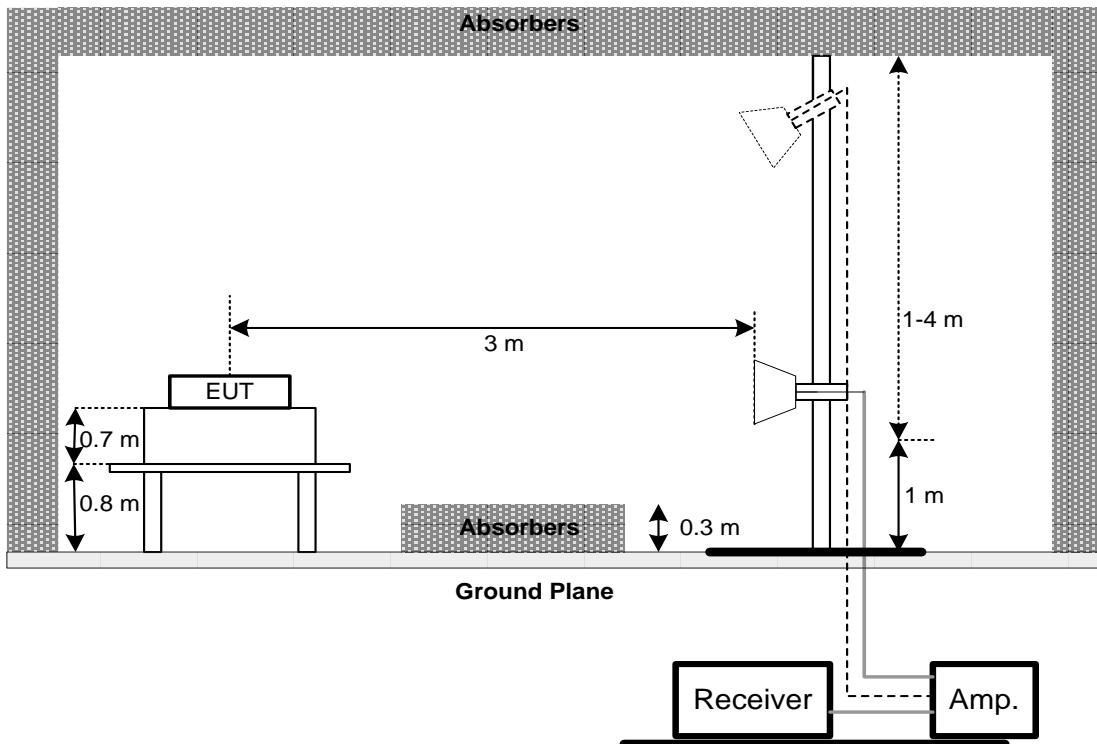

4.5 EUT OPERATING CONDITIONS

The EUT was programmed to be in continuously transmitting mode.

4.6 TEST RESULT – BELOW 30 MHZ

There were no emissions found below 30 MHz within 20 dB of the limit.

4.7 TEST RESULT – 30 MHZ TO 1 GHZ

Please refer to the APPENDIX B.

4.8 TEST RESULT – ABOVE 1 GHZ

Please refer to the APPENDIX C.

NOTE:

- (1) No limit: This is fundamental signal, the judgment is not applicable.
For fundamental signal judgment was referred to Peak output test.

5 BANDWIDTH TEST

5.1 LIMIT

FCC Part15, Subpart E (15.407)		
Section	Test Item	Frequency Range (MHz)
15.407(a)	26 dB Bandwidth	5150-5250
		5250-5350
		5470-5725
	Minimum 500 kHz 6 dB Bandwidth	5725-5850

5.2 TEST PROCEDURE

- a. The EUT was directly connected to the spectrum analyzer and antenna output port as show in the block diagram below.
- b. Spectrum Setting:

Spectrum Parameter	Setting
Attenuation	Auto
Span Frequency	> 26 dB Bandwidth
RBW	300 kHz(Bandwidth 20 MHz) 1 MHz(Bandwidth 40 MHz and 80 MHz)
VBW	1 MHz(Bandwidth 20 MHz) 3 MHz(Bandwidth 40 MHz and 80 MHz)
Detector	Peak
Trace	Max Hold
Sweep Time	Auto

5.3 DEVIATION FROM TEST STANDARD

No deviation.

5.4 TEST SETUP

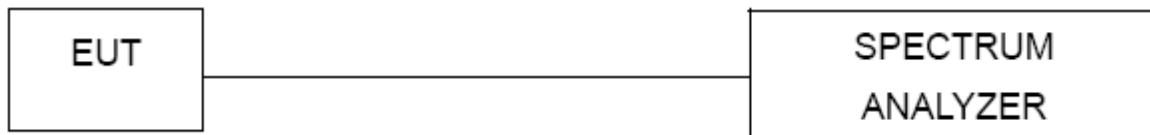

5.5 EUT OPERATING CONDITIONS

The EUT was programmed to be in continuously transmitting mode.

5.6 TEST RESULT

Please refer to the APPENDIX D.

6 OUTPUT POWER TEST

6.1 LIMIT

FCC Part15, Subpart E (15.407)			
Section	Test Item	Limit	Frequency Range (MHz)
15.407(a)	Maximum Output Power	Fixed:1 Watt (30 dBm) Mobile and portable: 250 mW (24 dBm)	5150-5250
		250 mW (24 dBm)	5250-5350
		1 Watt (30dBm)	5470-5725 5725-5850

Note: The maximum e.i.r.p at any elevation angle above 30 degrees as measured from the horizon must not exceed 125 mW(21 dBm).

6.2 TEST PROCEDURE

- a. The EUT was directly connected to the power meter and antenna output port as show in the block diagram below.
- b. The maximum peak conducted output power was performed in accordance with method of clause E. 3. a) FCC KDB 789033 D02 General UNII Test Procedures New Rules v02r01.
 - a)Method PM (Measurement using an RF average power meter):
 - (i) Measurements may be performed using a wideband RF power meter with a thermocouple detector or equivalent if all of the following conditions are satisfied
The EUT is configured to transmit continuously or to transmit with a constant duty cycle.
At all times when the EUT is transmitting, it must be transmitting at its maximum power control level.
The integration period of the power meter exceeds the repetition period of the transmitted signal by at least a factor of five.
 - (ii) If the transmitter does not transmit continuously, measure the duty cycle, x, of the transmitter output signal as described in II.B.
 - (iii) Measure the average power of the transmitter. This measurement is an average over both the on and off periods of the transmitter.
 - (iv) Adjust the measurement in dBm by adding $10 \log (1/x)$ where x is the duty cycle (e.g., $10 \log (1/0.25)$ if the duty cycle is 25%).

6.3 DEVIATION FROM TEST STANDARD

No deviation.

6.4 TEST SETUP

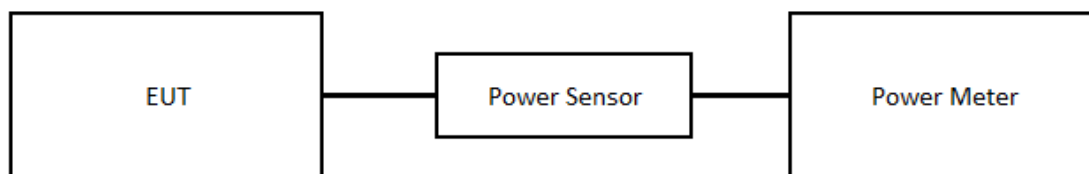

6.5 EUT OPERATING CONDITIONS

The EUT was programmed to be in continuously transmitting mode.

6.6 TEST RESULT

Please refer to the APPENDIX E.

7 POWER SPECTRAL DENSITY

7.1 LIMIT

FCC Part15, Subpart E (15.407)			
Section	Test Item	Limit	Frequency Range (MHz)
15.407(a)	Power Spectral Density	Other than Mobile and portable: 17 dBm/MHz	5150-5250
		Mobile and portable: 11 dBm/MHz	
		11 dBm/MHz	5250-5350
		30 dBm/500 kHz	5470-5725
			5725-5850

7.2 TEST PROCEDURE

- a. The EUT was directly connected to the spectrum analyzer and antenna output port as show in the block diagram below.
- b. Spectrum Setting:

Spectrum Parameter	Setting
Attenuation	Auto
Span Frequency	Encompass the entire emissions bandwidth (EBW) of the signal
RBW	= 1 MHz
VBW	≥ 3 MHz
Detector	RMS
Trace	Max Hold
Sweep Time	Auto

7.3 DEVIATION FROM TEST STANDARD

No deviation.

7.4 TEST SETUP



7.5 EUT OPERATING CONDITIONS

The EUT was programmed to be in continuously transmitting mode.

7.6 TEST RESULT

Please refer to the APPENDIX F.

8 LIST OF MEASURING EQUIPMENTS

AC Power Line Conducted Emissions						
Item	Kind of Equipment	Manufacturer	Type No.	Serial No.	Calibrated Date	Calibrated Until
1	TWO-LINE V-NETWORK	R&S	ENV216	101051	2022/6/15	2023/6/14
2	Test Cable	EMCI	EMCRG58-BM-B M-9000	210501	2022/5/2	2023/5/1
3	EMI Test Receiver	R&S	ESR 7	101433	2021/11/24	2022/11/23
4	Measurement Software	EZ	EZ_EM C (Version NB-03A1-01)	N/A	N/A	N/A

Radiated Emissions						
Item	Kind of Equipment	Manufacturer	Type No.	Serial No.	Calibrated Date	Calibrated Until
1	Preamplifier	EMCI	EMC330N	980850	2021/9/23	2022/9/22
2	Preamplifier	EMCI	EMC118A45SE	980819	2022/3/8	2023/3/7
3	Preamplifier	EMCI	EMC184045SE	980882	2022/2/9	2023/2/8
4	Preamplifier	EMCI	EMC001340	980555	2022/4/6	2023/4/5
5	Test Cable	EMCI	EMC104-SM-SM-1000	220319	2022/3/15	2023/3/14
6	Test Cable	EMCI	EMC104-SM-SM-3000	220322	2022/3/15	2023/3/14
7	Test Cable	EMCI	EMC104-SM-SM-7000	220324	2022/3/15	2023/3/14
8	EXA Signal Analyzer	keysight	N9020A	MY57120120	2022/3/7	2023/3/6
9	Loop Ant	Electro-Metrics	EMCI-LPA600	274	2022/6/16	2023/6/15
10	Horn Antenna	RFSPIN	DRH18-E	211202A18EN	2022/5/18	2023/5/17
11	Horn Ant	Schwarzbeck	BBHA 9170D	1136	2022/5/18	2023/5/17
12	Log-bicon Antenna	Schwarzbeck	VULB9168	1369	2022/5/20	2023/5/19
13	6dB Attenuator	EMCI	EMCI-N-6-06	AT-N0625	2022/5/20	2023/5/19
14	Test Cable	EMCI	EMC101G-KM-K M-3000	220329	2022/3/15	2023/3/14
15	Test Cable	EMCI	EMC102-KM-KM-1000	220327	2022/3/15	2023/3/14
16	Measurement Software	EZ	EZ_EM C (Version NB-03A1-01)	N/A	N/A	N/A

Bandwidth						
Item	Kind of Equipment	Manufacturer	Type No.	Serial No.	Calibrated Date	Calibrated Until
1	Spectrum Analyzer	R&S	FSP 30	100854	2022/4/12	2023/4/11

Output Power						
Item	Kind of Equipment	Manufacturer	Type No.	Serial No.	Calibrated Date	Calibrated Until
1	Power Meter	Anritsu	ML2495A	1128008	2022/6/1	2023/5/31
2	Power Sensor	Anritsu	MA2411B	1126001	2022/6/1	2023/5/31

Power Spectral Density						
Item	Kind of Equipment	Manufacturer	Type No.	Serial No.	Calibrated Date	Calibrated Until
1	Spectrum Analyzer	R&S	FSP 30	100854	2022/4/12	2023/4/11

Remark: "N/A" denotes no model name, no serial no. or no calibration specified.
All calibration period of equipment list is one year.

9 EUT TEST PHOTO

Please refer to document Appendix No.: TP-2207T020-FCCP-1 (APPENDIX-TEST PHOTOS).

10 EUT PHOTOS

Please refer to document Appendix No.: EP-2207T020-1 (APPENDIX-EUT PHOTOS).

APPENDIX A AC POWER LINE CONDUCTED EMISSIONS

Test Mode	Normal	Tested Date	2022/8/17
Test Frequency	-	Phase	Line

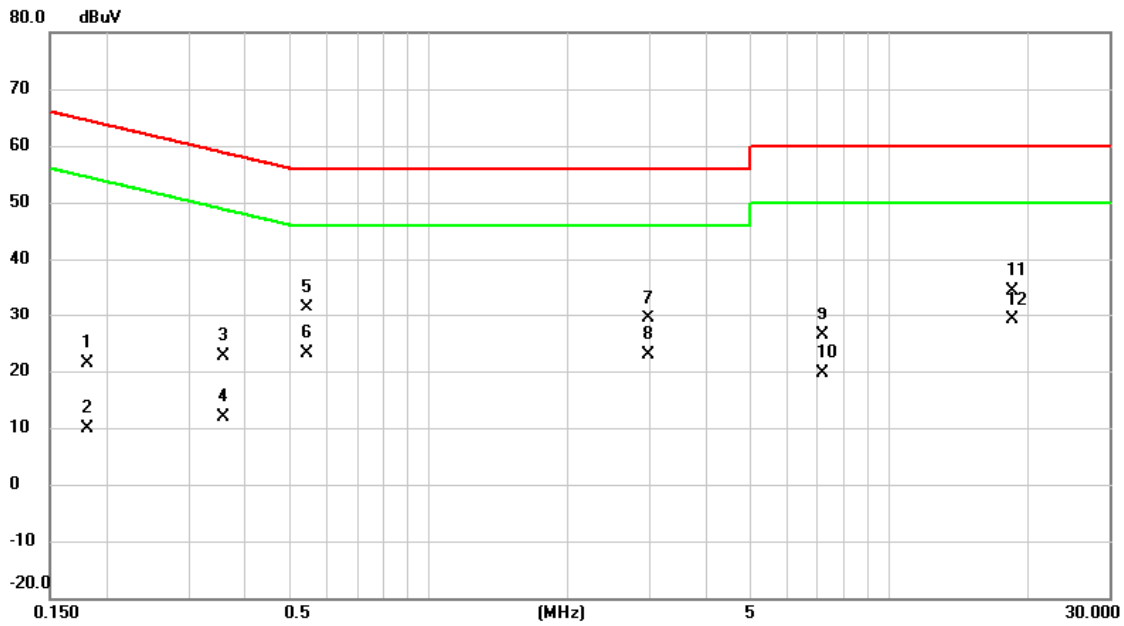

No.	Mk.	Freq. MHz	Reading Level dBuV	Correct Factor dB	Measure- ment dBuV	Limit dBuV	Margin dB	Detector	Comment
1	X	0.1815	11.79	9.63	21.42	64.42	-43.00	QP	
2	X	0.1815	0.28	9.63	9.91	54.42	-44.51	AVG	
3	X	0.3592	13.06	9.62	22.68	58.75	-36.07	QP	
4	X	0.3592	2.35	9.62	11.97	48.75	-36.78	AVG	
5	X	0.5460	21.70	9.62	31.32	56.00	-24.68	QP	
6	X	0.5460	13.41	9.62	23.03	46.00	-22.97	AVG	
7	X	2.9917	19.67	9.72	29.39	56.00	-26.61	QP	
8	X	2.9917	13.15	9.72	22.87	46.00	-23.13	AVG	
9	X	7.1565	16.61	9.80	26.41	60.00	-33.59	QP	
10	X	7.1565	9.88	9.80	19.68	50.00	-30.32	AVG	
11	X	18.4267	24.58	9.83	34.41	60.00	-25.59	QP	
12	X	18.4267	19.19	9.83	29.02	50.00	-20.98	AVG	

REMARKS:

- (1) Measurement Value = Reading Level + Correct Factor.
- (2) Margin Level = Measurement Value - Limit Value.

Test Mode	Normal	Tested Date	2022/8/17
Test Frequency	-	Phase	Neutral

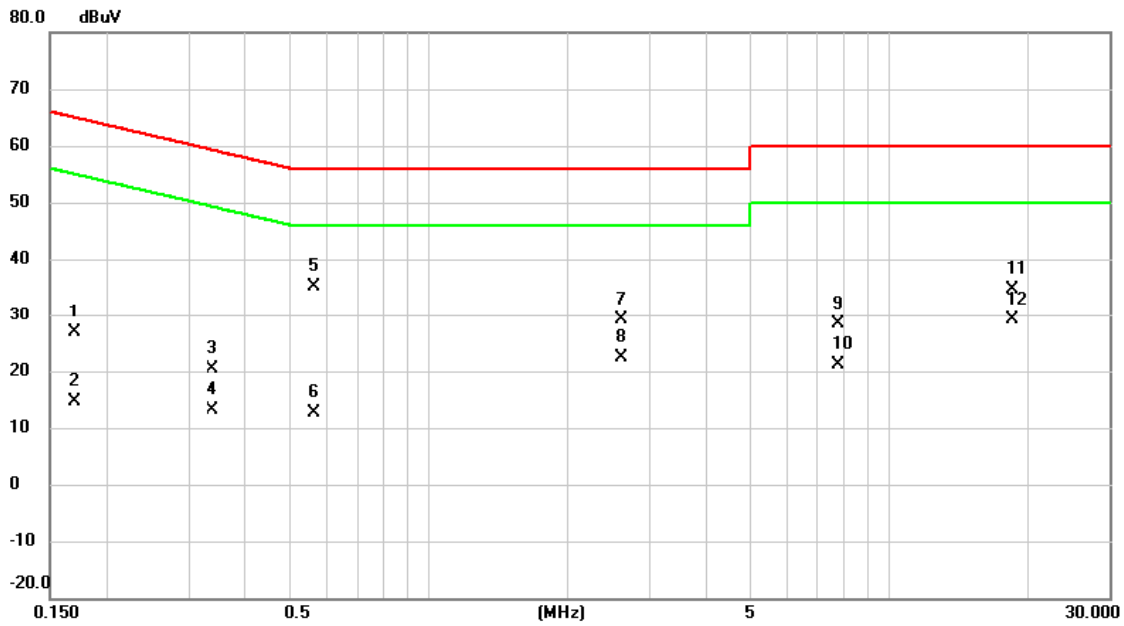

No.	Mk.	Freq. MHz	Reading Level dBuV	Correct Factor dB	Measure- ment dBuV	Limit dBuV	Margin dB	Detector	Comment
1		0.1703	17.29	9.63	26.92	64.95	-38.03	QP	
2		0.1703	5.10	9.63	14.73	54.95	-40.22	AVG	
3		0.3390	10.80	9.62	20.42	59.23	-38.81	QP	
4		0.3390	3.50	9.62	13.12	49.23	-36.11	AVG	
5	*	0.5640	25.51	9.62	35.13	56.00	-20.87	QP	
6		0.5640	3.08	9.62	12.70	46.00	-33.30	AVG	
7		2.6137	19.42	9.71	29.13	56.00	-26.87	QP	
8		2.6137	12.78	9.71	22.49	46.00	-23.51	AVG	
9		7.7775	18.53	9.83	28.36	60.00	-31.64	QP	
10		7.7775	11.20	9.83	21.03	50.00	-28.97	AVG	
11		18.5168	24.57	9.94	34.51	60.00	-25.49	QP	
12		18.5168	19.09	9.94	29.03	50.00	-20.97	AVG	

REMARKS:

- (1) Measurement Value = Reading Level + Correct Factor.
- (2) Margin Level = Measurement Value - Limit Value.

Test Mode	Idle	Tested Date	2022/8/17
Test Frequency	-	Phase	Line

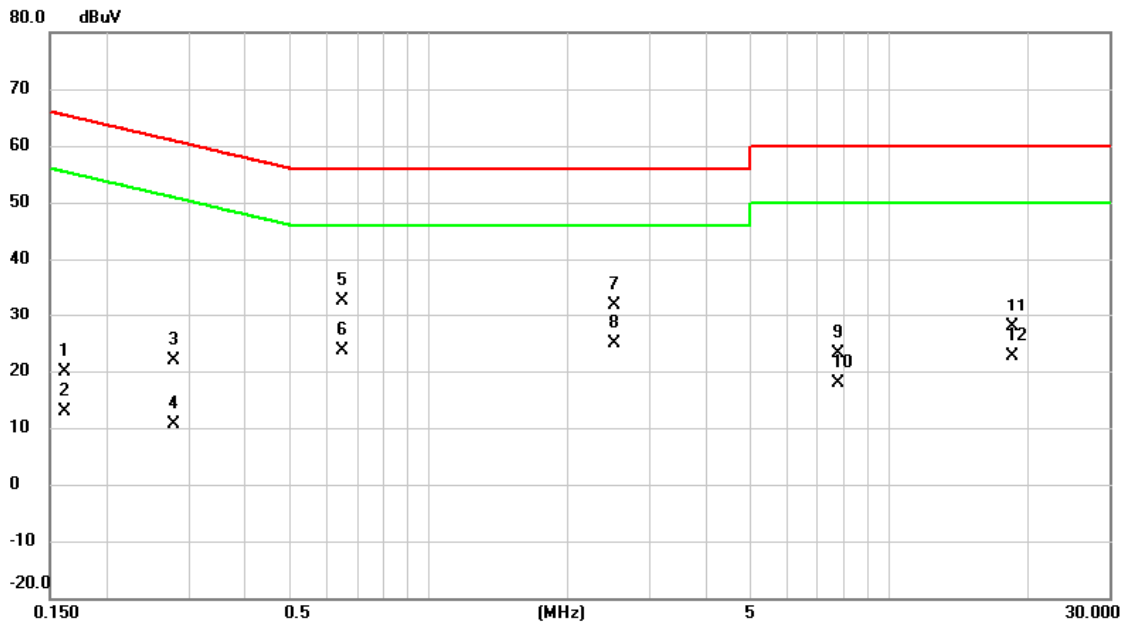

No.	Mk.	Freq. MHz	Reading Level dBuV	Correct Factor dB	Measure- ment dBuV	Limit dBuV	Margin dB	Detector	Comment
1		0.1613	10.31	9.63	19.94	65.40	-45.46	QP	
2		0.1613	3.16	9.63	12.79	55.40	-42.61	AVG	
3		0.2782	12.14	9.63	21.77	60.87	-39.10	QP	
4		0.2782	1.00	9.63	10.63	50.87	-40.24	AVG	
5		0.6495	22.98	9.63	32.61	56.00	-23.39	QP	
6		0.6495	13.98	9.63	23.61	46.00	-22.39	AVG	
7		2.5148	22.14	9.71	31.85	56.00	-24.15	QP	
8	*	2.5148	15.17	9.71	24.88	46.00	-21.12	AVG	
9		7.7730	13.30	9.81	23.11	60.00	-36.89	QP	
10		7.7730	8.10	9.81	17.91	50.00	-32.09	AVG	
11		18.4447	18.06	9.83	27.89	60.00	-32.11	QP	
12		18.4447	12.85	9.83	22.68	50.00	-27.32	AVG	

REMARKS:

- (1) Measurement Value = Reading Level + Correct Factor.
- (2) Margin Level = Measurement Value - Limit Value.

Test Mode	Idle	Tested Date	2022/8/17
Test Frequency	-	Phase	Neutral

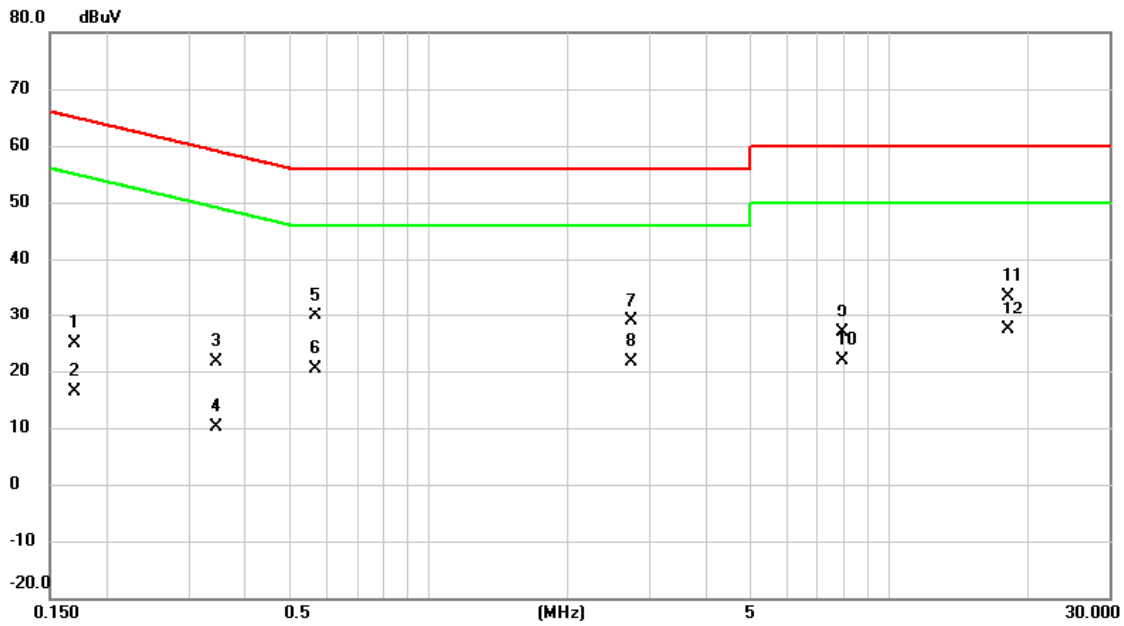

No.	Mk.	Freq. MHz	Reading Level dBuV	Correct Factor dB	Measure- ment dBuV	Limit dBuV	Margin dB	Detector	Comment
1		0.1702	15.37	9.63	25.00	64.95	-39.95	QP	
2		0.1702	6.75	9.63	16.38	54.95	-38.57	AVG	
3		0.3457	12.10	9.62	21.72	59.07	-37.35	QP	
4		0.3457	0.49	9.62	10.11	49.07	-38.96	AVG	
5		0.5662	20.23	9.62	29.85	56.00	-26.15	QP	
6		0.5662	10.88	9.62	20.50	46.00	-25.50	AVG	
7		2.7532	19.20	9.71	28.91	56.00	-27.09	QP	
8		2.7532	12.02	9.71	21.73	46.00	-24.27	AVG	
9		7.9057	16.99	9.83	26.82	60.00	-33.18	QP	
10		7.9057	12.15	9.83	21.98	50.00	-28.02	AVG	
11		18.1567	23.37	9.92	33.29	60.00	-26.71	QP	
12	*	18.1567	17.52	9.92	27.44	50.00	-22.56	AVG	

REMARKS:

- (1) Measurement Value = Reading Level + Correct Factor.
- (2) Margin Level = Measurement Value - Limit Value.

APPENDIX B RADIATED EMISSIONS - 30 MHZ TO 1 GHZ

Test Mode	IEEE 802.11ac (VHT20)	Test Date	2022/9/13
Test Frequency	5700MHz	Polarization	Vertical
Temp	25°C	Hum.	62%

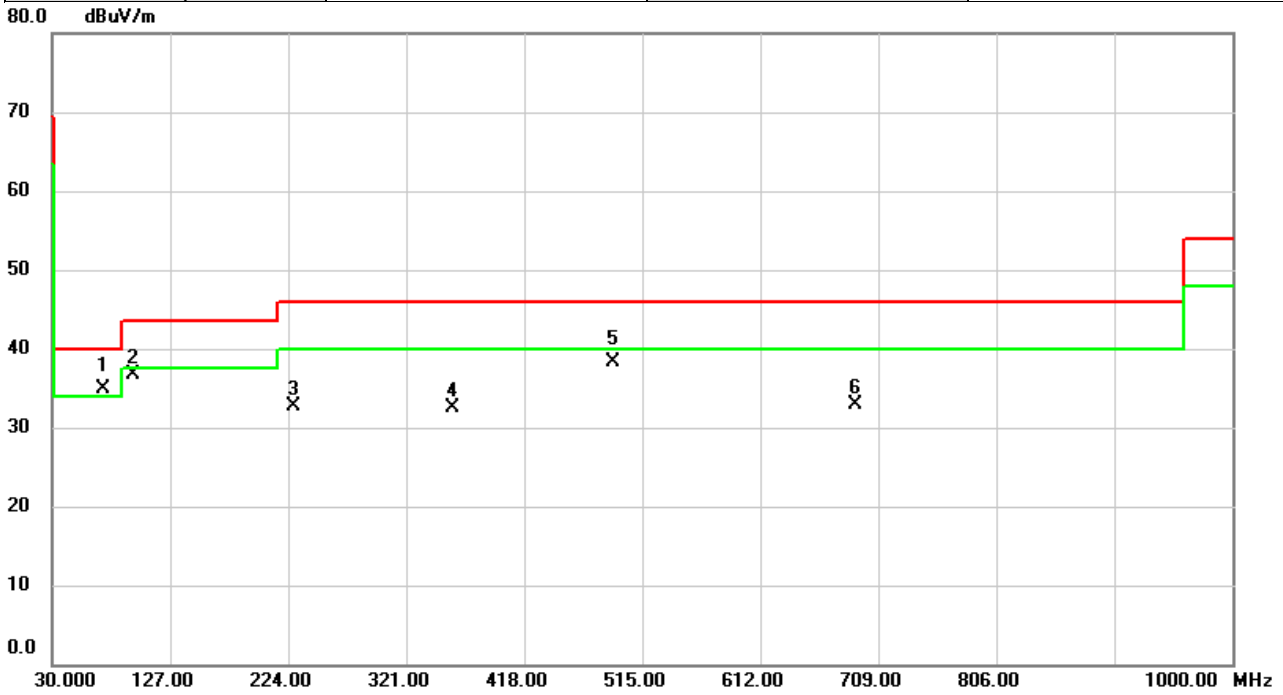

No.	Mk.	Freq.	Reading Level	Correct Factor	Measurement	Limit	Over	Detector	Comment
		MHz	dBuV	dB	dBuV/m	dBuV/m	dB		
1	*	71.9687	55.65	-20.76	34.89	40.00	-5.11	QP	
2		95.9600	58.81	-22.14	36.67	43.50	-6.83	peak	
3		229.0763	54.23	-21.50	32.73	46.00	-13.27	peak	
4		359.7677	49.19	-16.76	32.43	46.00	-13.57	peak	
5		491.6553	52.03	-13.64	38.39	46.00	-7.61	QP	
6		690.7963	42.19	-9.28	32.91	46.00	-13.09	peak	

REMARKS:

- (1) Measurement Value = Reading Level + Correct Factor.
- (2) Margin Level = Measurement Value - Limit Value.

Test Mode	IEEE 802.11ac (VHT20)	Test Date	2022/9/13
Test Frequency	5700MHz	Polarization	Horizontal
Temp	25°C	Hum.	62%

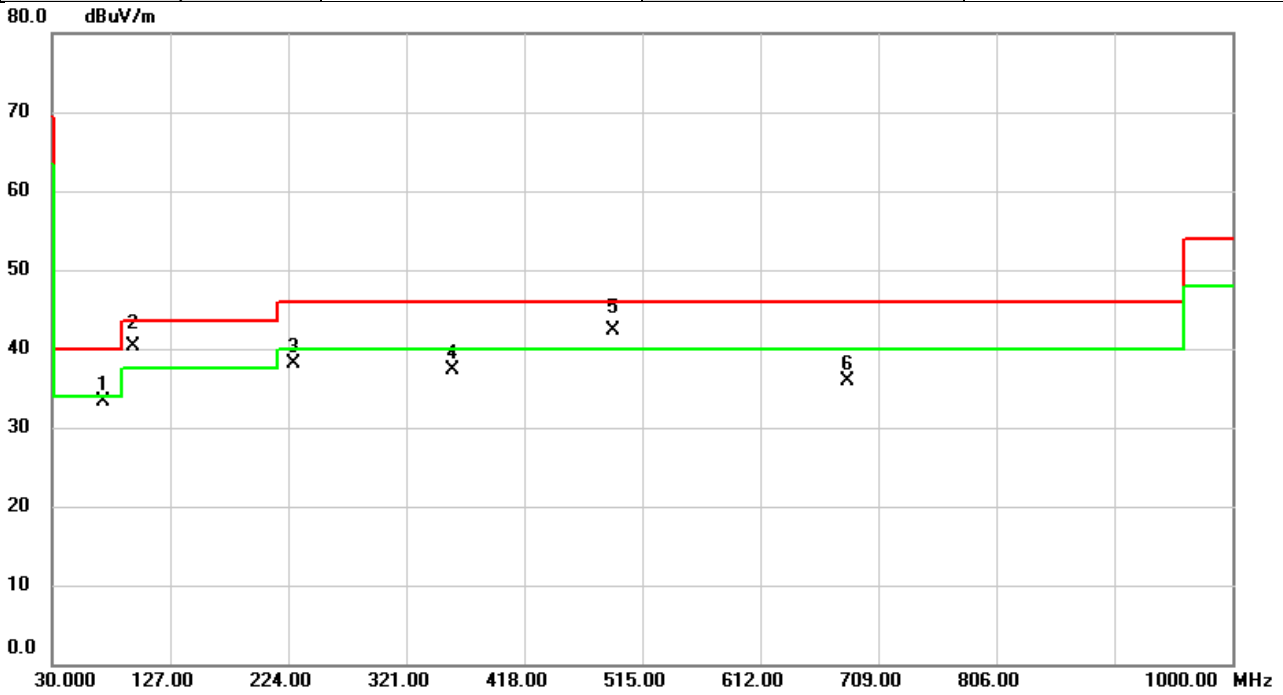

No.	Mk.	Freq.	Reading Level	Correct Factor	Measurement	Limit	Over	Detector	Comment
		MHz	dBuV	dB	dBuV/m	dBuV/m	dB		
1		72.0010	54.09	-20.76	33.33	40.00	-6.67	peak	
2	*	95.9600	62.36	-22.14	40.22	43.50	-3.28	QP	
3		229.1410	59.58	-21.49	38.09	46.00	-7.91	peak	
4		359.7353	54.00	-16.76	37.24	46.00	-8.76	peak	
5	!	491.6553	56.03	-13.64	42.39	46.00	-3.61	QP	
6		683.3597	45.20	-9.37	35.83	46.00	-10.17	peak	

REMARKS:

- (1) Measurement Value = Reading Level + Correct Factor.
- (2) Margin Level = Measurement Value - Limit Value.

APPENDIX C RADIATED EMISSIONS - ABOVE 1 GHZ

Test Mode	IEEE 802.11a	Test Date	2022/9/12
Test Frequency	5180MHz	Polarization	Vertical
Temp	25°C	Hum.	62%

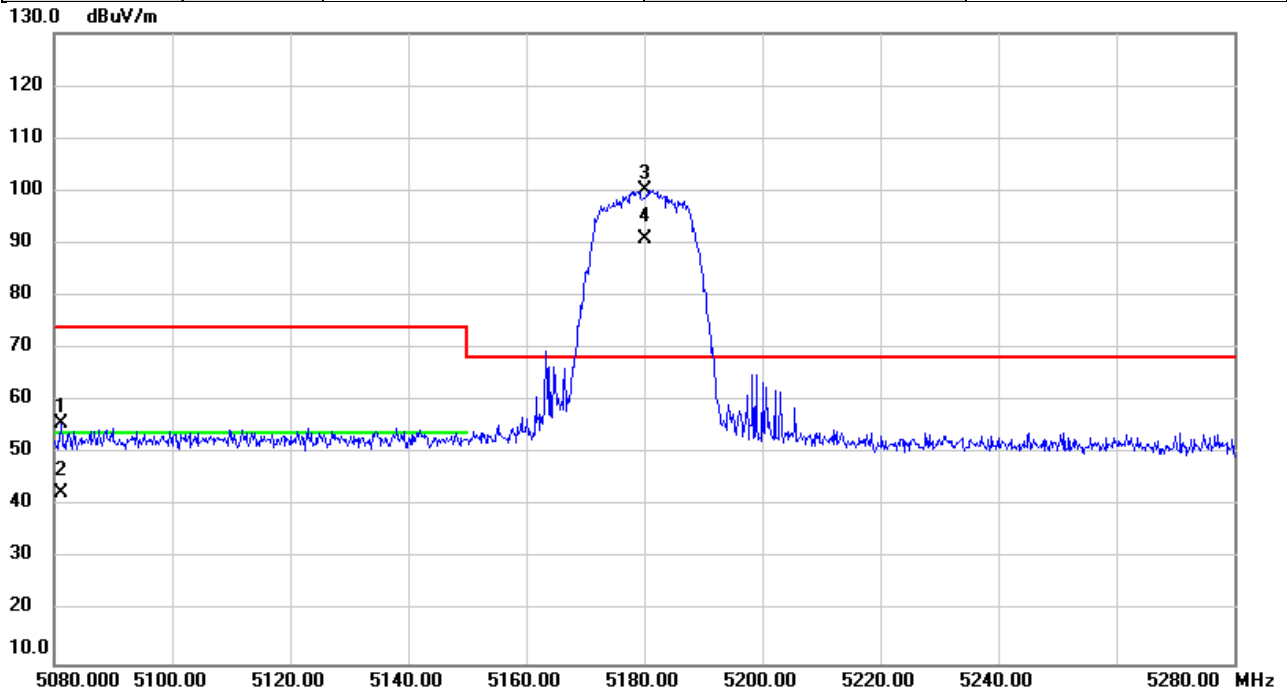

No.	Mk.	Freq.	Reading Level	Correct Factor	Measurement	Limit	Over	Detector	Comment
		MHz	dBuV	dB	dBuV/m	dBuV/m	dB		
1		5081.233	54.46	1.35	55.81	74.00	-18.19	peak	
2		5081.233	41.10	1.35	42.45	54.00	-11.55	AVG	
3	*	5180.000	98.77	1.39	100.16	68.20	31.96	peak	NoLimit
4	X	5180.000	89.41	1.39	90.80	68.20	22.60	AVG	NoLimit

REMARKS:

- (1) Measurement Value = Reading Level + Correct Factor.
- (2) Margin Level = Measurement Value - Limit Value.

Test Mode	IEEE 802.11a	Test Date	2022/9/12
Test Frequency	5240MHz	Polarization	Vertical
Temp	25°C	Hum.	62%

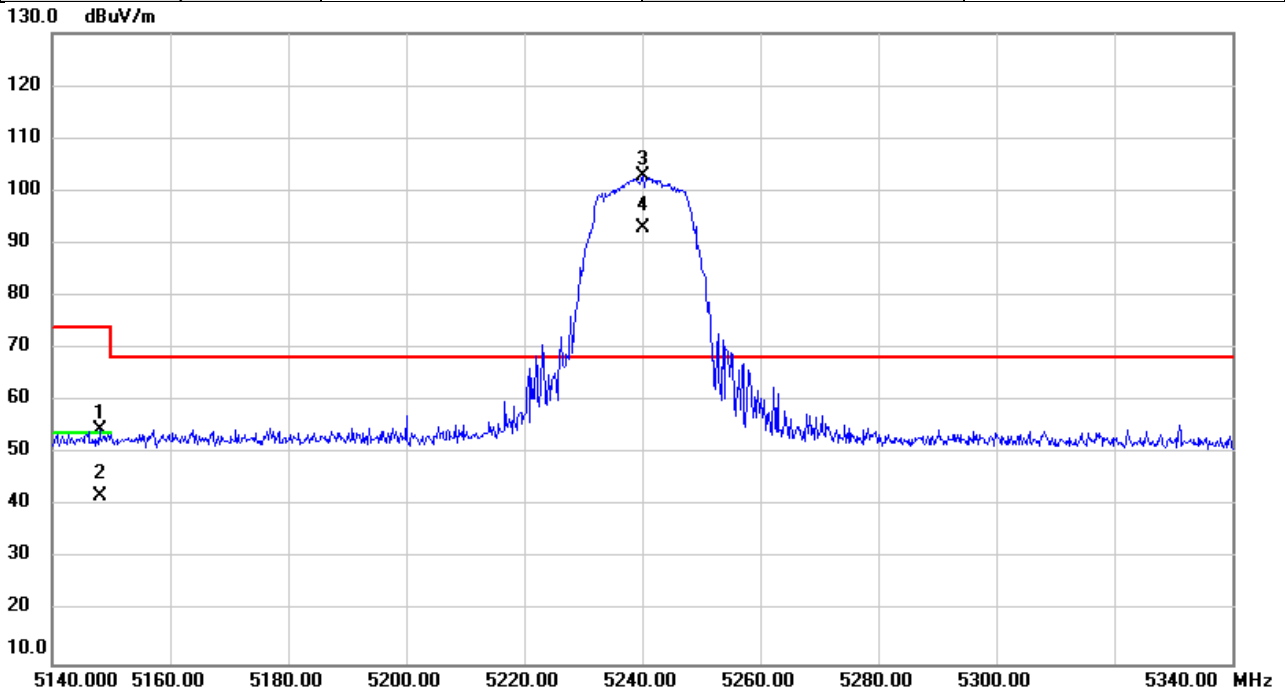

No.	Mk.	Freq.	Reading Level	Correct Factor	Measurement	Limit	Over	Detector	Comment
		MHz	dBuV	dB	dBuV/m	dBuV/m	dB		
1		5148.113	53.04	1.37	54.41	74.00	-19.59	peak	
2		5148.113	40.57	1.37	41.94	54.00	-12.06	AVG	
3	*	5240.000	101.42	1.40	102.82	68.20	34.62	peak	NoLimit
4	X	5240.000	91.43	1.40	92.83	68.20	24.63	AVG	NoLimit

REMARKS:

- (1) Measurement Value = Reading Level + Correct Factor.
- (2) Margin Level = Measurement Value - Limit Value.

Test Mode	IEEE 802.11a	Test Date	2022/9/12
Test Frequency	5260MHz	Polarization	Vertical
Temp	25°C	Hum.	62%

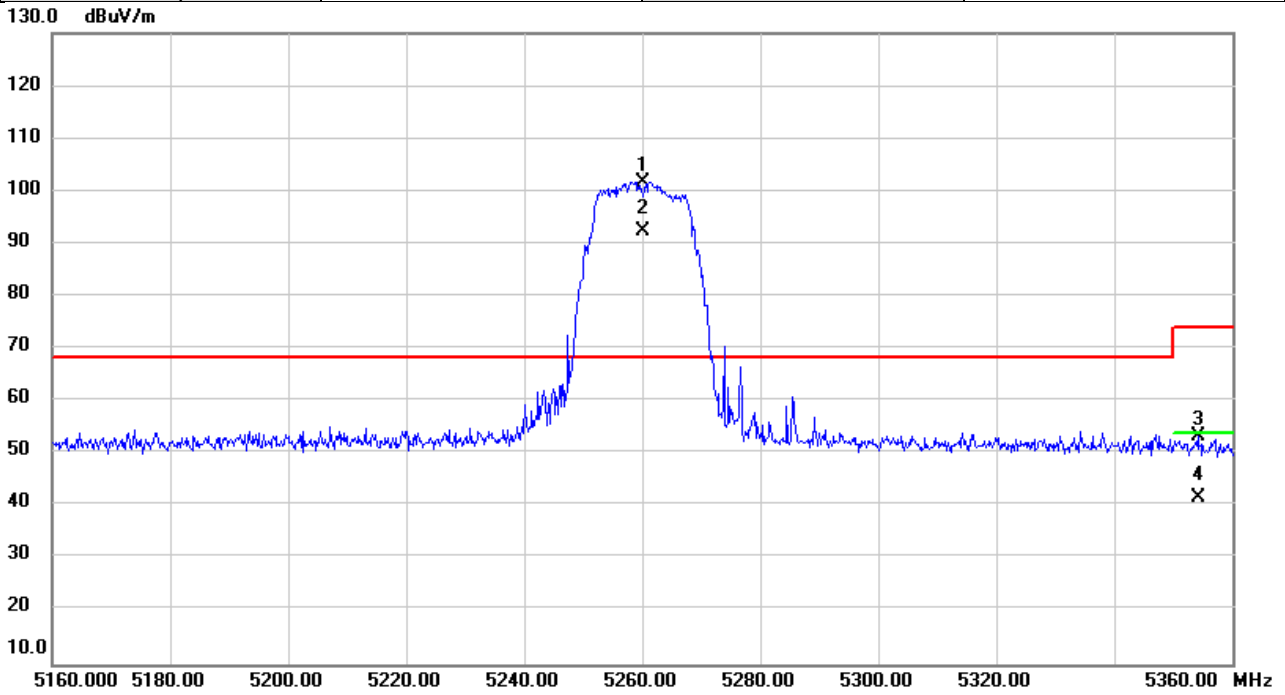

No.	Mk.	Freq.	Reading Level	Correct Factor	Measurement	Limit	Over	Detector	Comment
		MHz	dBuV	dB	dBuV/m	dBuV/m	dB		
1	*	5260.000	100.36	1.41	101.77	68.20	33.57	peak	NoLimit
2	X	5260.000	91.03	1.41	92.44	68.20	24.24	AVG	NoLimit
3		5354.140	51.87	1.44	53.31	74.00	-20.69	peak	
4		5354.140	40.29	1.44	41.73	54.00	-12.27	AVG	

REMARKS:

- (1) Measurement Value = Reading Level + Correct Factor.
- (2) Margin Level = Measurement Value - Limit Value.

Test Mode	IEEE 802.11a	Test Date	2022/9/12
Test Frequency	5320MHz	Polarization	Vertical
Temp	25°C	Hum.	62%

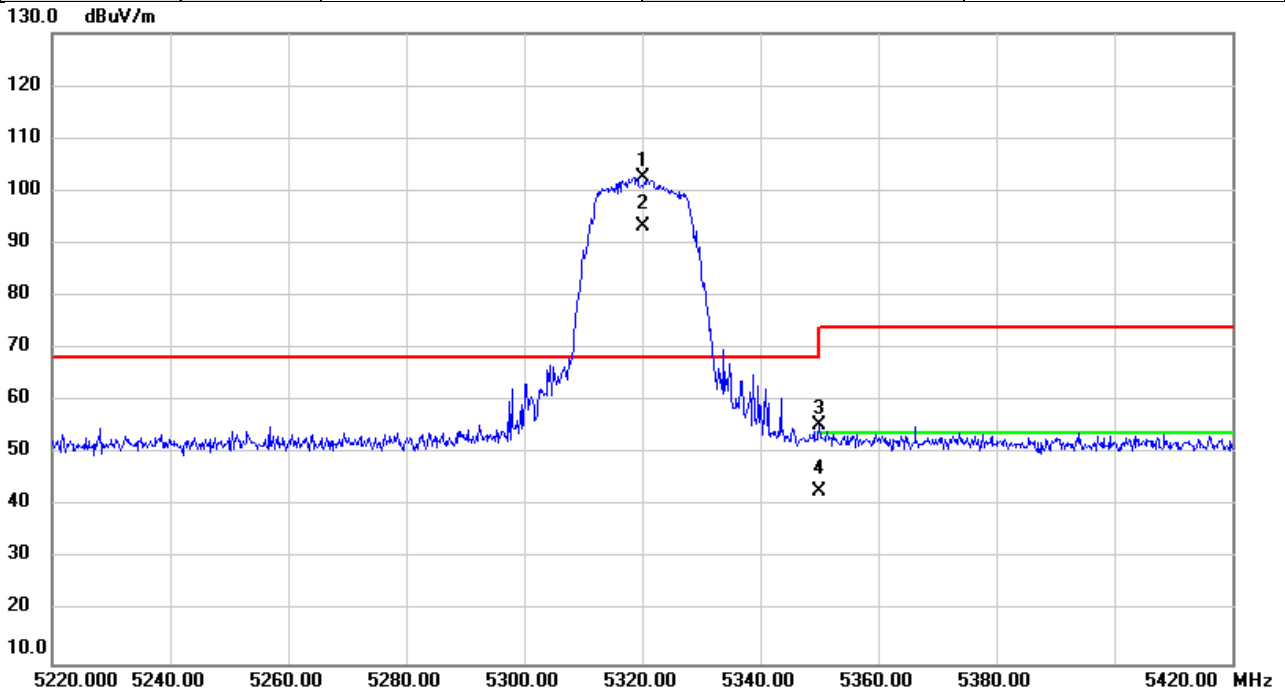

No.	Mk.	Freq.	Reading Level	Correct Factor	Measurement	Limit	Over	Detector	Comment
		MHz	dBuV	dB	dBuV/m	dBuV/m	dB		
1	*	5320.000	101.22	1.42	102.64	68.20	34.44	peak	NoLimit
2	X	5320.000	91.71	1.42	93.13	68.20	24.93	AVG	NoLimit
3		5350.060	54.08	1.43	55.51	74.00	-18.49	peak	
4		5350.060	41.50	1.43	42.93	54.00	-11.07	AVG	

REMARKS:

- (1) Measurement Value = Reading Level + Correct Factor.
- (2) Margin Level = Measurement Value - Limit Value.

Test Mode	IEEE 802.11a	Test Date	2022/9/12
Test Frequency	5500MHz	Polarization	Vertical
Temp	25°C	Hum.	62%

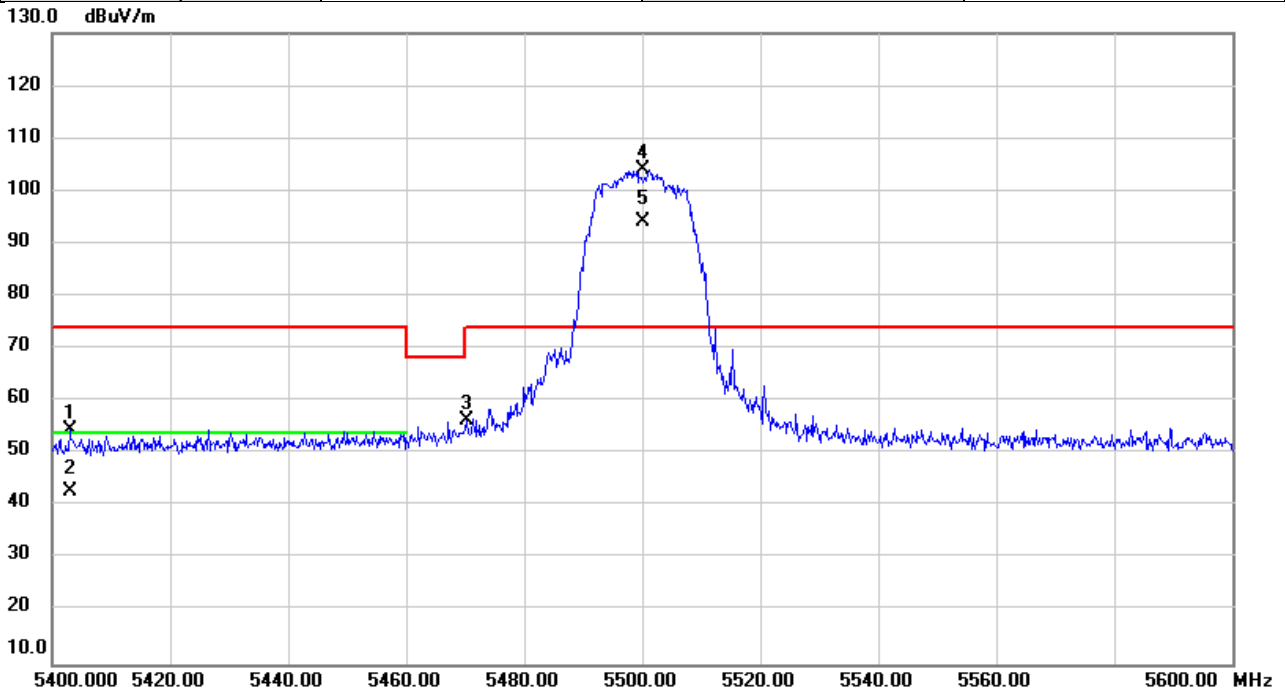

No.	Mk.	Freq.	Reading Level	Correct Factor	Measurement	Limit	Over	Detector	Comment
		MHz	dBuV	dB	dBuV/m	dBuV/m	dB		
1		5403.180	53.09	1.46	54.55	74.00	-19.45	peak	
2		5403.180	41.49	1.46	42.95	54.00	-11.05	AVG	
3		5470.193	54.94	1.48	56.42	74.00	-17.58	peak	
4	*	5500.000	102.46	1.49	103.95	74.00	29.95	peak	NoLimit
5	X	5500.000	92.74	1.49	94.23	74.00	20.23	AVG	NoLimit

REMARKS:

- (1) Measurement Value = Reading Level + Correct Factor.
- (2) Margin Level = Measurement Value - Limit Value.

Test Mode	IEEE 802.11a	Test Date	2022/9/12
Test Frequency	5700MHz	Polarization	Vertical
Temp	25°C	Hum.	62%

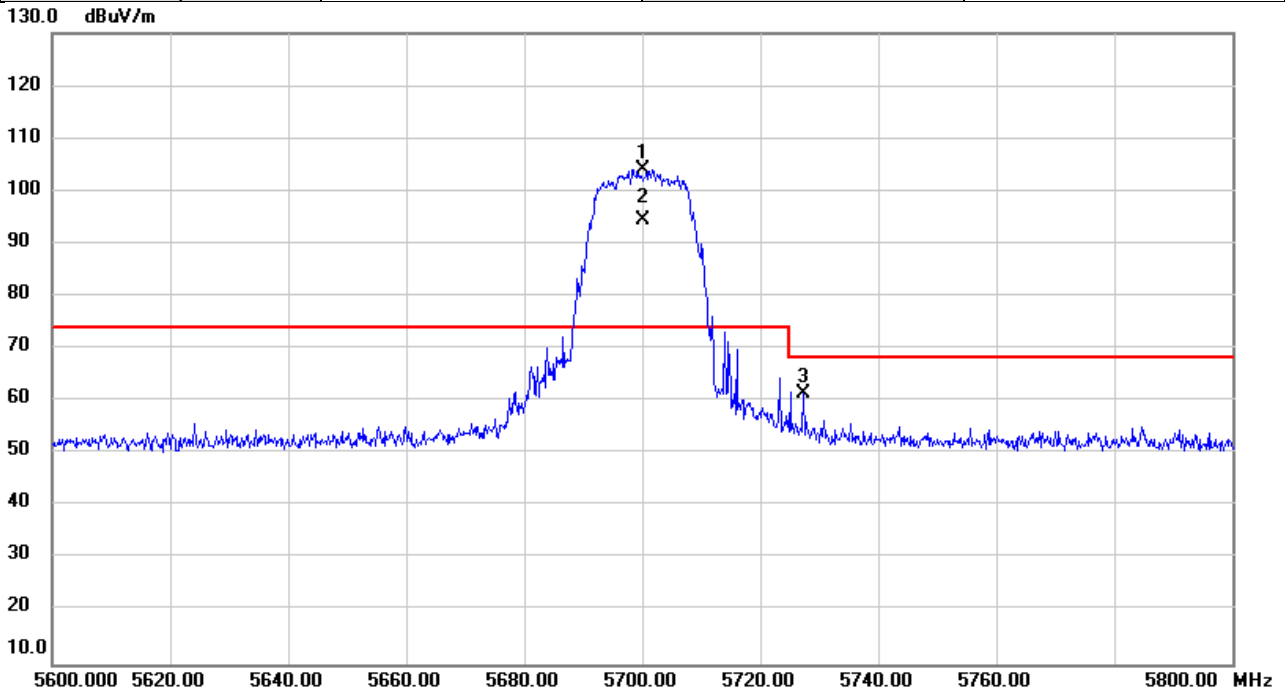

No.	Mk.	Freq.	Reading Level	Correct Factor	Measurement	Limit	Over	Detector	Comment
		MHz	dBuV	dB	dBuV/m	dBuV/m	dB		
1	*	5700.000	102.20	1.89	104.09	74.00	30.09	peak	NoLimit
2	X	5700.000	92.69	1.89	94.58	74.00	20.58	AVG	NoLimit
3		5727.307	59.36	1.95	61.31	68.20	-6.89	peak	

REMARKS:

- (1) Measurement Value = Reading Level + Correct Factor.
- (2) Margin Level = Measurement Value - Limit Value.

Test Mode	IEEE 802.11ac (VHT20)	Test Date	2022/9/13
Test Frequency	5180MHz	Polarization	Vertical
Temp	25°C	Hum.	62%

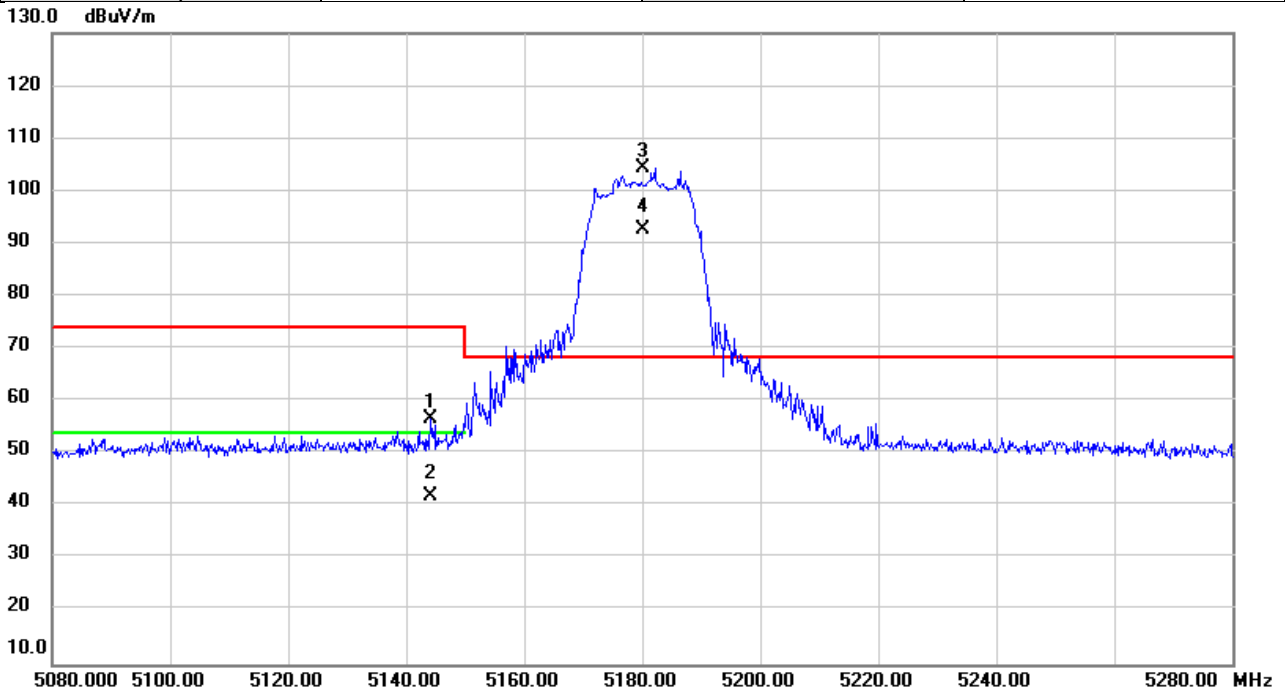

No.	Mk.	Freq.	Reading Level	Correct Factor	Measurement	Limit	Over	Detector	Comment
		MHz	dBuV	dB	dBuV/m	dBuV/m	dB		
1		5144.140	64.93	-8.33	56.60	74.00	-17.40	peak	
2		5144.140	50.19	-8.33	41.86	54.00	-12.14	AVG	
3	*	5180.000	112.68	-8.32	104.36	68.20	36.16	peak	NoLimit
4	X	5180.000	101.01	-8.32	92.69	68.20	24.49	AVG	NoLimit

REMARKS:

- (1) Measurement Value = Reading Level + Correct Factor.
- (2) Margin Level = Measurement Value - Limit Value.

Test Mode	IEEE 802.11ac (VHT20)	Test Date	2022/9/13
Test Frequency	5240MHz	Polarization	Vertical
Temp	25°C	Hum.	62%

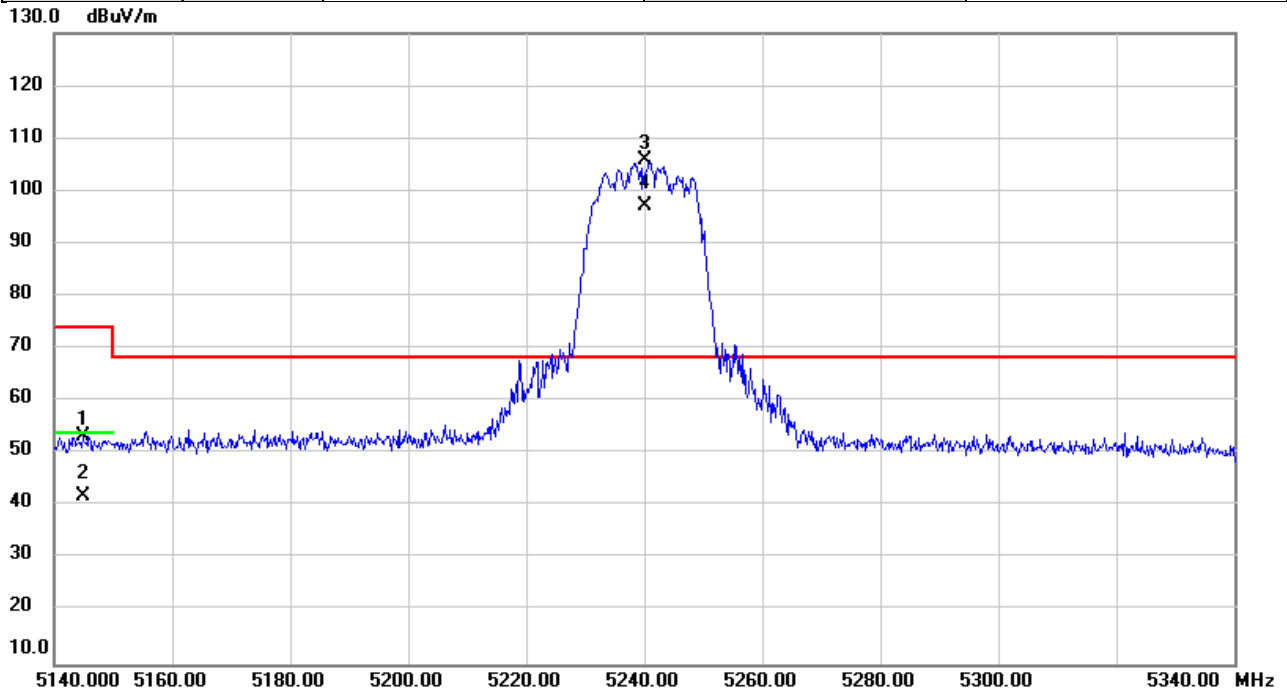

No.	Mk.	Freq.	Reading Level	Correct Factor	Measurement	Limit	Over	Detector	Comment
		MHz	dBuV	dB	dBuV/m	dBuV/m	dB		
1		5144.973	61.75	-8.33	53.42	74.00	-20.58	peak	
2		5144.973	50.23	-8.33	41.90	54.00	-12.10	AVG	
3	*	5240.000	114.08	-8.33	105.75	68.20	37.55	peak	NoLimit
4	X	5240.000	105.62	-8.33	97.29	68.20	29.09	AVG	NoLimit

REMARKS:

- (1) Measurement Value = Reading Level + Correct Factor.
- (2) Margin Level = Measurement Value - Limit Value.

Test Mode	IEEE 802.11ac (VHT20)	Test Date	2022/9/13
Test Frequency	5260MHz	Polarization	Vertical
Temp	25°C	Hum.	62%

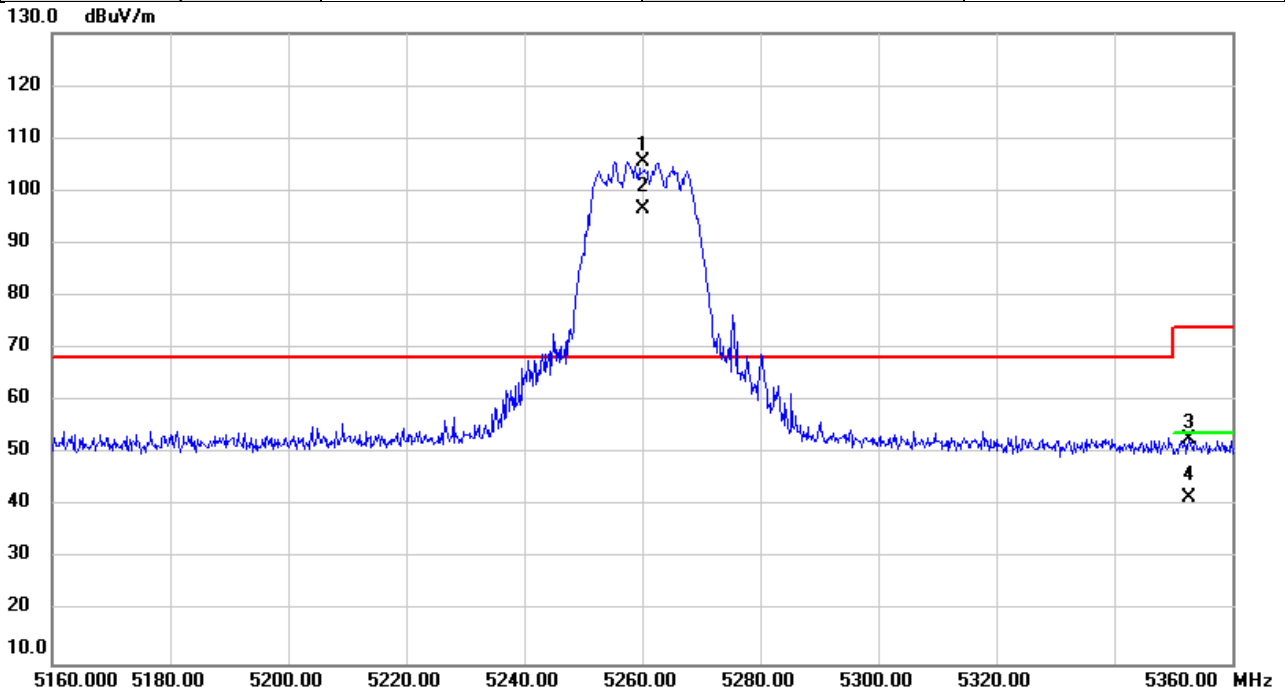

No.	Mk.	Freq.	Reading Level	Correct Factor	Measurement	Limit	Over	Detector	Comment
		MHz	dBuV	dB	dBuV/m	dBuV/m	dB		
1	*	5260.000	114.01	-8.32	105.69	68.20	37.49	peak	NoLimit
2	X	5260.000	104.77	-8.32	96.45	68.20	28.25	AVG	NoLimit
3		5352.640	61.10	-8.32	52.78	74.00	-21.22	peak	
4		5352.640	49.83	-8.32	41.51	54.00	-12.49	AVG	

REMARKS:

- (1) Measurement Value = Reading Level + Correct Factor.
- (2) Margin Level = Measurement Value - Limit Value.

Test Mode	IEEE 802.11ac (VHT20)	Test Date	2022/9/13
Test Frequency	5320MHz	Polarization	Vertical
Temp	25°C	Hum.	62%

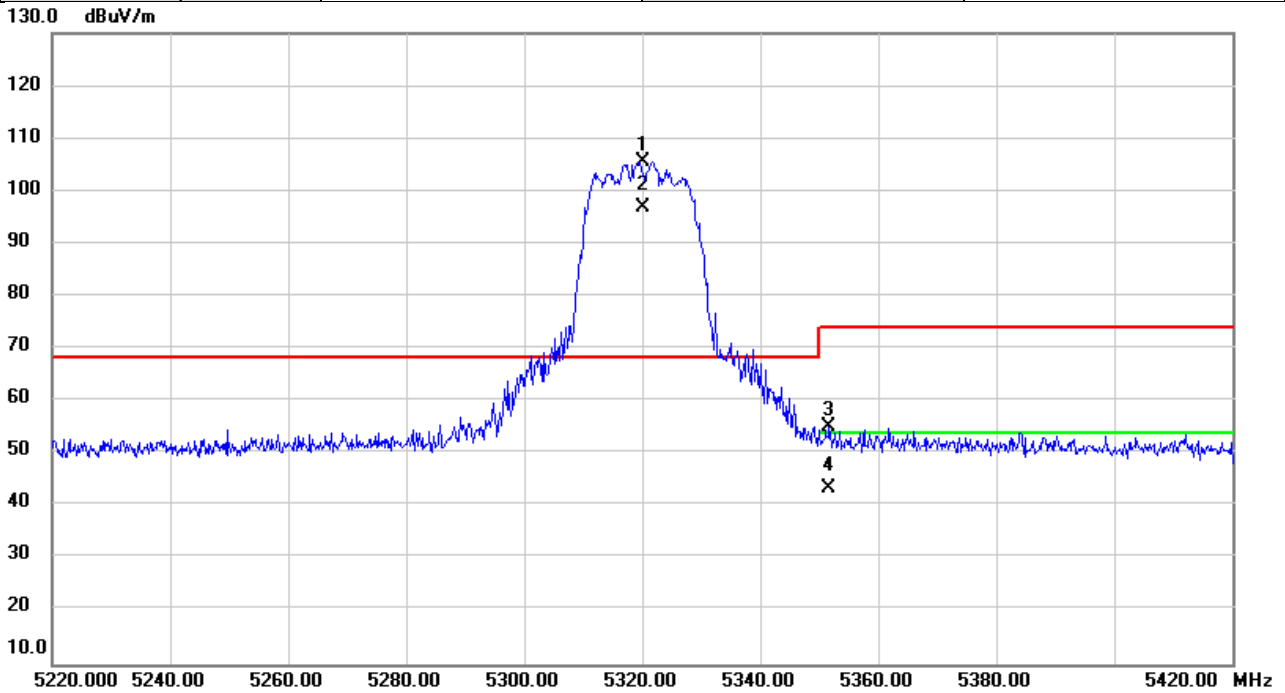

No.	Mk.	Freq.	Reading Level	Correct Factor	Measurement	Limit	Over	Detector	Comment
		MHz	dBuV	dB	dBuV/m	dBuV/m	dB		
1	*	5320.000	113.85	-8.33	105.52	68.20	37.32	peak	NoLimit
2	X	5320.000	105.26	-8.33	96.93	68.20	28.73	AVG	NoLimit
3		5351.727	63.56	-8.32	55.24	74.00	-18.76	peak	
4		5351.727	51.73	-8.32	43.41	54.00	-10.59	AVG	

REMARKS:

- (1) Measurement Value = Reading Level + Correct Factor.
- (2) Margin Level = Measurement Value - Limit Value.

Test Mode	IEEE 802.11ac (VHT20)	Test Date	2022/9/13
Test Frequency	5500MHz	Polarization	Vertical
Temp	25°C	Hum.	62%

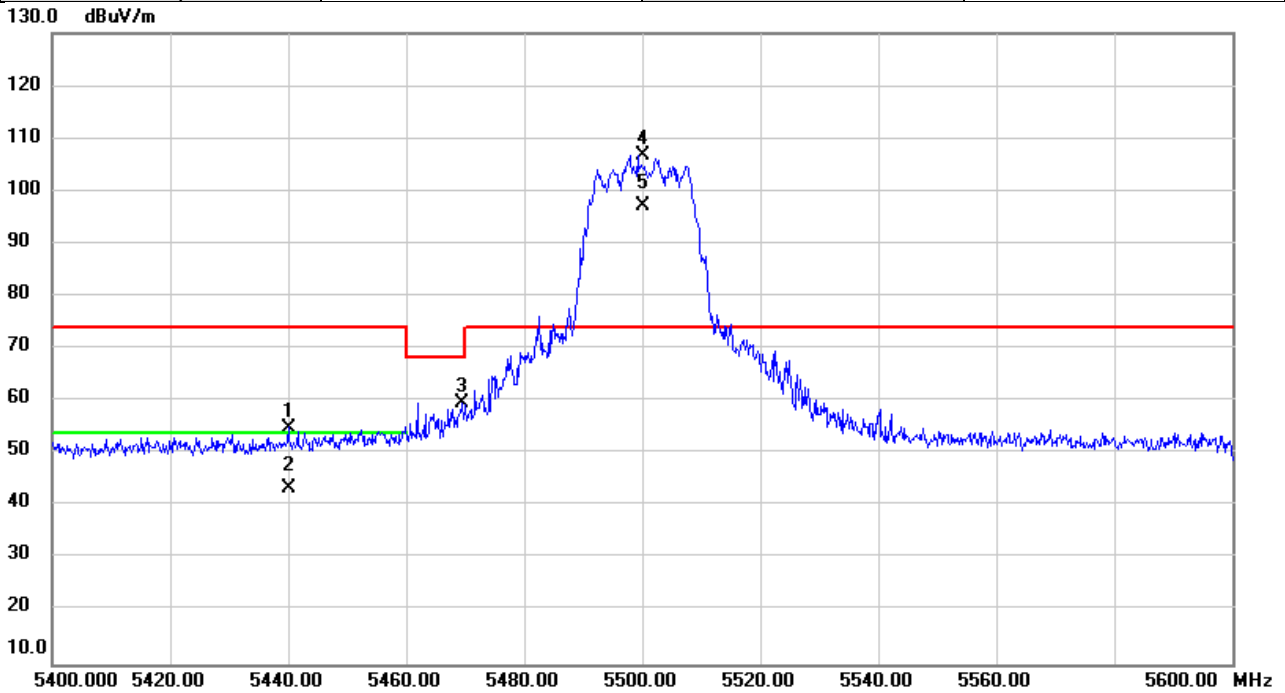

No.	Mk.	Freq.	Reading Level	Correct Factor	Measurement	Limit	Over	Detector	Comment
		MHz	dBuV	dB	dBuV/m	dBuV/m	dB		
1		5440.167	63.33	-8.33	55.00	74.00	-19.00	peak	
2		5440.167	51.68	-8.33	43.35	54.00	-10.65	AVG	
3		5469.407	68.11	-8.33	59.78	68.20	-8.42	peak	
4	*	5500.000	114.96	-8.33	106.63	74.00	32.63	peak	NoLimit
5	X	5500.000	105.34	-8.33	97.01	74.00	23.01	AVG	NoLimit

REMARKS:

- (1) Measurement Value = Reading Level + Correct Factor.
- (2) Margin Level = Measurement Value - Limit Value.

Test Mode	IEEE 802.11ac (VHT20)	Test Date	2022/9/13
Test Frequency	5700MHz	Polarization	Vertical
Temp	25°C	Hum.	62%

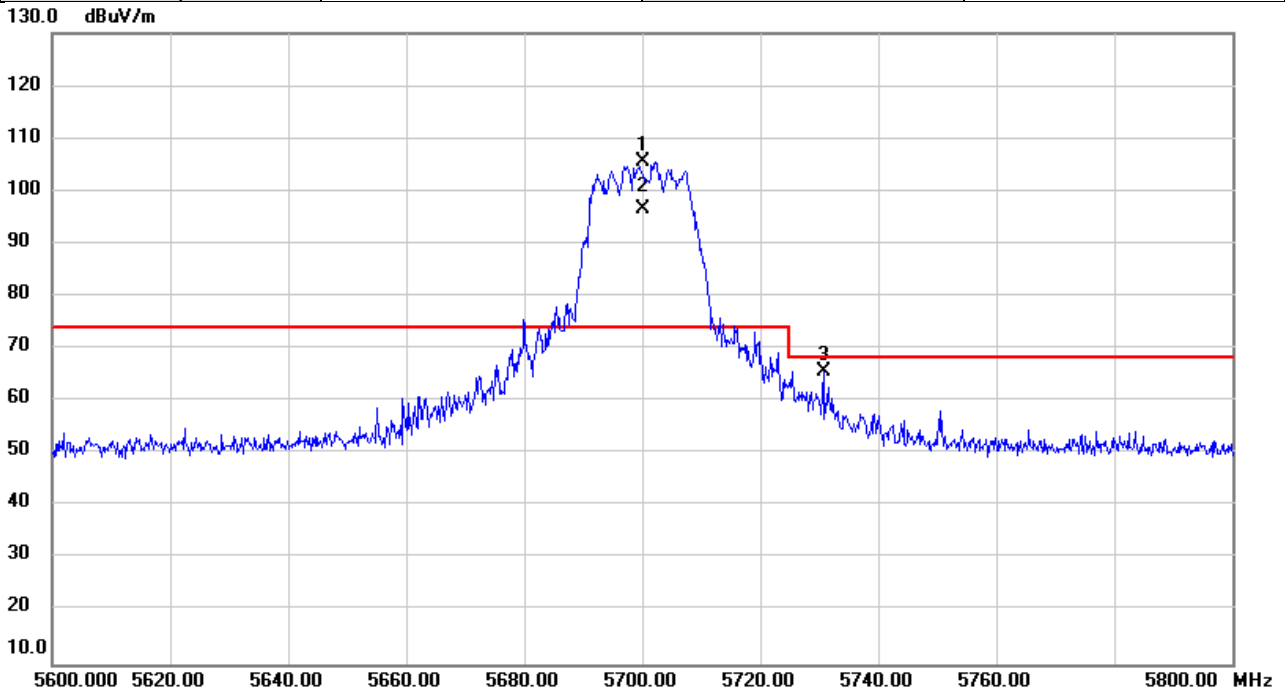

No.	Mk.	Freq.	Reading Level	Correct Factor	Measurement	Limit	Over	Detector	Comment
		MHz	dBuV	dB	dBuV/m	dBuV/m	dB		
1	*	5700.000	113.65	-7.96	105.69	74.00	31.69	peak	NoLimit
2	X	5700.000	104.62	-7.96	96.66	74.00	22.66	AVG	NoLimit
3		5730.673	73.57	-7.90	65.67	68.20	-2.53	peak	

REMARKS:

- (1) Measurement Value = Reading Level + Correct Factor.
- (2) Margin Level = Measurement Value - Limit Value.

Test Mode	IEEE 802.11ac (VHT40)	Test Date	2022/9/13
Test Frequency	5190MHz	Polarization	Vertical
Temp	25°C	Hum.	62%

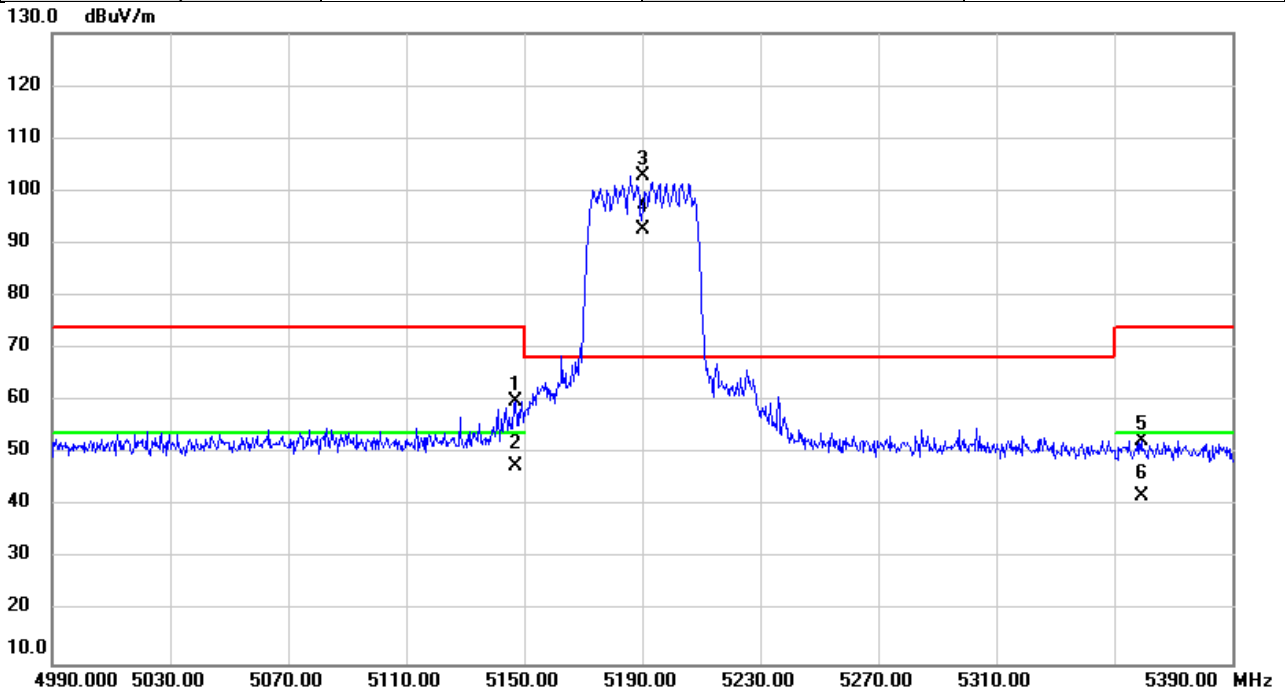

No.	Mk.	Freq.	Reading Level	Correct Factor	Measurement	Limit	Over	Detector	Comment
		MHz	dBuV	dB	dBuV/m	dBuV/m	dB		
1		5146.813	68.21	-8.33	59.88	74.00	-14.12	peak	
2		5146.813	55.92	-8.33	47.59	54.00	-6.41	AVG	
3	*	5190.000	111.06	-8.33	102.73	68.20	34.53	peak	NoLimit
4	X	5190.000	101.06	-8.33	92.73	68.20	24.53	AVG	NoLimit
5		5359.133	60.82	-8.33	52.49	74.00	-21.51	peak	
6		5359.133	50.18	-8.33	41.85	54.00	-12.15	AVG	

REMARKS:

- (1) Measurement Value = Reading Level + Correct Factor.
- (2) Margin Level = Measurement Value - Limit Value.

Test Mode	IEEE 802.11ac (VHT40)	Test Date	2022/9/13
Test Frequency	5230MHz	Polarization	Vertical
Temp	25°C	Hum.	62%

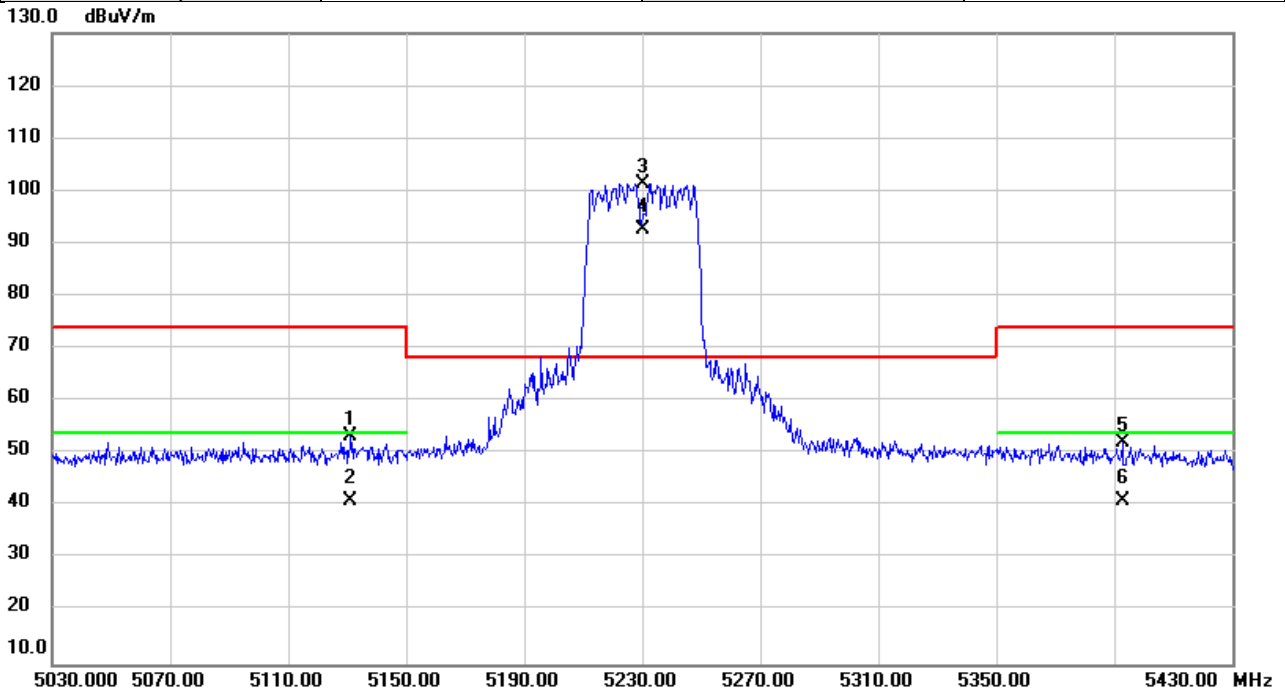

No.	Mk.	Freq.	Reading Level	Correct Factor	Measurement	Limit	Over	Detector	Comment
		MHz	dBuV	dB	dBuV/m	dBuV/m	dB		
1		5131.253	61.67	-8.33	53.34	74.00	-20.66	peak	
2		5131.253	49.25	-8.33	40.92	54.00	-13.08	AVG	
3	*	5230.000	109.75	-8.32	101.43	68.20	33.23	peak	NoLimit
4	X	5230.000	101.03	-8.32	92.71	68.20	24.51	AVG	NoLimit
5		5393.000	60.43	-8.33	52.10	74.00	-21.90	peak	
6		5393.000	49.52	-8.33	41.19	54.00	-12.81	AVG	

REMARKS:

- (1) Measurement Value = Reading Level + Correct Factor.
- (2) Margin Level = Measurement Value - Limit Value.

Test Mode	IEEE 802.11ac (VHT40)	Test Date	2022/9/13
Test Frequency	5270MHz	Polarization	Vertical
Temp	25°C	Hum.	62%

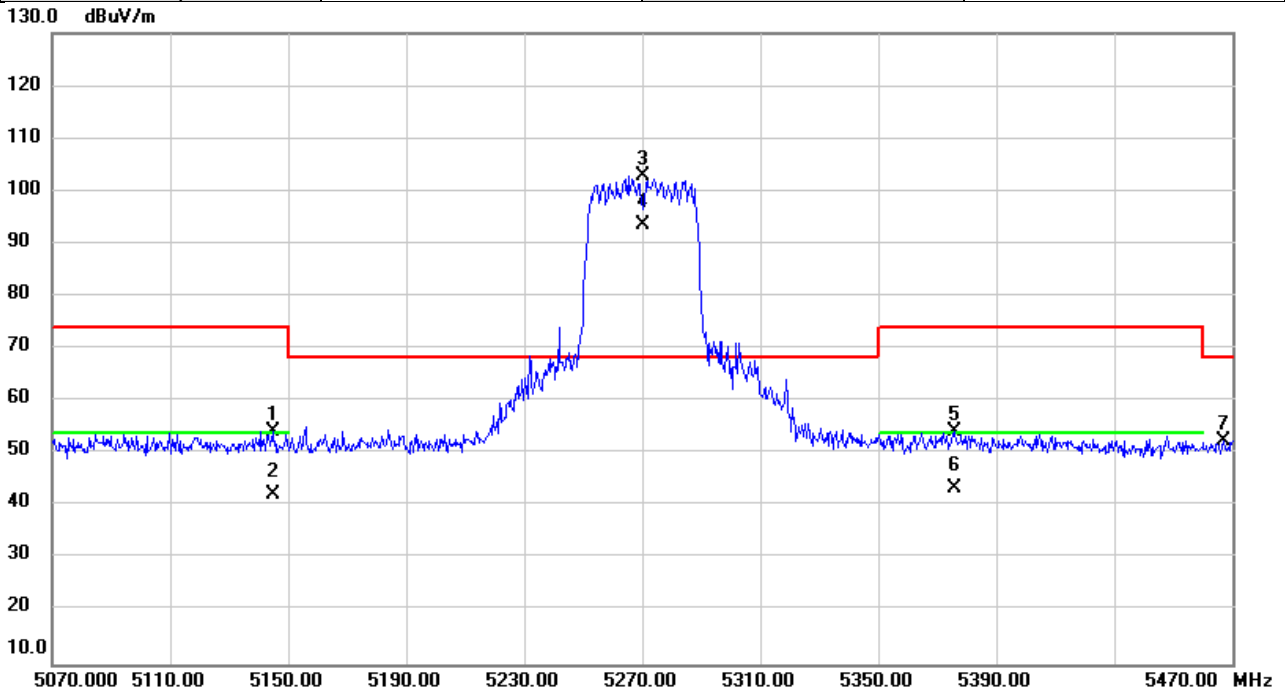

No.	Mk.	Freq.	Reading Level	Correct Factor	Measurement	Limit	Over	Detector	Comment
		MHz	dBuV	dB	dBuV/m	dBuV/m	dB		
1		5144.747	62.51	-8.33	54.18	74.00	-19.82	peak	
2		5144.747	50.65	-8.33	42.32	54.00	-11.68	AVG	
3	*	5270.000	111.07	-8.33	102.74	68.20	34.54	peak	NoLimit
4	X	5270.000	101.97	-8.33	93.64	68.20	25.44	AVG	NoLimit
5		5375.640	62.63	-8.33	54.30	74.00	-19.70	peak	
6		5375.640	51.77	-8.33	43.44	54.00	-10.56	AVG	
7		5467.147	60.72	-8.33	52.39	68.20	-15.81	peak	

REMARKS:

- (1) Measurement Value = Reading Level + Correct Factor.
- (2) Margin Level = Measurement Value - Limit Value.

Test Mode	IEEE 802.11ac (VHT40)	Test Date	2022/9/13
Test Frequency	5310MHz	Polarization	Vertical
Temp	25°C	Hum.	62%

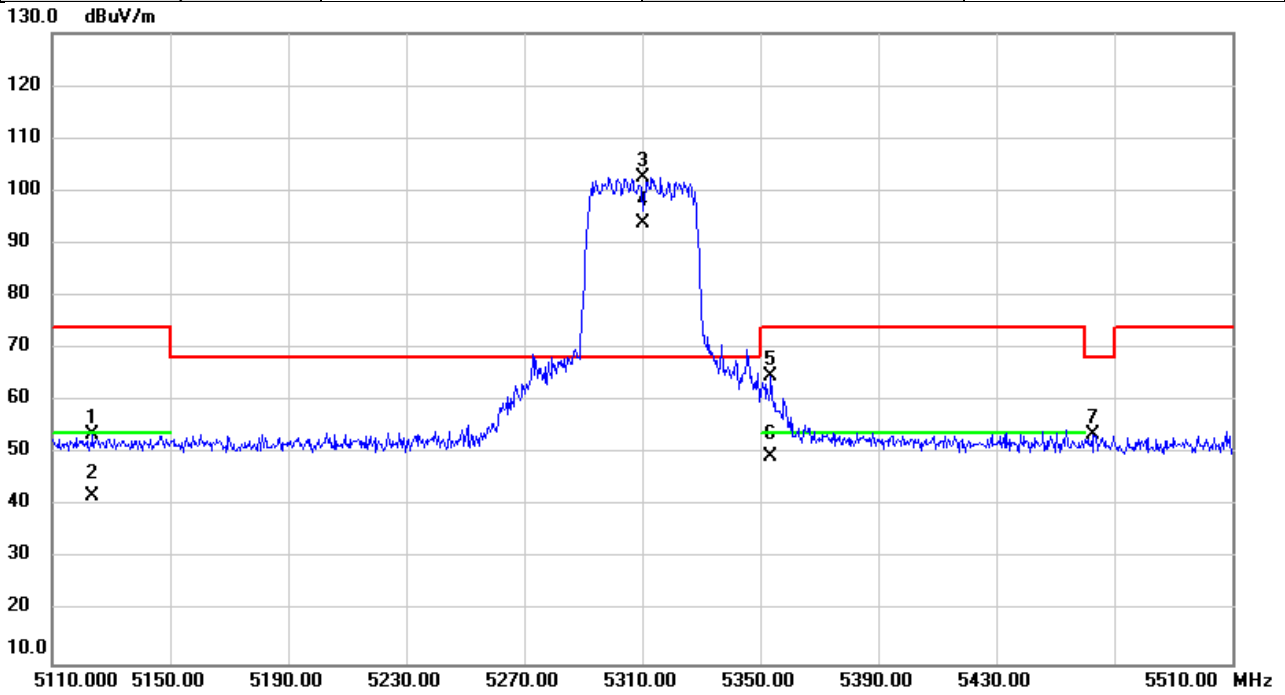

No.	Mk.	Freq.	Reading Level	Correct Factor	Measurement	Limit	Over	Detector	Comment
		MHz	dBuV	dB	dBuV/m	dBuV/m	dB		
1		5123.733	62.10	-8.32	53.78	74.00	-20.22	peak	
2		5123.733	50.36	-8.32	42.04	54.00	-11.96	AVG	
3	*	5310.000	110.92	-8.32	102.60	68.20	34.40	peak	NoLimit
4	X	5310.000	102.03	-8.32	93.71	68.20	25.51	AVG	NoLimit
5		5353.640	72.99	-8.32	64.67	74.00	-9.33	peak	
6		5353.640	57.92	-8.32	49.60	54.00	-4.40	AVG	
7		5463.000	62.10	-8.33	53.77	68.20	-14.43	peak	

REMARKS:

- (1) Measurement Value = Reading Level + Correct Factor.
- (2) Margin Level = Measurement Value - Limit Value.

Test Mode	IEEE 802.11ac (VHT40)	Test Date	2022/9/13
Test Frequency	5510MHz	Polarization	Vertical
Temp	25°C	Hum.	62%

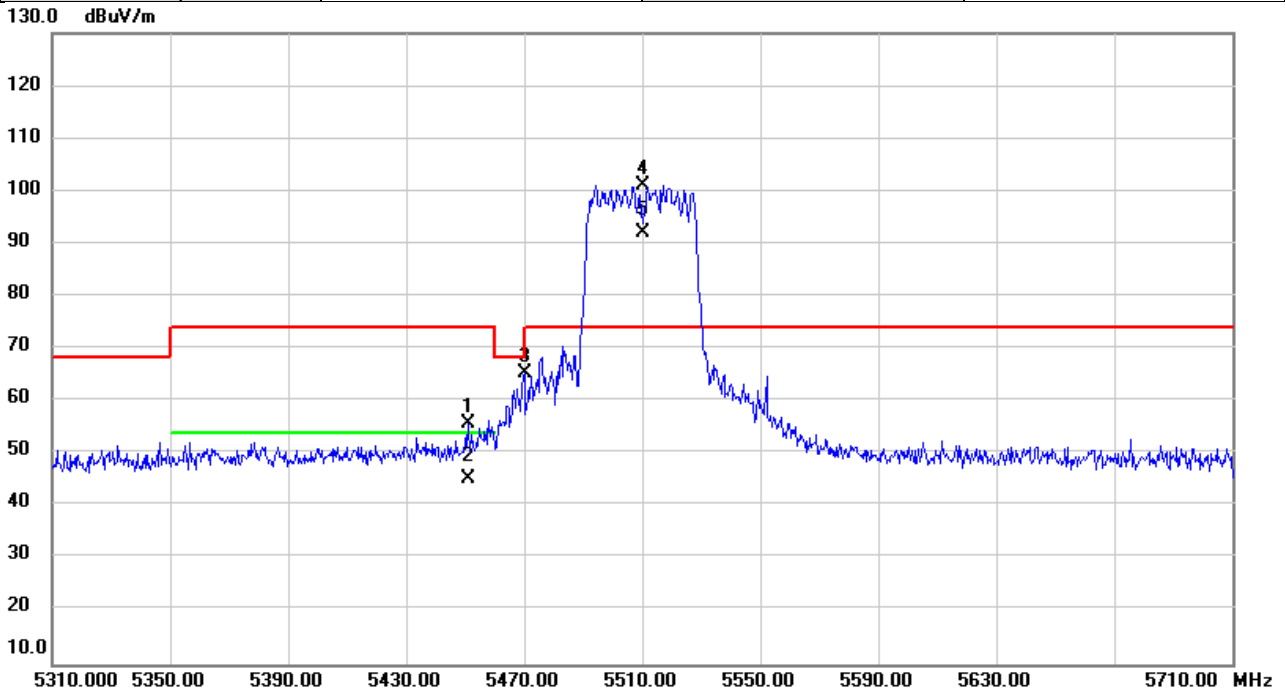

No.	Mk.	Freq.	Reading Level	Correct Factor	Measurement	Limit	Over	Detector	Comment
		MHz	dBuV	dB	dBuV/m	dBuV/m	dB		
1		5451.160	64.10	-8.33	55.77	74.00	-18.23	peak	
2		5451.160	53.44	-8.33	45.11	54.00	-8.89	AVG	
3		5470.000	73.69	-8.33	65.36	68.20	-2.84	peak	
4	*	5510.000	109.26	-8.31	100.95	74.00	26.95	peak	NoLimit
5	X	5510.000	100.22	-8.31	91.91	74.00	17.91	AVG	NoLimit

REMARKS:

- (1) Measurement Value = Reading Level + Correct Factor.
- (2) Margin Level = Measurement Value - Limit Value.

Test Mode	IEEE 802.11ac (VHT40)	Test Date	2022/9/13
Test Frequency	5670MHz	Polarization	Vertical
Temp	25°C	Hum.	62%

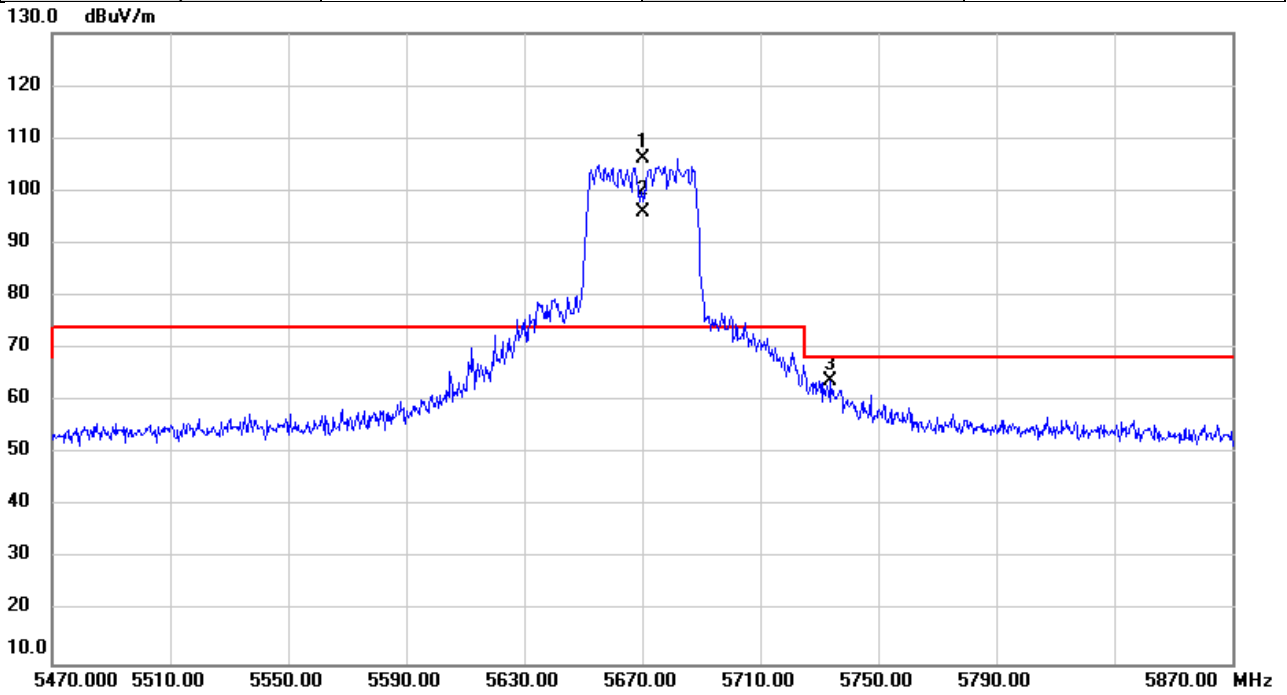

No.	Mk.	Freq.	Reading Level	Correct Factor	Measurement	Limit	Over	Detector	Comment
		MHz	dBuV	dB	dBuV/m	dBuV/m	dB		
1	*	5670.000	99.85	6.42	106.27	74.00	32.27	peak	NoLimit
2	X	5670.000	89.63	6.42	96.05	74.00	22.05	AVG	NoLimit
3		5733.747	57.53	6.46	63.99	68.20	-4.21	peak	

REMARKS:

- (1) Measurement Value = Reading Level + Correct Factor.
- (2) Margin Level = Measurement Value - Limit Value.

Test Mode	IEEE 802.11ac (VHT80)	Test Date	2022/9/13
Test Frequency	5210MHz	Polarization	Vertical
Temp	25°C	Hum.	62%

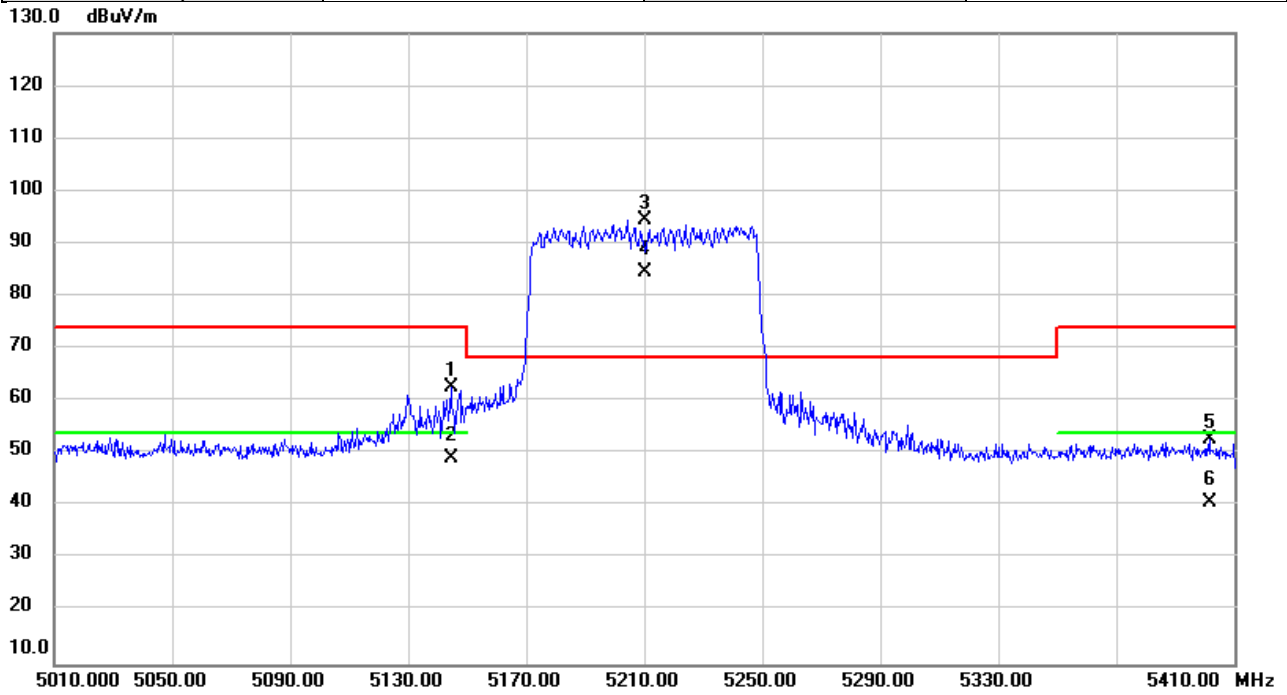

No.	Mk.	Freq.	Reading Level	Correct Factor	Measurement	Limit	Over	Detector	Comment
		MHz	dBuV	dB	dBuV/m	dBuV/m	dB		
1		5144.533	70.91	-8.33	62.58	74.00	-11.42	peak	
2		5144.533	57.46	-8.33	49.13	54.00	-4.87	AVG	
3	*	5210.000	102.71	-8.33	94.38	68.20	26.18	peak	NoLimit
4	X	5210.000	92.74	-8.33	84.41	68.20	16.21	AVG	NoLimit
5		5401.493	61.19	-8.32	52.87	74.00	-21.13	peak	
6		5401.493	49.04	-8.32	40.72	54.00	-13.28	AVG	

REMARKS:

- (1) Measurement Value = Reading Level + Correct Factor.
- (2) Margin Level = Measurement Value - Limit Value.

Test Mode	IEEE 802.11ac (VHT80)	Test Date	2022/9/14
Test Frequency	5290MHz	Polarization	Vertical
Temp	25°C	Hum.	62%

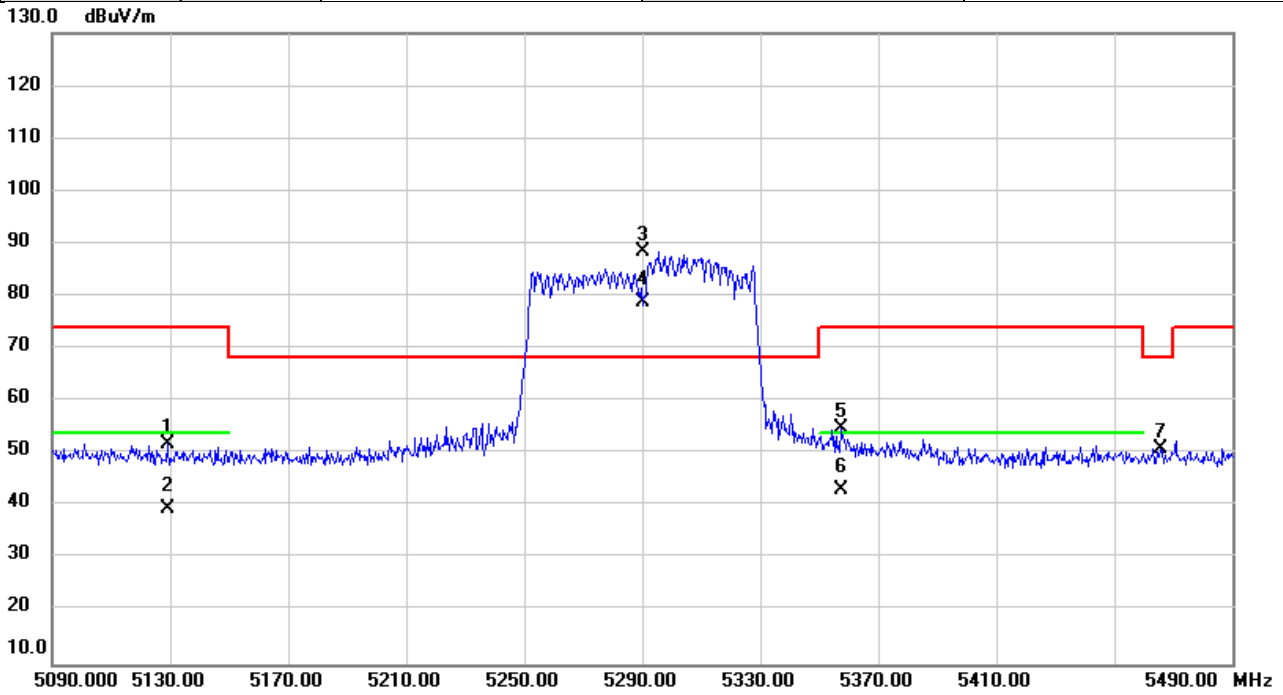

No.	Mk.	Freq.	Reading Level	Correct Factor	Measurement	Limit	Over	Detector	Comment
		MHz	dBuV	dB	dBuV/m	dBuV/m	dB		
1		5129.027	60.25	-8.33	51.92	74.00	-22.08	peak	
2		5129.027	47.96	-8.33	39.63	54.00	-14.37	AVG	
3	*	5290.000	96.66	-8.32	88.34	68.20	20.14	peak	NoLimit
4	X	5290.000	87.14	-8.32	78.82	68.20	10.62	AVG	NoLimit
5		5357.267	63.13	-8.33	54.80	74.00	-19.20	peak	
6		5357.267	51.37	-8.33	43.04	54.00	-10.96	AVG	
7		5465.800	59.33	-8.33	51.00	68.20	-17.20	peak	

REMARKS:

- (1) Measurement Value = Reading Level + Correct Factor.
- (2) Margin Level = Measurement Value - Limit Value.

Test Mode	IEEE 802.11ac (VHT80)	Test Date	2022/9/14
Test Frequency	5530MHz	Polarization	Vertical
Temp	25°C	Hum.	62%

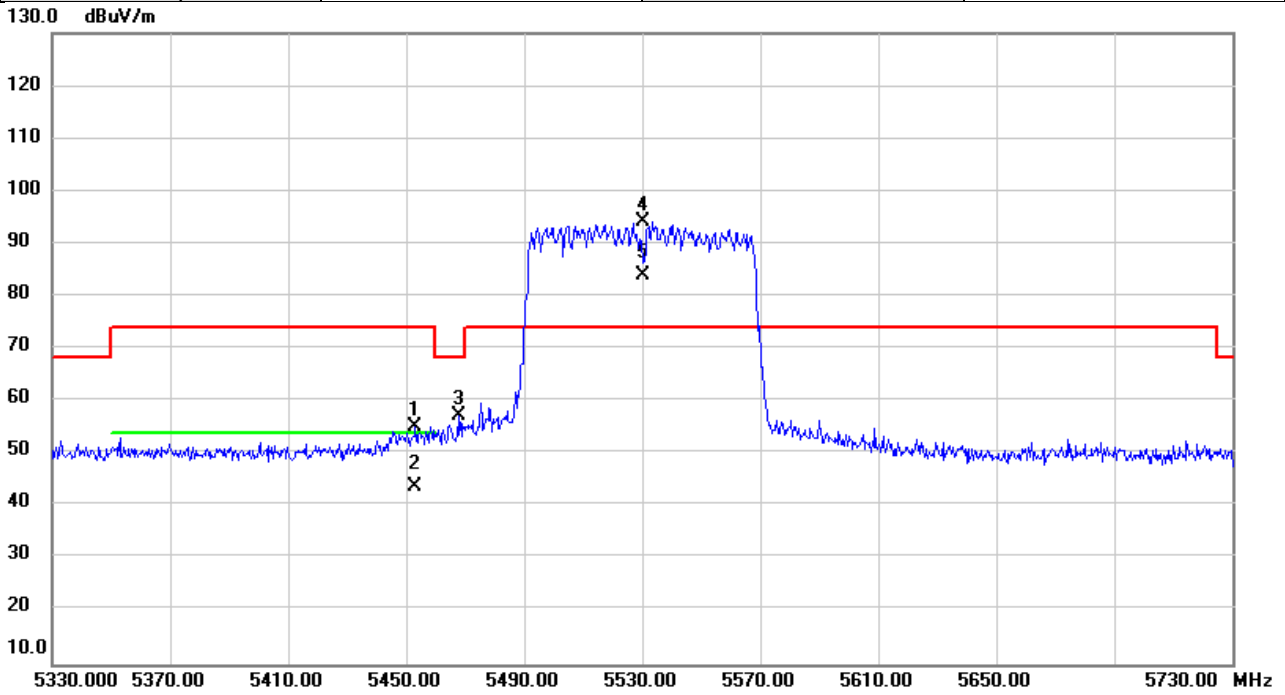

No.	Mk.	Freq.	Reading Level	Correct Factor	Measurement	Limit	Over	Detector	Comment
		MHz	dBuV	dB	dBuV/m	dBuV/m	dB		
1		5452.893	63.53	-8.33	55.20	74.00	-18.80	peak	
2		5452.893	52.03	-8.33	43.70	54.00	-10.30	AVG	
3		5468.067	65.66	-8.33	57.33	68.20	-10.87	peak	
4	*	5530.000	102.34	-8.27	94.07	74.00	20.07	peak	NoLimit
5	X	5530.000	92.19	-8.27	83.92	74.00	9.92	AVG	NoLimit

REMARKS:

- (1) Measurement Value = Reading Level + Correct Factor.
- (2) Margin Level = Measurement Value - Limit Value.

Test Mode	IEEE 802.11a	Test Date	2022/9/14
Test Frequency	5180MHz	Polarization	Vertical
Temp	25°C	Hum.	62%

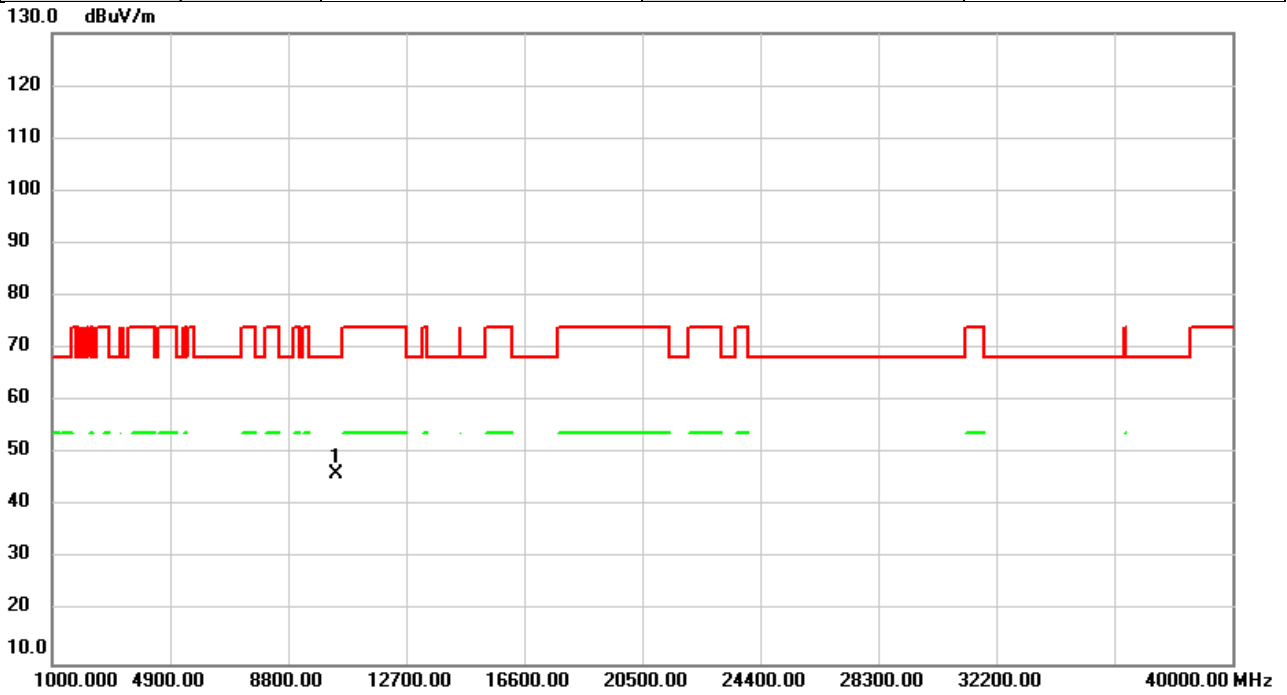

No.	Mk.	Freq. MHz	Reading Level dBuV	Correct Factor dB	Measure- ment dBuV/m	Limit dBuV/m	Over dB	Detector	Comment
1	*	10360.00	45.20	1.02	46.22	68.20	-21.98	peak	

REMARKS:

- (1) Measurement Value = Reading Level + Correct Factor.
- (2) Margin Level = Measurement Value - Limit Value.

Test Mode	IEEE 802.11a	Test Date	2022/9/14
Test Frequency	5180MHz	Polarization	Horizontal
Temp	25°C	Hum.	62%

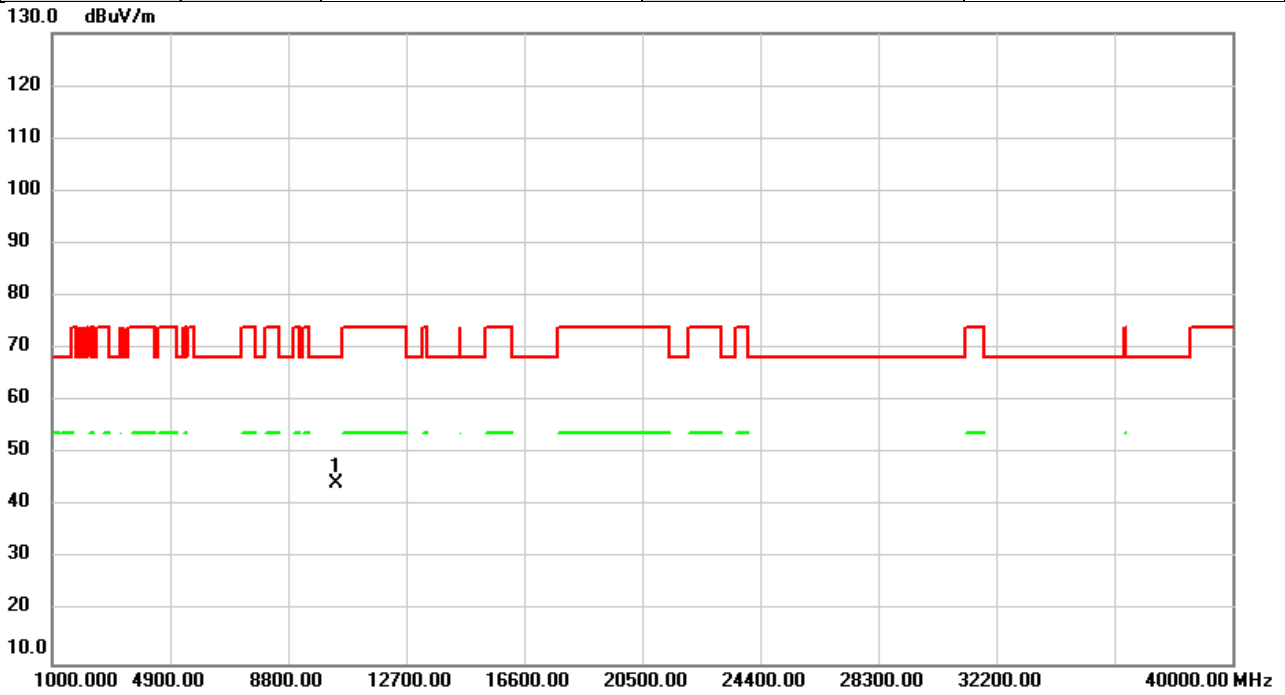

No.	Mk.	Freq.	Reading Level	Correct Factor	Measurement	Limit	Over	Detector	Comment
		MHz	dBuV	dB	dBuV/m	dBuV/m	dB		
1	*	10360.00	43.35	1.02	44.37	68.20	-23.83	peak	

REMARKS:

- (1) Measurement Value = Reading Level + Correct Factor.
- (2) Margin Level = Measurement Value - Limit Value.

Test Mode	IEEE 802.11a	Test Date	2022/9/14
Test Frequency	5200MHz	Polarization	Vertical
Temp	25°C	Hum.	62%

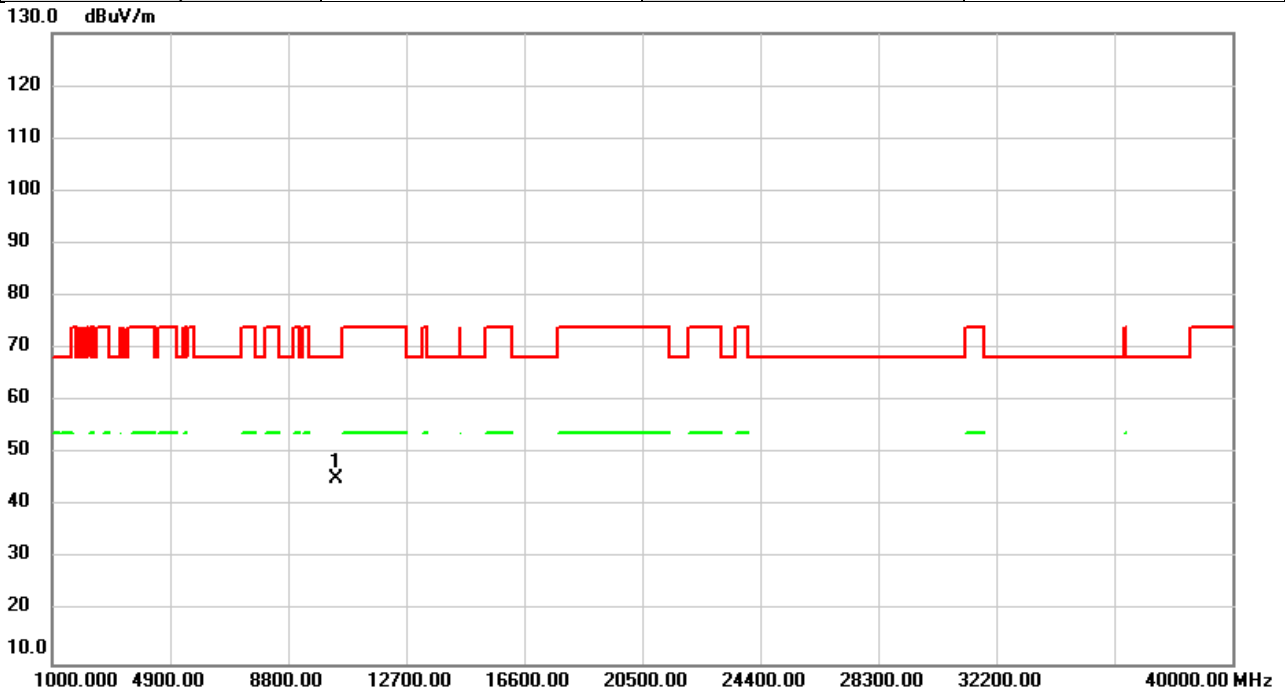

No.	Mk.	Freq.	Reading Level	Correct Factor	Measurement	Limit	Over	Detector	Comment
		MHz	dBuV	dB	dBuV/m	dBuV/m	dB		
1	*	10400.00	44.18	1.04	45.22	68.20	-22.98	peak	

REMARKS:

- (1) Measurement Value = Reading Level + Correct Factor.
- (2) Margin Level = Measurement Value - Limit Value.

Test Mode	IEEE 802.11a	Test Date	2022/9/14
Test Frequency	5200MHz	Polarization	Horizontal
Temp	25°C	Hum.	62%

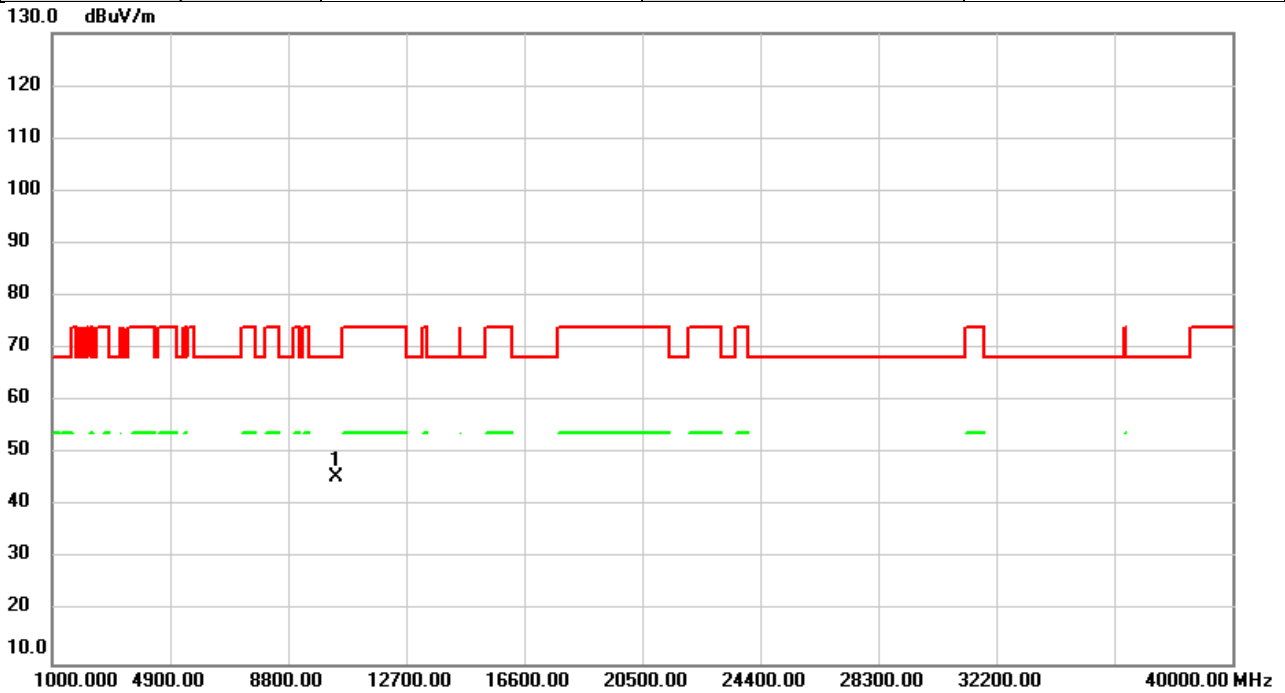

No.	Mk.	Freq.	Reading Level	Correct Factor	Measurement	Limit	Over	Detector	Comment
		MHz	dBuV	dB	dBuV/m	dBuV/m	dB		
1	*	10400.00	44.43	1.04	45.47	68.20	-22.73	peak	

REMARKS:

- (1) Measurement Value = Reading Level + Correct Factor.
- (2) Margin Level = Measurement Value - Limit Value.

Test Mode	IEEE 802.11a	Test Date	2022/9/14
Test Frequency	5240MHz	Polarization	Vertical
Temp	25°C	Hum.	62%

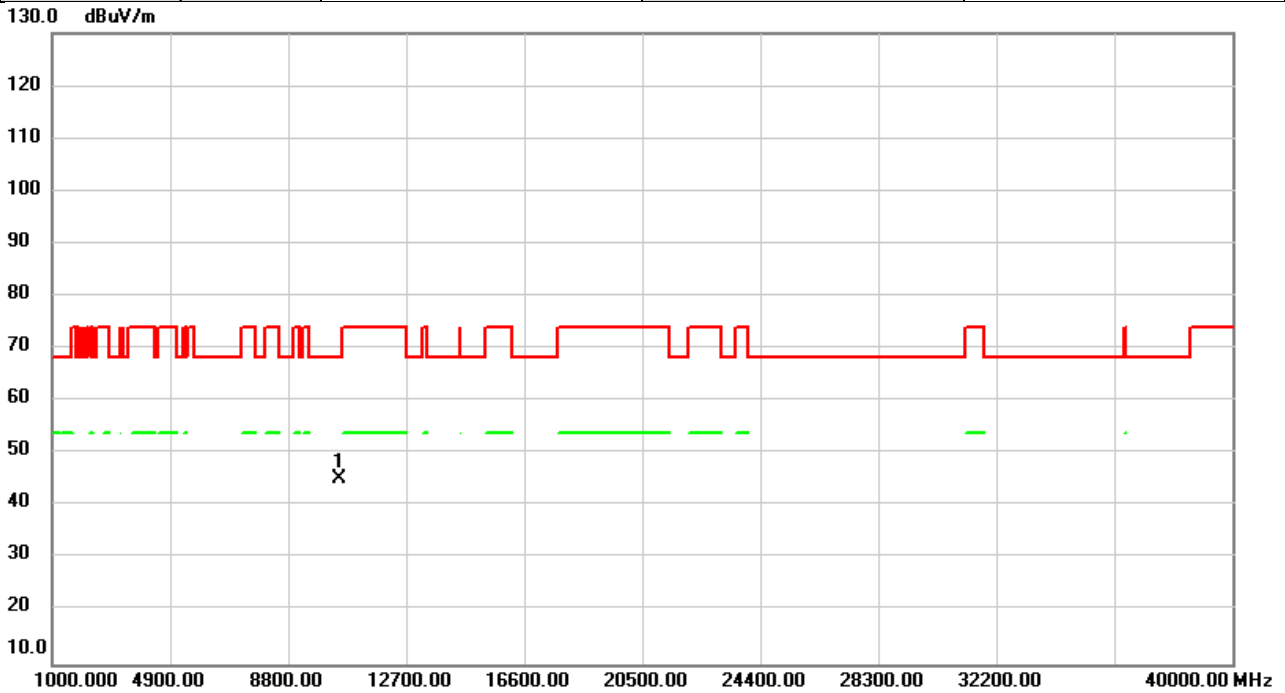

No.	Mk.	Freq.	Reading Level	Correct Factor	Measurement	Limit	Over	Detector	Comment
		MHz	dBuV	dB	dBuV/m	dBuV/m	dB		
1	*	10480.00	44.17	1.06	45.23	68.20	-22.97	peak	

REMARKS:

- (1) Measurement Value = Reading Level + Correct Factor.
- (2) Margin Level = Measurement Value - Limit Value.

Test Mode	IEEE 802.11a	Test Date	2022/9/14
Test Frequency	5240MHz	Polarization	Horizontal
Temp	25°C	Hum.	62%

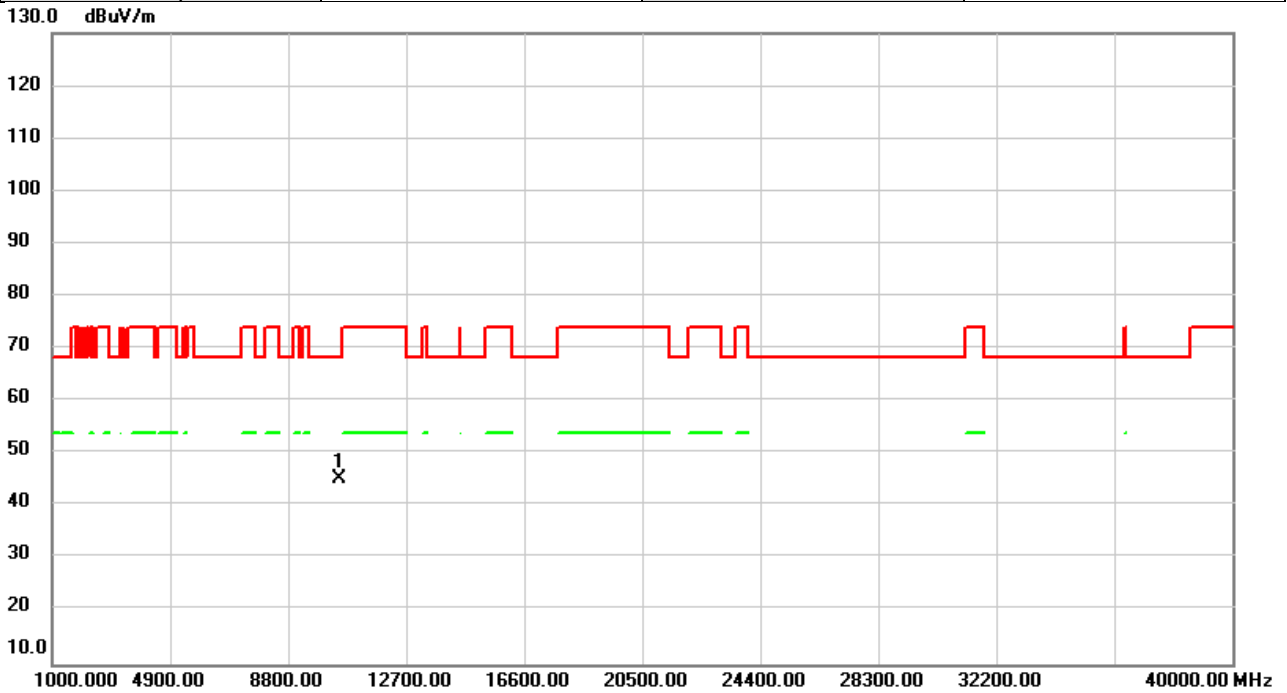

No.	Mk.	Freq.	Reading Level	Correct Factor	Measurement	Limit	Over	Detector	Comment
		MHz	dBuV	dB	dBuV/m	dBuV/m	dB		
1	*	10480.00	44.16	1.06	45.22	68.20	-22.98	peak	

REMARKS:

- (1) Measurement Value = Reading Level + Correct Factor.
- (2) Margin Level = Measurement Value - Limit Value.

Test Mode	IEEE 802.11a	Test Date	2022/9/14
Test Frequency	5260MHz	Polarization	Vertical
Temp	25°C	Hum.	62%

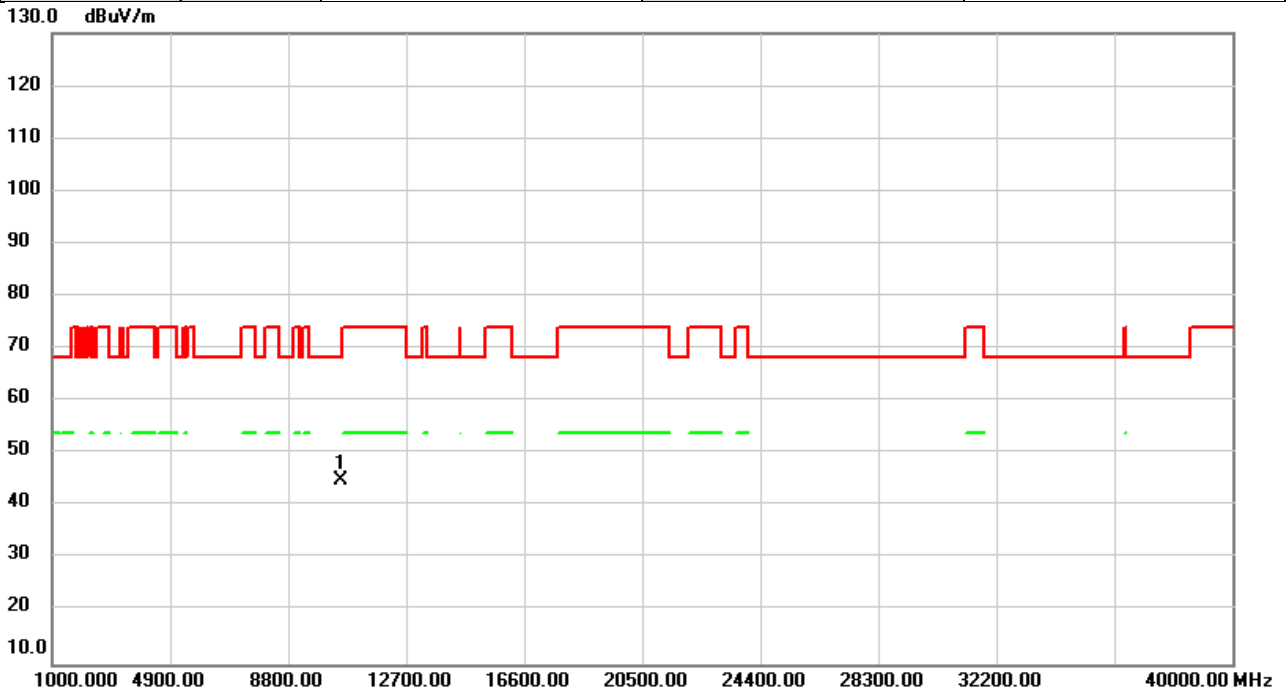

No.	Mk.	Freq.	Reading Level	Correct Factor	Measurement	Limit	Over	Detector	Comment
		MHz	dBuV	dB	dBuV/m	dBuV/m	dB		
1	*	10520.00	43.84	1.07	44.91	68.20	-23.29	peak	

REMARKS:

- (1) Measurement Value = Reading Level + Correct Factor.
- (2) Margin Level = Measurement Value - Limit Value.

Test Mode	IEEE 802.11a	Test Date	2022/9/14
Test Frequency	5260MHz	Polarization	Horizontal
Temp	25°C	Hum.	62%

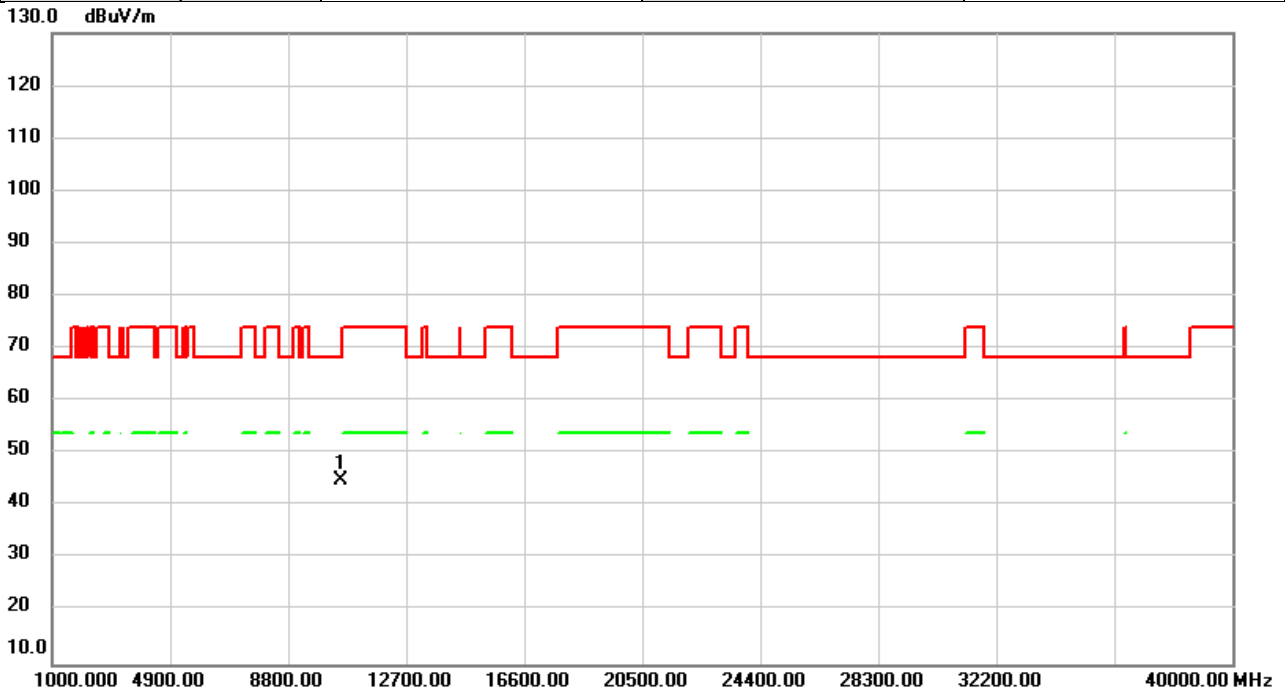

No.	Mk.	Freq.	Reading Level	Correct Factor	Measurement	Limit	Over	Detector	Comment
		MHz	dBuV	dB	dBuV/m	dBuV/m	dB		
1	*	10520.00	43.75	1.07	44.82	68.20	-23.38	peak	

REMARKS:

- (1) Measurement Value = Reading Level + Correct Factor.
- (2) Margin Level = Measurement Value - Limit Value.

Test Mode	IEEE 802.11a	Test Date	2022/9/14
Test Frequency	5300MHz	Polarization	Vertical
Temp	25°C	Hum.	62%

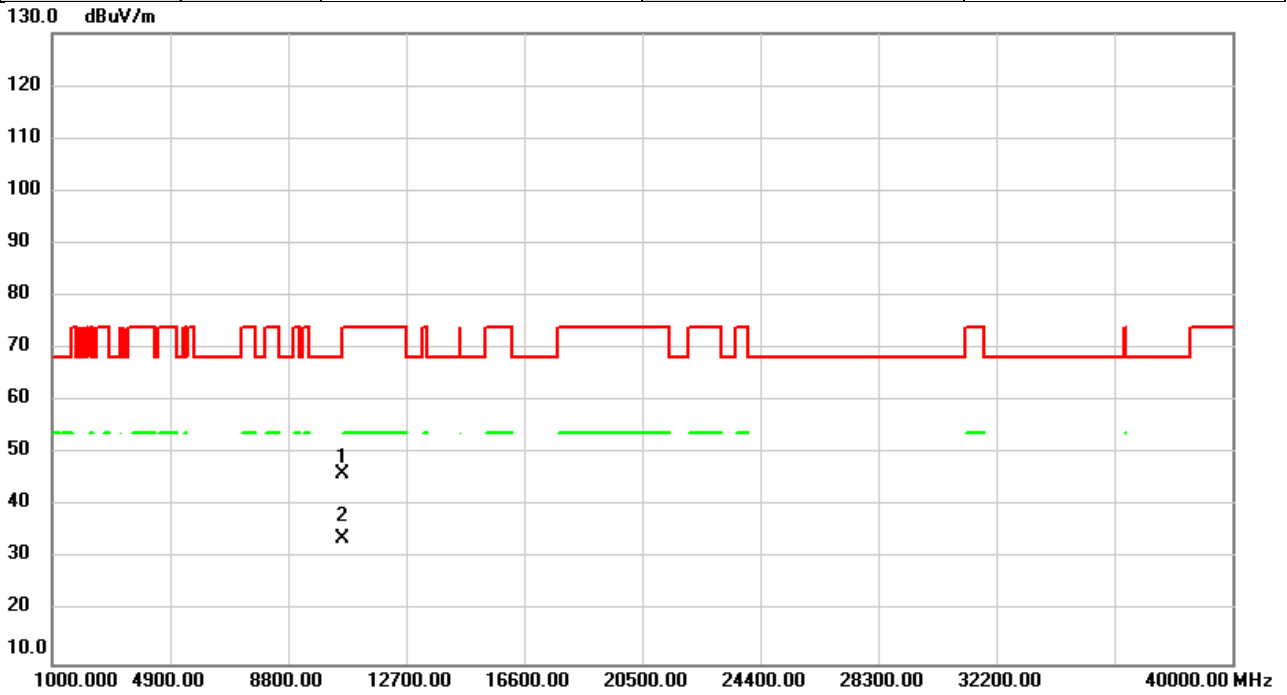

No.	Mk.	Freq. MHz	Reading Level dBuV	Correct Factor dB	Measure- ment dBuV/m	Limit dBuV/m	Over dB	Detector	Comment
1		10600.00	45.05	1.09	46.14	68.20	-22.06	peak	
2	*	10600.00	32.72	1.09	33.81	54.00	-20.19	AVG	

REMARKS:

- (1) Measurement Value = Reading Level + Correct Factor.
- (2) Margin Level = Measurement Value - Limit Value.

Test Mode	IEEE 802.11a	Test Date	2022/9/14
Test Frequency	5300MHz	Polarization	Horizontal
Temp	25°C	Hum.	62%

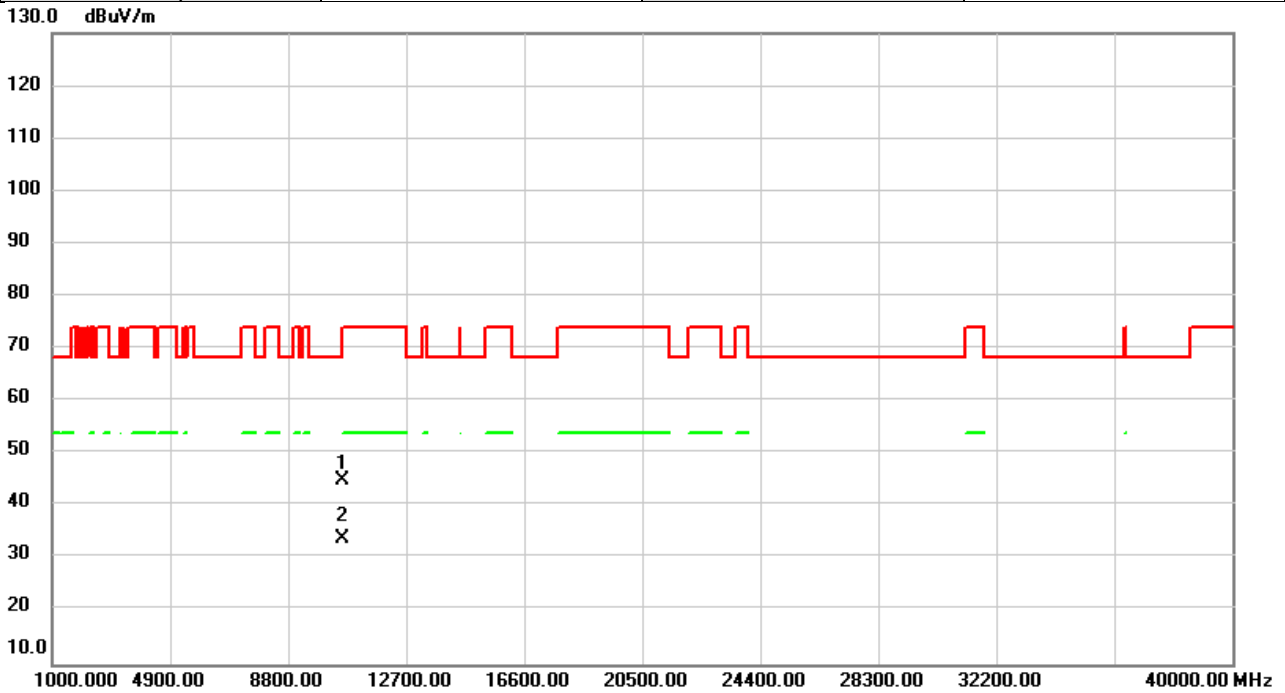

No.	Mk.	Freq.	Reading Level	Correct Factor	Measurement	Limit	Over	Detector	Comment
		MHz	dBuV	dB	dBuV/m	dBuV/m	dB		
1		10600.00	43.99	1.09	45.08	68.20	-23.12	peak	
2	*	10600.00	32.71	1.09	33.80	54.00	-20.20	AVG	

REMARKS:

- (1) Measurement Value = Reading Level + Correct Factor.
- (2) Margin Level = Measurement Value - Limit Value.

Test Mode	IEEE 802.11a	Test Date	2022/9/14
Test Frequency	5320MHz	Polarization	Vertical
Temp	25°C	Hum.	62%

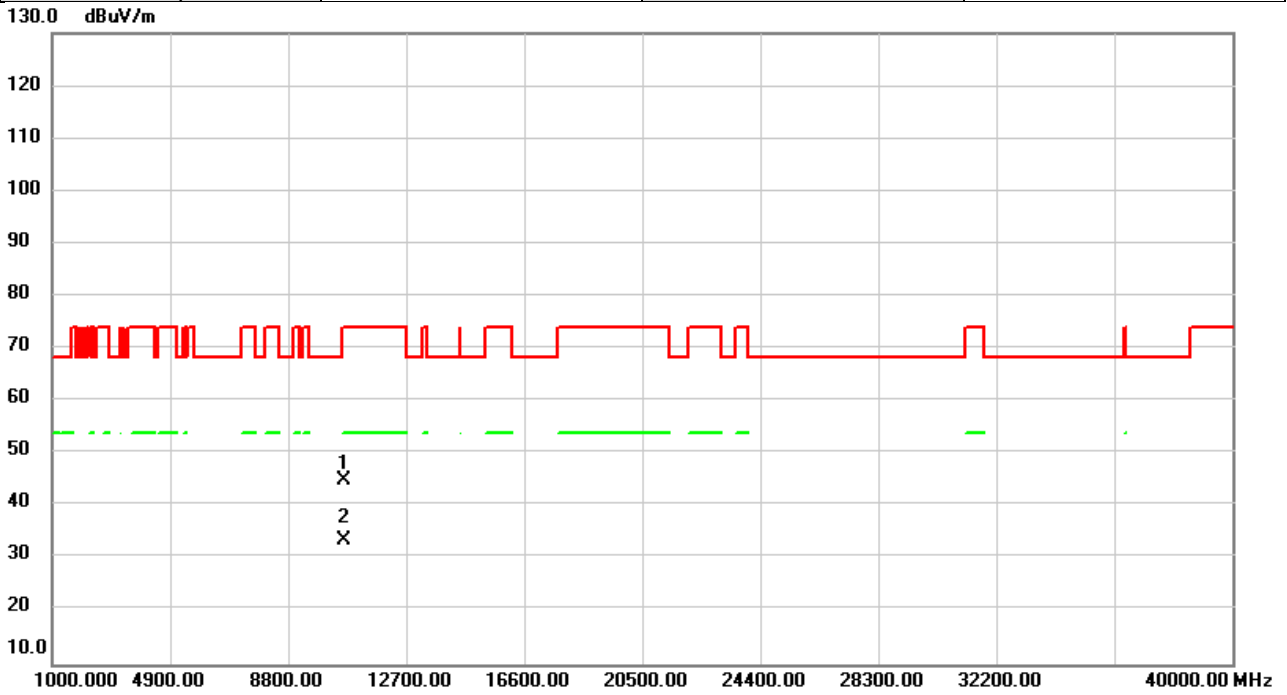

No.	Mk.	Freq. MHz	Reading Level dBuV	Correct Factor dB	Measure- ment dBuV/m	Limit dBuV/m	Over dB	Detector	Comment
1		10640.00	43.79	1.10	44.89	74.00	-29.11	peak	
2	*	10640.00	32.38	1.10	33.48	54.00	-20.52	AVG	

REMARKS:

- (1) Measurement Value = Reading Level + Correct Factor.
- (2) Margin Level = Measurement Value - Limit Value.

Test Mode	IEEE 802.11a	Test Date	2022/9/14
Test Frequency	5320MHz	Polarization	Horizontal
Temp	25°C	Hum.	62%

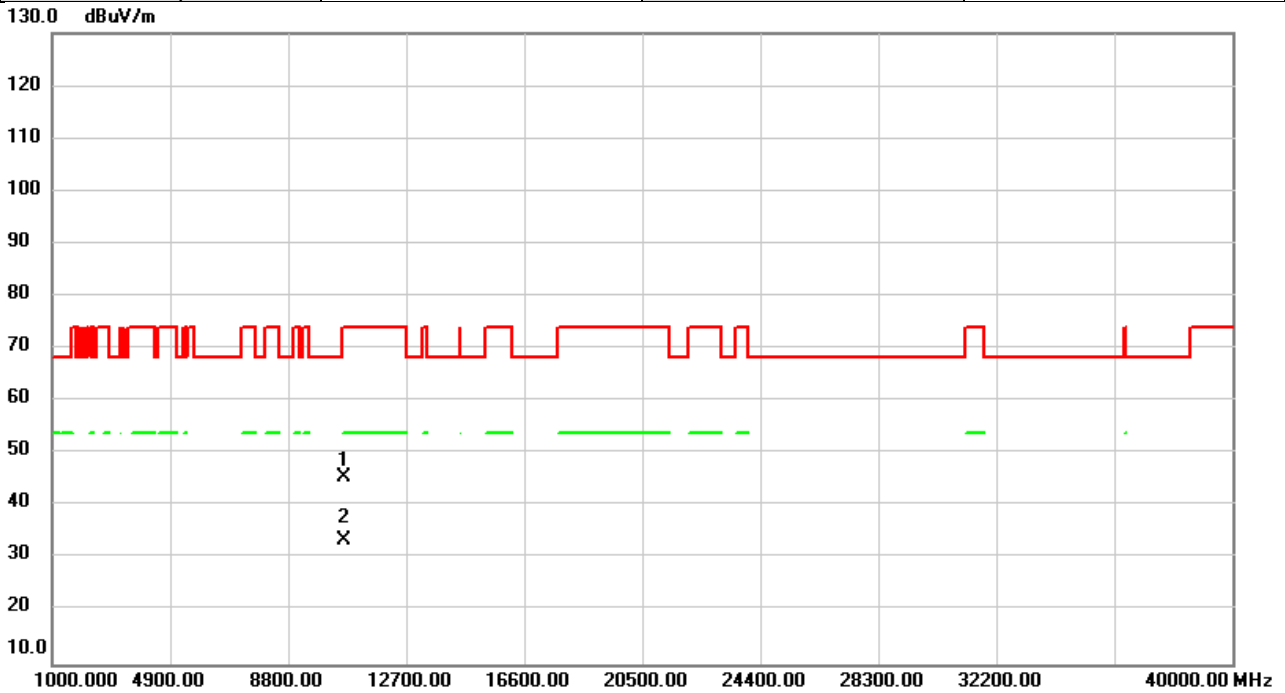

No.	Mk.	Freq. MHz	Reading Level dBuV	Correct Factor dB	Measure- ment dBuV/m	Limit dBuV/m	Over dB	Detector	Comment
1		10640.00	44.37	1.10	45.47	74.00	-28.53	peak	
2	*	10640.00	32.33	1.10	33.43	54.00	-20.57	AVG	

REMARKS:

- (1) Measurement Value = Reading Level + Correct Factor.
- (2) Margin Level = Measurement Value - Limit Value.

Test Mode	IEEE 802.11a	Test Date	2022/9/14
Test Frequency	5500MHz	Polarization	Vertical
Temp	25°C	Hum.	62%

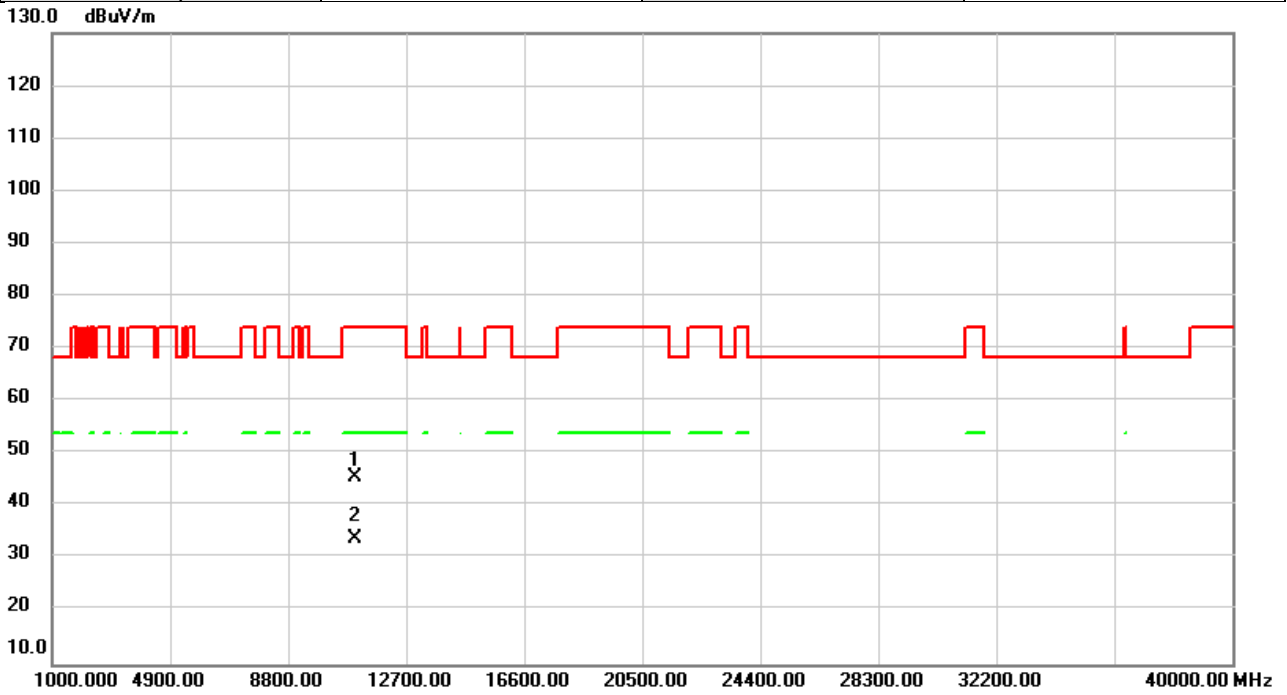

No.	Mk.	Freq. MHz	Reading Level dBuV	Correct Factor dB	Measure- ment dBuV/m	Limit dBuV/m	Over dB	Detector	Comment
1		11000.00	44.46	1.21	45.67	74.00	-28.33	peak	
2	*	11000.00	32.55	1.21	33.76	54.00	-20.24	AVG	

REMARKS:

- (1) Measurement Value = Reading Level + Correct Factor.
- (2) Margin Level = Measurement Value - Limit Value.

Test Mode	IEEE 802.11a	Test Date	2022/9/14
Test Frequency	5500MHz	Polarization	Horizontal
Temp	25°C	Hum.	62%

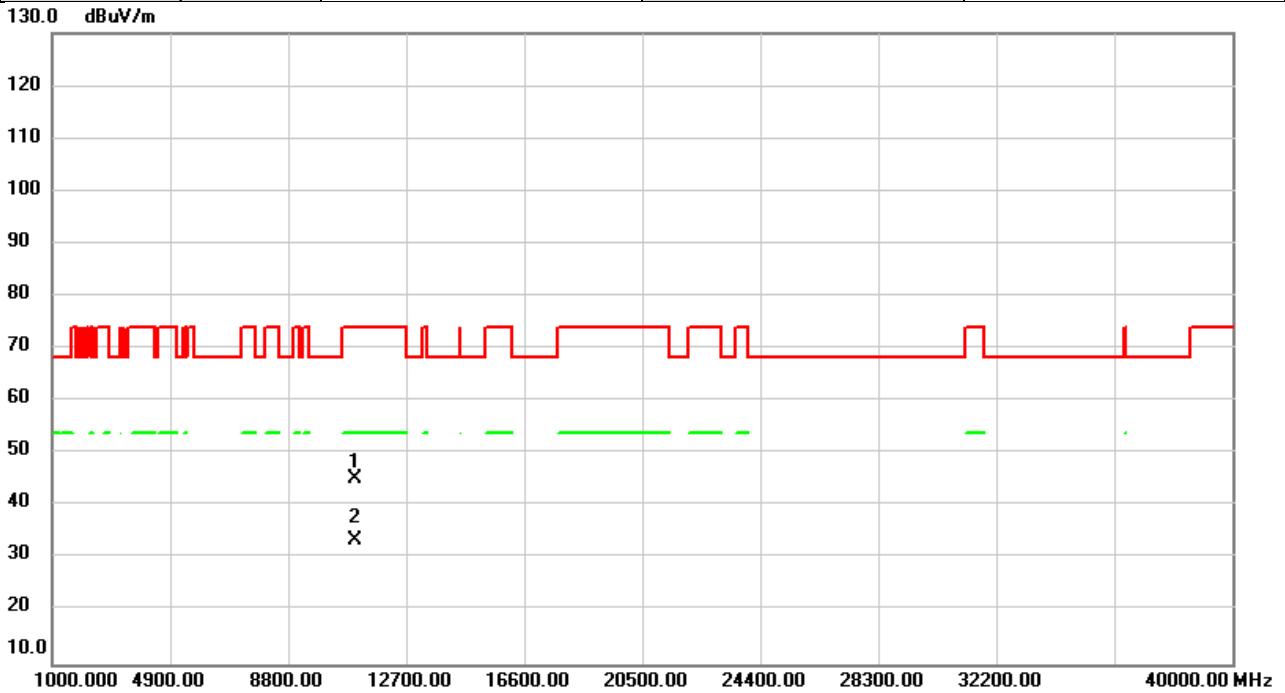

No.	Mk.	Freq. MHz	Reading Level dBuV	Correct Factor dB	Measure- ment dBuV/m	Limit dBuV/m	Over dB	Detector	Comment
1		11000.00	44.15	1.21	45.36	74.00	-28.64	peak	
2	*	11000.00	32.45	1.21	33.66	54.00	-20.34	AVG	

REMARKS:

- (1) Measurement Value = Reading Level + Correct Factor.
- (2) Margin Level = Measurement Value - Limit Value.

Test Mode	IEEE 802.11a	Test Date	2022/9/14
Test Frequency	5580MHz	Polarization	Vertical
Temp	25°C	Hum.	62%

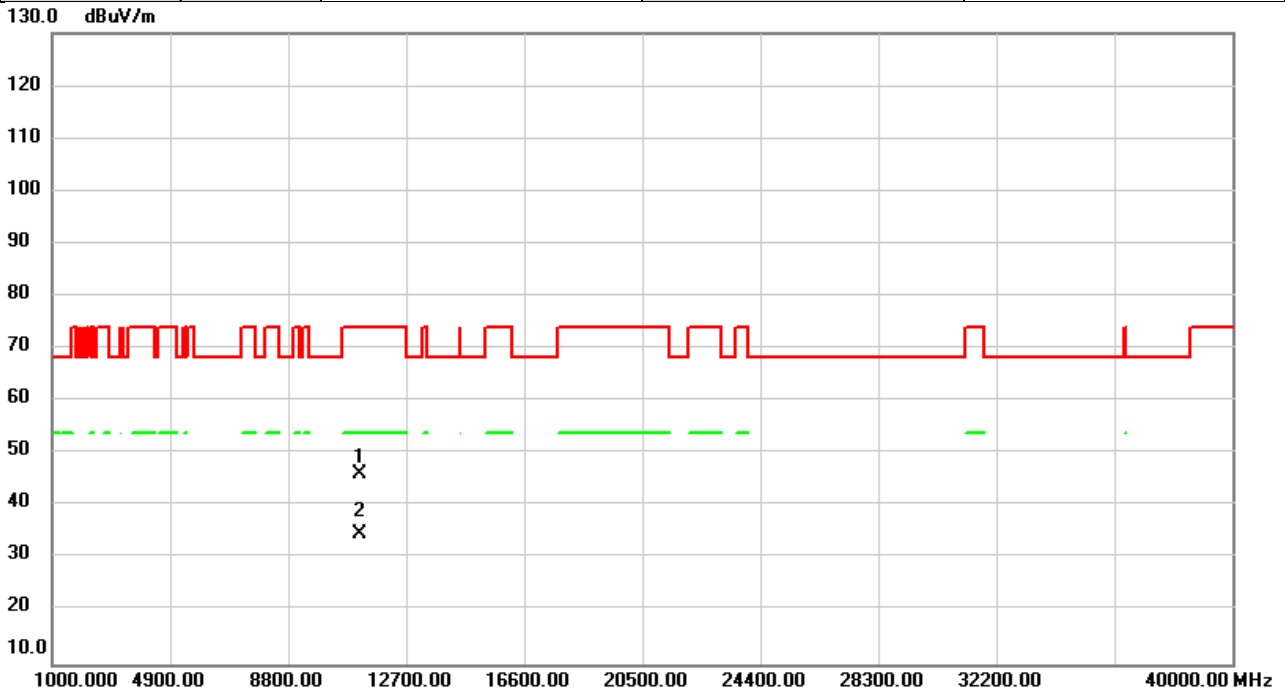

No.	Mk.	Freq. MHz	Reading Level dBuV	Correct Factor dB	Measure- ment dBuV/m	Limit dBuV/m	Over dB	Detector	Comment
1		11160.00	44.33	1.68	46.01	74.00	-27.99	peak	
2	*	11160.00	32.98	1.68	34.66	54.00	-19.34	AVG	

REMARKS:

- (1) Measurement Value = Reading Level + Correct Factor.
- (2) Margin Level = Measurement Value - Limit Value.

Test Mode	IEEE 802.11a	Test Date	2022/9/14
Test Frequency	5580MHz	Polarization	Horizontal
Temp	25°C	Hum.	62%

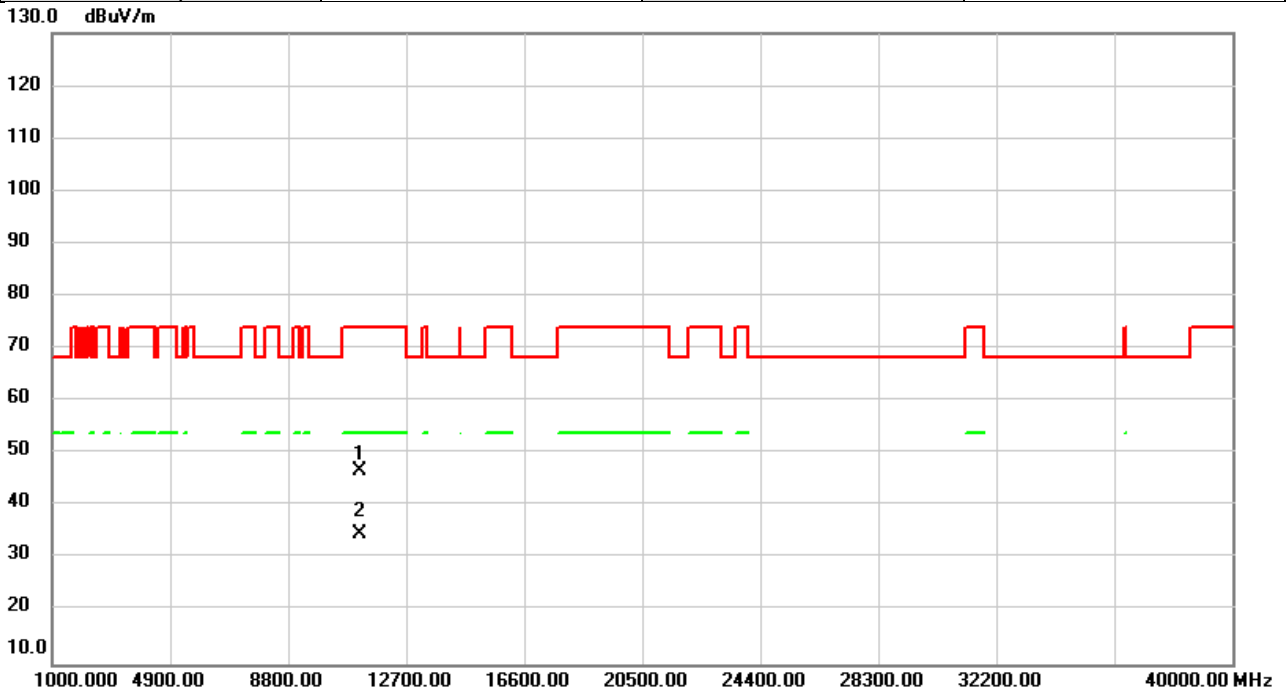

No.	Mk.	Freq. MHz	Reading Level dBuV	Correct Factor dB	Measure- ment dBuV/m	Limit dBuV/m	Over dB	Detector	Comment
1		11160.00	45.20	1.68	46.88	74.00	-27.12	peak	
2	*	11160.00	33.05	1.68	34.73	54.00	-19.27	AVG	

REMARKS:

- (1) Measurement Value = Reading Level + Correct Factor.
- (2) Margin Level = Measurement Value - Limit Value.

Test Mode	IEEE 802.11a	Test Date	2022/9/14
Test Frequency	5700MHz	Polarization	Vertical
Temp	25°C	Hum.	62%

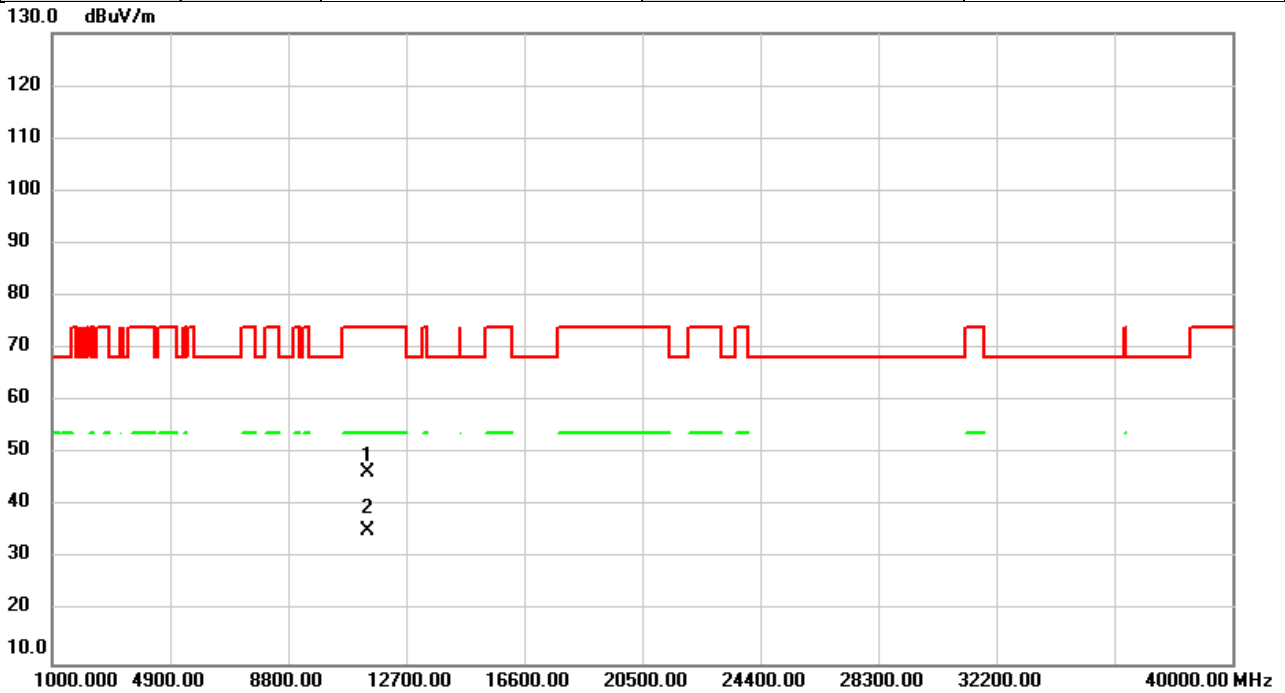

No.	Mk.	Freq. MHz	Reading Level dBuV	Correct Factor dB	Measure- ment dBuV/m	Limit dBuV/m	Over dB	Detector	Comment
1		11400.00	44.21	2.36	46.57	74.00	-27.43	peak	
2	*	11400.00	32.85	2.36	35.21	54.00	-18.79	AVG	

REMARKS:

- (1) Measurement Value = Reading Level + Correct Factor.
- (2) Margin Level = Measurement Value - Limit Value.

Test Mode	IEEE 802.11a	Test Date	2022/9/14
Test Frequency	5700MHz	Polarization	Horizontal
Temp	25°C	Hum.	62%

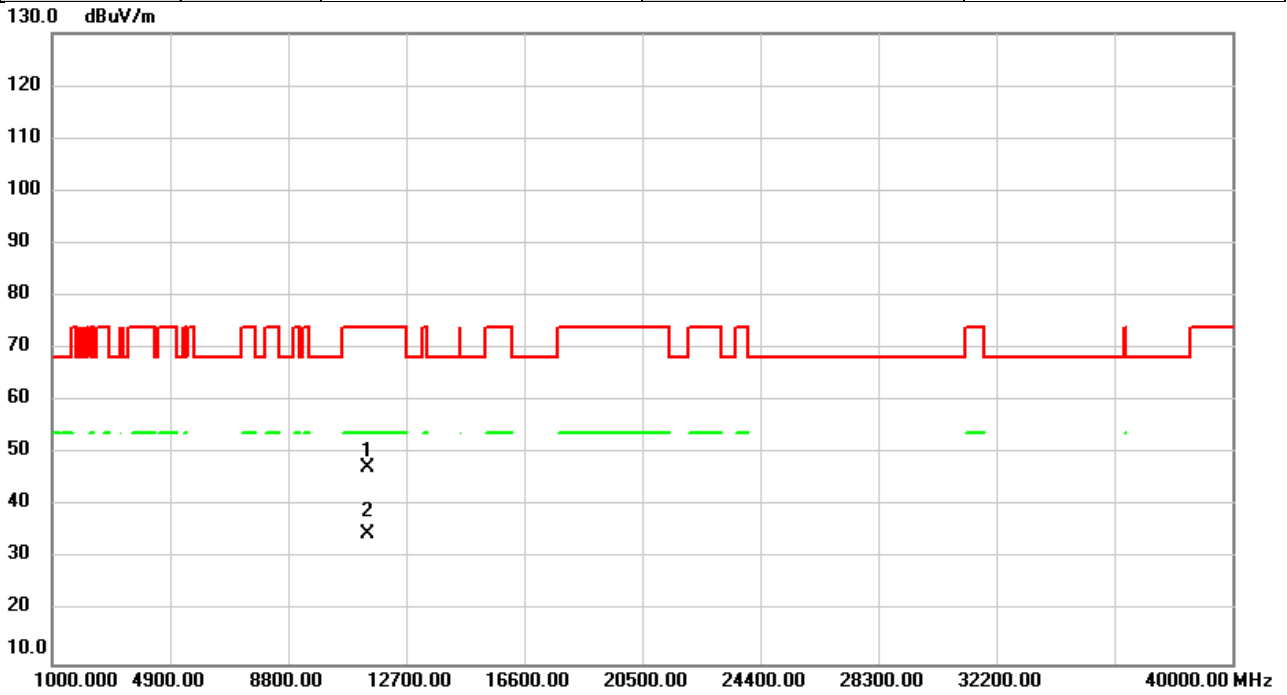

No.	Mk.	Freq. MHz	Reading Level dBuV	Correct Factor dB	Measure- ment dBuV/m	Limit dBuV/m	Over dB	Detector	Comment
1		11400.00	45.13	2.36	47.49	74.00	-26.51	peak	
2	*	11400.00	32.47	2.36	34.83	54.00	-19.17	AVG	

REMARKS:

- (1) Measurement Value = Reading Level + Correct Factor.
- (2) Margin Level = Measurement Value - Limit Value.

Test Mode	IEEE 802.11a	Test Date	2022/9/14
Test Frequency	5720MHz	Polarization	Vertical
Temp	25°C	Hum.	62%

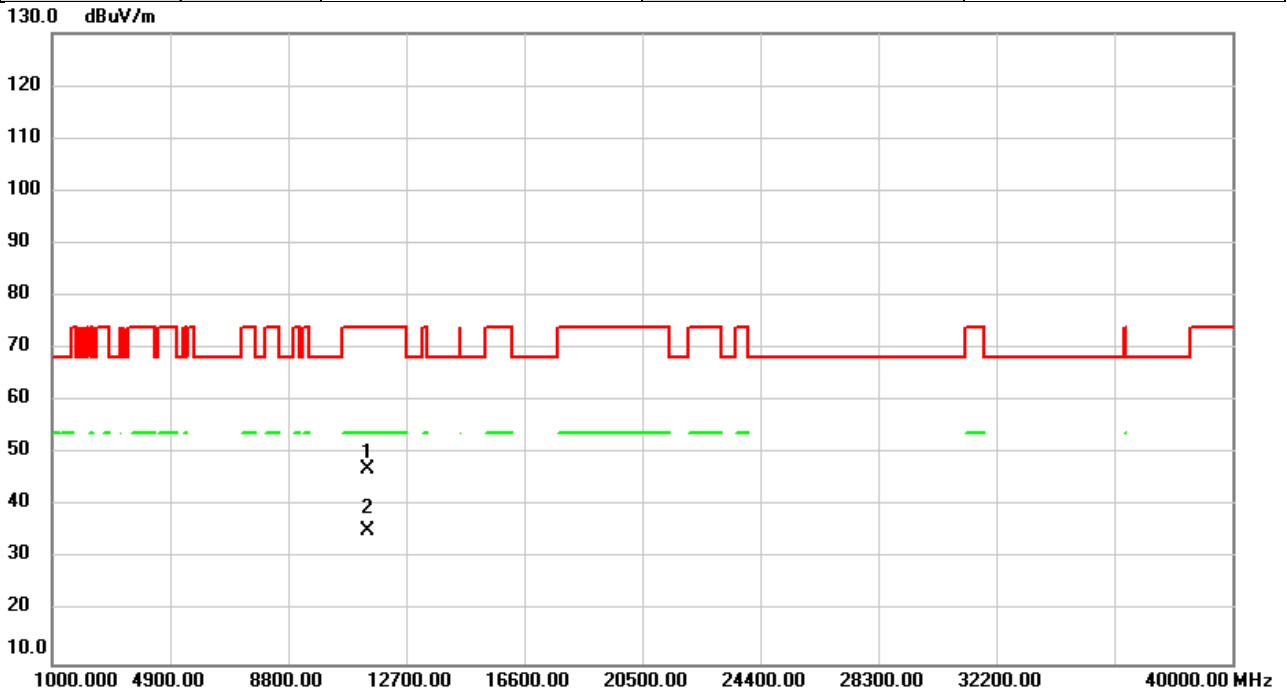

No.	Mk.	Freq. MHz	Reading Level dBuV	Correct Factor dB	Measure- ment dBuV/m	Limit dBuV/m	Over dB	Detector	Comment
1		11440.00	44.65	2.47	47.12	74.00	-26.88	peak	
2	*	11440.00	32.74	2.47	35.21	54.00	-18.79	AVG	

REMARKS:

- (1) Measurement Value = Reading Level + Correct Factor.
- (2) Margin Level = Measurement Value - Limit Value.

Test Mode	IEEE 802.11a	Test Date	2022/9/14
Test Frequency	5720MHz	Polarization	Horizontal
Temp	25°C	Hum.	62%

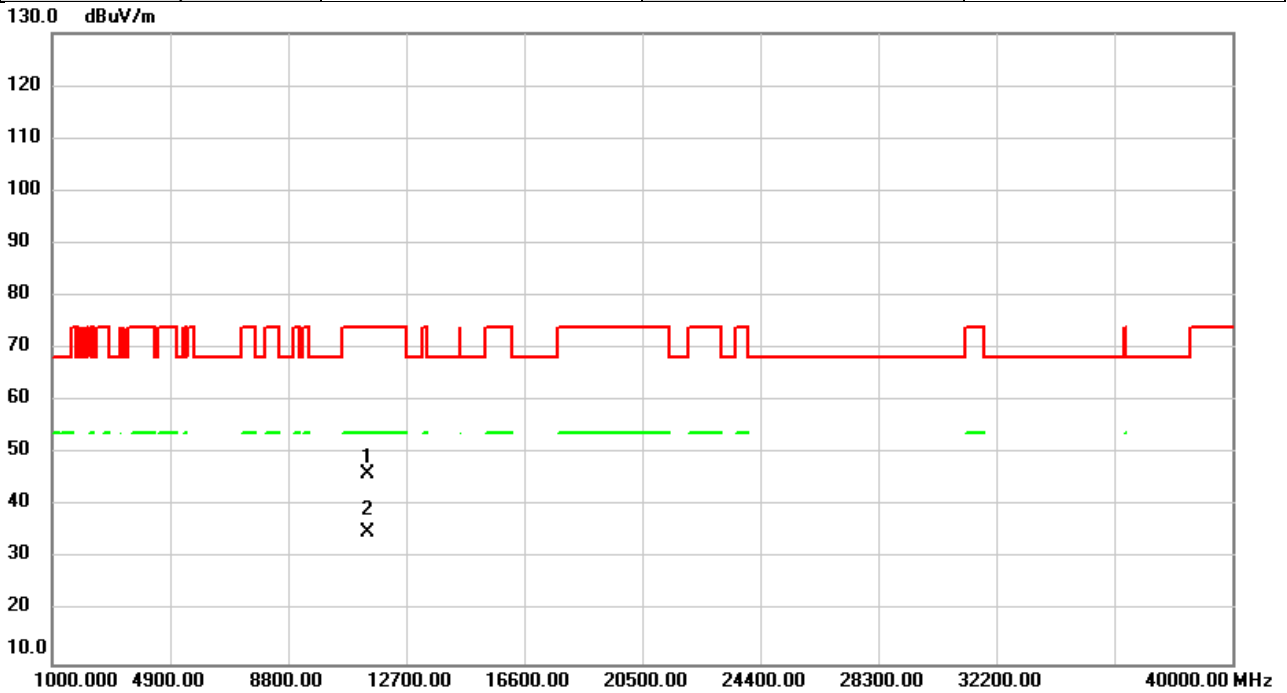

No.	Mk.	Freq.	Reading Level	Correct Factor	Measurement	Limit	Over	Detector	Comment
		MHz	dBuV	dB	dBuV/m	dBuV/m	dB		
1		11440.00	43.55	2.47	46.02	74.00	-27.98	peak	
2	*	11440.00	32.65	2.47	35.12	54.00	-18.88	AVG	

REMARKS:

- (1) Measurement Value = Reading Level + Correct Factor.
- (2) Margin Level = Measurement Value - Limit Value.

Test Mode	IEEE 802.11ac (VHT20)	Test Date	2022/9/14
Test Frequency	5180MHz	Polarization	Vertical
Temp	25°C	Hum.	62%

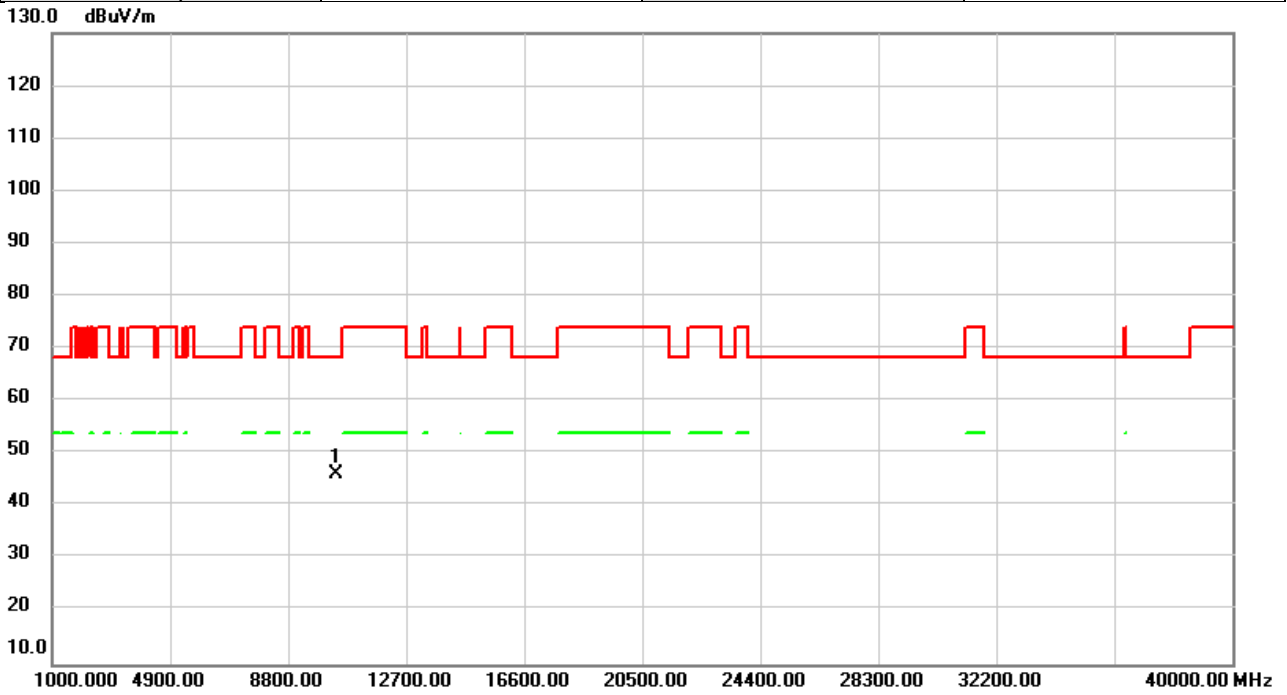

No.	Mk.	Freq. MHz	Reading Level dBuV	Correct Factor dB	Measure- ment dBuV/m	Limit dBuV/m	Over dB	Detector	Comment
1	*	10360.00	45.26	1.02	46.28	68.20	-21.92	peak	

REMARKS:

- (1) Measurement Value = Reading Level + Correct Factor.
- (2) Margin Level = Measurement Value - Limit Value.

Test Mode	IEEE 802.11ac (VHT20)	Test Date	2022/9/14
Test Frequency	5180MHz	Polarization	Horizontal
Temp	25°C	Hum.	62%

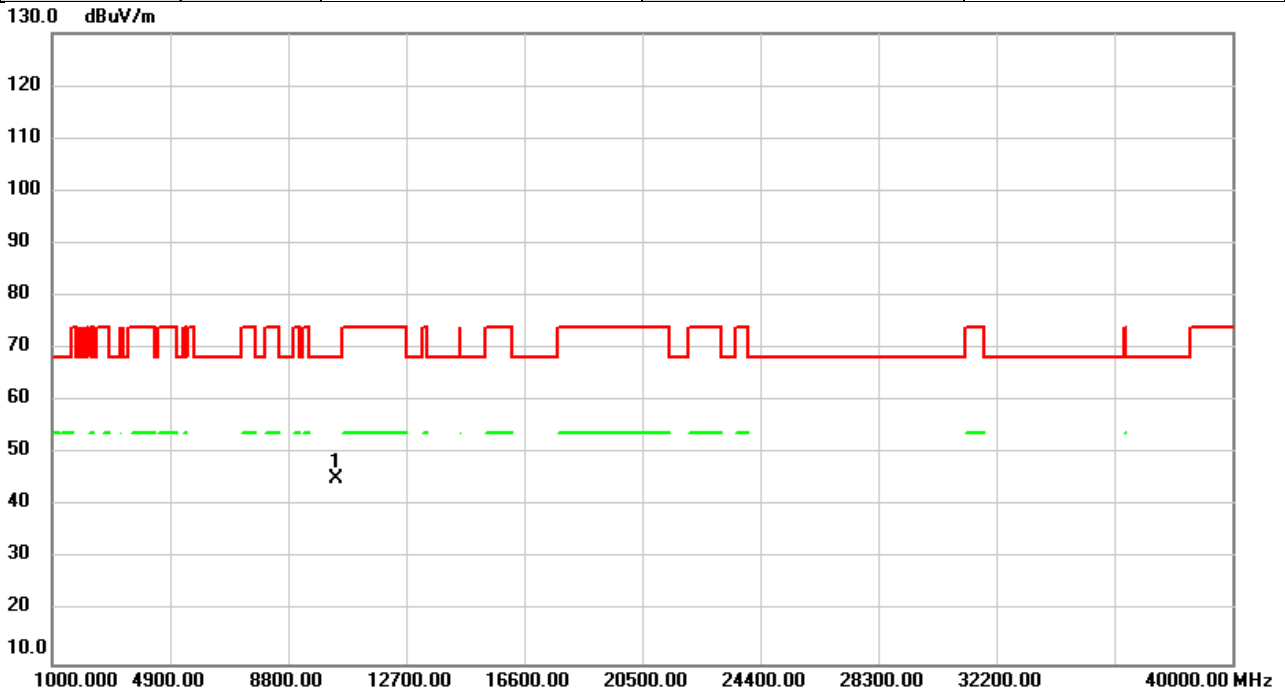

No.	Mk.	Freq. MHz	Reading Level dBuV	Correct Factor dB	Measure- ment dBuV/m	Limit dBuV/m	Over dB	Detector	Comment
1	*	10360.00	44.16	1.02	45.18	68.20	-23.02	peak	

REMARKS:

- (1) Measurement Value = Reading Level + Correct Factor.
- (2) Margin Level = Measurement Value - Limit Value.

Test Mode	IEEE 802.11ac (VHT20)	Test Date	2022/9/14
Test Frequency	5200MHz	Polarization	Vertical
Temp	25°C	Hum.	62%

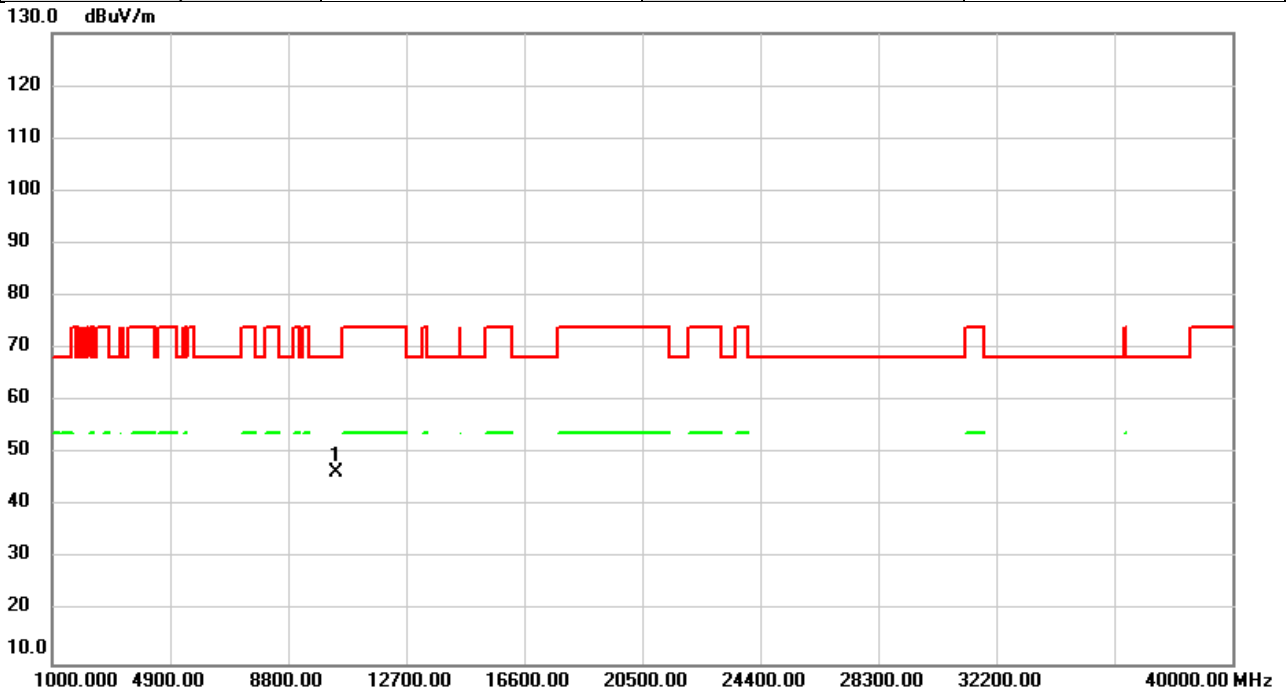

No.	Mk.	Freq. MHz	Reading Level dBuV	Correct Factor dB	Measure- ment dBuV/m	Limit dBuV/m	Over dB	Detector	Comment
1	*	10400.00	45.32	1.04	46.36	68.20	-21.84	peak	

REMARKS:

- (1) Measurement Value = Reading Level + Correct Factor.
- (2) Margin Level = Measurement Value - Limit Value.

Test Mode	IEEE 802.11ac (VHT20)	Test Date	2022/9/14
Test Frequency	5200MHz	Polarization	Horizontal
Temp	25°C	Hum.	62%

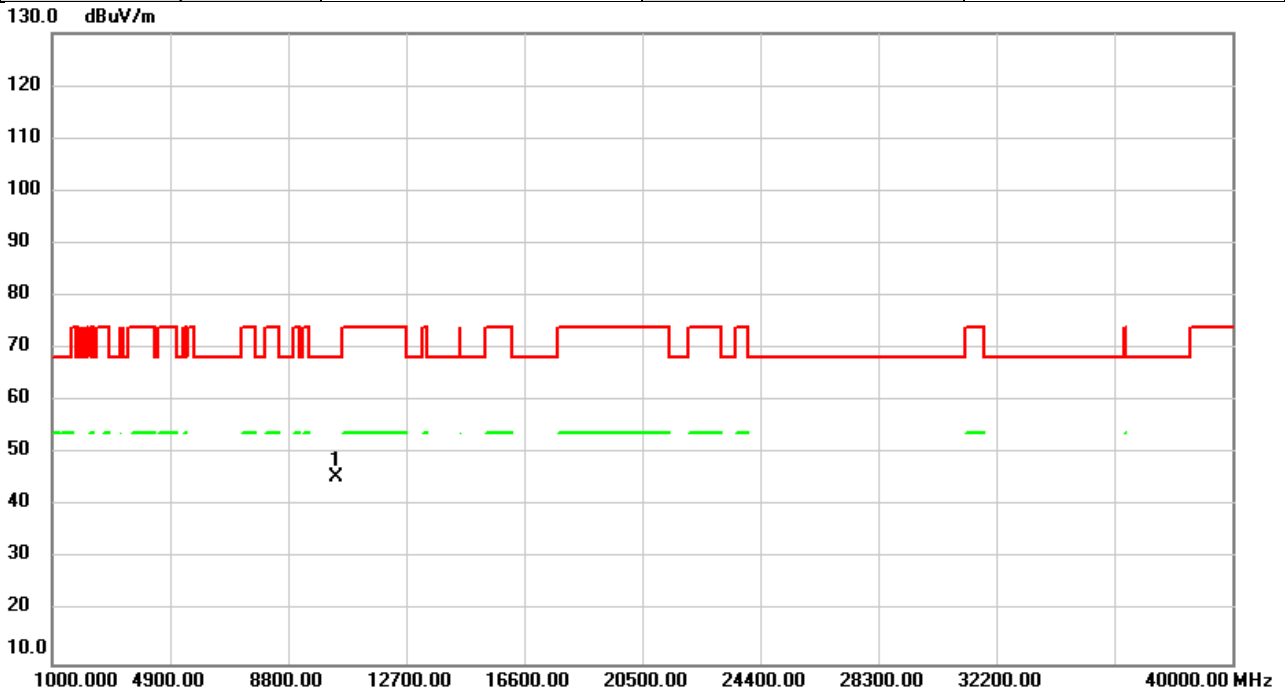

No.	Mk.	Freq.	Reading Level	Correct Factor	Measurement	Limit	Over	Detector	Comment
		MHz	dBuV	dB	dBuV/m	dBuV/m	dB		
1	*	10400.00	44.53	1.04	45.57	68.20	-22.63	peak	

REMARKS:

- (1) Measurement Value = Reading Level + Correct Factor.
- (2) Margin Level = Measurement Value - Limit Value.

Test Mode	IEEE 802.11ac (VHT20)	Test Date	2022/9/14
Test Frequency	5240MHz	Polarization	Vertical
Temp	25°C	Hum.	62%

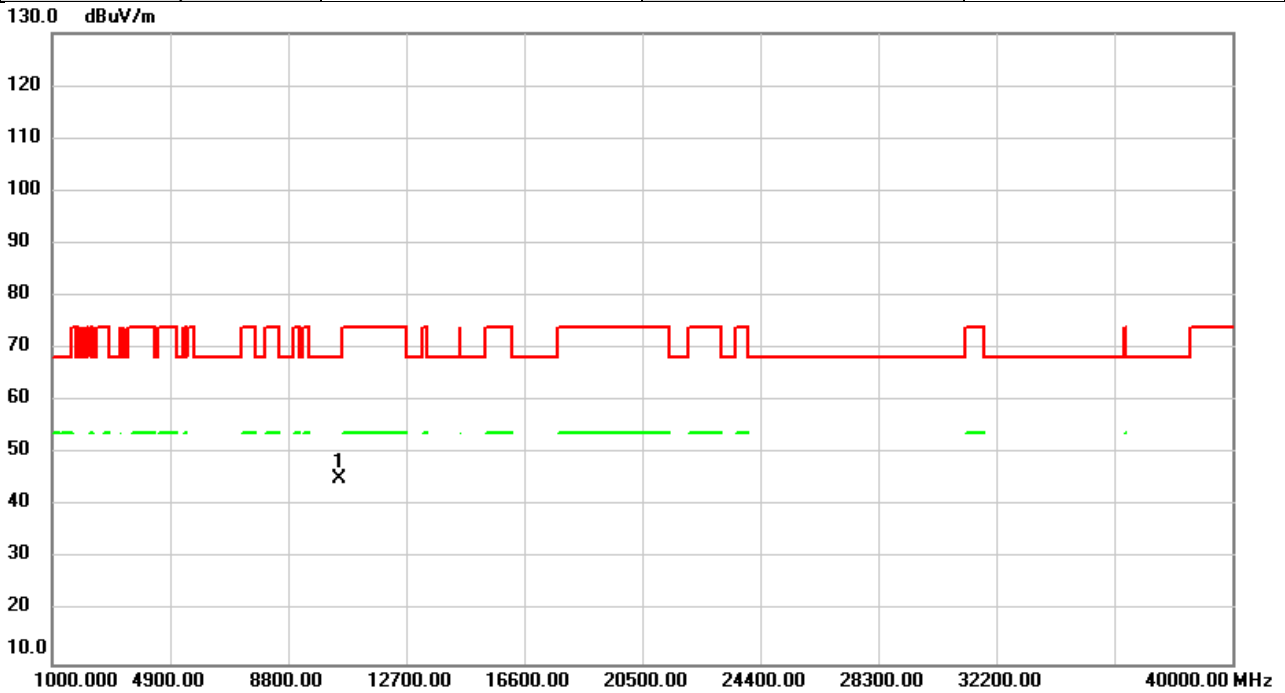

No.	Mk.	Freq. MHz	Reading Level dBuV	Correct Factor dB	Measure- ment dBuV/m	Limit dBuV/m	Over dB	Detector	Comment
1	*	10480.00	44.34	1.06	45.40	68.20	-22.80	peak	

REMARKS:

- (1) Measurement Value = Reading Level + Correct Factor.
- (2) Margin Level = Measurement Value - Limit Value.

Test Mode	IEEE 802.11ac (VHT20)	Test Date	2022/9/14
Test Frequency	5240MHz	Polarization	Horizontal
Temp	25°C	Hum.	62%

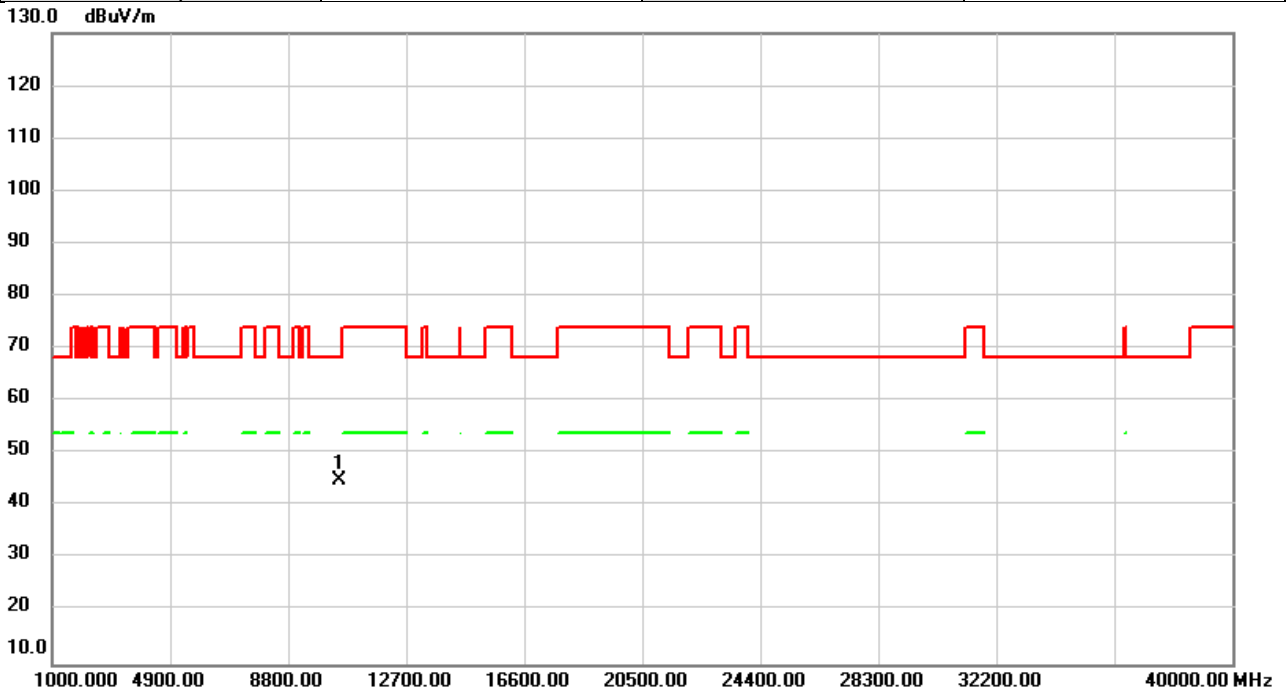

No.	Mk.	Freq.	Reading Level	Correct Factor	Measurement	Limit	Over	Detector	Comment
		MHz	dBuV	dB	dBuV/m	dBuV/m	dB		
1	*	10480.00	43.84	1.06	44.90	68.20	-23.30	peak	

REMARKS:

- (1) Measurement Value = Reading Level + Correct Factor.
- (2) Margin Level = Measurement Value - Limit Value.

Test Mode	IEEE 802.11ac (VHT20)	Test Date	2022/9/14
Test Frequency	5260MHz	Polarization	Vertical
Temp	25°C	Hum.	62%

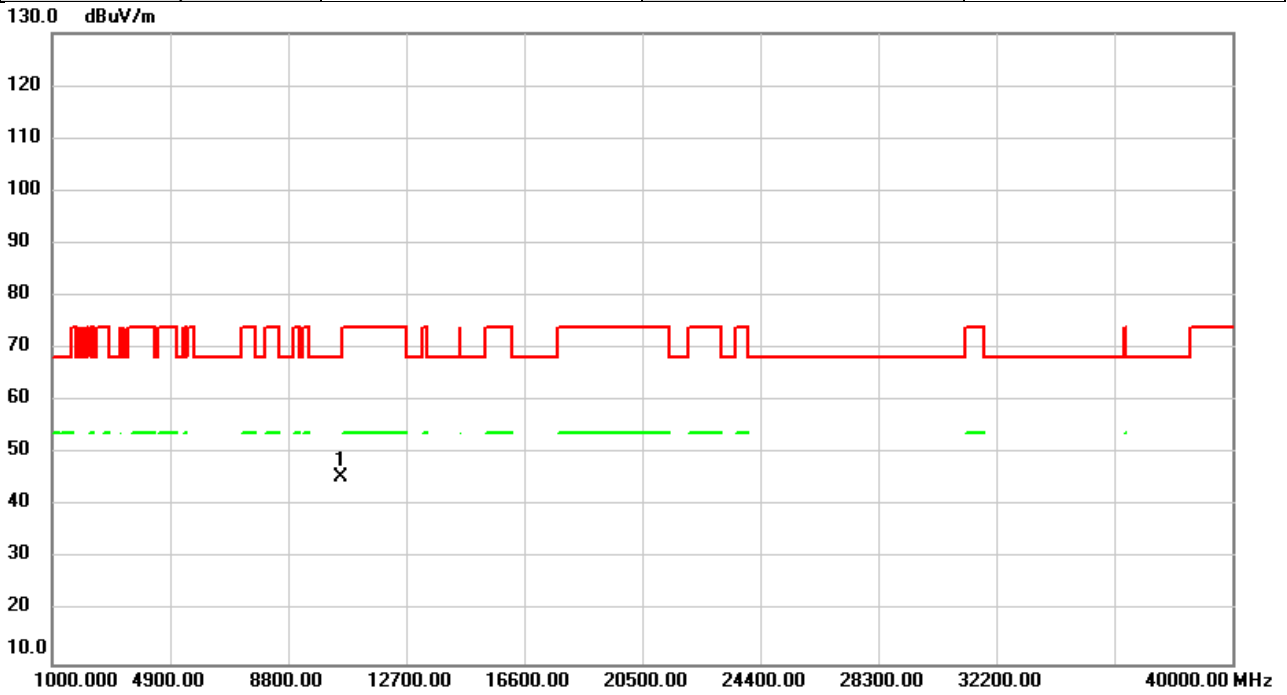

No.	Mk.	Freq. MHz	Reading Level dBuV	Correct Factor dB	Measure- ment dBuV/m	Limit dBuV/m	Over dB	Detector	Comment
1	*	10520.00	44.60	1.07	45.67	68.20	-22.53	peak	

REMARKS:

- (1) Measurement Value = Reading Level + Correct Factor.
- (2) Margin Level = Measurement Value - Limit Value.

Test Mode	IEEE 802.11ac (VHT20)	Test Date	2022/9/14
Test Frequency	5260MHz	Polarization	Horizontal
Temp	25°C	Hum.	62%

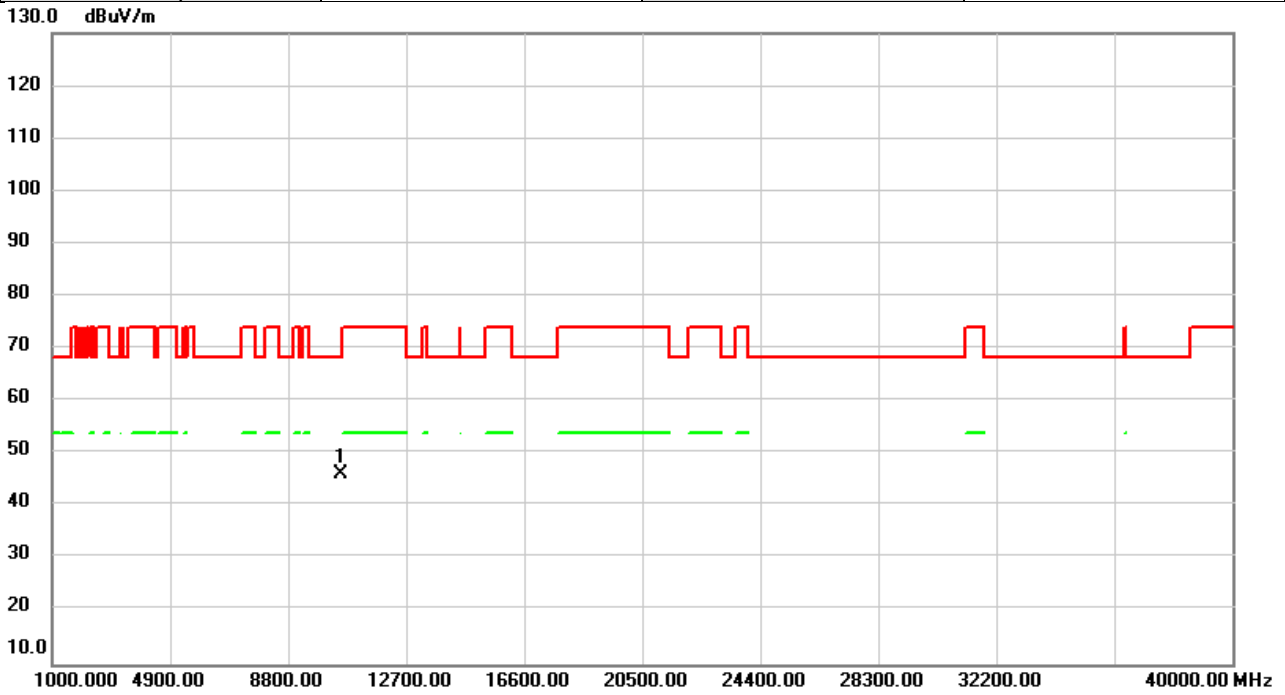

No.	Mk.	Freq.	Reading Level	Correct Factor	Measurement	Limit	Over	Detector	Comment
		MHz	dBuV	dB	dBuV/m	dBuV/m	dB		
1	*	10520.00	45.20	1.07	46.27	68.20	-21.93	peak	

REMARKS:

- (1) Measurement Value = Reading Level + Correct Factor.
- (2) Margin Level = Measurement Value - Limit Value.

Test Mode	IEEE 802.11ac (VHT20)	Test Date	2022/9/14
Test Frequency	5300MHz	Polarization	Vertical
Temp	25°C	Hum.	62%

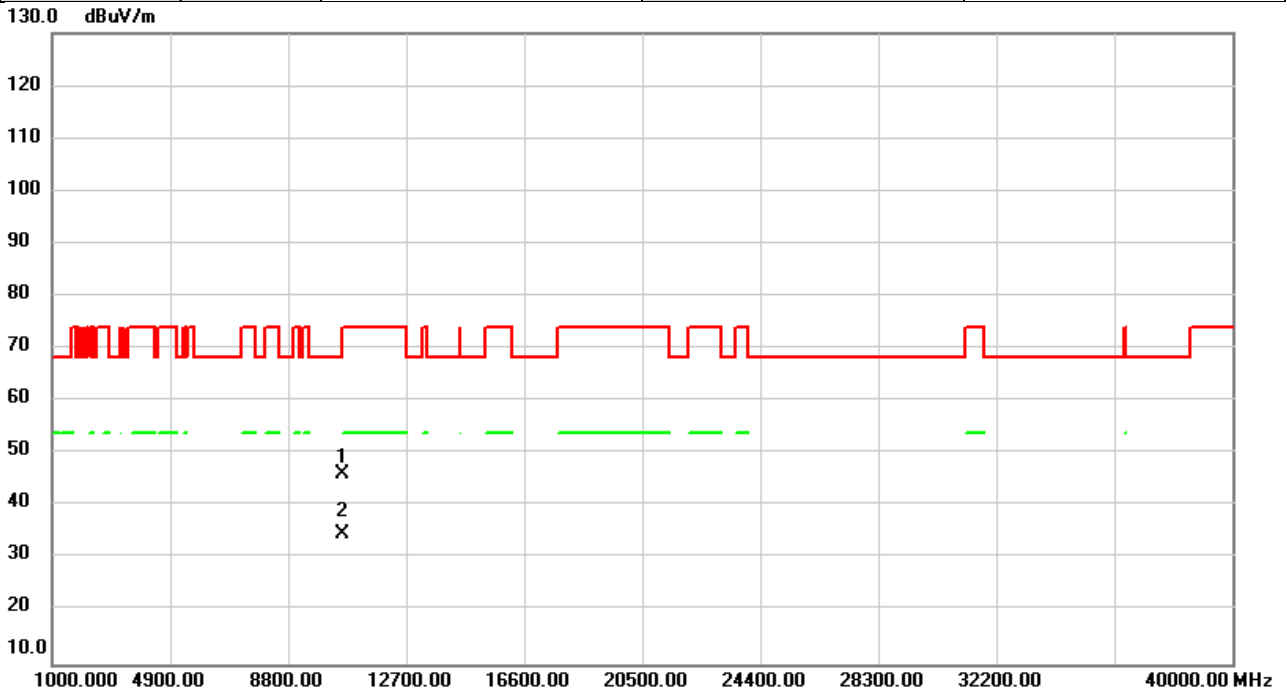

No.	Mk.	Freq.	Reading Level	Correct Factor	Measurement	Limit	Over	Detector	Comment
		MHz	dBuV	dB	dBuV/m	dBuV/m	dB		
1		10600.00	44.96	1.09	46.05	68.20	-22.15	peak	
2	*	10600.00	33.81	1.09	34.90	54.00	-19.10	AVG	

REMARKS:

- (1) Measurement Value = Reading Level + Correct Factor.
- (2) Margin Level = Measurement Value - Limit Value.

Test Mode	IEEE 802.11ac (VHT20)	Test Date	2022/9/14
Test Frequency	5300MHz	Polarization	Horizontal
Temp	25°C	Hum.	62%

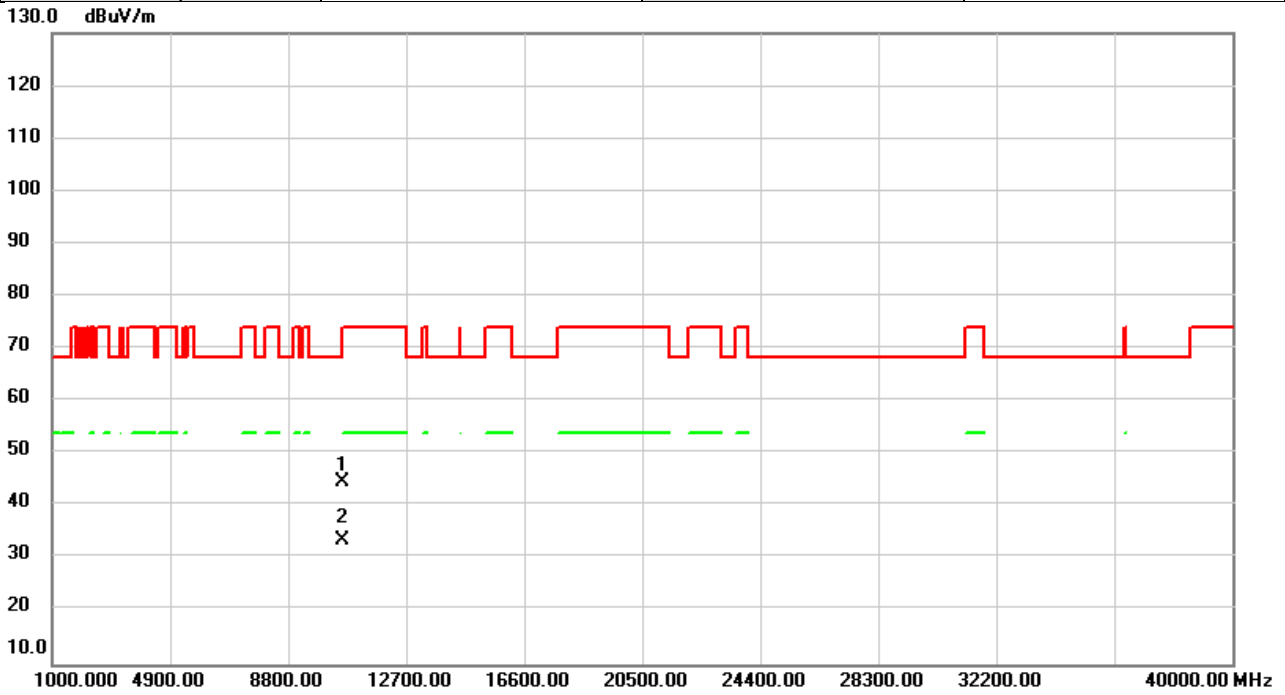

No.	Mk.	Freq. MHz	Reading Level dBuV	Correct Factor dB	Measure- ment dBuV/m	Limit dBuV/m	Over dB	Detector	Comment
1		10600.00	43.49	1.09	44.58	68.20	-23.62	peak	
2	*	10600.00	32.54	1.09	33.63	54.00	-20.37	AVG	

REMARKS:

- (1) Measurement Value = Reading Level + Correct Factor.
- (2) Margin Level = Measurement Value - Limit Value.

Test Mode	IEEE 802.11ac (VHT20)	Test Date	2022/9/14
Test Frequency	5320MHz	Polarization	Vertical
Temp	25°C	Hum.	62%

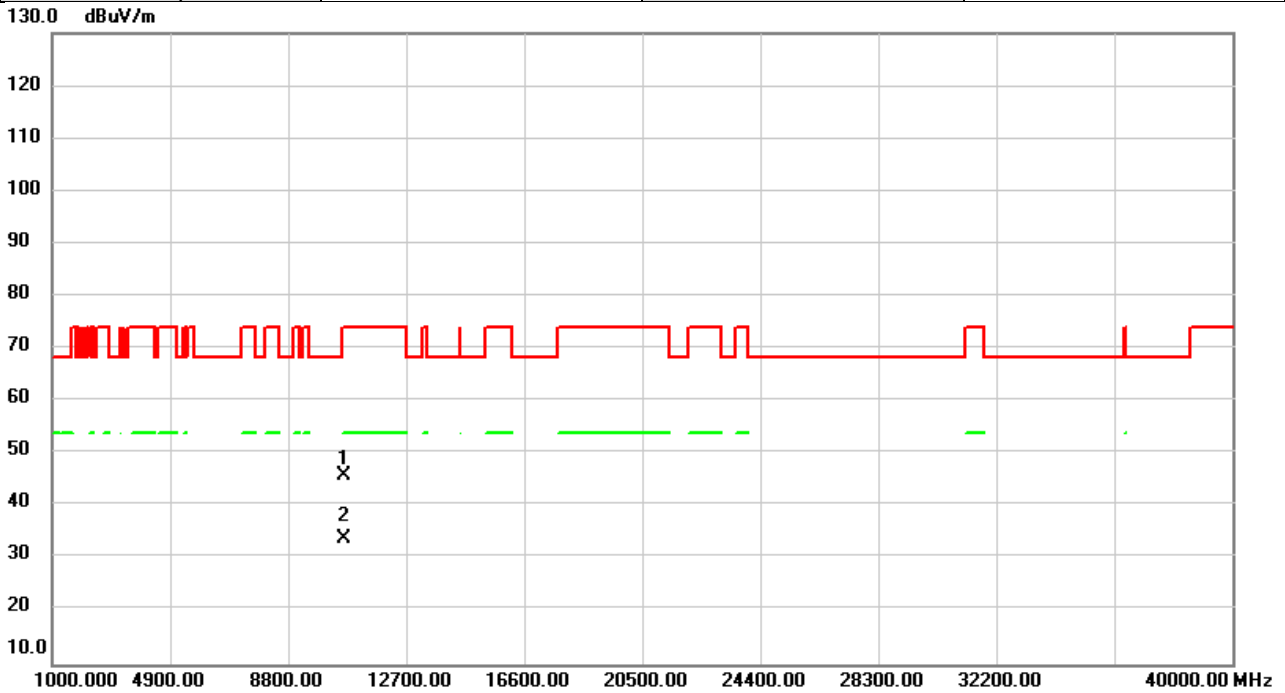

No.	Mk.	Freq. MHz	Reading Level dBuV	Correct Factor dB	Measure- ment dBuV/m	Limit dBuV/m	Over dB	Detector	Comment
1		10640.00	44.70	1.10	45.80	74.00	-28.20	peak	
2	*	10640.00	32.61	1.10	33.71	54.00	-20.29	AVG	

REMARKS:

- (1) Measurement Value = Reading Level + Correct Factor.
- (2) Margin Level = Measurement Value - Limit Value.

Test Mode	IEEE 802.11ac (VHT20)	Test Date	2022/9/14
Test Frequency	5320MHz	Polarization	Horizontal
Temp	25°C	Hum.	62%

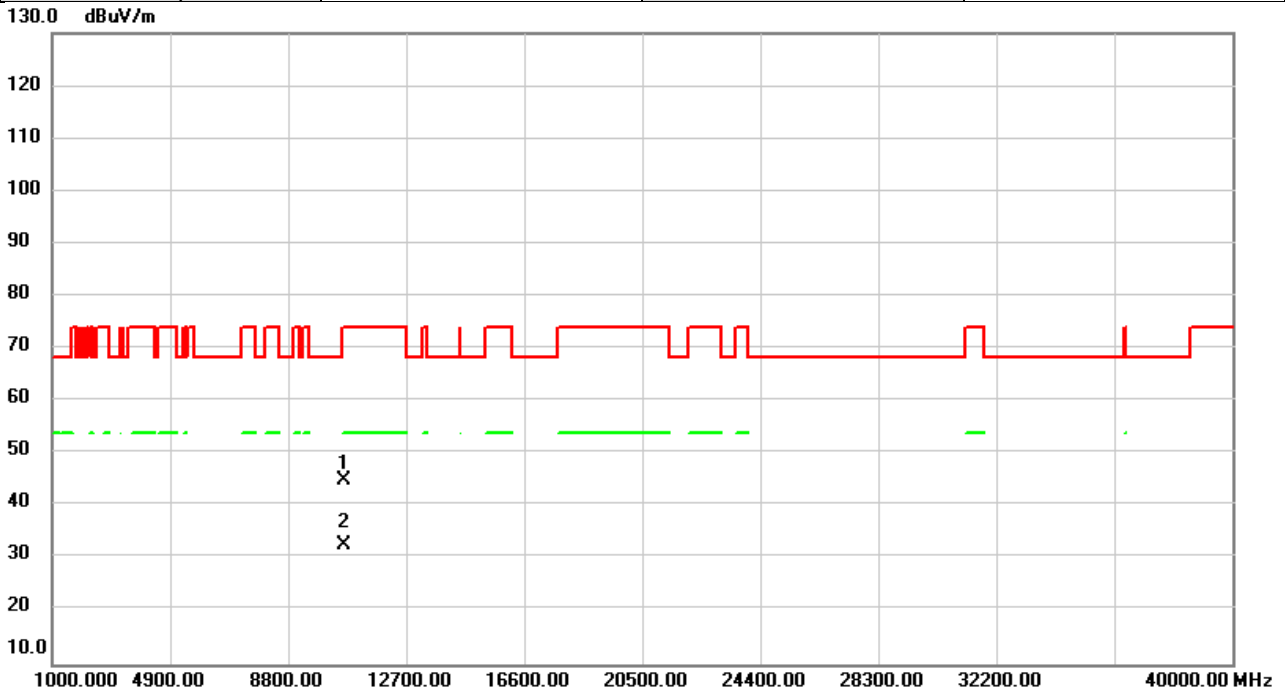

No.	Mk.	Freq. MHz	Reading Level dBuV	Correct Factor dB	Measure- ment dBuV/m	Limit dBuV/m	Over dB	Detector	Comment
1		10640.00	43.90	1.10	45.00	74.00	-29.00	peak	
2	*	10640.00	31.57	1.10	32.67	54.00	-21.33	AVG	

REMARKS:

- (1) Measurement Value = Reading Level + Correct Factor.
- (2) Margin Level = Measurement Value - Limit Value.

Test Mode	IEEE 802.11ac (VHT20)	Test Date	2022/9/14
Test Frequency	5500MHz	Polarization	Vertical
Temp	25°C	Hum.	62%

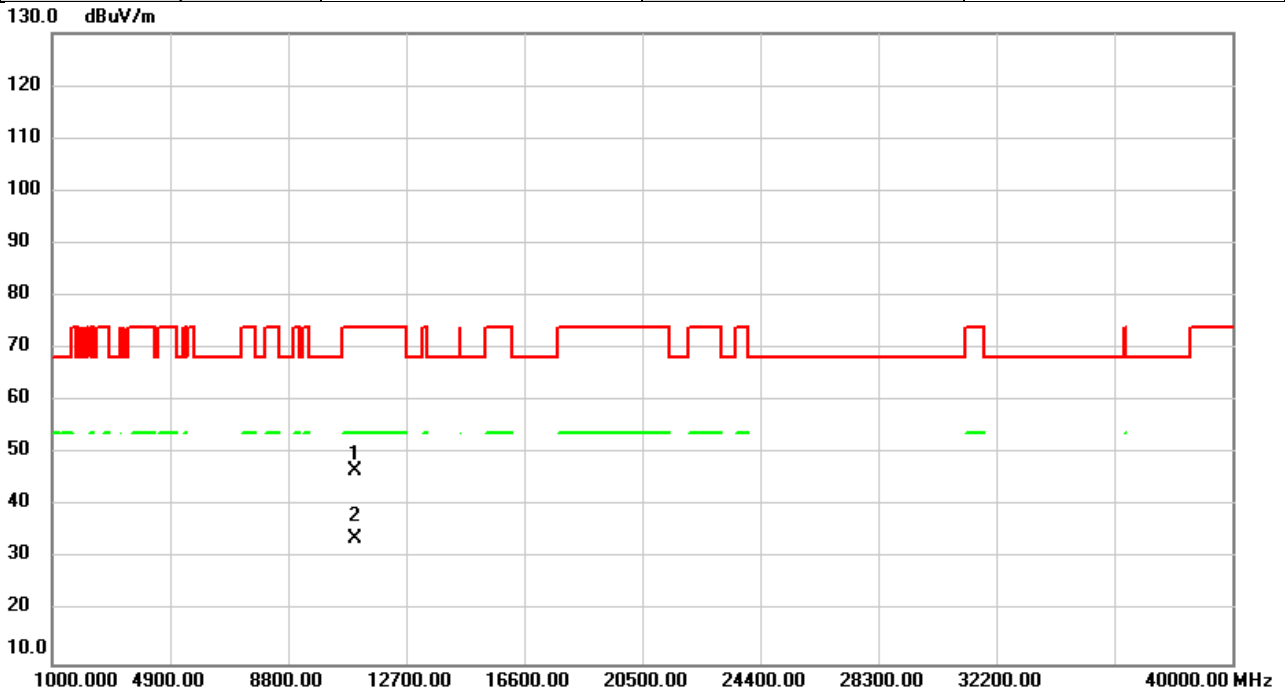

No.	Mk.	Freq. MHz	Reading Level dBuV	Correct Factor dB	Measure- ment dBuV/m	Limit dBuV/m	Over dB	Detector	Comment
1		11000.00	45.53	1.21	46.74	74.00	-27.26	peak	
2	*	11000.00	32.56	1.21	33.77	54.00	-20.23	AVG	

REMARKS:

- (1) Measurement Value = Reading Level + Correct Factor.
- (2) Margin Level = Measurement Value - Limit Value.

Test Mode	IEEE 802.11ac (VHT20)	Test Date	2022/9/14
Test Frequency	5500MHz	Polarization	Horizontal
Temp	25°C	Hum.	62%

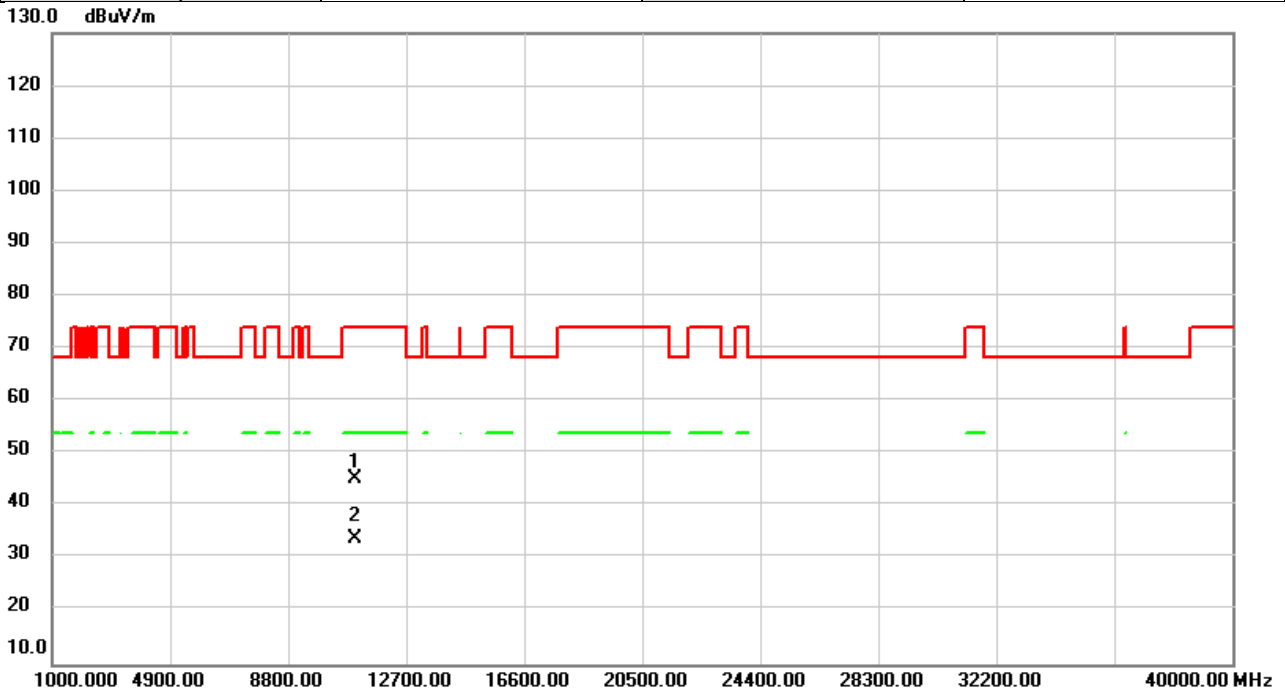

No.	Mk.	Freq.	Reading Level	Correct Factor	Measurement	Limit	Over	Detector	Comment
		MHz	dBuV	dB	dBuV/m	dBuV/m	dB		
1		11000.00	44.00	1.21	45.21	74.00	-28.79	peak	
2	*	11000.00	32.50	1.21	33.71	54.00	-20.29	AVG	

REMARKS:

- (1) Measurement Value = Reading Level + Correct Factor.
- (2) Margin Level = Measurement Value - Limit Value.

Test Mode	IEEE 802.11ac (VHT20)	Test Date	2022/9/14
Test Frequency	5580MHz	Polarization	Vertical
Temp	25°C	Hum.	62%

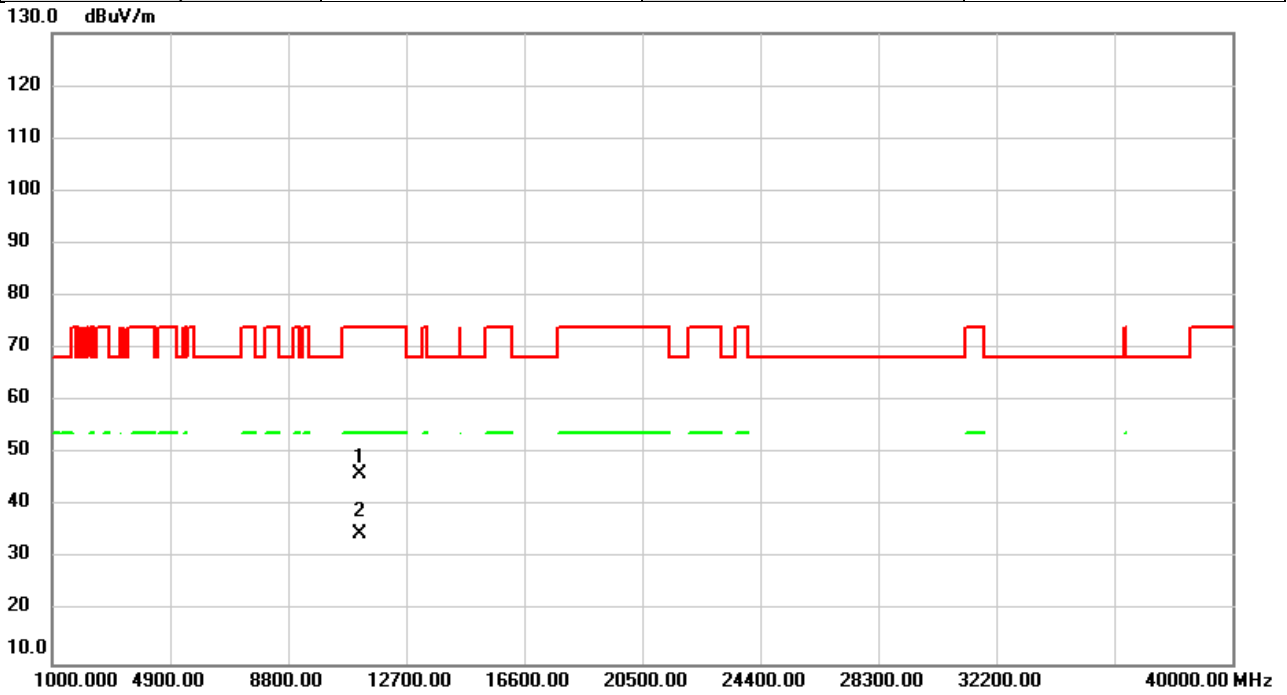

No.	Mk.	Freq. MHz	Reading Level dBuV	Correct Factor dB	Measure- ment dBuV/m	Limit dBuV/m	Over dB	Detector	Comment
1		11160.00	44.39	1.68	46.07	74.00	-27.93	peak	
2	*	11160.00	33.14	1.68	34.82	54.00	-19.18	AVG	

REMARKS:

- (1) Measurement Value = Reading Level + Correct Factor.
- (2) Margin Level = Measurement Value - Limit Value.

Test Mode	IEEE 802.11ac (VHT20)	Test Date	2022/9/14
Test Frequency	5580MHz	Polarization	Horizontal
Temp	25°C	Hum.	62%

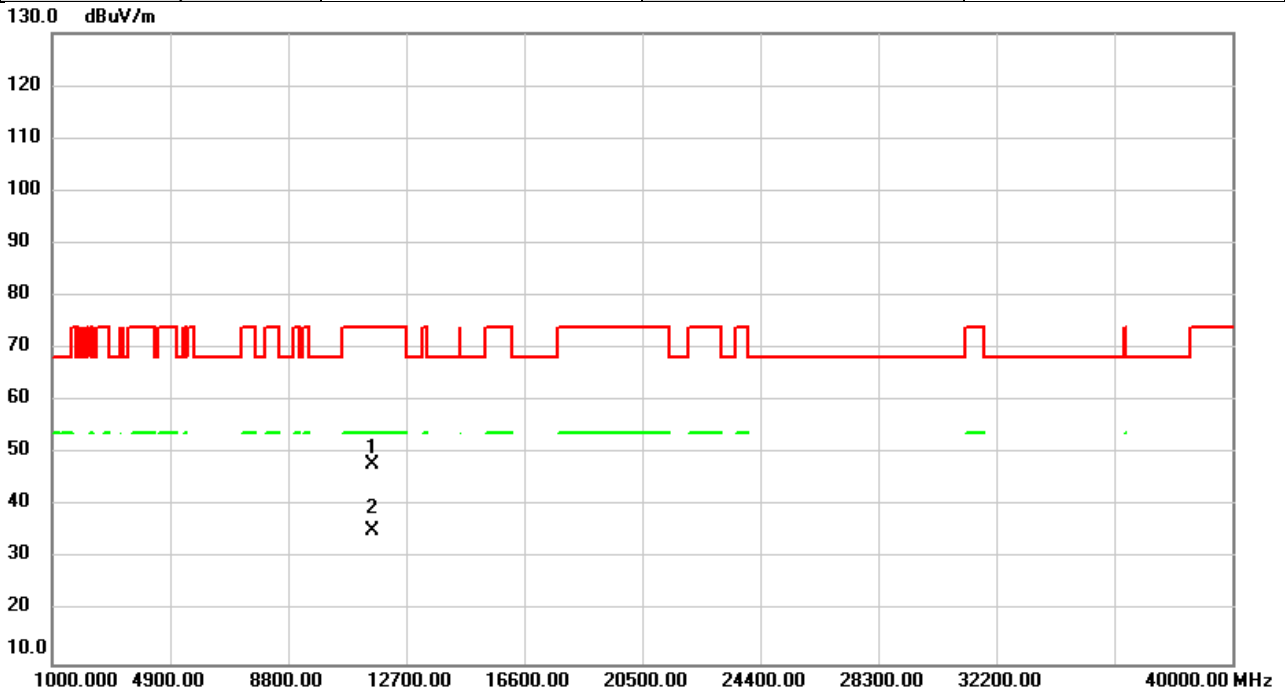

No.	Mk.	Freq.	Reading Level	Correct Factor	Measurement	Limit	Over	Detector	Comment
		MHz	dBuV	dB	dBuV/m	dBuV/m	dB		
1		11600.00	45.16	2.84	48.00	74.00	-26.00	peak	
2	*	11600.00	32.63	2.84	35.47	54.00	-18.53	AVG	

REMARKS:

- (1) Measurement Value = Reading Level + Correct Factor.
- (2) Margin Level = Measurement Value - Limit Value.

Test Mode	IEEE 802.11ac (VHT20)	Test Date	2022/9/14
Test Frequency	5700MHz	Polarization	Vertical
Temp	25°C	Hum.	62%

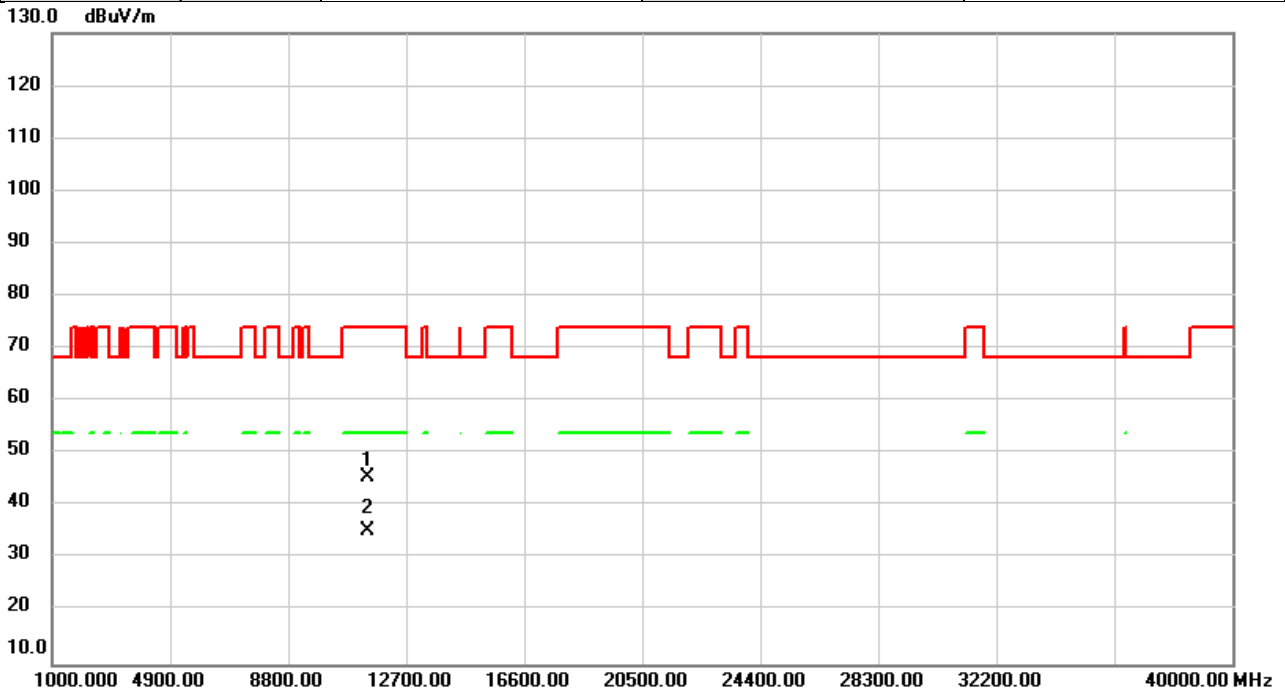

No.	Mk.	Freq. MHz	Reading Level dBuV	Correct Factor dB	Measure- ment dBuV/m	Limit dBuV/m	Over dB	Detector	Comment
1		11400.00	43.28	2.36	45.64	74.00	-28.36	peak	
2	*	11400.00	33.03	2.36	35.39	54.00	-18.61	AVG	

REMARKS:

- (1) Measurement Value = Reading Level + Correct Factor.
- (2) Margin Level = Measurement Value - Limit Value.

Test Mode	IEEE 802.11ac (VHT20)	Test Date	2022/9/14
Test Frequency	5700MHz	Polarization	Horizontal
Temp	25°C	Hum.	62%

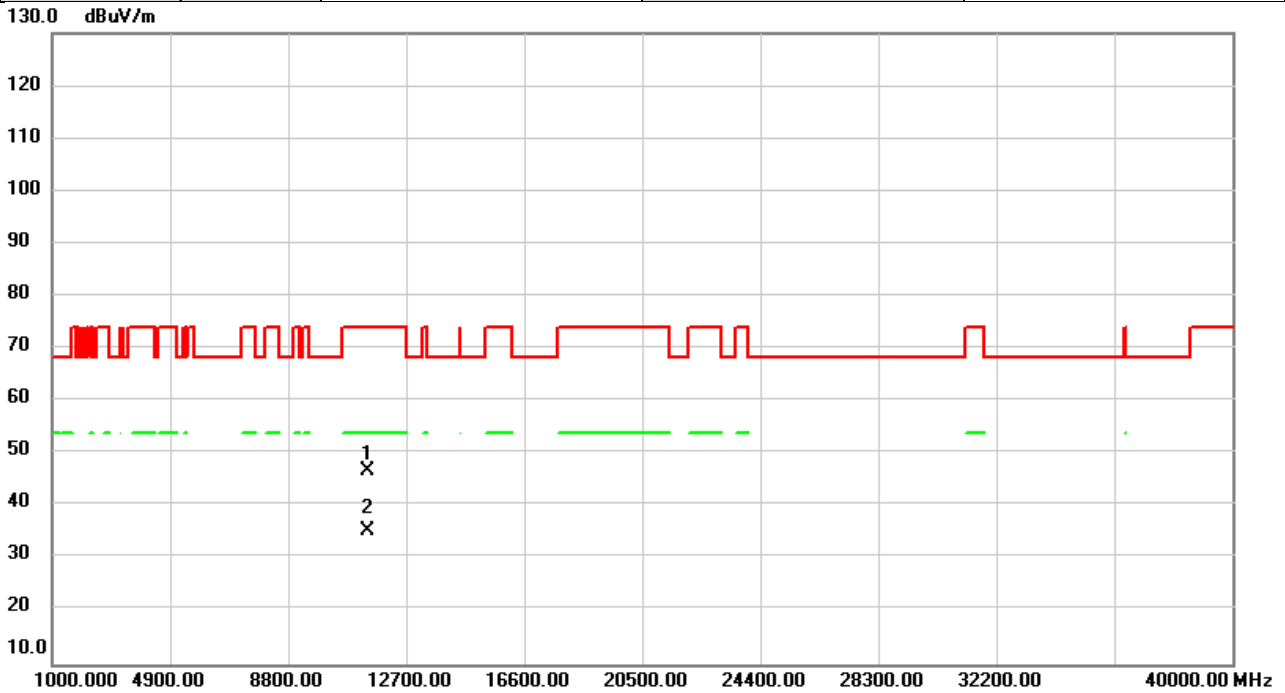

No.	Mk.	Freq. MHz	Reading Level dBuV	Correct Factor dB	Measure- ment dBuV/m	Limit dBuV/m	Over dB	Detector	Comment
1		11400.00	44.47	2.36	46.83	74.00	-27.17	peak	
2	*	11400.00	33.09	2.36	35.45	54.00	-18.55	AVG	

REMARKS:

- (1) Measurement Value = Reading Level + Correct Factor.
- (2) Margin Level = Measurement Value - Limit Value.

Test Mode	IEEE 802.11ac (VHT20)	Test Date	2022/9/14
Test Frequency	5720MHz	Polarization	Vertical
Temp	25°C	Hum.	62%

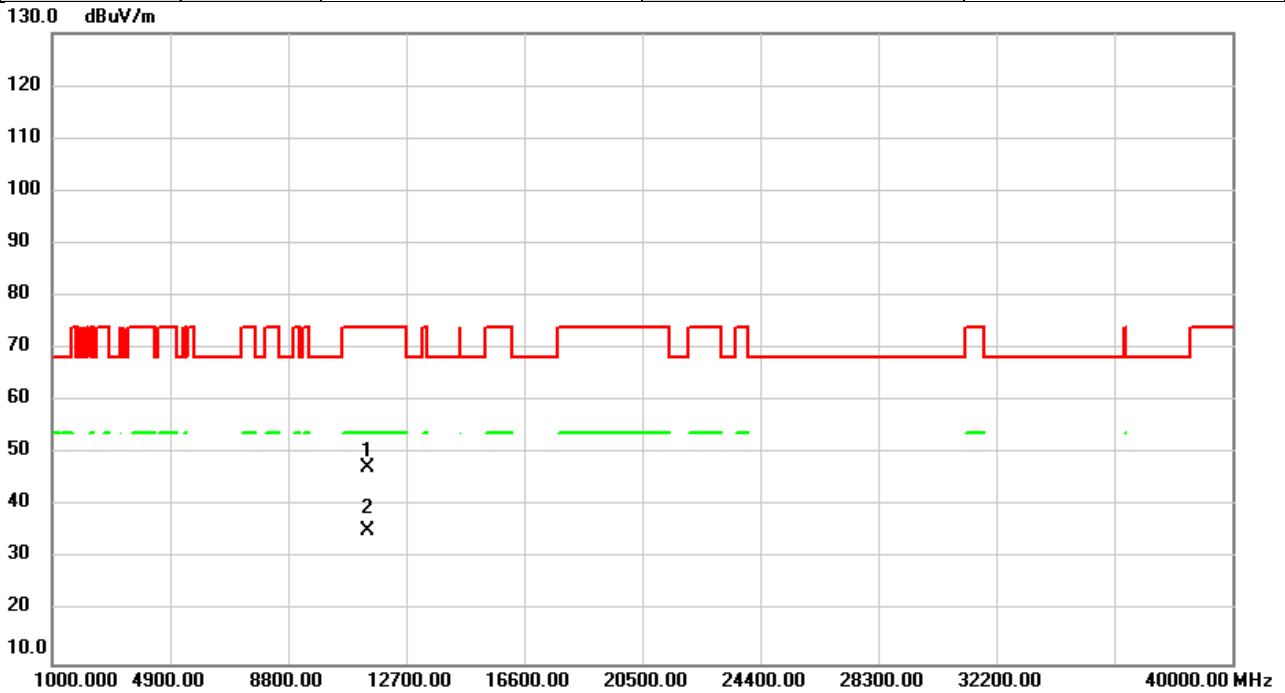

No.	Mk.	Freq. MHz	Reading Level dBuV	Correct Factor dB	Measure- ment dBuV/m	Limit dBuV/m	Over dB	Detector	Comment
1		11440.00	45.02	2.47	47.49	74.00	-26.51	peak	
2	*	11440.00	32.88	2.47	35.35	54.00	-18.65	AVG	

REMARKS:

- (1) Measurement Value = Reading Level + Correct Factor.
- (2) Margin Level = Measurement Value - Limit Value.

Test Mode	IEEE 802.11ac (VHT20)	Test Date	2022/9/14
Test Frequency	5720MHz	Polarization	Horizontal
Temp	25°C	Hum.	62%

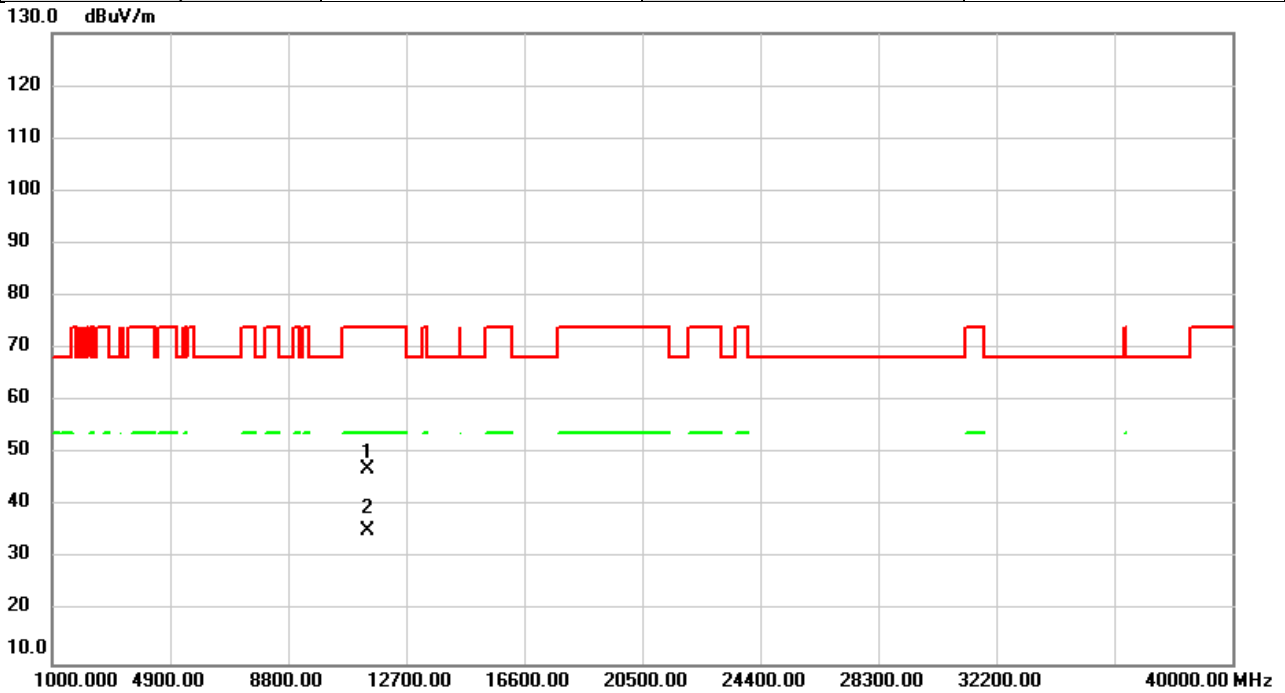

No.	Mk.	Freq. MHz	Reading Level dBuV	Correct Factor dB	Measure- ment dBuV/m	Limit dBuV/m	Over dB	Detector	Comment
1		11440.00	44.54	2.47	47.01	74.00	-26.99	peak	
2	*	11440.00	32.78	2.47	35.25	54.00	-18.75	AVG	

REMARKS:

- (1) Measurement Value = Reading Level + Correct Factor.
- (2) Margin Level = Measurement Value - Limit Value.

Test Mode	IEEE 802.11ac (VHT40)	Test Date	2022/9/14
Test Frequency	5190MHz	Polarization	Vertical
Temp	25°C	Hum.	62%

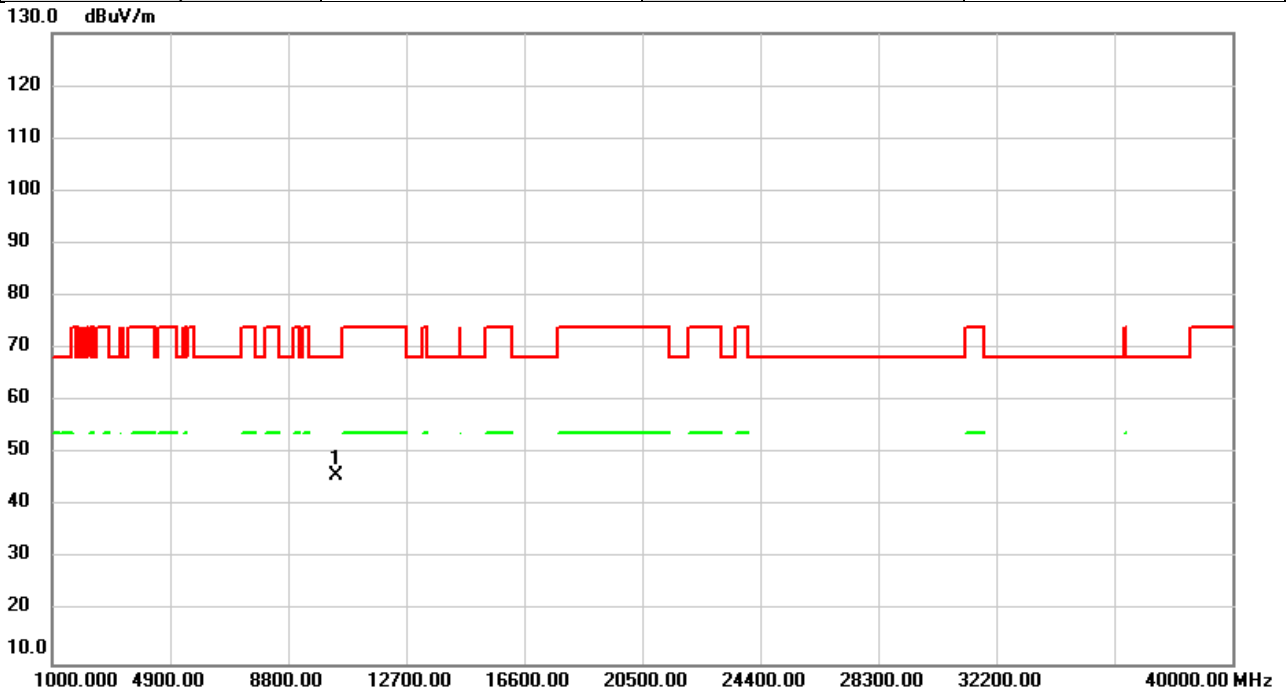

No.	Mk.	Freq.	Reading Level	Correct Factor	Measurement	Limit	Over	Detector	Comment
		MHz	dBuV	dB	dBuV/m	dBuV/m	dB		
1	*	10380.00	44.72	1.04	45.76	68.20	-22.44	peak	

REMARKS:

- (1) Measurement Value = Reading Level + Correct Factor.
- (2) Margin Level = Measurement Value - Limit Value.

Test Mode	IEEE 802.11ac (VHT40)	Test Date	2022/9/14
Test Frequency	5190MHz	Polarization	Horizontal
Temp	25°C	Hum.	62%

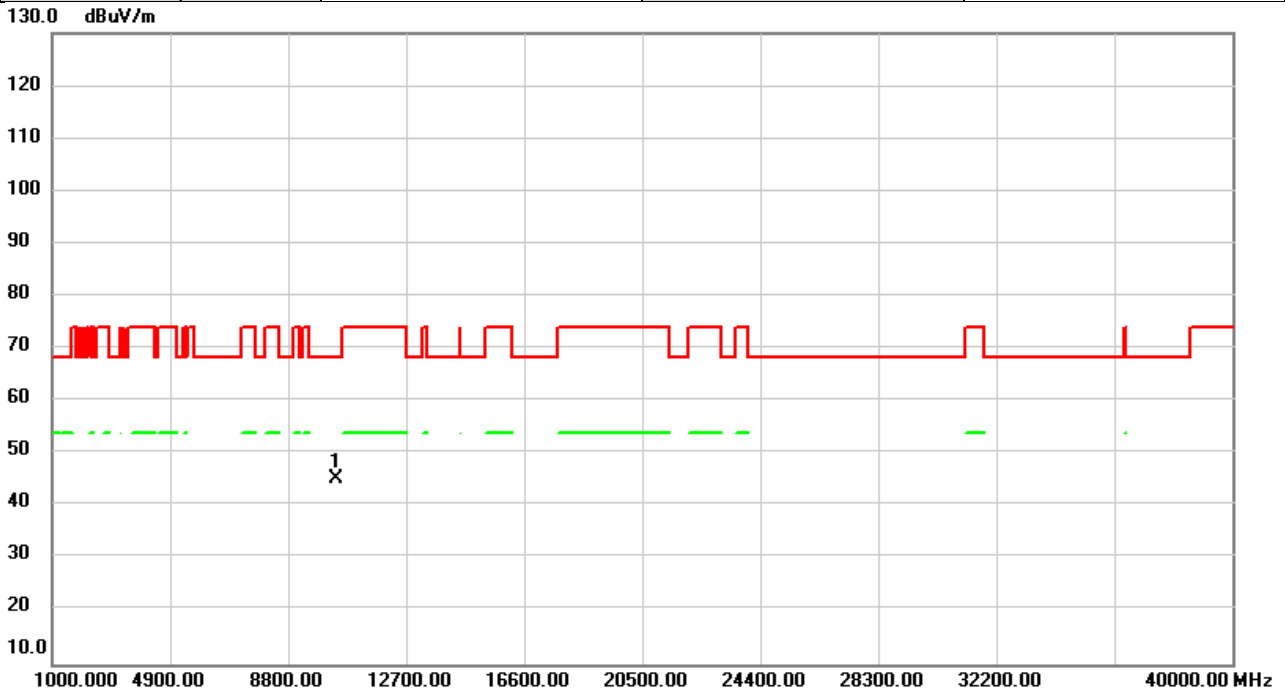

No.	Mk.	Freq. MHz	Reading Level dBuV	Correct Factor dB	Measure- ment dBuV/m	Limit dBuV/m	Over dB	Detector	Comment
1	*	10380.00	44.19	1.04	45.23	68.20	-22.97	peak	

REMARKS:

- (1) Measurement Value = Reading Level + Correct Factor.
- (2) Margin Level = Measurement Value - Limit Value.

Test Mode	IEEE 802.11ac (VHT40)	Test Date	2022/9/14
Test Frequency	5230MHz	Polarization	Vertical
Temp	25°C	Hum.	62%

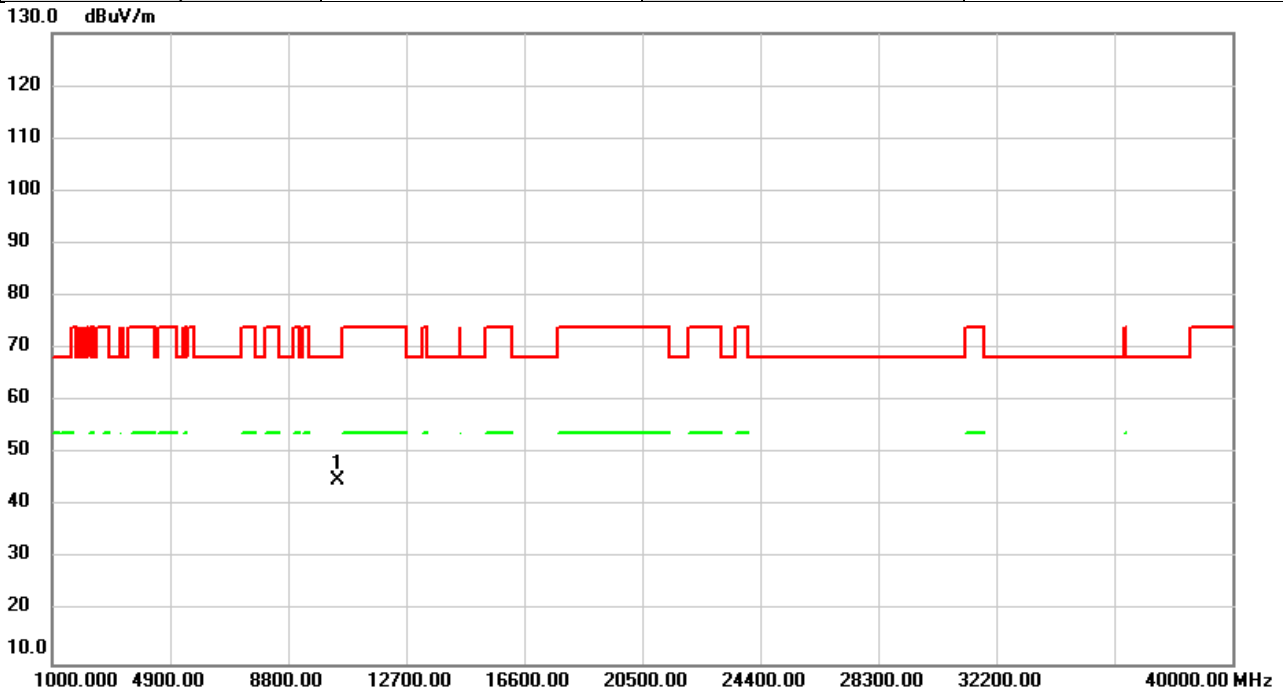

No.	Mk.	Freq.	Reading Level	Correct Factor	Measurement	Limit	Over	Detector	Comment
		MHz	dBuV	dB	dBuV/m	dBuV/m	dB		
1	*	10460.00	43.82	1.05	44.87	68.20	-23.33	peak	

REMARKS:

- (1) Measurement Value = Reading Level + Correct Factor.
- (2) Margin Level = Measurement Value - Limit Value.

Test Mode	IEEE 802.11ac (VHT40)	Test Date	2022/9/14
Test Frequency	5230MHz	Polarization	Horizontal
Temp	25°C	Hum.	62%

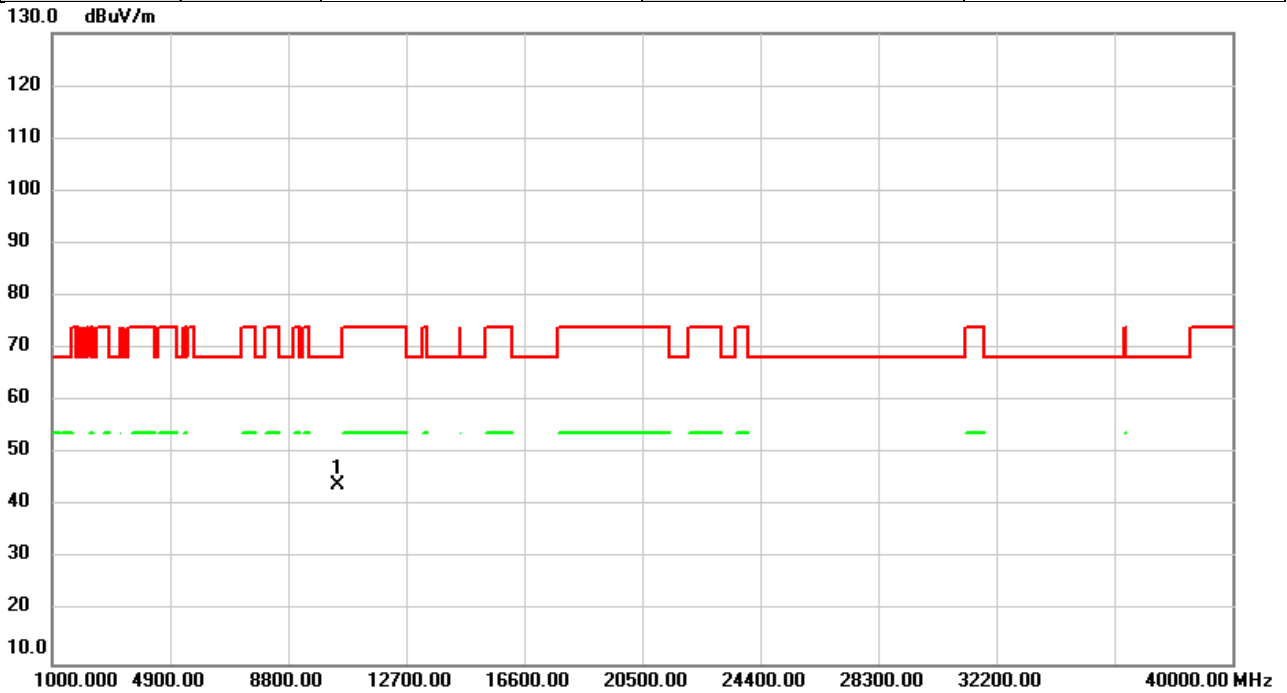

No.	Mk.	Freq.	Reading Level	Correct Factor	Measurement	Limit	Over	Detector	Comment
		MHz	dBuV	dB	dBuV/m	dBuV/m	dB		
1	*	10460.00	43.12	1.05	44.17	68.20	-24.03	peak	

REMARKS:

- (1) Measurement Value = Reading Level + Correct Factor.
- (2) Margin Level = Measurement Value - Limit Value.

Test Mode	IEEE 802.11ac (VHT40)	Test Date	2022/9/14
Test Frequency	5270MHz	Polarization	Vertical
Temp	25°C	Hum.	62%

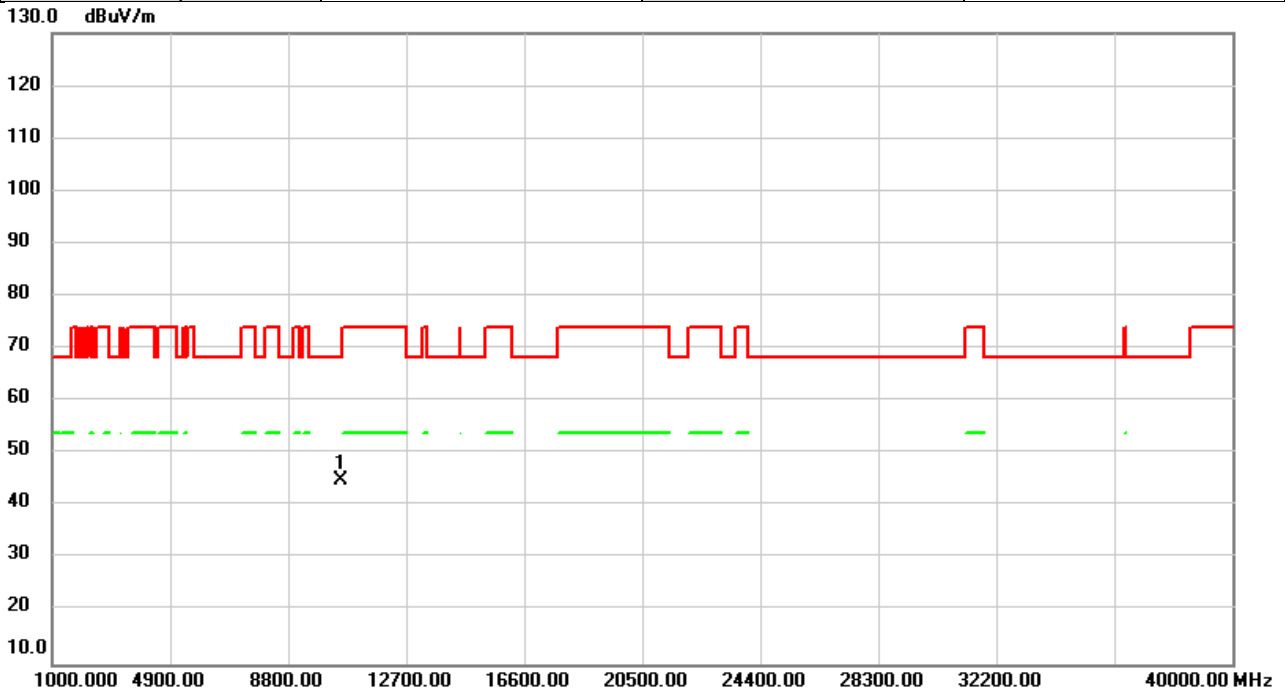

No.	Mk.	Freq.	Reading Level	Correct Factor	Measurement	Limit	Over	Detector	Comment
		MHz	dBuV	dB	dBuV/m	dBuV/m	dB		
1	*	10540.00	43.86	1.08	44.94	68.20	-23.26	peak	

REMARKS:

- (1) Measurement Value = Reading Level + Correct Factor.
- (2) Margin Level = Measurement Value - Limit Value.

Test Mode	IEEE 802.11ac (VHT40)	Test Date	2022/9/14
Test Frequency	5270MHz	Polarization	Horizontal
Temp	25°C	Hum.	62%

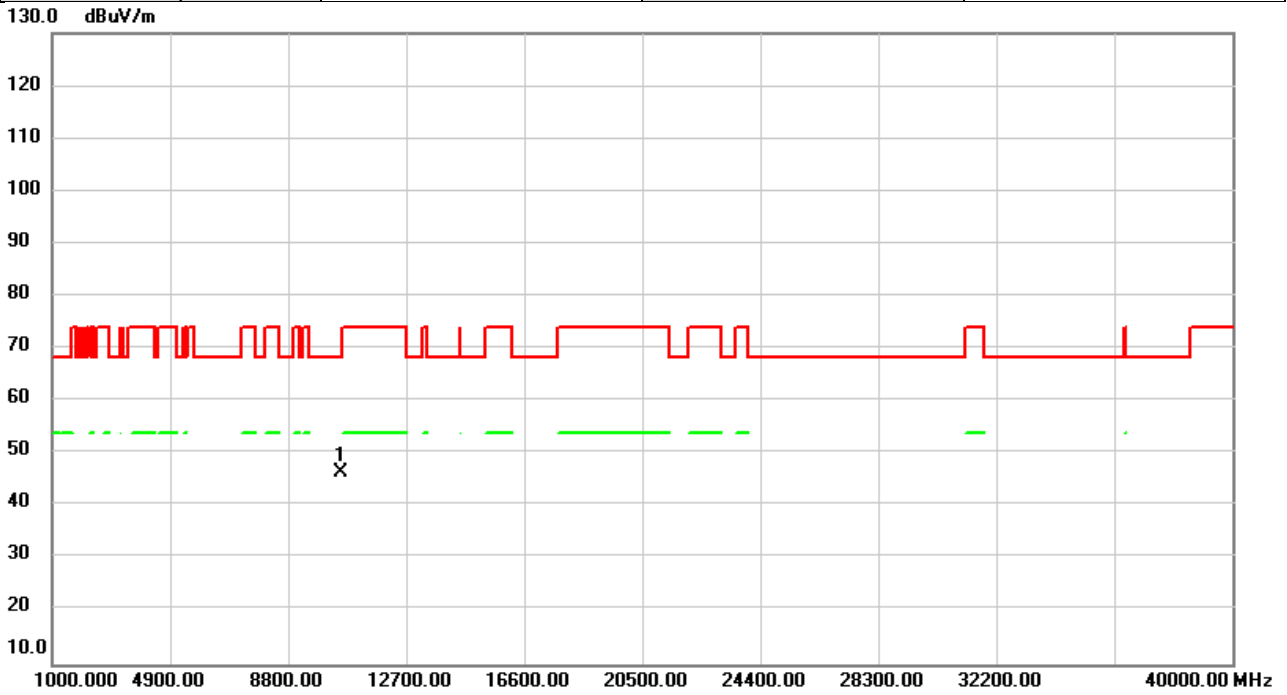

No.	Mk.	Freq.	Reading Level	Correct Factor	Measurement	Limit	Over	Detector	Comment
		MHz	dBuV	dB	dBuV/m	dBuV/m	dB		
1	*	10540.00	45.42	1.08	46.50	68.20	-21.70	peak	

REMARKS:

- (1) Measurement Value = Reading Level + Correct Factor.
- (2) Margin Level = Measurement Value - Limit Value.

Test Mode	IEEE 802.11ac (VHT40)	Test Date	2022/9/14
Test Frequency	5310MHz	Polarization	Vertical
Temp	25°C	Hum.	62%

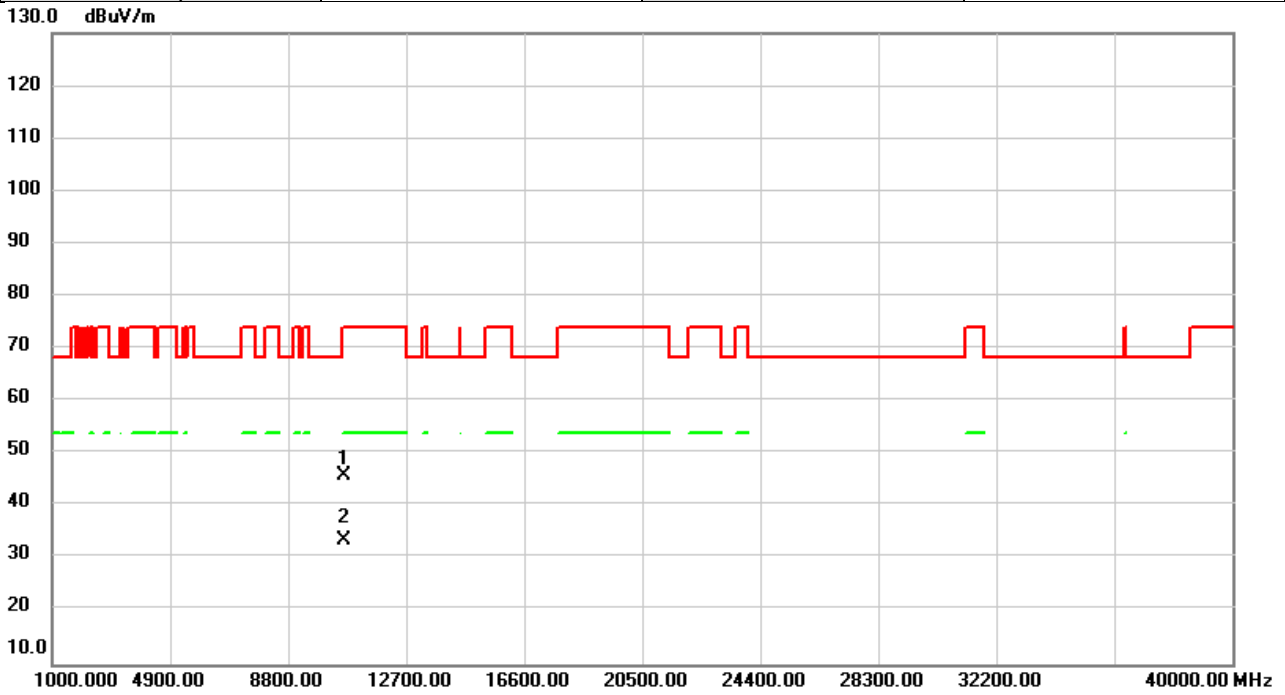

No.	Mk.	Freq. MHz	Reading Level dBuV	Correct Factor dB	Measure- ment dBuV/m	Limit dBuV/m	Over dB	Detector	Comment
1		10620.00	44.87	1.10	45.97	74.00	-28.03	peak	
2	*	10620.00	32.56	1.10	33.66	54.00	-20.34	AVG	

REMARKS:

- (1) Measurement Value = Reading Level + Correct Factor.
- (2) Margin Level = Measurement Value - Limit Value.

Test Mode	IEEE 802.11ac (VHT40)	Test Date	2022/9/14
Test Frequency	5310MHz	Polarization	Horizontal
Temp	25°C	Hum.	62%

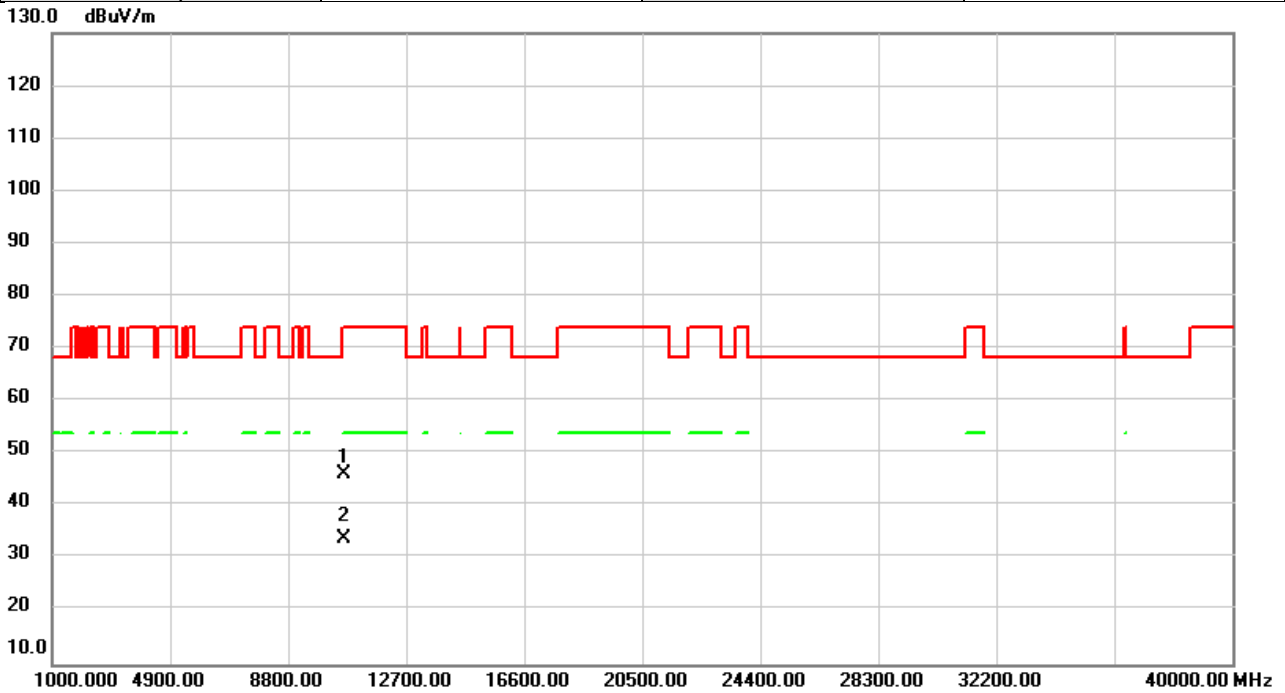

No.	Mk.	Freq. MHz	Reading Level dBuV	Correct Factor dB	Measure- ment dBuV/m	Limit dBuV/m	Over dB	Detector	Comment
1		10620.00	44.92	1.10	46.02	74.00	-27.98	peak	
2	*	10620.00	32.77	1.10	33.87	54.00	-20.13	AVG	

REMARKS:

- (1) Measurement Value = Reading Level + Correct Factor.
- (2) Margin Level = Measurement Value - Limit Value.

Test Mode	IEEE 802.11ac (VHT40)	Test Date	2022/9/14
Test Frequency	5510MHz	Polarization	Vertical
Temp	25°C	Hum.	62%

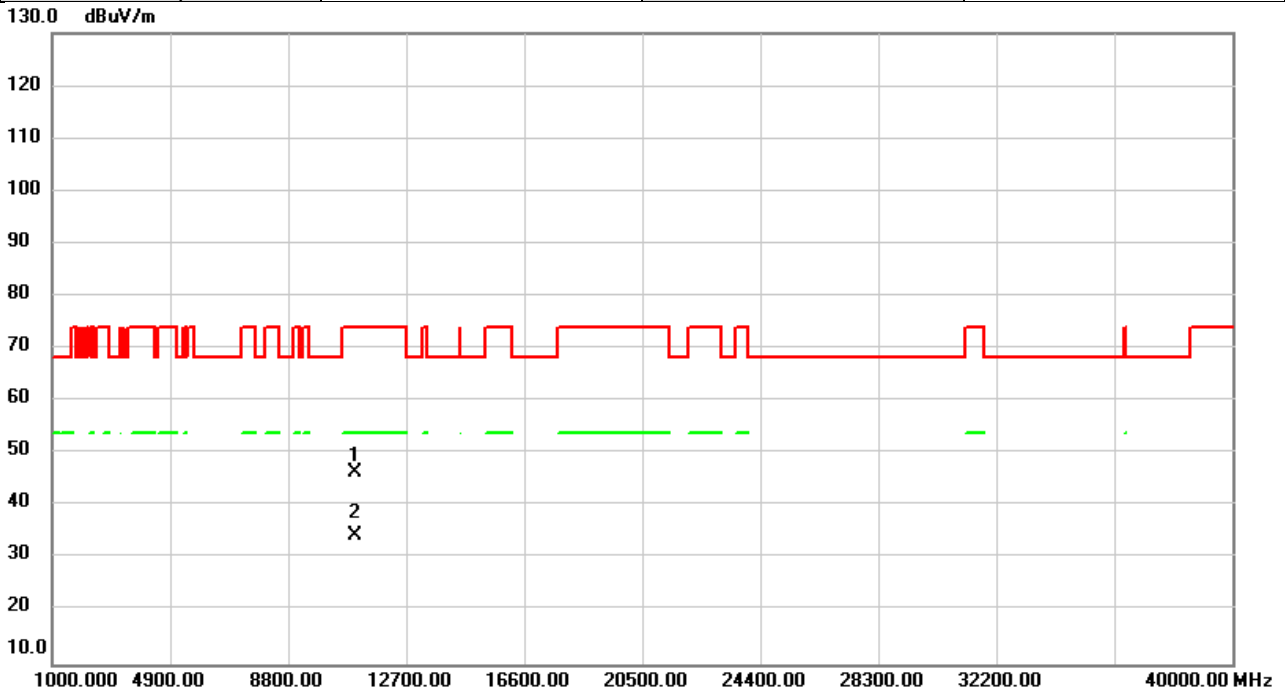

No.	Mk.	Freq. MHz	Reading Level dBuV	Correct Factor dB	Measure- ment dBuV/m	Limit dBuV/m	Over dB	Detector	Comment
1		11020.00	45.18	1.27	46.45	74.00	-27.55	peak	
2	*	11020.00	33.07	1.27	34.34	54.00	-19.66	AVG	

REMARKS:

- (1) Measurement Value = Reading Level + Correct Factor.
- (2) Margin Level = Measurement Value - Limit Value.

Test Mode	IEEE 802.11ac (VHT40)	Test Date	2022/9/14
Test Frequency	5510MHz	Polarization	Horizontal
Temp	25°C	Hum.	62%

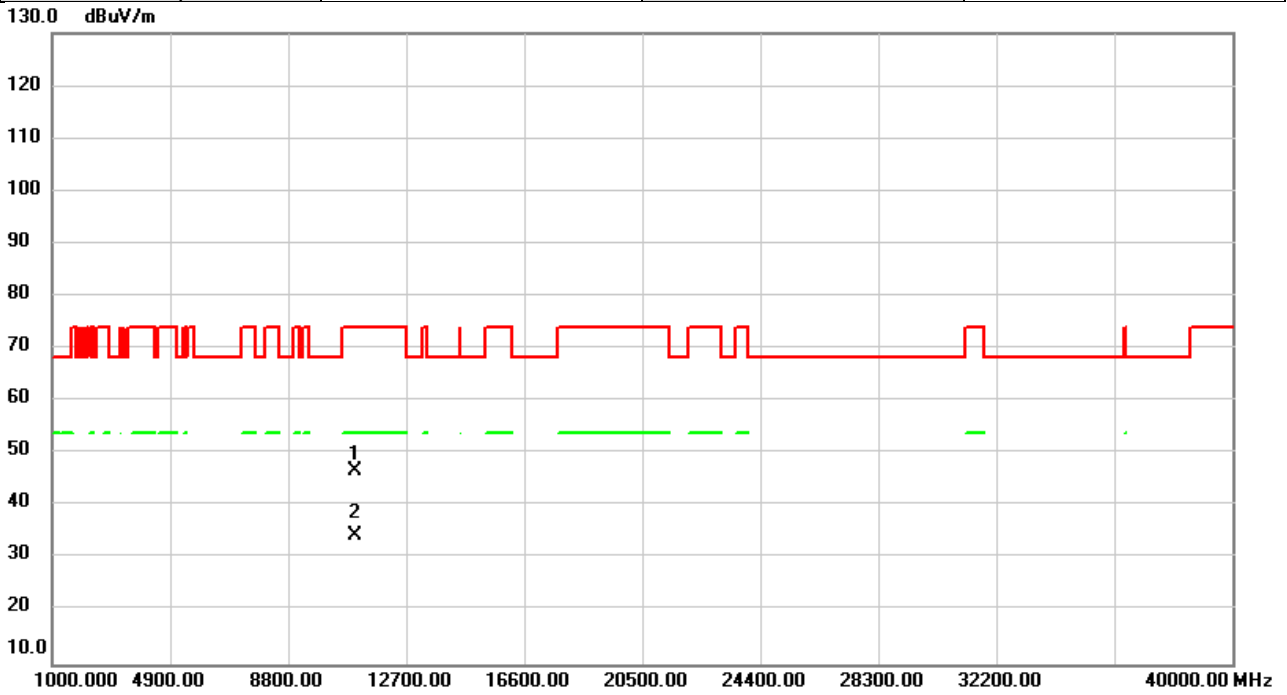

No.	Mk.	Freq. MHz	Reading Level dBuV	Correct Factor dB	Measure- ment dBuV/m	Limit dBuV/m	Over dB	Detector	Comment
1		11020.00	45.61	1.27	46.88	74.00	-27.12	peak	
2	*	11020.00	33.22	1.27	34.49	54.00	-19.51	AVG	

REMARKS:

- (1) Measurement Value = Reading Level + Correct Factor.
- (2) Margin Level = Measurement Value - Limit Value.

Test Mode	IEEE 802.11ac (VHT40)	Test Date	2022/9/14
Test Frequency	5550MHz	Polarization	Vertical
Temp	25°C	Hum.	62%

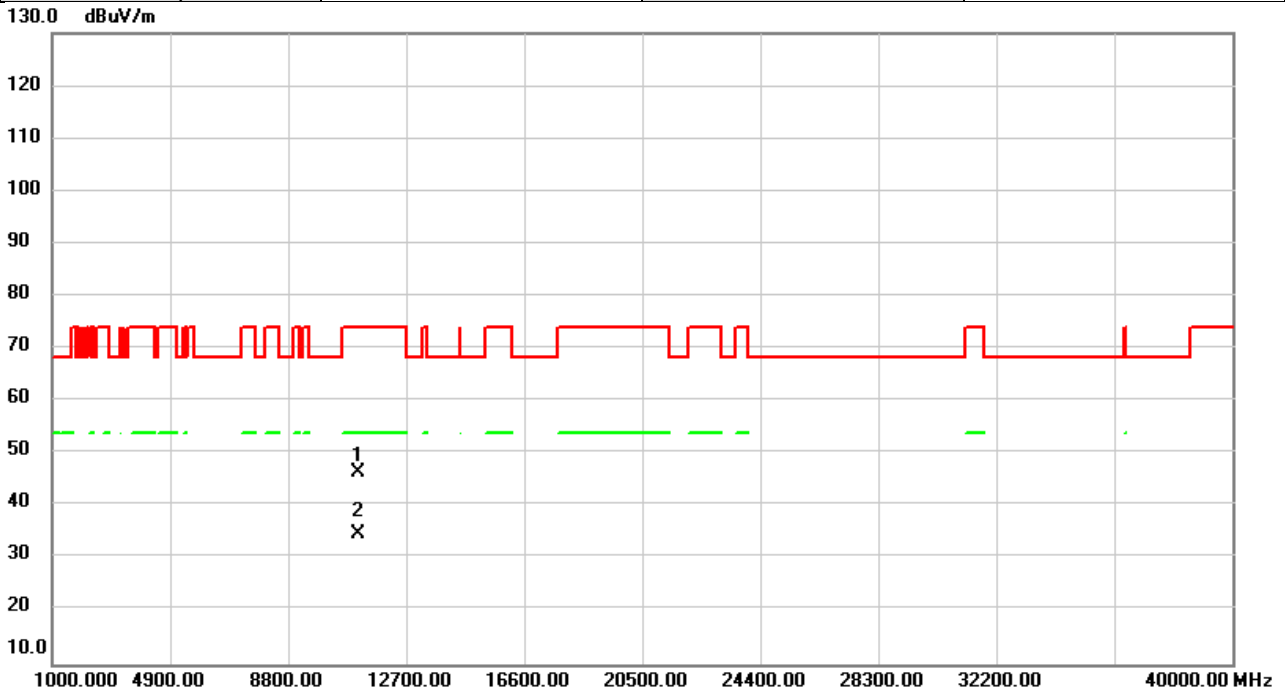

No.	Mk.	Freq. MHz	Reading Level dBuV	Correct Factor dB	Measure- ment dBuV/m	Limit dBuV/m	Over dB	Detector	Comment
1		11100.00	44.92	1.50	46.42	74.00	-27.58	peak	
2	*	11100.00	33.35	1.50	34.85	54.00	-19.15	AVG	

REMARKS:

- (1) Measurement Value = Reading Level + Correct Factor.
- (2) Margin Level = Measurement Value - Limit Value.

Test Mode	IEEE 802.11ac (VHT40)	Test Date	2022/9/14
Test Frequency	5550MHz	Polarization	Horizontal
Temp	25°C	Hum.	62%

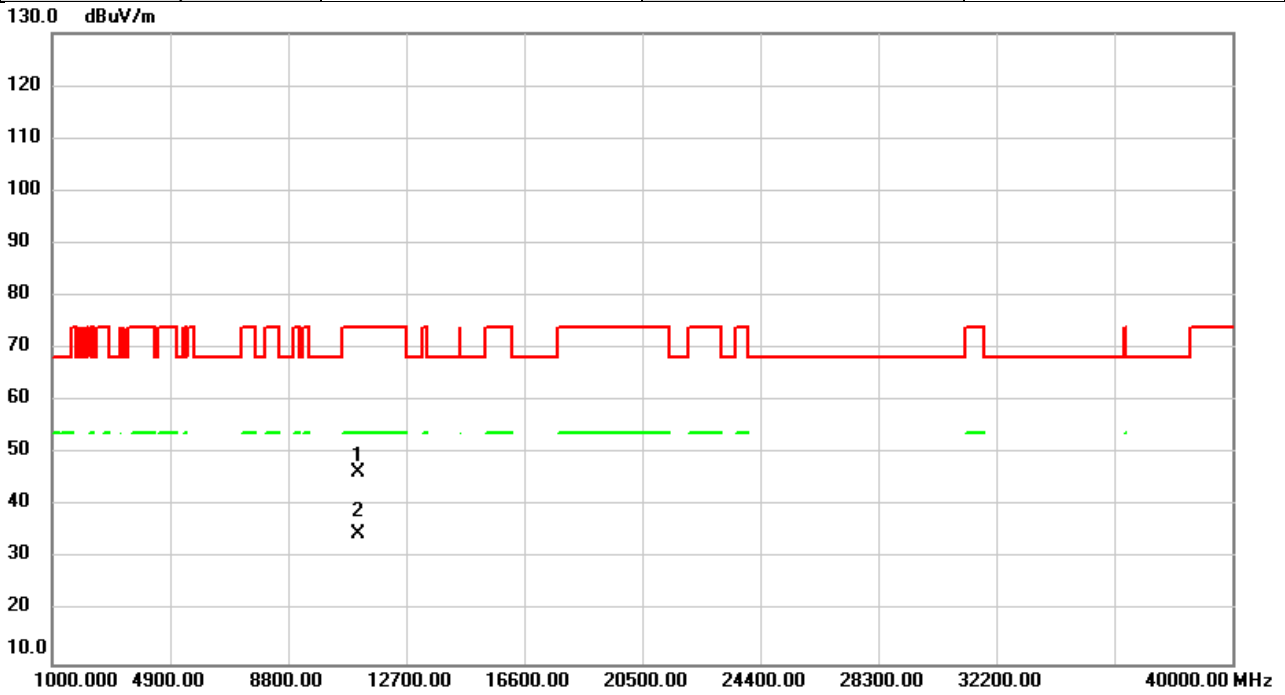

No.	Mk.	Freq. MHz	Reading Level dBuV	Correct Factor dB	Measure- ment dBuV/m	Limit dBuV/m	Over dB	Detector	Comment
1		11100.00	45.05	1.50	46.55	74.00	-27.45	peak	
2	*	11100.00	33.27	1.50	34.77	54.00	-19.23	AVG	

REMARKS:

- (1) Measurement Value = Reading Level + Correct Factor.
- (2) Margin Level = Measurement Value - Limit Value.

Test Mode	IEEE 802.11ac (VHT40)	Test Date	2022/9/14
Test Frequency	5670MHz	Polarization	Vertical
Temp	25°C	Hum.	62%

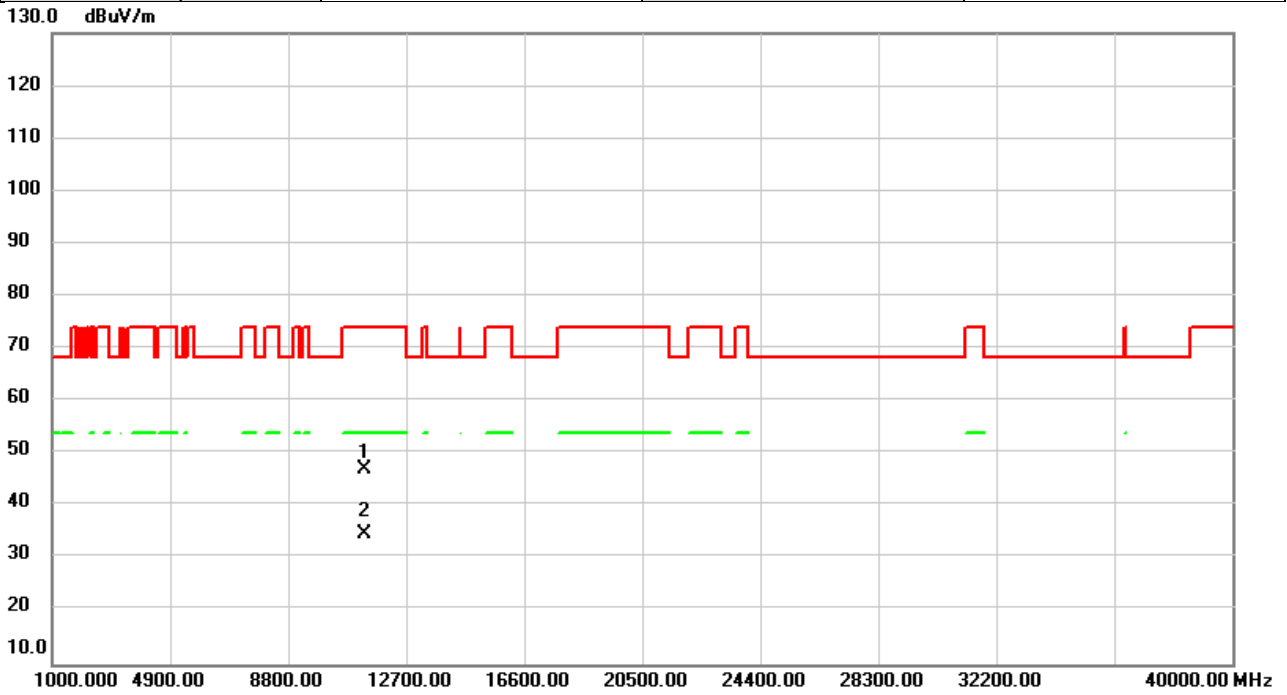

No.	Mk.	Freq. MHz	Reading Level dBuV	Correct Factor dB	Measure- ment dBuV/m	Limit dBuV/m	Over dB	Detector	Comment
1		11340.00	44.95	2.18	47.13	74.00	-26.87	peak	
2	*	11340.00	32.63	2.18	34.81	54.00	-19.19	AVG	

REMARKS:

- (1) Measurement Value = Reading Level + Correct Factor.
- (2) Margin Level = Measurement Value - Limit Value.

Test Mode	IEEE 802.11ac (VHT40)	Test Date	2022/9/14
Test Frequency	5670MHz	Polarization	Horizontal
Temp	25°C	Hum.	62%

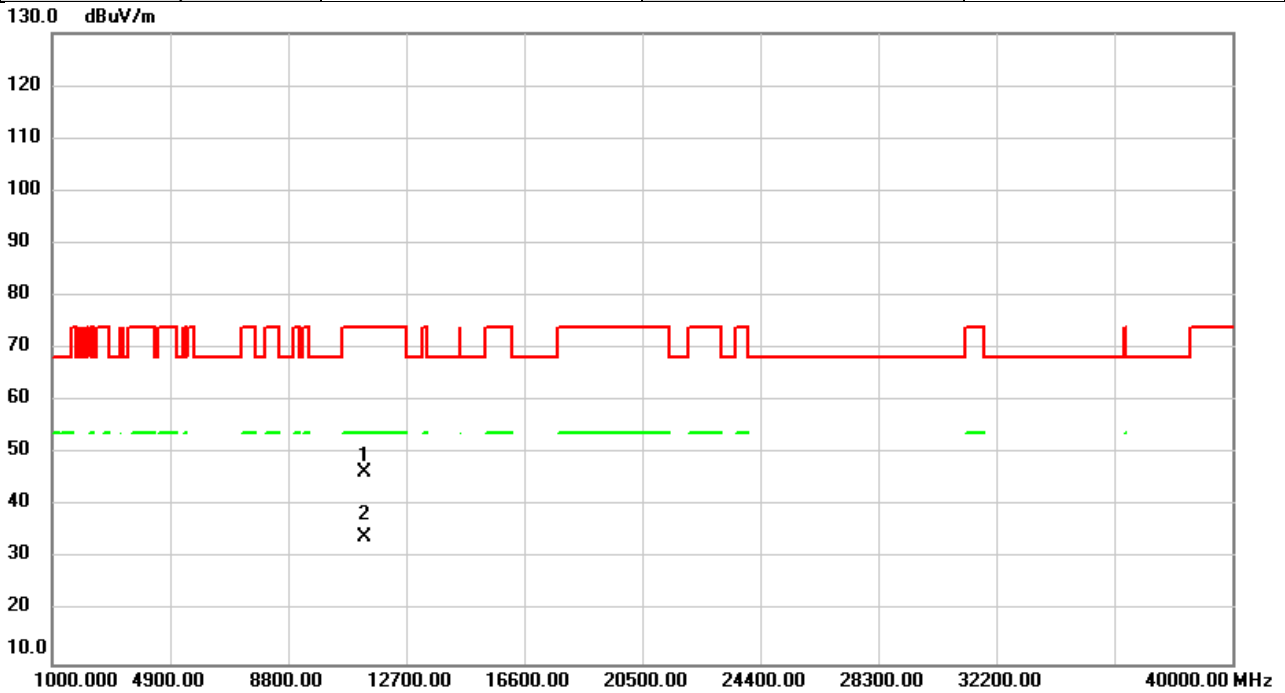

No.	Mk.	Freq. MHz	Reading Level dBuV	Correct Factor dB	Measure- ment dBuV/m	Limit dBuV/m	Over dB	Detector	Comment
1		11340.00	44.34	2.18	46.52	74.00	-27.48	peak	
2	*	11340.00	32.12	2.18	34.30	54.00	-19.70	AVG	

REMARKS:

- (1) Measurement Value = Reading Level + Correct Factor.
- (2) Margin Level = Measurement Value - Limit Value.

Test Mode	IEEE 802.11ac (VHT40)	Test Date	2022/9/14
Test Frequency	5710MHz	Polarization	Vertical
Temp	25°C	Hum.	62%

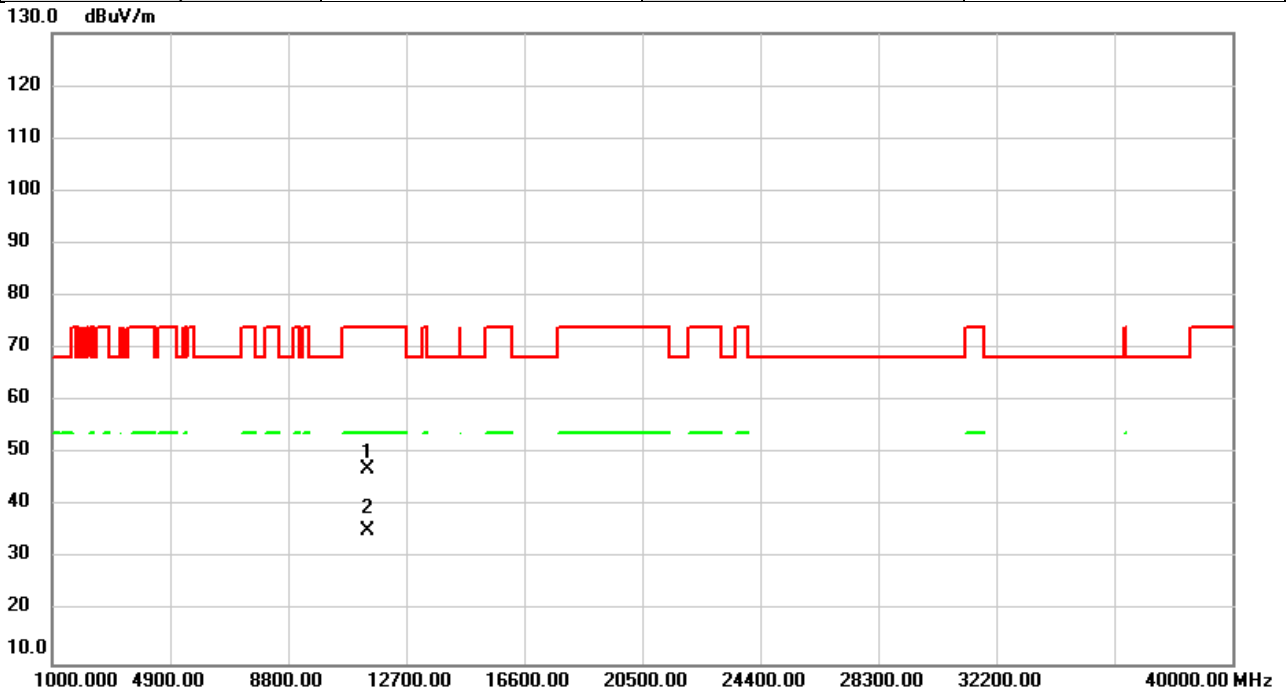

No.	Mk.	Freq. MHz	Reading Level dBuV	Correct Factor dB	Measure- ment dBuV/m	Limit dBuV/m	Over dB	Detector	Comment
1		11420.00	44.63	2.42	47.05	74.00	-26.95	peak	
2	*	11420.00	33.05	2.42	35.47	54.00	-18.53	AVG	

REMARKS:

- (1) Measurement Value = Reading Level + Correct Factor.
- (2) Margin Level = Measurement Value - Limit Value.

Test Mode	IEEE 802.11ac (VHT40)	Test Date	2022/9/14
Test Frequency	5710MHz	Polarization	Horizontal
Temp	25°C	Hum.	62%

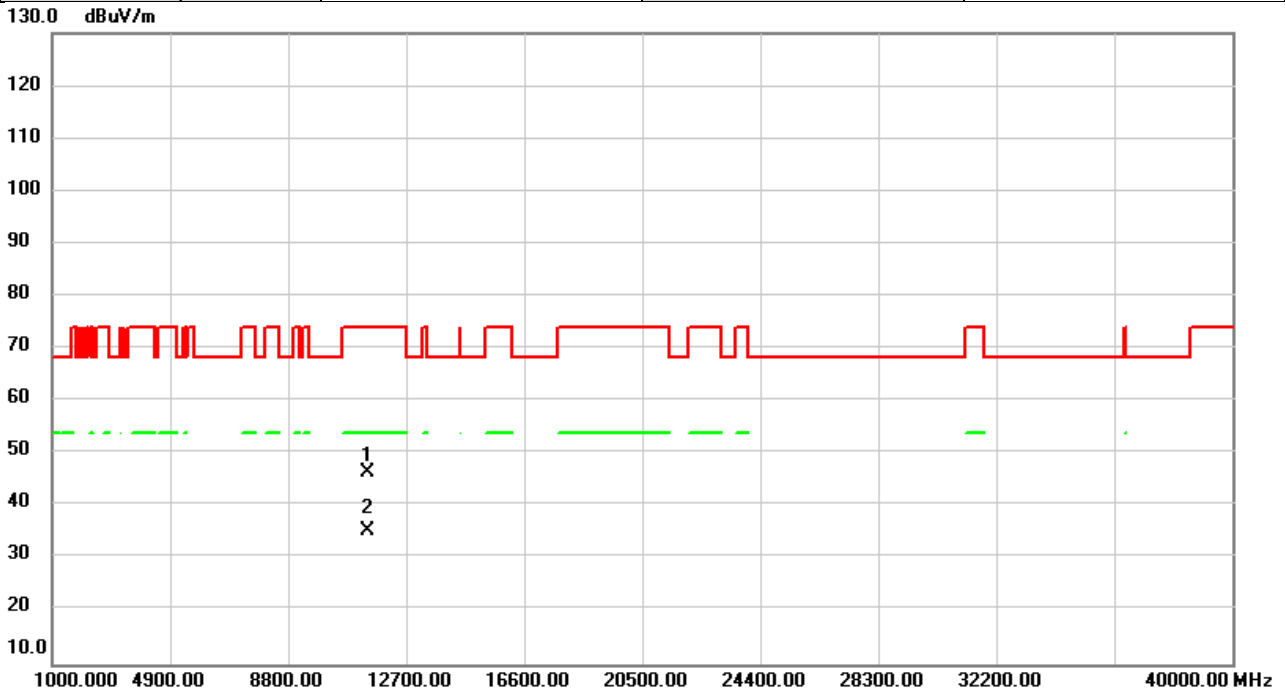

No.	Mk.	Freq.	Reading Level	Correct Factor	Measurement	Limit	Over	Detector	Comment
		MHz	dBuV	dB	dBuV/m	dBuV/m	dB		
1		11420.00	43.95	2.42	46.37	74.00	-27.63	peak	
2	*	11420.00	32.98	2.42	35.40	54.00	-18.60	AVG	

REMARKS:

- (1) Measurement Value = Reading Level + Correct Factor.
- (2) Margin Level = Measurement Value - Limit Value.

Test Mode	IEEE 802.11ac (VHT80)	Test Date	2022/9/14
Test Frequency	5210MHz	Polarization	Vertical
Temp	25°C	Hum.	62%

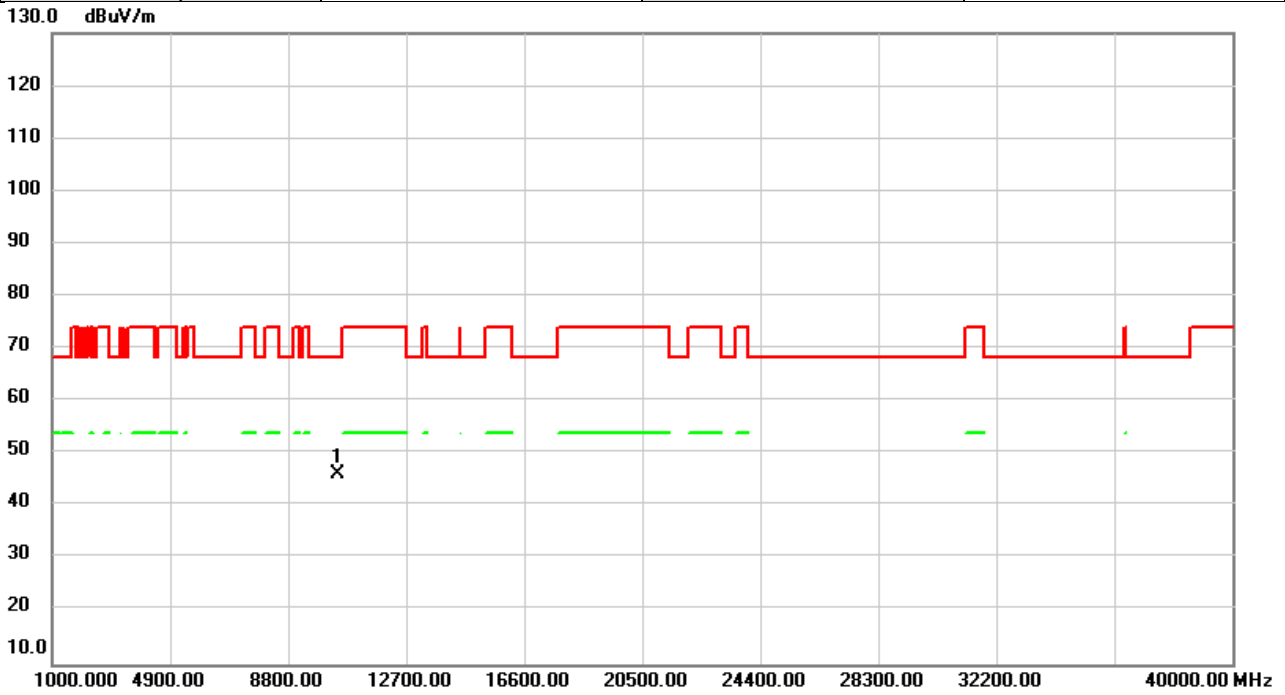

No.	Mk.	Freq. MHz	Reading Level dBuV	Correct Factor dB	Measure- ment dBuV/m	Limit dBuV/m	Over dB	Detector	Comment
1	*	10420.00	45.02	1.04	46.06	68.20	-22.14	peak	

REMARKS:

- (1) Measurement Value = Reading Level + Correct Factor.
- (2) Margin Level = Measurement Value - Limit Value.

Test Mode	IEEE 802.11ac (VHT80)	Test Date	2022/9/14
Test Frequency	5210MHz	Polarization	Horizontal
Temp	25°C	Hum.	62%

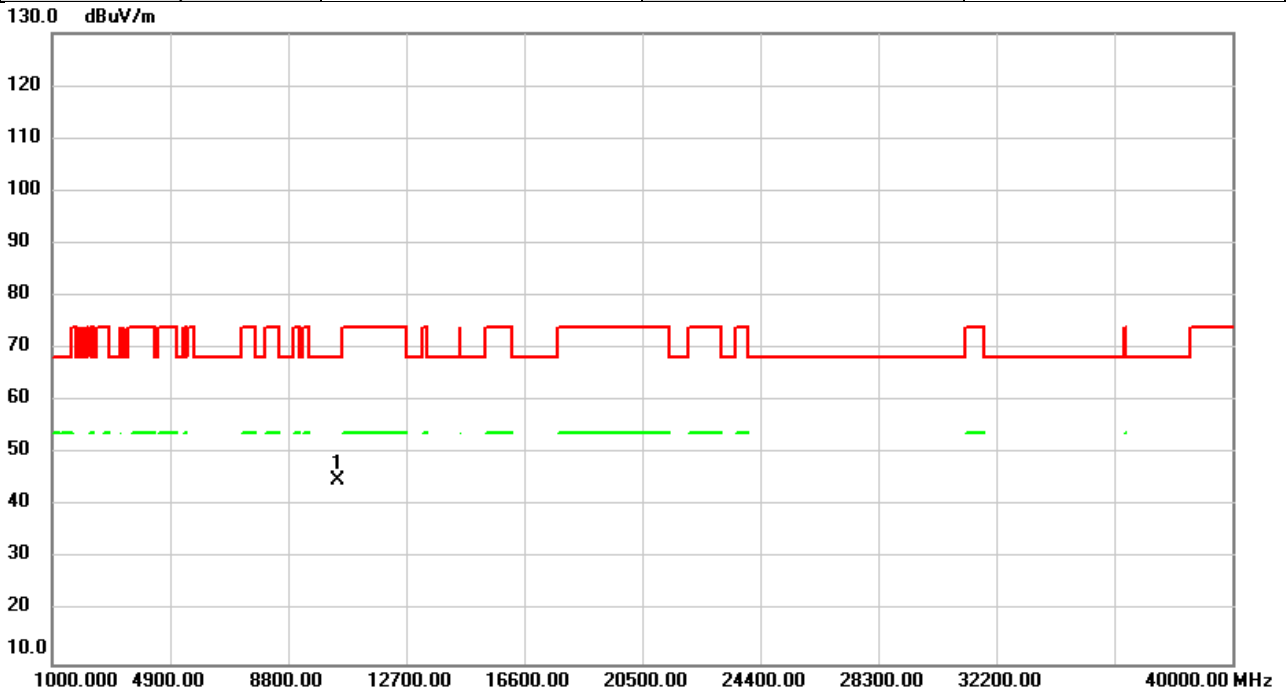

No.	Mk.	Freq.	Reading Level	Correct Factor	Measurement	Limit	Over	Detector	Comment
		MHz	dBuV	dB	dBuV/m	dBuV/m	dB		
1	*	10420.00	43.93	1.04	44.97	68.20	-23.23	peak	

REMARKS:

- (1) Measurement Value = Reading Level + Correct Factor.
- (2) Margin Level = Measurement Value - Limit Value.

Test Mode	IEEE 802.11ac (VHT80)	Test Date	2022/9/14
Test Frequency	5290MHz	Polarization	Vertical
Temp	25°C	Hum.	62%

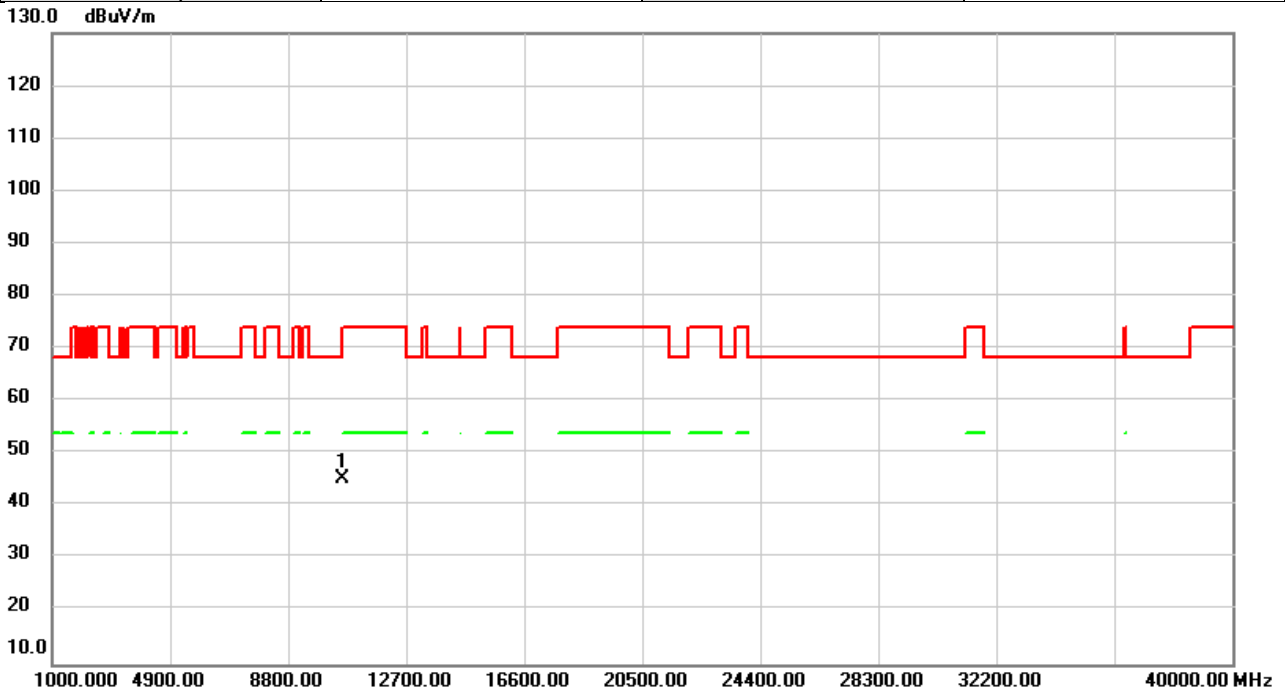

No.	Mk.	Freq.	Reading Level	Correct Factor	Measurement	Limit	Over	Detector	Comment
		MHz	dBuV	dB	dBuV/m	dBuV/m	dB		
1	*	10580.00	44.16	1.08	45.24	68.20	-22.96	peak	

REMARKS:

- (1) Measurement Value = Reading Level + Correct Factor.
- (2) Margin Level = Measurement Value - Limit Value.

Test Mode	IEEE 802.11ac (VHT80)	Test Date	2022/9/14
Test Frequency	5290MHz	Polarization	Horizontal
Temp	25°C	Hum.	62%

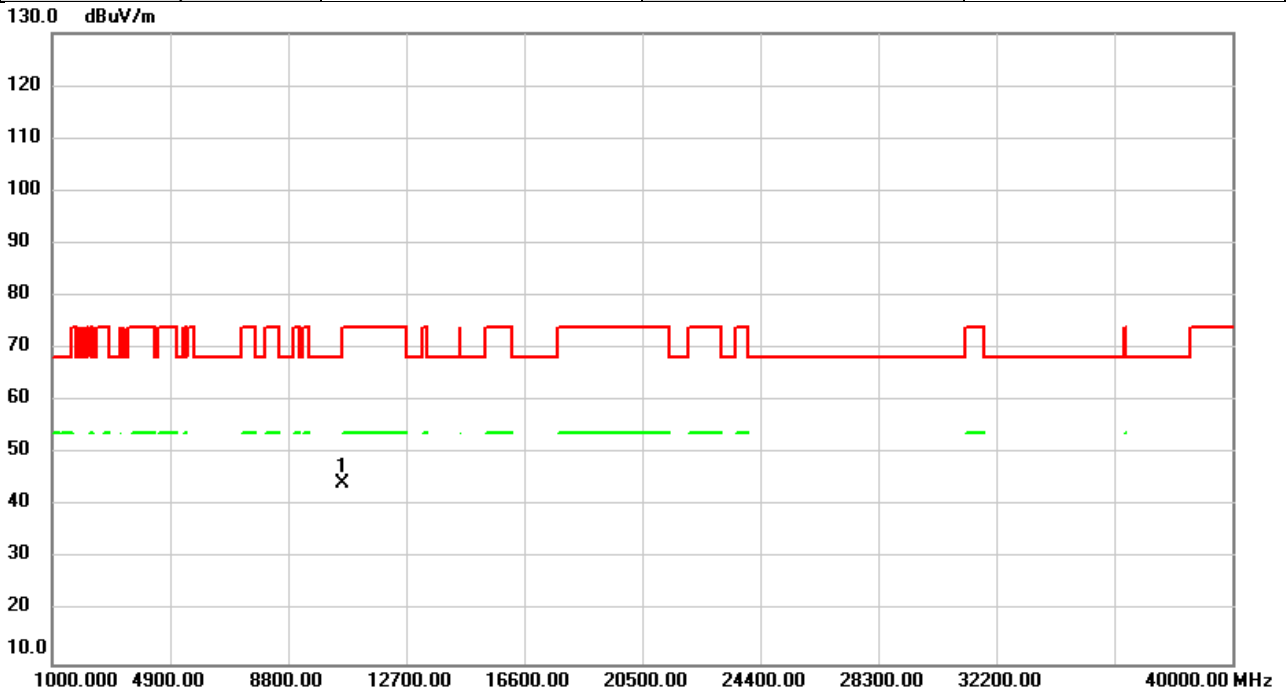

No.	Mk.	Freq.	Reading Level	Correct Factor	Measurement	Limit	Over	Detector	Comment
		MHz	dBuV	dB	dBuV/m	dBuV/m	dB		
1	*	10580.00	43.40	1.08	44.48	68.20	-23.72	peak	

REMARKS:

- (1) Measurement Value = Reading Level + Correct Factor.
- (2) Margin Level = Measurement Value - Limit Value.

Test Mode	IEEE 802.11ac (VHT80)	Test Date	2022/9/14
Test Frequency	5530MHz	Polarization	Vertical
Temp	25°C	Hum.	62%

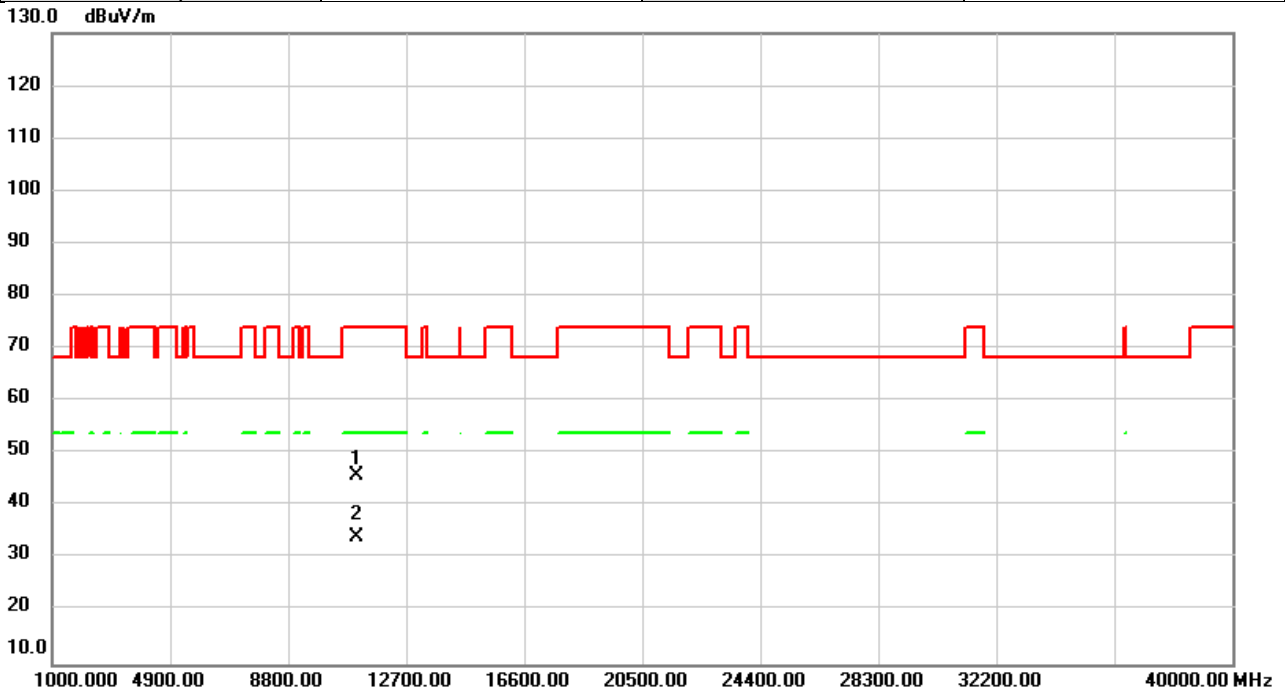

No.	Mk.	Freq. MHz	Reading Level dBuV	Correct Factor dB	Measure- ment dBuV/m	Limit dBuV/m	Over dB	Detector	Comment
1		11060.00	44.49	1.39	45.88	74.00	-28.12	peak	
2	*	11060.00	32.85	1.39	34.24	54.00	-19.76	AVG	

REMARKS:

- (1) Measurement Value = Reading Level + Correct Factor.
- (2) Margin Level = Measurement Value - Limit Value.

Test Mode	IEEE 802.11ac (VHT80)	Test Date	2022/9/14
Test Frequency	5530MHz	Polarization	Horizontal
Temp	25°C	Hum.	62%

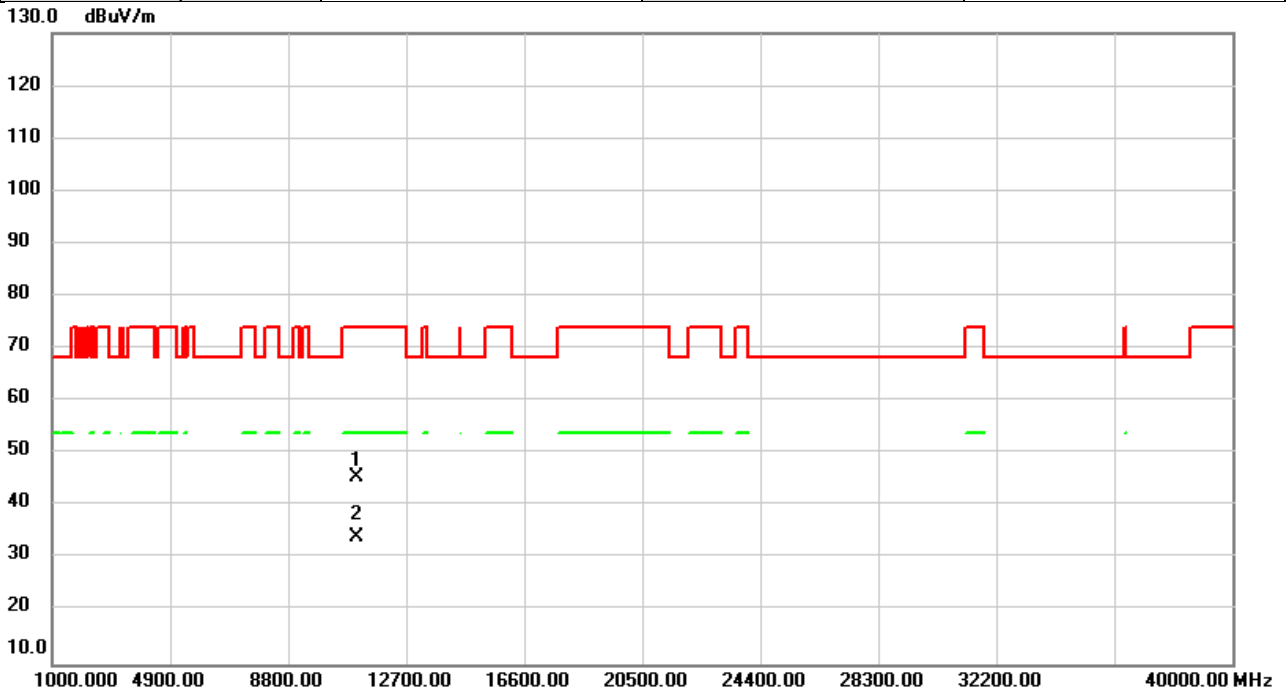

No.	Mk.	Freq. MHz	Reading Level dBuV	Correct Factor dB	Measure- ment dBuV/m	Limit dBuV/m	Over dB	Detector	Comment
1		11060.00	44.22	1.39	45.61	74.00	-28.39	peak	
2	*	11060.00	32.78	1.39	34.17	54.00	-19.83	AVG	

REMARKS:

- (1) Measurement Value = Reading Level + Correct Factor.
- (2) Margin Level = Measurement Value - Limit Value.

Test Mode	IEEE 802.11ac (VHT80)	Test Date	2022/9/14
Test Frequency	5690MHz	Polarization	Vertical
Temp	25°C	Hum.	62%

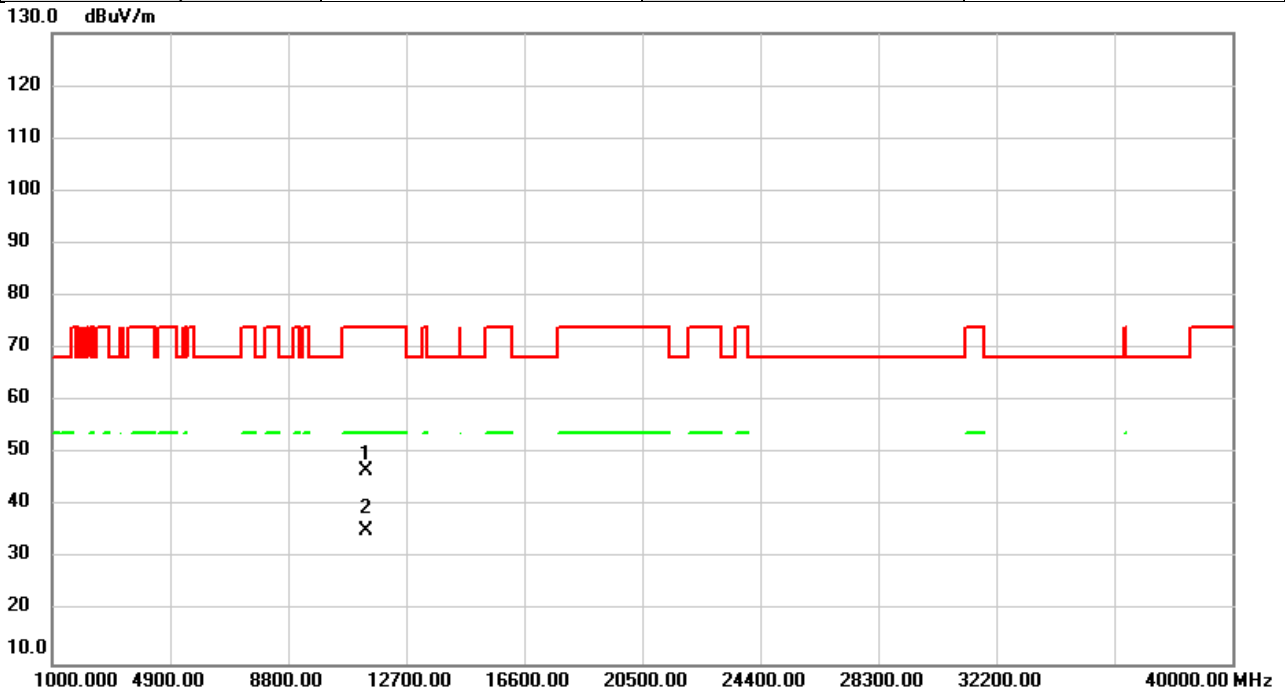

No.	Mk.	Freq.	Reading Level	Correct Factor	Measurement	Limit	Over	Detector	Comment
		MHz	dBuV	dB	dBuV/m	dBuV/m	dB		
1		11380.00	44.32	2.31	46.63	74.00	-27.37	peak	
2	*	11380.00	32.94	2.31	35.25	54.00	-18.75	AVG	

REMARKS:

- (1) Measurement Value = Reading Level + Correct Factor.
- (2) Margin Level = Measurement Value - Limit Value.

Test Mode	IEEE 802.11ac (VHT80)	Test Date	2022/9/14
Test Frequency	5690MHz	Polarization	Horizontal
Temp	25°C	Hum.	62%

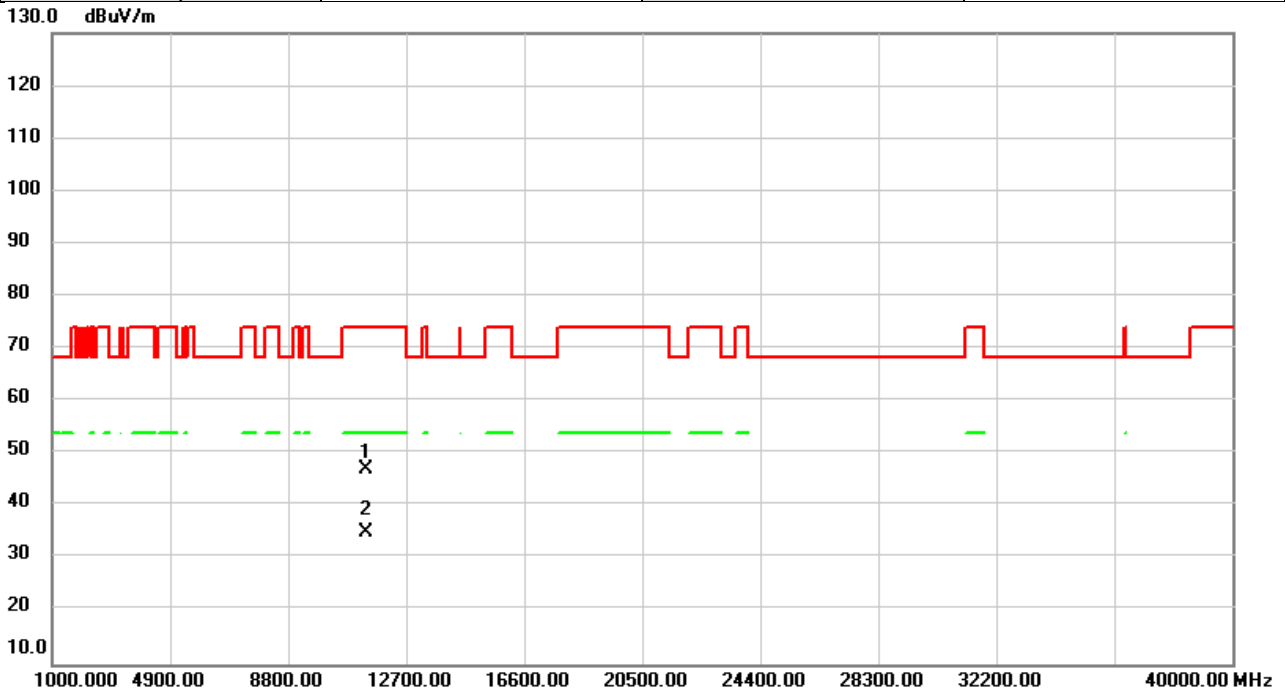

No.	Mk.	Freq.	Reading Level	Correct Factor	Measurement	Limit	Over	Detector	Comment
		MHz	dBuV	dB	dBuV/m	dBuV/m	dB		
1		11380.00	44.78	2.31	47.09	74.00	-26.91	peak	
2	*	11380.00	32.86	2.31	35.17	54.00	-18.83	AVG	

REMARKS:

- (1) Measurement Value = Reading Level + Correct Factor.
- (2) Margin Level = Measurement Value - Limit Value.

APPENDIX D BANDWIDTH

Test Mode | IEEE 802.11a_Aux Antenna

Test Frequency (MHz)	26 dB Bandwidth (MHz)	99 % Occupied Bandwidth (MHz)	Limit
5180	25.45	17.60	No limit
5200	21.90	17.30	No limit
5240	22.50	17.40	No limit

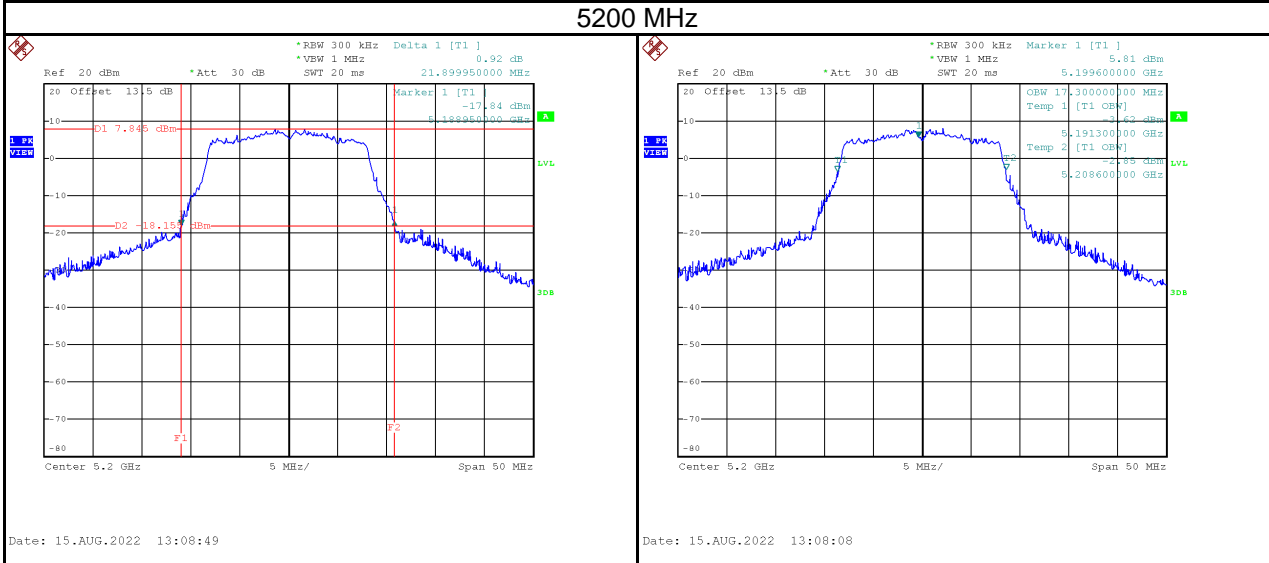
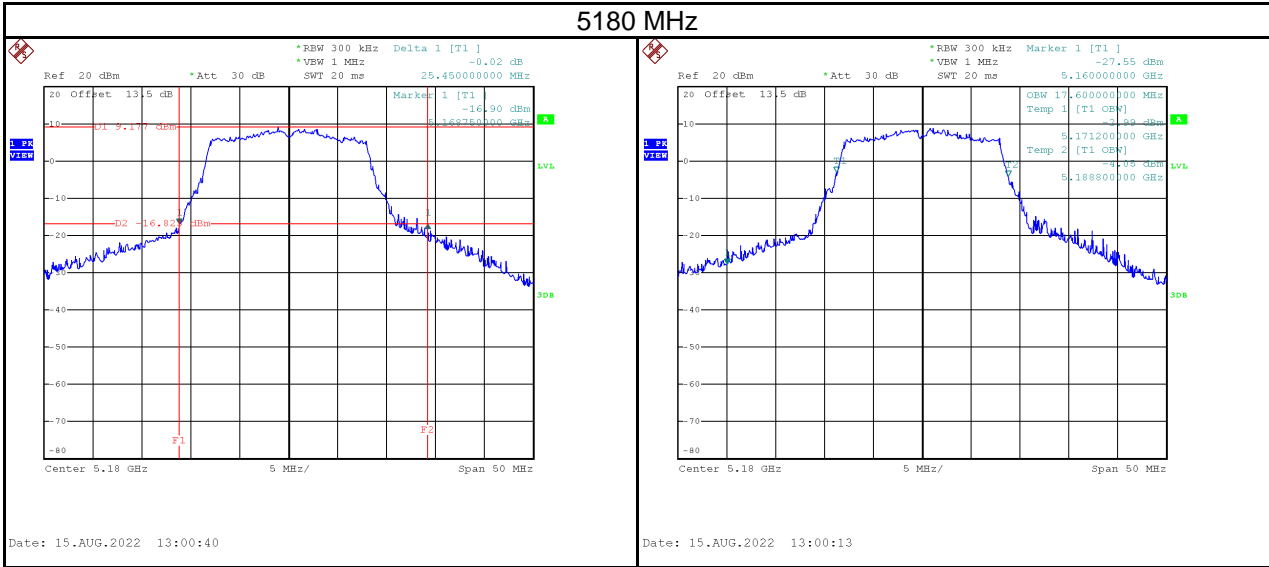

5240 MHz

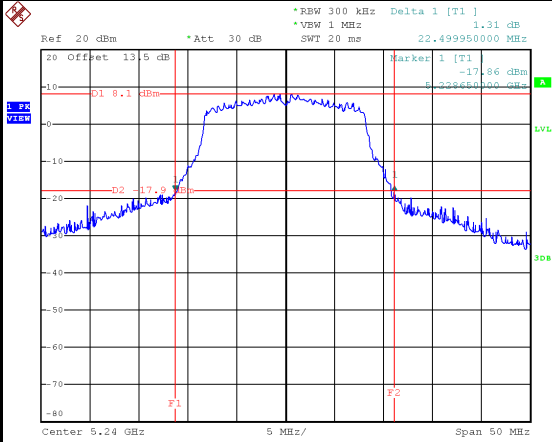

Date: 15.AUG.2022 13:24:42

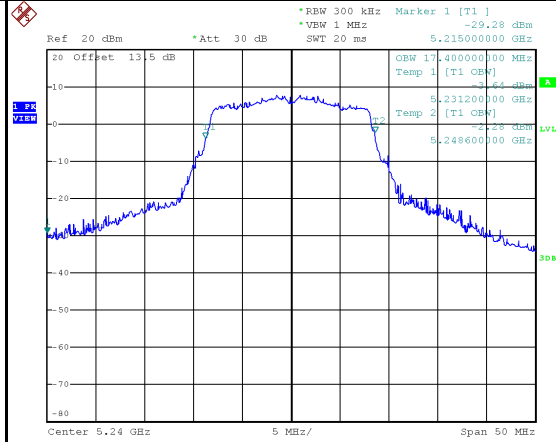

Date: 15.AUG.2022 13:22:56

Test Frequency (MHz)	26 dB Bandwidth (MHz)	99 % Occupied Bandwidth (MHz)	Limit
5260	23.60	17.50	No limit
5300	23.15	17.50	No limit
5320	23.49	17.40	No limit

5260 MHz

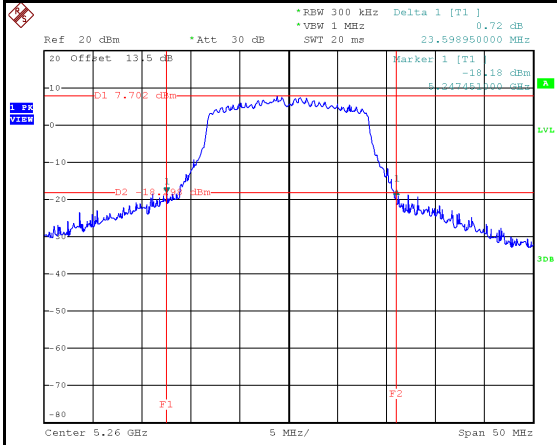

Date: 15.AUG.2022 13:32:02

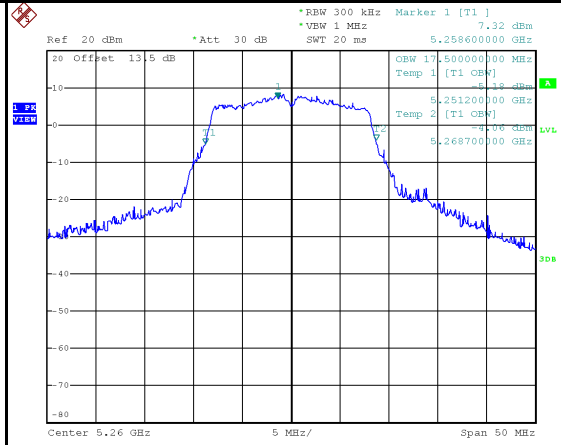

Date: 15.AUG.2022 13:30:00

5300 MHz

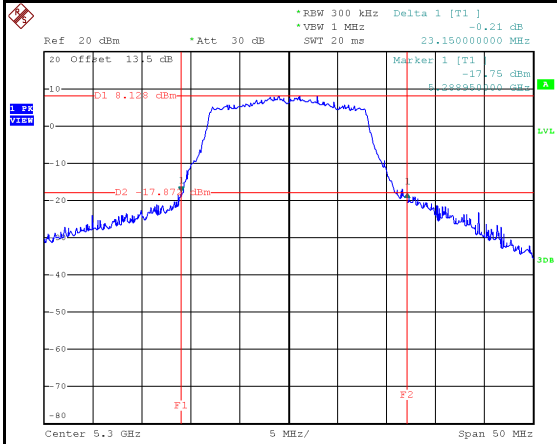

Date: 15.AUG.2022 14:43:57

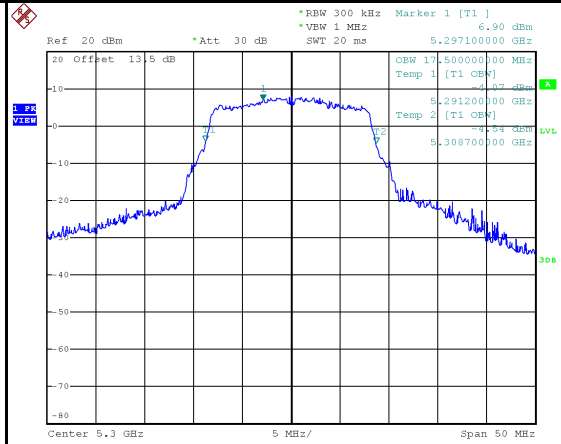

Date: 15.AUG.2022 14:43:27

5320 MHz

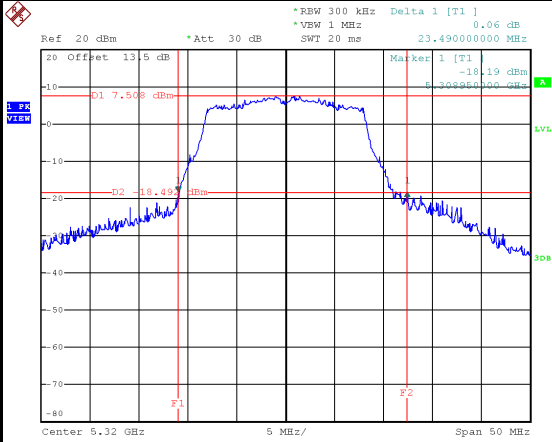

Date: 15.AUG.2022 14:53:26

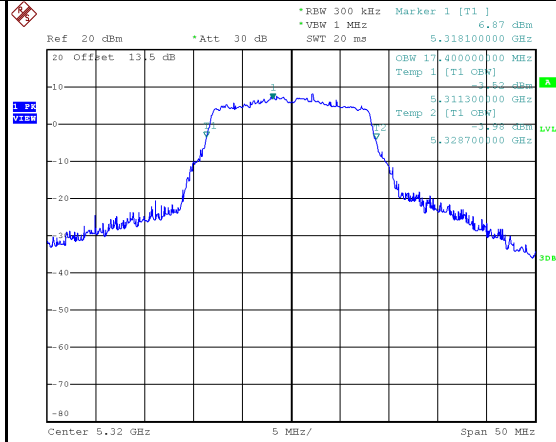

Date: 15.AUG.2022 14:52:49

Test Frequency (MHz)	26 dB Bandwidth (MHz)	99 % Occupied Bandwidth (MHz)	Limit
5500	24.50	17.40	No limit
5580	25.90	17.40	No limit
5700	31.59	18.10	No limit

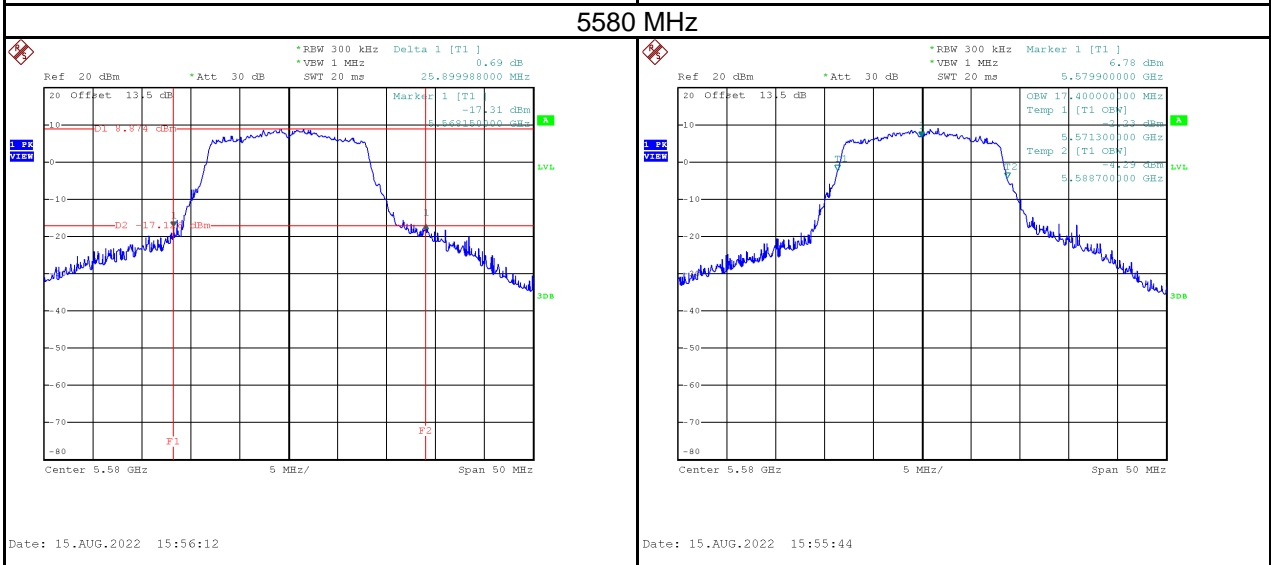
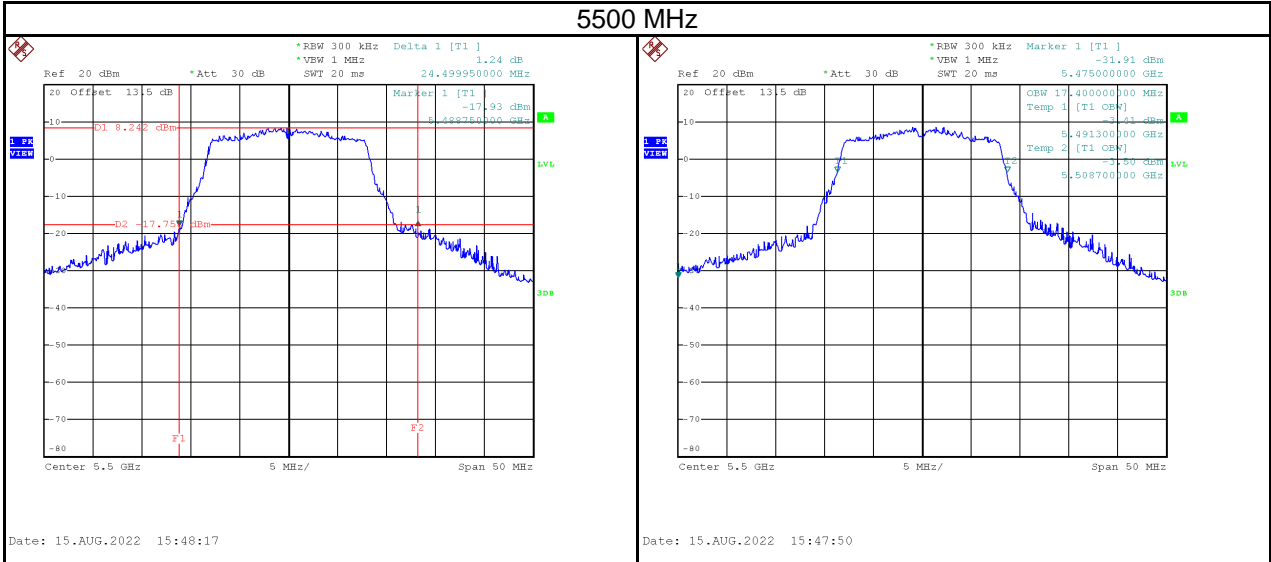

5700 MHz

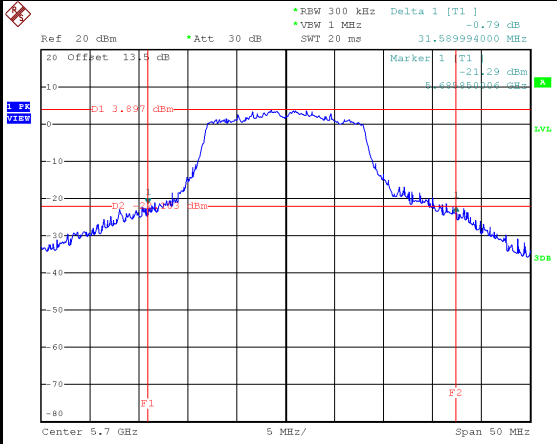

Date: 17.AUG.2022 19:42:16

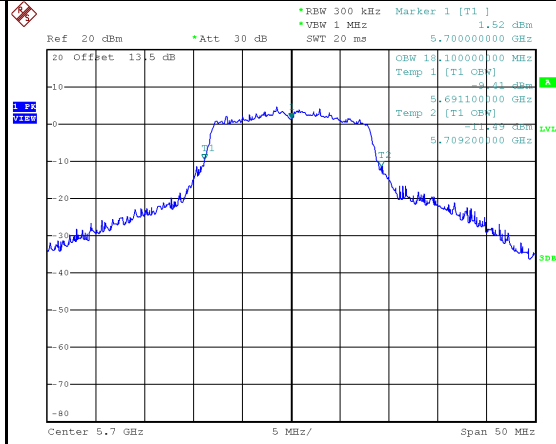

Date: 17.AUG.2022 19:41:42

Test Mode	IEEE 802.11ac (VHT20)_Aux Antenna
-----------	-----------------------------------

Test Frequency (MHz)	26 dB Bandwidth (MHz)	99 % Occupied Bandwidth (MHz)	Limit
5180	22.60	18.40	No limit
5200	23.65	18.40	No limit
5240	22.89	18.40	No limit

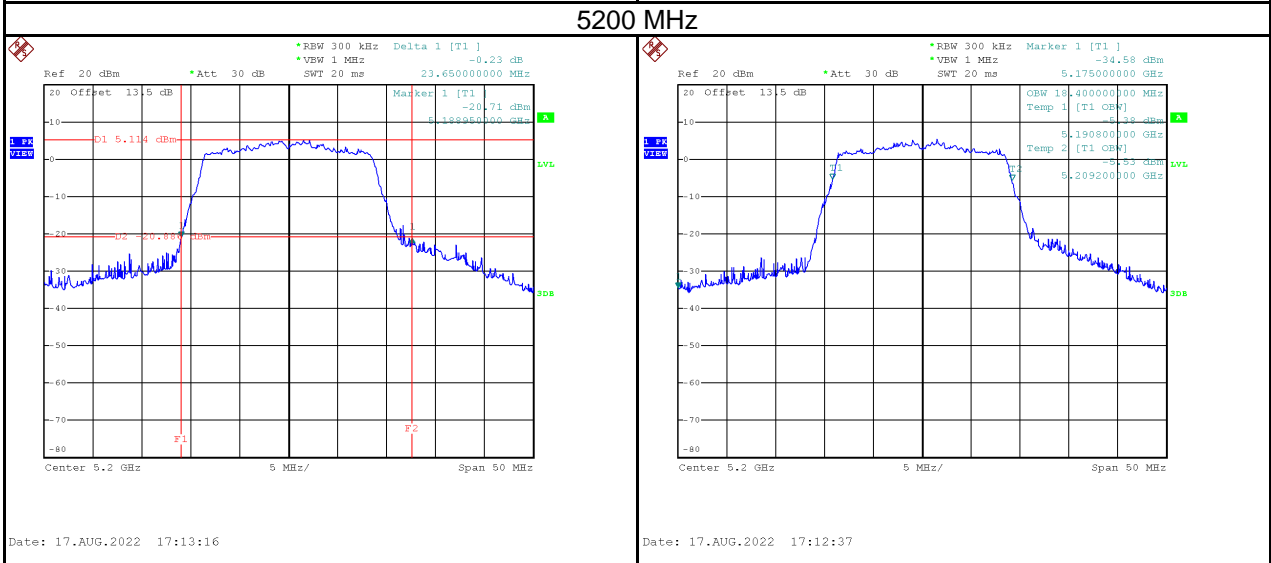
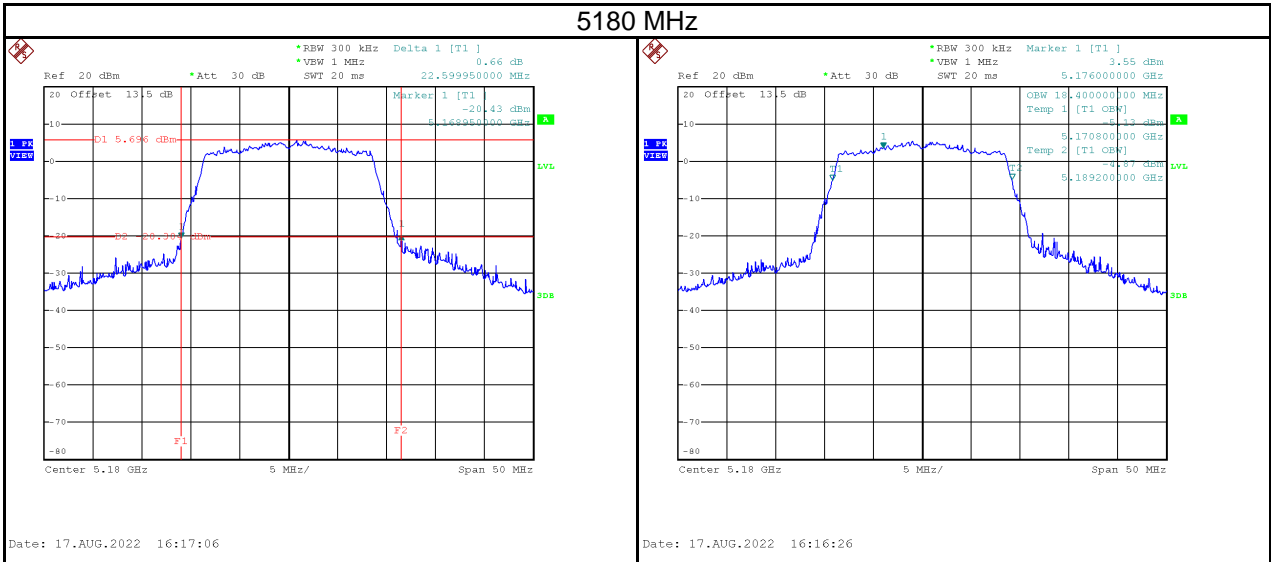

5240 MHz

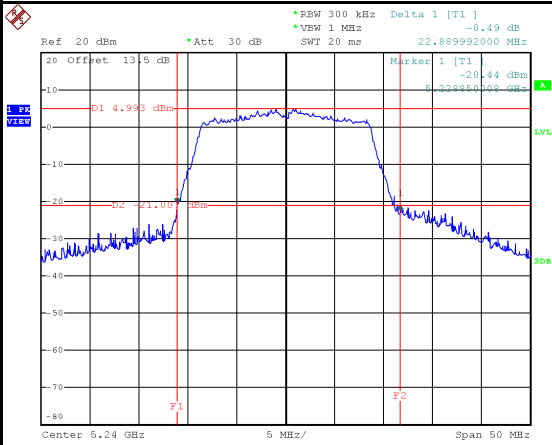

Date: 17.AUG.2022 17:34:24

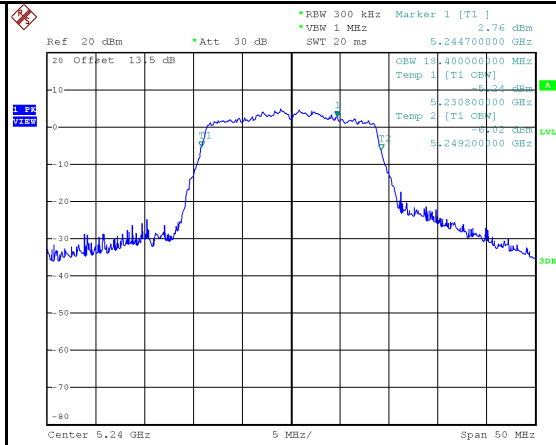

Date: 17.AUG.2022 17:33:41

Test Frequency (MHz)	26 dB Bandwidth (MHz)	99 % Occupied Bandwidth (MHz)	Limit
5260	27.70	18.40	No limit
5300	25.59	18.50	No limit
5320	23.05	18.40	No limit

5260 MHz

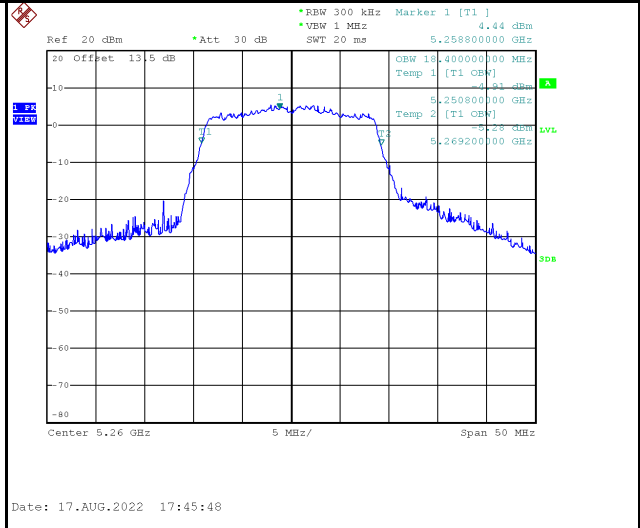
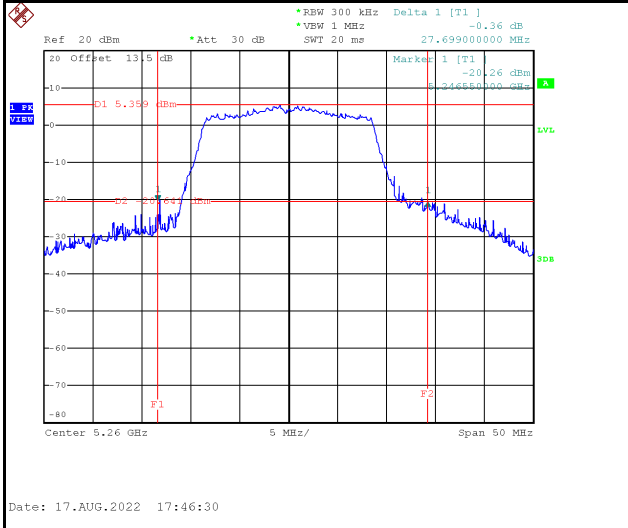

5300 MHz

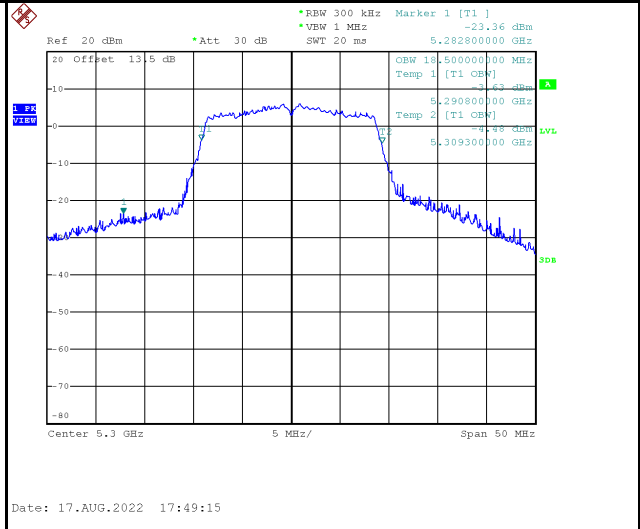
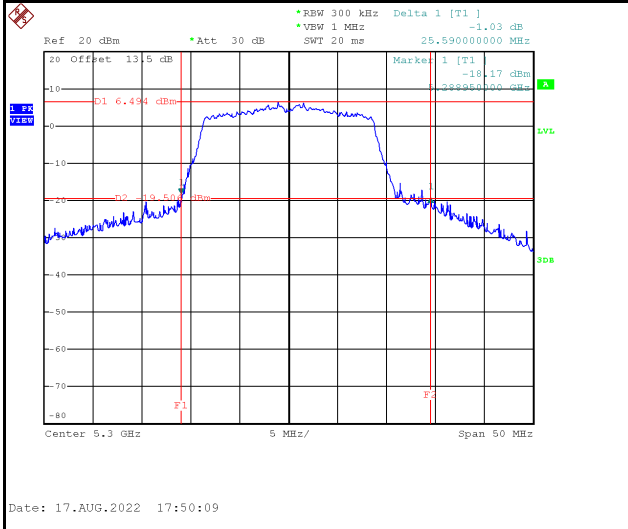

5320 MHz

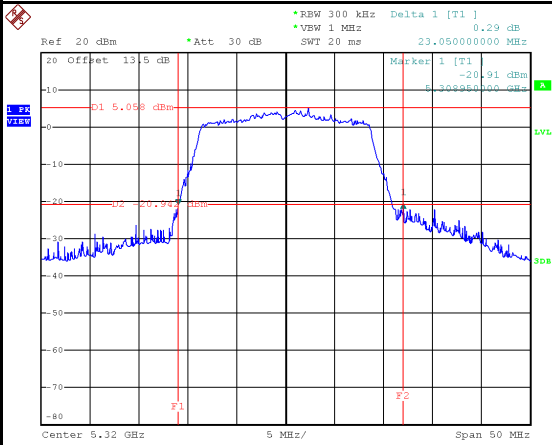

Date: 17.AUG.2022 17:54:56

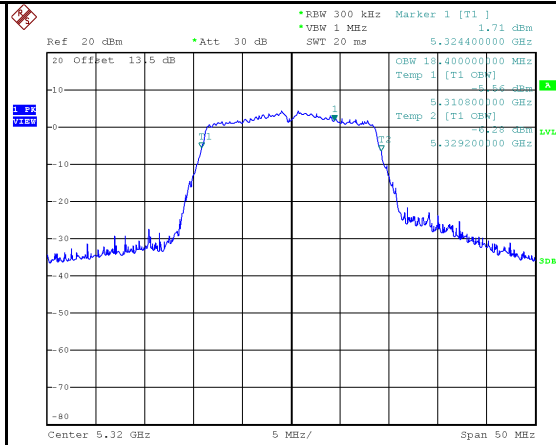

Date: 17.AUG.2022 17:54:17

Test Frequency (MHz)	26 dB Bandwidth (MHz)	99 % Occupied Bandwidth (MHz)	Limit
5500	26.65	18.50	No limit
5580	30.30	18.60	No limit
5700	31.10	18.80	No limit

5500 MHz

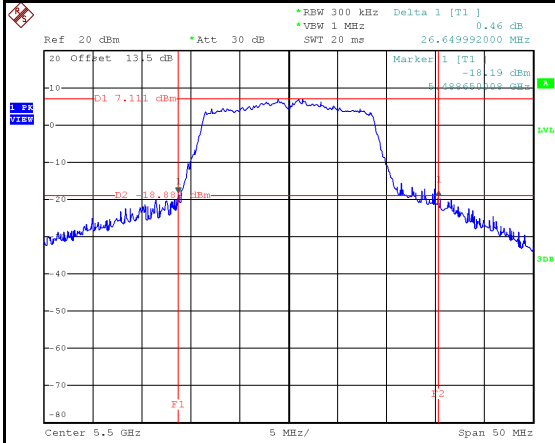

Date: 17.AUG.2022 16:03:12

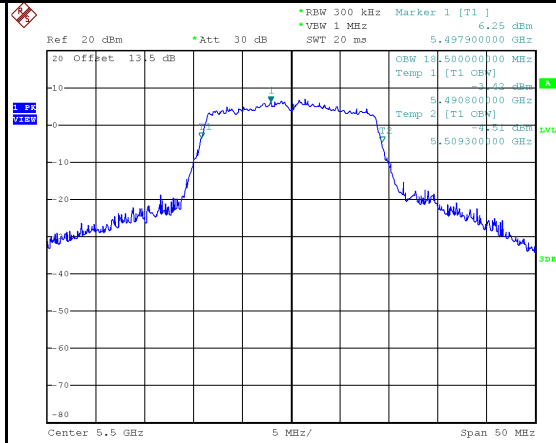

Date: 17.AUG.2022 16:02:35

5580 MHz

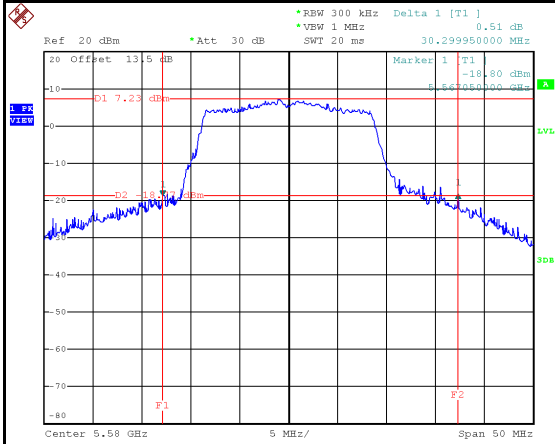

Date: 17.AUG.2022 16:07:55

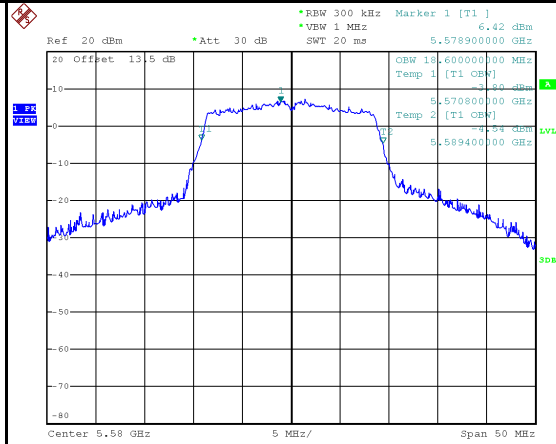

Date: 17.AUG.2022 16:07:20

5700 MHz

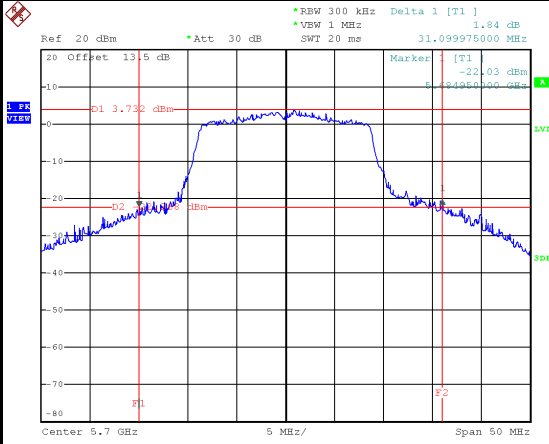

Date: 17.AUG.2022 19:48:06

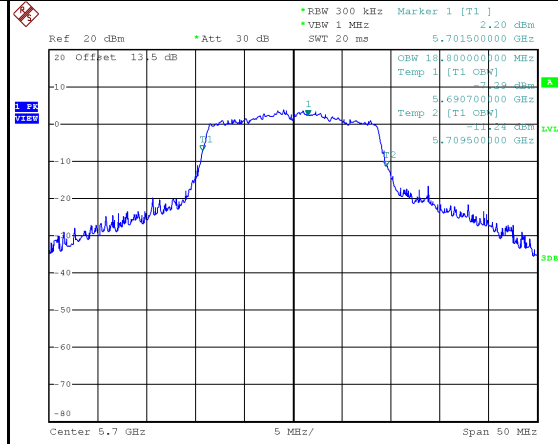

Date: 17.AUG.2022 19:47:38

Test Mode	IEEE 802.11ac (VHT40)_Aux Antenna
-----------	-----------------------------------

Test Frequency (MHz)	26 dB Bandwidth (MHz)	99 % Occupied Bandwidth (MHz)	Limit
5190	57.39	37.40	No limit
5230	59.39	37.60	No limit

5190 MHz

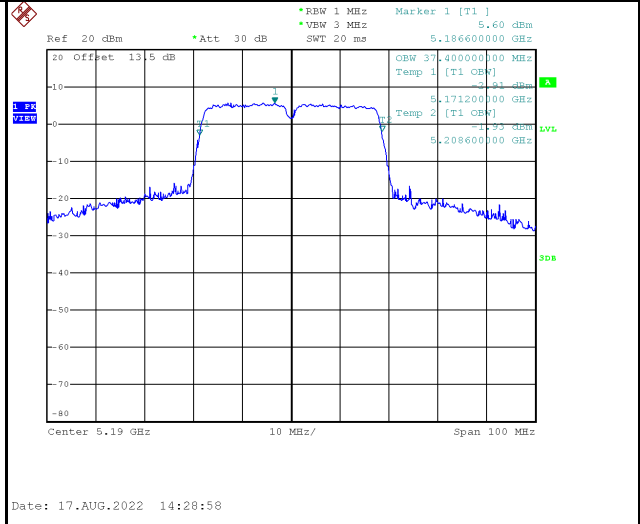
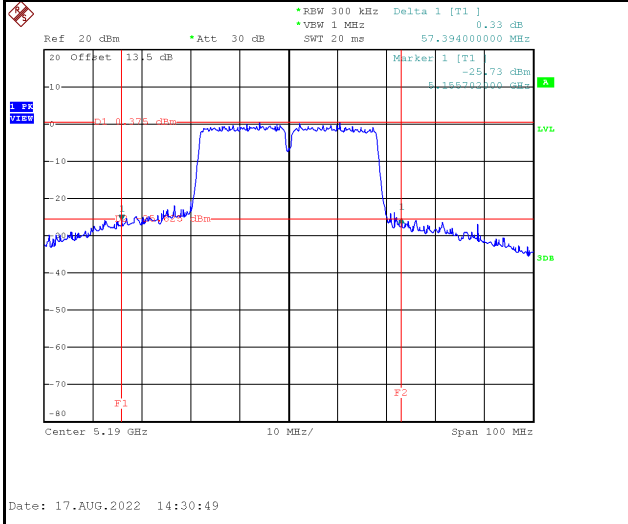

5230 MHz

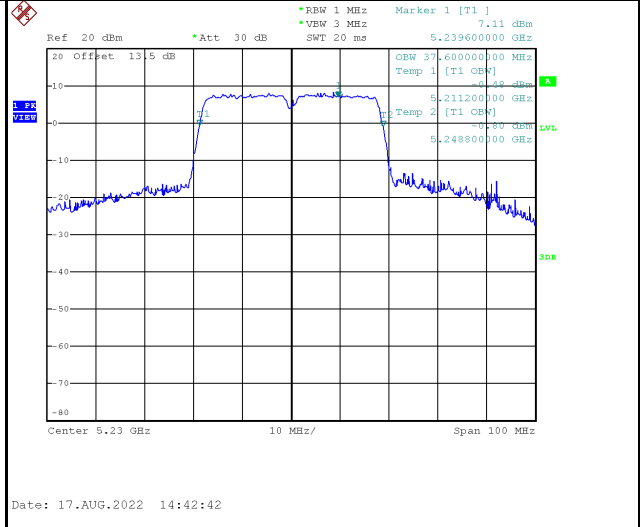
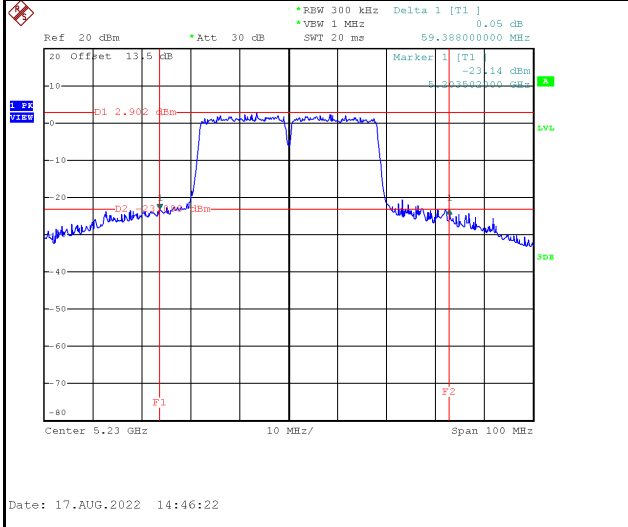

Test Frequency (MHz)	26 dB Bandwidth (MHz)	99 % Occupied Bandwidth (MHz)	Limit
5270	54.20	37.60	No limit
5310	53.61	37.60	No limit

5270 MHz

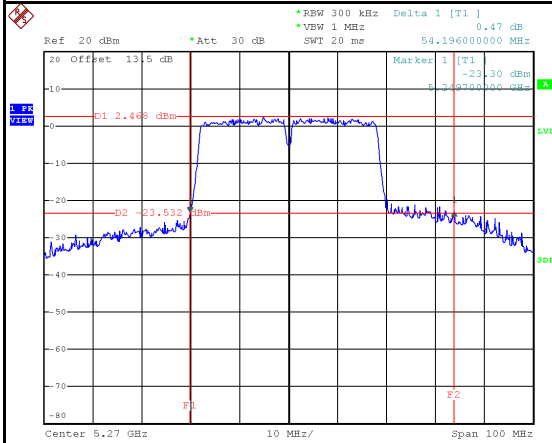

Date: 17.AUG.2022 14:56:25

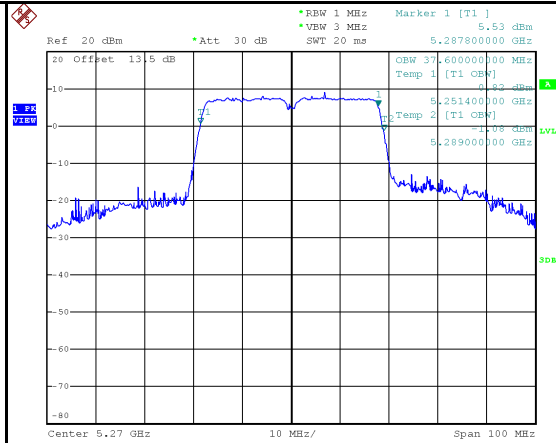

Date: 17.AUG.2022 14:55:07

5310 MHz

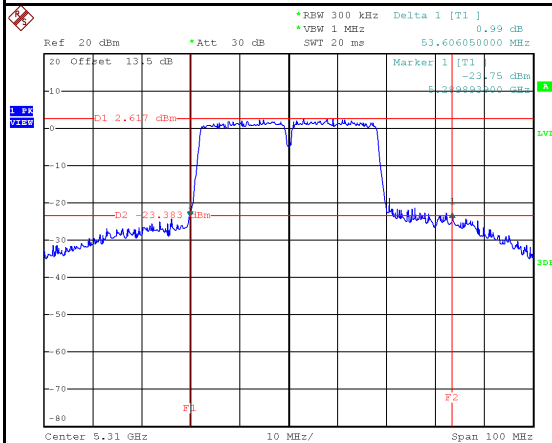

Date: 17.AUG.2022 15:00:53

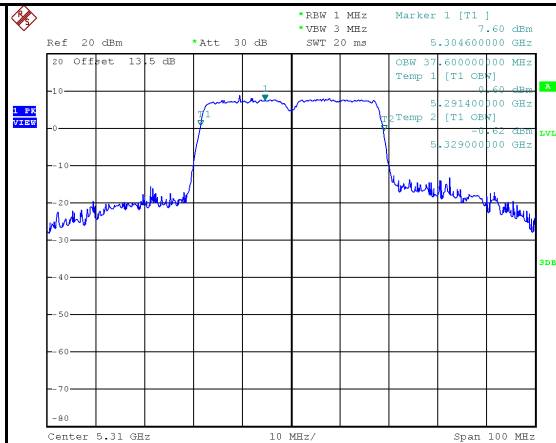

Date: 17.AUG.2022 14:59:29

Test Frequency (MHz)	26 dB Bandwidth (MHz)	99 % Occupied Bandwidth (MHz)	Limit
5510	49.00	37.40	No limit
5550	58.80	37.60	No limit
5670	66.10	37.80	No limit

5510 MHz

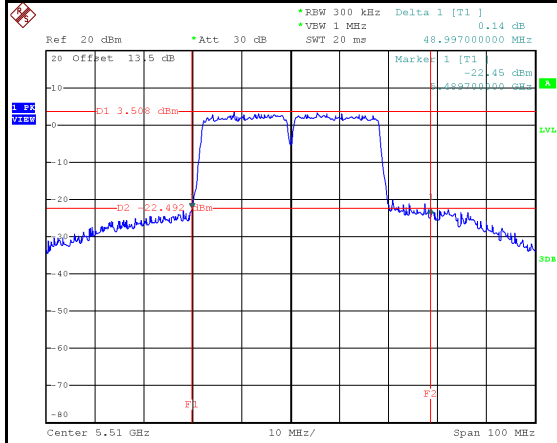

Date: 17.AUG.2022 15:12:56

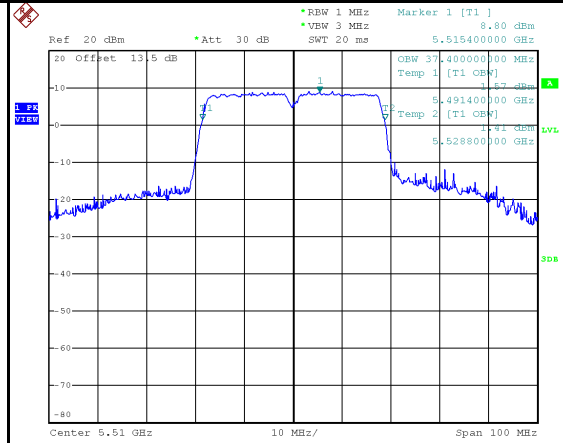

Date: 17.AUG.2022 15:11:37

5550 MHz

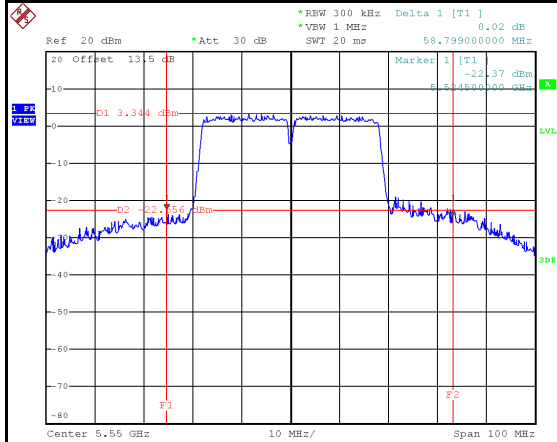

Date: 17.AUG.2022 15:18:55

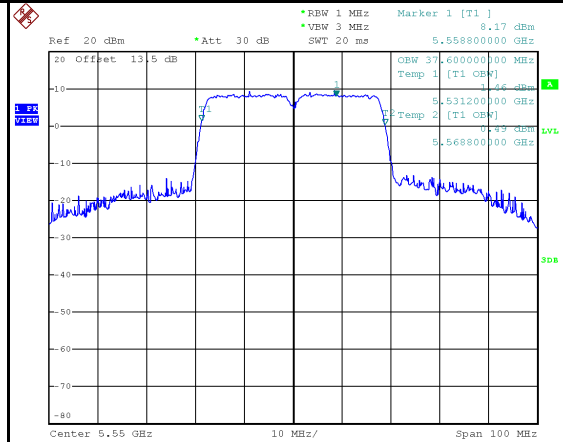

Date: 17.AUG.2022 15:18:11

5670 MHz

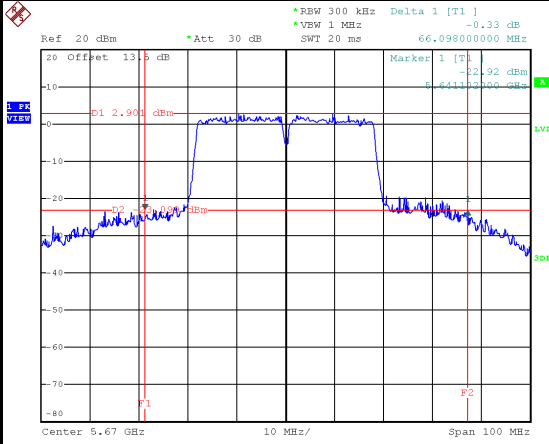

Date: 17.AUG.2022 15:51:39

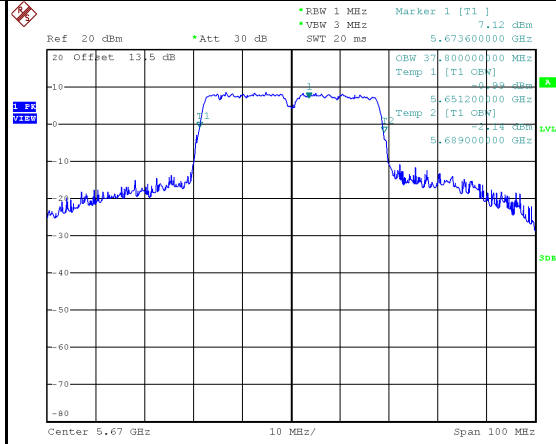

Date: 17.AUG.2022 15:50:44

Test Mode	IEEE 802.11ac (VHT80)_Aux Antenna
-----------	-----------------------------------

Test Frequency (MHz)	26 dB Bandwidth (MHz)	99 % Occupied Bandwidth (MHz)	Limit
5210	92.41	76.80	No limit

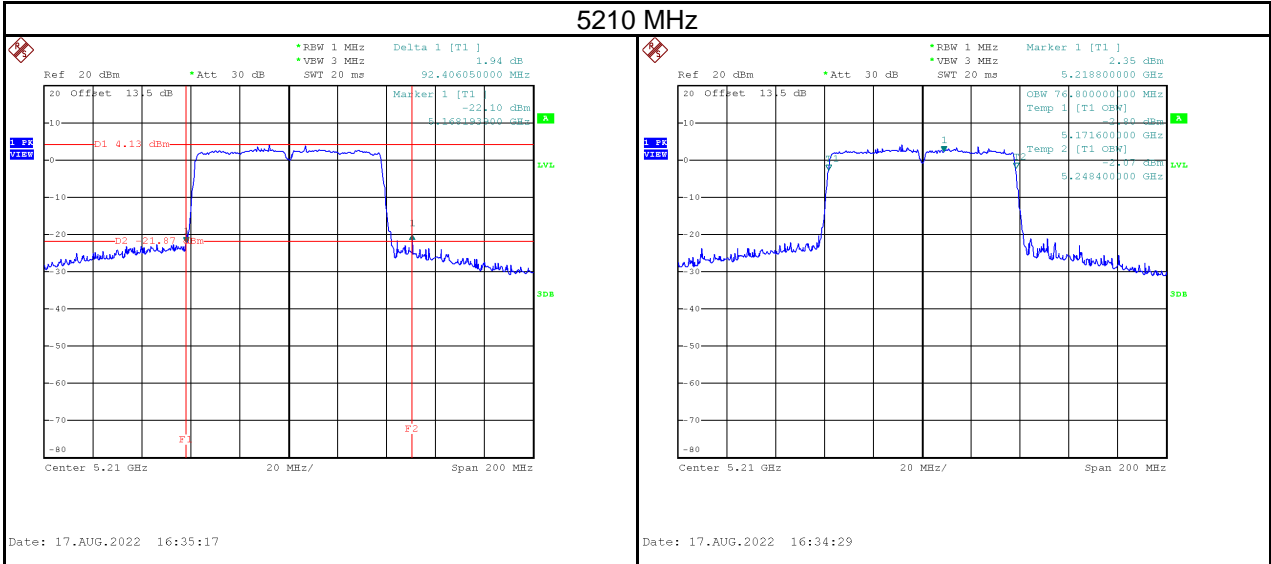

Test Frequency (MHz)	26 dB Bandwidth (MHz)	99 % Occupied Bandwidth (MHz)	Limit
5290	101.59	76.80	No limit

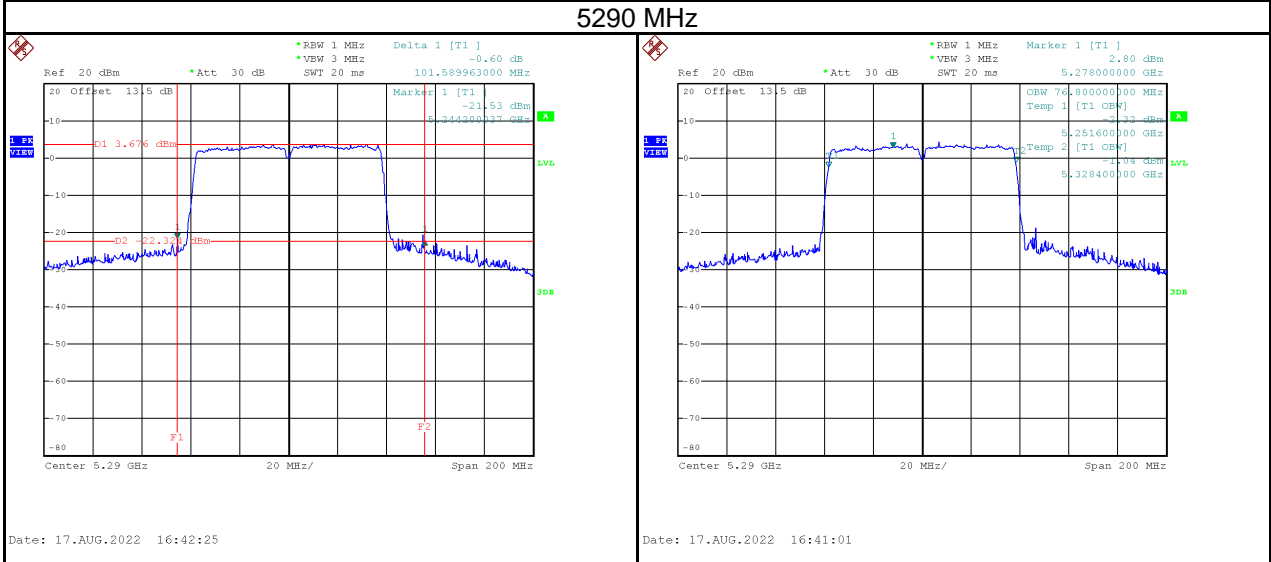

Test Frequency (MHz)	26 dB Bandwidth (MHz)	99 % Occupied Bandwidth (MHz)	Limit
5530	91.40	76.80	No limit

5530 MHz

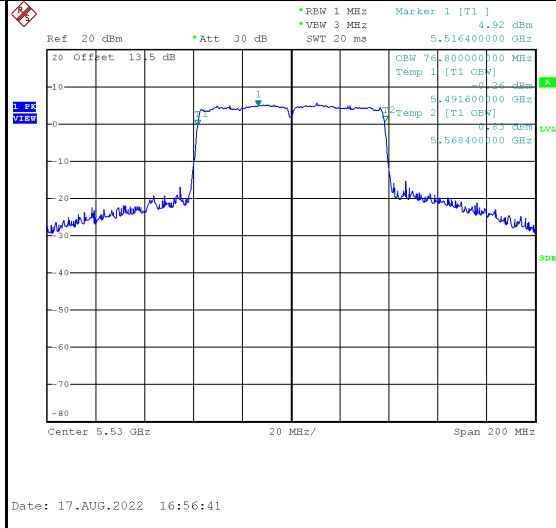
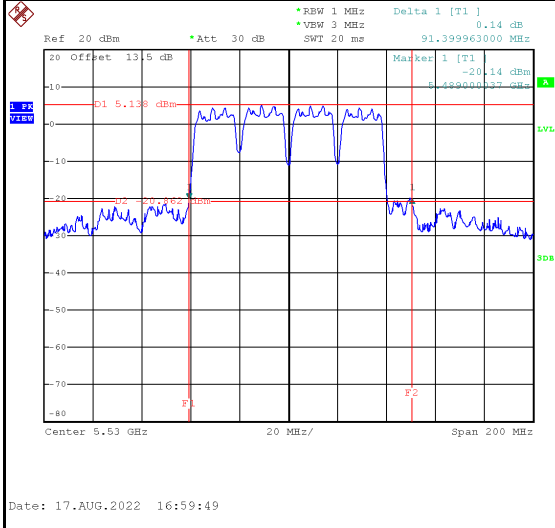

APPENDIX E CONDUCTED OUTPUT POWER

Test Mode	IEEE 802.11a_Main Antenna	Tested Date	2022/8/17
-----------	---------------------------	-------------	-----------

Frequency (MHz)	Conducted Power (dBm)	Conducted Power (W)	Max. Limit (dBm)	Max. Limit (W)	Result
5180	8.87	0.0077	23.98	0.2500	Complies
5200	8.71	0.0074	23.98	0.2500	Complies
5240	9.03	0.0080	23.98	0.2500	Complies
5260	9.22	0.0084	23.98	0.2500	Complies
5300	9.32	0.0086	23.98	0.2500	Complies
5320	9.20	0.0083	23.98	0.2500	Complies
5500	9.27	0.0085	23.98	0.2500	Complies
5580	9.55	0.0090	23.98	0.2500	Complies
5700	9.55	0.0090	23.98	0.2500	Complies

Test Mode	IEEE 802.11a_Aux Antenna	Tested Date	2022/8/17
-----------	--------------------------	-------------	-----------

Frequency (MHz)	Conducted Power (dBm)	Conducted Power (W)	Max. Limit (dBm)	Max. Limit (W)	Result
5180	9.73	0.0094	23.98	0.2500	Complies
5200	9.63	0.0092	23.98	0.2500	Complies
5240	9.69	0.0093	23.98	0.2500	Complies
5260	9.96	0.0099	23.98	0.2500	Complies
5300	9.95	0.0099	23.98	0.2500	Complies
5320	9.92	0.0098	23.98	0.2500	Complies
5500	9.92	0.0098	23.98	0.2500	Complies
5580	9.85	0.0097	23.98	0.2500	Complies
5700	9.94	0.0099	23.98	0.2500	Complies

Test Mode	IEEE 802.11a_Total	Tested Date	2022/8/17
-----------	--------------------	-------------	-----------

Frequency (MHz)	Conducted Power (dBm)	Conducted Power (W)	Max. Limit (dBm)	Max. Limit (W)	Result
5180	12.33	0.0171	23.98	0.2500	Complies
5200	12.20	0.0166	23.98	0.2500	Complies
5240	12.38	0.0173	23.98	0.2500	Complies
5260	12.62	0.0183	23.98	0.2500	Complies
5300	12.66	0.0184	23.98	0.2500	Complies
5320	12.59	0.0181	23.98	0.2500	Complies
5500	12.62	0.0183	23.98	0.2500	Complies
5580	12.71	0.0187	23.98	0.2500	Complies
5700	12.76	0.0189	23.98	0.2500	Complies

Test Mode	IEEE 802.11n (HT20) _Main Antenna	Tested Date	2022/8/17
-----------	-----------------------------------	-------------	-----------

Frequency (MHz)	Conducted Power (dBm)	Conducted Power (W)	Max. Limit (dBm)	Max. Limit (W)	Result
5180	8.74	0.0075	23.98	0.2500	Complies
5200	8.64	0.0073	23.98	0.2500	Complies
5240	8.95	0.0079	23.98	0.2500	Complies
5260	8.79	0.0076	23.98	0.2500	Complies
5300	8.90	0.0078	23.98	0.2500	Complies
5320	8.82	0.0076	23.98	0.2500	Complies
5500	9.13	0.0082	23.98	0.2500	Complies
5580	9.54	0.0090	23.98	0.2500	Complies
5700	9.20	0.0083	23.98	0.2500	Complies

Test Mode	IEEE 802.11n (HT20) _Aux Antenna	Tested Date	2022/8/17
-----------	----------------------------------	-------------	-----------

Frequency (MHz)	Conducted Power (dBm)	Conducted Power (W)	Max. Limit (dBm)	Max. Limit (W)	Result
5180	9.55	0.0090	23.98	0.2500	Complies
5200	9.42	0.0087	23.98	0.2500	Complies
5240	9.64	0.0092	23.98	0.2500	Complies
5260	9.90	0.0098	23.98	0.2500	Complies
5300	9.89	0.0097	23.98	0.2500	Complies
5320	9.79	0.0095	23.98	0.2500	Complies
5500	9.62	0.0092	23.98	0.2500	Complies
5580	9.84	0.0096	23.98	0.2500	Complies
5700	9.94	0.0099	23.98	0.2500	Complies

Test Mode	IEEE 802.11n (HT20) _Total	Tested Date	2022/8/17
-----------	----------------------------	-------------	-----------

Frequency (MHz)	Conducted Power (dBm)	Conducted Power (W)	Max. Limit (dBm)	Max. Limit (W)	Result
5180	12.17	0.0165	23.98	0.2500	Complies
5200	12.06	0.0161	23.98	0.2500	Complies
5240	12.32	0.0171	23.98	0.2500	Complies
5260	12.39	0.0173	23.98	0.2500	Complies
5300	12.43	0.0175	23.98	0.2500	Complies
5320	12.34	0.0171	23.98	0.2500	Complies
5500	12.39	0.0173	23.98	0.2500	Complies
5580	12.70	0.0186	23.98	0.2500	Complies
5700	12.60	0.0182	23.98	0.2500	Complies

Test Mode	IEEE 802.11n (HT40)_Main Antenna	Tested Date	2022/8/17
-----------	----------------------------------	-------------	-----------

Frequency (MHz)	Conducted Power (dBm)	Conducted Power (W)	Max. Limit (dBm)	Max. Limit (W)	Result
5190	9.07	0.0081	23.98	0.2500	Complies
5230	9.42	0.0087	23.98	0.2500	Complies
5270	8.41	0.0069	23.98	0.2500	Complies
5310	8.46	0.0070	23.98	0.2500	Complies
5510	9.74	0.0094	23.98	0.2500	Complies
5550	9.72	0.0094	23.98	0.2500	Complies
5670	9.71	0.0094	23.98	0.2500	Complies

Test Mode	IEEE 802.11n (HT40)_Aux Antenna	Tested Date	2022/8/17
-----------	---------------------------------	-------------	-----------

Frequency (MHz)	Conducted Power (dBm)	Conducted Power (W)	Max. Limit (dBm)	Max. Limit (W)	Result
5190	9.91	0.0098	23.98	0.2500	Complies
5230	9.89	0.0097	23.98	0.2500	Complies
5270	9.61	0.0091	23.98	0.2500	Complies
5310	9.67	0.0093	23.98	0.2500	Complies
5510	9.84	0.0096	23.98	0.2500	Complies
5550	9.87	0.0097	23.98	0.2500	Complies
5670	9.93	0.0098	23.98	0.2500	Complies

Test Mode	IEEE 802.11n (HT40)_Total	Tested Date	2022/8/17
-----------	---------------------------	-------------	-----------

Frequency (MHz)	Conducted Power (dBm)	Conducted Power (W)	Max. Limit (dBm)	Max. Limit (W)	Result
5190	12.52	0.0179	23.98	0.2500	Complies
5230	12.67	0.0185	23.98	0.2500	Complies
5270	12.06	0.0161	23.98	0.2500	Complies
5310	12.12	0.0163	23.98	0.2500	Complies
5510	12.80	0.0191	23.98	0.2500	Complies
5550	12.81	0.0191	23.98	0.2500	Complies
5670	12.83	0.0192	23.98	0.2500	Complies

Test Mode	IEEE 802.11ac (VHT20)_Main Antenna	Tested Date	2022/8/17
-----------	------------------------------------	-------------	-----------

Frequency (MHz)	Conducted Power (dBm)	Conducted Power (W)	Max. Limit (dBm)	Max. Limit (W)	Result
5180	8.79	0.0076	23.98	0.2500	Complies
5200	8.61	0.0073	23.98	0.2500	Complies
5240	9.05	0.0080	23.98	0.2500	Complies
5260	9.21	0.0083	23.98	0.2500	Complies
5300	9.24	0.0084	23.98	0.2500	Complies
5320	9.12	0.0082	23.98	0.2500	Complies
5500	9.27	0.0085	23.98	0.2500	Complies
5580	9.34	0.0086	23.98	0.2500	Complies
5700	8.94	0.0078	23.98	0.2500	Complies

Test Mode	IEEE 802.11ac (VHT20)_Aux Antenna	Tested Date	2022/8/17
-----------	-----------------------------------	-------------	-----------

Frequency (MHz)	Conducted Power (dBm)	Conducted Power (W)	Max. Limit (dBm)	Max. Limit (W)	Result
5180	9.67	0.0093	23.98	0.2500	Complies
5200	9.51	0.0089	23.98	0.2500	Complies
5240	9.77	0.0095	23.98	0.2500	Complies
5260	9.94	0.0099	23.98	0.2500	Complies
5300	9.84	0.0096	23.98	0.2500	Complies
5320	9.90	0.0098	23.98	0.2500	Complies
5500	9.87	0.0097	23.98	0.2500	Complies
5580	9.87	0.0097	23.98	0.2500	Complies
5700	9.95	0.0099	23.98	0.2500	Complies

Test Mode	IEEE 802.11ac (VHT20)_Total	Tested Date	2022/8/17
-----------	-----------------------------	-------------	-----------

Frequency (MHz)	Conducted Power (dBm)	Conducted Power (W)	Max. Limit (dBm)	Max. Limit (W)	Result
5180	12.26	0.0168	23.98	0.2500	Complies
5200	12.09	0.0162	23.98	0.2500	Complies
5240	12.44	0.0175	23.98	0.2500	Complies
5260	12.60	0.0182	23.98	0.2500	Complies
5300	12.56	0.0180	23.98	0.2500	Complies
5320	12.54	0.0179	23.98	0.2500	Complies
5500	12.59	0.0182	23.98	0.2500	Complies
5580	12.62	0.0183	23.98	0.2500	Complies
5700	12.48	0.0177	23.98	0.2500	Complies

Test Mode	IEEE 802.11ac (VHT40)_Main Antenna	Tested Date	2022/8/17
-----------	------------------------------------	-------------	-----------

Frequency (MHz)	Conducted Power (dBm)	Conducted Power (W)	Max. Limit (dBm)	Max. Limit (W)	Result
5190	9.12	0.0082	23.98	0.2500	Complies
5230	9.47	0.0089	23.98	0.2500	Complies
5270	9.84	0.0096	23.98	0.2500	Complies
5310	9.77	0.0095	23.98	0.2500	Complies
5510	9.76	0.0095	23.98	0.2500	Complies
5550	9.73	0.0094	23.98	0.2500	Complies
5670	9.77	0.0095	23.98	0.2500	Complies

Test Mode	IEEE 802.11ac (VHT40)_Aux Antenna	Tested Date	2022/8/17
-----------	-----------------------------------	-------------	-----------

Frequency (MHz)	Conducted Power (dBm)	Conducted Power (W)	Max. Limit (dBm)	Max. Limit (W)	Result
5190	9.94	0.0099	23.98	0.2500	Complies
5230	9.92	0.0098	23.98	0.2500	Complies
5270	9.94	0.0099	23.98	0.2500	Complies
5310	9.88	0.0097	23.98	0.2500	Complies
5510	9.85	0.0097	23.98	0.2500	Complies
5550	9.90	0.0098	23.98	0.2500	Complies
5670	9.97	0.0099	23.98	0.2500	Complies

Test Mode	IEEE 802.11ac (VHT40)_Total	Tested Date	2022/8/17
-----------	-----------------------------	-------------	-----------

Frequency (MHz)	Conducted Power (dBm)	Conducted Power (W)	Max. Limit (dBm)	Max. Limit (W)	Result
5190	12.56	0.0180	23.98	0.2500	Complies
5230	12.71	0.0187	23.98	0.2500	Complies
5270	12.90	0.0195	23.98	0.2500	Complies
5310	12.84	0.0192	23.98	0.2500	Complies
5510	12.82	0.0191	23.98	0.2500	Complies
5550	12.83	0.0192	23.98	0.2500	Complies
5670	12.88	0.0194	23.98	0.2500	Complies

Test Mode	IEEE 802.11ac (VHT80)_Main Antenna	Tested Date	2022/8/17
-----------	------------------------------------	-------------	-----------

Frequency (MHz)	Conducted Power (dBm)	Conducted Power (W)	Max. Limit (dBm)	Max. Limit (W)	Result
5210	9.75	0.0094	23.98	0.2500	Complies
5290	9.81	0.0096	23.98	0.2500	Complies
5530	9.84	0.0096	23.98	0.2500	Complies

Test Mode	IEEE 802.11ac (VHT80)_Aux Antenna	Tested Date	2022/8/17
-----------	-----------------------------------	-------------	-----------

Frequency (MHz)	Conducted Power (dBm)	Conducted Power (W)	Max. Limit (dBm)	Max. Limit (W)	Result
5210	9.89	0.0097	23.98	0.2500	Complies
5290	9.97	0.0099	23.98	0.2500	Complies
5530	9.98	0.0100	23.98	0.2500	Complies

Test Mode	IEEE 802.11ac (VHT80)_Total	Tested Date	2022/8/17
-----------	-----------------------------	-------------	-----------

Frequency (MHz)	Conducted Power (dBm)	Conducted Power (W)	Max. Limit (dBm)	Max. Limit (W)	Result
5210	12.83	0.0192	23.98	0.2500	Complies
5290	12.90	0.0195	23.98	0.2500	Complies
5530	12.92	0.0196	23.98	0.2500	Complies

For Straddle Channel:

Test Mode	IEEE 802.11a_Main Antenna	Tested Date	2022/8/17
-----------	---------------------------	-------------	-----------

Frequency (MHz)	Conducted Power (dBm)	Conducted Power (W)	Max. Limit (dBm)	Max. Limit (W)	Result
5720	8.55	0.0072	23.98	0.2500	Complies
5720	1.25	0.0013	23.98	0.2500	Complies

Test Mode	IEEE 802.11a_Aux Antenna	Tested Date	2022/8/17
-----------	--------------------------	-------------	-----------

Frequency (MHz)	Conducted Power (dBm)	Conducted Power (W)	Max. Limit (dBm)	Max. Limit (W)	Result
5720	9.79	0.0095	23.98	0.2500	Complies
5720	2.36	0.0017	23.98	0.2500	Complies

Test Mode	IEEE 802.11a_Total	Tested Date	2022/8/17
-----------	--------------------	-------------	-----------

Frequency (MHz)	Conducted Power (dBm)	Conducted Power (W)	Max. Limit (dBm)	Max. Limit (W)	Result
5720	12.22	0.0167	23.98	0.2500	Complies
5720	4.85	0.0031	23.98	0.2500	Complies

Test Mode	IEEE 802.11n (HT20)_Main Antenna	Tested Date	2022/8/17
-----------	----------------------------------	-------------	-----------

Frequency (MHz)	Conducted Power (dBm)	Conducted Power (W)	Max. Limit (dBm)	Max. Limit (W)	Result
5720	8.68	0.0074	23.98	0.2500	Complies
5720	-4.77	0.0003	23.98	0.2500	Complies

Test Mode	IEEE 802.11n (HT20)_Aux Antenna	Tested Date	2022/8/17
-----------	---------------------------------	-------------	-----------

Frequency (MHz)	Conducted Power (dBm)	Conducted Power (W)	Max. Limit (dBm)	Max. Limit (W)	Result
5720	9.37	0.0086	23.98	0.2500	Complies
5720	-4.52	0.0004	23.98	0.2500	Complies

Test Mode	IEEE 802.11n (HT20)_Total	Tested Date	2022/8/17
-----------	---------------------------	-------------	-----------

Frequency (MHz)	Conducted Power (dBm)	Conducted Power (W)	Max. Limit (dBm)	Max. Limit (W)	Result
5720	12.05	0.0160	23.98	0.2500	Complies
5720	-1.63	0.0007	23.98	0.2500	Complies

Test Mode	IEEE 802.11n (HT40)_Main Antenna	Tested Date	2022/8/17
-----------	----------------------------------	-------------	-----------

Frequency (MHz)	Conducted Power (dBm)	Conducted Power (W)	Max. Limit (dBm)	Max. Limit (W)	Result
5710	8.58	0.0072	23.98	0.2500	Complies
5710	-1.41	0.0007	23.98	0.2500	Complies

Test Mode	IEEE 802.11n (HT40)_Aux Antenna	Tested Date	2022/8/17
-----------	---------------------------------	-------------	-----------

Frequency (MHz)	Conducted Power (dBm)	Conducted Power (W)	Max. Limit (dBm)	Max. Limit (W)	Result
5710	9.18	0.0083	23.98	0.2500	Complies
5710	-1.02	0.0008	23.98	0.2500	Complies

Test Mode	IEEE 802.11n (HT40)_Total	Tested Date	2022/8/17
-----------	---------------------------	-------------	-----------

Frequency (MHz)	Conducted Power (dBm)	Conducted Power (W)	Max. Limit (dBm)	Max. Limit (W)	Result
5710	11.90	0.0155	23.98	0.2500	Complies
5710	1.80	0.0015	23.98	0.2500	Complies

Test Mode	IEEE 802.11ac (VHT20)_Main Antenna	Tested Date	2022/8/17
-----------	------------------------------------	-------------	-----------

Frequency (MHz)	Conducted Power (dBm)	Conducted Power (W)	Max. Limit (dBm)	Max. Limit (W)	Result
5720	8.24	0.0067	23.98	0.2500	Complies
5720	1.47	0.0014	23.98	0.2500	Complies

Test Mode	IEEE 802.11ac (VHT20)_Aux Antenna	Tested Date	2022/8/17
-----------	-----------------------------------	-------------	-----------

Frequency (MHz)	Conducted Power (dBm)	Conducted Power (W)	Max. Limit (dBm)	Max. Limit (W)	Result
5720	9.43	0.0088	23.98	0.2500	Complies
5720	2.54	0.0018	23.98	0.2500	Complies

Test Mode	IEEE 802.11ac (VHT20)_Total	Tested Date	2022/8/17
-----------	-----------------------------	-------------	-----------

Frequency (MHz)	Conducted Power (dBm)	Conducted Power (W)	Max. Limit (dBm)	Max. Limit (W)	Result
5720	11.89	0.0154	23.98	0.2500	Complies
5720	5.05	0.0032	23.98	0.2500	Complies

Test Mode	IEEE 802.11ac (VHT40)_Main Antenna	Tested Date	2022/8/17
-----------	------------------------------------	-------------	-----------

Frequency (MHz)	Conducted Power (dBm)	Conducted Power (W)	Max. Limit (dBm)	Max. Limit (W)	Result
5710	8.63	0.0073	23.98	0.2500	Complies
5710	-1.30	0.0007	23.98	0.2500	Complies

Test Mode	IEEE 802.11ac (VHT40)_Aux Antenna	Tested Date	2022/8/17
-----------	-----------------------------------	-------------	-----------

Frequency (MHz)	Conducted Power (dBm)	Conducted Power (W)	Max. Limit (dBm)	Max. Limit (W)	Result
5710	9.23	0.0084	23.98	0.2500	Complies
5710	-0.96	0.0008	23.98	0.2500	Complies

Test Mode	IEEE 802.11ac (VHT40)_Total	Tested Date	2022/8/17
-----------	-----------------------------	-------------	-----------

Frequency (MHz)	Conducted Power (dBm)	Conducted Power (W)	Max. Limit (dBm)	Max. Limit (W)	Result
5710	11.95	0.0157	23.98	0.2500	Complies
5710	1.88	0.0015	23.98	0.2500	Complies

Test Mode	IEEE 802.11ac (VHT80)_Main Antenna	Tested Date	2022/8/17
-----------	------------------------------------	-------------	-----------

Frequency (MHz)	Conducted Power (dBm)	Conducted Power (W)	Max. Limit (dBm)	Max. Limit (W)	Result
5690	8.72	0.0074	23.98	0.2500	Complies
5690	-4.61	0.0003	23.98	0.2500	Complies

Test Mode	IEEE 802.11ac (VHT80)_Aux Antenna	Tested Date	2022/8/17
-----------	-----------------------------------	-------------	-----------

Frequency (MHz)	Conducted Power (dBm)	Conducted Power (W)	Max. Limit (dBm)	Max. Limit (W)	Result
5690	9.68	0.0093	23.98	0.2500	Complies
5690	-4.11	0.0004	23.98	0.2500	Complies

Test Mode	IEEE 802.11ac (VHT80)_Total	Tested Date	2022/8/17
-----------	-----------------------------	-------------	-----------

Frequency (MHz)	Conducted Power (dBm)	Conducted Power (W)	Max. Limit (dBm)	Max. Limit (W)	Result
5690	12.24	0.0167	23.98	0.2500	Complies
5690	-1.34	0.0007	23.98	0.2500	Complies

APPENDIX F POWER SPECTRAL DENSITY

Test Mode | IEEE 802.11a_Main Antenna

Test Frequency (MHz)	Power Density (dBm/MHz)	Duty Factor (dB)	Calculated Power Density (dBm/MHz)	Maximum Limit (dBm/MHz)	Result
5180	2.45	1.44	3.89	17.00	Pass
5200	2.17	1.44	3.61	17.00	Pass
5240	1.59	1.44	3.03	17.00	Pass

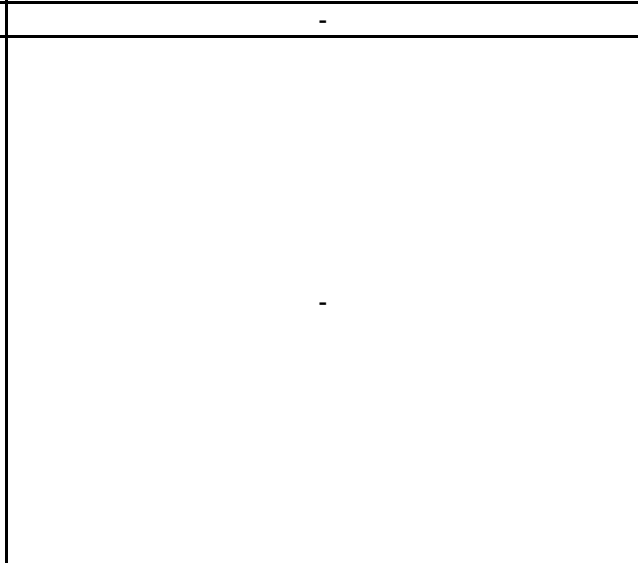
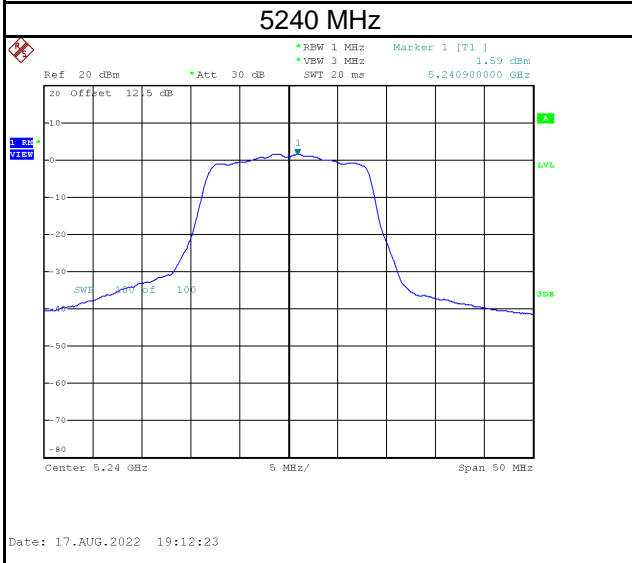
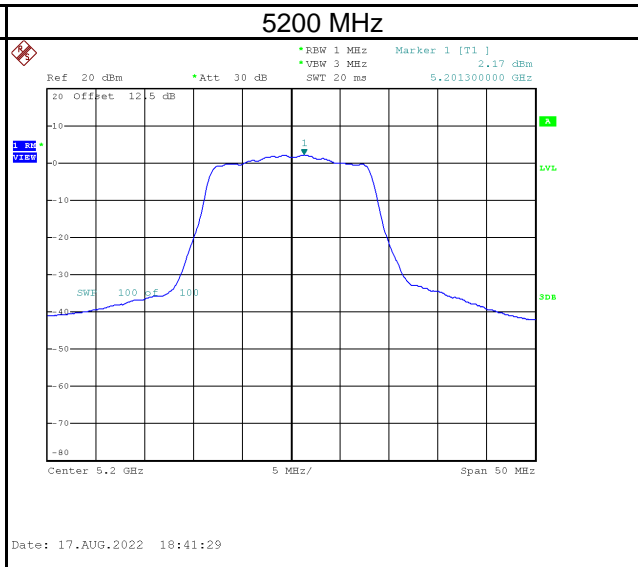
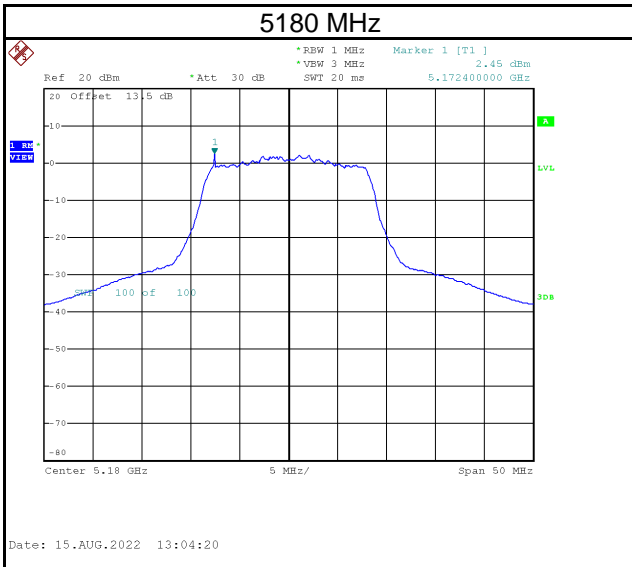

Test Frequency (MHz)	Power Density (dBm/MHz)	Duty Factor (dB)	Calculated Power Density (dBm/MHz)	Maximum Limit (dBm/MHz)	Result
5260	3.53	1.44	4.97	11.00	Pass
5300	1.69	1.44	3.13	11.00	Pass
5320	0.22	1.44	1.66	11.00	Pass

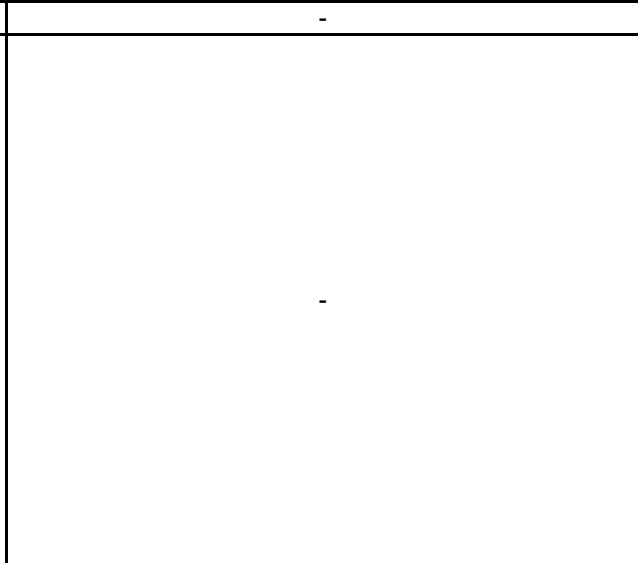
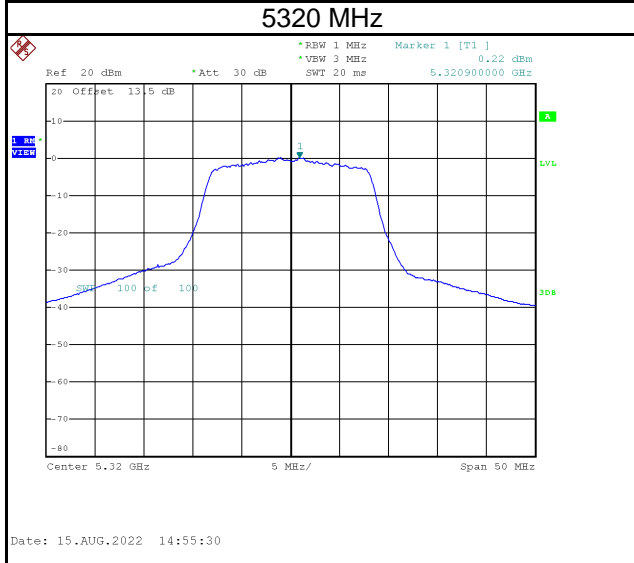
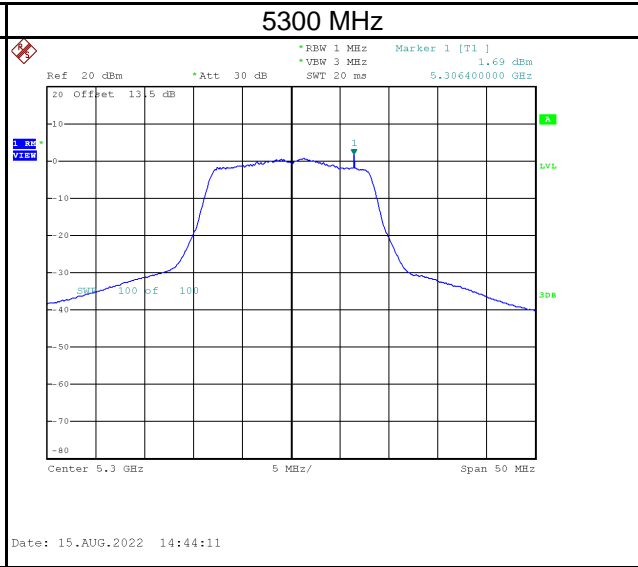
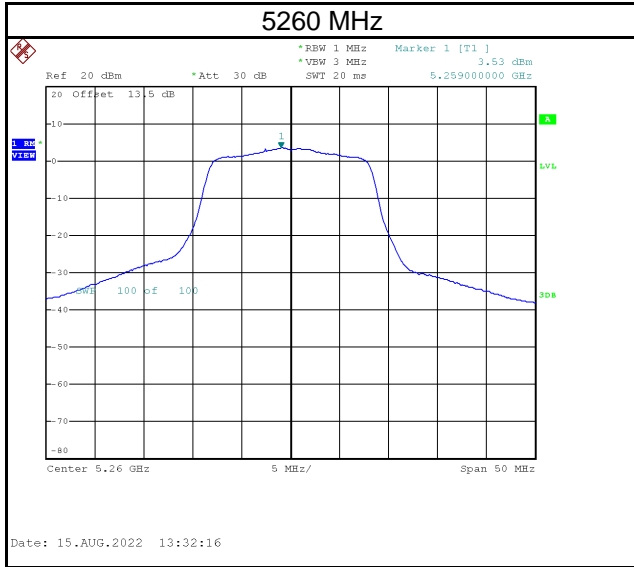

Test Frequency (MHz)	Power Density (dBm/MHz)	Duty Factor (dB)	Calculated Power Density (dBm/MHz)	Maximum Limit (dBm/MHz)	Result
5500	0.57	1.44	2.01	11.00	Pass
5580	3.69	1.44	5.13	11.00	Pass
5700	3.00	1.44	4.44	11.00	Pass

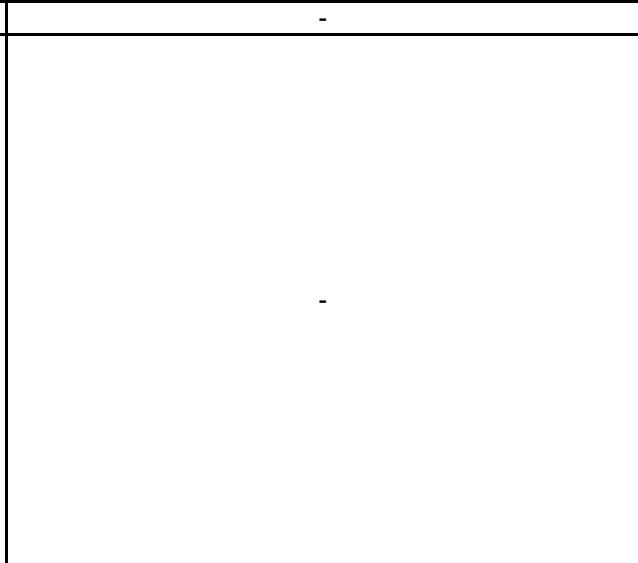
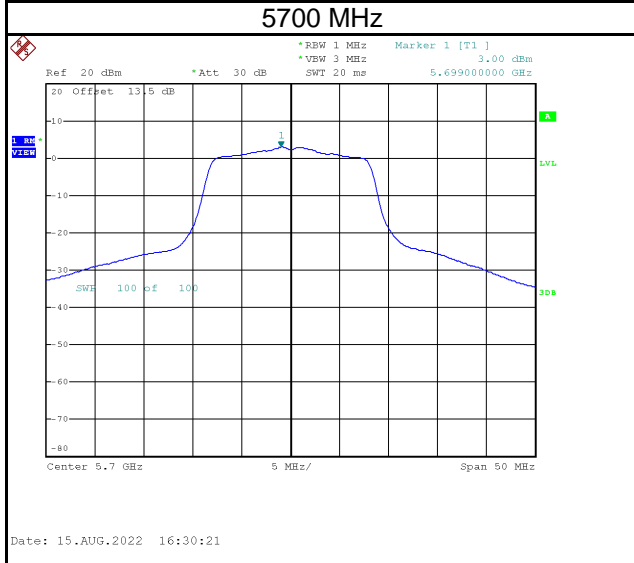
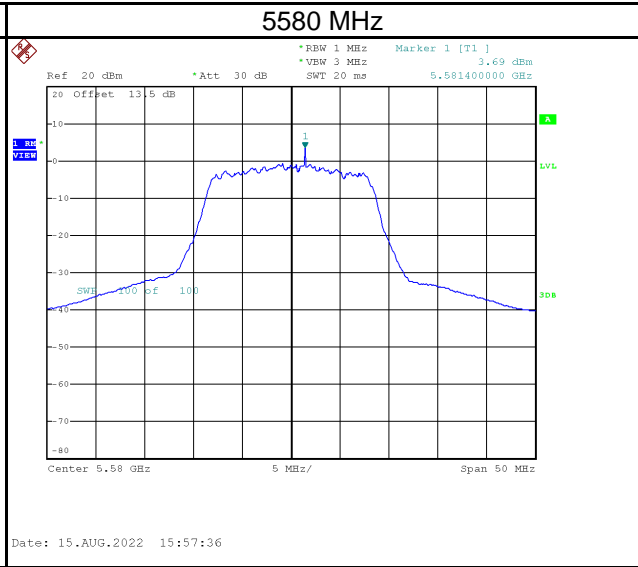
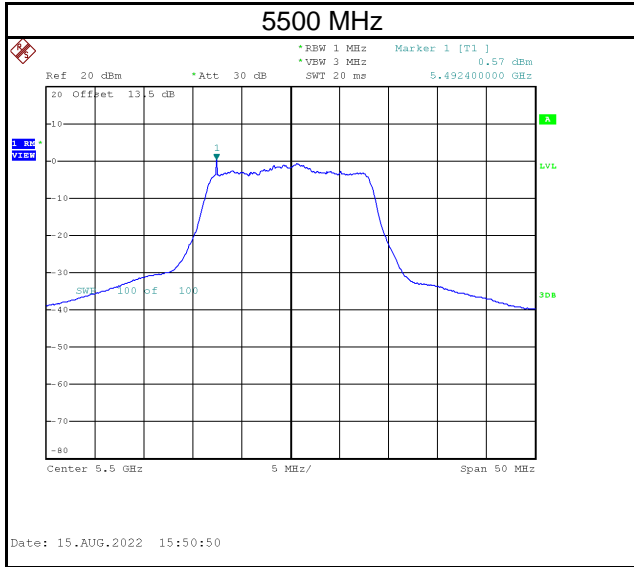

Test Mode	IEEE 802.11a_Aux Antenna
-----------	--------------------------

Test Frequency (MHz)	Power Density (dBm/MHz)	Duty Factor (dB)	Calculated Power Density (dBm/MHz)	Maximum Limit (dBm/MHz)	Result
5180	2.57	1.44	4.01	17.00	Pass
5200	2.71	1.44	4.15	17.00	Pass
5240	1.73	1.44	3.17	17.00	Pass

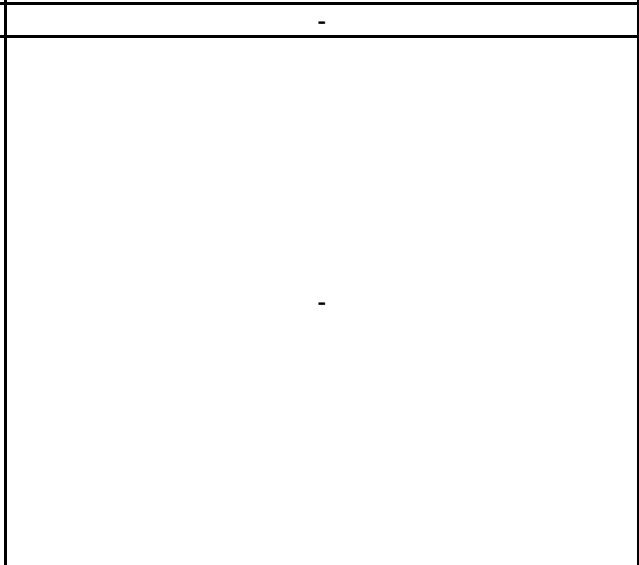
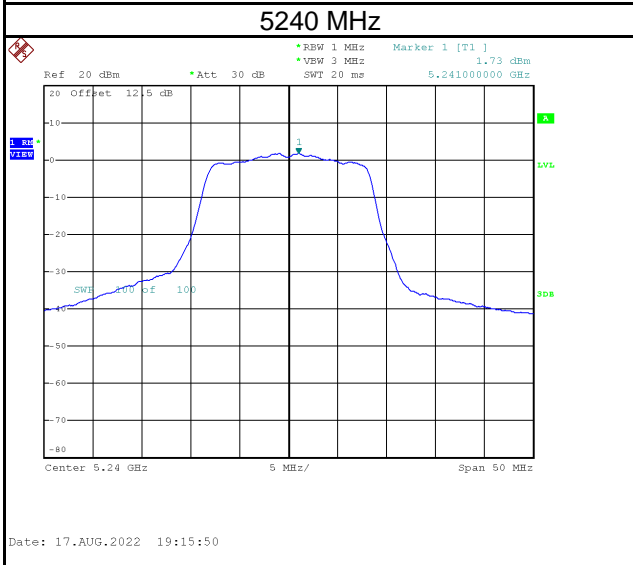
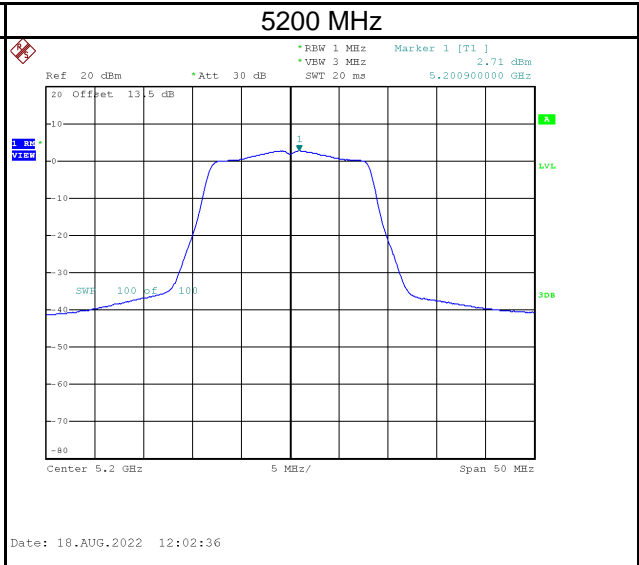
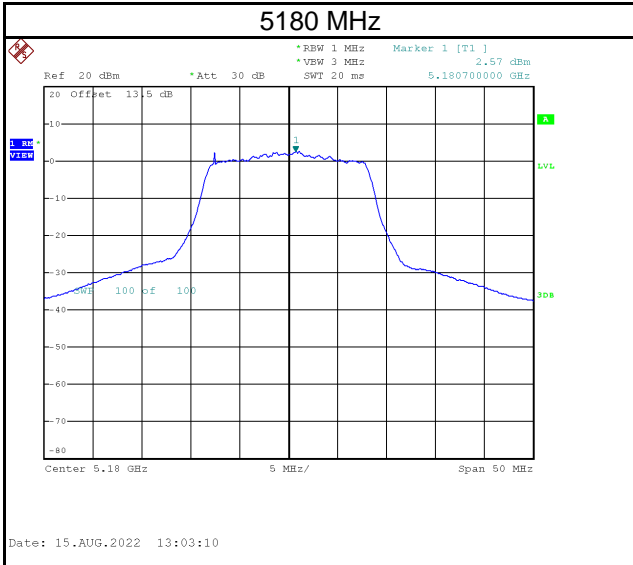

Test Frequency (MHz)	Power Density (dBm/MHz)	Duty Factor (dB)	Calculated Power Density (dBm/MHz)	Maximum Limit (dBm/MHz)	Result
5260	4.01	1.44	5.45	11.00	Pass
5300	2.85	1.44	4.29	11.00	Pass
5320	1.43	1.44	2.87	11.00	Pass

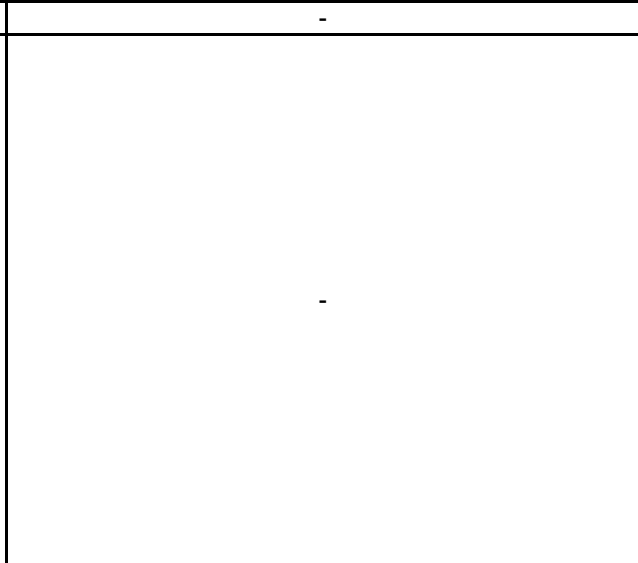
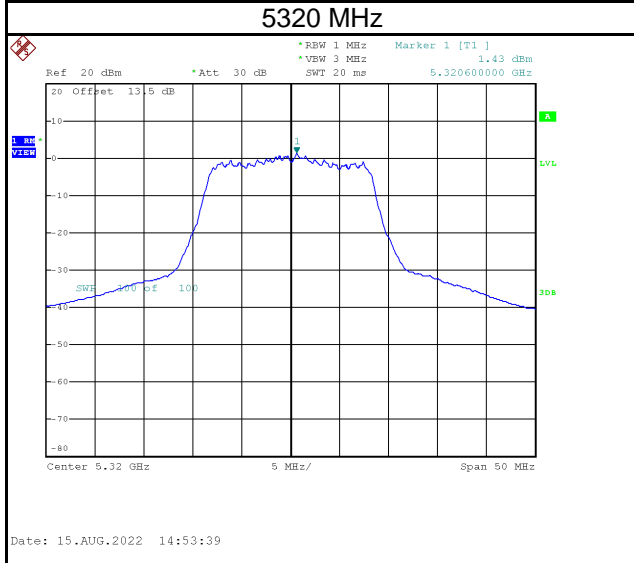
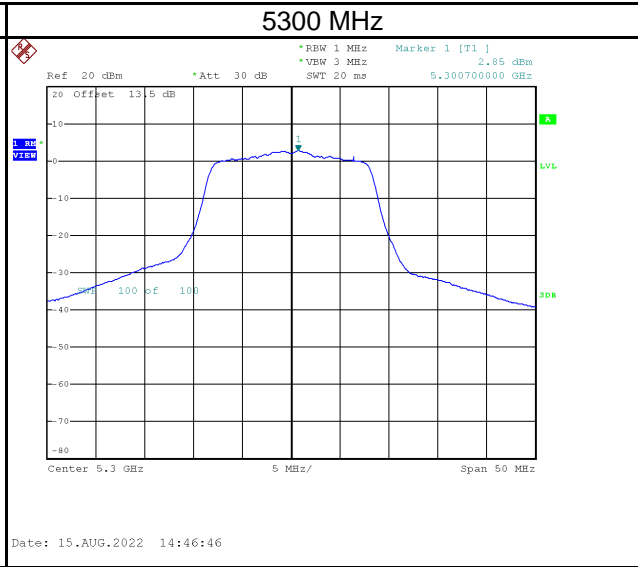
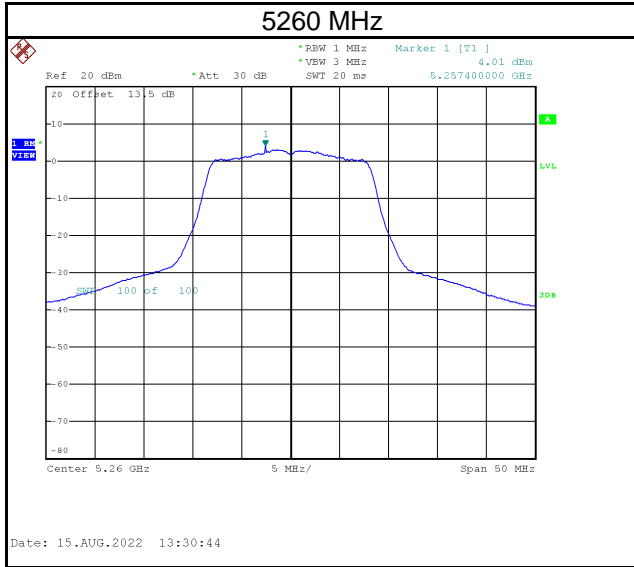

Test Frequency (MHz)	Power Density (dBm/MHz)	Duty Factor (dB)	Calculated Power Density (dBm/MHz)	Maximum Limit (dBm/MHz)	Result
5500	2.34	1.44	3.78	11.00	Pass
5580	5.14	1.44	6.58	11.00	Pass
5700	4.49	1.44	5.93	11.00	Pass

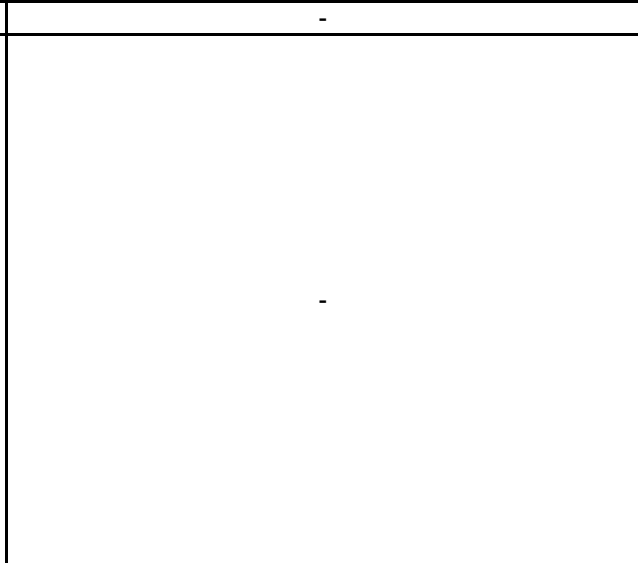
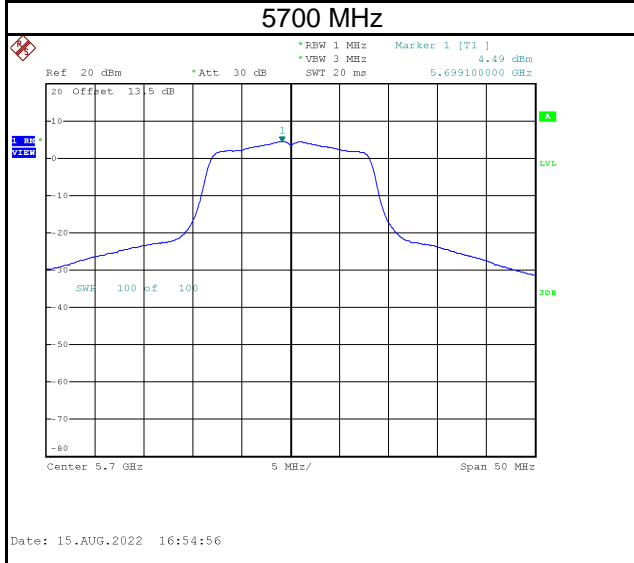
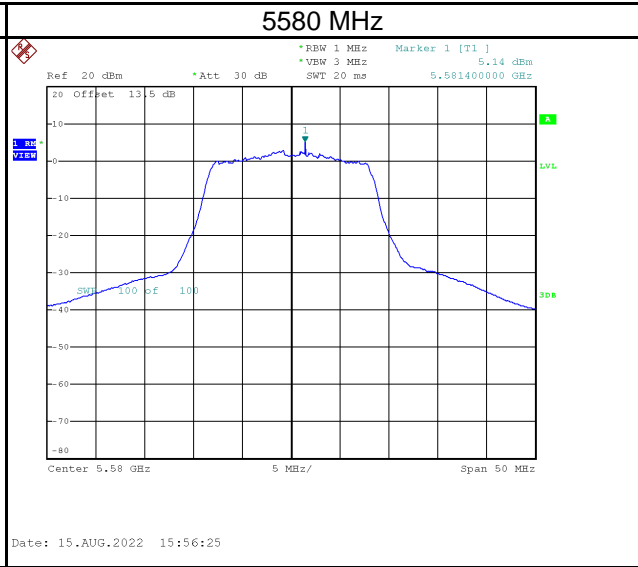
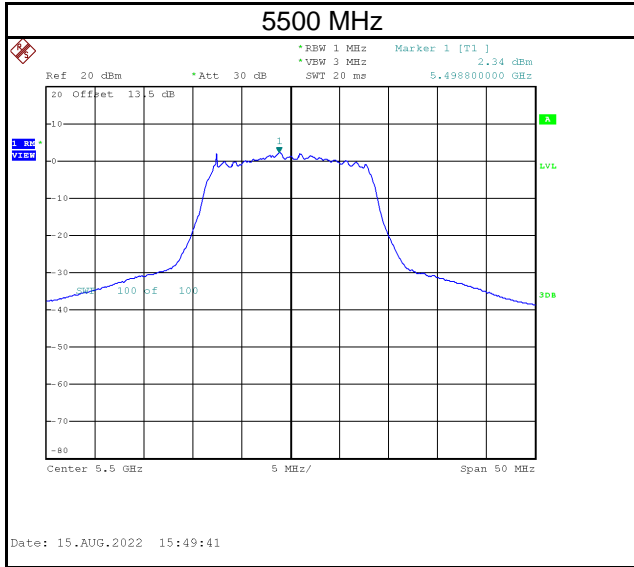

Test Mode	IEEE 802.11a_Total
-----------	--------------------

Test Frequency (MHz)	Calculated Power Density (dBm/MHz)	Maximum Limit (dBm/MHz)	Result
5180	6.97	17.00	Pass
5200	6.90	17.00	Pass
5240	6.12	17.00	Pass

Test Frequency (MHz)	Calculated Power Density (dBm/MHz)	Maximum Limit (dBm/MHz)	Result
5260	8.23	11.00	Pass
5300	6.76	11.00	Pass
5320	5.32	11.00	Pass

Test Frequency (MHz)	Calculated Power Density (dBm/MHz)	Maximum Limit (dBm/MHz)	Result
5500	6.00	11.00	Pass
5580	8.93	11.00	Pass
5700	8.26	11.00	Pass

Test Mode	IEEE 802.11ac (VHT20)_Main Antenna
-----------	------------------------------------

Test Frequency (MHz)	Power Density (dBm/MHz)	Duty Factor (dB)	Calculated Power Density (dBm/MHz)	Maximum Limit (dBm/MHz)	Result
5180	0.56	0.44	1.00	17.00	Pass
5200	0.52	0.44	0.96	17.00	Pass
5240	-0.02	0.44	0.42	17.00	Pass

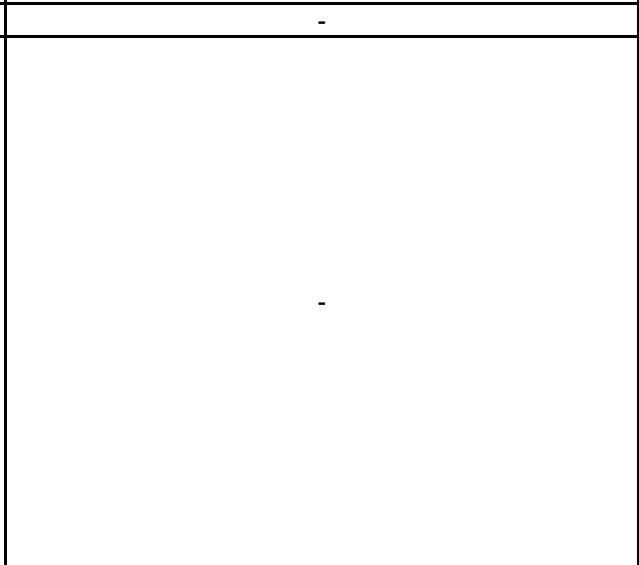
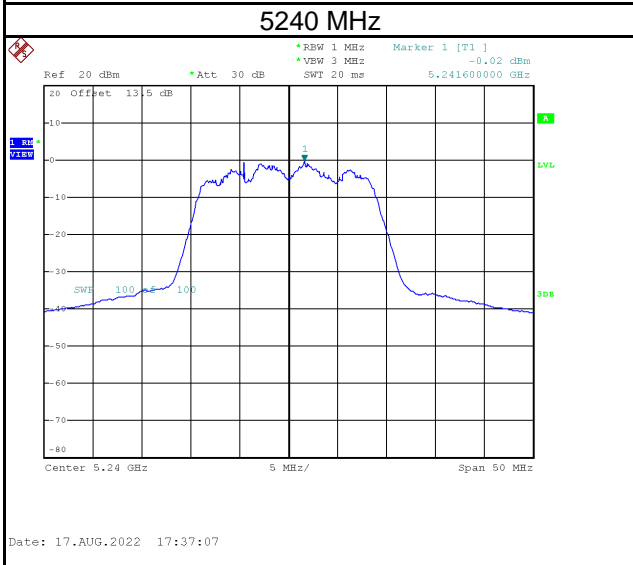
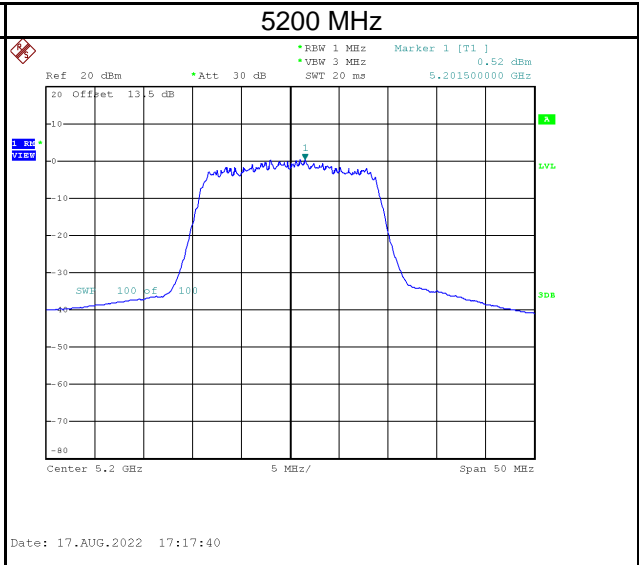
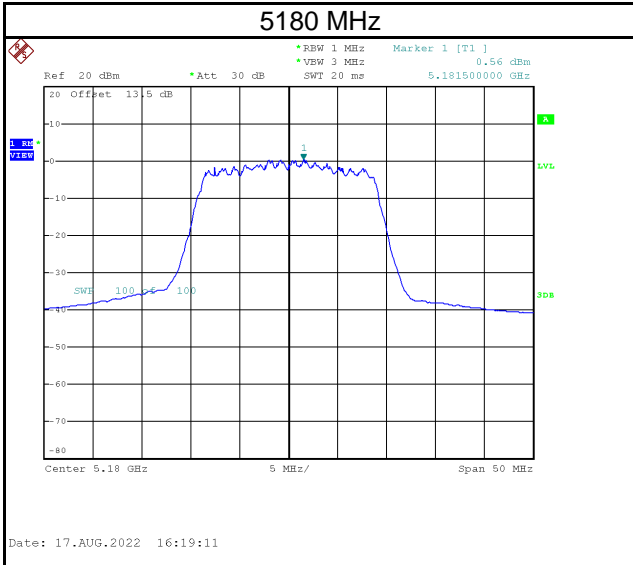

Test Frequency (MHz)	Power Density (dBm/MHz)	Duty Factor (dB)	Calculated Power Density (dBm/MHz)	Maximum Limit (dBm/MHz)	Result
5260	0.57	0.44	1.01	11.00	Pass
5300	-3.64	0.44	-3.20	11.00	Pass
5320	-1.32	0.44	-0.88	11.00	Pass

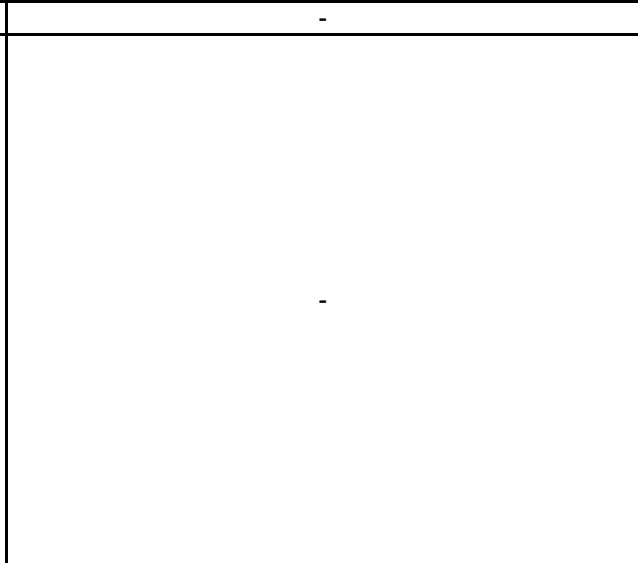
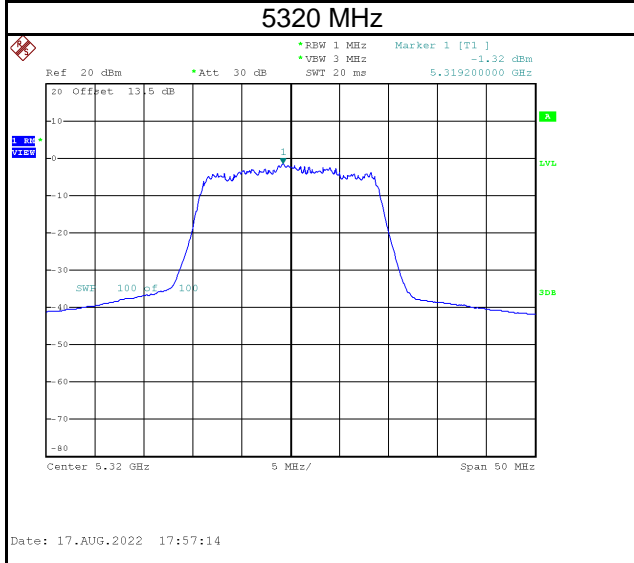
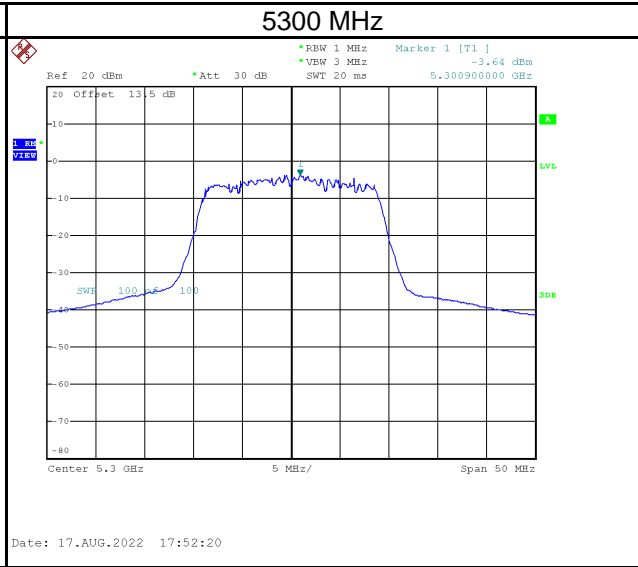
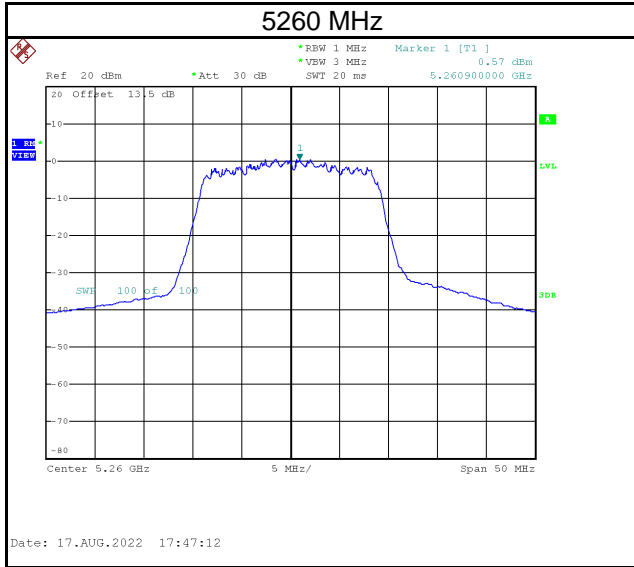

Test Frequency (MHz)	Power Density (dBm/MHz)	Duty Factor (dB)	Calculated Power Density (dBm/MHz)	Maximum Limit (dBm/MHz)	Result
5500	-1.12	0.44	-0.68	11.00	Pass
5580	2.93	0.44	3.37	11.00	Pass
5700	-3.12	0.44	-2.68	11.00	Pass

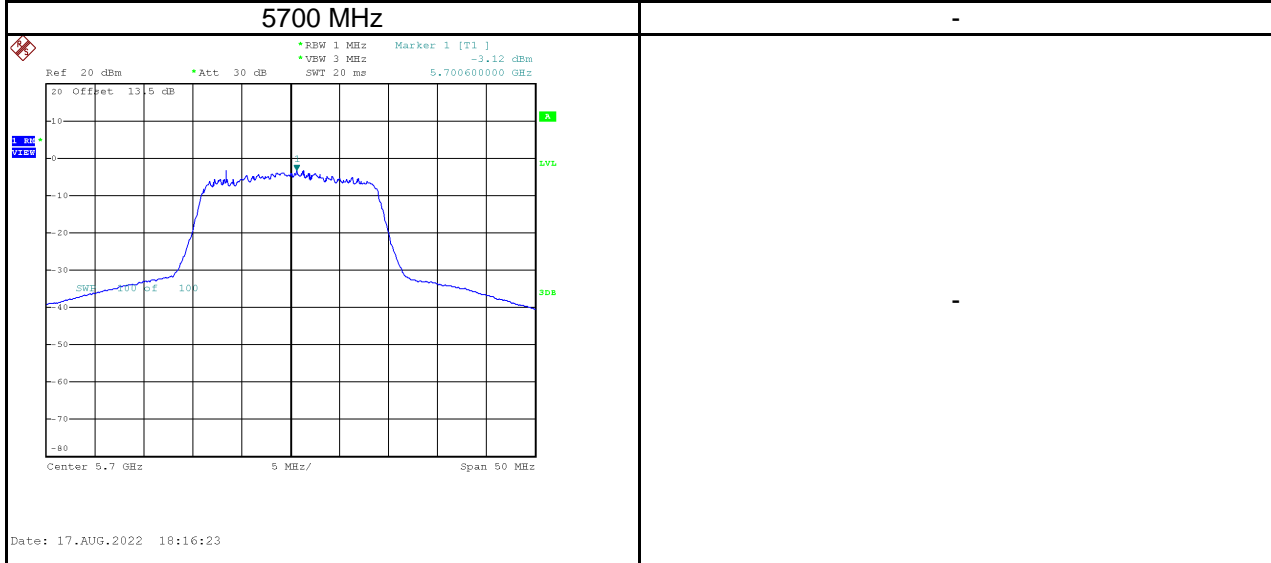
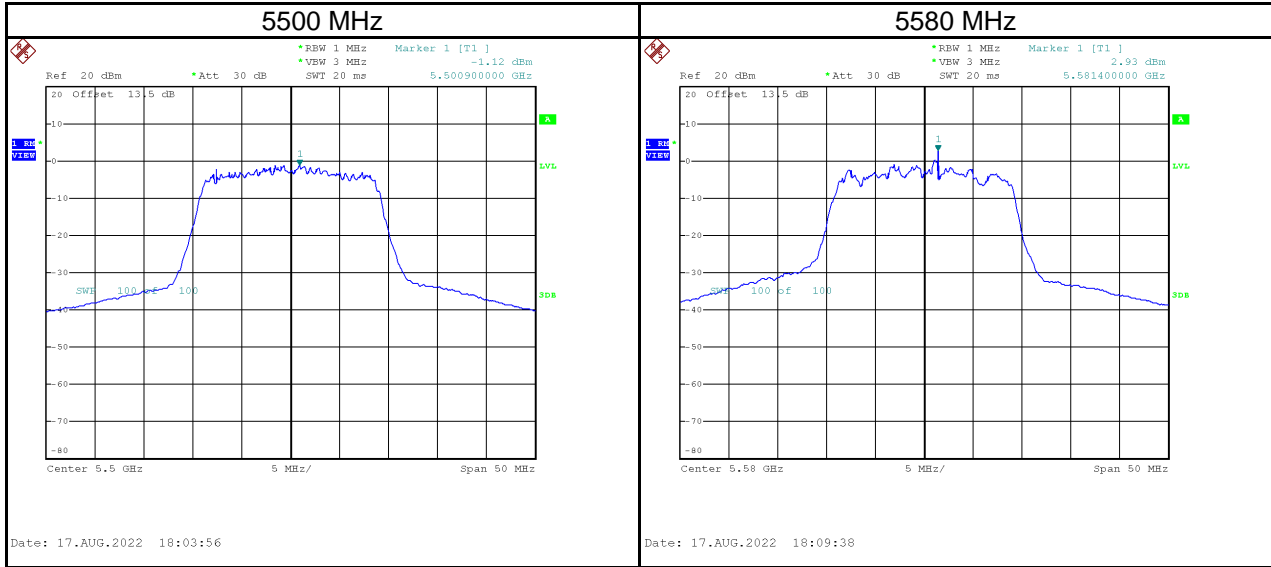

Test Mode	IEEE 802.11ac (VHT20)_Aux Antenna
-----------	-----------------------------------

Test Frequency (MHz)	Power Density (dBm/MHz)	Duty Factor (dB)	Calculated Power Density (dBm/MHz)	Maximum Limit (dBm/MHz)	Result
5180	0.84	0.44	1.28	17.00	Pass
5200	1.41	0.44	1.85	17.00	Pass
5240	0.04	0.44	0.48	17.00	Pass

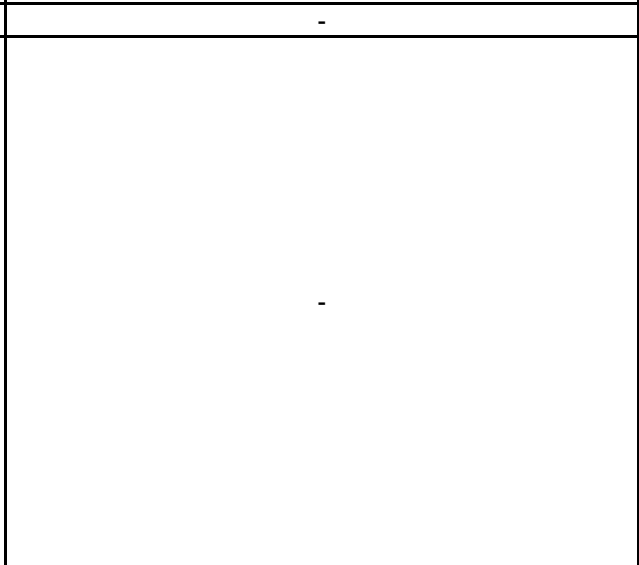
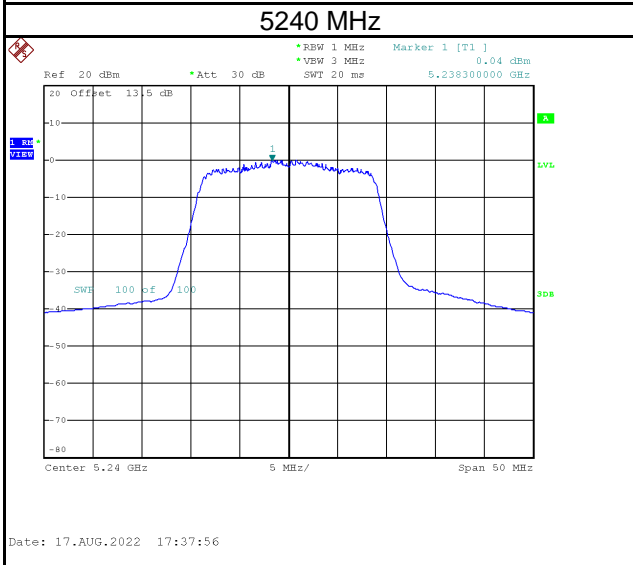
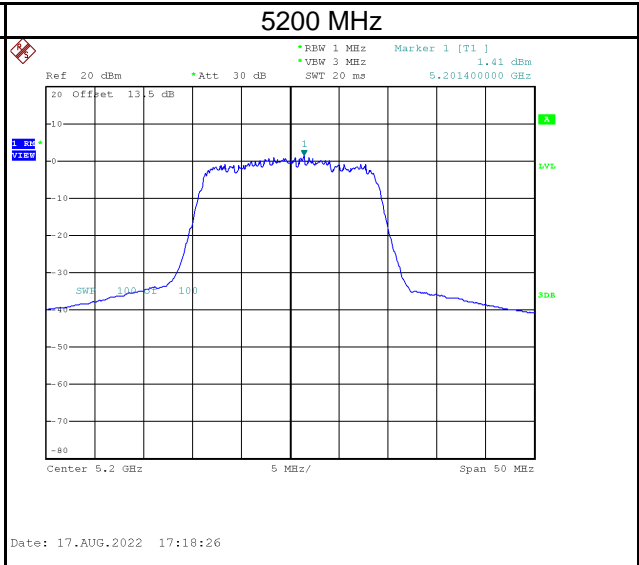
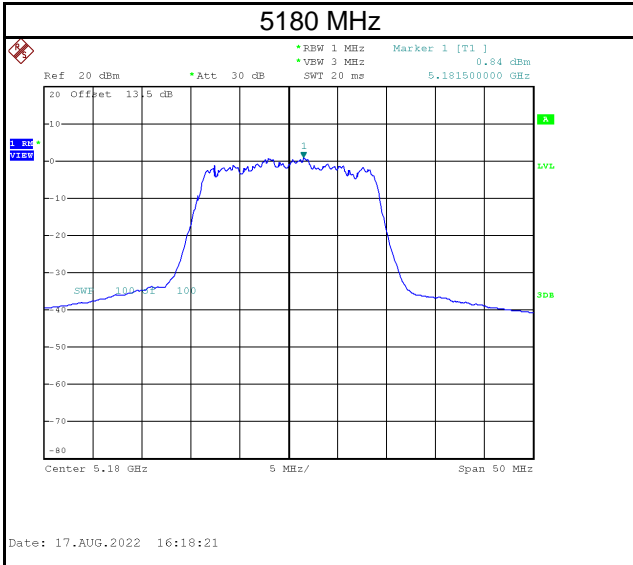

Test Frequency (MHz)	Power Density (dBm/MHz)	Duty Factor (dB)	Calculated Power Density (dBm/MHz)	Maximum Limit (dBm/MHz)	Result
5260	1.04	0.44	1.48	11.00	Pass
5300	1.72	0.44	2.16	11.00	Pass
5320	0.11	0.44	0.55	11.00	Pass

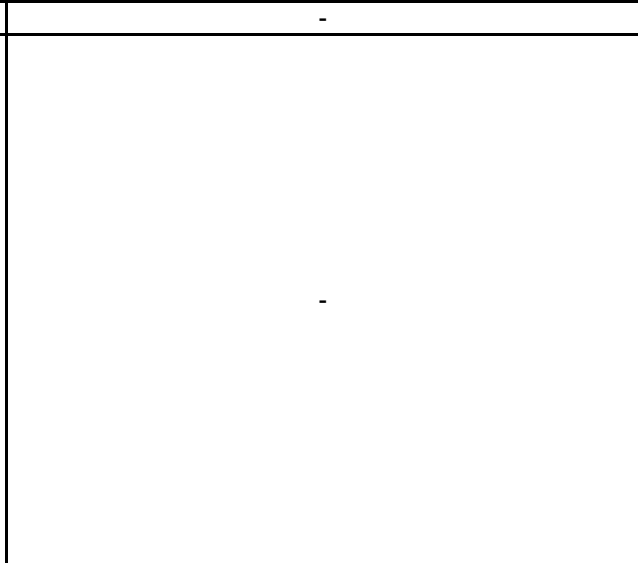
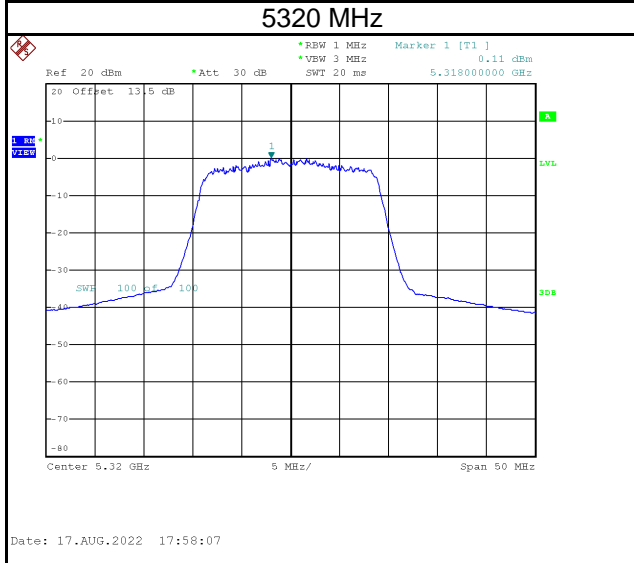
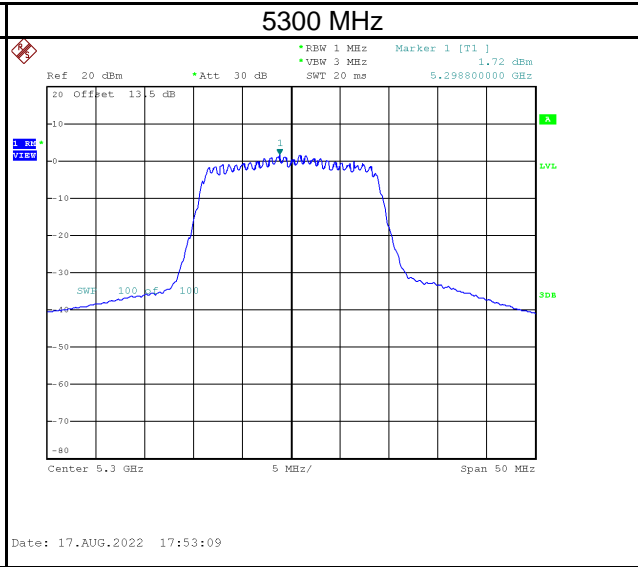
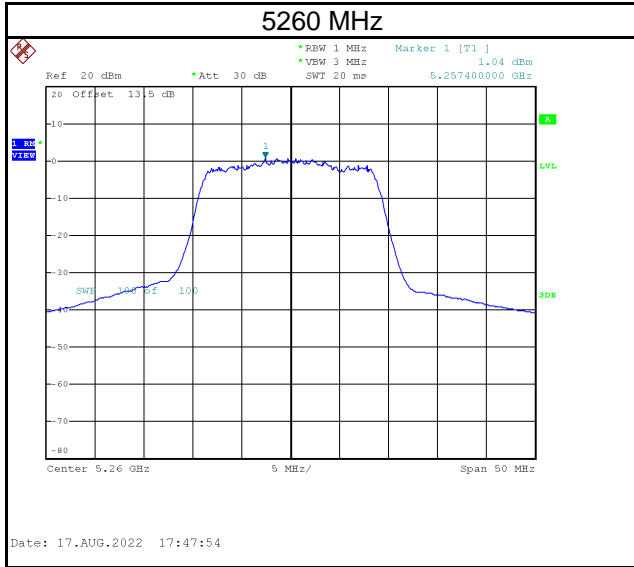

Test Frequency (MHz)	Power Density (dBm/MHz)	Duty Factor (dB)	Calculated Power Density (dBm/MHz)	Maximum Limit (dBm/MHz)	Result
5500	0.12	0.44	0.56	11.00	Pass
5580	2.34	0.44	2.78	11.00	Pass
5700	-1.14	0.44	-0.70	11.00	Pass

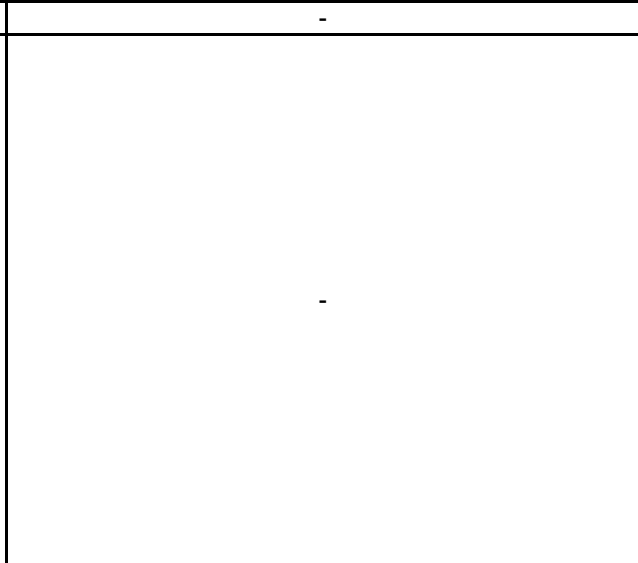
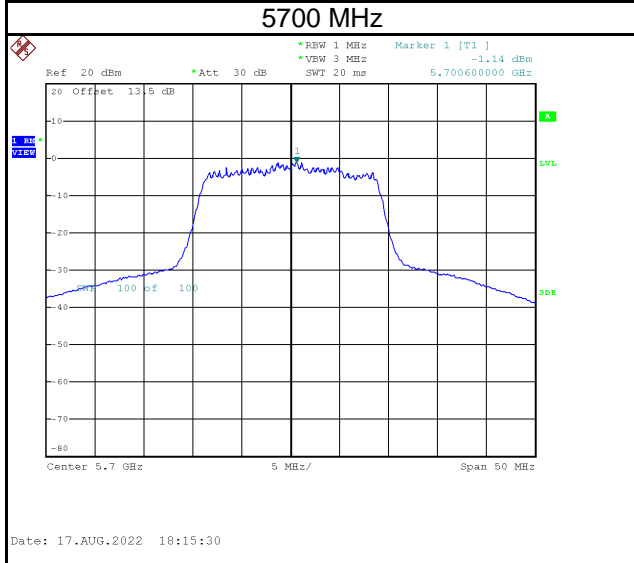
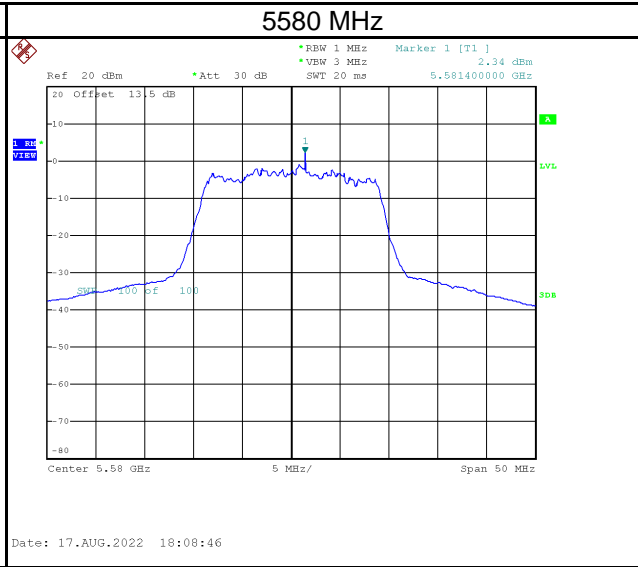
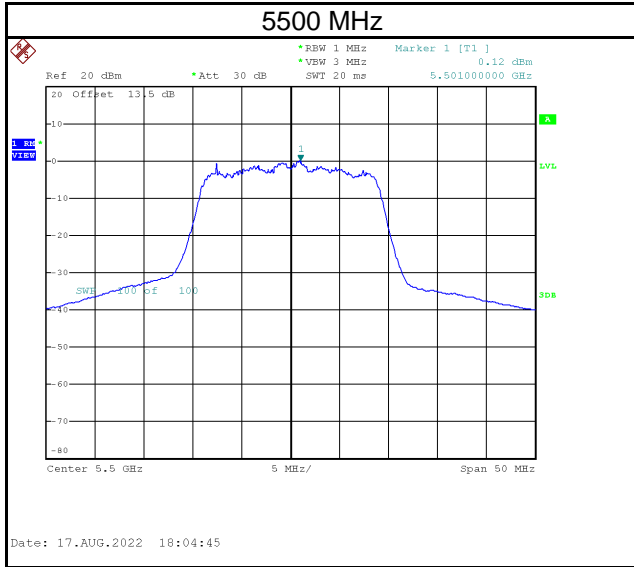

Test Mode	IEEE 802.11ac (VHT20)_Total
-----------	-----------------------------

Test Frequency (MHz)	Calculated Power Density (dBm/MHz)	Maximum Limit (dBm/MHz)	Result
5180	4.15	17.00	Pass
5200	4.44	17.00	Pass
5240	3.46	17.00	Pass

Test Frequency (MHz)	Calculated Power Density (dBm/MHz)	Maximum Limit (dBm/MHz)	Result
5260	4.26	11.00	Pass
5300	3.27	11.00	Pass
5320	2.90	11.00	Pass

Test Frequency (MHz)	Calculated Power Density (dBm/MHz)	Maximum Limit (dBm/MHz)	Result
5500	3.00	11.00	Pass
5580	6.10	11.00	Pass
5700	1.43	11.00	Pass

Test Mode	IEEE 802.11ac (VHT40)_Main Antenna
-----------	------------------------------------

Test Frequency (MHz)	Power Density (dBm/MHz)	Duty Factor (dB)	Calculated Power Density (dBm/MHz)	Maximum Limit (dBm/MHz)	Result
5190	-4.15	0.86	-3.29	17.00	Pass
5230	-3.45	0.86	-2.59	17.00	Pass

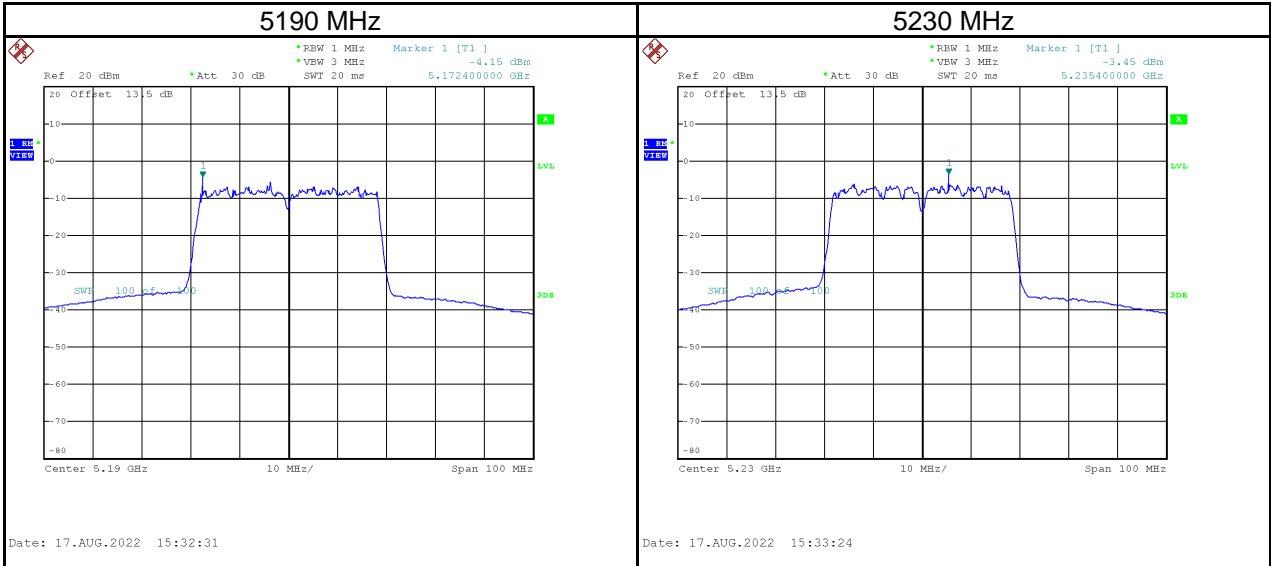

Test Frequency (MHz)	Power Density (dBm/MHz)	Duty Factor (dB)	Calculated Power Density (dBm/MHz)	Maximum Limit (dBm/MHz)	Result
5270	-5.32	0.86	-4.46	11.00	Pass
5310	-3.05	0.86	-2.19	11.00	Pass

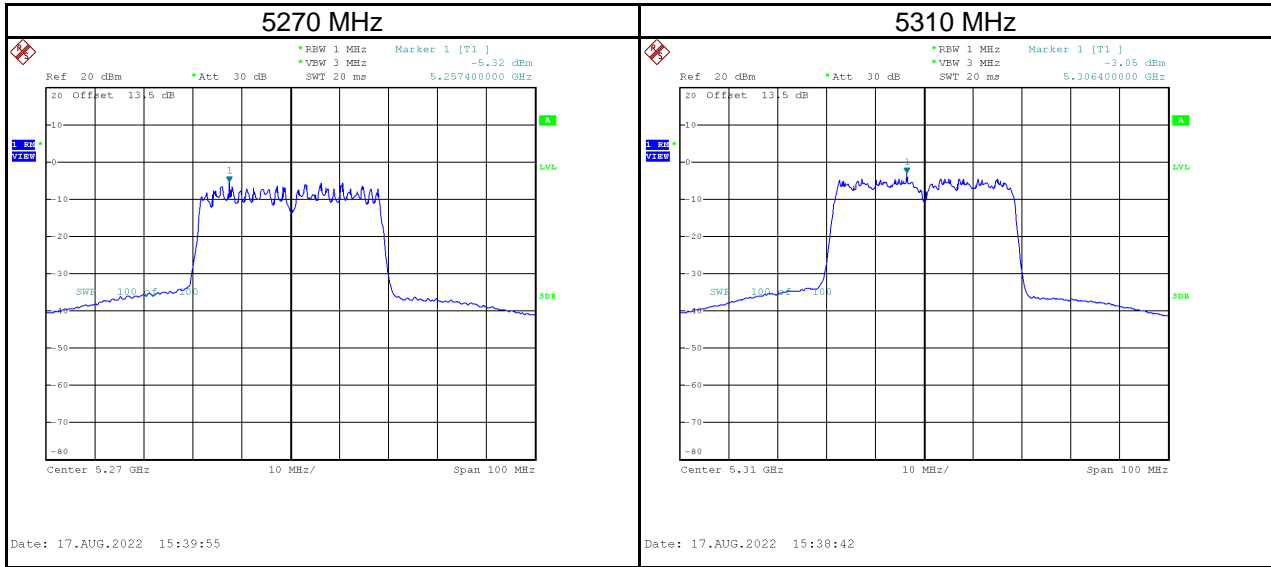

Test Frequency (MHz)	Power Density (dBm/MHz)	Duty Factor (dB)	Calculated Power Density (dBm/MHz)	Maximum Limit (dBm/MHz)	Result
5510	-2.94	0.86	-2.08	11.00	Pass
5550	-2.83	0.86	-1.97	11.00	Pass
5670	-9.06	0.86	-8.20	11.00	Pass

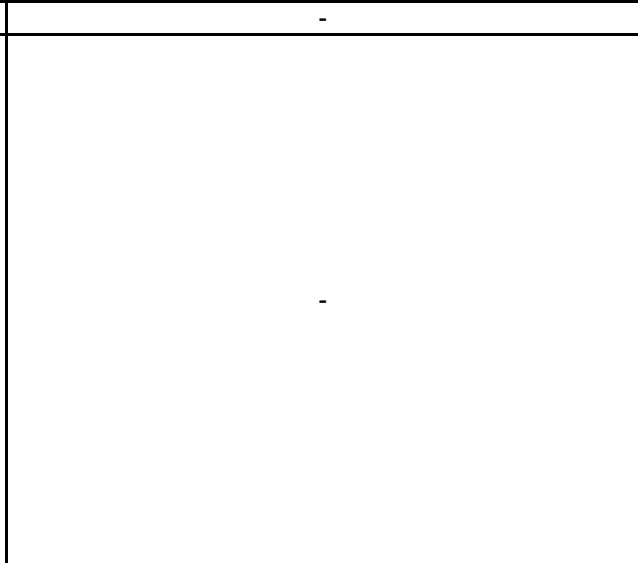
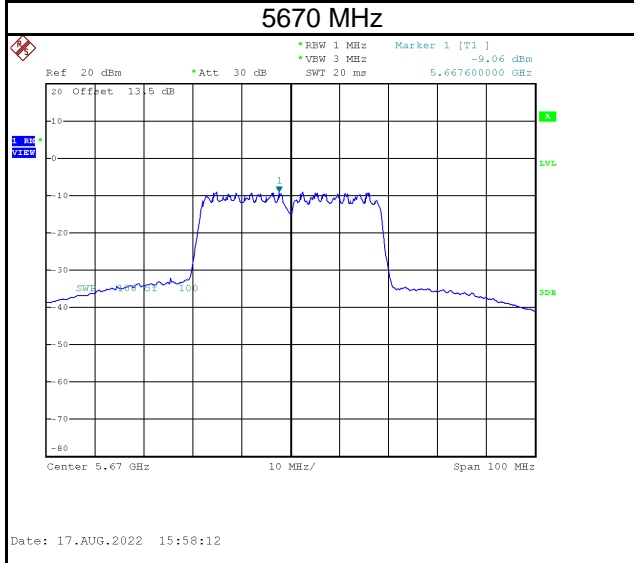
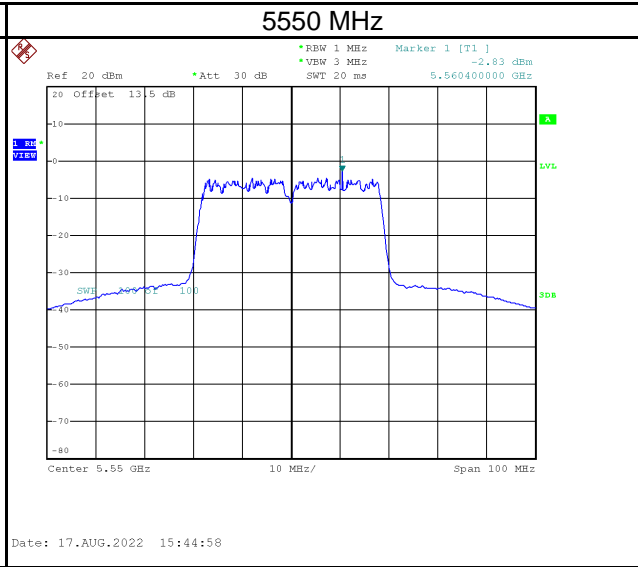
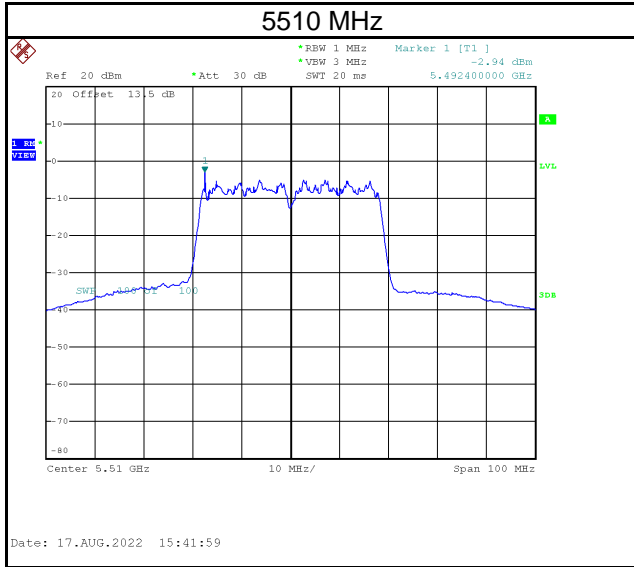

Test Mode	IEEE 802.11ac (VHT40)_Aux Antenna
-----------	-----------------------------------

Test Frequency (MHz)	Power Density (dBm/MHz)	Duty Factor (dB)	Calculated Power Density (dBm/MHz)	Maximum Limit (dBm/MHz)	Result
5190	-3.94	0.86	-3.08	17.00	Pass
5230	-2.41	0.86	-1.55	17.00	Pass

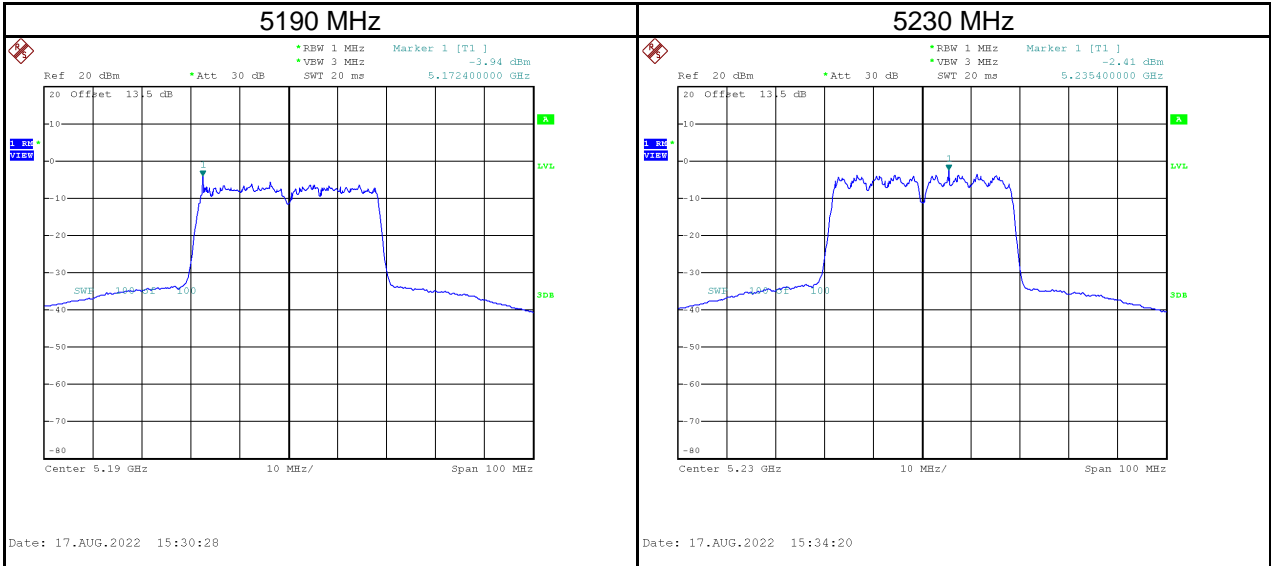

Test Frequency (MHz)	Power Density (dBm/MHz)	Duty Factor (dB)	Calculated Power Density (dBm/MHz)	Maximum Limit (dBm/MHz)	Result
5270	-2.33	0.86	-1.47	11.00	Pass
5310	-1.85	0.86	-0.99	11.00	Pass

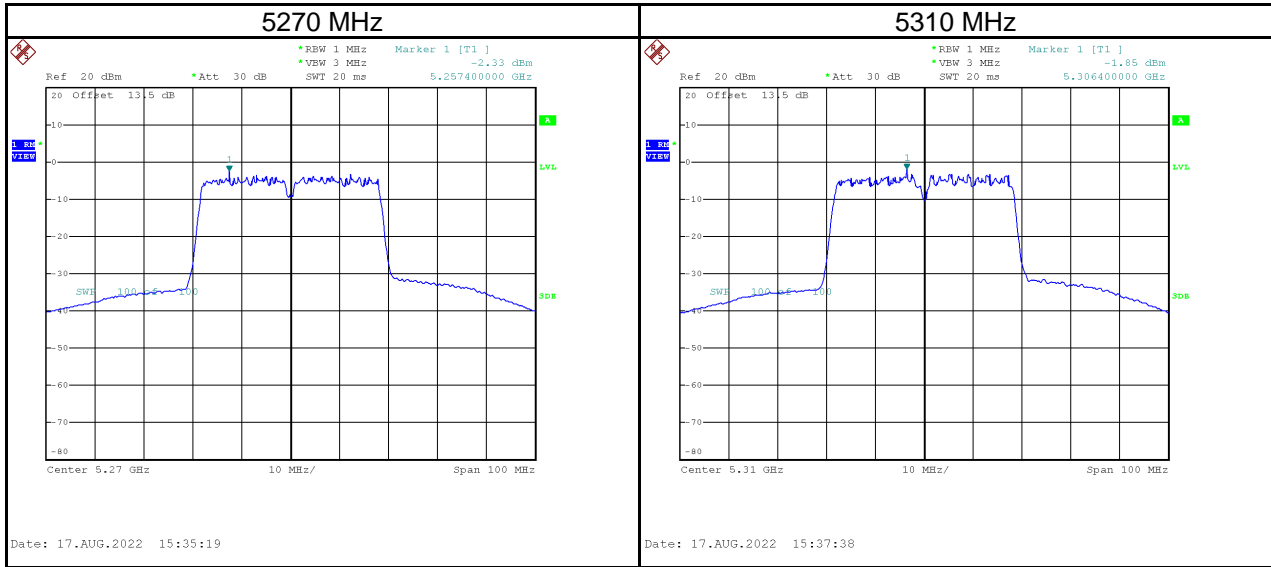

Test Frequency (MHz)	Power Density (dBm/MHz)	Duty Factor (dB)	Calculated Power Density (dBm/MHz)	Maximum Limit (dBm/MHz)	Result
5510	-2.92	0.86	-2.06	11.00	Pass
5550	-2.51	0.86	-1.65	11.00	Pass
5670	-7.36	0.86	-6.50	11.00	Pass

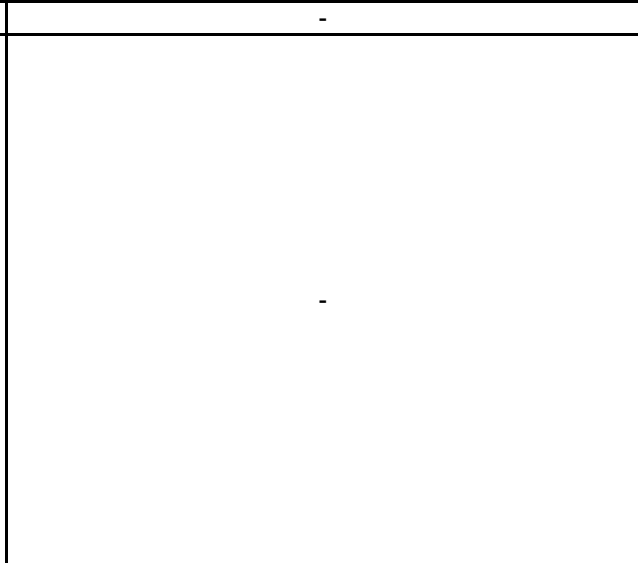
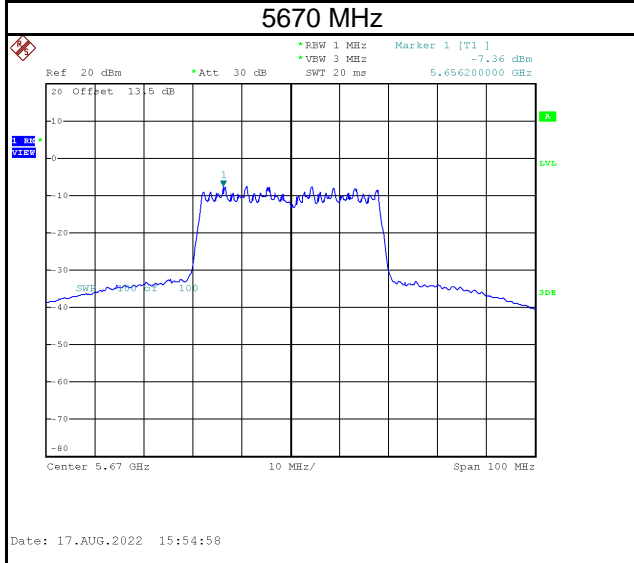
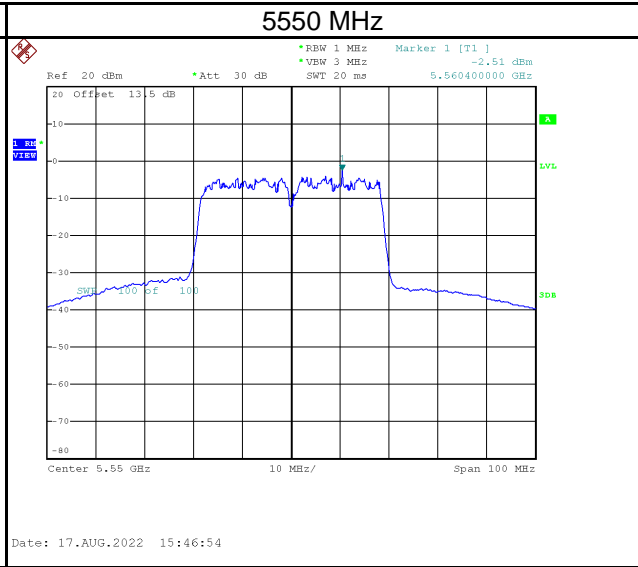
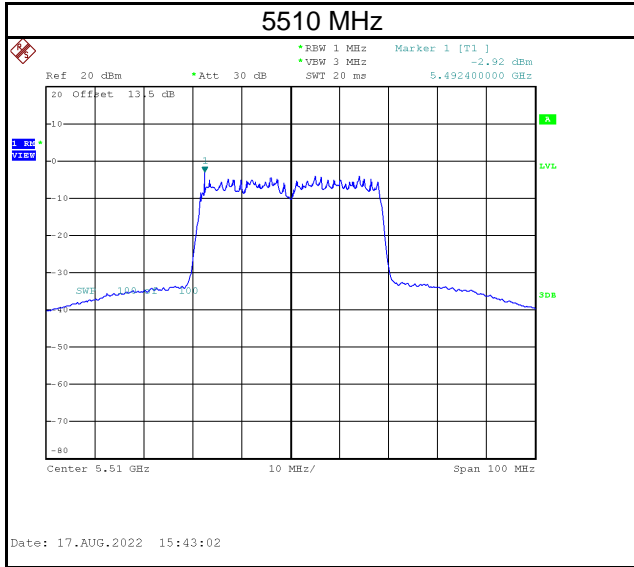

Test Mode	IEEE 802.11ac (VHT40)_Total
-----------	-----------------------------

Test Frequency (MHz)	Calculated Power Density (dBm/MHz)	Maximum Limit (dBm/MHz)	Result
5190	-0.18	17.00	Pass
5230	0.97	17.00	Pass

Test Frequency (MHz)	Calculated Power Density (dBm/MHz)	Maximum Limit (dBm/MHz)	Result
5270	0.29	11.00	Pass
5310	1.46	11.00	Pass

Test Frequency (MHz)	Calculated Power Density (dBm/MHz)	Maximum Limit (dBm/MHz)	Result
5510	0.94	11.00	Pass
5550	1.20	11.00	Pass
5670	-4.26	11.00	Pass

Test Mode	IEEE 802.11ac (VHT80)_Main Antenna
-----------	------------------------------------

Test Frequency (MHz)	Power Density (dBm/MHz)	Duty Factor (dB)	Calculated Power Density (dBm/MHz)	Maximum Limit (dBm/MHz)	Result
5210	-8.66	1.52	-7.14	17.00	Pass

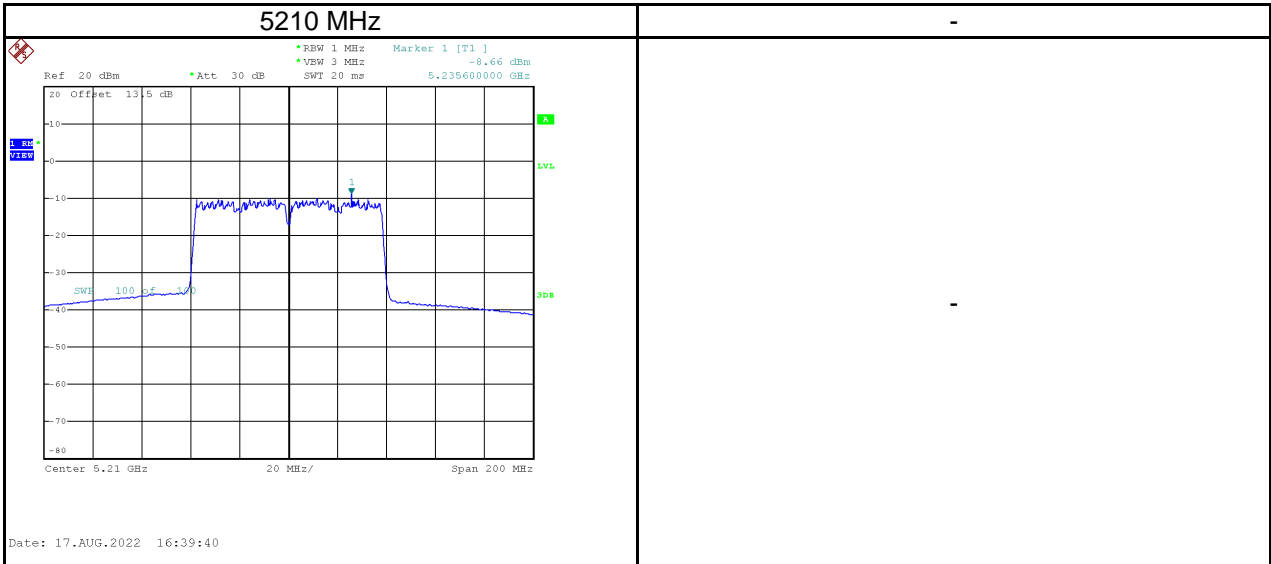

Test Frequency (MHz)	Power Density (dBm/MHz)	Duty Factor (dB)	Calculated Power Density (dBm/MHz)	Maximum Limit (dBm/MHz)	Result
5290	-8.80	1.52	-7.28	11.00	Pass

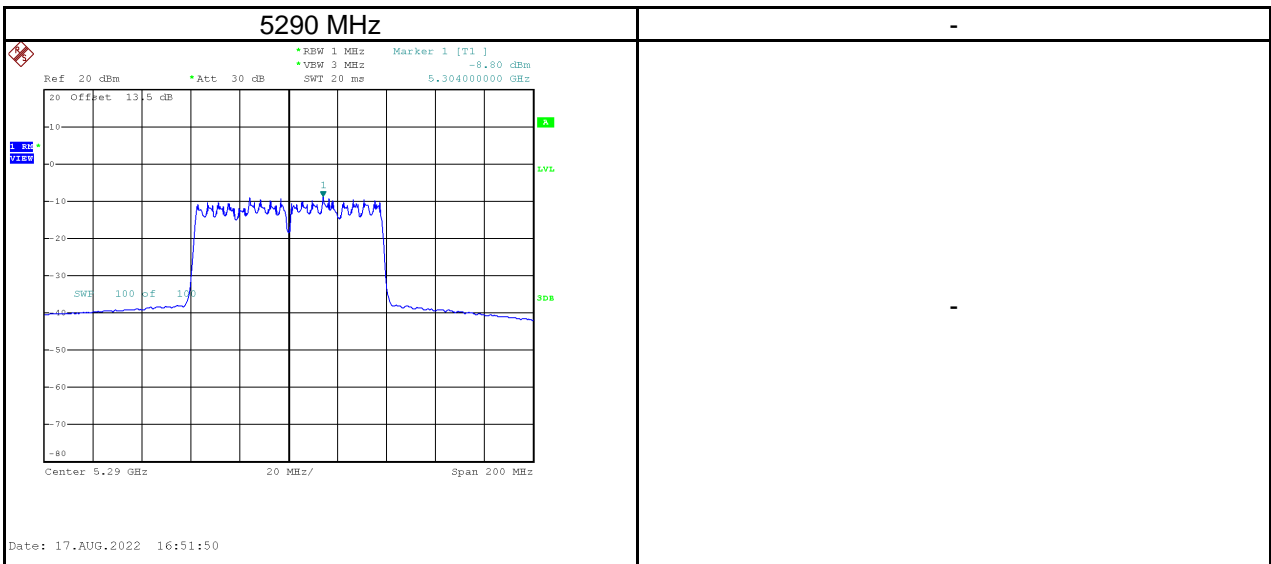

Test Frequency (MHz)	Power Density (dBm/MHz)	Duty Factor (dB)	Calculated Power Density (dBm/MHz)	Maximum Limit (dBm/MHz)	Result
5530	-6.61	1.52	-5.09	11.00	Pass

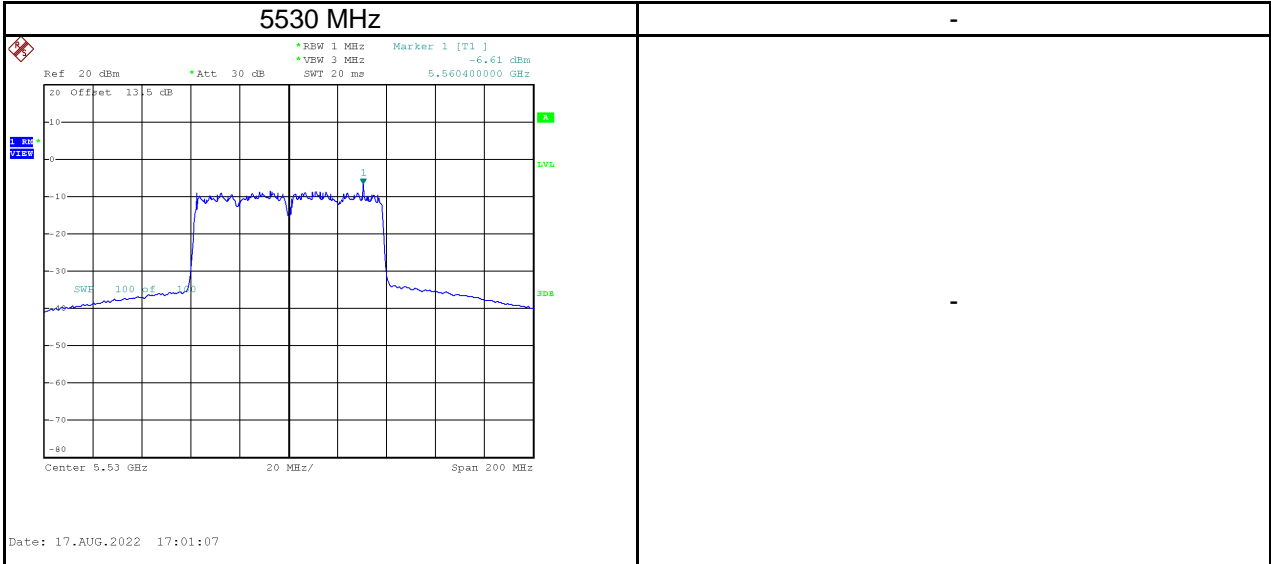

Test Mode	IEEE 802.11ac (VHT80)_Aux Antenna
-----------	-----------------------------------

Test Frequency (MHz)	Power Density (dBm/MHz)	Duty Factor (dB)	Calculated Power Density (dBm/MHz)	Maximum Limit (dBm/MHz)	Result
5210	-8.57	1.52	-7.05	17.00	Pass

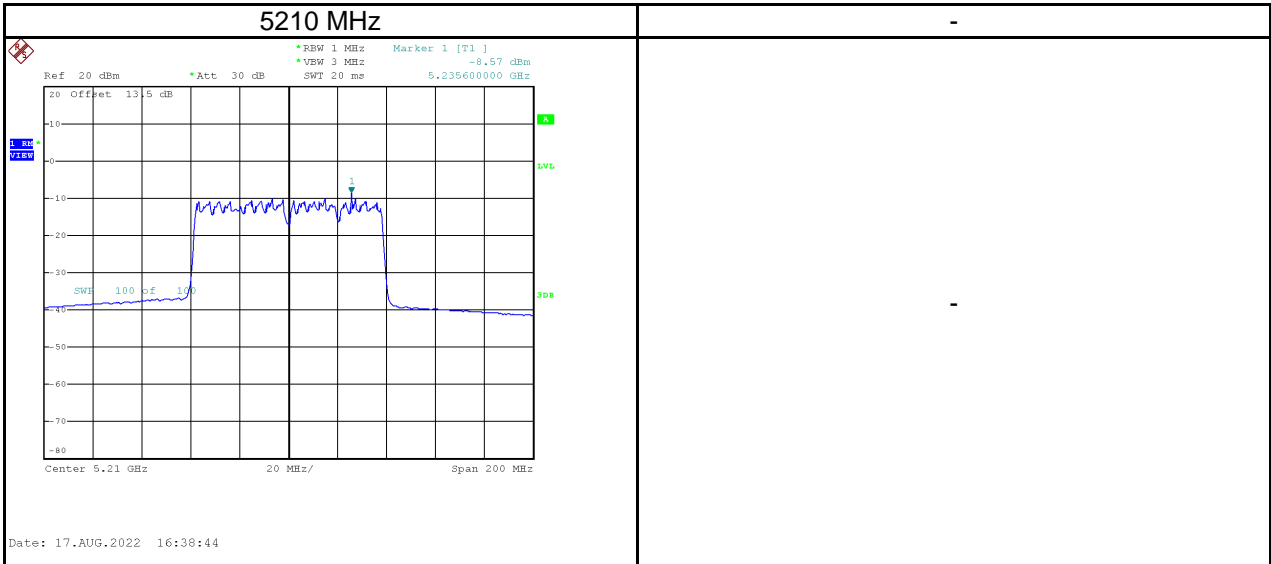

Test Frequency (MHz)	Power Density (dBm/MHz)	Duty Factor (dB)	Calculated Power Density (dBm/MHz)	Maximum Limit (dBm/MHz)	Result
5290	-8.44	1.52	-6.92	11.00	Pass

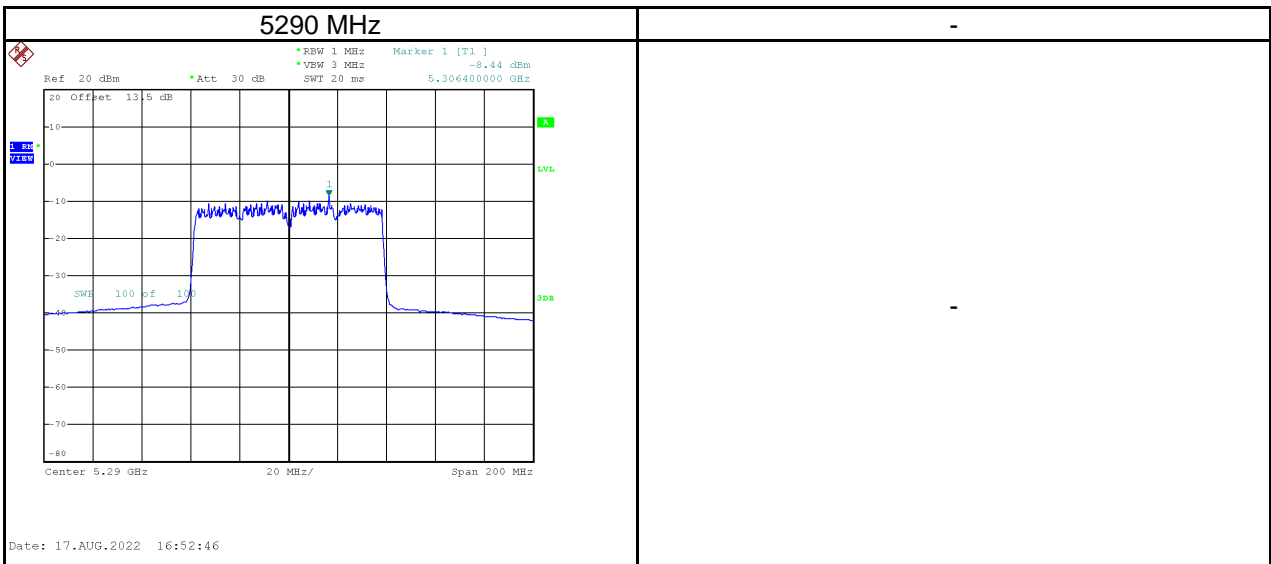

Test Frequency (MHz)	Power Density (dBm/MHz)	Duty Factor (dB)	Calculated Power Density (dBm/MHz)	Maximum Limit (dBm/MHz)	Result
5530	-6.35	1.52	-4.83	11.00	Pass

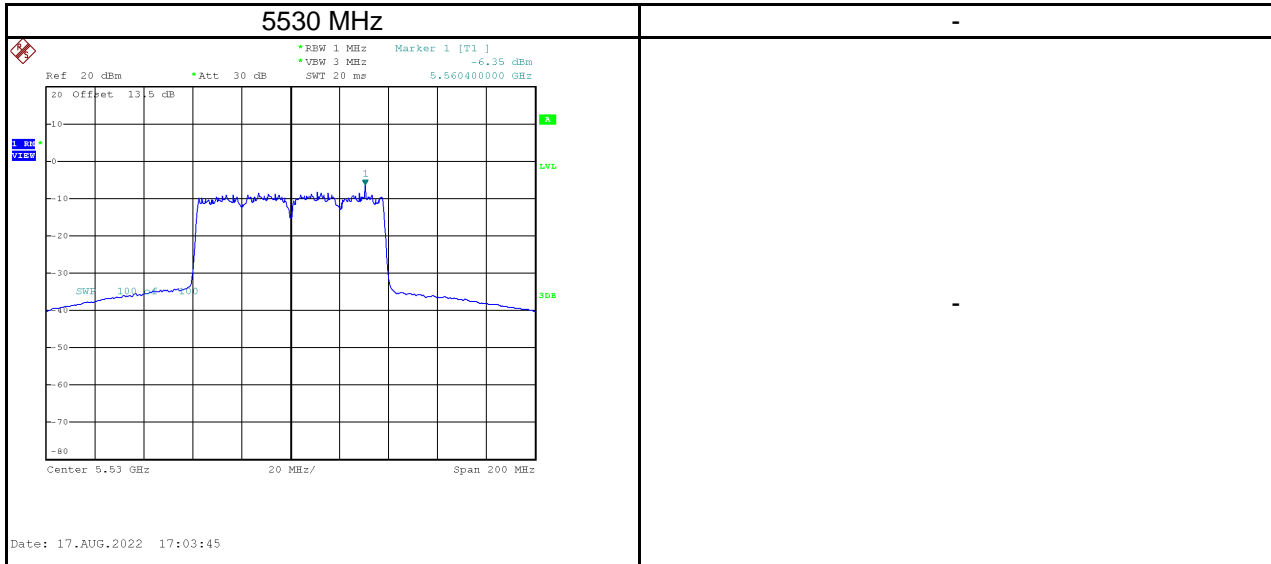

Test Mode	IEEE 802.11ac (VHT80)_Total
-----------	-----------------------------

Test Frequency (MHz)	Calculated Power Density (dBm/MHz)	Maximum Limit (dBm/MHz)	Result
5210	-4.09	17.00	Pass

Test Frequency (MHz)	Calculated Power Density (dBm/MHz)	Maximum Limit (dBm/MHz)	Result
5290	-4.09	11.00	Pass

Test Frequency (MHz)	Calculated Power Density (dBm/MHz)	Maximum Limit (dBm/MHz)	Result
5530	-1.95	11.00	Pass

For Straddle Channel:

Test Mode	IEEE 802.11a_Main Antenna
-----------	---------------------------

Test Frequency (MHz)	Power Density (dBm/MHz)	Duty Factor (dB)	Calculated Power Density (dBm/MHz)	Maximum Limit (dBm/MHz)	Result
5720	-0.98	1.44	0.46	11.00	Pass

Test Frequency (MHz)	Power Density (dBm/100 kHz)	Power Density (dBm/500 kHz)	Duty Factor (dB)	Calculated Power Density (dBm/500 kHz)	Maximum Limit (dBm/500 kHz)	Result
5720	-3.21	-6.22	1.44	-4.78	30.00	Pass

NOTE: $PSD_{dBm/500\text{ kHz}} = PSD_{dBm/100\text{ kHz}} + 10 \times \log_{10}(500\text{ kHz} / 100\text{ kHz})$

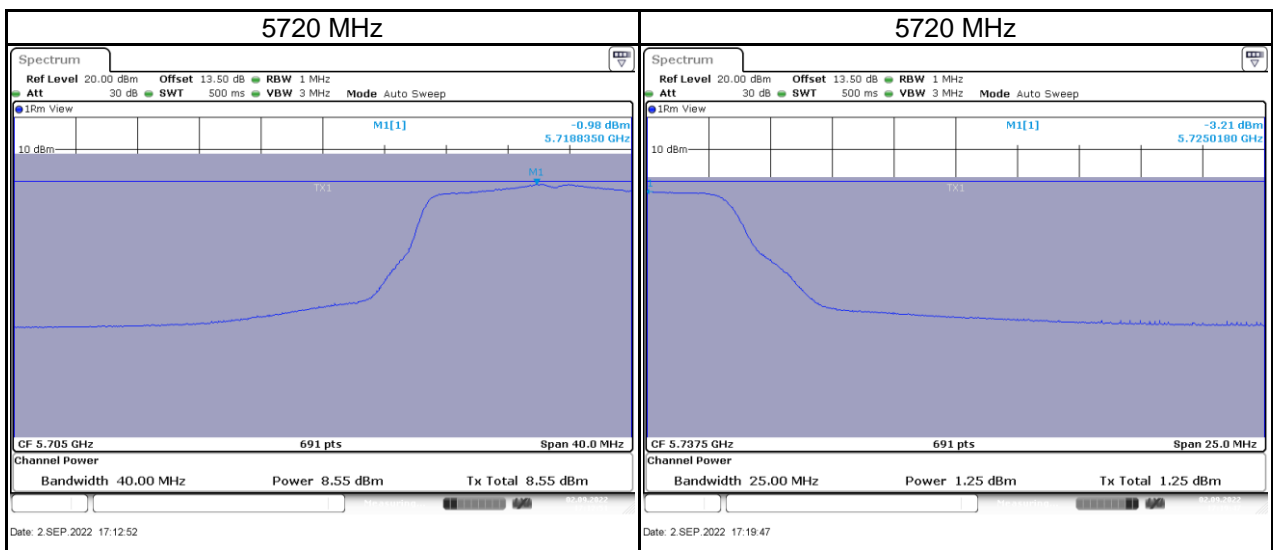

Test Mode	IEEE 802.11a_Aux Antenna
-----------	--------------------------

Test Frequency (MHz)	Power Density (dBm/MHz)	Duty Factor (dB)	Calculated Power Density (dBm/MHz)	Maximum Limit (dBm/MHz)	Result
5720	0.15	1.44	1.59	11.00	Pass

Test Frequency (MHz)	Power Density (dBm/100 kHz)	Power Density (dBm/500 kHz)	Duty Factor (dB)	Calculated Power Density (dBm/500 kHz)	Maximum Limit (dBm/500 kHz)	Result
5720	-2.24	-5.25	1.44	-3.81	30.00	Pass

NOTE: $PSD_{dBm/500\text{ kHz}} = PSD_{dBm/100\text{ kHz}} + 10 \times \log_{10}(500\text{ kHz} / 100\text{ kHz})$

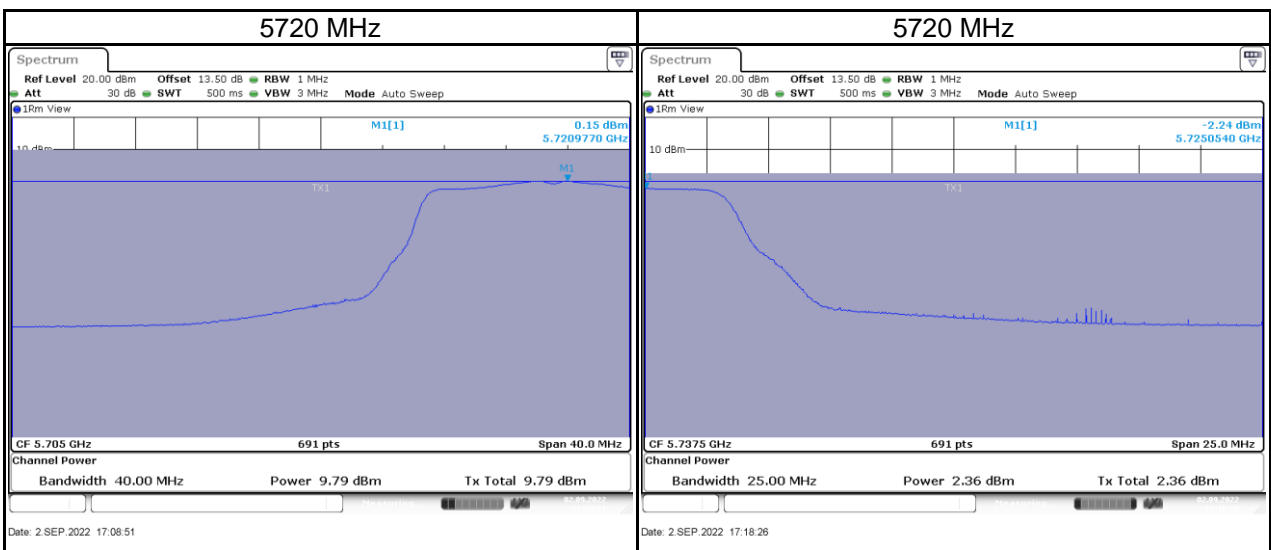

Test Mode	IEEE 802.11a_Total
-----------	--------------------

Test Frequency (MHz)	Calculated Power Density (dBm/MHz)	Maximum Limit (dBm/MHz)	Result
5720	4.08	11.00	Pass
5720	-1.25	30.00	Pass

Test Mode	IEEE 802.11ac (VHT20)_Main Antenna
-----------	------------------------------------

Test Frequency (MHz)	Power Density (dBm/MHz)	Duty Factor (dB)	Calculated Power Density (dBm/MHz)	Maximum Limit (dBm/MHz)	Result
5720	-1.56	0.44	-1.12	11.00	Pass

Test Frequency (MHz)	Power Density (dBm/100 kHz)	Power Density (dBm/500 kHz)	Duty Factor (dB)	Calculated Power Density (dBm/500 kHz)	Maximum Limit (dBm/500 kHz)	Result
5720	-3.81	-6.82	0.44	-6.38	30.00	Pass

NOTE: $PSD_{dBm/500\text{ kHz}} = PSD_{dBm/100\text{ kHz}} + 10 \times \log_{10}(500\text{ kHz} / 100\text{ kHz})$

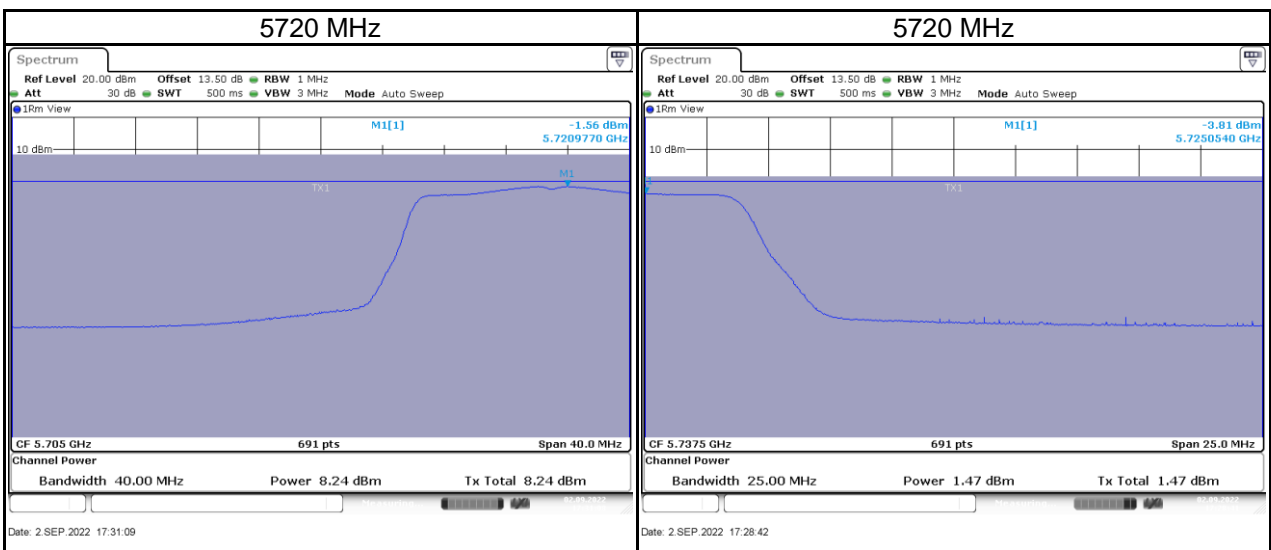

Test Mode	IEEE 802.11ac (VHT20)_Aux Antenna
-----------	-----------------------------------

Test Frequency (MHz)	Power Density (dBm/MHz)	Duty Factor (dB)	Calculated Power Density (dBm/MHz)	Maximum Limit (dBm/MHz)	Result
5720	-0.28	0.44	0.16	11.00	Pass

Test Frequency (MHz)	Power Density (dBm/100 kHz)	Power Density (dBm/500 kHz)	Duty Factor (dB)	Calculated Power Density (dBm/500 kHz)	Maximum Limit (dBm/500 kHz)	Result
5720	-2.73	-5.74	0.44	-5.30	30.00	Pass

NOTE: $PSD_{dBm/500\text{ kHz}} = PSD_{dBm/100\text{ kHz}} + 10 \times \log_{10}(500\text{ kHz} / 100\text{ kHz})$

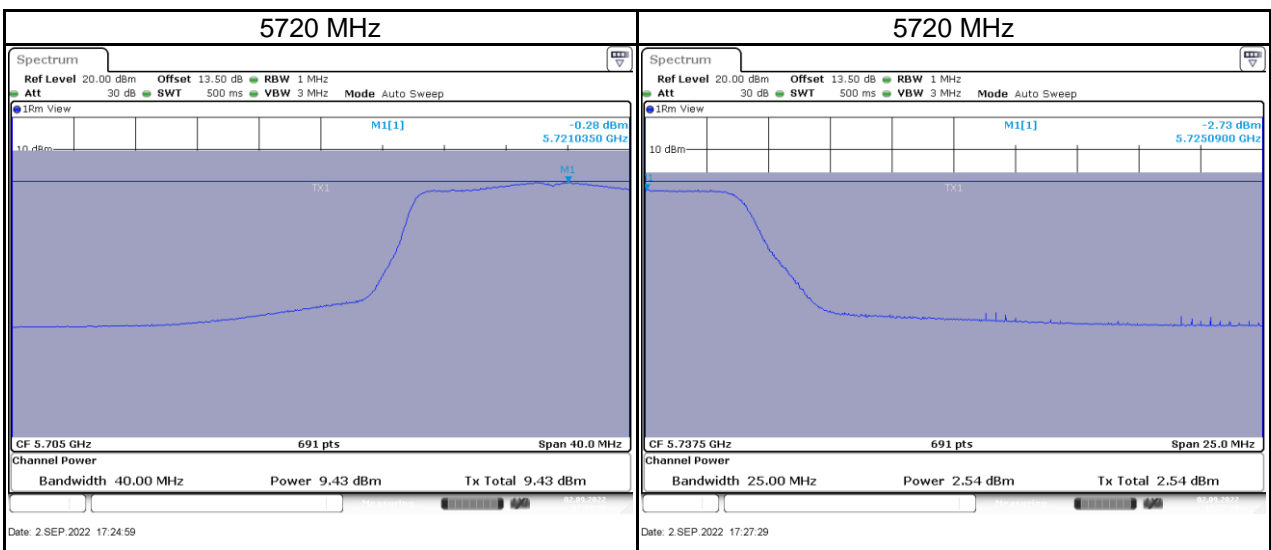

Test Mode	IEEE 802.11ac (VHT20)_Total
-----------	-----------------------------

Test Frequency (MHz)	Calculated Power Density (dBm/MHz)	Maximum Limit (dBm/MHz)	Result
5720	2.58	11.00	Pass
5720	-2.80	30.00	Pass

Test Mode	IEEE 802.11ac (VHT40)_Main Antenna
-----------	------------------------------------

Test Frequency (MHz)	Power Density (dBm/MHz)	Duty Factor (dB)	Calculated Power Density (dBm/MHz)	Maximum Limit (dBm/MHz)	Result
5710	-5.76	0.86	-4.90	11.00	Pass

Test Frequency (MHz)	Power Density (dBm/100 kHz)	Power Density (dBm/500 kHz)	Duty Factor (dB)	Calculated Power Density (dBm/500 kHz)	Maximum Limit (dBm/500 kHz)	Result
5710	-5.96	-8.97	0.86	-8.11	30.00	Pass

NOTE: $PSD_{dBm/500\text{ kHz}} = PSD_{dBm/100\text{ kHz}} + 10 \times \log_{10}(500\text{ kHz} / 100\text{ kHz})$

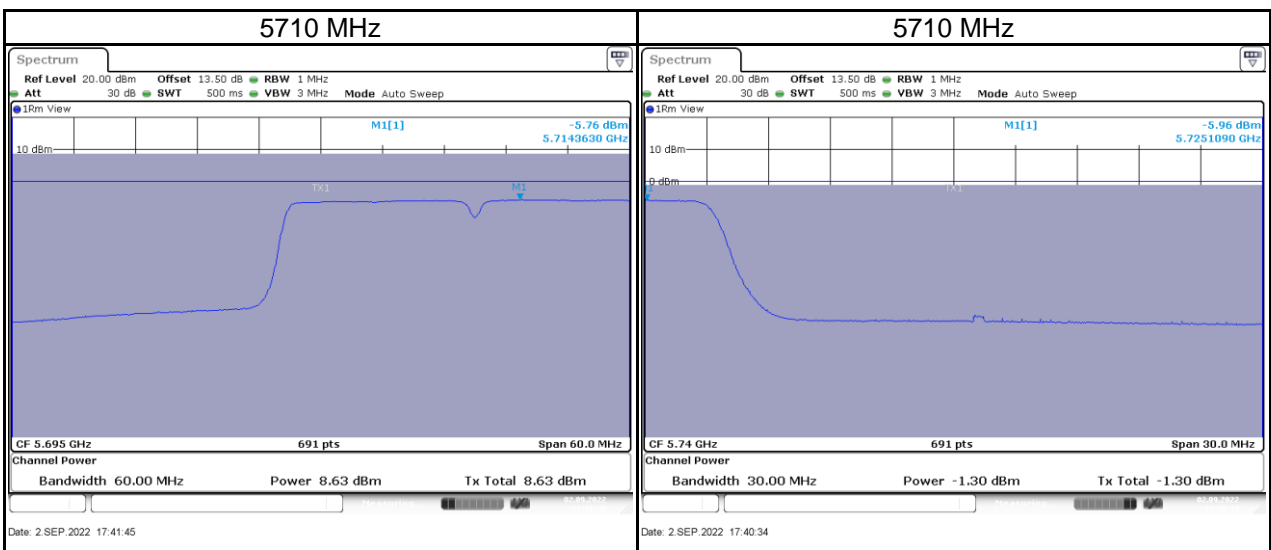

Test Mode	IEEE 802.11ac (VHT40)_Aux Antenna
-----------	-----------------------------------

Test Frequency (MHz)	Power Density (dBm/MHz)	Duty Factor (dB)	Calculated Power Density (dBm/MHz)	Maximum Limit (dBm/MHz)	Result
5710	-5.36	0.86	-4.50	11.00	Pass

Test Frequency (MHz)	Power Density (dBm/100 kHz)	Power Density (dBm/500 kHz)	Duty Factor (dB)	Calculated Power Density (dBm/500 kHz)	Maximum Limit (dBm/500 kHz)	Result
5710	-5.58	-8.59	0.86	-7.73	30.00	Pass

NOTE: $PSD_{dBm/500\text{ kHz}} = PSD_{dBm/100\text{ kHz}} + 10 \times \log_{10}(500\text{ kHz} / 100\text{ kHz})$

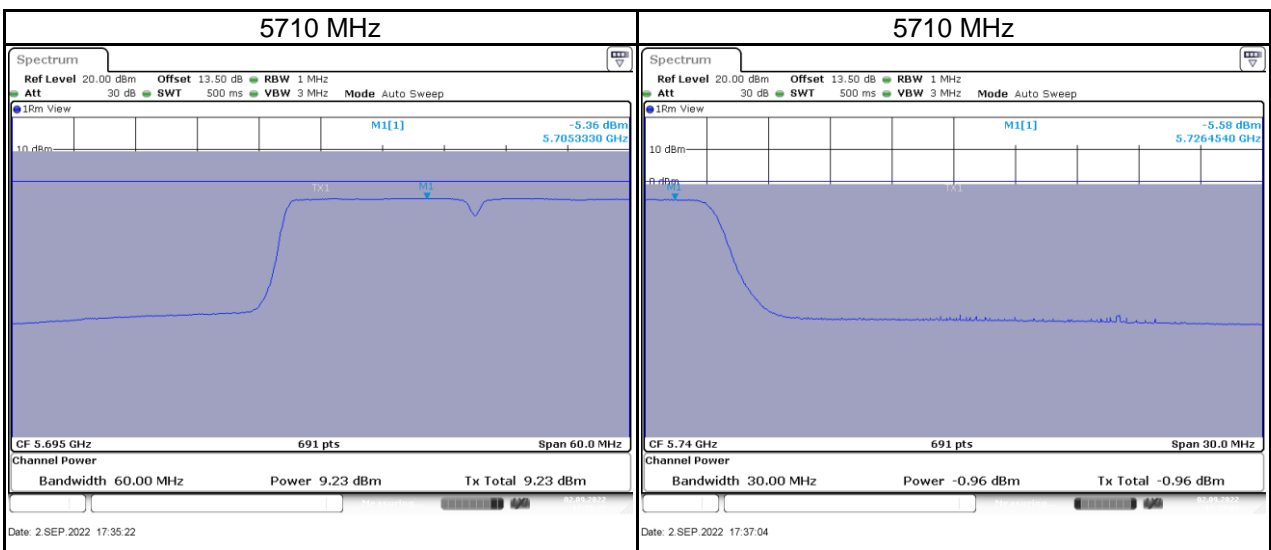

Test Mode	IEEE 802.11ac (VHT40)_Total
-----------	-----------------------------

Test Frequency (MHz)	Calculated Power Density (dBm/MHz)	Maximum Limit (dBm/MHz)	Result
5710	-1.69	11.00	Pass
5710	-4.91	30.00	Pass

Test Mode	IEEE 802.11ac (VHT80)_Main Antenna
-----------	------------------------------------

Test Frequency (MHz)	Power Density (dBm/MHz)	Duty Factor (dB)	Calculated Power Density (dBm/MHz)	Maximum Limit (dBm/MHz)	Result
5690	-9.04	1.52	-7.52	11.00	Pass

Test Frequency (MHz)	Power Density (dBm/100 kHz)	Power Density (dBm/500 kHz)	Duty Factor (dB)	Calculated Power Density (dBm/500 kHz)	Maximum Limit (dBm/500 kHz)	Result
5690	-9.26	-12.27	1.52	-10.75	30.00	Pass

NOTE: $PSD_{dBm/500\text{ kHz}} = PSD_{dBm/100\text{ kHz}} + 10 \times \log_{10}(500\text{ kHz} / 100\text{ kHz})$

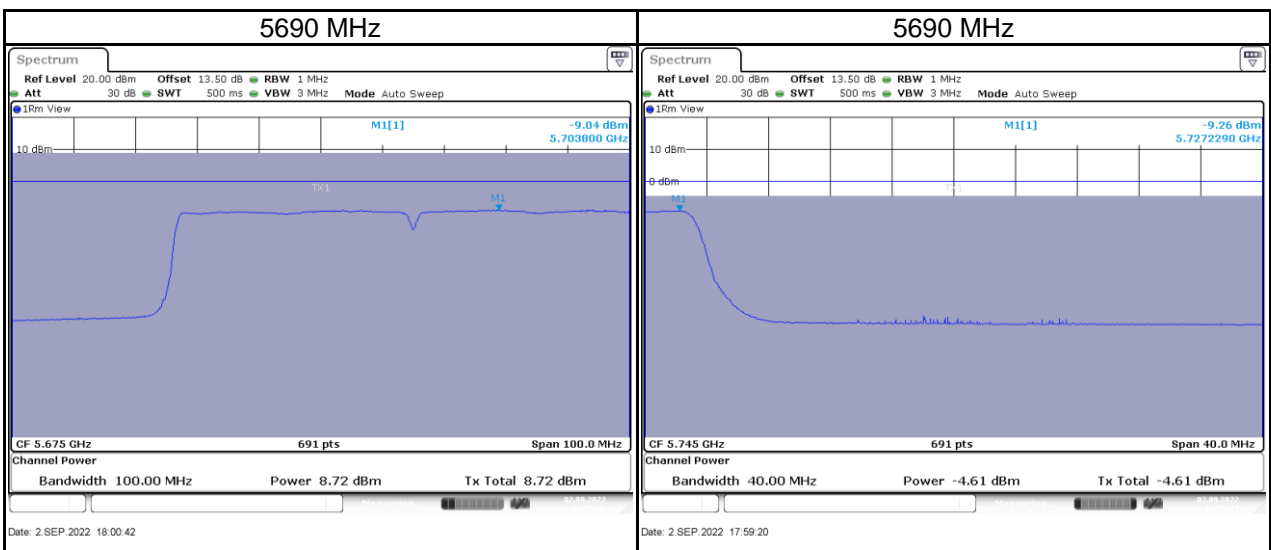

Test Mode	IEEE 802.11ac (VHT80)_Aux Antenna
-----------	-----------------------------------

Test Frequency (MHz)	Power Density (dBm/MHz)	Duty Factor (dB)	Calculated Power Density (dBm/MHz)	Maximum Limit (dBm/MHz)	Result
5690	-7.92	1.52	-6.40	11.00	Pass

Test Frequency (MHz)	Power Density (dBm/100 kHz)	Power Density (dBm/500 kHz)	Duty Factor (dB)	Calculated Power Density (dBm/500 kHz)	Maximum Limit (dBm/500 kHz)	Result
5690	-8.78	-11.79	1.52	-10.27	30.00	Pass

NOTE: $PSD_{dBm/500\text{ kHz}} = PSD_{dBm/100\text{ kHz}} + 10 \times \log_{10}(500\text{ kHz} / 100\text{ kHz})$

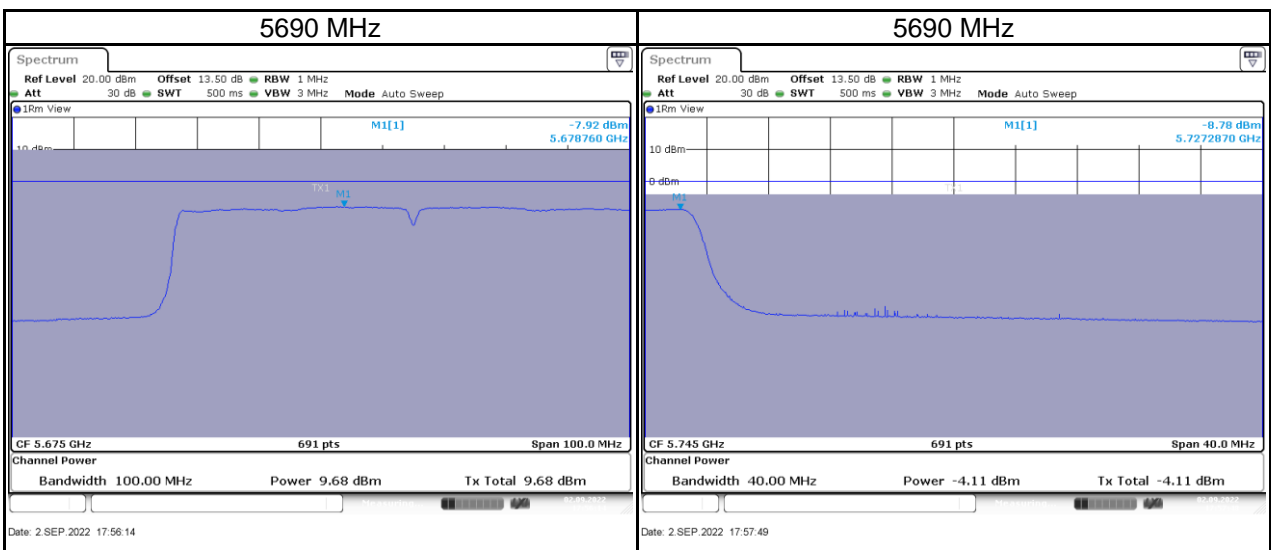

Test Mode	IEEE 802.11ac (VHT80)_Total
-----------	-----------------------------

Test Frequency (MHz)	Calculated Power Density (dBm/MHz)	Maximum Limit (dBm/MHz)	Result
5690	-3.92	11.00	Pass
5690	-7.50	30.00	Pass

End of Test Report