



RADIO TEST REPORT

Test Report No. : 31HE0169-HO-02-A-R1

Applicant : Ricoh Company Ltd
Type of Equipment : Wireless LAN Module
Model No. : SX-PCEGN-R
FCC ID : BBP-WLA1B01
Test regulation : FCC Part 15 Subpart C: 2010
Test Result : Complied

1. This test report shall not be reproduced in full or partial, without the written approval of UL Japan, Inc.
2. The results in this report apply only to the sample tested.
3. This sample tested is in compliance with the above regulation.
4. The test results in this report are traceable to the national or international standards.
5. This test report must not be used by the customer to claim product certification, approval, or endorsement by NVLAP, NIST, or any agency of the Federal Government.
6. This report is a revised version of 31HE0169-HO-02-A. 31HE0169-HO-02-A is replaced with this report.

Date of test: April 21 to May 22, 2011

Representative test engineer: T. Shimada
Takumi Shimada
Engineer of WiSE Japan,
UL Verification Service

Approved by: T. Hatakeyama
Takahiro Hatakeyama
Leader of WiSE Japan,
UL Verification Service



NVLAP LAB CODE: 200572-0

This laboratory is accredited by the NVLAP LAB CODE 200572-0, U.S.A. The tests reported herein have been performed in accordance with its terms of accreditation. *As for the range of Accreditation in NVLAP, you may refer to the WEB address, <http://www.ul.com/japan/jpn/pages/services/emc/about/mark1/index.jsp#nvlap>

CONTENTS	PAGE
SECTION 1: Customer information.....	3
SECTION 2: Equipment under test (E.U.T.).....	3
SECTION 3: Test specification, procedures & results.....	4
SECTION 4: Operation of E.U.T. during testing.....	7
SECTION 5: Conducted Emission.....	10
SECTION 6: Radiated Spurious Emission	11
SECTION 7: Antenna Terminal Conducted Tests.....	12
APPENDIX 1: Photographs of test setup.....	13
Conducted Emission	13
Radiated Spurious Emission	14
Worst Case Position	15
APPENDIX 2: Data of EMI test.....	16
Conducted Emission	16
6dB Bandwidth	17
Maximum Peak Output Power	21
Radiated Spurious Emission	27
The tested burst timing.....	39
Conducted Spurious Emission	41
Conducted Emission Band Edge compliance	71
Power Density	74
99% Occupied Bandwidth	80
APPENDIX 3: Test instruments	83

SECTION 1: Customer information

Company Name : Ricoh Company Ltd
Address : 810 Shimoimaizumi, Ebina-Shi, Kanagawa-ken, 243-0460, Japan
Telephone Number : +81-46-292-6870
Facsimile Number : +81-3-6673-4430
Contact Person : Taku Matsuyama

*Remarks:

Ricoh Company Ltd designates silex technology, Inc. as manufacturer of the product (Wireless LAN Module).

SECTION 2: Equipment under test (E.U.T.)

2.1 Identification of E.U.T.

Type of Equipment : Wireless LAN Module
Model No. : SX-PCEGN-R
Serial No. : Refer to Section 4, Clause 4.2
Rating : DC3.3V
Receipt Date of Sample : April 21, 2011
Country of Mass-production : Japan
Condition of EUT : Production prototype
(Not for Sale: This sample is equivalent to mass-produced items.)
Modification of EUT : No Modification by the test lab

2.2 Product Description

Model No: SX-PCEGN-R (referred to as the EUT in this report) is the Wireless LAN Module.

Equipment Type : Transceiver
Clock frequency : 40MHz
Method of Frequency Generation : Synthesizer
Operating voltage(Power Supply) : DC3.3V
Operating voltage (inner) : DC1.2V
Maximum Antenna Gain : 2.0dBi

	IEEE802.11b	IEEE802.11g	IEEE802.11n (20HT)	IEEE802.11n (40HT)
Frequency of operation	2412-2462MHz		2412 - 2462MHz	2422 - 2452MHz
Type of modulation	DSSS (CCK, DQPSK, DBPSK)	OFDM (64QAM, 16QAM, QPSK, BPSK)	OFDM (64QAM, 16QAM, QPSK, BPSK)	
Channel spacing	5MHz		5MHz	5MHz
Antenna type	Helical Antenna			
Antenna Connector type	U.FL Alternative connector			

UL Japan, Inc.

Head Office EMC Lab.

4383-326 Asama-cho, Ise-shi, Mie-ken 516-0021 JAPAN

Telephone : +81 596 24 8116

Facsimile : +81 596 24 8124

SECTION 3: Test specification, procedures & results

3.1 Test Specification

Test Specification : FCC Part 15 Subpart C: 2010, final revised on December 6, 2010 and effective January 5, 2011

Title : FCC 47CFR Part15 Radio Frequency Device Subpart C Intentional Radiators
Section 15.207 Conducted limits
Section 15.247 Operation within the bands 902-928MHz,
2400-2483.5MHz, and 5725-5850MHz

3.2 Procedures and results

Item	Test Procedure	Specification	Worst margin	Results	Remarks
Conducted Emission	FCC: ANSI C63.4:2003 7. AC powerline Conducted Emission measurements IC: RSS-Gen 7.2.4	FCC: Section 15.207 IC: RSS-Gen 7.2.4	QP 11.6dB, 4.84187MHz, L AV 10.3dB, 4.84187MHz, L	Complied	-
6dB Bandwidth	FCC: "Guidance on Measurement of Digital Transmission Systems Operating under Section15.247" IC: RSS-Gen 4.6.2	FCC: Section 15.247(a)(2) IC: RSS-210 A8.2(a)	See data.	Complied	Conducted
Maximum Peak Output Power	FCC: "Guidance on Measurement of Digital Transmission Systems Operating under Section15.247" IC: RSS-Gen 4.8	FCC: Section 15.247(b)(3) IC: RSS-210 A8.4(4)		Complied	Conducted
Power Density	FCC: "Guidance on Measurement of Digital Transmission Systems Operating under Section15.247" IC: -	FCC: Section 15.247 (e) IC: RSS-210 A8.2(b)		Complied	Conducted
Spurious Emission Restricted Band Edges	FCC: "Guidance on Measurement of Digital Transmission Systems Operating under Section15.247" IC: RSS-Gen 4.9	FCC: Section15.247(d) IC: RSS-210 A8.5 RSS-Gen 7.2.3	1.3dB 2483.500MHz, PK/AV, Hori. 3282.665MHz, AV, Vert.	Complied	Conducted/ Radiated

Note: UL Japan, Inc.'s EMI Work Procedures No. 13-EM-W0420 and 13-EM-W0422.

* In case any questions arise about test procedure, ANSI C63.4: 2003 is also referred.

FCC 15.31 (e)

The RF Module has own regulator.

The RF Module is constantly provided voltage through own regulator regardless of input voltage (DC3.3V).

Therefore, this EUT complies with the requirement.

FCC Part 15.203/212 Antenna requirement

The EUT has a unique antenna connector (U.FL Alternative connector).

Therefore the equipment complies with the requirement of 15.203/212.

UL Japan, Inc.

Head Office EMC Lab.

4383-326 Asama-cho, Ise-shi, Mie-ken 516-0021 JAPAN

Telephone : +81 596 24 8116

Facsimile : +81 596 24 8124

3.3 Addition to standard

Item	Test Procedure	Specification	Worst margin	Results	Remarks
99% Occupied Bandwidth	IC: RSS-Gen 4.6.1	IC: RSS-Gen 4.6.1	N/A	-	Conducted

Other than above, no addition, exclusion nor deviation has been made from the standard.

3.4 Uncertainty

EMI

The following uncertainties have been calculated to provide a confidence level of 95% using a coverage factor k=2.

Test room (semi-anechoic chamber)	Conducted emission (+dB)
	150kHz-30MHz
No.1	3.1dB
No.2	3.3dB
No.3	3.7dB
No.4	3.2dB

Test room (semi-anechoic chamber)	Radiated emission						
	(3m*)(+dB)				(1m*)(+dB)		(0.5m*)(+dB)
	9kHz -30MHz	30MHz -300MHz	300MHz -1GHz	1GHz -10GHz	10GHz -18GHz	18GHz -26.5GHz	26.5GHz -40GHz
No.1	3.5dB	5.1dB	5.2dB	4.8dB	5.1dB	4.4dB	4.3dB
No.2	4.0dB	5.1dB	5.2dB	4.8dB	5.0dB	4.3dB	4.2dB
No.3	4.2dB	4.7dB	5.2dB	4.8dB	5.0dB	4.5dB	4.2dB
No.4	4.0dB	5.0dB	5.1dB	4.8dB	5.0dB	5.1dB	4.2dB

*3m/1m/0.5m = Measurement distance

Power meter (+dB)	
Below 1GHz	Above 1GHz
1.0dB	1.0dB

Antenna terminal conducted emission and Power density (+dB)			Antenna terminal conducted emission (+dB)		Channel power (+dB)
Below 1GHz	1GHz-3GHz	3GHz-18GHz	18GHz-26.5GHz	26.5GHz-40GHz	
1.0dB	1.1dB	2.7dB	3.2dB	3.3dB	1.5dB

Conducted Emission test

The data listed in this test report has enough margin, more than the site margin.

Radiated emission test(3m)

The data listed in this report meets the limits unless the uncertainty is taken into consideration.

UL Japan, Inc.

Head Office EMC Lab.

4383-326 Asama-cho, Ise-shi, Mie-ken 516-0021 JAPAN

Telephone : +81 596 24 8116

Facsimile : +81 596 24 8124

3.5 Test Location

UL Japan, Inc. Head Office EMC Lab. *NVLAP Lab. code: 200572-0
4383-326 Asama-cho, Ise-shi, Mie-ken 516-0021 JAPAN
Telephone : +81 596 24 8116 Facsimile : +81 596 24 8124

	FCC Registration Number	IC Registration Number	Width x Depth x Height (m)	Size of reference ground plane (m) / horizontal conducting plane	Other rooms
No.1 semi-anechoic chamber	313583	2973C-1	19.2 x 11.2 x 7.7m	7.0 x 6.0m	No.1 Power source room
No.2 semi-anechoic chamber	655103	2973C-2	7.5 x 5.8 x 5.2m	4.0 x 4.0m	-
No.3 semi-anechoic chamber	148738	2973C-3	12.0 x 8.5 x 5.9m	6.8 x 5.75m	No.3 Preparation room
No.3 shielded room	-	-	4.0 x 6.0 x 2.7m	N/A	-
No.4 semi-anechoic chamber	134570	2973C-4	12.0 x 8.5 x 5.9m	6.8 x 5.75m	No.4 Preparation room
No.4 shielded room	-	-	4.0 x 6.0 x 2.7m	N/A	-
No.5 semi-anechoic chamber	-	-	6.0 x 6.0 x 3.9m	6.0 x 6.0m	-
No.6 shielded room	-	-	4.0 x 4.5 x 2.7m	4.75 x 5.4 m	-
No.6 measurement room	-	-	4.75 x 5.4 x 3.0m	4.75 x 4.15 m	-
No.7 shielded room	-	-	4.7 x 7.5 x 2.7m	4.7 x 7.5m	-
No.8 measurement room	-	-	3.1 x 5.0 x 2.7m	N/A	-
No.9 measurement room	-	-	8.0 x 4.5 x 2.8m	2.0 x 2.0m	-
No.10 measurement room	-	-	2.6 x 2.8 x 2.5m	2.4 x 2.4m	-
No.11 measurement room	-	-	3.1 x 3.4 x 3.0m	2.4 x 3.4m	-

* Size of vertical conducting plane (for Conducted Emission test) : 2.0 x 2.0m for No.1, No.2, No.3, and No.4 semi-anechoic chambers and No.3 and No.4 shielded rooms.

3.6 Test set up, Data of EMI, and Test instruments

Refer to APPENDIX.

SECTION 4: Operation of E.U.T. during testing

4.1 Operating Mode(s)

Test operating mode was determined as follows according to “Section 1 of 6 802.11 a/b/g/n testing - Managing Complex Regulatory Approvals - ” of TCB Council Workshop October 2009.

Mode		Remarks*										
IEEE 802.11b (11b)		11Mbps (Long), PN9										
IEEE 802.11g (11g)		9Mbps, PN9										
IEEE 802.11n MIMO 20MHz BW (11n-20)		MCS 13, PN9										
IEEE 802.11n MIMO 40MHz BW (11n-40)		MCS 8, PN9										
*The worst condition was determined based on the test result of Maximum Peak Output Power (Mid Channel)												
*Power of the EUT was set by the software as follows; Power settings:												
ch	1	2	3	4	5	6	7	8	9	10	11	
11b	15dBm	15dBm	15dBm	15dBm	15dBm	15dBm	15dBm	15dBm	15dBm	15dBm	15dBm	15dBm
11g	13dBm	15dBm	15dBm	15dBm	15dBm	15dBm	15dBm	15dBm	15dBm	15dBm	15dBm	11.5dBm
11n-20	9dBm	12dBm	12dBm	12dBm	12dBm	12dBm	12dBm	12dBm	12dBm	12dBm	12dBm	11dBm
11n-40	-	-	8dBm	12.5dBm	12.5dBm	12.5dBm	12.5dBm	12.5dBm	8dBm	-	-	-
Software: 9K Atheros Radio test												
* Any conditions under the normal use do not exceed the condition of setting. In addition, end users cannot change the settings of the output power of the product.												

*The details of Operating mode(s)

Test Item	Operating Mode	Tested Antenna	Tested frequency
Conducted Emission	11n-40 Tx *1)	0+1	2437MHz *1)
Spurious Emission (Above 1GHz) 6dB Bandwidth Maximum Peak Output Power Power Density 99% Occupied Bandwidth	11b Tx 11g Tx	0	2412MHz 2437MHz 2462MHz
	11n-20 Tx	0+1	2412MHz 2437MHz 2462MHz
	11n-40 Tx	0+1	2422MHz 2437MHz 2452MHz
Spurious Emission (Below 1GHz)	11n-40 Tx *1)	0+1	2437MHz *1)
*1) The mode and the tested frequency were used for the test as a representative, because they had the highest power at Maximum Peak Output Power test.			

UL Japan, Inc.

Head Office EMC Lab.

4383-326 Asama-cho, Ise-shi, Mie-ken 516-0021 JAPAN

Telephone : +81 596 24 8116

Facsimile : +81 596 24 8124

4.2 Configuration and peripherals

[Conducted emission test]

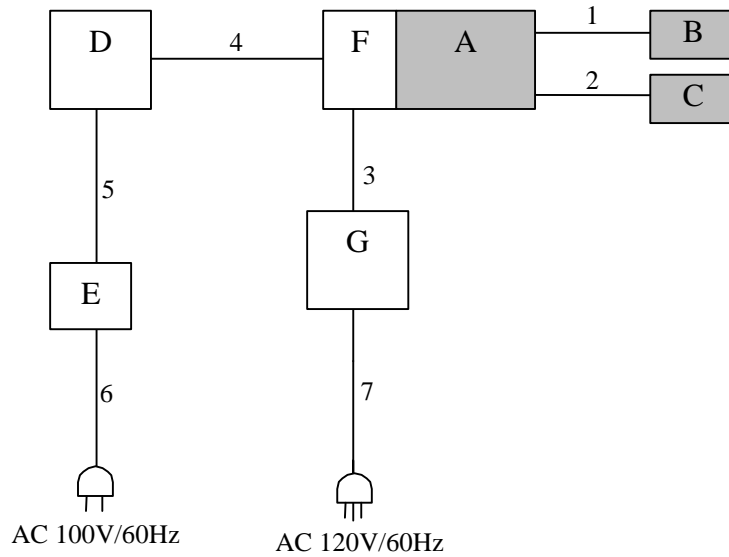

[Radiated emission test]

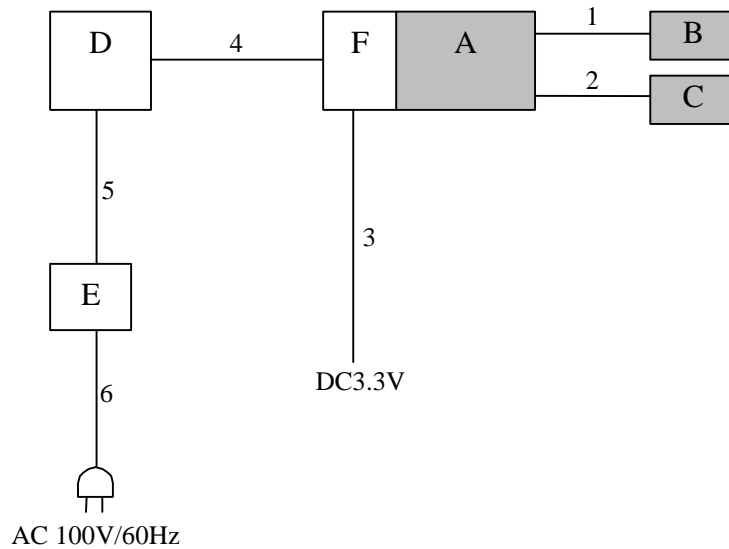

* Cabling and setup(s) were taken into consideration and test data was taken under worse case conditions.

Description of EUT

No.	Item	Model number	Serial number	Manufacturer	Remarks
A	Wireless LAN Module	SX-PCEGN-R	008092-011870	silex technology, Inc.	EUT
B	Antenna	AF 216M245001	20110607-1	silex technology, Inc.	EUT
C	Antenna	AF 216M245001	20110607-2	silex technology, Inc.	EUT
D	Laptop PC	E6510	SX00804	DELL	-
E	AC Adapter	LA90PE0-01	CN-03T6XF-71615-04L-06DB-A01	DELL	-
F	Jig board	-	-	silex technology, Inc.	-
G	DC Power Supply	6654A	MY40000510	Agilent	-

List of cables used

No.	Name	Length (m)	Shield		Remarks
			Cable	Connector	
1	Antenna Cable	0.2	Shielded	Shielded	-
2	Antenna Cable	0.2	Shielded	Shielded	-
3	DC Cable	2.4	Unshielded	Unshielded	-
4	Signal Cable	0.3	Shielded	Shielded	-
5	DC Cable	1.8	Unshielded	Unshielded	-
6	AC Cable	0.9	Unshielded	Unshielded	-
7	AC Cable	1.8	Unshielded	Unshielded	-

UL Japan, Inc.

Head Office EMC Lab.

4383-326 Asama-cho, Ise-shi, Mie-ken 516-0021 JAPAN

Telephone : +81 596 24 8116

Facsimile : +81 596 24 8124

SECTION 5: Conducted Emission

Test Procedure and conditions

EUT was placed on a urethane platform of nominal size, 1.0m by 1.5m, raised 0.8m above the conducting ground plane. The rear of tabletop was located 40cm to the vertical conducting plane. The rear of EUT, including peripherals aligned and flushed with rear of tabletop. All other surfaces of tabletop were at least 80cm from any other grounded conducting surface. EUT was located 80cm from a Line Impedance Stabilization Network (LISN)/ Artificial mains Network (AMN) and excess AC cable was bundled in center.

For the tests on EUT with other peripherals (as a whole system)

I/O cables that were connected to the peripherals were bundled in center. They were folded back and forth forming a bundle 30cm to 40cm long and were hanged at a 40cm height to the ground plane. All unused 50ohm connectors of the LISN(AMN) were resistivity terminated in 50ohm when not connected to the measuring equipment.

The AC Mains Terminal Continuous disturbance Voltage has been measured with the EUT in a Semi Anechoic Chamber. The EUT was connected to a LISN (AMN).

An overview sweep with peak detection has been performed.

The test results and limit are rounded off to one decimal place, so some differences might be observed.

Detector : QP and AV
Measurement range : 0.15-30MHz
Test data : APPENDIX
Test result : Pass

UL Japan, Inc.

Head Office EMC Lab.

4383-326 Asama-cho, Ise-shi, Mie-ken 516-0021 JAPAN

Telephone : +81 596 24 8116

Facsimile : +81 596 24 8124

SECTION 6: Radiated Spurious Emission

Test Procedure

It was measured based on "2. Radiated emission test" of "Guidance on Measurement of Digital Transmission Systems Operating under Section 15.247".

EUT was placed on a urethane platform of nominal size, 0.5m by 1.0m, raised 0.8m above the conducting ground plane. The Radiated Electric Field Strength has been measured in a Semi Anechoic Chamber with a ground plane.

The height of the measuring antenna varied between 1 and 4m and EUT was rotated a full revolution in order to obtain the maximum value of the electric field strength.

The measurements were performed for both vertical and horizontal antenna polarization with the Test Receiver, or the Spectrum Analyzer.

The measurements were made with the following detector function of the test receiver and the Spectrum analyzer (in linear mode).

The test was made with the detector (RBW/VBW) in the following table.

When using Spectrum analyzer, the test was made with adjusting span to zero by using peak hold.

Test Antennas are used as below;

Frequency	Below 30MHz	30MHz to 300MHz	300MHz to 1GHz	Above 1GHz
Antenna Type	Loop	Biconical	Logperiodic	Horn

In any 100kHz bandwidth outside the restricted band in which the spread spectrum intentional radiator is operating, the radio frequency power that is produced by the intentional radiator confirmed 20dB below that in the 100kHz bandwidth within the band that contains the highest level of the desired power, based on a radiated measurement.

20dBc was applied to the frequency over the limit of FCC 15.209 / Table 5 of RSS-Gen 7.2.5(IC) and outside the restricted band of FCC15.205 / Table 3 of RSS-Gen 7.2.2 (IC).

Frequency	Below 1GHz	Above 1GHz		20dBc
Instrument used	Test Receiver	Spectrum Analyzer		Spectrum Analyzer
Detector	QP	PK	AV	PK
IF Bandwidth	BW 120kHz(T/R)	RBW: 1MHz VBW: 3MHz	RBW: 1MHz VBW: 10Hz	RBW: 100kHz VBW: 300kHz (S/A)
Test Distance	3m	3m (below 10GHz), 1m*1) (above 10GHz)		3m (below 10GHz), 1m*1) (above 10GHz)

*1) Distance Factor: $20 \times \log(3.0\text{m}/1.0\text{m}) = 9.5\text{dB}$

- The carrier level and noise levels were confirmed at each position of X, Y and Z axes of EUT to see the position of maximum noise, and the test was made at the position that has the maximum noise.

The test results and limit are rounded off to one decimal place, so some differences might be observed.

Measurement range : 30M-25GHz
Test data : APPENDIX
Test result : Pass

UL Japan, Inc.

Head Office EMC Lab.

4383-326 Asama-cho, Ise-shi, Mie-ken 516-0021 JAPAN

Telephone : +81 596 24 8116

Facsimile : +81 596 24 8124

SECTION 7: Antenna Terminal Conducted Tests

Test Procedure

The tests were made with below setting connected to the antenna port.

Test	Span	RBW	VBW	Sweep time	Detector	Trace	Instrument used
6dB Bandwidth	20MHz / 40MHz	100kHz	300kHz	Auto	Peak	Max Hold	Spectrum Analyzer
99% Occupied Bandwidth	Enough width to display 20dB Bandwidth	1 to 3% of Span	Three times of RBW	Auto	Peak	Max Hold	Spectrum Analyzer
Maximum Peak Output Power	-	-	-	Auto	Peak	-	Power Meter (Sensor: 50MHz BW)
Peak Power Density	18MHz / 38MHz	30kHz	100kHz	600sec / 1267sec	Peak	Max Hold	Spectrum Analyzer *1) *2)
Conducted Spurious Emission *3)	Range: 9kHz-150kHz	200Hz	620Hz	Auto	Peak	Max Hold	Spectrum Analyzer
	Range: 150kHz-30MHz	9.1kHz	27kHz				
	Range: 30MHz-25GHz (Less or equal to 5GHz)	100kHz	300kHz				

*1) PSD Option 1 of "Guidance on Measurement of Digital Transmission Systems Operating under Section15.247 ".
 *2) The test was not performed at RBW:3kHz however the measurement is to be performed with RBW:3kHz in the regulation, because, the measurement value with RBW:3kHz is less than the value of RBW:30kHz and the test data met the limit with RBW:30kHz.
 *3) * In the frequency range below 30MHz, RBW was narrowed to separate the noise contents.
 Then, wide-band noise near the limit was checked separately, however the noise was not detected as shown in the chart.
 (9kHz-150kHz:RBW=200Hz, 150kHz-30MHz:RBW=9.1kHz)

The test results and limit are rounded off to two decimals place, so some differences might be observed.

Test data : APPENDIX
Test result : Pass