

# RADIO TEST REPORT

**Test Report No. : 30IE0112-SH-01-B**

**Applicant** : RICOH COMPANY LTD.  
**Type of Equipment** : Color Copier  
**Model No.** : Aficio MP C5501  
**FCC ID** : BBP-RFAPL03  
**Test regulation** : FCC Part15 Subpart C: 2010  
**Test result** : Complied

1. This test report shall not be reproduced in full or partial, without the written approval of UL Japan, Inc.
2. The results in this report apply only to the sample tested.
3. This sample tested is in compliance with the limits of the above regulation.
4. The test results in this test report are traceable to the national or international standards.
5. This test report must not be used by the customer to claim product certification, approval, or endorsement by any agency of the Federal Government.
6. The opinions and the interpretations to the result of the description in this report are outside scopes where UL Japan has been accredited.

**Date of test:** June 25, 28 and 29, 2010

**Tested by:** M. Hosaka  
Makoto Hosaka  
Engineer of EMC Services

A. Hayashi  
Akio Hayashi  
Engineer of EMC Services

**Approved by:** G. Ishiwata  
Go Ishiwata  
Assistant Manager of EMC Service

- The testing in which "Non-accreditation" is displayed is outside the accreditation scopes in UL Japan.  
 There is no testing item of "Non-accreditation".



<b>Table of Contents</b>	<b>Page</b>
<b>1 Applicant information</b>	<b>3</b>
<b>2 Equipment under test (E.U.T.)</b>	<b>3</b>
<b>3 Test specification, procedures and results</b>	<b>4</b>
<b>4 System test configuration</b>	<b>7</b>
<b>5 Conducted emission</b>	<b>9</b>
<b>6 Out of band emissions (Radiated)</b>	<b>10</b>
<b><u>Contents of Appendixes</u></b>	<b>11</b>

## 1 Applicant information

Company Name : RICOH COMPANY LTD.  
Address : 810 Shimoimaizumi, Ebina-shi, Kanagawaken 243-0460, Japan  
Telephone Number : +81-46-292-9152  
Facsimile Number : +81-46-292-9183  
Contact Person : Akihiro Kurosaka

## 2 Equipment under test (E.U.T.)

### 2.1 Identification of E.U.T.

Type of Equipment : Color Copier  
Model No. : Aficio MP C5501  
Serial No. : V9610100004  
Rating : AC120 - 127V, 12A  
Country of Mass-production : China  
Receipt Date of Sample : June 21 2010  
Condition of EUT : Engineering prototype  
(Not for Sale: This sample is equivalent to mass-produced items.)  
Modification of EUT : No Modification by the test lab

### 2.2 Product description

Model No: Aficio MP C5501, referred to as the EUT in this report, is the Color Copier.  
Refer to the Appendix for the difference between the EUT and its similar models.

### Radio Specification

	RFID	Bluetooth
Equipment type	Transceiver	Transceiver
Frequency of operation	13.56MHz	2402-2480MHz
Clock frequency	13.56MHz	16MHz
Type of modulation	ASK 100%	FHSS
Antenna type	Print pattern antenna	Chip antenna
Antenna connector type	None	None
ITU code	A1D	F1D
Operation temperature range	+10 ~ +32 deg. C.	0 ~ +40 deg.C.

#### FCC Part15.31 (e)

Host device (Color Copier) provides the Bluetooth Module with stable power supply, and the power is not changed when voltage of the Color Laser Printer is varied. Therefore, the equipment complies power supply regulation.

#### FCC Part 15.203

The antenna is not removable from the EUT. Therefore, the equipment complies with the antenna requirement of Section 15.203.

#### FCC Part15.247 (i)

Systems operating under the provisions of this section shall be operated in a manner that ensures that the public is not exposed to radio frequency energy levels in excess of the Commission's guidelines. See § 1.1307 (b)(1) of this chapter. Please refer to the application documents of FCC ID: NXXBL-565. Model: BL-565 is the original model of BL-631.

---

**UL Japan, Inc.**

**SHONAN EMC LAB.**

1-22-3 Megumigaoka, Hiratsuka-shi, Kanagawa-ken 259-1220 JAPAN

Telephone: +81 463 50 6400

Facsimile: +81 463 50 6401

### 3 Test specification, procedures and results

#### 3.1 Test specification

Test specification : FCC Part15 Subpart C: 2010, final revised on January 22, 2010  
And effective March 1, 2010

Title : FCC 47CFR Part15 Radio Frequency Device Subpart C Intentional Radiators  
Section 15.207 Conducted limits  
Section 15.209 Radiated emission limits, general requirements  
Section 15.247 Operation within the bands 902-928MHz, 2400-2483.5MHz,  
and 5725-5850MHz

---

***UL Japan, Inc.***

***SHONAN EMC LAB.***

1-22-3 Megumigaoka, Hiratsuka-shi, Kanagawa-ken 259-1220 JAPAN

Telephone: +81 463 50 6400

Facsimile: +81 463 50 6401

### 3.2 Procedures & Results

Item	Test Procedure	Specification	Remarks	Deviation	Worst Margin	Results
Conducted emission	ANSI C63.4:2003 7. AC powerline conducted emission measurements	FCC Section 15.207	-	N/A	6.2dB (0.70414MHz, L1, QP, Tx 2441MHz)	Complied
Carrier frequency separation	FCC Public Notice DA 00-705 & ANSI C63.4:2003 13. Measurement of intentional radiators	FCC Section15.247 (a)(1)	-	Excluded *1	N/A	N/A
20dB bandwidth	FCC Public Notice DA 00-705 & ANSI C63.4:2003 13. Measurement of intentional radiators	FCC Section15.247 (a)(1)	-	Excluded *1		N/A
Number of hopping frequency	FCC Public Notice DA 00-705 & ANSI C63.4:2003 13. Measurement of intentional radiators	FCC Section15.247 (a)(1)(iii)	-	Excluded *1		N/A
Dwell time	FCC Public Notice DA 00-705 & ANSI C63.4:2003 13. Measurement of intentional radiators	FCC Section15.247 (a)(1)(iii)	-	Excluded *1		N/A
Maximum peak output power	FCC Public Notice DA 00-705 & ANSI C63.4:2003 13. Measurement of intentional radiators	FCC Section15.247 (b)(1)	-	Excluded *1		N/A
Spurious emission	FCC Public Notice DA 00-705 & ANSI C63.4:2003 13. Measurement of intentional radiators	FCC Section15.247 (d)	Conducted	Excluded *1		N/A
Spurious emission & Band edge compliance	FCC Public Notice DA 00-705 & ANSI C63.4:2003 13. Measurement of intentional radiators	FCC Section15.209 & Section15.247 (d)	Radiated	N/A		4.1dB (2658.000MHz, Vertical, Tx 2402MHz )

\*1) These items were tested previously with Bluetooth module, BL-565 alone (FCC ID: NXXBL-565). The results were described in the test report, G0M20103-4306-T-47 published by ELECTRONIC TECHNOLOGY SYSTEM DR. GENZ GMBH (ETS). The Bluetooth Compact Flash Card BL-565 has been certificated on October 25, 2002. After then Change in identification based on FCC Section 2.933 was applied and the changes were model No., trade name and FCC ID. Refer to the information on the FCC web site. (New FCC ID: NXXBL-631)

\*2) Test results for RFID Module were described in the test report 30IE0112-SH-01-A.

\*3) The test has been performed for co-location operation.

Note: UL Japan's EMI Work Procedures No.QPM05 and QPM15.

### 3.3 Addition to standard

Other than above, no addition, exclusion nor deviation has been made from the standard.

**UL Japan, Inc.**

**SHONAN EMC LAB.**

1-22-3 Megumigaoka, Hiratsuka-shi, Kanagawa-ken 259-1220 JAPAN

Telephone: +81 463 50 6400

Facsimile: +81 463 50 6401

### 3.4 Uncertainty

The following uncertainties have been calculated to provide a confidence level of 95% using a coverage factor k=2.

Item	Frequency range	No.1 SAC <sup>*1</sup> /SR <sup>*2</sup> (±)	No.2 SAC/SR (±)	No.3 SAC/SR (±)
Conducted emission (AC Mains) AMN/LISN	9kHz-150kHz	3.7 dB	3.1 dB	3.5 dB
	150kHz-30MHz	3.0 dB	2.6 dB	3.1 dB
Radiated emission (Measurement distance: 3m)	9kHz-30MHz	3.4 dB	2.7 dB	3.4 dB
	30MHz-300MHz	4.6 dB	4.5 dB	4.9 dB
	300MHz-1GHz	4.5 dB	4.6 dB	5.1 dB
	1GHz-13GHz	3.9 dB	3.9 dB	4.0 dB
Radiated emission (Measurement distance: 1m)	13GHz-18GHz	4.8 dB	4.8 dB	4.8 dB
	18GHz-40GHz	4.2 dB	4.2 dB	4.2 dB

\*1: SAC=Semi-Anechoic Chamber

\*2: SR= Shielded Room is applied besides radiated emission

#### Conducted Emission Test

The data listed in this test report has enough margin, more than site margin.

#### Radiated Emission Test

The data listed in this test report has enough margin, more than site margin.

### 3.5 Test location

UL Japan, Inc. Shonan EMC Lab.

1-22-3, Megumigaoka, Hiratsuka-shi, Kanagawa-ken 259-1220 JAPAN

Telephone number : +81 463 50 6400

Facsimile number : +81 463 50 6401

JAB Accreditation No. : RTL02610

No.1/ No.2/ No.3 anechoic chamber has been fully described in a report submitted to FCC office, and accepted on April 17, 2009 (Registration No.: 697847).

IC Registration No. : 2973D-1 (No1 Semi anechoic chamber)

2973D-2 (No2 Semi anechoic chamber)

2973D-3 (No3 Semi anechoic chamber)

Test room	Width x Depth x Height (m)	Test room	Width x Depth x Height (m)
No.1 Semi-anechoic chamber	20.6 x 11.3 x 7.65 Maximum measurement distance: 10m	No.1 Shielded room	6.8 x 4.1 x 2.7
No.2 Semi-anechoic chamber	20.6 x 11.3 x 7.65 Maximum measurement distance: 10m	No.2 Shielded room	6.8 x 4.1 x 2.7
No.3 Semi-anechoic chamber	12.7 x 7.7 x 5.35 Maximum measurement distance: 5m	No.3 Shielded room	6.3 x 4.7 x 2.7
No.4 Semi-anechoic chamber	8.1 x 5.1 x 3.55	No.4 Shielded room	4.4 x 4.7 x 2.7
		No.5 Shielded room	7.8 x 6.4 x 2.7
		No.6 Shielded room	7.8 x 6.4 x 2.7

### 3.6 Test Configuration Photographs, Data of EMI test and Test instruments

Refer to APPENDIX 1 to 3, in this report

**UL Japan, Inc.**

**SHONAN EMC LAB.**

1-22-3 Megumigaoka, Hiratsuka-shi, Kanagawa-ken 259-1220 JAPAN

Telephone: +81 463 50 6400

Facsimile: +81 463 50 6401

## 4 System test configuration

### 4.1 Operating mode

The system was configured in typical fashion (as a customer would normally use it) for testing.

Test item	Operating mode	Tested frequency
Conducted emission	Transmitting (DH5), Payload: PRBS9	2402MHz, 2441MHz, 2480MHz
Spurious emission (Radiated) & Band edge compliance	Transmitting (DH5), Payload: PRBS9 -Hopping ON/Inquiry -Hopping OFF	Spurious emission: 2402MHz, 2441MHz, 2480MHz Band edge compliance:
	Transmitting (DH5), Payload: PRBS9	2402MHz, 2480MHz

Software for testing: D0895563\_BT (Rev: 0.071+)

Power setting value: 0x1D

Above setting of software is the worst case. Any conditions under the normal use do not exceed the condition of setting.

\*Remarks: Test was not performed at AFH mode, because the decrease of number of channel (min: 20ch) at AFH mode does not influence on the output power and bandwidth of the EUT. The EUT has no EDR mode.

\* RFID is also run into Transmitting mode.

Test item	Operating mode	Tested frequency
All items	Transmitting (ASK), 26byte Mirror modulation from lower bit -> AM modulation 0x00, 0x00, 0xB3, 0x75, 0xB0, 0x00, 0x00, 0x80, 0x01, 0xff, 0xfe, 0x01, 0x23, 0x45, 0x67, 0x0B, 0x00, 0x00, 0x00, 0x00, 0x00, 0x00, 0x00, 0x00, 0x00, 0x00, CRC, CRC	13.56MHz

Software for testing: D0895119 (Rev: 0.09:04)

Above setting of software is the worst case. Any conditions under the normal use do not exceed the condition of setting.

Four RFID modules which have the same specification are mounted in the equipment and they don't have simultaneous transmitting function. They were previously checked and the one in which the maximum emission occurred was chosen. ID tag was mounted in the Toner bottle inside of the EUT to communicate with each module.

### 4.2 Configuration and peripherals

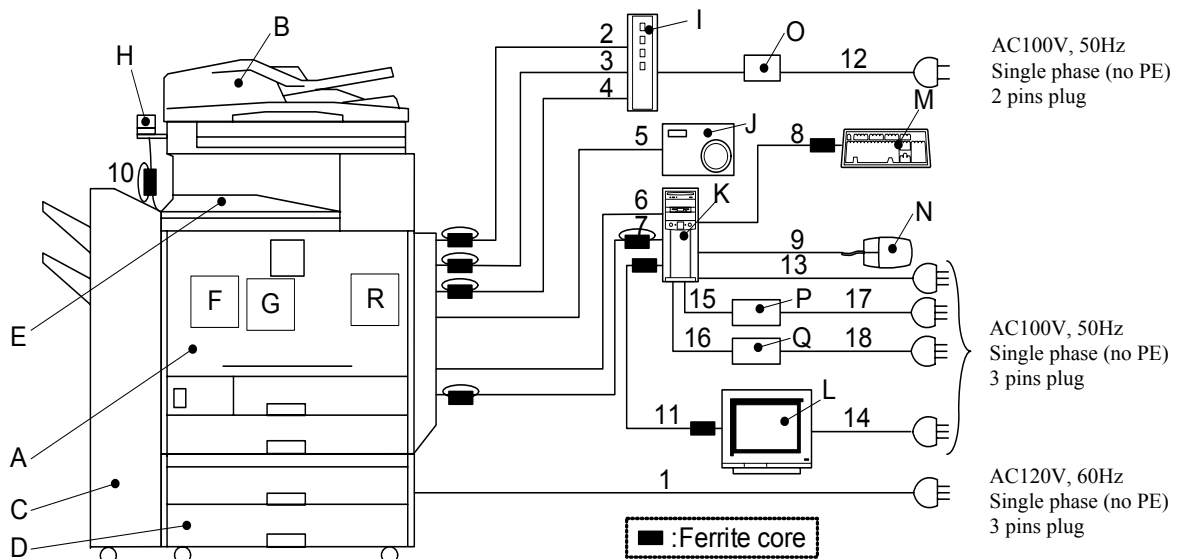

\* Test data was taken under worse case conditions.

**UL Japan, Inc.**

**SHONAN EMC LAB.**

1-22-3 Megumigaoka, Hiratsuka-shi, Kanagawa-ken 259-1220 JAPAN

Telephone: +81 463 50 6400

Facsimile: +81 463 50 6401

**Description of EUT and support equipment**

No.	Item	Model number	Serial number	Manufacturer	Remark
	<b>Color Copier</b>				EUT. This consists of A~H.
A	Color Copier	Aficio MP C5501	V9610100004	RICOH	
B	Document feeder	DF3010	3L39-208679	RICOH	
C	Booklet Finisher	Finisher SR3020	3L41-131436	RICOH	
D	Paper Bank	Paper Feed Unit PB3100	3M58-208447	RICOH	
E	Bridge Unit	Bridge Unit BU3030	3M36-132275	RICOH	
F	RF-ID part	RFID:RW D0895177	9C9065	RICOH	
G	Media Slot	Type 12	3M95-110849	RICOH	
H	Telephone Handset	Hand Set Type 1018	C036/1184 6443A	RICOH	
I	Telephone Exchanger	HP-208	8400066d	TAKACOM	Support equipment.
J	Digital Camera	Caplio R1	00117102	RICOH	Support equipment.
K	Personal Computer	OPTIPLEX 755	CGWWDBX	DELL	Support equipment.
L	LCD Monitor	E153FPb	CN-0C5378-46 633-589-44GU	DELL	Support equipment.
M	Keyboard	L100	CN0RH657658 9082Q01LV	DELL	Support equipment.
N	Mouse	MOC5U0	G1E025EP	DELL	Support equipment.
O	AC Adaptor	AC-HP2800	P1TT00000560	Nishinohon Denshi	Support equipment.
P	Modem	ME3314B	6K07040	OMRON	Support equipment.
Q	Printer	BJ F600	-	Canon	Support equipment.
R	Bluetooth Module	BL-631	81000039	BRAIN BOXES LIMITED	FCC ID: NXXBL-631

\*1) RFID modules are installed in the Color Copier.

**List of cables used**

No.	Name	Length (m)	Shield		Remarks
			Cable	Connector	
1	AC power cable	2.5	Unshielded	Unshielded	-
2	Modular cable (1)	2	Unshielded	Unshielded	With a ferrite core (2 turns, K3 NF-75(N)BK0, FERRICO) at facsimile side.
3	Modular cable (2)	2	Unshielded	Unshielded	With a ferrite core (2 turns, K3 NF-75(N)BK0, FERRICO) at facsimile side.
4	Modular cable (2)	2	Unshielded	Unshielded	With a ferrite core (2 turns, K3 NF-75(N)BK0, FERRICO) at facsimile side.
5	USB cable (1)	3	Shield	Shield	-
6	USB cable (2)	3	Shield	Shield	-
7	LAN cable	3	Unshielded	Unshielded	With a ferrite core (2 turns, RFC-13, KG) at EUT side.
8	Keyboard cable	2	Unshielded	Unshielded	-
9	Mouse cable	1.8	Unshielded	Unshielded	-
10	Modular cable (3)	0.5	Unshielded	Unshielded	With a ferrite core (2 turns, RFC-8, KG) at EUT side.
11	RGB cable	1.5	Shielded	Shielded	-
12	AC power cable	1.5	Unshielded	Unshielded	-
13	AC power cable	1.5	Unshielded	Unshielded	-
14	AC power cable	1.5	Unshielded	Unshielded	-
15	COM Cable	1.8	Shielded	Shielded	-
16	Printer Cable	3	Shielded	Shielded	-
17	AC Power Cable	1	Unshielded	Unshielded	-
18	AC power cable	1	Unshielded	Unshielded	-

**UL Japan, Inc.**

**SHONAN EMC LAB.**

1-22-3 Megumigaoka, Hiratsuka-shi, Kanagawa-ken 259-1220 JAPAN

Telephone: +81 463 50 6400

Facsimile: +81 463 50 6401



## 5 Conducted emissions

### 5.1 Operating environment

The test was carried out in No.3 Shielded room.

Temperature : See test data  
Humidity : See test data

### 5.2 Test configuration

EUT was placed on a carpet for insulation above the ground plane. EUT was set up typical spacing for the other equipment. EUT was located 80cm from LISN and excess AC cable was bundled in center. I/O cables that were connected to the peripherals were bundled in center. I/O cables that were connected to the peripherals were bundled in center. They were folded back and for the forming a bundle 30cm to 40cm long and were hanged at a 40cm height to the ground plane.

Each EUT current-carrying power lead, except the ground (safety) lead, was individually connected through a LISN to the input power source. All unused 50Ω connectors of the LISN were resistively terminated in 50Ω when not connected to the measuring equipment.

Photographs of the set up are shown in Appendix 1.

### 5.3 Test conditions

Frequency range : 0.15 - 30MHz  
EUT position : Floor standing

### 5.4 Test procedure

The AC Mains Terminal Continuous disturbance Voltage had been measured with the EUT within a screened room. The EUT was connected to a Line Impedance Stabilization Network (LISN).

An overview sweep with peak detection has been performed.

The measurements had been performed with a quasi-peak detector and if required, an average detector.

The conducted emission measurements were made with the following detector of the test receiver.

Detector Type : Quasi-Peak/ Average  
IF Bandwidth : 9kHz

### 5.5 Results

Summary of the test results : Pass

---

**UL Japan, Inc.**

**SHONAN EMC LAB.**

1-22-3 Megumigaoka, Hiratsuka-shi, Kanagawa-ken 259-1220 JAPAN

Telephone: +81 463 50 6400

Facsimile: +81 463 50 6401

---

## 6 Out of band emissions (Radiated)

### 6.1 Operating environment

The test was carried out in No.3 Semi-anechoic chamber.

### 6.2 Test configuration

EUT was placed on a carpet for insulation above the conducting ground plane to prevent the reflection influence. The configuration was set in accordance with ANSI C63.4: 2003. Photographs of the set up are shown in Appendix 1.

### 6.3 Test conditions

Frequency range : 30MHz - 26GHz  
Test distance : 3m (30MHz-13GHz), 1m (13-26GHz)

### 6.4 Test procedure

The Radiated Electric Field Strength intensity has been measured with a ground plane and at a distance of 3m or 1m. The measuring antenna height was varied between 1 and 4m and EUT was rotated a full revolution in order to obtain the maximum value of the electric field intensity. The measurements were performed for both vertical and horizontal antenna polarization. Measurements were performed with QP, PK, and AV detector.

The radiated emission measurements were made with the following detector function of the test receiver.

When using Spectrum analyzer, the test was made with adjusting span to zero by using peak hold.

Frequency	Below 1GHz	Above 1GHz
Instrument used	Test Receiver	Spectrum Analyzer
Detector IF Bandwidth	QP: BW 120kHz	PK: RBW: 1MHz/VBW: 1MHz AV RBW: 1MHz/VBW: 270Hz (To see data at page 23) : 10Hz (No pulse emission)
Measuring antenna	Biconical (30-299.99MHz) Logperiodic (300MHz-1GHz)	Horn

### 6.5 Band edge

Band edge level at 2400MHz is less than 20dB of peak point of the carrier. Band edge level at 2390MHz and 2483.5MHz is below the limits of FCC 15.209. Refer to the data of Radiated emission.

### 6.6 Results

Summary of the test results : Pass \*No noise was detected above the 5<sup>th</sup> order harmonics.

---

**UL Japan, Inc.**

**SHONAN EMC LAB.**

1-22-3 Megumigaoka, Hiratsuka-shi, Kanagawa-ken 259-1220 JAPAN

Telephone: +81 463 50 6400

Facsimile: +81 463 50 6401

### **APPENDIX 1: Photographs of test setup**

Page 12 : Conducted emission

Page 13 : Radiated emission

### **APPENDIX 2: Test data**

Page 14 - 16 : Conducted emission

Page 17 - 23 : Radiated emission

### **APPENDIX 3: Test instruments**

Page 24 : Test instruments

### **APPENDIX 4: Similar model description**

Page 25 : Similar model description

---

***UL Japan, Inc.***

***SHONAN EMC LAB.***

1-22-3 Megumigaoka, Hiratsuka-shi, Kanagawa-ken 259-1220 JAPAN

Telephone: +81 463 50 6400

Facsimile: +81 463 50 6401