



# RADIO TEST REPORT

Test Report No.: 28HE0081-YK-01-G

Applicant : Ricoh Company, Ltd.  
Type of Equipment : Full-color MFP  
Model No. : Aficio MP C5000  
FCC ID : BBP-RFAPL02  
Test regulation : FCC Part15 Subpart C: 2008  
Test result : Complied

1. This test report shall not be reproduced except in full or partial, without the written approval of UL Japan, Inc.
2. The results in this report apply only to the sample tested.
3. This sample tested is in compliance with the limits of the above regulation.
4. The test results in this test report are traceable to the national or international standards.

Date of test: May 19, 21 and 23, 2008

Tested by: T. Arai  
Tatsuya Arai

& F. Matsuo  
Fumiaki Matsuo

Approved by: T. Amamura  
Toyokazu Imamura  
Engineer of Yamakita EMC Lab.

**UL Japan, Inc.**

**YAMAKITA EMC LAB.**

907 Kawanishi, Yamakita-machi, Ashigarakami-gun, Kanagawa-ken, 258-0124 JAPAN

Telephone: +81 465 77 1011

Facsimile: +81 465 77 2112

MF060b (09.01.08)

<b>Table of Contents</b>	<b>Page</b>
<b>1 Applicant information</b>	<b>3</b>
<b>2 Equipment under test (E.U.T.)</b>	<b>3</b>
<b>3 Test specification, procedures and results</b>	<b>4</b>
<b>4 System test configuration</b>	<b>6</b>
<b>5 Conducted emission</b>	<b>8</b>
<b>6 Out of band emissions (Radiated)</b>	<b>9</b>
<b><u>Contents of Appendixes</u></b>	<b>10</b>
<b>APPENDIX 1: Photographs of test setup</b>	<b>11</b>
<b>APPENDIX 2: Test data</b>	<b>13</b>
<b>APPENDIX 3: Test instruments</b>	<b>41</b>
<b>APPENDIX 4: Similar model description</b>	<b>42</b>

---

***UL Japan, Inc.***

***YAMAKITA EMC LAB.***

907 Kawanishi, Yamakita-machi, Ashigarakami-gun, Kanagawa-ken, 258-0124 JAPAN

Telephone: +81 465 77 1011

Facsimile: +81 465 77 2112

MF060b (09.01.08)

## 1 Applicant information

Company Name : Ricoh Company, Ltd.  
 Address : 810 Shimoimaizumi, Ebina-shi, Kanagawa-ken, 243-0460 Japan  
 Telephone Number : +81-46-292-3872  
 Facsimile Number : +81-46-231-9183  
 Contact Person : Shinji Okada

## 2 Equipment under test (E.U.T.)

### 2.1 Identification of E.U.T.

Type of Equipment : Full-color MFP  
 Model No. : Aficio MP C5000  
 Serial No. : 3B51-001011  
 Rating : AC120V±10%, 50/60Hz  
 Country of Mass-production : China  
 Receipt Date of Sample : April 11, 2008  
 Condition of EUT : Production prototype  
 (Not for Sale: This sample is equivalent to mass-produced items.)  
 Modification of EUT : No modification by the test lab.

### 2.2 Product description

Model: Aficio MP C5000 (referred to as the EUT in this report) is a Full-color MFP.  
 Refer to the Appendix for the difference between the EUT and its similar models.

	RFID	Wireless LAN
Equipment type	Transceiver	Transceiver
Frequency of operation	13.56MHz	[11b/g] 2412-2462MHz [11a] 5180-5320MHz *1)
Clock frequency	13.56MHz	11MHz, 20MHz
Type of modulation	ASK 100%	IEEE802.11a: OFDM (BPSK, QPSK, 16QAM, 64QAM) IEEE802.11b: DSSS (DBPSK, DQPSK, CCK) IEEE802.11g: OFDM (BPSK, QPSK, 16QAM, 64QAM)
Antenna type	Print pattern antenna	Monopole antenna Antenna 1: Transmitting & Receiving Antenna 2: Receiving only
Antenna connector type	None	None
ITU code	A1D	D1D, G1D
Operation temperature range	+10 ~ +32 deg. C.	0 ~ +65 deg.C.

\*1) Refer to 28HE0081-YK-01-H, FCC part 15E (FCC 15.407) report.

\*FCC Part15.31 (e)

Host device (Full-color MFP) provides the Wireless LAN Module with stable power supply, and the power is not changed when voltage of the Full-color MFP is varied. Therefore, the equipment complies power supply regulation.

\*FCC Part15.203

It is impossible for end users to replace the antenna, because the antenna is mounted on the board integrally. Therefore, the equipment complies with the antenna requirement of Section 15.203.

FCC Part15.247 (i)

(i) Systems operating under the provisions of this section shall be operated in a manner that ensures that the public is not exposed to radio frequency energy levels in excess of the Commission's guidelines. See § 1.1307 (b)(1) of this chapter. Please refer to the application documents of FCC ID: BBP-WLRWL541.

**UL Japan, Inc.**

**YAMAKITA EMC LAB.**

907 Kawanishi, Yamakita-machi, Ashigarakami-gun, Kanagawa-ken, 258-0124 JAPAN

Telephone: +81 465 77 1011 Facsimile: +81 465 77 2112

MF060b (09.01.08)

### 3 Test specification, procedures and results

#### 3.1 Test specification

Test specification : FCC Part15 Subpart C: 2008, final revised on May 19, 2008  
 Title : FCC 47CFR Part15 Radio Frequency Device Subpart C Intentional Radiators  
 Section 15.207 Conducted limits  
 Section 15.209 Radiated emission limits, general requirements  
 Section 15.247 Operation within the bands 902-928MHz, 2400-2483.5MHz,  
 and 5725-5850MHz

#### 3.2 Procedures & results

Item	Test Procedure	Specification	Remarks	Deviation	Worst Margin	Results
Conducted Emission	ANSI C63.4:2003 7. AC powerline conducted emission measurements	FCC 15.107(a) & 207	-	N/A	10.0dB (13.8827MHz, L1, Tx 2412MHz, AV)	Complied
6dB Bandwidth	ANSI C63.4:2003 13. Measurement of intentional radiators	FCC 15.247 (a)(2) & 15.209	-	Excluded *1)	-	N/A
Maximum Peak Output Power	ANSI C63.4:2003 13. Measurement of intentional radiators	FCC 15.247 (b)(3) & 15.209	-	Excluded *1)		N/A
Out of Band Emission	ANSI C63.4:2003 13. Measurement of intentional radiators	FCC 15.247 (d)	Conducted	Excluded *1)		N/A
Out of Band Emission & Restricted Band Edges	ANSI C63.4:2003 13. Measurement of intentional radiators	FCC 15.109, 15.247 (d) & 15.209	Radiated	N/A	0.4dB (2400.00MHz, Vertical, Tx 2412MHz)	Complied
Power Density	ANSI C63.4:2003 13. Measurement of intentional radiators	FCC 15.247 (e) & 15.209	-	Excluded *1)	-	N/A

Note: UL Japan's EMI Work Procedures No.QPM05 and QPM15.  
 These tests were also referred to "Guidance on Measurement for Digital Transmission Systems Section15.247".

\*1) These items were tested previously with Wireless LAN Module alone. The results were described in the test report 27IE0337-YK-A, published by UL Japan, Inc. The Wireless LAN Module has been certificated on December 17, 2007.

\*2) Test results for RFID Module were described in the test report 28HE0081-YK-01-D.

\*3) The test has been performed for co-location operation.

#### 3.3 Addition to standard

Other than above, no addition, exclusion nor deviation has been made from the standard.

**UL Japan, Inc.**

**YAMAKITA EMC LAB.**

907 Kawanishi, Yamakita-machi, Ashigarakami-gun, Kanagawa-ken, 258-0124 JAPAN

Telephone: +81 465 77 1011 Facsimile: +81 465 77 2112

MF060b (09.01.08)

### 3.4 Uncertainty

The following uncertainties have been calculated to provide a confidence level of 95% using a coverage factor k=2.

	No.1 open site (±)	No.2 open site (±)	No.1 anechoic chamber (±)
<b>Conducted emission</b>			
150kHz-30MHz	2.8 dB	2.8 dB	2.8 dB
<b>Radiated emission (3m)</b>			
30-300MHz	4.5 dB	4.4 dB	4.5 dB
300-1000MHz	4.3 dB	4.3 dB	4.3 dB
1GHz<	5.7 dB	5.7 dB	5.7 dB

#### Conducted Emission Test

The data listed in this test report has enough margin, more than site margin.

#### Radiated Emission Test

The data listed in this report meets the limits unless the uncertainty is taken into consideration.

### 3.5 Test location

UL Japan, Inc. Yamakita EMC Lab.

907, Kawanishi, Yamakita-machi, Ashigarakami-gun, Kanagawa-ken 258-0124 JAPAN

Telephone number : +81 465 77 1011

Facsimile number : +81 465 77 2112

NVLAP Lab. code : 200441-0

No. 1 test site has been fully described in a report submitted to FCC office, and accepted on August 26, 2005 (Registration No.: 95486).

IC Registration No. : 2973B-1

No. 2 test site has been fully described in a report submitted to FCC office, and accepted on February 27, 2008 (Registration No.: 466226).

IC Registration No. : 2973B-3

No. 1 anechoic chamber has been fully described in a report submitted to FCC office, and accepted on November 2, 2005 (Registration No.: 95967).

IC Registration No. : 2973B-2

Test room	Width x Depth x Height (m)	Test room	Width x Depth x Height (m)
No.1 shielded room	8.0 x 5.0 x 2.5	No.1 Semi-anechoic chamber	10.0 x 7.5 x 5.7
No.2 shielded room	5.0 x 4.0 x 2.5		
No.3 shielded room	4.0 x 5.0 x 2.7		

Open test site	Maximum measurement distance
No.1 open test site	30m
No.2 open test site	10m

**UL Japan, Inc.**

**YAMAKITA EMC LAB.**

907 Kawanishi, Yamakita-machi, Ashigarakami-gun, Kanagawa-ken, 258-0124 JAPAN

Telephone: +81 465 77 1011 Facsimile: +81 465 77 2112

MF060b (09.01.08)

## 4 System test configuration

### 4.1 Operation mode

The system was configured in typical fashion (as a customer would normally use it) for testing.

Test item	Operating mode	Tested frequency
Conducted emission	Transmitting (IEEE802.11b), 11Mbps	2412MHz, 2437MHz, 2462MHz
Spurious emission	Transmitting (IEEE802.11g), 54Mbps	
Restricted band edge	Transmitting (IEEE802.11b), 11Mbps	2412MHz, 2462MHz
	Transmitting (IEEE802.11g), 54Mbps	

\* RFID is also run into Transmitting mode.

Test item	Operating mode	Tested frequency
All items	Transmitting (ASK), 26byte Mirror modulation from lower bit -> AM modulation 0x00, 0x00, 0xB3, 0x75, 0xB0, 0x00, 0x00, 0x80, 0x01, 0xff, 0xfe, 0x01, 0x23, 0x45, 0x67, 0x0B, 0x00, 0x00, 0x00, 0x00, 0x00, 0x00, 0x00, 0x00, 0x00, CRC, CRC	13.56MHz

Four RFID modules which have the same specification are mounted in the equipment and they don't have simultaneous transmitting function. They were previously checked and the one in which the maximum emission occurred was chosen. ID tag was mounted in the ribbon inside of the EUT to communicate with each module.

The EUT exercise program used during testing was designed to exercise the various system components in a manner similar to typical use.

### 4.2 Configuration of tested system

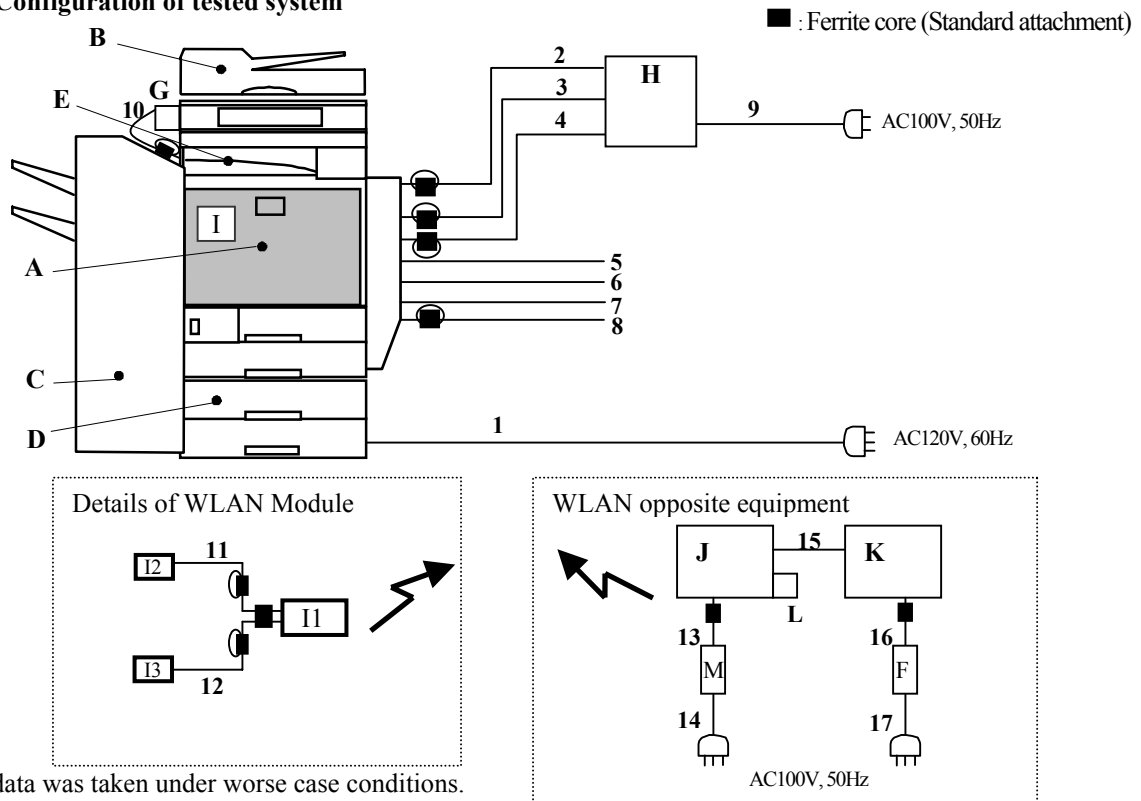

UL Japan, Inc.

YAMAKITA EMC LAB.

907 Kawanishi, Yamakita-machi, Ashigarakami-gun, Kanagawa-ken, 258-0124 JAPAN

Telephone: +81 465 77 1011 Facsimile: +81 465 77 2112

MF060b (09.01.08)

**Description of EUT and support equipments**

No.	Item	Model number	Serial number	Manufacturer	Remark
A	Full-color MFP	Aficio MP C5000	3B51-001011	RICOH	EUT *1)
B	Document Feeder	DF3010	3L39-135641	RICOH	-
C	Booklet Finisher	SR790	J1077608455	RICOH	-
D	Paper Bank	PB3040	D351-000039	RICOH	-
E	Bridge Unit	BU3030	BU10005	RICOH	-
F	AC Adaptor	ADP-18PB	PZT0649769006	DELTH	-
G	Hand Unit	AF-33	C075	RICOH	-
H	Telephone Exchanger (PBX)	NT-102MK II	-	Newtech	-
I1	WLAN Module	R-WL54MN	80200059	RICOH	FCC ID: BBP-WLRWL_541
I2	Antenna 1	ANT0602-WMFW/N-AB	-	NISSEI ELECTRIC	-
I3	Antenna 2	ANT0602-WMFW/N-AB	-	NISSEI ELECTRIC	-
J	Note PC	2525-5AJ	LU-D0528	IBM	-
K	Access Point	AIR-AP1131AG-P-K9	FHK1102C020	Cisco	-
L	WLAN Card	WLI-CB-AMG54	76601955137471	BUFFALO	-
M	AC Adaptor	02K6810	-	IBM	-

\*1) RFID modules are installed in the Full-color MFP.

**List of cables used**

No.	Name	Length (m)	Shield		Remark
			Cable	Connector	
1	AC power cable	2.5	Unshielded	Unshielded	-
2	Modular cable (1)	2.0	Unshielded	Unshielded	-
3	Modular cable (2)	2.0	Unshielded	Unshielded	-
4	Modular cable (3)	2.0	Unshielded	Unshielded	-
5	USB cable (1)	2.5	Shielded	Shielded	-
6	USB cable (2)	2.5	Shielded	Shielded	-
7	USB cable (3)	2.5	Shielded	Shielded	-
8	LAN cable	3.0	Unshielded	Unshielded	-
9	AC power cable	1.7	Unshielded	Unshielded	-
10	Hand Unit cable	0.7	Unshielded	Unshielded	-
11	Antenna cable	0.9	Shielded	Shielded	-
12	Antenna cable	0.9	Shielded	Shielded	-
13	DC cable	1.8	Unshielded	Unshielded	-
14	AC cable	1.0	Unshielded	Unshielded	-
15	LAN cable	0.4	Unshielded	Unshielded	-
16	DC cable	1.8	Unshielded	Unshielded	-
17	AC cable	2.4	Unshielded	Unshielded	-

**UL Japan, Inc.**

**YAMAKITA EMC LAB.**

907 Kawanishi, Yamakita-machi, Ashigarakami-gun, Kanagawa-ken, 258-0124 JAPAN

Telephone: +81 465 77 1011

Facsimile: +81 465 77 2112

MF060b (09.01.08)

## 5 Conducted emissions

### 5.1 Operating environment

The test was carried out in No.1 anechoic chamber.

### 5.2 Test configuration

EUT was placed on a carpet for insulation above the ground plane. EUT was located 80cm from LISN and excess AC cable was bundled in center. The PBX was set up under the worst case. Photographs of the set up are shown in Appendix 1.

### 5.3 Test conditions

Frequency range : 0.15 - 30MHz

### 5.4 Test procedure

The EUT was connected to a LISN (AMN). An overview sweep with peak detection has been performed. The Conducted emission measurements were made with the following detector function of the test receiver.

Detector: QP/AV

IF Bandwidth: 10kHz

### 5.5 Results

Summary of the test results : Pass

Date : May 23, 2008 Test engineer : Fumiaki Matsuo



---

## 6 Out of band emissions (Radiated)

### 6.1 Operating environment

The test was carried out in No.1 anechoic chamber.

### 6.2 Test configuration

EUT was placed on a wooden platform of nominal size, 1.0m by 1.0m, raised 10cm above the conducting ground plane to set the RFID module 80cm above the ground plane. The PBX was set up under the worst case. Photographs of the set up are shown in Appendix 1.

### 6.3 Test conditions

Frequency range : 30MHz - 26GHz  
Test distance : 3m (30MHz-18GHz), 1m (18-26GHz)

### 6.4 Test procedure

The Radiated Electric Field Strength intensity has been measured with a ground plane and at a distance of 3m or 1m. The measuring antenna height was varied between 1 and 4m and EUT was rotated a full revolution in order to obtain the maximum value of the electric field intensity. The measurements were performed for both vertical and horizontal antenna polarization. Measurements were performed with QP, PK, and AV detector.

The radiated emission measurements were made with the following detector function of the test receiver.

When using Spectrum analyzer, the test was made with adjusting span to zero by using peak hold.

Frequency	Below 1GHz	Above 1GHz
Instrument used	Test Receiver	Spectrum Analyzer
Detector IF Bandwidth	QP: BW 120kHz	PK: RBW: 1MHz/VBW: 1MHz AV RBW: 1MHz/VBW: 10Hz
Measuring antenna	Biconical (30-299.99MHz) Logperiodic (300MHz-1GHz)	Horn

### 6.5 Band edge

Band edge level at 2390MHz, 2400MHz and 2483.5MHz is below the limits of FCC 15.209. Refer to the data.

### 6.6 Results

Summary of the test results : Pass  
No noise was detected above the 5<sup>th</sup> order harmonics.

Date : May 19 and 21, 2008 Test engineer : Tatsuya Arai

---

**UL Japan, Inc.**

**YAMAKITA EMC LAB.**

907 Kawanishi, Yamakita-machi, Ashigarakami-gun, Kanagawa-ken, 258-0124 JAPAN

Telephone: +81 465 77 1011 Facsimile: +81 465 77 2112

MF060b (09.01.08)

### **APPENDIX 1: Photographs of test setup**

Page 11 : Conducted emission

Page 12 : Radiated emission

### **APPENDIX 2: Test Data**

Page 13 - 22 : Conducted emission

Page 23 - 40 : Out of band emissions (Radiated)

### **APPENDIX 3: Test instruments**

Page 41 : Test instruments

### **APPENDIX 4: Similar model description**

Page 42 : Similar model description

---

***UL Japan, Inc.***

***YAMAKITA EMC LAB.***

907 Kawanishi, Yamakita-machi, Ashigarakami-gun, Kanagawa-ken, 258-0124 JAPAN

Telephone: +81 465 77 1011 Facsimile: +81 465 77 2112

MF060b (09.01.08)