



Test Report No:
2410654R-RFUSV03S-A

TEST REPORT FCC Rules & Regulations

Product Name	DIGITAL CAMERA
Brand Name	RICOH
Model No.	R07010
FCC ID	BBP-R07010
Applicant's Name / Address	Ricoh Company Ltd 2-7-1 Izumi Ebina Kanagawa, 243-0460 Japan
Manufacturer's Name	Ricoh Company, Ltd.
Test Method Requested, Standard	FCC CFR Title 47 Part 15 Subpart E Section 15.407 ANSI C63.10-2013
Verdict Summary	IN COMPLIANCE
Documented By Ida Tung	<i>Ida Tung</i>
Tested By Ivan Chuang	<i>Ivan Chuang</i>
Approved By Steven Tsai	<i>Steven Tsai</i>
Date of Receipt	2024/01/23
Date of Issue	2024/10/09
Report Version	V1.0

INDEX

	page
Competences and Guarantees.....	4
General Conditions.....	4
Revision History.....	5
Summary of Test Result.....	6
1. General Information	7
1.1. EUT Description.....	7
1.2. EUT Information.....	8
1.3. Testing Location Information.....	8
1.4. Measurement Uncertainty.....	9
1.5. List of Test Equipment	10
2. Test Configuration of EUT.....	11
2.1. Test Condition	11
2.2. Test Frequency Mode	11
2.3. Duty Cycle.....	12
2.4. Measurement Configuration	14
2.5. Tested System Details	15
2.6. Configuration of tested System	15
2.7. EUT Operating Procedures	15
3. AC Power Line Conducted Emission.....	16
3.1. Test Setup.....	16
3.2. Test Limit.....	16
3.3. Test Procedure.....	16
3.4. Test Result of AC Power Line Conducted Emission.....	16
4. Emission Bandwidth.....	17
4.1. Test Setup.....	17
4.2. Test Limit.....	17
4.3. Test Procedure.....	17
4.4. Test Result of Emission Bandwidth	17
5. Maximum Conducted Output Power.....	18
5.1. Test Setup.....	18
5.2. Test Limit.....	18
5.3. Test Procedure.....	18
5.4. Test Result of Maximum Conducted Output Power.....	18
6. Maximum Power Spectral Density.....	19
6.1. Test Setup.....	19
6.2. Test Limit.....	19

6.3.	Test Procedure.....	19
6.4.	Test Result of Maximum Power Spectral Density.....	19
7.	Transmitter Radiated Spurious Emission.....	20
7.1.	Test Setup	20
7.2.	Test Limit.....	21
7.3.	Test Procedure.....	22
7.4.	Test Result of Transmitter Radiated Spurious Emission	22
Appendix A. Test Result of AC Power Line Conducted Emission		
Appendix B. Test Result of Emission Bandwidth		
Appendix C. Test Result of Maximum Conducted Output Power		
Appendix D. Test Result of Maximum Power Spectral Density		
Appendix E. Test Result of Transmitter Radiated Spurious Emission		
Appendix F. Test Setup Photograph		

Competences and Guarantees

DEKRA is a testing laboratory competent to carry out the tests described in this report.

In order to assure the traceability to other national and international laboratories, DEKRA has a calibration and maintenance program for its measurement equipment.

DEKRA guarantees the reliability of the data presented in this report, which is the result of the measurements and the tests performed to the item under test on the date and under the conditions stated in the report and it is based on the knowledge and technical facilities available at DEKRA at the time of performance of the test.

DEKRA is liable to the client for the maintenance of the confidentiality of all information related to the item under test and the results of the test.

The results presented in this Test Report apply only to the particular item under test established in this document.

IMPORTANT: No parts of this report may be reproduced or quoted out of context, in any form or by any means, except in full, without the previous written permission of DEKRA.

General Conditions

1. The test results relate only to the samples tested.
2. The test results shown in the test report are traceable to the national/international standard through the calibration report of the equipment and evaluated measurement uncertainty herein.
3. This report must not be used to claim product endorsement by TAF or any agency of the government.
4. The test report shall not be reproduced without the written approval of DEKRA Testing and Certification Co., Ltd.
5. Measurement uncertainties evaluated for each testing system and associated connections are given here to provide the system information for reference. Compliance determinations do not take into account measurement uncertainties for each testing system, but are based on the results of the compliance measurement.

Revision History

Version	Description	Issued Date
V1.0	Initial issue of report	2024/10/09

Summary of Test Result

Report Clause	Test Items	Result (PASS/FAIL)	Remark
3	AC Power Line Conducted Emission	PASS	-
4	Emission Bandwidth	PASS	-
5	Maximum Conducted Output Power	PASS	-
6	Maximum Power Spectral Density	PASS	-
7	Transmitter Radiated Spurious Emission	PASS	-

Comments and Explanations

The declared of product specification for EUT presented in the report are provided by the manufacturer, and the manufacturer takes all the responsibilities for the accuracy of product specification.

1. General Information

1.1. EUT Description

Frequency Range	5150 ~ 5250 MHz 5725 ~ 5850 MHz		
Operating Frequency / Channel Number	IEEE 802.11a/n/ac/ax (20 MHz)	5180 ~ 5240 MHz / 4 Channels 5745 ~ 5825 MHz / 5 Channels	
	IEEE 802.11n/ac/ax (40 MHz)	5190 ~ 5230 MHz / 2 Channels 5755 ~ 5795 MHz / 2 Channels	
	IEEE 802.11ac/ax (80 MHz)	5210 MHz / 1 Channel 5775 MHz / 1 Channel	
Type of Modulation	IEEE 802.11a/n	OFDM-BPSK, QPSK, 16QAM, 64QAM	
	IEEE 802.11ac	OFDM-BPSK, QPSK, 16QAM, 64QAM, 256QAM	
	IEEE 802.11ax	OFDMA-BPSK, QPSK, 16QAM, 64QAM, 256QAM, 1024QAM	

Accessories Information		
No.	Equipment Name	Description
1	Type-C to USB Cable	Shielded, 0.4m

Antenna Information							
Item.	Brand Name	Model No.	Type	Antenna Gain (dBi)		Directional Gain (dBi)	
1	Ability	ALX23M-222AA6-00 (Main)	PIFA	U-NII 1	3.10	U-NII 1	6.16
				U-NII 3	4.00		
		ALX23M-222AA6-00 (Main)		U-NII 1	3.20	U-NII 3	7.01
				U-NII 3	4.00		

Note: The antenna of EUT is conforming to FCC 15.203.

For IEEE 802.11a/n/ac/ax Mode: (2TX, 2RX)

Both Ant. 0 and Ant. 1 can be used as transmitting/receiving antennas.

1.2. EUT Information

EUT Power Type	DC 3.6 V (Power by Battery) / DC 5V, 9V (Power by USB)			
EUT Function	<input checked="" type="checkbox"/>	Point-to-multipoint	<input type="checkbox"/>	Point-to-point
TPC Function	<input type="checkbox"/>	With TPC Function	<input checked="" type="checkbox"/>	Without TPC Function
Beamforming Function	<input type="checkbox"/>	With beamforming	<input checked="" type="checkbox"/>	Without beamforming
Resource Unit of 802.11ax	<input checked="" type="checkbox"/>	Full RU	<input type="checkbox"/>	Partial RU

1.3. Testing Location Information

USA	FCC Designation Number: TW0033
Canada	CAB Identifier Number: TW3023 / Company Number: 26930

Site Description	Accredited by TAF
	Accredited Number: 3023

Test Laboratory	DEKRA Testing and Certification Co., Ltd.
	Linkou Laboratory
Address	No.5-22, Ruishukeng Linkou District, New Taipei City, 24451, Taiwan, R.O.C.
Performed Location	No. 26, Huaya 1st Rd., Guishan Dist., Taoyuan City 333411, Taiwan, R.O.C.
Phone Number	+886-3-275-7255
Fax Number	+886-3-327-8031

Ambient conditions in the laboratory:

Performed Item	Items	Required	Actual	Test Date
AC Power Line Conducted Emission	Temperature (°C)	10~40 °C	25.9 °C	2024/07/12
	Humidity (%RH)	10~90 %	57.0 %	
Radiated Emission	Temperature (°C)	10~40 °C	25.8 °C	2024/05/30~2024/06/06
	Humidity (%RH)	10~90 %	50.0 %	
Conducted Emission	Temperature (°C)	10~40 °C	24.1 °C	2024/06/03-2024/06/28
	Humidity (%RH)	10~90 %	52.0 %	

1.4. Measurement Uncertainty

Uncertainties have been calculated according to the DEKRA internal document with the emissions test results be included in the report. The measurement uncertainties given below are based on a 95% confidence level (based on a coverage factor (k=2)).

Measurement uncertainties evaluated for each testing system and associated connections are given here to provide the system information for reference. Compliance determinations do not take into account measurement uncertainties for each testing system, but are based on the results of the compliance measurement.

Test item	Uncertainty
AC Power Line Conducted Emission	±3.50 dB
Emission Bandwidth	±1580.61 Hz
Maximum Conducted Output Power	Spectrum Analyzer: ±2.13 dB Power Meter: ±1.07 dB
Maximum Power Spectral Density	±2.13 dB
Transmitter Radiated Spurious Emission	9 kHz~30 MHz: ±3.30 dB 30 MHz~1 GHz: ±4.79 dB 1 GHz~18 GHz: ±4.17 dB 18 GHz~40 GHz: ±3.32 dB

1.5. List of Test Equipment

For Conduction Measurements / HY-SR01

	Equipment	Manufacturer	Model No.	Serial No.	Cal. Date	Due Date
V	EMI Test Receiver	R&S	ESR7	101601	2024/06/24	2025/06/23
V	Two-Line V-Network	R&S	ENV216	101306	2024/04/01	2025/03/31
V	Two-Line V-Network	R&S	ENV216	101307	2023/08/17	2024/08/16
V	Coaxial Cable	SUHNER	RG400_BNC	RF001	2024/01/10	2025/01/09

Note:

1. All equipments are calibrated every one year.
2. The test instruments marked with "V" are used to measure the final test results.
3. Test Software Version: e3 230303 dekra V9.

For Conducted Measurements / HY-SR02

	Equipment	Manufacturer	Model No.	Serial No.	Cal. Date	Due Date
V	Spectrum Analyzer	R&S	FSV30	103466	2024/01/05	2025/01/04
V	Peak Power Analyzer	KEYSIGHT	8990B	MY51000539	2024/05/07	2025/05/06
V	Wideband Power Sensor	KEYSIGHT	N1923A	MY59240002	2024/05/08	2025/05/07
V	Wideband Power Sensor	KEYSIGHT	N1923A	MY59240003	2024/05/08	2025/05/07

Note:

1. All equipments are calibrated every one year.
2. The test instruments marked with "V" are used to measure the final test results.
3. Test Software Version: RF Conducted Test Tools R3 V3.0.1.14.

For Radiated Measurements / HY-CB03

	Equipment	Manufacturer	Model No.	Serial No.	Cal. Date	Due Date
V	Loop Antenna	TESEQ	HLA6121	49611	2024/02/23	2025/02/22
V	Bi-Log Antenna	SCHWARZBECK	VULB9168	9168-0675	2023/08/09	2025/08/08
V	Horn Antenna	Com-Power	AH-840	101101	2023/12/04	2025/12/03
V	Horn Antenna	RF SPIN	DRH18-E	210507A18ES	2024/05/15	2025/05/14
V	Pre-Amplifier	SGH	SGH0301-9	20211007-11	2024/01/10	2025/01/09
V	Pre-Amplifier	SGH	PRAMP118	20200701	2024/01/10	2025/01/09
V	Pre-Amplifier	EMCI	EMC05820SE	980310	2024/01/10	2025/01/09
V	Pre-Amplifier	EMCI	EMC184045SE	980369	2024/01/10	2025/01/09
V	Coaxial Cable	EMCI	EMC102-KM-KM-600	1160314	2024/01/10	2025/01/09
V	Coaxial Cable	EMCI	EMC102-KM-KM-7000	170242	2024/01/10	2025/01/09
	Filter	MICRO TRONICS	BRM50702	G269	2024/01/05	2025/01/04
V	Filter	MICRO TRONICS	BRM50716	G196	2024/01/05	2025/01/04
V	EMI Test Receiver	R&S	ESR3	102793	2023/12/11	2024/12/10
V	Spectrum Analyzer	R&S	FSV3044	101114	2024/02/21	2025/02/20
V	Coaxial Cable	SGH	SGH18	2021005-1	2024/01/10	2025/01/09
V	Coaxial Cable	SGH	SGH18	202108-4	2024/01/10	2025/01/09
V	Coaxial Cable	SGH	HA800	GD20110223-1	2024/01/10	2025/01/09
V	Coaxial Cable	SGH	HA800	GD20110222-3	2024/01/10	2025/01/09

Note:

1. Bi-Log Antenna and Horn Antenna (AH-840) is calibrated every two years, the other equipments are calibrated every one year.
2. The test instruments marked with "V" are used to measure the final test results.
3. Test Software Version: e3 230303 dekra V9.

2. Test Configuration of EUT

2.1. Test Condition

EUT Operational Condition	
Testing Voltage	DC 5V (Power by USB)

2.2. Test Frequency Mode

Test Software Version	UVC Tool / Version 0.1.14.202440326
-----------------------	-------------------------------------

Modulation	Frequency (MHz)	Power Setting
802.11a	5180	default
	5220	default
	5240	default
	5745	default
	5785	default
	5825	default
802.11n (20 MHz)	5180	default
	5220	default
	5240	default
	5745	default
	5785	default
	5825	default
802.11n (40 MHz)	5190	default
	5230	default
	5755	default
	5795	default
802.11ac (20 MHz)	5180	default
	5220	default
	5240	default
	5745	default
	5785	default
	5825	default
802.11ac (40 MHz)	5190	default
	5230	default
	5755	default
	5795	default
802.11ac (80 MHz)	5210	default
	5775	default
802.11ax (20 MHz)	5180	default
	5220	default
	5240	default
	5745	default
	5785	default
	5825	default
802.11ax (40 MHz)	5190	default
	5230	default
	5755	default
	5795	default
802.11ax (80 MHz)	5210	default
	5775	default

2.3. Duty Cycle

Modulation	On Time (ms)	On+Off Time (ms)	Duty Cycle (%)	Duty Factor (dB)	VBW (Hz)
802.11 a	--	--	100.00	0.00	10
802.11 n20	--	--	100.00	0.00	10
802.11 n40	1.5389	1.5598	98.66	0.06	10
802.11 ac20	--	--	100.00	0.00	10
802.11 ac40	1.5439	1.5648	98.66	0.06	10
802.11 ac80	2.2389	2.2548	99.29	0.03	10
802.11 ax20	--	--	100.00	0.00	10
802.11 ax40	1.2389	1.2598	98.34	0.07	10
802.11 ax80	0.3989	0.4288	93.03	0.31	3000

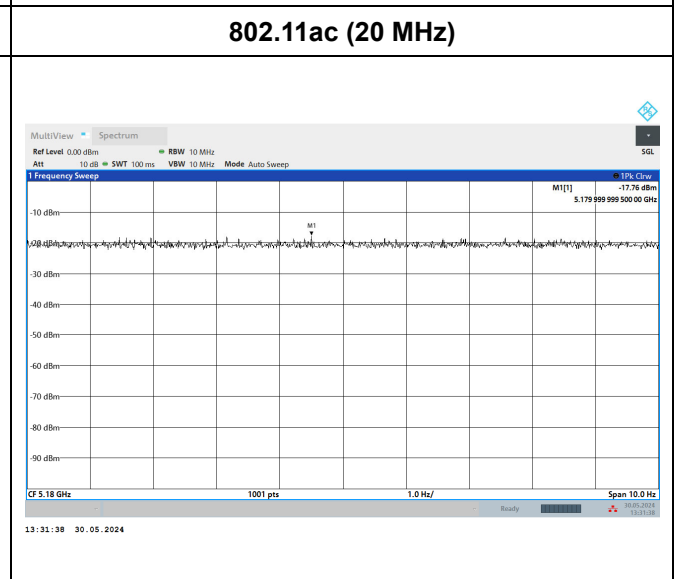
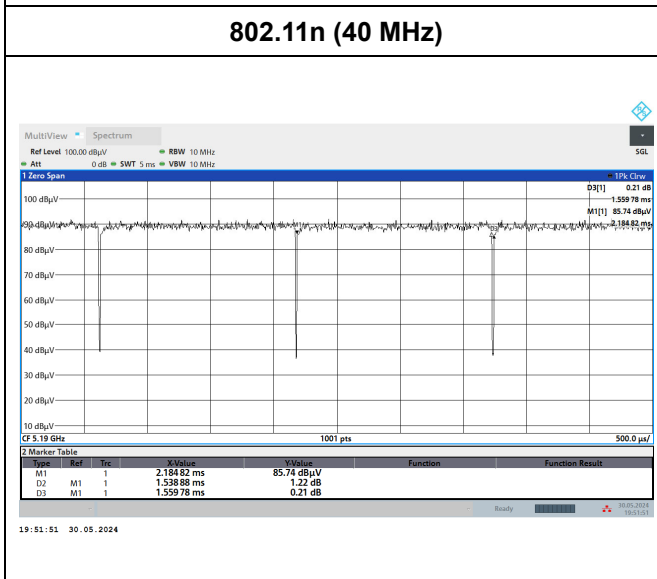
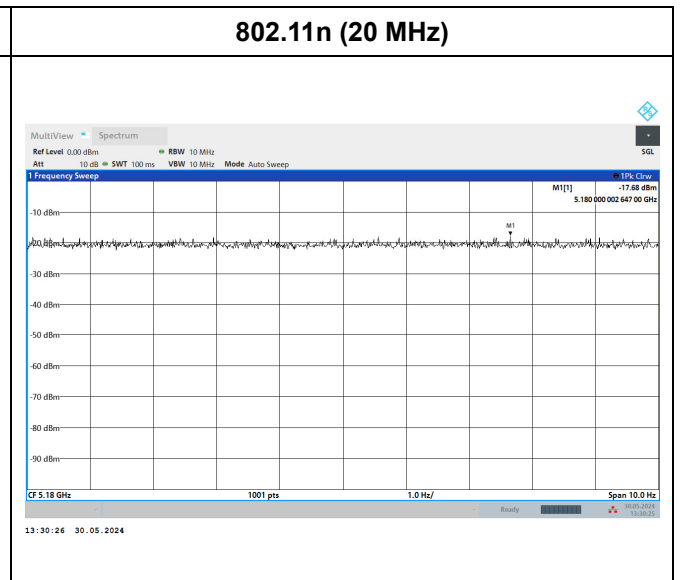
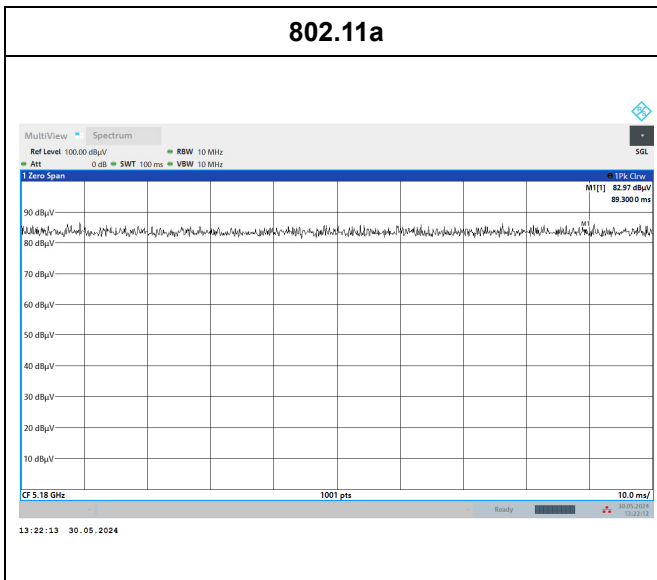

802.11ac (40 MHz)

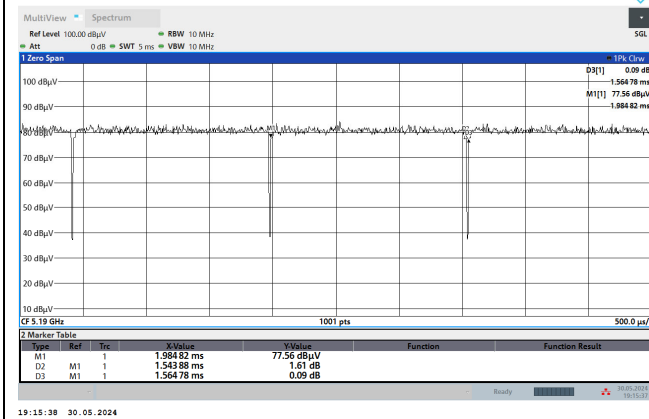

802.11ac (80 MHz)

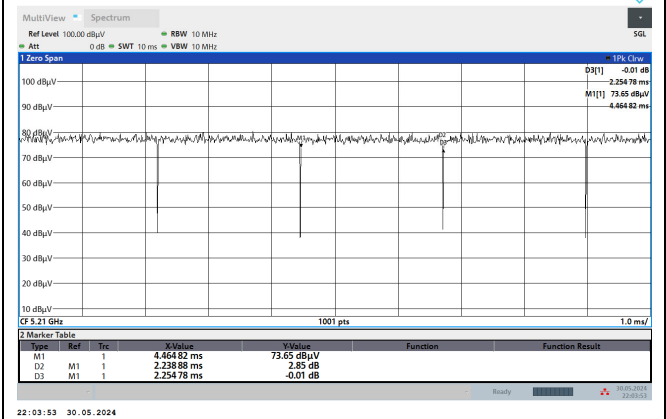

802.11ax (20 MHz)

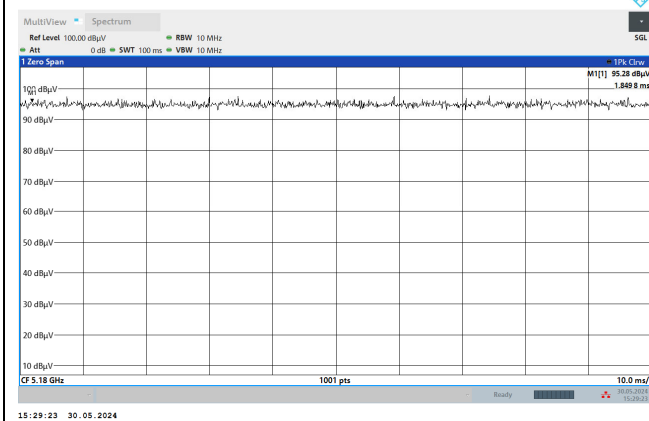

802.11ax (40 MHz)

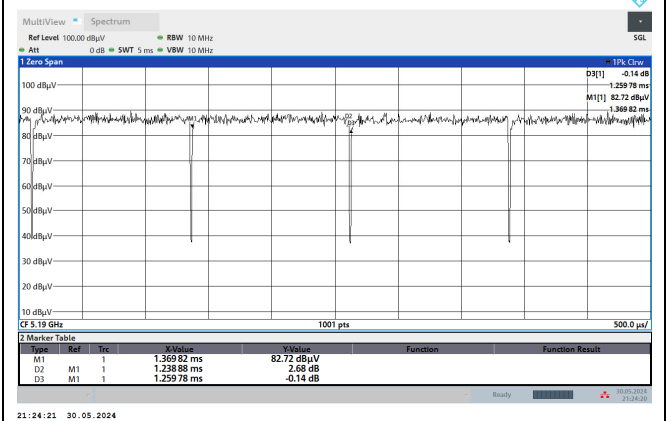

802.11ac (80 MHz)

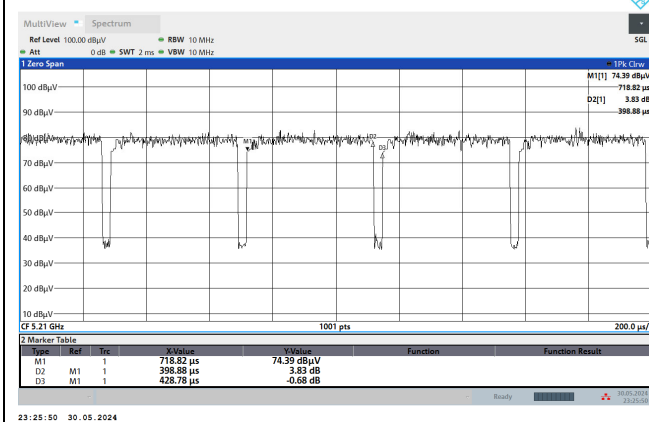

--

--

2.4. Measurement Configuration

Test Mode	Mode 1	Transmit-802.11a
		Transmit-802.11n-20 MHz
		Transmit-802.11n-40 MHz
		Transmit-802.11ac-20 MHz
		Transmit-802.11ac-40 MHz
		Transmit-802.11ac-80 MHz
		Transmit-802.11ax-20 MHz
		Transmit-802.11ax-40 MHz
		Transmit-802.11ax-80 MHz

Note:

1. Determining compliance shall be based on the results of the compliance measurement, not taking into account measurement instrumentation uncertainty.
2. For radiated emission below 1 GHz and AC power line conducted emission have performed all modes of operation were investigated and the worst-case emissions are reported.
3. The radiation measurements are performed in X, Y, Z axis positioning. Only the worst case is shown in the report.
4. The spectrum plot against conducted item only shows the worst case.
5. Lowest data rates are tested in each mode. Only worst case is shown in the report.
(802.11a is 6Mbps, 802.11n 20/40MHz is HT8, 802.11ac/ax 20/40/80MHz is MCS0)

2.5. Tested System Details

No.	Equipment	Brand Name	Model No.	Serial No.	Power Cord
1	Notebook PC	DELL	Latitude 5501	4H94P13	N/A

2.6. Configuration of tested System

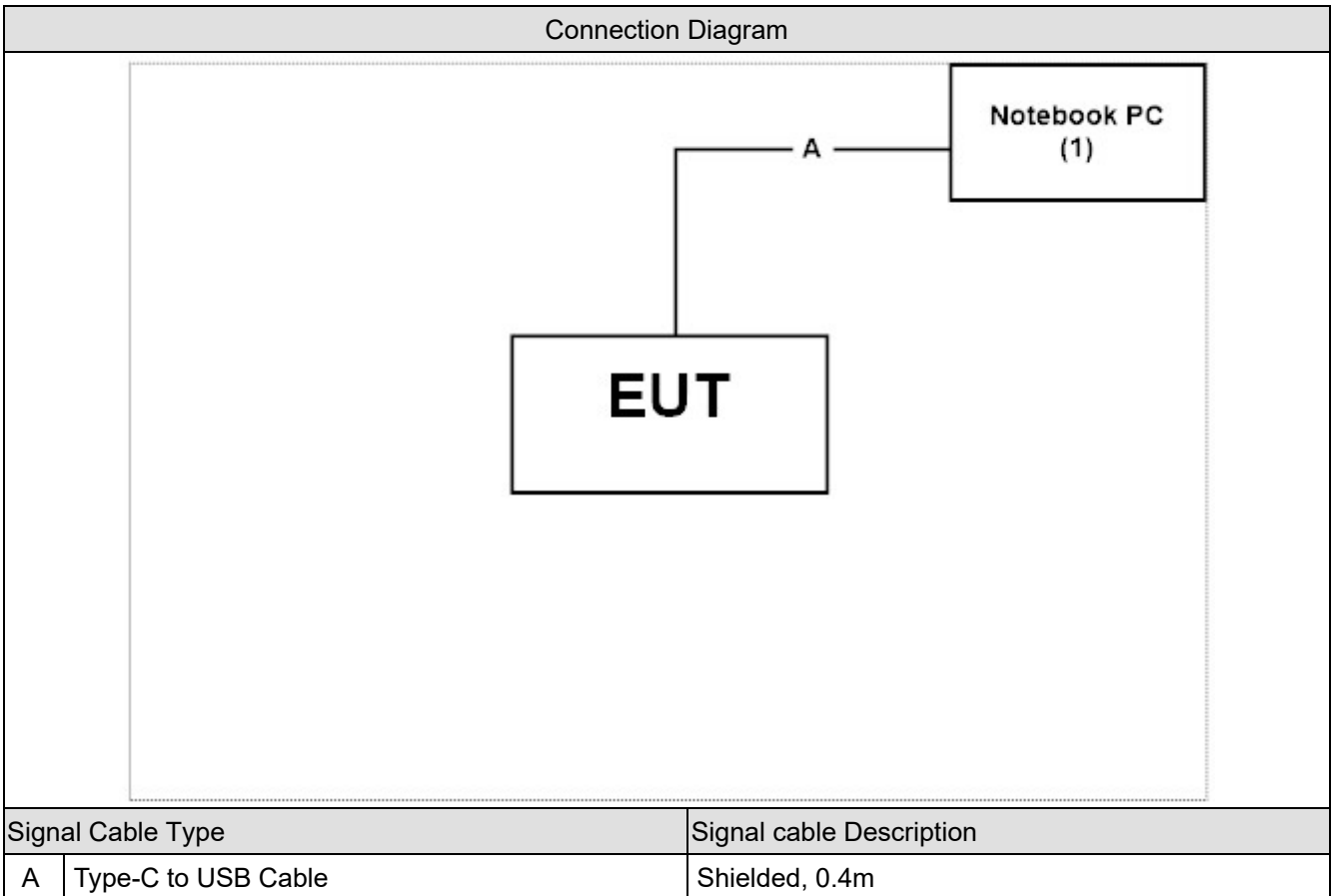

2.7. EUT Operating Procedures

1	Setup the EUT as shown in Section 2.6.
2	Execute software “UVC Tool / Version 0.1.14.202440326” on the Notebook PC.
3	Configure the test mode, the test channel, and the data rate.
4	Verify that the EUT works properly.

3. AC Power Line Conducted Emission

3.1. Test Setup

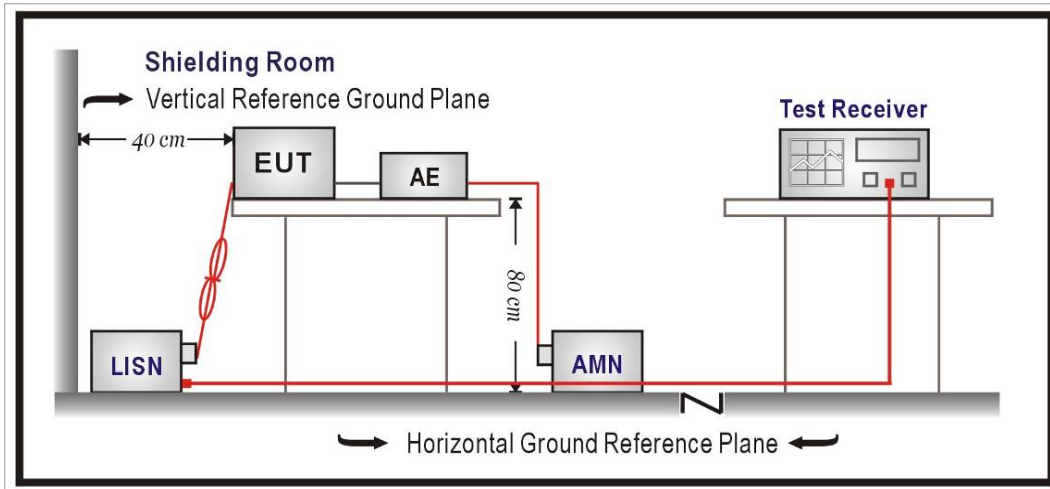

3.2. Test Limit

Frequency (MHz)	QP (dB μ V)	AV (dB μ V)
0.15 - 0.50	66 - 56	56 - 46
0.50 - 5.0	56	46
5.0 - 30	60	50

Remark: In the above table, the tighter limit applies at the band edges.

3.3. Test Procedure

The EUT was setup according to ANSI C63.10: 2013. The EUT was placed on a platform of nominal size, 1 m by 1.5 m, raised 80 cm above the conducting ground plane. The vertical conducting plane was located 40 cm to the rear of the EUT. All other surfaces of EUT were at least 80 cm from any other grounded conducting surface. The EUT and simulators are connected to the main power through a line impedance stabilization network (LISN). The LISN provides a 50 ohm /50uH coupling impedance for the measuring equipment. The peripheral devices are also connected to the main power through a LISN. (Please refer to the block diagram of the test setup and photographs.)

Each current-carrying conductor of the EUT power cord, except the ground (safety) conductor, was individually connected through a LISN to the input power source.

The excess length of the power cord between the EUT and the LISN receptacle were folded back and forth at the center of the lead to form a bundle not exceeding 40 cm in length.

Conducted emissions were investigated over the frequency range from 0.15 MHz to 30 MHz using a receiver bandwidth of 9 kHz.

3.4. Test Result of AC Power Line Conducted Emission

Refer as Appendix A

4. Emission Bandwidth

4.1. Test Setup

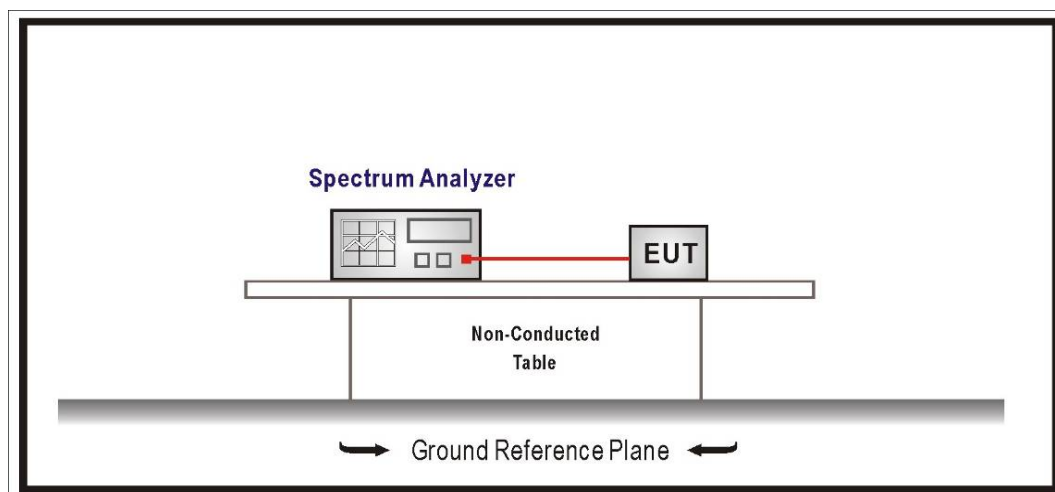

4.2. Test Limit

26 dB Bandwidth : No Required

6 dB Bandwidth \geq 500kHz

4.3. Test Procedure

26 dB Bandwidth :

The EUT was tested according to U-NII test procedure of KDB 789033.

Set RBW 1% of the emission bandwidth, VBW equal to 3 times the RBW.

6 dB Bandwidth :

Set RBW = 100kHz, VBW \geq 3xRBW, Sweep time=Auto, Set Peak detector.

4.4. Test Result of Emission Bandwidth

Refer as Appendix B

5. Maximum Conducted Output Power

5.1. Test Setup

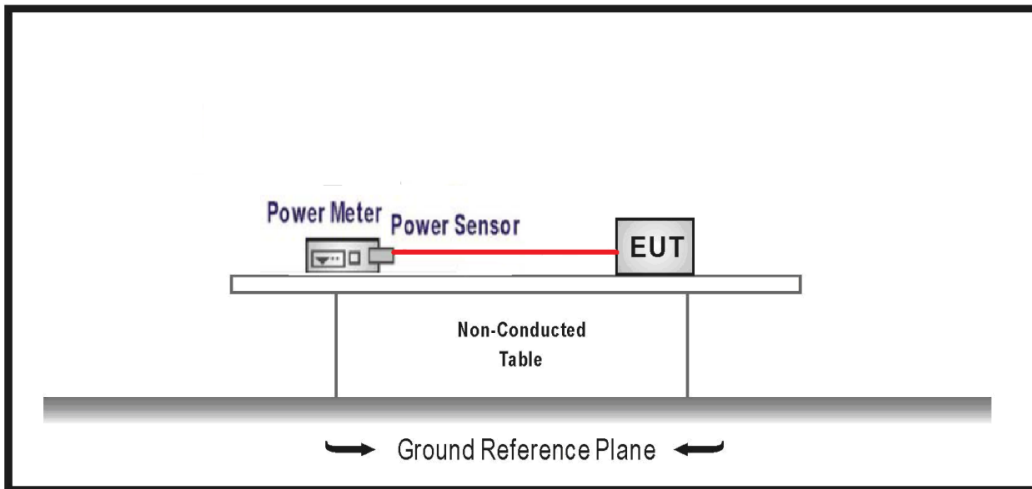

5.2. Test Limit

1. For an outdoor access point and an indoor access point operating in the band 5.15-5.25 GHz, the maximum conducted output power over the frequency band of operation shall not exceed 1 W provided the maximum antenna gain does not exceed 6 dBi. If transmitting antennas of directional gain greater than 6 dBi are used, both the maximum conducted output power and the maximum power spectral density shall be reduced by the amount in dB that the directional gain of the antenna exceeds 6 dBi. For client devices in the 5.15-5.25 GHz band, the maximum conducted output power over the frequency band of operation shall not exceed 250 mW provided the maximum antenna gain does not exceed 6 dBi. If transmitting antennas of directional gain greater than 6 dBi are used, both the maximum conducted output power and the maximum power spectral density shall be reduced by the amount in dB that the directional gain of the antenna exceeds 6 dBi.
2. For the 5.25-5.35 GHz and 5.47-5.725 GHz bands, the maximum conducted output power over the frequency bands of operation shall not exceed the lesser of 250 mW or $11 \text{ dBm} + 10 \log B$, where B is the 26 dB emission bandwidth in megahertz. If transmitting antennas of directional gain greater than 6 dBi are used, both the maximum conducted output power and the maximum power spectral density shall be reduced by the amount in dB that the directional gain of the antenna exceeds 6 dBi.
3. For the band 5.725-5.850 GHz, the maximum conducted output power over the frequency band of operation shall not exceed 1 W. If transmitting antennas of directional gain greater than 6 dBi are used, both the maximum conducted output power and the maximum power spectral density shall be reduced by the amount in dB that the directional gain of the antenna exceeds 6 dBi.

5.3. Test Procedure

The EUT was setup to ANSI C63.10: 2013; tested to U-NII test procedure of 789033.

5.4. Test Result of Maximum Conducted Output Power

Refer as Appendix C

6. Maximum Power Spectral Density

6.1. Test Setup

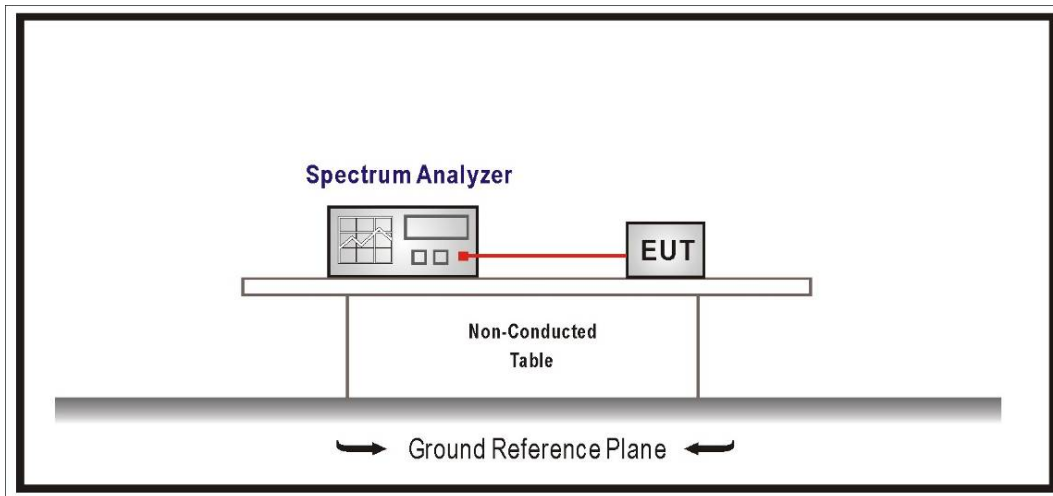

6.2. Test Limit

1. For the band 5.15 ~ 5.25 GHz, the peak power spectral density shall not exceed 17 dBm in any 1 MHz band. If transmitting antenna of directional gain greater than 6 dBi are used, the peak power spectral density shall be reduced by the amount in dB that directional gain of the antenna exceeds 6 dBi.
2. For client devices in the 5.15 ~ 5.25 GHz band, the maximum power spectral density shall not exceed 11 dBm in any 1 megahertz band. If transmitting antennas of directional gain greater than 6 dBi are used, both the maximum conducted output power and the maximum power spectral density shall be reduced by the amount in dB that the directional gain of the antenna exceeds 6 dBi
3. For the 5.25 ~ 5.35 GHz ,5470 ~ 5600 MHz and 5650 ~ 5725 MHz, the peak power spectral density shall not exceed 11 dBm in any 1-MHz band. If transmitting antenna of directional gain greater than 6 dBi are used, the peak power spectral density shall be reduced by the amount in dB that directional gain of the antenna exceeds 6 dBi.
4. For the band 5.725 ~ 5.850 GHz, the peak power spectral density shall not exceed 30 dBm in any 500 kHz band. If transmitting antenna of directional gain greater than 6 dBi are used, the peak power spectral density shall be reduced by the amount in dB that directional gain of the antenna exceeds 6 dBi.

6.3. Test Procedure

The EUT was setup to ANSI C63.10: 2013; tested to U-NII test procedure of 789033.

6.4. Test Result of Maximum Power Spectral Density

Refer as Appendix D

7. Transmitter Radiated Spurious Emission

7.1. Test Setup

9 kHz ~ 30 MHz

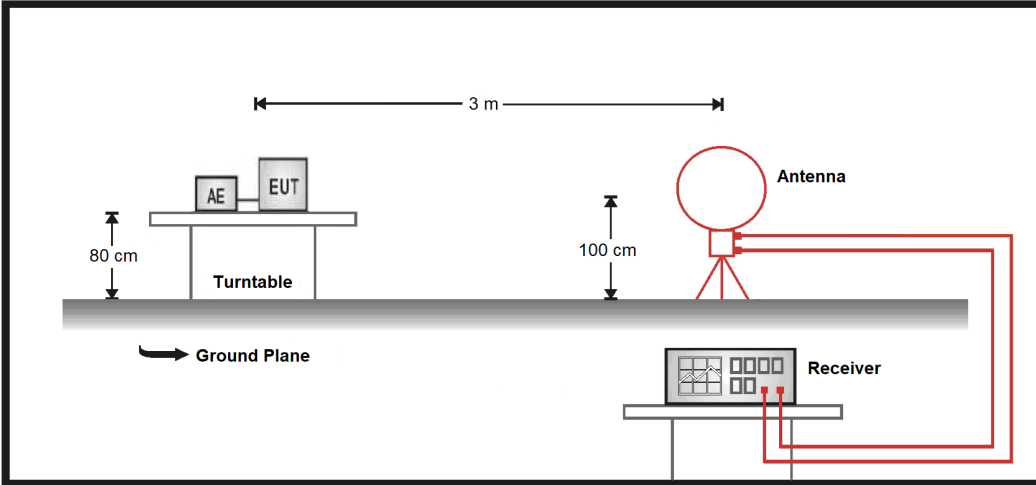

30 MHz ~ 1 GHz

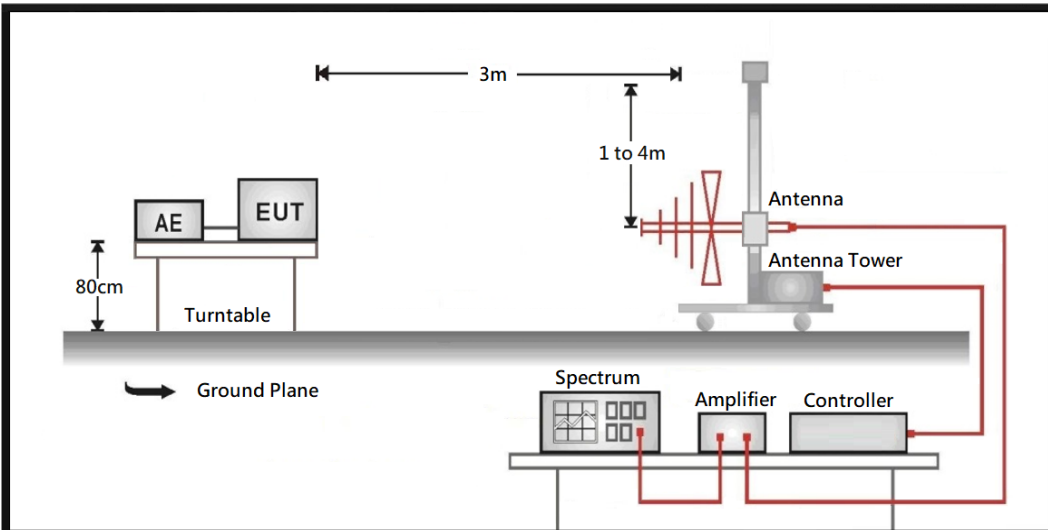

Above 1 GHz

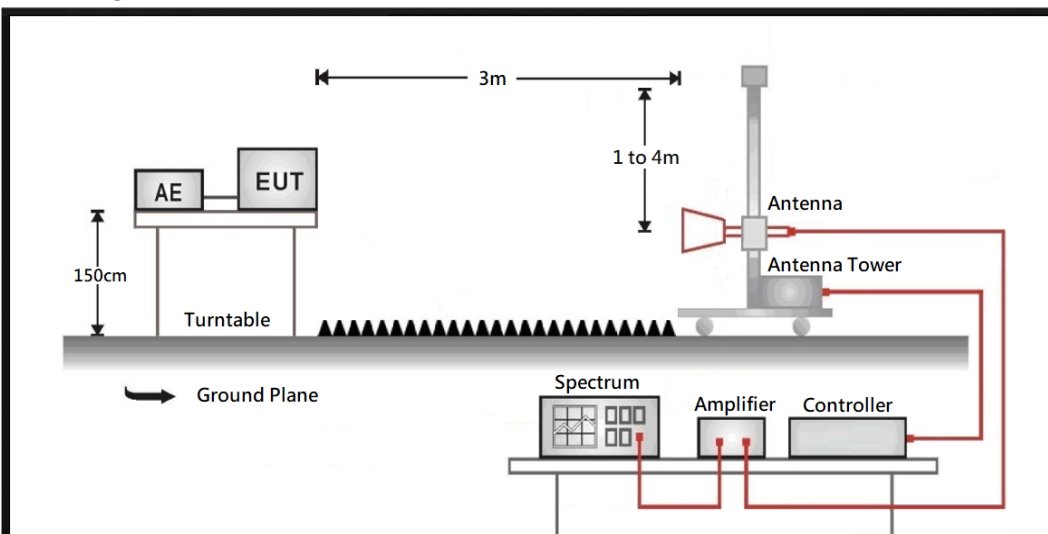

7.2. Test Limit

Frequency (MHz)	Field strength ($\mu\text{V/m}$)	Field strength ($\text{dB}\mu\text{V/m}$)	Measurement distance (m)
0.009 – 0.490	2400/F(kHz)	20 log (2400/F(kHz))	300
0.490 – 1.705	24000/F(kHz)	20 log (24000/F(kHz))	30
1.705 - 30	30	29.5	30
30 - 88	100	40	3
88 - 216	150	43.5	3
216 - 960	200	46	3
Above 960	500	54	3

Remarks:

- Field strength ($\text{dB}\mu\text{V/m}$) = 20 log Field strength ($\mu\text{V/m}$)
- In the Above Table, the tighter limit applies at the band edges.
- Distance refers to the distance in meters between the measuring instrument antenna and the closed point of any part of the device or system

Unwanted Emission out of the restricted bands Test Limit

Frequency (MHz)	EIRP Limit (dBm/MHz)	Equivalent Field Strength ($\text{dB}\mu\text{V/m@3m}$)
5150 – 5250	-27	68.2
5250 – 5350	-27	68.2
5470 – 5725	-27	68.2
5725 – 5850	-27 ^{*1}	68.2 ^{*1}
	10 ^{*2}	105.2 ^{*2}
	15.6 ^{*3}	110.8 ^{*3}
	27 ^{*4}	122.2 ^{*4}

^{*1} beyond 75 MHz or more above of the band edge.

^{*2} below the band edge increasing linearly to 10 dBm/MHz at 25 MHz above.

^{*3} below the band edge increasing linearly to a level of 15.6 dBm/MHz at 5 MHz above.

^{*4} from 5 MHz above or below the band edge increasing linearly to a level of 27 dBm/MHz at the band edge.

Remark:

The following formula is used to convert the equipment isotropic radiated power (eirp) to field strength:

$$E = \frac{1000000\sqrt{30P}}{3} \text{ uV/m, where P is the eirp (Watts).}$$

7.3. Test Procedure

The EUT and its simulators are placed on a turn table which is 0.8 or 1.5 meter above ground. The turn table can rotate 360 degrees to determine the position of the maximum emission level. The EUT was positioned such that the distance from antenna to the EUT was 3 meters.

The antenna can move up and down between 1 meter and 4 meters to find out the maximum emission level. Both horizontal and vertical polarization of the antenna are set on measurement. In order to find the maximum emission, all of the interface cables must be manipulated according to ANSI C63.10: 2013 on radiated measurement.

The additional latch filter below 1 GHz was used to measure the level of harmonics radiated emission during field strength of harmonics measurement.

The bandwidth below 1 GHz setting on the field strength meter is 120 kHz, above 1 GHz are 1 MHz.

The frequency range from 9 kHz to 10th harmonics and included The frequency range from the lowest oscillator frequency generated within the device up to the 10th harmonic was checked is checked.

7.4. Test Result of Transmitter Radiated Spurious Emission

Refer as Appendix E