

RICOH

G900
G900SE
Operating Manual

The serial number is located inside the battery/card cover.

Chapter 1: Introduction

Read this chapter before use.

This chapter gives you an overview of the RICOH G900 and RICOH G900SE.

Chapter 2: Getting Started

Read this chapter before using the RICOH G900 and RICOH G900SE for the first time.

This chapter explains about basic operations such as turning the camera on, performing shooting, and playing back images.

Chapter 3 and later

Read these chapters when you want to learn more about the different camera functions.

These chapters explain about shooting and playback functions, as well as how to customize the camera settings and use it with a computer.

Model: R02060
R02070

Regarding User Registration

Thank you for purchasing a RICOH product.

In order to provide you with the best customer support and service experience for the product you have purchased, we ask you to complete the user registration.

Visit the following website to complete the user registration.

<http://www.ricoh-imaging.com/registration/>

Registered users will be notified by e-mail about important customer support information, such as firmware version updates, etc.

Introduction

This Operating Manual provides information on how to use the shooting and playback functions of this camera and related precautions.

Thoroughly read this Operating Manual to make the best use of the functions available with this camera. Be sure to keep this Operating Manual for future reference.

It is recommended to update the camera firmware to the latest version before using the camera.

For details on the latest firmware version, refer to the following firmware download site.
<http://www.ricoh-imaging.co.jp/english>

RICOH COMPANY, LTD.

Safety precautions	Read all safety precautions thoroughly to ensure safe use.
Test shots	Take test shots to ensure that the camera is working properly before taking pictures on important occasions.
Copyright	Reproduction or alteration of copyrighted documents, magazines, and other materials, other than for personal, home, or other similarly limited purposes, without the consent of the copyright holder, is prohibited.
Exemption from liability	RICOH COMPANY assumes no liability for failure to record or display images as a result of product malfunction.
Notes on radio waves	<ul style="list-style-type: none">• As this camera is certified as compliant with the technical standards, disassembly or modification of the camera is punishable by law.• In the frequency band used by the camera, along with industrial, scientific, and medical devices such as microwave ovens, premises radio stations (radio stations requiring a license) and specified low power radio stations (radio stations requiring no license) for mobile object identification used in factory production lines, etc., and amateur radio stations (radio stations requiring license) are operated.<ol style="list-style-type: none">1. Before using the camera, confirm that premises radio stations and specified low power radio stations for mobile object identification and amateur radio stations are not operated in the vicinity.2. In the event that the camera causes harmful radio wave interference to premises radio stations for mobile object identification, immediately change the frequency being used or immediately stop the emission of radio waves and consult your service center about measures against the interference such as installing partitions.3. If you have other troubles such that the camera causes harmful radio wave interference to specified low power radio stations for mobile object identification or to amateur radio stations, contact your service center.

Radio interference	<p>Operating this camera in the vicinity of other electronic equipment may adversely affect both the camera and the other device. Interference is particularly likely if the camera is used in close proximity to a radio/TV receiver. In such case, take the following measures.</p> <ul style="list-style-type: none">• Keep the camera as far away as possible from the radio/TV receiver.• Reorient the antenna of the radio/TV receiver.• Use a different wall outlet.
--------------------	---

This publication may not be reproduced in whole or in part without RICOH COMPANY's express written permission.
© RICOH COMPANY, LTD. 2019
RICOH COMPANY reserves the right to change the contents of this manual at any time without prior notice.
Every effort has been made to ensure the accuracy of the information in this manual. Should you nevertheless notice any errors or omissions, we would be grateful if you would notify us at the address listed on the back cover of this manual.

About Wireless LAN and Bluetooth® Functions (G900SE Only)

- Available frequency bands vary depending on the country. Use the wireless LAN function of this product only in the country of purchase.
- The use of the 5 GHz band is prohibited in some countries. When using the 5 GHz band, observe local laws and regulations.
- This product uses only W52 channels (36ch to 48ch) in the 5 GHz band of wireless LAN. (Indoor use only)
- In Japan, indoor use only, except connecting to 5.2 GHz high power base station.
- Do not use the camera in a place where electrical products, AV/OA devices, and so on generate magnetic fields and electromagnetic waves.
- If the camera is affected by magnetic fields and electromagnetic waves, it may not be able to communicate.
- If the camera is used near a TV or a radio, poor reception or TV screen glitch may occur.
- If there are multiple wireless LAN access points or Bluetooth® devices near the camera and the same channel is used, search operation may not be executed correctly.
- The security of your data stored, sent or received is your own responsibility.

In the frequency band used by the camera, along with industrial, scientific, and medical devices such as microwave ovens, premises radio stations (radio stations requiring a license) and specified low power radio stations (radio stations requiring no license) for mobile object identification used in factory production lines, etc., and amateur radio stations (radio stations requiring a license) are operated.

1. Before using the camera, confirm that premises radio stations and specified low power radio stations for mobile object identification and amateur radio stations are not operated in the vicinity.
2. In the event that the camera causes harmful radio wave interference to premises radio stations for mobile object identification, immediately change the frequency being used to avoid interference.
3. If you have other troubles such that the camera causes harmful radio wave interference to specified low power radio stations for mobile object identification or to amateur radio stations, contact your nearest service center.

This camera conforms to the technical standards under the Radio Law and Telecommunications Business Law and the certification of conformance to technical standards can be displayed on the monitor.



Displaying the Certification Marks

- 1 Display the menu.
- 2 Select [Certifications] in the  menu.

Trademarks

- Microsoft, Windows, and Windows Server are registered trademarks of Microsoft Corporation in the United States of America and other countries.
 - Mac, macOS, OS X, and App Store are trademarks of Apple Inc., registered in the U.S. and other countries.
 - SDXC Logo is a trademark of SD-3C, LLC.
 - FlashAir is a trademark of Toshiba Memory Corporation.
 - Google, Google Play, and Android are trademarks or registered trademarks of Google Inc.
 - The Bluetooth word mark and logos are registered trademarks owned by Bluetooth SIG, Inc., and any use of such marks by Ricoh Company, Ltd. is under license.
 - USB Type-C is a trademark of USB Implementers Forum.
 - HDMI, the HDMI logo, and High-Definition Multimedia Interface are trademarks or registered trademarks of HDMI Licensing, LLC in the United States and/or other countries.
 - FeliCa is a registered trademark of Sony Corporation. FeliCa is the contactless IC card technology developed by Sony Corporation.
 - MIFARE is a registered trademark of NXP Semiconductors N.V.
 - This product supports the Quasi-Zenith Satellite System "Michibiki".
- All other trademarks are the property of their respective owners.
- This product uses the RICOH RT font designed by RICOH COMPANY, LTD.

AVC Patent Portfolio License

This product is licensed under the AVC Patent Portfolio License for the personal use of a consumer or other uses in which it does not receive remuneration to (i) encode video in compliance with the AVC standard ("AVC video") and/or (ii) decode AVC video that was encoded by a consumer engaged in a personal activity and/or was obtained from a video provider licensed to provide AVC video.

No license is granted or shall be implied for any other use.

Additional information may be obtained from MPEG LA, L.L.C.

See <http://www.mpegla.com>.

Announcement about the Open Source Software

This camera includes the open source software (OSS) licensed under the GNU General Public License (GPL), GNU Lesser General Public License (LGPL), and/or other licenses. The information about licenses of each OSS used in the camera is saved in the camera internal memory as a text file. Connect the camera to a computer after setting [USB Connection] to [CD-ROM] in the  menu of the camera, and then open the text file in the "oss_license" folder to read the license terms.



The source codes of OSS used in the camera are disclosed under the license terms of GPL, LGPL, etc. If you need the source codes, access the following URL.

<http://www.ricoh-imaging.co.jp/english/products/oss/>







Safety Precautions

Warning Symbols

Various symbols are used throughout this Operating Manual and on the product to prevent physical harm to you or other people and damage to property. The symbols and their meanings are explained below.





 Danger	This symbol indicates matters that may lead to imminent risk of death or serious injury if ignored or incorrectly handled.
 Warning	This symbol indicates matters that may lead to death or serious injury if ignored or incorrectly handled.
 Caution	This symbol indicates matters that may lead to injury or property damage if ignored or incorrectly handled.

Meaning of Symbols

	The  symbol alerts you to actions that must be performed.
	The  symbol alerts you to prohibited actions. The  symbol may be combined with other symbols to indicate that a specific action is prohibited. Example:  : Do not touch  : Do not disassemble

Observe the following precautions to ensure safe use of this camera.

Danger

	<ul style="list-style-type: none">Do not attempt to disassemble, repair, or alter the camera yourself. The high-voltage circuitry in the equipment poses significant electrical hazard.
	<ul style="list-style-type: none">Do not attempt to disassemble, alter, or directly solder the battery.
	<ul style="list-style-type: none">Do not put the battery in a fire, attempt to heat it, or use or leave it in a high temperature environment such as next to a fire or inside a car. Do not put it into water or the sea or allow it to get wet.
	<ul style="list-style-type: none">Do not attempt to pierce, hit, compress, drop, or subject the battery to any other severe impact or force.
	<ul style="list-style-type: none">Do not use a battery that is significantly damaged or deformed.

 **Warning**



- Turn off the power immediately in the event of abnormalities such as smoke or unusual odors being emitted. Remove the battery as soon as possible, being careful to avoid electric shocks or burns. If you are drawing power from a household electrical outlet, be sure to unplug the power plug from the outlet. Failure to observe this precaution could result in fire or electric shocks. Contact the nearest service center at your earliest convenience. Stop using the camera immediately if it is malfunctioning.



- Turn off the power immediately if any metallic object, water, liquid, or other foreign object gets into the camera. Remove the battery and memory card as soon as possible, being careful to avoid electric shocks or burns. If you are drawing power from a household electrical outlet, be sure to unplug the power plug from the outlet. Failure to observe this precaution could result in fire or electric shocks. Contact the nearest service center at your earliest convenience. Stop using the camera immediately if it is malfunctioning.



- If the monitor is damaged, avoid any contact with the liquid crystal inside it. Follow the appropriate emergency measures below.
- SKIN: If any of the liquid crystal gets on your skin, wipe it off and rinse the affected area thoroughly with water, then wash well with soap.
- EYES: If it gets in your eyes, wash your eyes with clean water for at least 15 minutes and seek medical advice immediately.
- INGESTION: If any of the liquid crystal is ingested, rinse the mouth out thoroughly with water. Have the person drink a large amount of water and induce vomiting. Seek medical assistance immediately.



- Follow these precautions to prevent the battery from leaking, overheating, igniting, or exploding.
- Do not use a battery other than those specifically recommended for the camera.
- Do not carry or store the battery together with metal objects such as ball-point pens, necklaces, coins, and hairpins.
- Do not put the battery into a microwave or high pressure container.
- If leakage of battery fluid, a strange odor, color change, etc. is noticed during use or during charging, remove the battery from the camera or battery charger immediately and keep it away from fire.



- Observe the following in order to prevent fire, electrical shock, or cracking of the battery while charging.
- Use only the indicated power supply voltage. Also avoid the use of multi-socket adapters and extension cords.
- Do not damage, bundle, or alter the AC plug cord. Also, do not place heavy objects on, stretch, or bend the AC plug cord.
- Do not connect or disconnect the power plug with wet hands. Always grip the plug section when disconnecting a power plug. Do not cover the camera while charging the battery.



- Keep the battery and SD memory card used in the camera out of the reach of children to prevent accidental swallowing. The battery and memory card are harmful if swallowed. Seek medical assistance immediately.



- Keep the camera out of the reach of children. For children, accidents may occur because they cannot understand the contents of "Safety Precautions" and "Precautions for Use".



- Do not touch the internal components of the camera if they become exposed as a result of being dropped or damaged. The high-voltage circuitry in the equipment could lead to electric shocks. Remove the battery as soon as possible, being careful to avoid electric shocks or burns. Take the camera to your nearest dealer or service center if it is damaged.



- When using the camera in wet areas such as a kitchen, be careful not to wet the inside of the camera. Failure to observe this precaution could result in fire or electric shocks.



- Do not use the camera near flammable gases, gasoline, benzene, thinner, or similar substances. Failure to observe this precaution could result in an explosion, fire, or burns.
- Do not use the camera in a location where usage is restricted or prohibited, such as on airplanes. Failure to observe this precaution could result in an accident.



- Wipe off any dust that accumulates on the power plug. Failure to observe this precaution could result in fire.
- When using a household power outlet, always use the dedicated AC adapter. Failure to observe this precaution could result in fire, electric shocks, or product malfunction.



- Do not use the battery charger or AC adapter with commercially available electronic transformers when traveling abroad. Failure to observe this precaution could result in fire, electric shocks, or product malfunction.

 **Caution**



- Contact with fluid leaking from a battery can lead to burns. If part of your body comes in contact with a damaged battery, rinse the area with water immediately. (Do not use soap.)
If a battery starts to leak, remove it immediately from the camera and wipe the battery chamber thoroughly before replacing it with a new battery.



- Plug the power plug securely into the electrical outlets. Failure to observe this precaution could result in fire.



- Do not allow the camera interior to get wet. When operating the camera with wet hands, be careful not to get the camera interior wet. Failure to observe this precaution could result in electric shocks.



- Do not fire the flash at drivers of vehicles, as this may cause the driver to lose control and result in a traffic accident. Failure to observe this precaution could result in a traffic accident.

**Safety Precautions
for Accessories**

When using optional products, carefully read the user's manuals provided with the product before using that product.



Caution

- Only the camera is chemical-resistant. Accessories are not resistant to chemicals.

Contents

Introduction	1
Safety Precautions.....	5
1 Introduction	13
Checking the Contents of the Package	13
Names and Functions of the Working Parts.....	14
Operating Controls	16
Indicators on the Monitor.....	18
Shooting Screen.....	18
Playback Screen	19
Changing the Screen Display	20
How to Change Function Settings	22
Using the Button.....	22
Setting from the Menus.....	24
Menu List	26
📷 Shooting Menu	26
🎬 Movie Menu	27
▶ Playback Menu	28
⚙️ Customize Menu.....	29
🔧 Setup Menu.....	30
📄 Expanded Settings Menu.....	31
🌐 Network Menu (G900SE Only).....	32
2 Getting Started	34
Setting the Battery and a Memory Card	34
Inserting the Battery and a Memory Card.....	34
Charging the Battery	37
Initial Settings	39
Turning the Camera On.....	39
Setting the Language and the Date and Time.....	40
Formatting a Memory Card.....	40
Basic Shooting Operation.....	42
Shooting in the Auto Mode	42
Viewing the Captured Images.....	43
3 Taking Pictures	44
Taking Still Images	44
Setting the Capture Mode.....	44
Using Exposure Compensation	46
Recording Movies	47
Playing Back Movies	48

Setting the Focus Mode	49
Focusing Manually (Manual Focus)	51
Setting the Exposure	52
Selecting a Metering Method	52
Setting the ISO Sensitivity	53
Using the Flash	54
Setting the White Balance	56
Setting the White Balance Manually	57
Setting the Drive Mode	58
Shooting Using the Self-timer	58
Shooting Continuously	59
Shooting Using the Remote Control Unit	60
Shooting with Varied Exposure Values	61
Configuring the Capture Settings	62
Image Capture Settings	62
Movie Capture Settings	62
Setting the Image Finishing Tone and Correction	63
Setting the Image Atmosphere (Image Tone)	63
Setting the Sharpness, Saturation, Tone, and Contrast	64
Imprinting the Date on Still Images	64
Capturing Images with Clearer Details	64
Correcting a Range of Tones (D-Range Setting)	65
Reducing Blurring of Images	65
Correcting a Rectangular Subject (Skew Correction)	66
Detecting Edited Images	67
Adding Information to Captured Images	68
Using the Camera Memo	68
Capturing Images at the Same Angle (Watermark Options)	73
Attaching an Auxiliary Image (Image Clip)	75
Compositing Images during Shooting	77
4 Playback Functions	79
Changing the Playback Method	79
Displaying Multiple Images	79
Playing Back Images Continuously (Slideshow)	80
Displaying Rotated Images	81
Connecting the Camera to an AV Device	82
Organizing Files	83
Deleting Files	83
Copying Images	84
Protecting Images from Deletion	85

Editing and Processing Images	86
Changing the Image Size.....	86
Processing Images with Filters.....	88
Editing Movies	89
Correcting Red Eyes in Images	91
5 Using Communications and Network	92
Using a Computer	92
Setting the Connection Mode	92
Copying Images to a Computer	93
Using the Provided Software.....	94
Operating the Camera with a Computer (G900SE Only).....	95
Using the Network (G900SE Only).....	96
Selecting the Communication Method.....	96
Operating the Camera with a Communication Device.....	97
Setting the Wireless LAN Connection	98
Setting the Bluetooth® Connection	100
Transmitting Files.....	101
Using the Support Functions	103
Setting the Camera Operations When Using a Dedicated Server.....	103
6 Changing the Settings	105
Saving Frequently Used Settings.....	105
Using the Mode Dial	105
Exporting the Settings to a File	106
Customizing the Button Functions	107
Registering Functions to the ADJ. Button.....	107
Registering Functions to the Fn Button.....	108
Display and Sound Settings.....	109
Setting the Start-up Screen	109
Setting the Information Displayed when the Camera Is Turned On/Off	109
Setting the Live View Display	109
Setting the Brightness of the Monitor	110
Setting the Lamp	110
Setting the Sound Volume	110
Power Saving Settings	111
Automatically Turning the Power Off	111
Dimming the Display.....	111
Setting the GPS	113
Displaying the GPS Information.....	114
Automatically Adjusting the Date and Time Settings	115
Recording the Camera Route.....	115
Setting the Direction Information	117
Imprinting the GPS Information.....	117

File Management Settings	118
Specifying the Folder/File Settings	118
Setting the Copyright Information.....	122
Saving the Local Date and Time of the Specified City.....	124
Camera Memo Settings	125
Setting the Camera Memo Mode	125
Using a Barcode.....	126
Using an IC Card (G900SE Only).....	128
Security Settings.....	129
Setting a Password on the Camera	129
Setting a Password on the Memory Card.....	131
Setting the Password Validity Period.....	132

7 Appendix 133

Attaching Optional Accessories	133
Wide Conversion Lens.....	133
AC Adapter	134
Troubleshooting	135
Power Supply	135
Shooting	136
Playback/Deletion	137
Others	139
Error Messages.....	140
Main Specifications.....	141
Camera	141
USB Power Adapter AC-U1/AC-U2.....	145
Rechargeable Battery DB-110	145
Battery Charger BJ-11	145
Image Storage Capacity.....	146
Operating Environment	147
Using the Camera Abroad	148
Precautions for Use	149
Camera Care and Storage.....	153
Warranty Policy.....	155
Regulatory Compliance Statements.....	156
Index.....	163

Checking the Contents of the Package

Before using your digital camera, confirm that the package contains the items listed below.



RICOH G900
RICOH G900SE

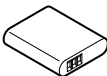

Rechargeable battery (DB-110)

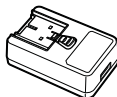

USB power adapter (AC-U1 or AC-U2)*



Power plug

* Differs depending on the region.

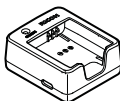

Battery charger (BJ-11)



Macro stand (O-MS3)

- **USB cable (I-USB173)**
- **Neck strap (O-ST174)**
- **Operating Manual (this manual)**
- **Regarding Waterproof Design**



Macro Stand

- The macro stand is used to keep a distance of 1 cm between the lens and the subject. Attach the macro stand to the camera by screwing it into the lens. You can use it in capture modes such as the digital microscope mode. (p.44)
- When the macro stand is attached to the camera, it may be difficult to focus on the subject depending on the type of subject.



Software Operating Manual

- The "Operating Manual (for Software)" explaining how to use the provided software is included in the internal memory of the camera. (p.94)

Names and Functions of the Working Parts

1

Introduction

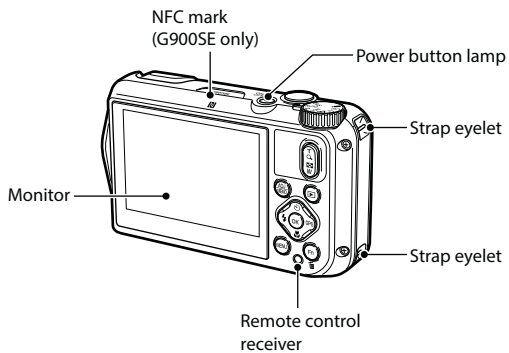
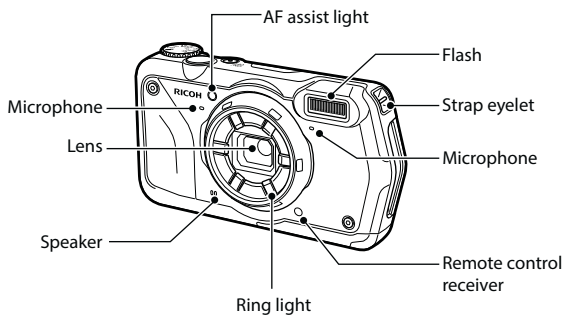

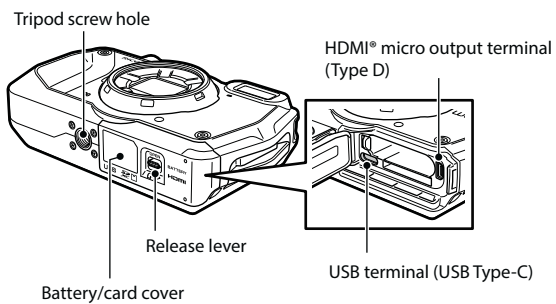

Operating Controls

This section explains about operating controls.
The icons in parentheses are used in the descriptions of this manual.

1 Introduction

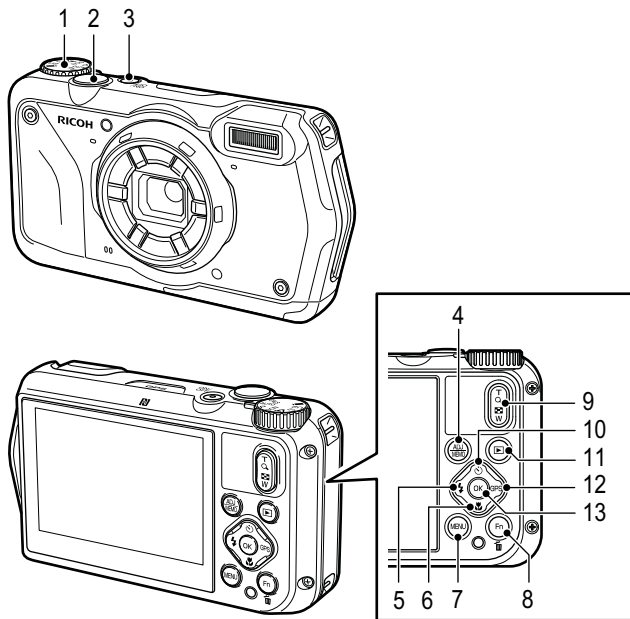

- 1 Mode dial**
Changes the capture mode. (p.44)
- 2 Shutter release button (SHUTTER)**
Press to capture images.
Press halfway to activate autofocus. (p.42)
- 3 Power button**
Turns the power on or off. (p.39)
- 4 ADJ./MEMO button (ADJ./MEMO)**
Calls ADJ. mode functions and sets the camera memo. (p.23, p.69)
- 5 Flash/Left button (FLASH/LEFT)**
Changes the flash mode. (p.54)
Moves the cursor to the left when an item is selected.

- 6 Focus/Down button (F4/▼)**
Changes the focus mode. (p.49)
Moves the cursor down when an item is selected.
- 7 MENU button (MENU)**
Displays a menu. Press this button while the menu is displayed to return to the previous screen. (p.24)
- 8 Fn//Delete button (Fn / F5)**
Calls the assigned function. (p.23)
In the playback mode, press to delete images. (p.43)
- 9 Zoom button (Q (T), W)**
Changes the zoom magnification. (p.42)
- 10 Drive/Up button (S / ▲)**
Changes the drive mode. (p.58)
Moves the cursor up when an item is selected.
- 11 Playback button (L2)**
Switches between the shooting mode and the playback mode. (p.43)
- 12 GPS/Right button (GPS / ►)**
Press and hold to turn the GPS function on or off. (p.114)
Moves the cursor to the right when an item is selected.
- 13 OK button (OK)**
Switches the information displayed on the shooting screen and playback screen. (p.20)
Confirms the selected items when setting a function.

Indicators on the Monitor

Shooting Screen

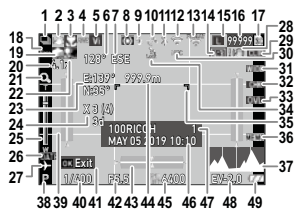

Still image mode

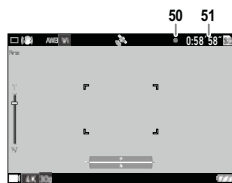

Movie mode

- | | | | |
|----|--|----|---|
| 1 | Drive mode (p.58) | 25 | Zoom bar/Focus bar (p.42, p.51) |
| 2 | Motion blur reduction/Movie SR (p.65) | 26 | Date imprint (p.64) |
| 3 | Focus mode (p.49) | 27 | World time (p.124) |
| 4 | White balance (p.56) | 28 | Camera shake warning |
| 5 | Image tone (p.63) | 29 | Image clip (p.77) |
| 6 | Electronic compass information (azimuth) (p.117) | 30 | NFC (p.128) *1 |
| 7 | Electronic compass direction | 31 | Conversion lens (p.133) |
| 8 | AE metering (p.52) | 32 | Edit detection (p.67) |
| 9 | Flash mode (p.54) | 33 | Image composition (p.77) |
| 10 | GPS positioning status (p.114) | 34 | GPS lock (p.115) |
| 11 | Bluetooth® communication (p.96) *1 | 35 | Focus frame |
| 12 | Wireless LAN communication (p.96) *1 | 36 | Camera memo (p.69) |
| 13 | FlashAir communication status (p.35) | 37 | Histogram |
| 14 | Aspect ratio (p.62) | 38 | Capture mode (p.44) |
| 15 | Recorded pixels (p.62) | 39 | Grid guide (p.109) |
| 16 | Number of storable images | 40 | Shutter speed |
| 17 | Storage location (p.35) | 41 | Operation guide |
| 18 | Face detection (p.50) | 42 | Aperture value |
| 19 | Highlight correction (p.65) | 43 | Electronic level (p.109) |
| 20 | Zoom magnification (p.42) | 44 | External range finder information (p.100) *1 |
| 21 | Digital zoom (p.43) | 45 | ISO setting (p.53) |
| 22 | Shadow correction (p.65) | 46 | Date and time (p.40) |
| 23 | GPS information (p.114) | 47 | Save destination folder (p.118)/
Number of files |
| 24 | GPS positioning quality | 48 | Exposure compensation (p.46) |

49 Battery level (p.20)

50 Recording indicator

51 Recording time/Remaining recording time

*1 G900SE only

Playback Screen

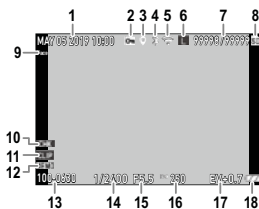

Still image mode

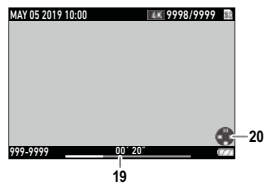

Movie mode





- 1 Shooting date and time
- 2 Image protection (p.85)
- 3 GPS information (p.114)
- 4 Bluetooth® communication (p.96) *1
- 5 Wireless LAN communication (p.96) *1
- 6 Recorded pixels (p.62)
- 7 Current file/Total files
- 8 Data source
- 9 Face detection (p.50)
- 10 Edit detection (p.67)
- 11 Image clip (p.77)

- 12 Camera memo (p.72)
- 13 Folder number/File number (p.118)
- 14 Shutter speed
- 15 Aperture value
- 16 ISO setting
- 17 Exposure compensation
- 18 Battery level (p.20)
- 19 Length of time of the recorded movie/
Elapsed time
- 20 Operation guide

*1 G900SE only

Battery Level

The icon display changes depending on the battery level.

	The battery level is sufficient.
	The battery level started to drop.
	The battery level is low. Charge the battery.
	The camera will turn off soon.
	There is a problem with the battery.

Changing the Screen Display

You can switch the information displayed on the screen by pressing **OK**.

Shooting Mode

The information displayed on the shooting screen can be switched.

Standard information display	Displays the standard information such as shooting settings and electronic level.
Detailed information display	Displays the standard information, electronic compass information, and GPS information.
Grid guide display	Displays the grid guide. Autofocus frame is displayed during range-finding.
No information display	Displays the autofocus frame during range-finding.
Display off	Displays the autofocus frame and Live View only when SHUTTER is pressed halfway.



Memo

- The grid style can be selected in [Grid Guide Display Op.] of the **C** menu. (p.109)

Playback Mode

You can switch the screen display between “Standard information display”, “Detailed information display”, and “No information display” in the single image display.

Use ▲▼ to switch the page in “Detailed information display”.

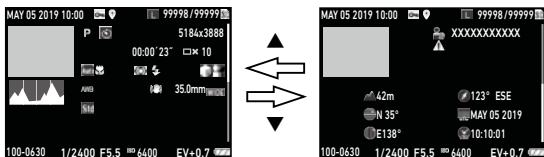

Memo

- The displayed information differs between still images and movies.
- For images to which the following functions have been set, the content of each function is displayed after “No information display”.
 - Camera Memo (p.68)
 - Watermark Options (p.73)
 - Image Clip (p.75)

How to Change Function Settings

Using the Button

1

Introduction

Using the Direct Keys

Quick settings are possible by pressing ▲▼◀▶ in the shooting mode. The following functions can be activated.

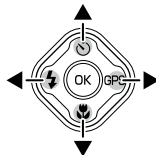

▲ (📷)	Drive Mode (p.58)
▼ (📷)	Focus Mode (p.49)
◀ (📷)	Flash Mode (p.54)
Press and hold ▶ (GPS)	GPS On/Off (p.114)



Memo

- The functions mentioned above can be set from the menu by pressing **MENU**.

Using the ADJ. Button

The registered functions can be easily recalled by pressing **ADJ.**.
When [Camera Memo] is set to [On] in the **ME** menu, change the setting to [Off], and then use **ADJ.** (p.69)

- 1 Press **ADJ.** in the shooting mode.
The mode switches to the ADJ. mode and the icons for the assigned functions appear.

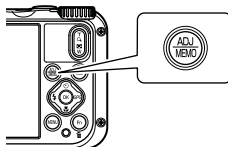

- 2 Use **◀▶** to select a function.
The five functions assigned to the button can be selected.



- 3 Press **OK.**
The selected function is set and the camera is ready to perform shooting.

Memo

- The ADJ. mode functions can be changed in [ADJ Button Setting 1] to [ADJ Button Setting 5] of the **C** menu. (p.107)

Using the Fn Button

The registered function can be activated by pressing **Fn** in the shooting mode.
By default, [Outdoor View] is activated when **Fn** is pressed. (p.110)

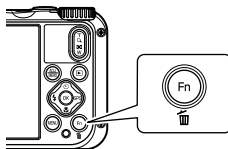

Memo

- The function of **Fn** can be set in [Fn Setting] of the **C** menu. (p.108)

Setting from the Menu

Most functions are set from the menus.





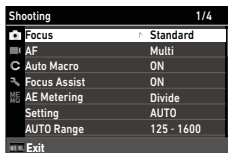

1 Press **MENU**.

The  menu appears.

The menu displayed differs depending on the camera status.

2 When changing the menu type, press **◀**, and use **▲▼** to select a type.



	Shooting menu (p.26) This menu is displayed only in the shooting mode.
	Movie menu (p.27) This menu is displayed only in the shooting mode.
	Playback menu (p.28) This menu is displayed only in the playback mode.
	Customize menu (p.29)
	Setup menu (p.30)
	Expanded Settings menu (p.31)
	Network menu (p.32) This menu is displayed only for G900SE.

3 Press **▶**.

4 Use **▲▼** to select a function to set, and press **▶**.

The settings for the selected setting item are displayed.

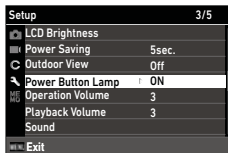

5 Use ▲▼ to select a setting, and press **OK**.

The screen in Step 4 reappears.

Press **MENU** to return to the previous screen.

When you have finished setting, press **MENU** several times to return to previous screens.

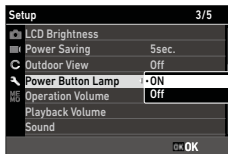

Memo -----

- When **MENU** is pressed, the top screen of the menu or menu appears. To display the last used menu screen first, set [Cursor Position Keeping] to [On] in the menu.
- You can make settings so that the menu is displayed only when **MENU** is pressed and held for about 2 seconds to prevent misoperation. The settings can be made in [Menu Button Setting] of the menu.
- The setting is saved even after the power is turned off. To reset the menu settings, select a menu type to reset in [Initialized Setting] of the menu, and execute [Reset] in the menu.
- You can set a password so that other people cannot change camera settings. (p.129)

Menu List

The following menus are available. (The underlined settings and the square-bracketed settings are the default settings.)

Shooting Menu

Focus	<u>Standard</u> , Macro, 1cm Macro, PF, Infinity, MF	p.49
AF	<u>Multi</u> , Spot, Tracking	p.50
Auto Macro	<u>On</u> , Off	p.49
Focus Assist	<u>On</u> , Off	p.50
AE Metering	<u>Divide</u> , Center, Spot	p.52
Setting	<u>AUTO</u> , 125 to 25600	p.53
AUTO Range	125 - 200, 125 - 400, 125 - 800, <u>125 - 1600</u> , 125 - 3200, 125 - 6400	
EV Comp.	-2.0 to +2.0	p.46
Flash Mode	<u>Auto</u> , Flash Off, Flash On, Auto+R. eye, On+Red-eye, Ring Light	p.54
White Balance	<u>Auto WB</u> , Daylight, Shade, Cloudy, Fl. DL Color, Fl. DL White, Fl. Cool Wt., Fl. Warm Wt., Tungsten, Ring Light, Manual WB	p.56
Pix. Track SR	<u>On</u> , Off	p.65
Face Detection	<u>On</u> , Smile, Assist, Assist+Smile, Off	p.50
Blink Detection	<u>On</u> , Off	p.42
Digital Zoom	<u>On</u> , Off	p.43
Drive Mode	<u>Off</u> , Self-timer, Cont. Shoot, Burst Shoot, M-Cont, S-Cont, Remote Ctl, A-Bracket	p.58
Ring Light	Select: <u>All</u> , Right, Left, High, Low, Off Brightness: 1 to 9 [5] LightningTime: Always On, <u>Shutter 10s</u> , Shutter 20s, Shutter 30s, Shutter 60s	p.55
Recorded Pixels	<u>L</u> , M, S, XS, VGA	p.62
Aspect Ratio	<u>4:3</u> , 3:2, 1:1	
Quality Level	☆☆☆☆, ☆☆☆, ☆☆	
Image Tone	<u>Bright</u> , Natural, Vibrant, Slide Film, Monochrome	
D-Range Setting	Highlight Cor.: <u>Auto</u> , Off Shadow Cor.: <u>Auto</u> , Off	p.65

Sharpness	Soft, <u>Standard</u> , Hard	p.64
Saturation	Soft, <u>Standard</u> , Hard	
Tone Adjustment	Blue, <u>Black & White</u> , Sepia	
Contrast	Soft, <u>Standard</u> , Hard	
Date Imprint	Date, Date & Time, Time, <u>Off</u>	p.64
IQ Enhancer	<u>On</u> , Off	p.64

■ Movie Menu

Recorded Pixels	4K 30fps, <u>FullHD 30fps</u> , HD 60fps, HD 30fps	p.62
HDR	On, <u>Off</u>	
Microphone	<u>On</u> , Off	
Wind Suppression	On, <u>Off</u>	
Movie SR	<u>On</u> , Off	p.65
Movie SR+	On, <u>Off</u>	

 **Playback Menu**

Image Copy	[Internal M]>>>[Card], [Card]>>>[Internal M]	p.84
Protect	1 File, Sel. Multiple, Select All, Cancel All	p.85
Rotation	0°, 90° (counterclockwise), 180°, 90° (clockwise)	p.81
Slideshow	Interval: 30sec., 20sec., 10sec., 5sec., 3sec. Screen Effect: <u>W</u> ipe, Checker, Fade, Random, Off Sound Effect: <u>O</u> n, Off	p.80
Recover File	—	p.84
Resize	Recorded Pixels: L, M, S, XS, 2M, 1M, VGA Quality Level: ☆☆☆☆, ☆☆☆, ☆☆	p.86
Cropping	—	p.87
Filter	Small Face Filter: 5%, 7%, 10% Ink Rubbing Filter: 1 to 5 Digital Filter: <u>B</u> &W/ <u>S</u> epia, Toy Camera, Retro, Color, Extract Color, Color Emphasis, High Contrast, Starburst, Soft, Fish-eye, Miniature, Brightness HDR Filter	p.88
Movie Edit	Save as Still Image, Divide Movies, Adding title picture	p.89
Red-eye Edit	—	p.91
Start-up Screen	<u>Start-up screen with operation guide</u> , RICOH, Photographs, Off	p.109
Auto Image Rotation	<u>O</u> n, <u>O</u> ff	p.81
Skew Correction	—	p.66
File Send (G900SE only)	—	p.101

C Customize Menu

Reg. USER	U1, U2	p.105
CALS Pixels	L, M, S, XS, 2M, 1M, VGA	p.44
CALS Quality	☆☆☆☆, ☆☆☆, ☆☆	
ADJ Button Setting 1 ADJ Button Setting 2 ADJ Button Setting 3 ADJ Button Setting 4 ADJ Button Setting 5	Off, EV Comp., [Setting1], Recorded Pixels [Setting2], Aspect Ratio [Setting3], Setting [Setting4], White Balance [Setting5], Image Tone, Quality Level, AE Metering, AF, Face Detection, Highlight Cor., Shadow Cor., Outdoor View	p.107
Fn Setting	Off, EV Comp., Recorded Pixels, Quality Level, Aspect Ratio, White Balance, Setting, AF, Face Detection, Auto Macro, AE Metering, Highlight Cor., Shadow Cor., Sharpness, Saturation/Tone Adjustment, Contrast, <u>Outdoor View</u>	p.108
START DATE/TIME	<u>On</u> , Off	p.109
Show folder at startup	<u>On</u> , Off	
Shut-down Screen	<u>On</u> , Off	
Confirm. Time	<u>0.5sec.</u> , 1sec., 2sec., 3sec., HOLD, Off	p.42
Quick Zoom	On, <u>Off</u>	p.43
Grid Guide Display Op.		p.109
GPS	On, <u>Off</u>	p.114
GPS Disp Mode	<u>LAT/LON</u> , UTM, MGRS	
GPS Lock	On, <u>Off</u>	
GPS Time Adjustment	On, <u>Off</u>	p.115
GPS Log	Record log: Logging Interval, Logging Duration Save log data: NMEA, KML Discard log data	p.115
Compass Heading	<u>Off</u> , Cardinal, Degrees, Cardinal/Deg.	p.117
Compass Calibration	—	
Declination	<u>TRUE</u> , MAG	
Level Setting	Off, <u>Level + Shift</u> , Level	p.109
Calibrate Level	Reset Calibration	
Data Imprint	GPS Data Imprint: LAT/LON, UTM, MGRS, <u>Off</u> UTC Data Imprint: On, <u>Off</u> Heading Data Imprint: On, <u>Off</u>	p.117
Lens Adapter On	<u>Off</u> , WIDE	p.133

Setup Menu

1

Introduction

Format [Card]	—	p.40
Format [Internal M]	—	
New folder options	<u>Standard</u> , Date, Custom	p.118
File name	<u>Standard</u> , Custom	p.120
File Sequence No.	<u>On</u> , Off	p.121
Reset File Number	—	p.121
Embed Info	<u>On</u> , Off	p.122
Copyright Info	A freely defined string of 32 characters	
Copyright Print	<u>On(OVR)</u> , <u>On(New)</u> , <u>Off</u>	p.123
Copyright Position	<u>Left</u> , Middle, <u>Right</u>	
Copyright Font Size	Large, Middle, <u>Small</u>	
Copyright Color	<u>Orange</u> , White, Black, Red, Blue, Green, Yellow	
Guide Display	<u>On</u> , Off	p.46
Cursor Position Keeping	<u>On</u> , Off	p.25
LCD Brightness	-4 to +4	p.110
Power Saving	Off, <u>5sec.</u> , 15sec., 30sec., 1min., 2min.	p.111
Outdoor View	-2 to +2	p.110
Power Button Lamp	<u>On</u> , Off	p.110
Operation Volume	Off, 1 to 5 [3]	p.110
Playback Volume	Off, 1 to 8 [5]	
Sound	Startup Sound, Shutter Sound, Operation Sound, Self-timer Sound	
Auto Power Off	<u>1min.</u> , 3min., 5min., 10min., 30min., Off	p.111
Monitor Auto off Delay	<u>Off</u> , 1min., 5min., 30min.	p.111
Power Button Hold Op.	<u>On</u> , Off	p.39
Certifications	—	p.3
Version Info	—	—
Camera Settings File	<u>Write</u> , Read	p.106
USB Connection	<u>MSC</u> , MTP, CD-ROM	p.92
HDMI Out	<u>AUTO</u> , 2160P (4K), 1080i, 720P, 480P	p.82
FlashAir Connection	<u>On</u> , Off	p.35

Language/言語	English, French, German, Spanish, Portuguese, Italian, Dutch, Danish, Swedish, Finnish, Polish, Czech, Hungarian, Turkish, Greek, Russian, Thai, Korean, Traditional Chinese, Simplified Chinese, Japanese	p.40
Date Adjustment	Date Format: Y/M/D, D M Y, M D Y Date: January 1, 2019 to December 31, 2045 Time: 00:00 to 23:59	p.40
World Time	World Time: <u>Hometown</u> , Destination Hometown: City, DST Destination: City, DST	p.124
Initialized Setting	Still, Movie, Playback, Customize, Setup, Quality	p.25
Reset	—	

Expanded Settings Menu

Camera Memo Options	<u>On</u> , Off	p.68
Camera Memo Mode	<u>Mode1</u> , Mode2, Mode3, Mode4	p.125
Memo Skip	Item 1, <u>Item 2</u> , Item 3, Item 4, Item 5	
Mark Memo Added	On, <u>Off</u>	
Remove Memo Marking	—	
Memo Warning	On, <u>Off</u>	
Memo at Startup	On, <u>Off</u>	
Memo Increment	On, <u>Off</u>	
Camera Memo Imprint	On, <u>Off</u>	
Memo 1 Auto Delete	On, <u>Off</u>	
Memo Overwrite	<u>On</u> , Off	
10 Keyboard	<u>On</u> , Off	
Barcode Mode	<u>Mode1</u> , Mode2, Mode3, Mode4, Mode5, Mode6, Mode7, Mode8	p.126
Barcode Type	<u>AUTO</u> , 1D Barcode, QR Code, Micro QR, DataMatrix, PDF417, Micro PDF417, MaxiCode, EAN.UCC, Aztec	
Scan Time	<u>3sec.</u> , 6sec., 9sec., 12sec., 15sec., 18sec., 21sec., 24sec., 27sec., 30sec.	
Barcode LED	<u>On</u> , Off	
Set/Edit User PW	<u>Keyboard</u> , Barcode, NFC (G900SE only)	p.129
Camera User Lock Op.	<u>Off</u> , Camera, Int. Memory, SDWO (G900SE only), Menus, USB	p.130

Set/Edit Admin. PW	<u>Keyboard</u> , Barcode, NFC (G900SE only)	p.129
Camera Admin. Lock	<u>Off</u> , Camera, Int. Memory, SDWO (G900SE only), Menus, USB, WEB (G900SE only)	p.130
PW Validity Period	<u>Off</u> , 1min., 15min., 30min., 60min.	p.132
Set/Edit SD Card PW	—	p.131
Card PW Unlock Time	<u>Off</u> , 1min., 15min., 30min., 60min.	p.132
Image Clip	Image Clip: <u>On</u> , <u>Off</u> Flag Function Quality: 3M, 2M, 1M, <u>VGA</u>	p.75
Board	<u>On</u> , <u>Off</u>	p.71
Image Composite Sett.	Image Composite Sett.: <u>Off</u> , Board, Image Clip Composite Position: Upper Left, Upper Right, Bottom Left, <u>Bottom Right</u> Composite Size: <u>Large</u> , Middle, Small	p.77
Edit Detection	<u>Off</u> , <u>On</u>	p.67
Restore Defaults	Reset: <u>On</u> , <u>Off</u> Size: <u>L</u> , M, S, XS, 2M, 1M, VGA Aspect Ratio: <u>4:3</u> , 3:2, 1:1 Quality Level: ☆☆☆☆, ☆☆☆, ☆	p.62
Menu Button Setting	<u>On</u> , <u>Off</u>	p.25
Skew Correct Frame	<u>On</u> , <u>Off</u>	p.66
Template	—	p.73
Transparency	<u>80%</u> , 60%, 40%, 20%	p.74

Network Menu (G900SE Only)

Communication Mode	<u>Off</u> , Wireless LAN, Bluetooth, WLAN/BT	p.96
Import Com. Setting	—	p.98
Send To	Network Wireless LAN Setting FTP/FTPS Server Options Web Server Options Auto Update Server Options 802.1x Authentication	
Send Status	<u>On</u> , <u>Off</u>	
Simple Connection	<u>Off</u> , WPS Button, WPS PIN, Scan, Connection Inf	
OSS Information	—	—

Bluetooth Connection	<u>BLE</u> , Classic	p.100	
Bluetooth Serial	—		
Bluetooth Pass Key	—		
Bluetooth Search Ct	1 to 10 [5]		
Bluetooth SPP Conn	<u>On</u> , <u>Off</u>		
Bluetooth Mas/Slav	Master, <u>Slave</u>		
Bluetooth PF	<u>OPP</u> , <u>BIP</u> , <u>OPP/BIP</u>		
Bluetooth Shutter	<u>On</u> , <u>Off</u>	p.97	
Bluetooth Device Sett.	<u>Off</u> , BC Reader, GPS, Range finder	p.100	
Range Finder Mode	<u>Mode1</u> , <u>Mode2</u> , <u>Mode3</u>		
Quick Send Mode	<u>Off</u> , 1Touch, 2Touch, AUTO	p.102	
Image File Size	<u>Off</u> , 1/2, 3M, 2M, 1M, <u>VGA</u>	p.96	
Auto Delete	<u>On</u> , <u>Off</u>		
Transmit Power Off	<u>Off</u> , Still, Still/Movie		
Connection Power On	<u>On</u> , <u>Off</u>		
NFC	<u>On</u> , <u>Off</u>		p.128
NFC Setting	Security: <u>On</u> , <u>Off</u> DB Co-op: <u>On</u> , <u>Off</u>		
Server Sync.	Synchronize Clock: <u>Off</u> , <u>On</u> , Manual Update Firmware: <u>Off</u> , <u>On</u> , Manual Update Settings: <u>Off</u> , <u>On</u> , Manual	p.103	
Support	Create Log File: <u>On</u> , <u>Off</u> Append CRC: <u>On</u> , <u>Off</u> Number of Retries: <u>Off</u> , 1 Retry, 2 Retries, 3 Retries, 4 Retries, 5 Retries AP Connection Timeout: <u>Off</u> , <u>15sec.</u> , 30sec., 60sec., 90sec. PING Operation Log: <u>On</u> , <u>Off</u> Retain WLAN Conn.: <u>On</u> , <u>Off</u>	p.103	

Setting the Battery and a Memory Card

Inserting the Battery and a Memory Card

2

Getting Started

SD memory cards, SDHC memory cards, and SDXC memory cards can be used with this camera. "Memory card" refers to these memory cards in this manual.

1 Make sure that the camera power is off.

2 Slide the release lever on the bottom of the camera toward OPEN, and slide the battery/card cover to the right to open it.

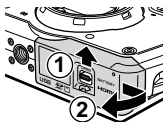

3 Make sure that the memory card is facing the right way and then push the card all the way in until it clicks.

To remove it, press in the memory card and then release your hand.

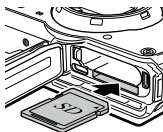

4 Insert the battery.

Use the rechargeable battery (DB-110) to press the latch and insert the battery all the way into the battery compartment.

To remove the battery, slide the latch.

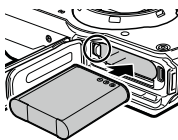

5 Close the battery/card cover and slide it to the left.

Slide the battery/card cover until it clicks and confirm that it is closed securely.

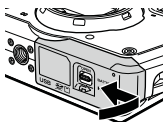

**Caution**

- When opening and closing the battery/card cover, be sure to remove water and dirt such as sand adhering to the camera, and avoid locations where dirt can enter the camera interior.
- Close the battery/card cover securely. If the battery/card cover is not closed securely, water or dust may enter the camera interior.

Data Storage Location

Images captured and movies recorded with this camera are saved in the internal memory or a memory card.

**Memo**

- Saved images can be copied between the internal memory and the memory card. (p.84)
- The storage capacity varies depending on the memory card. (p.146)

**FlashAir Card**

- An SD memory card with a built-in wireless LAN function (FlashAir card) can be used with the camera. When communicating using the FlashAir card, set [FlashAir Connection] to [On] in the  menu. If the write-protect switch of the FlashAir card is locked, the settings cannot be made.
- Use of an access point and an Internet connection are required for transferring images via a wireless LAN. For details, refer to the card manufacturer's website, etc.
- The operability of FlashAir card functions including the wireless transmission function is not guaranteed with this camera. Contact the FlashAir card manufacturer regarding any malfunctions or problems concerning FlashAir cards. FlashAir cards can be used only in the country in which the card was purchased. For details, contact the FlashAir card manufacturer.

**Tamper-proof Card**

- For the G900SE, the tamper-proof card can be used.
- Once you have recorded images in the tamper-proof card, you cannot perform the following operations.
 - Delete
 - Image Copy
 - Protect
 - Recover File
 - Resize
 - Cropping
 - Filter
 - Movie Edit
 - Red-eye Edit
 - Skew Correction
 - Format
- A limited number of folders can be created in a tamper-proof card. For the number of folders and files that can be created, contact the card manufacturer.
- The files in the tamper-proof card cannot be copied to a computer via a USB cable.

Charging the Battery

Charge the provided rechargeable battery DB-110 before using the camera. Use the provided USB cable, USB power adapter, and power plug to charge the battery with the battery charger or camera.

- 1** Insert the power plug to the USB power adapter.

Insert it until it clicks into place.

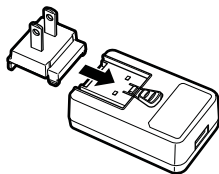

- 2** Insert the battery to the battery charger, and connect the USB cable to the USB terminal.

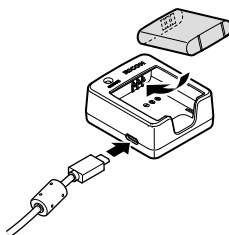

When charging the battery with the camera, open the battery/card cover, and connect the USB cable to the USB terminal with the battery inserted.

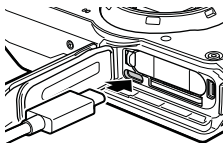

2

Getting Started

- 3** Connect the USB cable to the USB power adapter.

- 4** Plug the USB power adapter into a power outlet.

The indicator lamp of the battery charger or the power button lamp of the camera turns on, and charging starts.

Depending on the battery level, the charging time differs.

When charging is complete, the indicator lamp or power button lamp turns off.

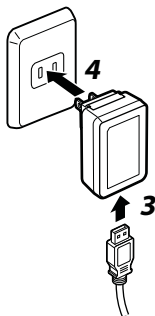

- 5** Remove the USB cable from the USB terminal, and close the battery/card cover.

- 6** Unplug the USB power adapter from the power outlet.



Storage Capacity

- About 340 pictures can be taken when the battery is fully charged.
- This is based on tests conducted according to CIPA standards under the following conditions: At 23°C (73°F) temperature; the monitor is on; a picture is taken every 30 seconds; the flash is fired every two pictures; the camera is turned off and back on after 10 pictures are taken.
- The storage capacity is for reference. For long periods of use, it is recommended that you carry spare batteries.



Caution

- When opening and closing the battery/card cover, be sure to remove water and dirt such as sand adhering to the camera, and avoid locations where dirt can enter the camera interior.
- Use only genuine rechargeable battery (DB-110).
- If the battery starts to run down more quickly even after being charged, the battery has reached the end of its service life. In this case, replace the battery with a new one.
- The battery may become very hot immediately after operation. Turn the camera off and leave it to cool down sufficiently before removing the battery.



Memo

- You can also charge the battery by connecting the camera to a computer using the USB cable.

Initial Settings

Turn the camera on and make the initial settings.

Turning the Camera On

1 Press the power button.

The power button lamp turns on.

The first time the camera is turned on after purchase, the [Language/言語] screen appears.

When the power button is pressed again, the power turns off.

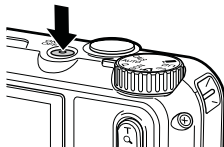





2

Getting Started



Memo

- When  is pressed and held with the camera turned off, the camera turns on in the playback mode.
- The power button lamp can be set to [Off] in [Power Button Lamp] of the  menu. (p.110)
- If no operations are made for about one minute (default setting), the camera turns off automatically to suppress battery drain. The power saving function can be set in the  menu. (p.111)
- The display of the start-up screen can be set in [Start-up Screen] of the  menu. (p.109)
- You can also make settings so that the camera is turned on and off by pressing and holding the power button to prevent misoperation. When [Power Button Hold Op.] is set to [On] in the  menu, press and hold the power button for about 2 seconds to turn the camera on, and press and hold for about 5 seconds to turn the camera off.



Protecting the Camera with a Password

- You can set the camera to require a password input when it is turned on. (p.129)

Setting the Language and the Date and Time

You can set the display language for menus and the date and time.

1 Use ▲▼ to select a language, and press **OK**.

The selected language is set and the [Date Adjustment] screen appears.

2 Set the display format and the date and time.

Use ◀▶ to select an item and ▲▼ to change the value.

Press **MENU** to cancel the setting.

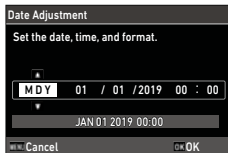

3 Press **OK**.

The date and time are set and the camera is ready to take a picture.



Memo

- If the battery is removed for about five days, the date and time settings will be lost. To retain the date and time settings, insert a battery with sufficient power for at least two hours, and then remove the battery.
- You can change the language and the date and time settings in the menu.

Formatting a Memory Card

When using a new memory card or a memory card used with another device, be sure to format the memory card with this camera. The internal memory can also be formatted with the same operations.

If a memory card is formatted, the folders required to save camera memos and communication lists are created.

1 Press **MENU**.

The menu appears.

2 Press **◀**, and use **▲▼** to select **↶**.

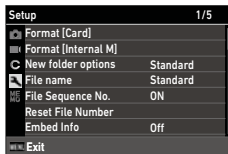

3 Press **▶**, select **[Format [Card]]**, and press **▶**.

When formatting the internal memory, select **[Format [Internal M]]**.

4 Use **▲** to select **[Execute]**, and press **OK**.

The memory is formatted.



5 Press **OK**.

6 Press **MENU**.

The shooting screen reappears.



Caution -----

- Do not remove the memory card while formatting, or the card may be damaged.
- Formatting deletes all data, both protected and unprotected. However, the following files are not deleted.
 - Camera memo file
 - Board file
 - Camera settings file
- Do not format FlashAir cards with this camera.

Basic Shooting Operation

Shooting in the Auto Mode

The camera automatically selects the optimal capture mode.

2

Getting Started

1 Set the mode dial to **AUTO**.

The capture mode is set to **AUTO**, and the Live View is displayed.

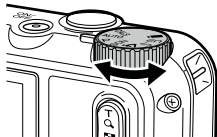

2 Use **Q** (T)/**W** to change the zoom magnification.

The optical zoom up to 5x magnification is available. The digital zoom up to 40.5x magnification is available by further pressing **Q**.

3 Press **SHUTTER** halfway.

The capture mode is selected, and the focus is adjusted.

When the subject cannot be in focus, the red frame appears.

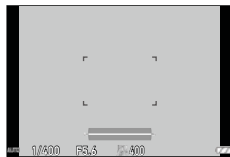

4 Press **SHUTTER** fully.

The image you have just captured is displayed on the monitor (Instant Review) and saved.



Instant Review and Blink Detection

- You can set the display time of Instant Review in [Confirm. Time] of the **C** menu. When set to [HOLD], the Instant Review is displayed until **SHUTTER** is pressed halfway or the mode dial is turned.
- If the camera detects that the subject's eyes are closed, the message [Closed eyes have been detected] appears during Instant Review. You can also set [Blink Detection] to [Off] in the **Q** menu to disable this function.



Zoom

- When **Q** is pressed and held, the zooming method switches from the optical zoom to the intelligent zoom. If **Q** is release and pressed again, the zooming method switches from the intelligent zoom to the digital zoom with up to 40.5x magnification. The digital zoom magnification varies depending on the [Recorded Pixels] settings in the **C** menu.
- The quality of images captured with the digital zoom slightly deteriorates. You can set whether to use the digital zoom in [Digital Zoom] of the **C** menu.

Viewing the Captured Images

Review the captured image on the monitor.

1

Press **Q**.

The camera switches to the playback mode and the last image you took is displayed. (Single image display)

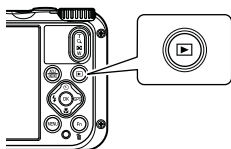
**2**

View an image.

The following operations are available.

◀▶	Displays the previous or next image.
Press and hold ◀▶	Fast-reverses/Fast-forwards playback.
▲▼	Reverses/Forwards playback by 10 frames.
🗑️	Deletes the image.
Q (T)	Magnifies the image.
W (W)	In magnified view: Reduces the image.
▲▼◀▶	In magnified view: Moves the magnified area.
OK	Switches the displayed information.
MEMO	Displays the camera memo. (p.72)



Memo

- Movies cannot be magnified.
- When [Quick Zoom] is set to [On] in the **C** menu, pressing **Q** once magnifies the image at the maximum magnification.

Taking Pictures

Taking Still Images

Setting the Capture Mode

Turn the mode dial to select capture modes.

3

Taking Pictures

CALS CALS Mode	Takes images with the recorded pixels and quality level set in [CALS Pixels] and [CALS Quality] of the C menu. The aspect ratio is fixed to [4:3]. By default, the recorded pixels are set to [1M] and the quality level is set to [☆☆☆]. These settings are appropriate to take construction site pictures submitted to local authorities.
AUTO Auto Mode	Takes images with the optimal capture mode automatically selected by the camera. (p.42)
P Program Mode	Takes images with the shutter speed and aperture value automatically set by the camera.
SCN Scene Mode	Selects a scene from various scenes and takes images with the optimal settings for the selected scene. (p.45)
♫ Digital Microscope Mode	Turns the ring light on for shooting at a close focus distance of 1 cm to the subject. The focus mode, flash mode, recorded pixels, and aspect ratio are fixed to [1cm Macro], [Ring Light], [XS], and [4:3], respectively. You can fix the distance to the subject to 1 cm by attaching the provided macro stand (p.13) to the camera.
U1/U2 User Mode	Uses the saved shooting settings. (p.105)
■ Movie Mode	Records a movie. (p.47)

Performing Shooting in the Scene Mode



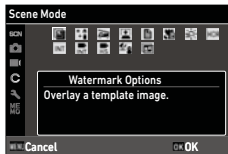











- 1** Set the mode dial to **SCN**.
The mode switches to the **SCN** mode.
- 2** Press **MENU**.
The **SCN** menu appears.
- 3** Use **▲▼◀▶** to select a scene.



3

Taking Pictures

The following scenes can be selected.

 Watermark Options (p.73)	 HDR HDR
 Digital SR	 INT Interval Shooting
 Firefighting	 INT Interval Movie
 Skew Correction (p.66)	 HS High Speed Movie
 Text Mode	 Surf & Snow
 Zoom Macro	 DOF Composite
 Remove Haze	 Image Sync (p.97)

* G900SE only

- 4** Press **OK**.
The scene is set.

**Memo**

- The **SCN** menu is displayed only in the **SCN** mode.
- When the scene is set to [Interval Shooting] or [Interval Movie], shooting is performed at a fixed interval. You can set [Interval], [Number of Shots] ([Total Time] for [Interval Movie]), and [Start Delay].
- A description of the selected scene is displayed on the screen in Step 3. If you do not want to display this description, set [Guide Display] to [Off] in the menu.

**Caution**

- The functions that can be set vary depending on the scene.
- When the scene is set to [HDR] or [DOF Composite], fix the camera using a tripod, etc. during shooting.
- [Interval Shooting] and [Interval Movie] cannot be selected during the GPS logging. (p.115)

Using Exposure Compensation**1**

Select [EV Comp.] in the menu, and press .

The [EV Comp.] screen appears.

2

Use to select a compensation value.

The compensation value can be selected in the range of ± 2.0 .

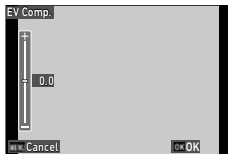
**3**

Press .

4

Press .

The shooting screen reappears.

**Caution**

- The exposure compensation is not available in the **AUTO** mode.

Recording Movies

- 1** Set the mode dial to **MOVIE**.
The mode switches to the **MOVIE** mode.
- 2** Press **SHUTTER** halfway.
Autofocus is performed.
- 3** Press **SHUTTER** fully.
Recording starts.
The recording time is displayed while recording.
- 4** Press **SHUTTER** again.
Recording stops.



Caution

- When [Microphone] is set to [On] (default setting) in the **MOVIE** menu, camera operation sounds are also recorded.
- If the internal temperature of the camera becomes high during recording, recording may be terminated.
- The flash cannot be used in the **MOVIE** mode.
- You can record a movie continuously up to 4 GB or 25 minutes. Recording stops when the memory card or internal memory becomes full. The maximum recording time per shooting depends on the capacity of the memory card. (p.146) Shooting may stop even before the maximum recording time is reached.
- The amount of time remaining is calculated based on the amount of memory available and may not diminish at an even rate.
- For the memory cards with which proper operation has been confirmed for recording movies, refer to p.147.
- The use of the battery with sufficient power is recommended.

Playing Back Movies

1 Press .







An image is displayed in the single image display of playback mode.

2 Use to select a movie to play back.

The first frame of the movie is displayed as a still image.

3 Play back a movie.

The following operations are available.



	Plays back/Pauses a movie.
 	Fast-reverses/Fast-forwards playback.
	Stops playback.
 (T) /  (W)	Adjusts the sound volume.
	Switches the displayed information.

3

Taking Pictures



Memo

- The sound volume at the start of movie playback can be set in [Playback Volume] of the  menu.
- In [Movie Edit] of the  menu, you can divide a movie file into multiple segments and add a title image to a movie. (p.89)

Setting the Focus Mode

1 Press (▼) in the shooting mode.

The [Focus Mode] screen appears.

2 Use ▲▼ to select a setting.

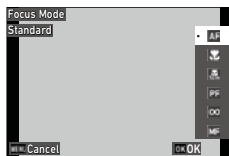

 Standard	Focuses on the subject at a distance of 50 cm or more from the camera when SHUTTER is pressed halfway. When [Auto Macro] is set to [On] (default setting) in the menu, focusing is also performed for subjects in the macro range.
 Macro	Focuses on the subject at a distance of 10 to 60 cm from the camera.
 1cm Macro	Focuses on the subject at a distance of 1 to 30 cm from the camera.
 PF	Focuses on the entire picture, from the front to the back.
 2.5m	Focuses at a distance of 2.5 m. [2.5m] can be selected only when [Firefighting] is selected in the SCN mode.
 Infinity	Fixes the focus distance at infinity. This is useful for shooting distant scenes.
 MF	Focuses manually. (p.51)

3 Press **OK**.

The shooting screen reappears.

Memo -----

- The focus mode can also be set in [Focus] of the menu.
- The autofocus method for the still image mode can be set in [AF] of the menu.

Multi	Measures the distances from 3×3 AF areas and focuses to the nearest AF area. (Default setting)
Spot	Focuses to the center AF area.
Tracking	Keeps focusing while SHUTTER is pressed halfway

- Faces of people (up to 30 people) are automatically detected during autofocusing. The detection method can be selected in [Face Detection] of the menu.

On	Detects human faces.
Smile	Automatically performs shooting when the subject smiles.
Assist	Flashes the ring light when a human face is detected. The position of flashing ring light LED indicates where the face is detected within the angle of view.
Assist+Smile	Flashes the ring light when a human face is detected and automatically performs shooting when the subject smiles.
Off	Does not detect human faces.

- The AF assist light on the front of the camera lights as necessary during autofocusing. The AF assist light can be set to [Off] in [Focus Assist] of the menu.
- When [Firefighting] is selected in the **SCN** mode, select the focus mode from [Standard], [2.5m], [Infinity], and [MF].

Focusing Manually (Manual Focus)

If the camera fails to focus automatically, you can focus manually. The manual focus enables shooting at a fixed distance.

- 1 Select [MF] in Step 2 on p.49, and press **OK**.
The focus bar appears on the shooting screen.

- 2 Use **▲▼** to set a focus distance.



When **OK** is pressed and held, the center of the screen is magnified. Pressing and holding **OK** again restores the normal display.





Memo

- When changing the focus mode from [MF], change the mode in [Focus] of the menu.

Setting the Exposure

Selecting a Metering Method

Set the metering method in [AE Metering] of the  menu.

 Divide	Meters exposure in multiple areas of the frame.
 Center	Meters exposure with emphasis on the center.
 Spot	Meters exposure within a narrow range. Use this option when metering exposure in a part of an image or when the metering target subject is small.

3

Taking Pictures

Setting the ISO Sensitivity

- 1 Select [Setting] in the  menu, and press .
- 2 Use   to select a setting.

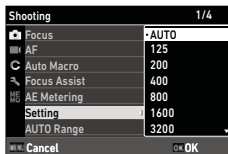

- 3 Press **OK**.
- 4 Press **MENU**.
The shooting screen reappears.



Memo

- Values that can be set differ depending on the capture mode. [Setting] cannot be set in the following **SCN** modes.
 - [Digital SRI], [Firefighting], [Interval Movie], [High Speed Movie]
 - [HDR] ([Setting] is fixed to [AUTO])
- For the shooting with [Setting] set to [AUTO] and the shooting in [HDR] of the **SCN** mode, the adjustment range of [AUTO] can be set in [AUTO Range] of the  menu. In the **CALS** mode, [AUTO Range] cannot be set.



Caution

- Images captured with a higher sensitivity may appear grainy.
- Depending on the ISO sensitivity setting, the setting of [D-Range Setting] of the  menu is disabled.





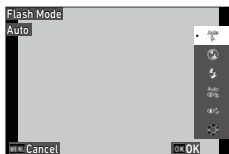

Using the Flash

- 1** Press  (◀) in the shooting mode.

The [Flash Mode] screen appears.

- 2** Use ▲▼ to select a setting.



 Auto	Fires the flash according to conditions.
 Flash Off	Does not fire the flash.
 Flash On	Always fires the flash.
 Auto+R. eye	Fires the flash according to conditions while reducing the red-eye phenomenon.
 On+Red-eye	Forces the flash to fire while reducing the red-eye phenomenon.
 Ring Light	Turns on the ring light around the lens.

- 3** Press .

The shooting screen reappears.



Memo

- The flash mode can also be set in [Flash Mode] of the menu.



Caution

- You cannot perform shooting while the flash is being charged.
- The flash cannot be used in the mode.

Using the Ring Light

Select [Ring Light] in Step 2 on p.54 and press to set the brightness of the ring light. The settings for the ring light can be made in [Ring Light] in the menu.

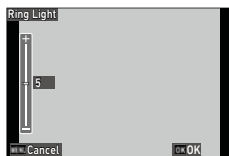

Select	[All], [Right], [Left], [High], [Low], [Off]
Brightness	[1] to [9]
LightningTime	[Always On], [Shutter 10s], [Shutter 20s], [Shutter 30s], [Shutter 60s]



Caution

- [Ring Light] cannot be selected in the following cases.
 - In the **AUTO** mode, **SCN** mode, or mode

Setting the White Balance







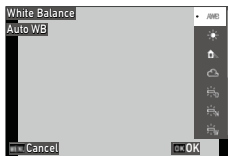

Make adjustments to the white balance so that white subjects will appear white under any kind of light.



1 Select [White Balance] in the  menu, and press **▶**.

The [White Balance] screen appears.

2 Use **▲▼** to select a setting.



 Auto WB	Adjusts the white balance automatically.
 Daylight	Used when shooting in daylight under clear skies.
 Shade	Used when shooting in shade.
 Cloudy	Used when shooting in daylight under cloudy skies.
 Fl. DL Color	Used with daylight fluorescent lighting.
 Fl. DL White	Used with neutral white fluorescent lighting.
 Fl. Cool Wt.	Used with cool white fluorescent lighting.
 Fl. Warm Wt.	Used with warm white fluorescent lighting.

 Tungsten	Used with incandescent lighting.
 Ring Light	Used when the ring light of the camera is used.
 Manual WB	Set the white balance manually. (p.57)

3 Press **OK**.

4 Press **MENU**.

The shooting screen reappears.



Caution

- The white balance may not be adjusted correctly for a subject that is mostly dark.

Setting the White Balance Manually

1 Select [Manual WB] in Step 2 on p.56.

2 Aim the camera at a white subject, such as a sheet of paper, under the light for shooting.

3 Press **Fn**.

An image to be used for white balance adjustment is captured.

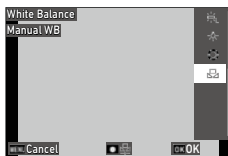



4 Press **OK**.

5 Press **MENU**.

The shooting screen reappears.

Setting the Drive Mode

You can set the drive mode by pressing  (▲) in the shooting mode. The drive mode can also be set in [Drive Mode] of the  menu.

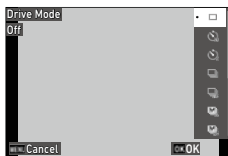



Shooting Using the Self-timer

- 1** Press  (▲) in the shooting mode.

The [Drive Mode] screen appears.

- 2** Use ▲▼ to select a setting.

 Self-Timer 10s	Releases the shutter about 10 seconds after SHUTTER is pressed.
 Self-Timer 2s	Releases the shutter about 2 seconds after SHUTTER is pressed.

- 3** Press **OK**.

The shooting screen reappears.

- 4** Press **SHUTTER**.

The AF assist light blinks during the countdown, and the shutter is released after about 10 seconds or 2 seconds.





Pressing **SHUTTER** halfway during the countdown cancels the self-timer.

Shooting Continuously

1 Press (▲) in the shooting mode.

The [Drive Mode] screen appears.

2 Use ▲▼ to select a setting.



 Cont. Shoot	Performs continuous shooting while SHUTTER is pressed.
 Burst Shoot	Fixes the recorded pixels and aspect ratio to [S] and [4:3], respectively, and performs continuous shooting at high speed.
 M-Cont	Performs continuous shooting while SHUTTER is pressed, and saves last 16 or 25 still images captured for 2 seconds before the button is released as an image of 5184 × 3888 pixels. (Memory retrospective continuous shooting)
 S-Cont	Performs continuous shooting for 16 or 25 still images after SHUTTER is fully pressed, and saves them as an image of 5184 × 3888 pixels. (Streaming continuous shooting)

3 Press **OK**.

The shooting screen reappears.



Caution

- The following functions cannot be used.
 - Flash
 - [On(New)] in [Copyright Print] of the  menu
 - [Image Composite Sett.] of the  menu
- [Cont. Shoot] cannot be selected in the following capture modes.
 - **AUTO** mode
 - [Interval Shooting] in the **SCN** mode
 -  mode

**Memo**

- The focus setting and exposure value are fixed during continuous shooting.
- The maximum number of images that can be captured continuously varies depending on the [Recorded Pixels] setting in the menu.
- The continuous shooting setting is reset when the camera is turned off and on again.
- If you release **SHUTTER** early for [M-Cont], the number of saved images may not reach 16 or 25.
- The images captured with [M-Cont] or [S-Cont] are displayed in 16 or 25 thumbnails in the single image display of mode. Press (T) to display an image in the single image display, and to display the previous or next image.

Shooting Using the Remote Control Unit

You can perform shooting using the optional remote control unit.



1

Press (▲) in the shooting mode.

The [Drive Mode] screen appears.

2

Use ▲▼ to select a setting.

 0s R.Ctl.	Releases the shutter immediately after the shutter release button on the remote control unit is pressed.
 3s R.Ctl.	Releases the shutter about 3 seconds after the shutter release button on the remote control unit is pressed.

3

Press **OK**.

The shooting screen reappears.

4





Point the remote control unit towards the remote control receiver of the camera, and press the shutter release button.

**Memo**

- The maximum operating distance of the remote control unit is about 4 m from the front of the camera and about 2 m from the rear of the camera.

Shooting with Varied Exposure Values

Takes three images with different exposure settings of -1.0 EV, 0 EV, and +1.0 EV.

- 1** Press  (▲) in the shooting mode.
The [Drive Mode] screen appears.
- 2** Use ▲▼ to select [A-Bracket], and press .
The shooting screen reappears.
- 3** Press .
Three images are captured by pressing  once.
The three images are displayed side by side during Instant Review.

Configuring the Capture Settings

Image Capture Settings

Set the file format for still images in the  menu.

Recorded Pixels	[L], [M], [S], [XS], [VGA]
Aspect Ratio	[4:3], [3:2], [1:1]
Quality Level	[☆☆☆☆], [☆☆☆], [☆☆]





Caution

- The settings that can be selected are limited depending on the capture mode.



Memo

- The image capture settings for the **CALS** mode can be made in [CALS Pixels] and [CALS Quality] of the  menu.
- You can reset the still image capture settings to their default values each time the camera is turned on. Set the default values and set [Initialized Setting] to [On] in [Restore Defaults] of the  menu.

Movie Capture Settings

Set the file format for movies in the  menu.

Recorded Pixels	Sets the number of recorded pixels. [4K 30fps] (3840 × 2160) [FullHD 30fps] (1920 × 1080) [HD 60fps] (1280 × 720) [HD 30fps] (1280 × 720)
HDR	Sets whether to perform the HDR recording.
Microphone	Sets whether to record sounds.
Wind Suppression	Reduces wind noise during recording.





Memo

- For the reduction of blurring during recording movies, refer to "Reducing Blurring of Images" (p.65).



Caution

- When [Recorded Pixels] is set to [4K 30fps] or [HD 60fps], [Movie SR+] of the  menu and [HDR] are fixed to [Off].
- [Movie SR+] of the  menu and [HDR] cannot be set simultaneously.

Setting the Image Finishing Tone and Correction







Setting the Image Atmosphere (Image Tone)

You can control the finishing tone for captured images.

1 Select [Image Tone] in the  menu, and press **▶**.

The [Image Tone] screen appears.

2 Use **▲▼** to select a setting.

 Bright	Increases the values of [Contrast], [Sharpness], and [Saturation] to take sharp images.
 Natural	Takes images with a natural tone close to the actual color.
 Vibrant	Takes bright and gorgeous images with a deep tone of color.
 Slide Film	Takes contrast-emphasized images like those captured with a reversal film.
 Monochrome	Takes a black and white image. Set [Tone Adjustment] in the  menu. (p.64)



3 Press **OK**.

4 Press **MENU**.

The shooting screen reappears.

Setting the Sharpness, Saturation, Tone, and Contrast

The following settings can be made in the  menu.

Sharpness	[Soft], [Standard], or [Hard] can be selected.
Saturation	[Soft], [Standard], or [Hard] can be selected. [Saturation] can be set only when [Image Tone] is set to other than [Monochrome] in the  menu.
Tone Adjustment	[Blue], [Black & White], or [Sepia] can be selected. [Tone Adjustment] can be set only when [Image Tone] is set to [Monochrome] in the  menu.
Contrast	[Soft], [Standard], or [Hard] can be selected.

Imprinting the Date on Still Images

The date can be imprinted at the bottom right of the image based on the date set in the camera. The date imprinting can be set in [Date Imprint] of the  menu.



Caution

- The imprinted date cannot be deleted.
- The date cannot be imprinted in the following cases.
 - During the shooting in [High Speed Movie] of the **SCN** mode
 - In the  mode
 - When [Drive Mode] is set to [Burst Shoot], [M-Cont], or [S-Cont]
- When [UTC Data Imprint] of [Data Imprint] is set to [On] in the **C** menu, [Date Imprint] is fixed to [Off]. (p.117)

Capturing Images with Clearer Details

Images with clearer details can be captured by image processing. Set in [IQ Enhancer] of the  menu.



Caution

- [IQ Enhancer] is disabled in the following case.
 - When [Drive Mode] is set to [Burst Shoot], [M-Cont], [S-Cont], or [A-Bracket]

Correcting a Range of Tones (D-Range Setting)

With [D-Range Setting] of the  menu, you can expand an image gradation to make the bright and dark portions of an image clearly visible.

Highlight Cor.	Corrects the bright portions of the image.
Shadow Cor.	Corrects the dark portions of the image.



Caution

- When the shooting location is too bright or too dark, the [D-Range Setting] setting may not be effective.

Reducing Blurring of Images

To automatically reduce blurring of images, set the following functions.

Still image mode	[Pix. Track SR] in the  menu
Movie mode	[Movie SR] or [Movie SR+] in the  menu



Memo

- When [Drive Mode] is set to [Self-timer], each setting is fixed to [Off].
- Setting [Movie SR+] to [On] achieves movies with less blurring.



Caution

- [Movie SR] and [Movie SR+] are fixed to [Off] in the following case.
 - When [Interval Movie] or [High Speed Movie] is selected in the **SCN** mode
- [Movie SR+] is fixed to [Off] in the following cases.
 - When [Recorded Pixels] is set to [4K 30fps] or [HD 60fps]
 - When [HDR] is set to [On] in the  menu

Correcting a Rectangular Subject (Skew Correction)

When shooting a rectangular subject such as a signboard at an angle, you can correct it as if it were captured from the front before saving it.

1 Set the mode dial to **SCN**, and then press **MENU**.

2 Select **[Skew Correction]** in the **SCN** menu.

The mode switches to the **[Skew Correction]** mode.

3

3 Shoot.

A yellow frame is displayed for the area recognized as the correction target. If the area cannot be detected, an error message is displayed and the image before correction is saved.

4 Press **▶** to select the area to be corrected.

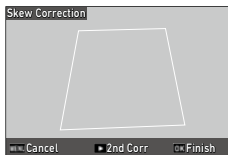

5 Press **OK**.

The images before and after correction are saved respectively.



Memo

- In the **[Skew Correction]** mode, the recorded pixels can be set to **[S]**, **[XS]**, or **[VGA]**. The aspect ratio is fixed to **[4:3]**.
- When **[Skew Correct Frame]** is set to **[On]** in the **M5** menu, a margin is added around the corrected image.
- The saved still images can be corrected with **[Skew Correction]** in the **▶** menu.



Caution

- Shoot the entire subject as large as possible.
- The subject may not be recognized in the following cases.
 - When the subject is not in focus
 - When all sides of the subject are not clearly visible
 - When it is difficult to distinguish between the subject and the background
 - When the background is complicated

Detecting Edited Images

If you set [Edit Detection] to [On] in the **ME** menu before shooting, you can check whether the captured image has been edited after shooting using the dedicated software. For the dedicated software, refer to the RICOH website.

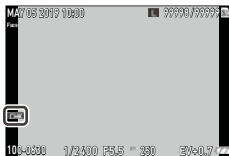

Caution

- When [Edit Detection] is set to [On], saving images takes longer than usual.
- The image processed and edited in the **▶** menu is judged as an edited image.
- [Edit Detection] is fixed to [Off] in the following cases.
 - When [Drive Mode] is set to [Cont. Shoot], [Burst Shoot], [M-Cont], [S-Cont], or [A-Bracket]
 - In the **■** mode
- When an image is captured with [Skew Correction] of the **SCN** mode, [Edit Detection] for the corrected image is set to [Off].
- When [Camera Memo Mode] is set to [Mode4] in the **ME** menu, [Edit Detection] is fixed to [On].

Adding Information to Captured Images

Using the Camera Memo

If you register information such as shooting location and work situation in advance, you can add the work site information to the captured image simply by selecting it during shooting. This information is called the “camera memo”.

3

Example of the camera memo

Item Name (Memo Item)	Description (Options)
Client	Company A, Company B, Company C
Construction name	Foundation work, Piping work, Interior finish work
Shooting location	Outdoors, Entrance, Kitchen, Living room
Photographer	(Reading barcode, employee ID card, etc.)

For the images with the camera memo added, you can use the provided software to print the images together with registered information and change the file names to the contents of the camera memo in a batch.

The following procedure explains how to add camera memos during shooting.



Memo

- The camera memo information can be created using the provided software “LE2” on a computer. Transfer the camera memo to the memory card or internal memory in advance. When using a tamper-proof card, transfer the camera memo to the internal memory.
- Up to 100 memo items can be registered in one camera memo list, and up to 999 options can be registered in one memo item.
- For details on the creation of camera memo information and on the provided software, refer to “Operating Manual (for Software)”. (p.94)

Capturing Images with the Camera Memo Added

- 1 Set [Camera Memo] to [On] in the **M5** menu.

Alternatively, press and hold **MEMO** in the shooting mode.

The memo icon appears.



- 2 Press **MEMO**.

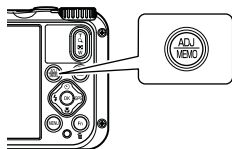

The [Camera Memo] screen appears.

If there are multiple camera memo files, the camera memo used last time is displayed. When using the displayed camera memo, proceed to Step 5.

- 3 Press **Fn**.

The [FILE LIST] screen appears.



- 4 Use **▲▼** to select a file, and press **OK**.

The [Camera Memo] screen reappears.



5 Use ▲▼ to select an item name, and press ►.

The screen to select the camera memo options appears.



Pressing and holding ► on this screen displays the screen to enter the camera memo options.

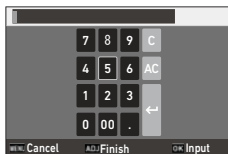

To set the barcode information to the camera memo, select a memo item on the [Camera Memo] screen, and then aim the camera at the barcode and press ◀.



6 Use ▲▼ to select an option.

To temporarily modify the camera memo options, press ►.

In addition to the options set in the camera memo file, the following items can be selected.



Temporary	You can enter information other than the set options with the camera. The barcode data can also be read.
Record	You can record sounds for up to 30 seconds. Press SHUTTER to start recording sounds. Press SHUTTER halfway (or wait for 30 seconds) to end recording.
No Setting	You can add the camera memo without selecting an option. When [Memo Warning] is set in the M6 menu, [No Setting] cannot be selected during shooting.

7 Press **OK**.

The [Camera Memo] screen reappears.
Repeat Steps 5 to 7.

8 Press **OK**.

The camera memo information is set, and the shooting screen reappears.

9 Shoot.

The image is saved with the camera memo added.



Caution

- The camera memo cannot be added if the camera memo file (.mta) is not saved in the memory card or internal memory.
- Items that can be set with the camera memo differ depending on the setting of [Camera Memo Mode] in the **M6** menu. When [Camera Memo Mode] is set to [Mode2], only the combination of options can be selected. You cannot modify the options individually.
- When [Drive Mode] is set to [A-Bracket], the camera memo cannot be added.



Memo

- For details on the camera operation when the camera memo is set, refer to "Camera Memo Settings" (p.125).
- If the file name of an image is specified in the camera memo options and the image is saved in the memory card or internal memory, you can view the image by pressing **MEMO** on the [Camera Memo] screen. The image can be viewed only when [Camera Memo Mode] is set to [Mode2] in the **M6** menu.

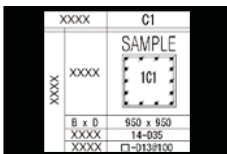

Board

- You can create the board information including construction name, etc. in advance to use it during shooting. The board file can be created using the dedicated software on a computer. Transfer the file to the memory card or internal memory in advance. For the dedicated software, refer to the RICOH website.
- When [Board] is set to [On] in the **M6** menu, the board information is displayed when setting the camera memo. You can check the board list by pressing **Fn** on the [FILE LIST] screen. Pressing **Fn** again displays the board contents.
- You can display the camera memo information on the board and composite it with the captured image. (p.77)

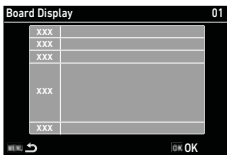

Checking the Camera Memo Added to the Image

1 Display an image in the single image display of playback mode.

The icon appears on the images with the camera memo added.

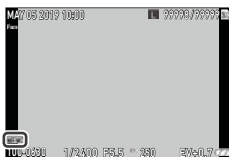

3

Taking Pictures

2 Press **MEMO**.

The [Camera Memo] screen appears.

3 Use **▲▼** to check options.

When reading a barcode, press **◀**.

If you do not want to modify the options, proceed to Step 6.

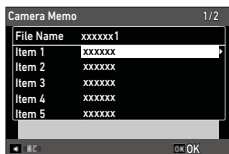

4 Select the item with options to modify, and press **▶**.

The screen to select options appears.

You can select [Temporary] or [Record] in the same way as during shooting.

5 Press **OK**.

The options of the camera memo are changed, and the screen in Step 3 reappears.

6 Press **OK**.

The screen returns to the single image display.

When the options of the camera memo have been changed, the save confirmation screen appears.



Caution

- The camera memo added to images cannot be deleted.



Memo

- You can also switch the camera memo display information by pressing **OK** several times in the single image display. (p.21)

Capturing Images at the Same Angle (Watermark Options)

Images can be captured at the same angle while referring to images captured in the past for the purpose of recording work progress, etc.

- 1** Set the mode dial to **SCN**, and then press **MENU**.
- 2** Select **[Watermark Options]** in the **SCN** menu, and press **Fn**.
The **ME** menu appears.
- 3** Select **[Template]**, and press **▶**.
Images are displayed in the thumbnail view.
- 4** Select a template image, and press **OK**.
Up to 99 images can be selected.
Pressing **OK** again cancels the selection.

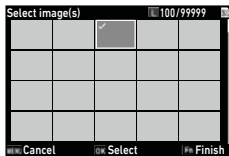

- 5** Press **Fn**.
The selected image is saved as a template.
- 6** Press **MENU**.
The mode switches to the **[Watermark Options]** mode, the template image is displayed semi-transparently.
- 7** Determine the angle according to the template image and shoot.
When multiple template images are selected, you can switch the images with **▶**.
The image is saved with the template image information.



Memo

- Even when the captured mode is changed, if the mode is switched to the [Watermark Options] mode again, the same template image is displayed.
- The selected image is saved even when the camera is turned off.
- The transparency of the template image can be set to [80%], [60%], [40%], or [20%] in [Transparency] of the **ME** menu.
- [Template] and [Transparency] of the **ME** menu are displayed only in the **SCN** mode.

Checking the Image

3

1 Display an image in the single image display of playback mode.

2 Check the image.

Pressing **OK** switches the screen display between “Standard information display”, “Detailed information display”, “No information display”, and the display in which the template image and the captured image are displayed side-by-side.

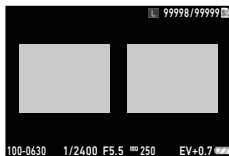

Attaching an Auxiliary Image (Image Clip)

You can capture an auxiliary image (clip image) before capturing the main image and attach it when saving the main image.

1 Select [Image Clip] in the **MF** menu, and press **▶**.

2 Set [Image Clip] to [On].

To end the image clip mode, set it to [Off].

3 Set the recorded pixels of the clip image in [Flag Function Quality].

Select the recorded pixels from [3M], [2M], [1M], and [VGA].

The aspect ratio and quality level is fixed to [4:3] and [☆☆], respectively.

4 Press **MENU** twice.

The image clip icon appears.



5 Press **Fn**.

The [Shoot Clip Images] screen appears.

6 Capture the clip image.

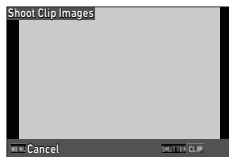

After the clip image is captured, the image clip icon turns yellow.

You can check the captured clip image using **Fn**.

You can take the clip image again by pressing **Fn** again.



7 Capture the main image.

The clip image is attached to the main image, and they are saved as one file.



Caution

- When [Image Clip] is set to [On], the **Fn** functions set in [Fn Setting] of the **C** menu cannot be used.



Memo

- You can also switch the clip image display information by pressing **OK** several times in the single image display. (p.21)

Compositing Images during Shooting

You can composite the small-sized board image or clip image with the captured image.

- 1 Select [Image Composite Sett.] in the **ME** menu, and select a composition method.

Image Composite Sett.	Sets the type of composited images. [Board]: The board image on which the camera memo information is displayed is composited. [Image Clip]: The clip image is composited.
Composite Position	Sets the display position of the composited board and clip image. Select the position from [Upper Left], [Upper Right], [Bottom Left], and [Bottom Right].
Composite Size	Sets the size of the composited board or clip image. Select the size from [Large], [Middle], and [Small].

- 2 Press **MENU** twice.

The image composition icon appears.

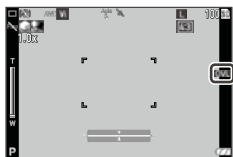

- 3 Capture an image with the method selected in [Image Composite Sett.].

For details, refer to "Capturing Images with the Camera Memo Added" (p.69) or "Attaching an Auxiliary Image (Image Clip)" (p.75).

The image before compositing images and the image composited with the board or clip image are saved respectively.

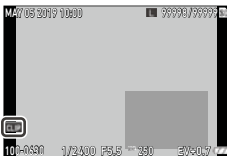

**Memo**

- Images can be composited only when the aspect ratio is set to [4:3].
- When [Grid Guide Display Op.] is set to  in the **C** menu, the position of the composited board or clip image is displayed. (p.109)
- When compositing the board with the captured image, set [Board] to [On] in the **ME** menu and transfer the board file to the memory card or internal memory in advance. For details on the creation of board file and on the provided software, refer to "Operating Manual (for Software)". (p.94)

**Caution**

- Images can be composited only in the following [Drive mode] settings.
 - [Off] (single frame shooting)
 - [Remote Ctl]
 - [Self-timer]

Playback Functions

Changing the Playback Method

Displaying Multiple Images

You can display multiple images in the thumbnail view.

- 1 Press **W** in the single image display of playback mode.
The images are displayed in 20 thumbnails.

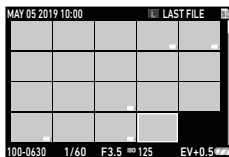

The following operations are available.

▲ ▼ ◀ ▶	Moves the selection frame.
W (W) / Q (T)	Switches between the 20-thumbnail display, the 81-thumbnail display, and the folder (calendar) display.
Fn	Switches between the folder display and the calendar display.
W	Deletes the selected image. (p.83)



- 2 Press **OK**.
The selected image is displayed in the single image display.



Memo

- Images are played back in the order of file numbers automatically assigned to them.

Playing Back Images Continuously (Slideshow)

- 1 Select [Slideshow] in the  menu, and press .

The [Slideshow] screen appears.

- 2 Set the image switching interval and screen effects.

Interval	Sets the image switching interval. [Interval] cannot be set when [Screen Effect] is set to [Random].
Screen Effect	Sets the screen effects applied when images are switched.
Sound Effect	Sets the sound effects. [Sound Effect] is fixed to [Off] when [Screen Effect] is set to [Random].

4

Playback Functions

- 3 Select [Start], and press .



A slideshow starts.

When  is pressed, the slideshow pauses/resumes.

When any other button is pressed, the slideshow stops.

Displaying Rotated Images

You can change image rotation information.

- 1 Display an image in the single image display of playback mode.
- 2 Select [Rotation] in the  menu, and press .
- 3 Select the rotation direction, a press .



Caution

- Rotation direction cannot be changed when the write-protect switch on the memory card is locked or for the following images.
 - Movies
 - Images captured with [M-Cont] or [S-Cont]
 - Protected images



Auto Image Rotation

- When [Auto Image Rotation] is set to [On] in the  menu, the displayed image is rotated according to the camera's orientation during the single image display. When [Auto Image Rotation] is set to [Off] (default setting), the image display orientation is fixed regardless of the [Rotation] setting.
- The following images cannot be rotated.
 - Movies
 - Images captured with [M-Cont] or [S-Cont]
- The images are not rotated in the following cases.
 - During a slideshow
 - While an AV device is connected to the camera

Connecting the Camera to an AV Device

Connect to an AV device, such as TVs, equipped with an HDMI® terminal to display Live View images while shooting or to play back images.

Prepare a commercially available HDMI® cable that is suitable for the device connected to the camera.

1 Turn the AV device and camera off.

2 Open the battery/card cover of the camera, and connect the HDMI® cable to the HDMI® micro output terminal.

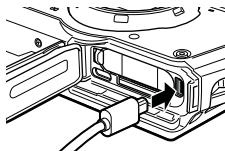

3 Connect the other end of the HDMI® cable to the input terminal on the AV device.

For details, refer to the operating manual for the AV device.

4 Turn the AV device and camera on.

Caution

- When opening and closing the battery/card cover, be sure to remove water and dirt such as sand adhering to the camera, and avoid locations where dirt can enter the camera interior.
- While the camera is connected to an AV device, nothing is displayed on the camera monitor.
- The audio of the movie is output from the AV device. Adjust the volume on the AV device.
- Use an HDMI® cable with a length of 3 m or less (recommended product: RP-CHEU15-K manufactured by Panasonic). The RICOH HDMI cable HC-1 cannot be used.

Memo

- If the camera is connected to an AV device in the playback mode, an image is displayed in the single image display.
- When outputting images to an AV device with an HDMI® terminal, the maximum resolution supported by both the AV device and camera is automatically selected. If the AV device fails to play back images properly, change the setting in [HDMI Out] of the  menu.

Organizing Files

Deleting Files

1 Press  in the single image display or multiple image display.

2 Select the deletion method, and press **OK**.

Available deletion methods vary depending on the camera status when  is pressed.

Single image display	[Delete One], [Delete Multi], or [Delete All] can be selected. When [Delete Multi] is selected, select [Sel. Indiv.] or [Sel. Range].
20-thumbnail display or 81-thumbnail display	[Sel. Indiv.] or [Sel. Range] can be selected.

When [Delete All] is selected, proceed to Step 5.

3 Select the images to delete.

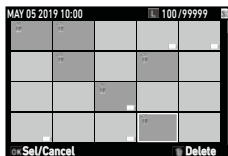

	Moves the selection frame.
OK	Selects/Deselects an image. When [Sel. Range] is selected: Selects the starting or ending point for image selection range.

4 Press .

The confirmation screen appears.

5 Select [Execute], and press **OK**.

The selected images are deleted.

**Caution**

- The following images cannot be deleted.
 - Protected images
 - Images set as [Template] in [Watermark Options] of the **SCN** mode

Restoring Deleted Files

You can restore the deleted files in [Recover File] of the menu.

**Caution**

- The images cannot be restored when the following operations have been performed after deleting them.
 - Turning the camera off
 - Switching from the playback mode to the shooting mode
 - Executing [Image Copy], [Resize], [Cropping], or [Skew Correction] of the menu
 - Executing [Format [Card]] or [Format [Internal M]] of the menu
 - Changing the camera memo in the mode

Copying Images

Images can be copied between the internal memory and the memory card.

1

Insert a memory card.

2

Select [Image Copy] in the menu, and press .

3

Select the copy method, and press **OK**.

[Internal M]>>>[Card]	Copies all images in the internal memory to the memory card. When the memory card space is insufficient, the images cannot be copied.
[Card]>>>[Internal M]	Copies images in the memory card to the internal memory one by one after confirming copying of each file. The file names are automatically changed.

Protecting Images from Deletion

You can protect images to prevent them from being deleted accidentally.

1 Select [Protect] in the **▶** menu, and press **▶**.

2 Select the protection method.

Select the method from [1 File], [Sel. Multiple], [Select All], and [Cancel All].

When [1 File] is selected, use **◀▶** to display the previous/next image.

3 Press **OK**.

When [Sel. Multiple] is selected, proceed to Step 4.

4 Select [Sel. Individ.] or [Sel. Range].

5 Select the images to protect.

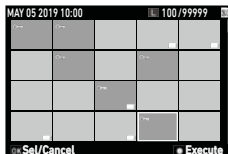

▲▼◀▶	Moves the selection frame.
OK	Selects/Deselects an image. When [Sel. Range] is selected: Selects the starting or ending point for image selection range.

6 Press **Fn**.

The selected images are protected or unprotected.



Memo

- If you apply protection to the images that have already been protected, they are unprotected.



Caution

- If [Format [Card]] or [Format [Internal M]] of the **↶** menu is executed, protected images are also deleted.

Editing and Processing Images

You can edit and process captured images.



Caution



- Only images captured with this camera can be edited and processed. Still images saved from movies cannot be edited and processed.
- If you edit and process images repeatedly, image quality will deteriorate.

Changing the Image Size

4

Changing the Number of Recorded Pixels (Resize)

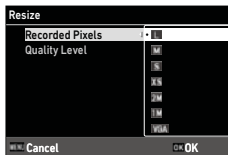

Playback Functions

- 1 Display an image in the single image display of playback mode.
- 2 Select [Resize] in the  menu, and press .
- The [Resize] screen appears.
- 3 Set [Recorded Pixels] and [Quality Level] for the resized image.
The smaller size than the setting for shooting can be selected.
- 4 Press **OK**.
- 5 Select [Overwrite] or [Save as], and press **OK**.
The image is saved.









Cropping Images

You can crop a part of images and then save them.

- 1 Display an image in the single image display of playback mode.
- 2 Select [Cropping] in the  menu, and press .
- 3 Specify the range to crop.



 (T) /  (W)	Changes the cropping size.
   	Moves the cropping frame.

- 4 Press .
The image is saved as a new image.

Processing Images with Filters

You can process images with filters.

1 Display an image in the single image display of playback mode.

2 Select [Filter] in the  menu, and press .



The [Filter] screen appears.





3 Use   to select a filter, and press .

The following filters can be selected.

Small Face Filter	[5%], [7%], [10%]
Ink Rubbing Filter	[1] to [5]
Digital Filter	[Black & White], [Sepia], [Toy Camera], [Retro], [Color], [Extract Color], [Color Emphasis], [High Contrast], [Starburst], [Soft], [Fish-eye], [Miniature], [Brightness]
HDR Filter	—

When [HDR Filter] is selected, proceed to Step 5.

4 Use   to specify a value.

For [Digital Filter], use   to select a filter type, and then use   to specify a value.

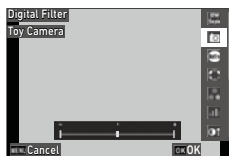



5 Press .

6 Select [Overwrite] or [Save as], and press .

The image is saved.

Editing Movies

- 1 Select [Movie Edit] in the  menu, and press .
The [Movie Edit] screen appears.

- 2 Use   to select an editing method.

Save as Still Image	Saves the specified frame as a still image.
Divide Movies	Divides a movie into two files at the specified division point and saves as new files.
Adding title picture	Specifies the image to be used as the thumbnail for a movie.

For each editing method, refer to the following.

Saving the Specified Frame as a Still Image

- 1 Select [Save as Still Image], and press .
The movie playback screen appears.

- 2 Display the frame to save.

You can play or pause the movie in the same manner as when viewing a movie in the playback mode.

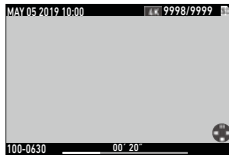

- 3 Press .
The selected frame is saved as a still image.

Dividing a Movie

- 1 Select [Divide Movies], and press **OK**.

The movie playback screen appears.

- 2 Display the frame at which you want to divide the movie.

You can play or pause the movie in the same manner as when viewing a movie in the playback mode.

The dividing point can be specified in 30 frames increments.

- 3 Press **OK**.

The confirmation screen appears.

- 4 Select [Divide], and press **OK**.

The movie is divided at the selected frame and saved as new movie files.



Caution

- The movies with a recording time of less than 2 seconds cannot be divided.

Specifying the Image to Be Used as the Thumbnail for a Movie

- 1 Select [Adding title picture], and press **OK**.

The image selection screen appears.

- 2 Use **◀▶** to select an image.

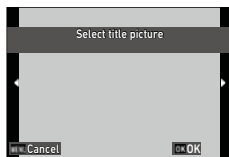

- 3 Press **OK**.

- 4 Specify whether to insert the image at the beginning or at the end of the movie, and press **OK**.

The image is inserted at the beginning or end of the movie.



Memo

- The inserted image is displayed for 3 seconds at the beginning or end of the movie.
- When the image is inserted at the beginning of the movie, it is displayed as the thumbnail for the movie. When the image is inserted at the end of the movie, the thumbnail for the movie is not changed.



Caution

- When the recording time of the movie reaches 26 minutes with the title image inserted, the image cannot be inserted.

Correcting Red Eyes in Images

You can correct red eyes in images captured with a flash.

- 1** Display an image in the single image display of playback mode.
 - 2** Select [Red-eye Edit] in the  menu, and press .
- The image is saved as a new image.



Caution

- The red eyes cannot be corrected for the following images.
 - Images in which the camera cannot detect red eyes
 - Movies

Using Communications and Network

Using a Computer

You can connect the camera to a computer using the provided USB cable.

Setting the Connection Mode

Set the connection mode in [USB Connection] of the  menu according to the operation to be performed with a computer.

MSC (default setting)	The camera is recognized as a device by the computer. Used when copying images from the memory card or internal memory to a computer. (p.93)
MTP	Used when performing shooting by operating the camera from a computer. (p.95)
CD-ROM	Used when installing the PDF or software included in the internal memory of the camera to a computer. (p.94)



Memo

- Refer to "Operating Environment" (p.147) for system requirements to connect the camera to a computer and to use the software.

Copying Images to a Computer

1 Set [USB Connection] to [MSC] in the  menu.

2 Turn the camera off.

3 Open the battery/card cover of the camera, and connect the USB cable to the USB terminal.

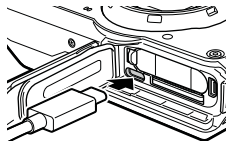

4 Connect the USB cable to the USB port of the computer.

5 Turn the camera on.

The camera is recognized as a device by the computer.

When a memory card is inserted, the files on the memory card are displayed. When a memory card is not inserted, the files in the internal memory are displayed.

6 Copy the captured images to the computer.

7 Disconnect the camera from the computer when the copy is complete.

8 Remove the USB cable from the camera.



Caution

- When opening and closing the battery/card cover, be sure to remove water and dirt such as sand adhering to the camera, and avoid locations where dirt can enter the camera interior.
- Do not remove the USB cable while copying images.



Memo

- You can also import images using the provided software "DL-20".
- You can make settings to request a password when the camera is connected to a computer with the USB cable to prevent unauthorized copying of images, etc. (p.130)

Using the Provided Software

The details of the provided software are described in “Operating Manual (for Software)” included in the internal memory of the camera.

- 1** Set [USB Connection] to [CD-ROM] in the  menu.
- 2** Turn the camera off.
- 3** Connect the camera to the computer with the USB cable.
Refer to “Copying Images to a Computer” (p.93) for how to connect the camera to the computer.
- 4** Turn the camera on.
The installer starts up.
- 5** Click [Browse User’s Manual (Software Version)].
The PDF file of “Operating Manual (for Software)” opens.

Provided Software

The following software is provided with the camera.

DL-20	Used to import images from the camera to a computer.
LE2	Used to create a camera memo list (.mta).
ME2	Used to view images. You can edit the camera memo and print the image and camera memo together on a sheet.
EX2	Used to rename image files according to the options set in the camera memo.
ST-20	Used to make the detailed wireless LAN settings and create a communication list (.PRM). (G900SE only)
SR-20	Used to set up a computer as a server dedicated to the camera. (G900SE only)

For details on how to install and use the software, refer to “Operating Manual (for Software)”.



Caution

- The provided software is compatible with Windows® only. The operating environment of the software is as shown below.
 - Windows® 10 (32-bit, 64-bit)
 - Windows® 8.1 (32-bit, 64-bit)
 - Windows® 7 (32-bit, 64-bit)
 - Windows Server® 2019 (64-bit)
 - Windows Server® 2016 (64-bit)
 - Windows Server® 2012 R2 (64-bit)
 - Windows Server® 2008 R2 (64-bit)

Operating the Camera with a Computer (G900SE Only)

You can operate the camera from a computer using the optional software “IMAGE Transmitter 2”.

1

Set [USB Connection] to [MTP] in the  menu.

2

Turn the camera off.

3

Connect the camera to the computer with the USB cable.

Refer to “Copying Images to a Computer” (p.93) for how to connect the camera to the computer.

4

Turn the camera on.

5

Start “IMAGE Transmitter 2” on the computer.

The IMAGE Transmitter 2 starts up and recognizes the camera.



Memo

- For details on “IMAGE Transmitter 2”, refer to “User Guide [Operation]” available at the following site.
http://www.ricoh-imaging.co.jp/english/support/download_manual.html

Using the Network (G900SE Only)

You can connect the camera with a server or communication device via Bluetooth® or wireless LAN, and transmit and receive data.

Selecting the Communication Method

Select [Wireless LAN], [Bluetooth], or [WLAN/BT] in [Communication Mode] of the  menu according to the communication device connected wirelessly.

The basic operations during wireless connection can be set in the  menu.

Image File Size	Sets whether to resize images when transmitting them. When [Off] is selected, images are transmitted with the original size.
Auto Delete	Deletes images from the camera after they are sent to the communication device.
Transmit Power Off	Transmits images in a batch when the camera is turned off. [Transmit Power Off] is available only during the wireless LAN connection.
Connection Power On	Automatically connects the camera to the previously connected device when it is turned on.

Make settings according to the communication method to be used.

- “Setting the Wireless LAN Connection” (p.98)
- “Setting the Bluetooth® Connection” (p.100)



Caution

- The wireless LAN function is disabled in the following case.
 - While the camera is connected to a device with the USB cable
- Do not attempt to use the Bluetooth® and wireless LAN functions in a location where the use of wireless communication devices is restricted or prohibited, such as on airplanes.
- When using the Bluetooth® and wireless LAN functions, observe local laws and regulations governing radio communication.

Operating the Camera with a Communication Device

The following functions can be used with the communication device wirelessly connected with the camera by using the dedicated application “Image Sync”.

Remote Photography	Displays the shooting screen of the camera on the communication device, and enables making settings and shooting by operating the communication device.
View Images	Displays the images saved in the camera on the communication device and imports them to the communication device.
Synchronize Clock	Synchronizes the date and time displayed on the camera with the date and time settings of the communication device.



Memo

- Image Sync supports iOS and Android™, and can be downloaded from the App Store or Google Play™. For the supported operating system and other details, refer to the download site.
- For how to connect the camera to a communication device and details on the Image Sync, refer to the following website.

<http://www.ricoh-imaging.co.jp/english/products/app/image-sync/>

Shooting with a Communication Device

You can perform shooting remotely with the camera by operating a communication device.

- 1** Set the mode dial to **SCN**, and then press **MENU**.
- 2** Select **[Image Sync]** in the **SCN** menu.
The mode switches to the **[Image Sync]** mode, and the wireless LAN function turns on.
- 3** Start the **Image Sync** on the communication device.
- 4** Turn on the wireless LAN function of the communication device, and connect it to the camera.
Shooting with the **Image Sync** becomes possible.



Memo

- When the camera is turned off or the capture mode is switched, the wireless LAN connection is canceled.
- The camera cannot be operated in the [Image Sync] mode.

Setting the Wireless LAN Connection

Create a list of wireless LAN connection destinations as the “communication list” with the computer, and connect the camera to a server based on this communication list.

When the communication list has already been imported, start the setting procedure from Step 3.

5

Using Communications and Network

- 1 Create the communication list using the provided software “ST-20”, and transfer it to the memory card or internal memory.**
For details, refer to “Operating Manual (for Software)”. (p.94)
When the communication list is transferred to the internal memory, proceed to Step 3.

- 2 Select [Import Com. Setting] in the menu, and press .**
The communication list is imported.
If there is no communication list that can be imported, set the file transmission destination manually in Step 3.

- 3 Select [Send To] in the menu, press , and use to select a file transmission destination.**
You can also check and modify the setting details by pressing .



- 4 Make the [Send Status] settings in the menu.**

On	Displays the communication list when transmitting files. Select a file transmission destination each time.
Off	Transmits files to the file transmission destination selected in [Send To].

5 Make the [Simple Connection] settings in the menu.

Off	Transmits files to the file transmission destination selected in [Send To].
WPS Button	Enables the WPS button connection. If the wireless LAN access point is equipped with a WPS button, you can connect the camera to the access point by simply pressing the button.
WPS PIN	Enables the WPS PIN connection. When the wireless LAN access point supports the PIN method, you can connect the camera to the access point by inputting the PIN code set in the access point.
Scan	Searches connectable wireless LAN access points. You can connect the camera to the access point by selecting the connection destination and entering the network key.
Connection Inf	Displays the information of the connected wireless LAN access point.

6 Select [Wireless LAN] or [WLAN/BT] in [Communication Mode] of the menu.

Setting the Bluetooth® Connection

Make detailed settings in the  menu.

Bluetooth Connection	Select the communication mode from [BLE] (Bluetooth Low Energy) and [Classic].
Bluetooth Serial	Connectable Bluetooth® devices are searched and displayed in a list. Select a connection destination.
Bluetooth Pass Key	You can register a passkey for connection with up to 16 alphanumeric characters. If you register a passkey, authentication is performed automatically when connecting the camera to a Bluetooth® device. Only one passkey can be registered. When connecting the camera to multiple devices simultaneously, set the same passkey in all devices.
Bluetooth Search Ct	You can set the number of Bluetooth® devices to search simultaneously.
Bluetooth Auto Conn	The camera is automatically connected to the previously connected Bluetooth® device when it is turned on.
Bluetooth Mas/Slav	Select [Master] or [Slave].
Bluetooth PF	Select the profile from [OPP], [BIP], and [OPP/BIP].

Connecting External Devices

You can use a barcode reader, GPS device, and range finder equipped with the Bluetooth® function. To use an external device via Bluetooth® connection, make the following settings in the  menu.

Bluetooth Device Sett.	You can select a connection destination device.
Range Finder Mode	You can select the display type of the range finder information. [Mode1]: Always displays the information. [Mode2]: Displays the information until shooting is performed. The information is deleted when shooting is complete. [Mode3]: Performs shooting automatically when the information is received.



Memo

- For the external devices supported by the camera, refer to the following website.
<http://www.ricoh-imaging.co.jp/english/products/>
- When an external GPS device is connected, the GPS function of the camera is disabled.

Transmitting Files

You can transmit the captured images selected to the communication device.

- 1 Select [File Send] in the **▶** menu, and press **▶**.
The [Send To] screen appears.

- 2 Select the file transmission destination.

For the wireless LAN connection, the file transmission destinations imported in [Import Com. Setting] are displayed. (p.98)



The following operations are available.

ADJ	For the Bluetooth® connection: Searches devices again.
▶	Displays detailed information.
⌫	Deletes the file transmission destination.

- 3 Press **OK**.

If a passkey is required for the Bluetooth® connection, enter it within 30 seconds.

- 4 Select [Send One] or [Send All], and press **OK**.

When the camera is in the multiple image display (p.79) before selecting the **▶** menu, select [Sel. Individ.] or [Sel. Range], and press **OK**.











Memo

- Pressing and holding **OK** in the playback mode displays the transmission screen. On this screen, you can select the transmission method as described in Step 4.

Sending an Image Immediately after Shooting

You can send an image while the Instant Review is displayed immediately after shooting. The image is transmitted to the destination previously specified in [File Send] of the  menu.

Set the transmission method in [Quick Send Mode] of  menu.

Off	Does not transmit the image during the Instant Review.
1Touch	Transmits the image when  is pressed during the Instant Review. If  is not pressed within the time set in [Confirm.Time] of the  menu, the image is not transmitted.
2Touch	Transmits the image when  is pressed during the Instant Review displayed by pressing  after shooting. [2Touch] cannot be used when [GPS Lock] is set in the  menu.
AUTO	Transmits the image without displaying the Instant Review. The [Image File Size] setting in the  menu is ignored.

5



Caution

- The image cannot be transmitted during the Instant Review in the following cases.
 - In the **SCN** mode or  mode
 - When [Drive Mode] is set to [Cont. Shoot], [Burst Shoot], [M-Cont], or [S-Cont]



Using the Support Functions

You can use the support functions related to the wireless LAN communication in [Support] of the  menu.

Create Log File	Saves camera operation logs and error logs.
Append CRC	Adds a CRC to the image when transmitting it.
Number of Retries	Sets the number of retries for when the connection to a wireless LAN cannot be established.
AP Connection Timeout	Sets the timeout period for when the connection to a wireless LAN cannot be established.
PING	Transmits a PING entered with the camera keyboard. The response status is displayed on the screen.
Operation Log	Saves the button operation logs in the internal memory.
Retain WLAN Conn.	Retains the wireless connection.

Setting the Camera Operations When Using a Dedicated Server

When a computer is set as the dedicated server (SR-20 server) for the camera with the provided software “SR-20”, you can set the camera operations in [Server Sync.] of the  menu.

Synchronize Clock	You can synchronize the date and time settings of the camera with the ones of the server when the camera is connected to the SR-20 server. [Off]: Does not synchronize the date and time settings. [On]: Synchronizes the date and time settings when the camera is turned on for the first time in a day. [Manual]: Synchronizes the date and time settings when  is pressed.
Update Firmware	When the camera firmware update data is registered in the SR-20 server, you can update the camera firmware. [Off]: Does not update the camera firmware. [On]: Checks whether the latest firmware update data is registered in the server when the camera is turned off for the first time in a day. If the update data is registered in the server, the update execution screen is displayed. [Manual]: Checks whether the latest firmware update data is registered in the server when  is pressed. If the update data is registered in the server, the update execution screen is displayed.

Update Settings	<p>When the camera memo list, communication list, and camera settings file are registered in the SR-20 server, you can update the file in the camera by receiving the files.</p> <p>[Off]: Does not receive the files.</p> <p>[On]: Checks whether the latest files are registered in the server when the camera is turned off for the first time in a day. If the files are registered in the server, the update execution screen is displayed.</p> <p>[Manual]: Checks whether the latest files are registered in the server when  is pressed. If the files are registered in the server, the update execution screen is displayed.</p>
-----------------	--



Memo

- For details on the provided software, refer to "Operating Manual (for Software)". (p.94)
- Before executing the above functions, start the software "SR-20" in the server.

Changing the Settings

Saving Frequently Used Settings

Using the Mode Dial

You can assign frequently used shooting settings to the mode dial **U1** and **U2** so that you can easily recall the settings.

The following settings can be saved.

- Capture mode
- / menu settings (with exceptions)
- A part of **C** menu settings
- A part of **M/E** menu settings

Saving the Settings

- 1 Set the capture mode and all the necessary settings to save.
- 2 Select [Reg. USER] in the **C** menu, and press **▶**.
- 3 Select [U1] or [U2], and press **OK**.
The settings are saved.

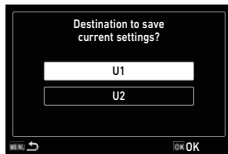

Using the User Mode

- 1 Set the mode dial to **U1** or **U2** in the shooting mode.
- 2 Change the settings as necessary.



Memo

- The settings changed in Step 2 are not saved in the camera. If the mode dial is turned, the settings are reset to the saved settings.

Exporting the Settings to a File

You can export the menu settings to a file and save it in a memory card. The settings can be restored from the exported file. Also, the settings can be copied to multiple cameras using the exported file.

You can export the settings in a memory card using [Write] and can import the settings to the camera using [Read] in [Camera Settings File] of the  menu.



Caution

- The setting file is saved in the "SYSTEM" folder in the memory card with the file name "CAMERA.PRM". When [Write] is executed, the old file is overwritten.
- If the memory card is not available for recording, the setting file cannot be saved.
- If [Camera User Lock Op.] or [Camera Admin. Lock] is set to [Camera] in the  menu, the setting file cannot be loaded. Change the setting to [Off], and then load the setting file.

Customizing the Button Functions

Registering Functions to the ADJ. Button

You can change the settings for “ADJ. mode” of which functions can be easily used by pressing **ADJ.**

Five functions selected from the following functions can be saved. (The functions indicated with a square-bracketed item are the default settings for the item.)

- Off
- EV Comp. [Setting1]
- Recorded Pixels [Setting2]
- Aspect Ratio [Setting3]
- Setting [Setting4]
- White Balance [Setting5]
- Image Tone
- Quality Level
- AE Metering
- AF
- Face Detection
- Highlight Cor.
- Shadow Cor.
- Outdoor View

1 Select [ADJ Button Setting 1] to [ADJ Button Setting 5] in the **C** menu, and press **▶**.

2 Use **▲▼** to select a function, and press **OK**.

The ADJ. mode function is changed.

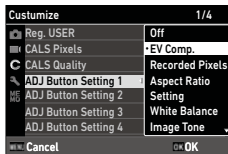

Memo

- Refer to “Using the ADJ. Button” (p.23) for how to use the ADJ. mode.

Registering Functions to the Fn Button

You can register a function in **[Fn]**.
The following functions can be saved.

Still images

- Off
- EV Comp.
- Recorded Pixels
- Quality Level
- Aspect Ratio
- White Balance
- Setting
- AF
- Face Detection
- Auto Macro
- AE Metering
- Highlight Cor.
- Shadow Cor.
- Sharpness
- Saturation/Tone Adjustment
- Contrast
- Outdoor View (default setting)

Movies

- Off
- Movie SR
- Movie SR+
- White Balance
- AF
- Face Detection
- EV Comp.
- Sharpness
- Saturation/Tone Adjustment
- Contrast
- Outdoor View (default setting)

6

Changing the Settings

1 Select **[Fn Setting]** in the **C** menu, and press **▶**.

2 Use **▲▼** to select a function, and press **OK**.

The function is saved.

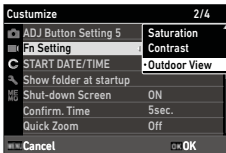

Caution

- The function set to **[Fn]** is enabled in the shooting mode only. Moreover, during shooting with **[Image Clip]** set to **[On]** in the **ME** menu, the function set to **[Fn]** cannot be used.

Display and Sound Settings

Setting the Start-up Screen

The screen display when the camera is turned on can be set in [Start-up Screen] of the **▶** menu.

Start-up screen with operation guide	Displays the capture mode.
RICOH	Displays the RICOH logo.
Photographs	Displays the selected captured image.
Off	Displays nothing.





Setting the Information Displayed when the Camera Is Turned On/Off

You can set the information displayed when the camera is turned on and off in the **C** menu.

START DATE/TIME	Displays the current date and time until the camera is operated after it is turned on.
Show folder at startup	Displays the name of the current folder and the number of images in the folder until the camera is operated after it is turned on.
Shut-down Screen	Displays the RICOH logo and the number of images captured on the day when the camera is turned off.

Setting the Live View Display

You can set the Live View display in the **C** menu.

Grid Guide Display Op.	Select the grid style from  ,  , and  .  is displayed only when [Image Composite Sett.] is set in the ME menu. The size of the composited board or clip image is displayed with a frame. (p.77)
Level Setting	Select the level display from [Off], [Level + Shift], and [Level].



Memo

- The current tilt can be saved as a reference tilt by executing [Calibrate Level] in the **C** menu.

Setting the Brightness of the Monitor

You can adjust the brightness of the monitor in the  menu.

LCD Brightness	Sets the brightness of the monitor.
Outdoor View	Adjusts the brightness of the monitor when the monitor display is difficult to see during outdoor shooting or in other situations.



Caution

- The [LCD Brightness] setting cannot be changed when [Outdoor View] is set.

Setting the Lamp

You can set whether to turn the power button lamp on when the power is turned on in [Power Button Lamp] of the  menu.

6

Setting the Sound Volume

You can set the sound volume in the  menu.

Operation Volume	Sets the sound volume when buttons are operated.
Playback Volume	Sets the sound volume during playback.
Sound	Sets the sound volume for [Startup Sound], [Shutter Sound], [Operation Sound], and [Self-timer Sound].

Power Saving Settings

Automatically Turning the Power Off

The camera turns off automatically if no operations are made for a certain period of time. Set the time until the the camera is turned off in [Auto Power Off] of the  menu.



Memo

- [Auto Power Off] is not available in the following cases.
 - During shooting in the  mode or in [Interval Shooting] of the SCN mode
 - During movie playback or slideshow
 - During data processing
 - While the camera is connected to a computer
 - During FlashAir connection

Dimming the Display



The camera dims or turns off the display automatically if no operations are performed during the set time. The following settings can be set in the  menu.

Power Saving	Dims the display automatically if no operations are performed during the set time to suppress battery drain. Select the time until the display is dimmed from [5sec.], [15sec.], [30sec.], [1min.], and [2min.].
Monitor Auto off Delay	Turns the monitor off automatically if no operations are performed during the set time. Select the time until the the monitor is turned off from [1min.], [5min.], and [30min.].

If the camera is operated, the original brightness and display are restored.



Memo

- [Power Saving] is not available in the following cases.
 - During shooting in the  mode or in [Interval Shooting] of the **SCN** mode
 - In the  mode
 - In the  mode
 - While a menu is displayed
- [Monitor Auto off Delay] is not available in the following cases.
 - During shooting in [Interval Shooting] of the **SCN** mode
 - During movie playback or slideshow
 - While the camera is connected to a computer

Setting the GPS

The camera can acquire information from GPS satellites using the built-in GPS function.



Caution

- Local geographic conditions such as places where radio waves are blocked or reflected may prevent or delay the acquisition of GPS information.
- The positions of GPS satellites are continuously changing and this may prevent or delay the acquisition of GPS information.
- The presence of devices transmitting frequencies close to those of GPS satellites or devices generating a strong magnetic field may interfere with the acquisition of GPS information or deteriorate the GPS information precision.
- Note that the camera may take a while to acquire the GPS information if it has not been used for an extended period or has been moved a great distance from where the GPS information was last acquired.
- The presence of devices generating a strong magnetic field or devices blocking magnetic fields may interfere with the acquisition of correct direction information.
- The GPS function may not work near a broadcast tower, etc. and in a place where strong static electricity is generated.
- The use of GPS, the collection of location information, etc. may be regulated depending on the country and region. When bringing the camera to a foreign country, check with your embassy or travel agency beforehand if there are restrictions on bringing in the camera with the GPS function, logging GPS information, etc.

Displaying the GPS Information

You can record the location information in images using the GPS function. Set in [GPS] of the **C** menu or press and hold **GPS** (**▶**) to turn the GPS function on and off. The GPS information is acquired every one second in the shooting mode.

The acquired GPS information can be checked in "Detailed information display" in the shooting mode (p.20).

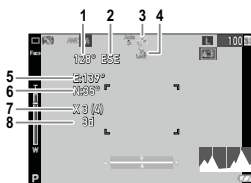

1	Electronic compass information (azimuth)
2	Electronic compass direction
3	GPS positioning status
4	GPS lock
5	Longitude
6	Latitude
7	Number of GPS satellites used (Number of acquired visible GPS satellites)
8	Positioning quality [no fix]: Positioning is not possible. [2d]: The GSA positioning mode in the NMEA-0183 format is "2d". [3d]: The GSA positioning mode in the NMEA-0183 format is "3d". [Diff]: The GGA quality in the NMEA-0183 format is "DGPS".



Memo

- The standard of GPS information displayed on the monitor can be set in [GPS Disp Mode] of the **C** menu.

LAT/LON	Displays the latitude and longitude.
UTM	Displays the Universal Transverse Mercator (UTM) coordinates.
MGRS	Displays the Military Grid Reference System (MGRS) coordinates used as military information.

- The details of the location information recorded in images can be checked in "Detailed information display" in the playback mode (p.20).
- Set [GPS Lock] to [On] in the **C** menu to enable the function to protect the acquired GPS information. The GPS information is protected when **▶** is pressed on the shooting screen. The information is unprotected when **▶** is pressed again.

Automatically Adjusting the Date and Time Settings

The camera date and time settings can be adjusted based on the GPS information by setting [GPS Time Adjustment] to [On] in the **C** menu.

Recording the Camera Route

You can record the camera route using the GPS information.

- Select [GPS Log] in the **C** menu, and press **▶**.
The [GPS Log] screen appears.
- Select [Record log], and press **OK**.



3 Set [Logging Interval] and [Logging Duration].

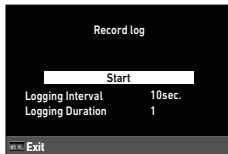

Logging Interval	Select from [1sec.] to [60sec.].
Logging Duration	Select from [1] hour to [24] hours.

4 Select [Start], and press **OK**.

GPS logging starts.

Select [Stop] to stop the GPS logging.

When the set logging time elapses, the GPS logging stops.

6

Caution

- [Interval Shooting] and [Interval Movie] of the **SCN** mode cannot be performed during the GPS logging. If you try to start the shooting, a warning message appears.
- The logging interval may fluctuate in the following cases.
 - When the camera is being turned on or off
 - When the information of a new satellite is being acquired
- The data may be acquired about 1 minute longer than the time set in [Logging Duration].

Saving Logs

You can save the recorded logs to the memory card as a file.

1 Select [Save log data] on the screen in Step 2 on p.115, and press **▶**.

2 Select [NMEA] or [KML], and press **OK**.

The log file is saved in the "GPSLOG" folder in the memory card with the file name composed of the serial number 001 to 999 and the month and day. (Example: 001_0505)

Memo

- You can check the log file by using a software supporting the file on a computer.
- When deleting the log file, select [Discard log data] on the screen in Step 2. The log file cannot be deleted with [Format [Card]] in the **⌘** menu.



Caution

- If the memory card is not available for recording, the log file cannot be saved. Also, a log file cannot be saved in the tamper-proof card.
- When the GPS information has not been acquired, the log file is not saved.

Setting the Direction Information

You can set the direction information displayed on the shooting screen in the **C** menu.

Compass Heading	Sets the displayed information.
Compass Calibration	Executes the adjustment of the compass. Hold the camera with one hand and move it slowly like drawing the figure 8. When the adjustment is completed, a beep sounds.
Declination	Select from [TRUE] and [MAG]. When the GPS information has not been acquired, the information for [TRUE] is not displayed.

Imprinting the GPS Information

The acquired GPS information can be imprinted at the bottom right of the image. Set in [Data Imprint] of the **C** menu.

GPS Data Imprint	Sets the standard of GPS information to imprint.
UTC Data Imprint	Imprints the Universal Coordinated Time. [Date Imprint] of the menu is disabled.
Heading Data Imprint	Imprints the direction information.



Caution

- The imprinted GPS information cannot be deleted.
- The GPS information cannot be imprinted in the following cases.
 - During the shooting in [High Speed Movie] of the **SCN** mode
 - In the mode
 - When [Drive Mode] is set to [Burst Shoot], [M-Cont], or [S-Cont]

File Management Settings

Specifying the Folder/File Settings

By default, folders and files are automatically named as follows.

Folder Name	100RICOH to 999RICOH
File Name	R0000001.JPG to R0999999.JPG

When the file number exceeds R0* *9999, the next folder is created and the file number becomes R0* *0001. If the file number exceeds R0* *9999 when the folder number is 999, no more files can be stored on the memory card currently inserted.

The folder and file names can be changed.

New Folder Options

6

Changing the Settings

When images are captured with this camera, a folder is automatically created and the captured images are stored in it. Each folder name consists of a sequential number from 100 to 999 and a string of 5 characters.

The character string in the folder name can be changed.

1 Select [New folder options] in the  menu, and press **▶**.

2 Use **▲▼** to select a setting.

Standard	100RICOH to 999RICOH
Date	Assigns four digits of the month and day of the shooting date after the folder number. The month and day appear according to the date format set in [Date Adjustment] of the  menu. Example) 101_0125: Images captured on January 25th
Custom	Assigns a freely defined string of five characters after the folder number. (Default: RICOH) Example) 101RICOH

When [Standard] or [Date] is selected, proceed to Step 6.

3 Select [Custom], and press **▶**.

The text-entry screen appears.

4 Enter a folder name.

Up to five single-byte alphanumeric characters can be entered.

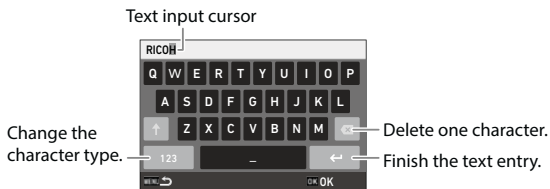

	Moves the text selection cursor (yellow frame).
	Enters a character selected with the text selection cursor.

5 After entering the text, move the text selection cursor to , and press .

6 Select [Execute], and press .





- Memo**
- A folder with a new number is created when the next shooting is performed after the folder name is changed.
 - The images stored in the folder created with the setting [Standard] can be imported to a computer using the provided software "DL-20". (p.94)



- Caution**
- The maximum folder number is 999. If the folder name is changed after the folder number reaches 999, you cannot capture new images. Also, you cannot capture new images when the file name number reaches 9999.
 - For the maximum folder number and maximum file number of the tamper-proof card, contact the card manufacturer.

File Name



The character string "R001" is used as the file name prefix by default. You can change this character string.

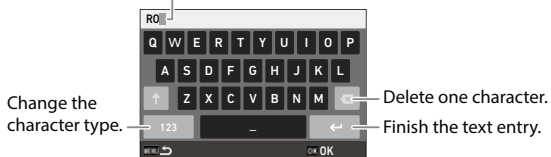

- 1 Select [File name] in the  menu, and press .
- 2 Select [Custom], and press .
- 3 Select a character to enter.

Uppercase alphanumeric characters and "-" can be entered.

Text input cursor



	Moves the text selection cursor (yellow frame).
	Enters a character selected with the text selection cursor.

- 4 After entering the text, move the text selection cursor to , and press .



Caution

- For the images captured while [File name] is set to [Custom], the file name is changed to "RIMG****.JPG" when they are imported to a computer using the provided software "DL-20".

File Sequence No.

In [File Sequence No.] of the  menu, you can set whether to continue the sequential numbering for file names even when memory cards are replaced.

On	Continues the sequential numbering for file names even after memory cards are replaced.
Off	Resets the numbering for file names after memory cards are replaced.

Reset File Number

If [Reset File Number] of the  menu is executed, a folder with a new number is created and file number starts from 0001.



Memo

- When a memory card is not inserted, the file number in the internal memory is reset.
- When the file number reaches the limit, a new folder is created and the file number is reset automatically. The file number limit differs depending on the [File Sequence No.] setting in the  menu, as shown below.

File Sequence No.	File Number Limit
On	9999999
Off	9999

Setting the Copyright Information

You can set the copyright information embedded in the Exif data.

1 Select [Embed Info] in the  menu, and press .

2 Select [On] or [Off], and press **OK**.

3 Select [Copyright Info], and press .
The text-entry screen appears.

4 Enter the copyright holder.

Up to 32 single-byte alphanumeric characters and symbols can be entered.

Text input cursor

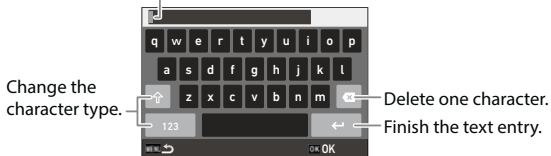

	Moves the text selection cursor (yellow frame).
OK	Enters a character selected with the text selection cursor.

5 After entering the text, move the text selection cursor to , and press **OK**.

The  menu reappears.

The first 11 characters of the entered copyright holder are displayed.



Memo

- You can check the copyright information in "Detailed information display" in the playback mode (p.20).



Imprinting the Copyright Information

The copyright information can be imprinted at the bottom of the image. Set in the  menu.

Copyright Print	Select from [On(OVR)], [On(New)], and [Off].
Copyright Position	Select from [Left], [Middle], and [Right].
Copyright Font Size	Select from [Large], [Middle], and [Small].
Copyright Color	Select from [Orange], [White], [Black], [Red], [Blue], [Green], and [Yellow].



Caution

- The imprinted copyright information cannot be deleted.
- The copyright information cannot be imprinted in the following cases.
 - During the shooting in [High Speed Movie] of the **SCN** mode
 - In the  mode
 - When [Drive Mode] is set to [Burst Shoot], [M-Cont], or [S-Cont]
 - When [Copyright Info] is not set in the  menu
 - When [Image Composite Sett.] is set to [Board] or [Image Clip] in the **ME** menu and [Copyright Print] is set to [On(New)]
- When [Copyright Font Size] is set to [Large] or [Middle], a part of the copyright information may not be imprinted.

Saving the Local Date and Time of the Specified City

The date and time set in “Initial Settings” (p.39) serve as the date and time of your present location and are reflected in the shooting date and time for images.

Setting the destination to a location other than your present location enables you to save images time-stamped with the local date and time.

- 1 Select [World Time] in the  menu, and press .

The [World Time] screen appears.

- 2 Select [Destination] in [Select Time].

Select [Hometown] to reset the date and time to the ones of your present location.

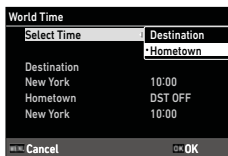

- 3 Press  at [Destination], and set the daylight saving time.

If the daylight saving time is applied to the city to set, turn [DST] on.

- 4 Press  at the city name row, and select the destination city.

The destination city can be selected from 75 cities.

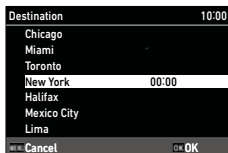

- 5 Press .

Memo

- Even if [Reset] of the  menu is executed, the [Hometown] and [Destination] settings are not reset.

Camera Memo Settings



Setting the Camera Memo Mode

The setting method of the camera memo can be set in [Camera Memo Mode] of the **M6** menu.

Mode1	You can select a [Description] option for each [Item name] of the camera memo. The image cannot be viewed even when it is registered in [Description].
Mode2	You can select a pair of [Description] options with ◀▶. The first and second [Description] options entered in [Item name], the third and fourth options, and so on are treated as pairs. You cannot use a temporary memo and modify the memo options during shooting or playback.
Mode3	You can select a [Description] option for each [Item name]. [Description] options that can be selected are different for each [Item name]. For example, you can use this mode to select a country for the first memo item, and a corresponding prefecture for the second memo item.
Mode4	You can set the camera memo in the format advocated by the Japanese Council for the Sophistication of Digital Construction Site Photography. [Edit Detection] is fixed to [On] in the M6 menu.

Operations when setting the camera memo can be set with the following setting items.

Memo Skip	Sets the memo item to be fast-forwarded when [Camera Memo Mode] is set to [Mode2] and ◀▶ is pressed and held.
Mark Memo Added	Displays the [Memo Marking] indication on the camera memo for the captured images when [Camera Memo Mode] is set to [Mode2].
Remove Memo Marking	Deletes the [Memo Marking] indication on the camera memo screen.
Memo Warning	Displays a warning when an option of the camera memo is in the [No Setting] state. [Memo Warning] is disabled when [Camera Memo Mode] is set to [Mode2] and when [Memo 1 Auto Delete] is set to [On].
Memo at Startup	Displays the [Camera Memo] screen when the camera is turned on or when the capture mode is switched.
Memo Increment	Enables to increase and decrease the number entered at the end of a camera memo option using ▲▼. [Memo Increment] is disabled when [Camera Memo Mode] is set to [Mode2].

Camera Memo Imprint	Imprints the selected options of the first three memo items on the image. Up to 10 characters are imprinted as the memo item name. Up to 42 characters (30 characters when [Recorded Pixels] is set to [VGA] in the  menu) including the characters set for the memo item name are imprinted as the option. [Camera Memo Imprint] is disabled when [Barcode Mode] is set to [Mode3].
Memo 1 Auto Delete	Resets the first memo item to [No Setting] every time after shooting to prevent from forgetting to set the memo item during shooting. [Memo 1 Auto Delete] is disabled when [Camera Memo Mode] is set to [Mode2].
Memo Overwrite	Overwrites the options in the camera memo file with the options entered on the playback screen.
10 Keyboard	Displays the numeric keypad screen when  is pressed on the camera memo to enter measured values, etc.

Using a Barcode

6

Changing the Settings

When setting the temporary memo with barcodes captured with the camera, the registration method of read barcode data can be set in [Barcode Mode] of the  menu.

Mode1	You can register the barcode data in the first memo item. Each time the barcode is read, the data is overwritten.
Mode2	You can register the barcode data in the first to fourth memo items.
Mode3	You can register the data of up to 50 barcodes in the first memo item. You cannot edit the read barcode data. After shooting, the barcode data is deleted.
Mode4	You can register the barcode read the first time in the first memo item and the barcode read the second time in the second memo item. The barcodes read subsequently are overwritten in the first memo item. The data is retained until the camera is turned off.
Mode5	You can register the barcode read the first time in the first memo item and the barcode read the second time in the second memo item. The barcodes read subsequently are overwritten in the second memo item. The data is retained until the camera is turned off.

Mode6	<p>You can read and register the QR code converted from the camera memo options entered as shown below. Use a commercially available application, etc. to create QR codes.</p> <div style="text-align: center;"> <pre> Item order Space /***1 xxxxxx Item name (memo item) Description (option) Line break (CRLF code) Line break (CRLF code) </pre> </div>
Mode7	You can enter the barcode data in the selected memo item.
Mode8	<p>You can enter the barcode data of up to 10 memo items automatically and consecutively according to the input definition.</p> <p>Define the item order by separating memo item numbers with commas (.). The barcode data are entered according to this defined item order. Up to 10 memo items can be specified.</p> <p>For example, when the item order is defined as "3, 1, 2", the data of memo item 3, memo item 1, and memo item 2 are entered in order.</p>

Barcode details can be set with the following setting items.

Barcode Type	<p>Sets the type of barcode to read.</p> <p>[AUTO]: The type is determined automatically.</p> <p>[1D Barcode]: EAN-13/8 (JAN-13/8), UPC-A/E, UPC, EAN (with add-on), Interleaved 2 of 5, CODEBAR (NW-7), CODE39, CODE93, CODE128 TYPE-C, GS1-128 (EAN-128), RSS (GS1 DataBar)</p> <p>[QR Code], [Micro QR], [DataMatrix], [PDF417], [Micro PDF417], [MaxiCode], [EAN.UCC], [Aztec]: 2D barcode</p> <p>Up to 32 digits can be read for 1D barcodes. Up to 2400 digits can be read for 2D barcodes. Voice memo cannot be used with 2D barcodes.</p>
Scan Time	Sets the time to read the barcode.
Barcode LED	Turns on the ring light when reading the barcode.

Using an IC Card (G900SE Only)

You can enter information such as photographer name in the camera memo using NFC-compatible IC cards.

Set [NFC] to [On] in the  menu, and make settings in [NFC Setting].

Security	Sets the IC card ID as the password. (p.129)
DB Co-op	Uses the user list including the IC card IDs and the user's names and affiliations. Create the user list with the provided software "ST-20" on a computer and transfer it to the camera in advance.

When entering information using an IC card, touch the IC card on the NFC mark on the top of the camera.



Caution

- After setting [NFC] to [On] and registering an IC card, you cannot change the [NFC] setting to [Off]. The [Security] setting in [NFC Setting] cannot also be changed to [Off].

Security Settings

Setting a Password on the Camera

You can set passwords for the administrator and user of the camera, respectively, to restrict available functions.

- 1 Select [Set/Edit User PW] or [Set/Edit Admin. PW] in the **ME** menu.

When changing the password, enter the old password.

- 2 Select the password input method.



Keyboard	Uses the keyboard displayed on the camera to enter up to 16 characters. Refer to p.118 for how to enter characters.
Barcode	Enters the password by reading the barcode with the camera. 1D barcode and 2D barcode can be read.
NFC (G900SE only)	Enters the password by touching an NFC-compatible IC card. Make [NFC] and [NFC Setting] settings in ME menu in advance. (p.128)

- 3 Enter the password.

- 4 Re-enter the password entered in Step 3.

If the two passwords match, the password is set on the camera.



Caution

- Be careful not to forget the password you set. If you have forgotten your password, contact your service center.



Memo

- When [NFC] is selected, up to 10 user passwords can be registered. If you try to delete a password, all passwords are deleted together at one time.
- When changing the password, enter the old password, and then enter the new password. If you finish the password setting without entering the new password, the setting is canceled.

Restricting Available Functions

You can set the range of available functions for users and administrators. Setting the operation requesting a password prevents users who do not know the password from using functions.

- 1 Select [Camera User Lock Op.] or [Camera Admin. Lock] in the **ME** menu.
- 2 Enter the password.
Enter the password set in [Set/Edit User PW] or [Set/Edit Admin. PW].
- 3 Select an operation requesting a password with **▲▼**, and press **▶**.
Multiple operations can be set in combination.

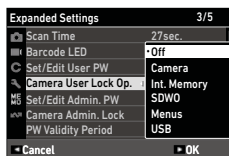

6

Changing the Settings

Off	Does not request a password.
Camera	Requests a password when turning the camera on.
Int. Memory	Requests a password when trying to play back images in the internal memory or when connecting the camera to a computer with a USB cable. If a memory card is inserted, a password is requested when the camera is turned on.
SDWO (G900SE only)	Requests a password when accessing an inserted tamper-proof card.
Menus	Requests a password when MENU is pressed or when switching the mode to the ADJ. mode.
USB	Requests a password when connecting the camera to a computer with a USB cable.
WEB (G900SE only)	Requests a password when setting the camera to the [Image Sync] mode while it is connected to a communication device via Bluetooth® or wireless LAN.

- 4 Press **◀**.
- 5 Select [Execute], and press **OK**.



Caution

- The administrator password is required to cancel the function restriction set with either [Camera User Lock Op.] or [Camera Admin. Lock]. When the administrator password has not been set, use the user password to cancel [Camera User Lock Op.].

Setting a Password on the Memory Card

You can set a password on the memory card.

When the memory card with a password set is inserted to the camera, and the camera is turned on, the password is requested.

1

Insert a memory card to set the password, and select [Set/Edit SD Card PW] in the **M6** menu.

2

Select [Execute], and press **OK**.

3

Enter the password.

Refer to “Setting a Password on the Camera” (p.129) for how to display the menu.

4

Re-enter the password entered in Step 3.

If the two passwords match, the password is set on the camera.



Caution

- For the memory cards with which proper operation has been confirmed, refer to the RICOH website.
- The memory card with a password set cannot be read into a computer using a card reader, etc. Connect the camera to a computer with a USB cable to read the card. (p.93)
- The password is not deleted even when [Format [Card]] is executed in the **M6** menu.
- Be careful not to forget the password you set. The password cannot be reset at the service center.

Setting the Password Validity Period

You can set the period for which restriction of functions is canceled after a correct password is entered with [PW Validity Period] and [Card PW Unlock Time] of the **MF** menu.

When [PW Validity Period] or [Card PW Unlock Time] is set to [Off], the password is requested every time.

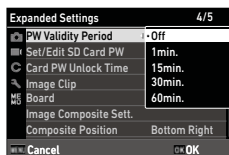

Memo

- [PW Validity Period] is the password validity period when [Camera User Lock Op.] or [Camera Admin. Lock] is set to [Camera] or [Int. Memory].

Attaching Optional Accessories

Wide Conversion Lens

If the wide conversion lens (DW-5) is attached to the camera, you can perform shooting with the 0.8x lens magnification (35 mm equivalent focal length: 22 mm (wide angle)).

When using the wide conversion lens, set [Lens Adapter On] to [WIDE] in the **C** menu. Refer to the User's Manual provided with the wide conversion lens for details.



Memo

- A commercially available 37 mm diameter filter can be attached to the lens. This filter is effective to protect the camera from scratches and condensation.
- When [Lens Adapter On] is set to [WIDE] in the **C** menu, this setting information is recorded in the Exif data.



Caution

- When [Lens Adapter On] is set to [WIDE] in the **C** menu, the functions that can be set are restricted.

AC Adapter

If you intend to charge the camera faster, the use of the AC adapter (K-AC166) is recommended.

1 Make sure that the camera is turned off, and open the battery/card cover.

2 Connect the USB cable (Type-C) of the AC adapter to the USB terminal of the camera.

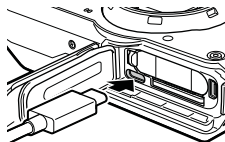

3 Connect the AC plug cord to the AC adapter, and plug the cord into the power outlet.

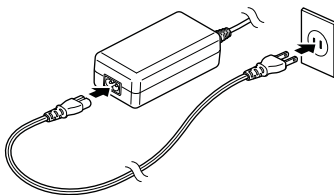

7

Appendix



Caution



- When opening and closing the battery/card cover, be sure to remove water and dirt such as sand adhering to the camera, and avoid locations where dirt can enter the camera interior.
- Securely connect the power plug and AC plug cord.
- When the camera is not used, unplug the AC adapter from the power outlet and disconnect it from the camera.
- Do not move the camera by holding the AC adapter cable while the AC adapter is used.
- The AC adapter may not be usable depending on the country and region.



Troubleshooting

Power Supply

Problem	Cause	Solution	Page
The camera does not turn on.	The battery is not inserted.	Charge the battery and correctly insert it into the camera.	p.37
	The battery is exhausted.		
	The battery is not inserted in the correct orientation.		
	The battery is incompatible.	Use the battery DB-110 exclusively developed for this camera.	—
The camera turns off during use.	The [Auto Power Off] function has been activated because the camera was not operated for a certain period of time.	Turn the camera back on.	p.39
	The battery is exhausted.	Charge the battery.	p.37
The camera does not turn off.	The camera is malfunctioning.	Take the battery out and insert it again.	p.34
The low battery indicator is displayed or the camera turns off even when a fully charged battery is installed.	The battery is incompatible.	Use the battery DB-110 exclusively developed for this camera.	—
The battery cannot be charged.	The battery has reached the end of its service life.	Replace the battery with a new one.	—
	The battery is hot.	Let the battery cool down to ambient temperature.	—
The battery is quickly exhausted.	Ambient temperature is very high or very low.	—	—



Shooting

Problem	Cause	Solution	Page
Shooting cannot be performed by pressing SHUTTER .	The battery is exhausted.	Charge the battery.	p.37
	The camera is turned off or not in the shooting mode.	Turn the camera on or press SHUTTER to switch the camera to the shooting mode.	p.39
	The memory card is not formatted.	Perform [Format [Card]] of the  menu.	p.40
	The memory card is full.	Insert a new card, or delete unwanted files.	p.83
	The memory card has reached end of its service life.	Insert a new memory card.	—
	The memory card is locked.	Unlock the card.	—
	The memory card contacts are dirty.	Clean with soft, dry cloth.	—
Images cannot be checked after shooting.	Confirmation time is too short.	Change the setting of [Confirm. Time] in the C menu.	p.42
The monitor is blank.	The monitor brightness is dark.	Adjust the brightness of the monitor in the  menu.	p.110
	The monitor is off.	Press OK to turn the monitor on.	p.20
	An AV device is connected to the camera.	Remove the cable from the camera.	p.82
The camera is unable to focus in autofocus mode.	The lens is dirty.	Clean with soft, dry cloth.	—
	The subject is not at center of frame.	Lock the focus for shooting.	—
	The subject is not suitable for autofocus.	Lock the focus or set the focus mode to [MF] for shooting.	p.51
	The subject is too close.	Use [Macro] for shooting or move away from the subject.	p.49
Images are blurred.	The camera was moved when SHUTTER is pressed.	Hold the camera with your elbows pressed against your body, or use a tripod.	—
	When shooting in a dark place, captured images become easily blurred.	Use a flash, or set [Setting] to a high ISO sensitivity.	p.54 p.52
The flash does not discharge. The flash is not charged.	A function preventing flash operation is selected.	Check the settings and mode.	—
	The battery is exhausted.	Charge the battery.	p.37



Problem	Cause	Solution	Page
Images are too bright.	Flash output is not appropriate.	Move away from the subject or use a different light source.	—
	The monitor brightness is not appropriate.	Adjust the brightness of the monitor in the  menu.	p.110
Images are too dark.	The monitor brightness is not appropriate.	Adjust the brightness of the monitor in the  menu.	p.110
	The exposure compensation is set to a negative value.	Change the exposure compensation value.	p.46
The colors of images are unnatural.	The camera is unable to adjust white balance for shooting conditions using auto white balance.	Include a white object with the subject or select the settings other than [Auto WB] for [White Balance].	p.56
The monitor brightness changes during autofocus.	Ambient lighting is poor or differs from that used for autofocus.	This is normal and does not indicate a malfunction.	—
Electronic level indicators are not displayed.	Electronic level indicators are hidden.	Check the setting of [Level Setting] in the  menu.	p.109
The image is not level although level indicator showed that the camera was level.	The camera was moving during shooting because you were on a moving object or due to other causes.	Do not move the camera during shooting.	—
	The subject is not level.	Check the subject.	—

Playback/Deletion

Problem	Cause	Solution	Page
Shooting information is not displayed.	Information display is set to "No information display".	Press  to switch the information displayed on the screen.	p.20
Images cannot be played back. Images are not displayed on the monitor.	The AV device is not correctly connected with the camera.	Connect the cable correctly.	p.82
Images are not displayed on an AV device.	The cable is not correctly connected.	Connect the cable correctly.	p.82
	The input setting of the AV device is incorrect.	Check the AV device settings.	—

Problem	Cause	Solution	Page
The images on the memory card cannot be played back. Images are not displayed on the monitor.	The inserted memory card is not formatted with this camera.	Insert a memory card formatted with [Format [Card]] of the  menu in this camera.	p.40
	The memory card contacts are dirty.	Clean with soft, dry cloth.	—
	The card is malfunctioning.	There is not problem with the camera if images in another memory card can be played back with this camera. Do not use a memory card that has a problem.	—
The monitor turned off.	The battery is exhausted.	Charge the battery.	p.37
	The [Auto Power Off] function has been activated because the camera was not operated for a certain period of time.	Turn the camera back on.	p.39
File(s) cannot be deleted.	[Protect] is set for the image(s).	Cancel the protection with [Protect] of the  menu.	p.85
	The memory card is locked.	Unlock the card.	—
	A tamper-proof card is used.	The images saved in the tamper-proof card cannot be deleted.	p.36
The memory card cannot be formatted.	The memory card is locked.	Unlock the card.	—

Others

Problem	Cause	Solution	Page
The memory card cannot be inserted.	The card is not in the correct orientation.	Insert the memory card in the correct orientation.	p.34
Camera controls have no effect.	The battery is exhausted.	Charge the battery.	p.37
	The camera is malfunctioning.	Turn the camera back on.	p.39
		Take the battery out and insert it again.	p.34
Date is not set correctly.	Date and time are not set correctly.	Set date and time correctly in the  menu.	p.40
The date setting has been reset.	The battery was removed.	If the battery is removed for more than about five days, the date setting will be lost. Set date and time correctly in the  menu.	p.40

Error Messages

Error Message	Description
Insufficient Memory	The memory is full and no more files can be saved. Insert a new memory card or delete unwanted files. (p.83)
No image	There are no files that can be played back.
Unmatched File	You are trying to play back a file in a format not supported by this camera. You may be able to play it back on a computer.
Memory card error	The memory card has a problem, and shooting and playback are impossible. You may be able to play it back on a computer.
Format card.	The memory card you have inserted is unformatted or has been previously used on another device. Use the card after formatting it with this camera. (p.40)
Card is locked	The write-protect switch on the memory card you have inserted is locked.
Card Error	A memory card not compatible with this camera is inserted.
Set date.	The date and time are not set. Set the date and time. (p.40)
Insufficient memory. Continue?	Some files cannot be copied with [Image Copy] of the  menu because the memory card space is insufficient. Use another memory card or delete unwanted files.
The file selected for deletion is protected.	You are trying to delete a protected file. Cancel the protection. (p.85)
Format internal memory.	Format the internal memory. (p.40)

Main Specifications

Camera

Lens		RICOH lens, 11 elements in 9 groups (5 aspherical lens elements)
	Focal Length	5 to 25 mm
	35 mm Equivalent Focal Length	Approx. 28 to 140 mm
	Maximum Aperture	F3.5 (W) to F5.5 (T)
Zoom Magnification	Optical Zoom	5x
	Digital Zoom	Approx. 8.1x
	Intelligent Zoom	10M: Approx. 7x 640: Approx. 40.5x (zoom magnification obtained together with the optical zoom)
Motion Blur Reduction	Still Image	Pixel Track SR High-sensitivity shake reduction mode (Digital SR)
	Movie	Movie shake reduction mode (Movie SR, Movie SR+)
Focus	Type	9-point AF, Spot AF, Auto tracking AF
	Focus Range (from lens face)	Standard: 0.5 m (1.64 ft) to ∞ (entire zoom range) Macro: 0.1 to 0.6 m (0.33 to 1.97 ft) (entire zoom range) 1cm Macro: 0.01 to 0.3 m (0.03 to 0.98 ft) (intermediate portion of the zoom range) Switchable to Infinity-landscape, Pan Focus, Manual Focus, and 2.5 m. • 2.5 m is available only in [Firefighting] of the SCN mode.
Effective Pixels		Approx. 20 megapixels
Image Sensor		1/2.3" CMOS
Recorded Pixels	Still Image	Size: L (20M), M (10M), S (5M), XS (3M), 2M, 1M, VGA • When the aspect ratio is set to 4:3, the sizes in parentheses are used. • 2M and 1M are available only in the CALS mode. Aspect ratio: 4:3, 3:2, 1:1 • In the CALS mode, the aspect ratio is fixed to 4:3.
	Movie	4K, 1920, 1280
Sensitivity (standard output)		Auto, Manual (ISO 125 to 25600)
White Balance		Auto, Daylight, Shade, Cloudy, Tungsten, Fluorescent (D: Daylight color, N: Daylight white, W: Cool white, L: Warm white), Ring Light, Manual
Monitor	Type	3.0" Wide LCD, Approx. 1040 K dots, With AR coating (cover only)
	Adjustment	Brightness, Outdoor view setting: ±2 steps

Exposure Control	Metering System	Multi-segment metering, Center-weighted metering, Spot metering
	Exposure Compensation	±2 EV (1/3 EV steps)
Capture Mode		Auto Picture, Program, HDR, Movie, High Speed Movie, Digital Microscope, Interval Shooting, Interval Movie, Surf & Snow, Digital SR, CALS , Watermark Options, Firefighting, Skew Correction, Text Mode, Zoom Macro, Remove Haze, DOF Composite
Face Detection		Maximum detectable faces: 30 Smile capture, Self-portrait assist, Self-portrait assist + Smile capture, Blink detection
Playback Mode		Slideshow, Rotation, Small Face Filter, Ink Rubbing Filter, Digital Filter (B&W/Sepia, Toy Camera, Retro, Color, Extract Color, Color Emphasis, High Contrast, Starburst, Soft, Fish-eye, Brightness, Miniature), HDR Filter, Movie Edit, Red-eye Edit, Resize, Cropping, Image Copy, Protect, Start-up Screen, Recover File, Auto Image Rotation, Skew Correction
Shutter Speed		1/4000 to 1/4 seconds (with the mechanical shutter and electronic shutter used together) Up to 4 seconds
Built-in Flash	Mode	Auto flash, Flash off, Flash on, Auto flash + Red-eye edit, Flash on + Red-eye edit
	Flash Effective Range	Wide angle: Approx. 0.2 to 5.5 m (0.66 to 18 ft) (when the ISO sensitivity is set to Auto) Telephoto: Approx. 0.2 to 3.5 m (0.66 to 11 ft) (when the ISO sensitivity is set to Auto)
Drive Mode		Single-frame shooting, Self-timer, Continuous shooting, Burst shooting, M-continuous shooting, S-continuous shooting, Remote control, Auto bracketing
Storage Media		Internal memory (approx. 6.5 GB) SD/SDHC/SDXC memory card FlashAir card
Power Supply		Rechargeable battery DB-110, AC adapter kit K-AC166 (optional), Battery charger BJ-11
	Battery Life	Still image shooting: Approx. 340 images (with the rechargeable battery) ¹ <ul style="list-style-type: none"> Tested in compliance with CIPA standard using a fully charged lithium-ion battery at a temperature of 23°C (73°F). Actual results may vary depending on the shooting conditions/circumstances. Movie playback: Approx. 260 minutes (with the rechargeable battery) ²
Interfaces		USB 3.0 (Type C), HDMI output terminal (Type D)
Waterproof and Dustproof Rating		JIS/IEC waterproof class 8, JIS/IEC dustproof class 6

Dimensions	Approx. 118.2 mm (W) × 65.5 mm (H) × 33.1 mm (D) (4.7 in. (W) × 2.6 in. (H) × 1.3 in. (D)) (excluding operating controls and protrusions)
Weight	Approx. 252 g (8.9 oz) (including the dedicated battery and SD memory card) Approx. 225 g (7.9 oz) (body only)
Included Accessories	Rechargeable battery DB-110, Battery charger BJ-11, USB power adapter, Power plug, USB cable, Neck strap, Macro stand
Language	English, French, German, Spanish, Portuguese, Italian, Dutch, Japanese, Danish, Swedish, Finnish, Polish, Czech, Hungarian, Turkish, Greek, Russian, Thai, Korean, Simplified Chinese, Traditional Chinese
GPS	GPS, GLONASS, QZSS (Michibiki) + SBAS GPS display mode: LAT/LON, UTM, MGRS GPS lock, GPS time adjustment, GPS logging, GPS data imprint, UTC data imprint
Electronic Compass	Compass display: Cardinal direction, Degrees, Cardinal direction + Degrees Declination correction, Heading data imprint

*1 Image storage capacity shows approximate number of images stored during CIPA-compliant testing. Actual results may vary depending on the shooting conditions/circumstances. (Excerpt from CIPA standard: With the monitor ON, with 50% use of flash, at 23°C (73°F))

*2 According to the result of RICOH in-house testing.

Wireless LAN Communication (G900SE Only)

Standard	IEEE 802.11a/b/g/n/ac (standard wireless LAN protocol)
Frequency (Center Frequency)	2.4 GHz (channels: Ch 1 to Ch 11), 5 GHz (channels: Ch 36 to Ch 48) • Fixed to 2.4 GHz in the AP mode
Security	WEP (64/128 bit), WPA/WPA2-mixed PSK, WPA/WPA2-mixed EAP supporting "Enterprise" mode EAP-TLS, PEAP (MS-CHAP v2)

Bluetooth® Communication (G900SE Only)

Standard	Bluetooth® v4.2 BLE (Bluetooth Low Energy)
Frequency (Center Frequency)	2.4 GHz (channels: Ch 0 to Ch 39)

NFC Communication (G900SE Only)

Standard	FeliCa, MIFARE®, ISO/IEC 14443 Type A/B
Frequency (Center Frequency)	13.56 MHz

USB Power Adapter AC-U1/AC-U2

Power Supply	100 to 240 VAC (50/60 Hz), 0.2 A
Output	5.0 VDC, 1000 mA
Operating Temperature	10 to 40°C (50 to 104°F)
Dimensions	42.5 mm (W) × 22 mm (H) × 66.5 mm (D) (1.7 in. (W) × 0.9 in. (H) × 2.6 in. (D)) (excluding the power plug)
Weight	Approx. 40 g (1.4 oz) (excluding the power plug)

Rechargeable Battery DB-110

Nominal Voltage	3.6 V
Rated Capacity	1350 mAh, 4.9 Wh
Operating Temperature	0 to 40°C (32 to 104°F)
Storage Temperature	-10 to 45°C (14 to 113°F)
Dimensions	39.8 mm (W) × 34.2 mm (H) × 8.5 mm (D) (1.6 in. (W) × 1.3 in. (H) × 0.3 in. (D))
Weight	Approx. 26 g (0.9 oz)

Battery Charger BJ-11

Rated Input	5 VDC, 1 A
Rated Output	4.2 VDC, 900 mA
Dimensions	Approx. 56 mm (W) × 49 mm (H) × 24 mm (D) (2.2 in. (W) × 1.9 in. (H) × 0.9 in. (D))
Weight	Approx. 35 g (1.2 oz)

Image Storage Capacity

The following table shows the approximate number of images and recording time (in seconds) of movies that can be saved in the internal memory and a memory card in various formats.

	Recorded Pixels	Aspect Ratio	Internal Memory			Memory Card (8 GB)		
			☆☆☆☆	☆☆☆	☆☆	☆☆☆☆	☆☆☆	☆☆
Still Image	L	4:3	856	1478	2320	936	1616	2537
		3:2	963	1659	2599	1053	1815	2843
		1:1	1135	1961	3039	1242	2145	3324
	M	4:3	1699	2916	4495	1858	3189	4917
		3:2	1909	3220	5018	2088	3522	5488
		1:1	2247	3785	5832	2458	4140	6378
	S	4:3	2877	5394	7441	3146	5900	8138
		3:2	3220	5994	8299	3522	6556	9077
		1:1	3853	7193	9809	4214	7867	10728
	XS	4:3	4404	8299	10789	4816	9077	11801
		3:2	4904	8991	11988	5364	9834	13112
		1:1	6539	11357	15414	7152	12422	16858
	2M	4:3	6961	11988	15414	7613	13112	16858
	1M	4:3	8299	14386	17983	9077	15734	19668
	VGA	4:3	30828	53949	71933	33717	59005	78673
3:2		35966	53949	71933	39336	59005	78673	
1:1		43159	71933	71933	47204	78673	78673	

	Recorded Pixels	Framerate	Internal Memory	Memory Card (8 GB)	
Movie	3840	30 fps	00:09:26	00:10:19	
	1920	30 fps	00:47:36	00:52:04	
		1280	60 fps	00:47:36	00:52:04
			30 fps	01:18:41	01:26:04
			120 fps	00:29:52	00:32:41



Caution

- The figures for movies are the total length that can be recorded. The maximum recording time per shooting is 25 minutes or the equivalent of 4 GB.
- The number of images that can be captured may differ from the number of storable images displayed on the monitor.
- The storage capacity varies depending on the shooting conditions and the capacity of the memory.
- The number of images storable in a tamper-proof card is smaller than that in a normal memory card.
- The memory cards with which proper operation has been confirmed are listed below.

Recorded Pixels/Capture Mode	Memory Card Speed Class
4K 30fps	UHS Speed Class 3 or faster
FullHD 30fps, HD 60fps [High Speed Movie] in the SCN mode	Speed Class 4 or faster
HD 30fps	Speed Class 2 or faster

- If a movie is recorded with a memory card with which proper operation has not been confirmed, the movie recording stops when writing to the card is delayed. (The movie recorded by the time the recording stops is saved.) If a movie is played back with such a card, the playback sound does not synchronize with the video.

Operating Environment

It is confirmed that a USB connection can be established between the camera and the following OSs.

Windows®	Windows® 10 (FCU, CU) (32-bit, 64-bit), Windows® 8.1 (32-bit, 64-bit), Windows® 8 (32-bit, 64-bit), or Windows® 7 (32-bit, 64-bit)
Mac	macOS 10.14 Mojave, macOS 10.13 High Sierra, macOS 10.12 Sierra, OS X 10.11 El Capitan, OS X 10.10 Yosemite



Caution

- The provided software is compatible with Windows® only.

Using the Camera Abroad

USB Power Adapter (AC-U1/AC-U2), AC Adapter (K-AC166), and Battery Charger (BJ-11)

These products are for use with currents of 100 to 240 V and 50 or 60 Hz. Before traveling, purchase a travel adapter for connection to the type of outlets used at your destination.

Do not use these products with electrical transformers, as this could damage the camera.

Television Playback

Captured images can be played back on the televisions and monitors equipped with a video input terminal. Use a commercially available HDMI® cable. Use an HDMI® cable with a length of 3 m or less (recommended product: RP-CHEU15-K manufactured by Panasonic). The RICOH HDMI cable HC-1 cannot be used.

Precautions for Use

Waterproof and Dustproof Function

- The camera complies with JIS/IEC waterproof grade 8 and JIS/IEC dustproof grade 6 (IP68).
- After shooting in the rain or washing with water, water may leak out from the lens barrel or the tripod screw hole on the bottom of the camera. However, this is not problematic because the camera is protected with the double-layered structure.
- The interior of the camera does not have the waterproof/dustproof structure. If water enters inside the camera, immediately remove the battery and consult your nearest repair center.

Camera

- When opening and closing the battery/card cover, be sure to remove water and dirt such as sand, mud, and dust adhering to the camera, and ensure that water or dirt does not enter the camera interior. Do not open the cover of the camera on the beach, at sea, or in a sandy area. If the cover is opened, seawater or sand may enter the camera.
- When opening and closing the battery/card cover, do not wear cotton work gloves. Dirt such as sand and dust adhering to the gloves may enter the camera interior. Also, be sure to remove water and dirt such as sand and mud adhering to the camera, and avoid locations where dirt can enter the camera interior.
- When the cover is opened, water droplets may be on the inside of the cover. In this case, clean them out before use.
- If the mode dial is not operated for a long time, it may become difficult to turn due to its waterproof structure. Turning the dial several times recovers the smooth dial operation.
- On the beach or in dusty places such as a construction site, be careful to keep the camera away from sand and dust.
- Do not leave the camera in places where temperature abnormally rises or in places in high humidity, such as in a car, on the beach, and in a bathroom.
- Ensure that the camera is turned off before connecting the optional AC adapter.
- Do not pull the battery/card cover forcefully.
- Do not hold the battery/card cover when carrying the camera.
- If any metallic object, water, liquid, or other foreign object gets into the camera, immediately stop using the camera. Turn the camera off, remove the battery and memory card from the camera, and contact your nearest dealer or service center for repair.
- In cold climates, water droplets on the camera may freeze. Using the camera with frozen water droplets could result in product malfunction. Do not leave the camera with water droplets.
- Do not drop the camera or subject it to physical shocks.

- When carrying the camera, be careful that it does not strike other objects. Particular care is required to protect the lens and monitor.
- The flash may overheat if fired many times in succession. Do not use the flash successively more than necessary.
- Do not use the flash in close contact with your body or other objects. Failure to observe this precaution could result in burns or fire.
- Using the flash unit in close proximity to your subject's eyes could cause temporary visual impairment. Particular care should be observed when photographing infants.
- Do not direct the flash at the operator of a motor vehicle. Failure to observe this precaution could cause accidents.
- Battery may become hot with extended use. Wait for the battery to cool before removing it from the camera.
- The monitor may be difficult to read in direct sunlight.
- You may notice that monitor varies in brightness or contains pixels that do not light or that are always lit. This is common to all LCD monitors and does not indicate a malfunction.
- Do not apply force to the monitor.
- Abrupt changes in temperature may cause condensation, resulting in visible condensation inside the lens or camera malfunction. This can be avoided by placing the camera in a plastic bag to slow the temperature change, and removing it only after the air in the bag has reached the same temperature of its surroundings. When condensation occurs, remove the battery and memory card from the camera, and wait until water droplets disappear.
- To prevent damage to the product, do not insert objects into the holes in the microphone and speaker coverings.
- Take a test shot to ensure that the camera is functioning properly before using it on important occasions such as travel or weddings. We recommend that you keep this manual and spare batteries at hand.



Conditions that May Cause Condensation-----

- If you move to an area with a sharply different temperature
- If humidity is high
- In a cold room after the heater has come on, or where the camera is exposed to cold air from an air conditioner or other device

USB Power Adapter AC-U1/AC-U2

- Use the USB cable contained in the package.
- Do not subject the power adapter to severe impact or force.
- Do not use in extreme high or low temperatures or areas subject to vibration.
- Do not use in an area subject to direct sunlight or high temperature.
- Unplug the power plug from the power outlet after charging. Failure to observe this precaution could result in fire.

- Do not allow other metallic objects to come in contact with the connectors, or contacts of the rechargeable battery as this can result in a short.
- The operating temperature range is 10 to 40°C (50 to 104°F). Charging takes longer at temperatures below 10°C (50°F).

Rechargeable Battery DB-110

- This is a lithium-ion battery.
- The battery is not fully charged at the time of purchase, so be sure to charge the battery before use.
- Do not open or damage the battery as this can result in fire or injury. In addition, do not heat the battery above 60°C (140°F) or expose the battery to fire.
- Due to the battery characteristics, the battery usage time may be shortened when used in a cold environment, even if the battery is fully charged. Keep the battery warm by placing it in a pocket or have a backup battery ready.
- When not in use, be sure to remove the battery from the camera or the battery charger. A small amount of current can leak from the battery even when the power is off, creating excessive discharge and making the battery unusable. If the battery is removed for more than five days, the date and time settings will be lost. In this case, reset the date and time.
- If the battery is not used for a long time, charge the battery for 15 minutes once a year before storing.
- Store in a dry, cool place with an ambient temperature between 15°C and 25°C (59°F and 77°F). Avoid storing in extreme high or low temperatures.
- After charging the battery, do not immediately charge it again.
- Charge the battery at an ambient temperature between 10°C and 40°C (50°F and 104°F). Charging the battery at a high temperature can deteriorate the battery. Charging at a low temperature may prevent full charging.
- If the battery usage time becomes very short even when fully charged, the battery has reached the end of its service life. Replace with a new battery. Be sure to use a replacement battery recommended by RICOH.
- The recharge time with the camera using the AC-U1/AC-U2 is approximately 3 hours (at 25°C (77°F)).



Caution

- Use of other batteries can cause explosion.
- Recycle used batteries in a recycle box at your local electronics store or supermarket.

Battery Charger BJ-11

- Do not charge batteries other than the rechargeable lithium-ion battery DB-110. Charging other types of batteries may cause an explosion or heating, or may damage the product.
- If the battery is correctly inserted but the indicator lamp does not light, the battery may be faulty. Replace it with a new battery. If the indicator lamp still does not light with the new battery, the battery charger may be faulty. Contact your nearest service center.
- When charging is completed, unplug the power adapter from the power outlet.
- The battery may become hot during charging, but this is not a malfunction.
- Do not charge the battery in a poor heat radiating environment, such as in a desk.
- If the battery starts to run down more quickly even after being fully charged, it has reached the end of its service life. Replace it with a new battery.
- Charge the battery in a location where the temperature is between 10°C and 40°C (50°F and 104°F). (The charging time depends on temperature and remaining battery power.)
- If the rechargeable lithium-ion battery DB-110 is not used for six months or longer, store it separately from the camera. Charge the removed battery for about 30 minutes using the battery charger.
Be sure to recharge the battery every six to twelve months. Also, store the battery in a location where the temperature will remain at or below room temperature. Avoid locations with high temperatures.
- The recharge time with the BJ-11 is approximately 2.5 hours (at 25°C (77°F)).

Camera Care and Storage

Caring for the Camera

- Image quality can be affected by fingerprints and other foreign matter on the lens. Avoid touching the lens with your fingers.
- Remove dust or lint on the lens with a commercially available blower, or gently clean the lens with a soft, dry cloth.
- When the camera becomes dirty or after using it on the beach, ensure that the battery/card cover is closed, and then rinse off dirt, sand, and salt in a basin of tap water and wipe off the moisture with a soft, dry cloth.
- When the rubber packing becomes dirty, clean it with soft, dry cloth. Dirt adhering to the rubber packing or scratches on it may deteriorate the waterproof function, causing water leakage. When the dirt cannot be cleaned or you find scratches on the rubber packing, take the camera to your nearest dealer or service center to replace it with a new packing.
- In the unlikely event of malfunction, consult your nearest repair center.
- The camera contains high-voltage circuits. Do not disassemble it.
- Do not expose the camera to volatile substances such as thinner, benzene, or pesticides. Failure to observe this precaution could result in damage to the camera or its coatings.
- The monitor is easily scratched, avoid touching it with hard objects.
- Clean the monitor by wiping it with a soft cloth dampened with a small amount of any monitor cleaner that does not contain organic solvents.

Storage

- Do not store the camera where it will be exposed to:
 - Extreme heat or humidity, large changes in temperature or humidity
 - Dust, dirt, sand
 - Severe vibration
 - Prolonged contact with chemicals including pesticides, or with vinyl or rubber products
 - Strong magnetic fields (for example, in the vicinity of a monitor, transformer, or magnet)
- Store the camera in a lint-free camera case, etc. to prevent dirt and lint from adhering to the camera. Do not carry the camera in a pocket to prevent dirt and lint from adhering to the camera.
- Remove the battery if the product is left unused for a long period of time.

Replacement of Rubber Packings

- Replace the rubber packing with a new one every two years even if it is not dirty and there is no problem with it, to maintain the waterproof function. When the camera is frequently used in water, in a sandy area, or in a dusty room, it is recommended to replace it every year. Contact your service center to replace the rubber packing. (A fee will be charged for the replacement.)

Before Cleaning

- Be sure to turn the camera off.
- Remove the battery and AC adapter from the camera.

Warranty Policy

All our cameras purchased through authorized bona fide photographic distribution channels are guaranteed against defects of material or workmanship for a period of twelve months from the date of your purchase. Service will be rendered, and defective parts will be replaced without cost to you within that period, provided the camera does not show evidence of impact, sand or liquid damage, mishandling, tampering, battery or chemical corrosion, operation contrary to operating instructions, or modification by an unauthorized repair shop. The manufacturer or its authorized representatives shall not be liable for any repair or alterations except those made with its written consent and shall not be liable for damages from delay or loss of use or from other indirect or consequential damages of any kind, whether caused by defective material or workmanship or otherwise; and it is expressly agreed that the liability of the manufacturer or its representatives under all guarantees or warranties, whether expressed or implied, is strictly limited to the replacement of parts as hereinbefore provided. No refunds will be made on repairs by non-authorized service facilities.

Procedure During 12-month Warranty Period

Any camera which proves defective during the 12-month warranty period should be returned to the dealer from whom you purchased the camera or to the manufacturer. If there are no representatives of the manufacturer in your country, send the camera to the manufacturer, with postage prepaid. In this case, it will take a considerable length of time before the camera can be returned to you owing to the complicated customs procedures required. If the camera is covered by warranty, repairs will be made and parts replaced free of charge, and the camera will be returned to you upon completion of servicing. If the camera is not covered by warranty, regular charges of the manufacturer or of its representatives will apply. Shipping charges are to be borne by the owner. If your camera was purchased outside of the country where you wish to have it serviced during the warranty period, regular handling and servicing fees may be charged by the manufacturer's representatives in that country. Notwithstanding this, your camera returned to the manufacturer will be serviced free of charge according to this procedure and warranty policy. In any case, however, shipping charges and customs clearance fees to be borne by the sender. To prove the date of your purchase when required, please keep the receipt or bills covering the purchase of your camera for at least a year. Before sending your camera for servicing, please make sure that you are sending it to the manufacturer's authorized representatives or their approved repair shops, unless you are sending it directly to the manufacturer. Always obtain a quotation for the service charge, and only after you accept the quoted service charge, instruct the service station to proceed with the servicing.

- **This warranty policy does not affect the customer's statutory rights.**
- **The local warranty policies available from our distributors in some countries can supersede this warranty policy. Therefore, we recommend that you review the warranty card supplied with your product at the time of purchase, or contact our distributor in your country for more information and to receive a copy of the warranty policy.**

Regulatory Compliance Statements

For Customers in USA

STATEMENT OF FCC COMPLIANCE

This device complies with Part 15 of the FCC Rules. Operation is subject to the following two conditions: (1) This device may not cause harmful interference, and (2) this device must accept any interference received, including interference that may cause undesired operation.

Changes or modifications not expressly approved by the party responsible for compliance could void the user's authority to operate the equipment.

This equipment has been tested and found to comply with the limits for a Class B digital device, pursuant to part 15 of the FCC Rules. These limits are designed to provide reasonable protection against harmful interference in a residential installation. This equipment generates, uses and can radiate radio frequency energy and, if not installed and used in accordance with the instructions, may cause harmful interference to radio communications. However, there is no guarantee that interference will not occur in a particular installation. If this equipment does cause harmful interference to radio or television reception, which can be determined by turning the equipment off and on, the user is encouraged to try to correct the interference by one or more of the following measures:

- Reorient or relocate the receiving antenna.
- Increase the separation between the equipment and receiver.
- Connect the equipment into an outlet on a circuit different from that to which the receiver is connected.
- Consult the dealer or an experienced radio/TV technician for help.

This transmitter must not be co-located or operated in conjunction with any other antenna or transmitter.

The available scientific evidence does not show that any health problems are associated with using low power wireless devices. There is no proof, however, that these low power wireless devices are absolutely safe. Low power Wireless devices emit low levels of radio frequency energy (RF) in the microwave range while being used. Whereas high levels of RF can produce health effects (by heating tissue), exposure of low-level RF that does not produce heating effects causes no known adverse health effects. Many studies of low-level RF exposures have not found any biological effects. Some studies have suggested that some biological effects might occur, but such findings have not been confirmed by additional research. R02070 has been tested and found to comply with FCC radiation exposure limits set forth for an uncontrolled environment and meets the FCC radio frequency (RF) Exposure Guidelines.

CAUTION: RF Exposure

To ensure compliance with the Radio Frequency (RF) exposure guidelines, this device must be used at least 5 mm away from your body or nearby persons. Failure to observe this warning could result in the RF exposure levels exceeding the applicable limits.

Declaration of Conformity According to 47CFR, Parts 2 and 15 for Class B Personal Computers and Peripherals

We: RICOH IMAGING AMERICAS CORPORATION
Located at: 5 Dedrick Place, West Caldwell,
New Jersey 07006, U.S.A.
Phone: 800-877-0155
FAX: 973-882-2008

Declare under sole responsibility that the product identified herein complies with 47CFR Parts 2 and 15 of the FCC rules as a Class B digital device. Each product marketed is identical to the representative unit tested and found to be compliant with the standards. Records maintained continue to reflect the equipment being produced can be expected to be within the variation accepted, due to quantity production and testing on the statistical basis as required by 47CFR §2.909. Operation is subject to the following two conditions: (1) This device may not cause harmful interference, and (2) This device must accept any interference received, including interference that may cause undesired operation. The above named party is responsible for ensuring that the equipment complies with the standards of 47CFR §15.101 to §15.109.

Product Name: Digital Camera
Model Number: R02060/R02070
Contact person: Customer Service Manager
Date and Place: May, 2019 West Caldwell

For Customers in Canada Innovation, Science and Economic Development Canada (ISED) Regulatory Compliance Notice

This Class B digital apparatus complies with Canadian ICES-003 (B).

This device complies with Innovation, Science and Economic Development Canada licence-exempt RSS standard(s). Operation is subject to the following two conditions: (1) this device may not cause interference, and (2) this device must accept any interference received, including interference that may cause undesired operation.

The available scientific evidence does not show that any health problems are associated with using low power wireless devices. There is no proof, however, that these low power wireless devices are absolutely safe. Low power wireless devices emit low levels of radio frequency energy (RF) in the microwave range while being used. Whereas high levels of RF can produce health effects (by heating tissue), exposure of low-level RF that does not produce heating effects causes no known adverse health effects. Many studies of low-level RF exposures have not found any biological effects. Some studies have suggested that some biological effects might occur, but such findings have not been confirmed by additional research. The R02070 has been tested and found to comply with ISED radiation exposure limits set forth for an uncontrolled environment and meets RSS-102 of the ISED radio frequency (RF) Exposure rules.

7

Appendix

CAUTION: RF Exposure

To ensure compliance with the Radio Frequency (RF) exposure guidelines, this device must be used at least 5 mm away from your body or nearby persons. Failure to observe this warning could result in the RF exposure levels exceeding the applicable limits.

Pour les utilisateurs au Canada

Avis de conformité à la réglementation d'Innovation, Sciences et Développement économique Canada (ISDE)

Cet appareil numérique de la classe B est conforme à la norme NMB-003 (B) du Canada.

Le présent appareil est conforme aux CNR d'Innovation, Sciences et Développement économique Canada applicables aux appareils radio exempts de licence. L'exploitation est autorisée aux deux conditions suivantes : (1) l'appareil ne doit pas produire de brouillage, et (2) l'utilisateur de l'appareil doit accepter tout brouillage radioélectrique subi, même si le brouillage est susceptible d'en compromettre le fonctionnement.

Les connaissances scientifiques dont nous disposons n'ont mis en évidence aucun problème de santé associé à l'usage des appareils sans fil à faible puissance. Nous ne sommes cependant pas en mesure de prouver que ces appareils sans fil à faible puissance sont entièrement sans danger. Les appareils sans fil à faible puissance émettent une énergie fréquence radioélectrique (RF) très faible dans le spectre des micro-ondes lorsqu'ils sont utilisés. Alors qu'une dose élevée de RF peut avoir des effets sur la santé (en chauffant les tissus), l'exposition à de faibles RF qui ne produisent pas de chaleur n'a pas de mauvais effets connus sur la santé. De nombreuses études ont été menées sur les expositions aux RF faibles et n'ont découvert aucun effet biologique. Certaines études ont suggéré qu'il pouvait y avoir certains effets biologiques, mais ces résultats n'ont pas été confirmés par des recherches supplémentaires. Le R02070 a été testé et jugé conforme aux limites d'exposition aux rayonnements ISDE énoncées pour un environnement non contrôlé et respecte les règles d'exposition aux fréquences radioélectriques (RF) CNR-102 de l'ISDE.

ATTENTION : Exposition aux RF

Pour garantir la conformité avec les directives d'exposition aux fréquences radioélectriques (RF), cet appareil doit être utilisé à au moins 5 mm de votre corps ou des personnes se trouvant à proximité. Le non-respect de cet avertissement peut entraîner des niveaux d'exposition aux RF supérieurs aux limites applicables.

For Customers in Europe Information for Users on Collection and Disposal of Old Equipment and Used Batteries



1. In the European Union

These symbols on the products, packaging and/or accompanying documents mean that used electrical and electronic equipment and batteries should not be mixed with general household waste.

Used electrical/electronic equipment and batteries must be treated separately and in accordance with legislation that requires proper treatment, recovery and recycling of these products.

By disposing of these products correctly you will help ensure that the waste undergoes the necessary treatment, recovery and recycling and thus prevent potential negative effects on the environment and human health which could otherwise arise due to inappropriate waste handling.

If a chemical symbol is added beneath the symbol shown above, in accordance with the Battery Directive, this indicates that a heavy metal (Hg = Mercury, Cd = Cadmium, Pb = Lead) is present in the battery at a concentration above an applicable threshold specified in the Battery Directive.

For more information about collection and recycling of used products, please contact your local authorities, your waste disposal service or the point of sale where you purchased the products.

2. In other countries outside the EU

These symbols are only valid in the European Union. If you wish to discard used products, please contact your local authorities or dealer and ask for the correct method of disposal.

For Switzerland: Used electrical/electronic equipment can be returned free of charge to the dealer, even when you don't purchase a new product. Further collection facilities are listed on the home page of www.swico.ch or www.sens.ch.

Notice to Users in EEA Countries

This product complies with the essential requirements and provisions of RE Directive 2014/53/EU.

The CE Declaration of Conformity is available by accessing the URL:

http://www.ricoh-imaging.co.jp/english/support/declaration_of_conformity.html
and selecting the product applicable.

Operating frequency: 13.56 MHz

Maximum radio-frequency power : 58.8 dBuA/m (at 3 m)

Operating frequency band: 2400 MHz – 2483.5 MHz

Maximum radio-frequency power: 17.59 dBm EIRP

Operating frequency band: 5150 MHz – 5250 MHz (W52)

Maximum radio-frequency power: 17.81 dBm EIRP

European importer: RICOH IMAGING EUROPE S.A.S.

Parc Tertiaire SILIC 7-9, avenue Robert Schuman - B.P. 70102, 94513 Rungis Cedex,
FRANCE

Manufacturer: RICOH COMPANY, LTD.

1-3-6, Nakamagome, Ohta-ku, Tokyo 143-8555, JAPAN

Simplified Declaration of Conformity

This product complies with the essential requirements and provisions of RE Directive 2014/53/EU.

The CE Declaration of Conformity is available by accessing the URL:

http://www.ricoh-imaging.co.jp/english/r_dc/support/ce_docs/

and selecting the product applicable.

	AT	EE	IE	NL	ES	CH
	BE	FI	IT	PL	SE	HR
	BG	FR	LV	PT	UK	TR
	CY	DE	LT	RO	IS	
	CZ	EL	LU	SK	LI	
	DK	HU	MT	SI	NO	

G900SE only:

- Do not use the 5 GHz band (W52) of wireless LAN outdoors in the countries listed above. The outdoor use of the W52 is prohibited by law in these countries. Use the 2.4 GHz band for outdoors.
- The frequency range used by this product is limited to 5150 to 5250 MHz (W52) in the 5 GHz band.



The CE Mark is a Directive conformity mark of the European Union.

Index

Numerics

1cm Macro	49
10 Keyboard	126

A

A-Bracket	61
AC adapter	134
Adding title picture	89
ADJ. button	23, 107
ADJ Button Setting	107
ADJ. mode	23
AE Metering	52
AF	50
Anti Red-eye (Flash)	54
AP Connection Timeout	103
Append CRC	103
Aspect Ratio	62
Assist (Face Detection)	50
Auto Delete	96
Auto Image Rotation	81
Auto Macro	49
Auto mode	42
Auto Power Off	111
AUTO Range	53
Auto WB (White Balance)	56
AV device	82

B

Barcode	126
Battery	34, 37
Blink Detection	42
Bluetooth®	100
Board	71
Bright (Image Tone)	63
Burst Shoot	59
Button	16

C

Calendar display	79
Calibrate Level	109
CALS mode	44
CALS Pixels	44
CALS Quality	44
Camera Admin. Lock	130
Camera Memo	68
Camera Memo Imprint	126

Camera Memo Mode	125
Camera route	115
Camera Settings File	106
Camera User Lock Op.	130
Capture mode	44
Card	34
Card PW Unlock Time	132
Care	153
Center (AE Metering)	52
Certifications	3
Changing display	20
Charging the battery	37
Cloudy (White Balance)	56
Communication Mode	96
Compass Calibration	117
Compass Heading	117
Compositing images	77
Confirm. Time	42
Connection Power On	96
Connection to a computer	92
Contrast	64
Cont. Shoot	59
Copyright Info	122
Copyright Print	123
Correcting a range of tones	65
Create Log File	103
Cropping	87
Cursor Position Keeping	25
Customization	107
Customize menu	29

D

Data Imprint	117
Date and time setting	40
Date Imprint	64
Daylight (White Balance)	56
Declination	117
Delete	43, 83
Destination	124
Dial	16
Digital Filter	88
Digital microscope mode	44
Digital SR (Scene)	45
Digital zoom	43
Direct keys	22
Discard log data	116
Divide (AE Metering)	52
Divide Movies	89
DL-20	94

DOF Composite (Scene).....	45	High Speed Movie (Scene).....	45
D-Range Setting	65	I	
Drive Mode	58	IC card.....	128
E		Image Clip.....	75
Edit Detection.....	67	Image Copy	84
Editing images.....	86	Image File Size.....	96
Embed Info	122	Image Sync	97
EV Comp.	46	Image Tone	63
EX2	94	IMAGE Transmitter 2	95
Exif	122	Import Com. Setting.....	98
Expanded Settings menu.....	31	Infinity (Focus).....	49
F		Initialized Setting	25
Face Detection.....	50	Initial settings	39
File name	120	Ink Rubbing Filter	88
File Send	101	Instant Review.....	42
File Sequence No.	121	Intelligent zoom.....	43
Filter.....	88	Internal memory.....	35
Firefighting (Scene)	45	Interval Movie (Scene).....	45
Flash	54	Interval Shooting (Scene).....	45
FlashAir.....	35	IQ Enhancer	64
Flash Off (Flash).....	54	L	
Flash On (Flash).....	54	Language setting	40
Fluorescent (White Balance).....	56	LAT/LON (GPS).....	115
Fn button	23, 108	LCD Brightness	110
Fn Setting.....	108	LE2	94
Focus Assist.....	50	Lens Adapter On.....	133
Focus Mode	49	Level Setting.....	109
Folder display.....	79	Location Data.....	114
Format	40	M	
G		Macro	49
GPS.....	114	Macro stand.....	13
GPS Data Imprint	117	Magnifying captured image.....	43
GPS Disp Mode.....	115	Manual focus.....	51
GPS Lock	115	Manual WB (White Balance)	57
GPS Log.....	115	Mark Memo Added	125
GPS Time Adjustment.....	115	M-Cont	59
Grid Guide Display Op.	109	ME2.....	94
Guide Display.....	46	Memo 1 Auto Delete.....	126
H		Memo at Startup.....	125
HDMI Out.....	82	Memo Increment.....	125
HDR Filter.....	88	Memo Overwrite	126
HDR (Movie)	62	Memory card	34
HDR (Scene).....	45	Memory retrospective continuous shooting	59
Heading Data Imprint.....	117	Memo Skip.....	125
Highlight Cor.....	65	Memo Warning.....	125

Menu.....	24
Menu Button Setting.....	25
MF (Focus).....	51
MGRS (GPS).....	115
Microphone.....	47, 62
Monitor.....	18
Monitor Auto off Delay.....	111
Monochrome (Image Tone).....	63
Movie.....	47
Movie Edit.....	89
Movie menu.....	27
Movie SR.....	65
Multi (AF).....	50
Multiple image display.....	79

N

Natural (Image Tone).....	63
Network menu.....	32
New folder options.....	118
NFC.....	128
NFC Setting.....	128
Number of Retries.....	103

O

Operating environment.....	147
Operation Log.....	103
Operation Volume.....	110
Optical zoom.....	43
OSS Information.....	32
Outdoor View.....	110

P

Package contents.....	13
Password.....	129
PF (Focus).....	49
PING.....	103
Pix. Track SR.....	65
Playback.....	43, 79
Playback menu.....	28
Playback Volume.....	110
P mode.....	44
Power.....	39
Power Button Hold Op.....	39
Power Button Lamp.....	39, 110
Power Saving.....	111
Processing images.....	86
Program mode.....	44
Protect.....	85
PW Validity Period.....	132

Q

Quality Level.....	62
Quick Send Mode.....	102
Quick Zoom.....	43

R

Range finder.....	100
Recorded Pixels.....	62
Record log.....	115
Recover File.....	84
Red-eye Edit.....	91
Remote Ctl.....	60
Remote Photography.....	97
Remove Haze (Scene).....	45
Remove Memo Marking.....	125
Reset.....	25
Reset File Number.....	121
Resize.....	86
Restore Defaults.....	62
Retain WLAN Conn.....	103
Ring Light.....	55
Ring Light (White Balance).....	57
Rotation.....	81

S

Saturation.....	64
Save as Still Image.....	89
Save log data.....	116
Saving power.....	111
Scene mode.....	45
SCN mode.....	45
S-Cont.....	59
SD memory card.....	34
Security.....	129
Self-timer.....	58
Send Status.....	98
Send To.....	98
Sensitivity.....	53
Server Sync.....	103
Set/Edit Admin. PW.....	129
Set/Edit SD Card PW.....	131
Set/Edit User PW.....	129
Setting.....	53
Setup menu.....	30
Shade (White Balance).....	56
Shadow Cor.....	65
Sharpness.....	64
Shooting menu.....	26

Show folder at startup	109
Shut-down Screen	109
Simple Connection	99
Single image display	43
Skew Correction.....	66
Slide Film (Image Tone)	63
Slideshow	80
Small Face Filter	88
Smile (Face Detection).....	50
Software.....	94
Sound	110
Sound volume	110
Specifications.....	141
Spot (AE Metering).....	52
Spot (AF)	50
SR-20	94
SR-20 server.....	103
ST-20.....	94
START DATE/TIME	109
Start-up Screen	109
Storage.....	153
Storage capacity	38, 146
Streaming continuous shooting	59
Support.....	103
Surf & Snow (Scene)	45
Synchronize Clock.....	103

T

Tamper-proof card	36
Tamper-proofing	36
Template	73
Text Mode (Scene).....	45
Thumbnail display.....	79
Tone Adjustment.....	64
Tracking (AF)	50
Transmit Power Off	96
Transparency.....	74
Tungsten (White Balance)	57
TV	82

U

Update Firmware.....	103
Update Settings	104
USB cable.....	92
USB Connection	92
USB power adapter.....	37
User mode.....	105
UTC Data Imprint.....	117
UTM (GPS)	115

V

Version Info.....	30
Vibrant (Image Tone).....	63

W

Warranty Policy	155
Watermark Options	73
White Balance	56
Wide conversion lens.....	133
Wind Suppression	62
Wireless LAN.....	98
World Time.....	124

Z

Zoom.....	43
Zoom Macro (Scene)	45

RICOH IMAGING COMPANY, LTD.

1-3-6, Nakamagome, Ohta-ku, Tokyo 143-8555,
JAPAN
(<http://www.ricoh-imaging.co.jp>)

**RICOH IMAGING EUROPE
S.A.S.**

Parc Tertiaire SILIC 7-9, avenue Robert Schuman -
B.P. 70102, 94513 Rungis Cedex, FRANCE
(<http://www.ricoh-imaging.eu>)

**RICOH IMAGING
AMERICAS CORPORATION**

5 Dedrick Place, West Caldwell, New Jersey 07006,
U.S.A.
(<http://www.us.ricoh-imaging.com>)

**RICOH IMAGING CANADA
INC.**

5560 Explorer Drive Suite 100, Mississauga, Ontario,
L4W 5M3, CANADA
(<http://www.ricoh-imaging.ca>)

**RICOH IMAGING CHINA
CO., LTD.**

Room A 23F Lansheng Building, 2-8 Huaihaizhong
Road, Huangpu District, Shanghai, 200021, CHINA
(<http://www.ricoh-imaging.com.cn>)

<http://www.ricoh-imaging.co.jp/english>

This contact information may change without
notice. Please check the latest information on our
websites.

RICOH COMPANY, LTD.
June, 2019

En

Printed in Indonesia



* F 3 G C 1 9 5 2 A *