

Ready State After Printing

You can specify the state the printer return to after printing documents during Sleep Mode.

- Control Panel On

The printer does not return to Sleep Mode and the initial screen appears on the control panel.

- Cntrl Panel Off (EngySavg)

The printer returns to Sleep Mode.

Low Power Mode Level

Specify the Low Power Mode Level. Starting up time and power consumption will differ according to this level.

Default: [Level 2]

- Level 1
- Level 2

When "Level 1" is specified, electricity consumption will be lower than that of normal stand by state.

When "Level 2" is specified, this machine returns from stand-by mode within 30 seconds.

Stop Print at Output Limit

Select whether to stop printing when the number of printed sheets reaches the capacity number of the output tray. Stopping will prevent overflow and mixing of sheets on the output tray.

To resume printing, remove the printed sheets from the output tray, and then press [Carry On] on the control panel.

Printing stops when the maximum number is reached, even if the prints have been removed from the output tray during the print run. The maximum number of sheets that can be printed at one time is approximately 150.

If the maximum number of output sheets is reached while printing a particular type of list, printing will be canceled without the machine displaying a message.

Default: [Inactive]

- Active
- Inactive

Bypass Print:64-90 mm

Select [Active] when printing on paper whose width is less than 90 mm. To print on paper of another size, select [Inactive].

Default: [Inactive]

- Active
- Inactive

B&W Print Priority

You can specify whether or not to reduce the consumption of color toner. When this function is enabled, it may take longer to start printing a color page.

Default: [Off]

- On
- Off

Anti-Humidity

Select whether or not to reduce paper curl and print smearing when printing in a high-humidity environment.

Anti-Humidity Setting

Default: [Off]

- On
- Off

Anti-Humidity Level

Default: [Level 1 (Weak)]

- Level 1 (Weak)
- Level 2 (Medium)
- Level 3 (Strong)

Print Compressed Data

You can specify whether or not to print compressed data. The supported compression format is GZIP.

Default: [Off]

- On
- Off

Memory Usage

You can specify whether or not to use memory from Font Priority or Frame Priority.

Default: [Frame Priority]

- Font Priority
Allocates more memory to the PDL work area. Select this setting if printing fails due to insufficient memory.
- Frame Priority
Allocates more memory for image processing. Select this setting to increase print speed. Depending on the document you are printing, this setting might not be effective.

B&W Page Detect

You can specify whether to recognize black-and-white images by page or by document. The black-and-white recognition function allows the printer to print monochrome images in monochrome mode even if color printing is specified.

Default: [**Per Job**]

- Per Page
- Per Job
- Off

RAM Disk

If the hard disk is not installed for PDF Direct Print, select a value of 2 MB or higher.

Default: [**4 MB**]

- 0 MB
- 2 MB
- 4 MB
- 8 MB
- 16 MB

Auto E-mail Notify

You can specify whether or not to send an error message to a preset e-mail address when a printer error occurs. After changing the setting, turn off the power of the printer briefly, and then turn it on again. For information, see Web Image Monitor Help.

Default: [**On**]

- On
- Off

Main Pwr Off if Ntwrk Disc

xxxxxxx

Default: [**On**]

- On
- Off

Serial No. of Machine

You can check the serial number of the printer.

Print Settings (SP C340DN)

This section describes the parameters that can be set on [Print Settings].

Machine Modes (SP C340DN)

Copies

You can specify the number of copies to print.

If the number of copies to print is specified by command or the printer driver, this setting is overridden.

Default: 1

- 1 to 999

Page Size

You can specify the default paper size. The default paper size is used when the paper size is not specified in the print data.

Default:

 **Region A** (mainly Europe and Asia)

A4

 **Region B** (mainly North America)

8¹/₂ × 11

-  **Region A** (mainly Europe and Asia)

A4, A5, A6, B5 JIS, B6 JIS, C5 Env, C6 Env, DL Env, 8¹/₂ × 14, 8¹/₂ × 13²/₅, 8¹/₂ × 13, 8¹/₂ × 12, 8¹/₂ × 11, 8¹/₄ × 13, 8 × 13, 7¹/₄ × 10¹/₂, 5¹/₂ × 8¹/₂, 4¹/₈ × 9¹/₂, 3⁷/₈ × 7¹/₂, 16K, Custom Size

-  **Region B** (mainly North America)

8¹/₂ × 14, 8¹/₂ × 13²/₅, 8¹/₂ × 13, 8¹/₂ × 11, 8¹/₄ × 13, 8 × 13, 7¹/₄ × 10¹/₂, 5¹/₂ × 8¹/₂, 4¹/₈ × 9¹/₂, 3⁷/₈ × 7¹/₂, A4, A5, A6, B5 JIS, B6 JIS, C5 Env, C6 Env, DL Env, 16K, Custom Size

Duplex

You can specify whether or not to print on both sides of a sheet. If you specify duplex printing, you must also specify the binding method.

Default: [None]

- None
- Long Edge Bind
- Short Edge Bind

Rotate by 180 Degrees

You can specify whether or not to rotate the print image by 180 degrees.

Default: [Off]

- On
- Off

Blank Page Print

You can specify whether or not to print blank pages.

Default: **[On]**

- On
- Off

Letterhead Setting

You can specify whether or not to print on paper that has a fixed print side or print direction (letterhead paper, for example). For details, see page 121 "Loading Orientation-Fixed Paper or Two-Sided Paper".

Default: **[Auto Detect]**

- Off

The letterhead printing mode is disabled.

- Auto Detect

You can specify whether or not to print using letterhead mode whenever a page that has a fixed print side or print direction is specified as the first page.

- On (Always)

Print with the letterhead printing mode regularly.

Tray Setting Priority

You can specify whether or not the paper size and type settings that are applied are those specified using the control panel, printer driver, or print command.

Bypass Tray

You can specify whether or not the paper size and type settings applied for the bypass tray are those specified using the control panel, printer driver, or print command.

Default: **[Driver/Command]**

- Driver/Command

When the source paper tray is specified for a print job, the paper settings specified using the printer driver or by print command are applied, regardless of any settings specified using the control panel.

- Machine Setting(s)

The paper settings specified on the printer's control panel are applied to all print jobs. An error may occur if the paper settings specified using the printer driver or by print command do not match those specified using the control panel.

- Machine Settng(s): Any Type

Printing is performed according to the paper size specified using the printer driver or print command and the paper type specified on the machine. Regardless of the type of

paper in the paper tray, you can print properly by specifying a paper type using the printer driver or print command.

- Any Size/Type

If the printer's trays do not contain any paper to match the print job settings, printing can be performed from the bypass tray with the job's settings applied.

- Any Custom Size/Type

If the printer's trays do not contain any paper to match the print job settings but custom paper was specified using the printer driver or by print command, printing can be performed from the bypass tray with the job's settings applied.

Trays 1 to 2

You can specify whether the paper size and type settings applied for Trays 1 to 4 are those specified using the control panel, printer driver, or print command.

Default: [**Machine Setting(s)**]

- Driver/Command
- Machine Setting(s)

5

Tray Switching

You can specify whether or not the printer automatically switches paper trays when paper of the specified size and type is not loaded in the driver-designated tray.

Default: [**Off**]

- On
- Off

Extend Auto Tray Switching

You can set the printer to switch paper trays automatically, regardless of whether the tray is manually or automatically selected.

Default: [**Off**]

- On
- Off

PCL Char.Thickness Adjust.

Specify whether or not to thicken the typeface if characters appear blurred when printing through the PCL 5c or PCL6 printer driver.

Default: [**Off**]

- On
- Off

PCL Menu (SP C340DN)

You can set conditions when using PCL for printing.

Orientation

Select the page orientation.

Default: **[Portrait]**

- Portrait
- Landscape

Form Lines

You can specify the number of lines per page from 5 to 128. The default paper size is used when the paper size is not specified in the print data.

Default:

 **Region A** (mainly Europe and Asia)

64

 **Region B** (mainly North America)

60

Font Source

You can specify the location of the default font.

When you select **[RAM]**, you can select only fonts downloaded to the printer RAM.

When you select **[HDD]**, you can select only fonts downloaded to the hard disk.

When you select **[SD Font Download]**, you can select only fonts downloaded to the SD card.

Default: **[Resident]**

- Resident
- RAM
- HDD
- SD
- SD Font Download

Font Number

You can specify the ID of the default font you want to use.

Default: **0**

- 0 to 63 (Resident)
- 1 to X (Download; "X" is the number of downloaded fonts)

Point Size

You can specify the point size you want to use for the default font between 4.00 to 999.75 in 0.25 increments. This setting is effective only for a variable-space font.

Default: 12.00 points

Font Pitch

You can specify the number of characters per inch you want to use for the default font between 0.44 to 99.99 in 0.01 increments. This setting is effective only for fixed-space fonts.

Default: 10.00 pitches

Symbol Set

You can specify the character set for the default font.

Default: [PC-8]

Available sets are as follows:

Roman-8, Roman-9, ISO L1, ISO L2, ISO L5, ISO L6, ISO L9, PC-775, PC-8, PC-8 D/N, PC-850, PC-852, PC-858, PC8-TK, PC-1004, Win L1, Win L2, Win L5, Win Baltic, Desktop, PS Text, MS Publ, Math-8, PS Math, Pifont, Legal, ISO 4, ISO 6, ISO 11, ISO 15, ISO 17, ISO 21, ISO 60, ISO 69, Win 3.0, MC Text, UCS-2, PC-864, Arabic-8, Win Arabic, PC-866, PC-866U, ISO Cyrillic, Win Cyrillic, PC-851, Greek-8, ISO Greek, PC-8 Greek, Win Greek, PC-862, Hebrew-7, Hebrew-8, ISO Hebrew

Courier Font

You can select the type of courier font.

Default: [Regular]

- Regular
- Dark

Ext. A4 Width

You can specify whether or not to extend the width of the printable area of A4 sheets by reducing side margins.

Default: [Off]

- On
- Off

Append CR to LF

You can specify whether or not to append a CR code to each LF code to print text data clearly.

Default: [Off]

- On
- Off

Resolution

You can specify the print resolution in dots per inch.

Default: **[600dpi Fast]**

- 600dpi Fast
- 600dpi Std.
- 1,200dpi (PCL 6 only)

PS Menu (SP C340DN)

You can set conditions when using PostScript for printing.

Job Timeout

You can specify how long the printer waits before canceling the current job when the job is interrupted while being processed. If you select Use Machine Setting(s), enter a value between 0 to 999. (Default: 0)

Default: **[Use Driver/Command]**

- Use Driver/Command
- Use Machine Settings

Wait Timeout

You can specify how long the printer waits before it denies receiving a job when the printer cannot determine when the job ends. If you select Use Machine Setting(s), enter a value between 0 to 999. (Default: 300)

Default: **[Use Driver/Command]**

- Use Driver/Command
- Use Machine Settings

Paper Selection Method

You can specify how the source tray will be selected by specifying the default value for DeferredMediaSelection in PostScript.

Default: **[Select Paper Tray]**

- Auto Select

The default value for DeferredMediaSelection is "true". The source tray that matches the paper setting specified in a print job will be selected.

- Select Paper Tray

The default value for DeferredMediaSelection is "false". The source tray will be selected according to the media selection of PostScript Language Reference.

Swtchng btwn 1&2 Sided Prnt

You can specify which side of the paper to print on when the PS command is used to perform duplex printing and the "setpagedevice" command is entered.

Default: **[Active]**

- Active
Cancels duplex printing, and prints pages after the "setpagedevice" command has been entered on the front side of paper.
- Inactive
Retains duplex printing, and prints pages after the "setpagedevice" command has been entered on the back side of paper.

Data Format

You can select the data format from Binary Data or TBCP.

This setting is ineffective if a parallel or EtherTalk connection is used.

When binary data is sent from the printer driver when the printer is working with a parallel or USB connection, the print job is canceled.

Default: **[TBCP]**

- Binary Data
- TBCP

When an Ethernet connection is used, the print job is canceled if:

- The printer driver data format is TBCP and the data format selected using the control panel is Binary Data.
- The printer driver data format is binary and the data format selected using the control panel is TBCP.

Resolution

You can specify the resolution.

Default: **[600dpi Fast]**

- 600dpi Fast
- 600dpi Std.
- 1200dpi

Toner Saving

You can specify whether or not to reduce toner consumption when printing. When this setting is enabled, print quality may be degraded.

Default: **[Off]**

- On
- Off

Color Setting

You can specify the RGB setting.

Default: [**Super Fine**]

- None
- Fine
- Super Fine

Color Profile

You can specify the color profile.

Default: [**Auto**]

- Auto
- Presentation
- Solid Color
- Photographic
- User Setting

Process Color Model

You can specify the color model.

Default: [**Color**]

- Color
- Black and White

Orientation Auto Detect

You can specify orientation auto detect.

Default: [**On**]

- On
- Off

Gray Reproduction

You can specify how to print black or gray tones.

Default: [**Black/Gray by K (Black)**]

- Black/Gray by K (Black)
- Black by K (Black)
- CMY + K
- Blk/Gry by K(Blk)-TextOnly
- Black by K (Blk)-Text Only
- Black/Gray by K-Strong UCR

PDF Menu (SP C340DN)

You can set conditions when using PDF for printing.

Change PDF Password

You can set the password for the PDF file printed using PDF Direct Print.

A password can be also set using Web Image Monitor, but in this case the password information is sent through the network. If security is a priority, set the password using this menu from the control panel.

PDF Group Password

This setting is not available on this printer.

Reverse Order Printing

You can set the printer to start printing from the last page of the document. Use this function when prints come out face up in the output tray. This allows a printed document to be assembled in sequential order.

Default: [Off]

- On
- Off

Resolution

You can specify the resolution for the PDF file executing PDF Direct Print.

Default: [600dpi Fast]

- 600dpi Fast
- 600dpi Std.
- 1200dpi

Toner Saving

You can specify whether or not to reduce toner consumption when printing. When this setting is enabled, print quality may be degraded.

Default: [Off]

- On
- Off

Color Setting

You can specify the RGB setting.

Default: [Super Fine]

- None
- Fine
- Super Fine

Color Profile

You can specify the color profile.

Default: **[Auto]**

- Auto
- Presentation
- Solid Color
- Photographic
- User Setting

Process Color Model

You can specify the color model.

Default: **[Color]**

- Color
- Black and White

Orientation Auto Detect

You can specify orientation auto detect for the PDF file executing PDF Direct Print.

Default: **[On]**

- On
- Off

Security Options (SP C340DN)

This describes the parameters that can be set on [Security Options].

Extended Security

Specify whether or not to use the extended security functions. For details about the extended security functions, see Security Guide.

Service Mode Lock

You can specify whether or not to prohibit entering service mode. This setting appears only when the user has logged in as the machine administrator.

Default: **[Off]**

- On
- Off

Firmware Version

You can display the firmware version of the printer.

Network Security Level

You can specify the network security level.

Default: **[Level 0]**

- Level 0
- Level 1
- Level 2
- FIPS 140

Auto Erase Memory Setting

You can specify whether or not to automatically delete the memory. When set to **[On]**, specify the overwrite times. To specify the number of memory overwrites, select **[Random Numbers]**. This setting appears only when the optional hard disk is installed.

Default: **[Off]**

- On

HDDERase

- NSA
- DoD
- Random Numbers

Number of Erase: Between 1 to 9

- Off

Erase All Memory

You can delete all data inside the memory. When deleting memory, specify the overwrite times. To specify the number of memory overwrites, select **[Random Numbers]**. This setting appears only when the optional hard disk is installed.

Default: **[Random Numbers]**

HDDERase

- NSA
- DoD
- Random Numbers

Number of Erase: Between 1 to 9

Extend Auth.Mng.

For details about this function, see Security Guide.

Transfer Log Setting

You can specify whether or not to send log information to the log collection server.

Default: **[Off]**

- On (Only available from the log collection server.)
- Off

Machine Data Encryption

You can encrypt data stored on the hard disk. Select the data to be carried over to the hard disk and not be reset.

- Format All Data
- CarryOver FileSys DataOnly
- Carry Over All Data

Collect Logs

You can specify whether or not to collect job logs, access logs, and eco-friendly logs.

Job Log

Default: [**Inactive**]

- Active
- Inactive

Access Log

Default: [**Inactive**]

- Active
- Inactive

Eco-friendly Logs

Default: [**Inactive**]

- Active
- Inactive

Note

- For details, see Security Guide.

Device Setting Information (SP C340 DN)

xxxxxxxxxx

Host Interface (SP C340DN)

This section describes the parameters that can be set on [Host Interface].

I/O Buffer

You can select the size of the I/O buffer. Normally it is not necessary to change this setting.

Default: [128 KB]

- 128 KB
- 256 KB

I/O Timeout

You can specify how many seconds the printer should wait before ending a print job. If printing operation is frequently interrupted by data from other ports, you can increase the timeout period.

Default: [15 seconds]

- 10 seconds
- 15 seconds
- 20 seconds
- 25 seconds
- 60 seconds

5

Network

You can configure the network settings. For details, see page 90 "Configuration".

Machine IPv4 Address

You can specify whether to set the IPv4 address automatically or manually.

Default: [Auto-Obtain (DHCP)]

Auto-Obtain (DHCP)

When DHCP is set to On, the IPv4 address, subnet mask address, and gateway address cannot be changed. To change them, set DHCP to Off. Contact your administrator for information about the network configuration.

Specify

- IP Add.
Manually specify the IPv4 address.
Default: 11.22.33.44
- Subnet M
Manually specify the subnet mask.
Default: 0.0.0.0
- Gateway
Manually specify the gateway address.
Default: 0.0.0.0

IPv6 Stateless Setting

You can specify whether to enable or disable stateless IPv6 address auto configuration.

Default: [Active]

- Active
- Inactive

DHCPv6 Configuration

You can configure the DHCPv6 settings.

DHCPv6 Setting

You can specify whether or not to enable DHCPv6.

Default: [**Inactive**]

- Active
- Inactive

Operation Mode

You can specify the operation mode for DHCPv6 when [DHCPv6 Config.] is set to [Active].

Default: [**Router Request**]

- Router Request
- Obtain IP Address
- Do not obtain IP Address

DNS Server Address

You can specify how the DNS server address is specified when [DHCPv6 Config.] is set to [Active].

Default: [**Auto-Obtain (DHCPv6)**]

- Auto-Obtain (DHCPv6)
- Specify

Ipssec

This is a security function. For details, contact your administrator.

Default: [**Inactive**]

- Active
- Inactive

Effective Protocol

You can specify the effective protocol.

IPv4

Default: [**Active**]

- Active
- Inactive

IPv6

Default: [Inactive]

- Active
- Inactive

SMB

Default: [Active]

- Active
- Inactive

@Remote Service

Default: [Active]

- Active
- Inactive

Firmware Update (IPv4)

Default: [Active]

- Active
- Inactive

Firmware Update (IPv6)

Default: [Active]

- Active
- Inactive

Ethernet Speed

You can specify the network speed to operate the printer. If a communication error occurs because of compatibility problems with the hub, select a speed suitable for your network environment.

In order to reduce power consumption of network devices, the default Ethernet speed of the printer does not exceed 100BASE-TX (100 Mbps). If you want to communicate using a higher speed, select [Auto Select: Enable 1Gbps] to enable 1000BASE-T (1Gbps) communication.

Default: [Auto Select: Disable 1Gbps]

- Auto Select: Enable 1Gbps
- Auto Select: Disable 1Gbps
- 10Mbps Half Duplex
- 10Mbps Full Duplex
- 100Mbps Half Duplex
- 100Mbps Full Duplex

IEEE802.1X Auth.(Ethernet)

You can specify IEEE 802.1X Ethernet authentication. For details about IEEE 802.1X authentication, see Security Guide.

Default: [Inactive]

- Active
- Inactive

Restr.IEEE802.1X Auth.Def.

You can restore the default IEEE 802.1X setting.

LAN Type

You can select Ethernet or Wireless LAN. This menu appears only when the optional wireless LAN interface board is installed.

If Ethernet and Wireless LAN are both connected, the selected interface has priority.

Default: [Ethernet]

- Ethernet
- Wireless LAN

Permit SSL/TLS Comm.

You can set up encrypted communication for SSL/TLS. If you set to [Ciphertext Only], install the SSL certificate for the printer.

Default: [Ciphertext Priority]

- Ciphertext Only
- Ciphertext Priority
- Ciphertext/Cleartext

Parallel Interface

You can configure the parallel interface settings. This menu appears when the IEEE 1284 interface board is installed.

Parallel Timing

You can specify the parallel interface timing.

Default: [ACK outside]

- ACK inside
- ACK outside
- STB down

Parallel Comm. Speed

You can specify whether or not to use DMA transfer for receiving data.

Default: [High Speed]

- High Speed
- Standard

Selection Signal Status

You can specify the selection signal level of the parallel interface.

Default: [**High**]

- High
- Low

Input Prime

You usually do not need to change this setting.

Default: [**Inactive**]

- Active
- Inactive

Bidirectional Comm.

You can specify whether or not to enable or disable bi-directional communication.

Default: [**On**]

- On
- Off

Wireless LAN Settings

You can configure the wireless LAN settings. This menu appears only when the optional wireless LAN interface board is installed.

Wireless LAN Easy Setup

You can set up wireless LAN automatically using Wi-Fi Protected Setup.

Default: [**Push Button Method**]

- Push Button Method
- PIN Code Method

Communication Mode

You can specify the transmission mode for wireless LAN.

Default: [**Infrastructure Mode**]

- 802.11 Ad hoc
- Infrastructure

SSID Setting

You can specify the SSID settings to distinguish the access point in [Infrastructure] or [802.11 Ad hoc].

The characters that can be used are ASCII 0x20-0x7e (32 bytes).

Ad-hoc Channel

You can specify the channel to use when [802.11 Ad hoc] has been selected. Set the channel that matches the type of the wireless LAN being used.

Default: [11]

- IEEE 802.11b/g Wireless LAN

Frequency range:

2412–2462 MHz (channels 1–11)

- IEEE 802.11a Wireless LAN

Frequency range:

5180–5240 MHz (channels 36, 40, 44, and 48)

- IEEE 802.11n Wireless LAN

Frequency range:

2412–2462 MHz (channels 1–11)

5180–5240 MHz (channels 36, 40, 44, and 48)

Security Method

You can specify whether or not to enable the encryption method and security type when the encryption is enabled.

Default: [Off]

- Off

- WEP

Press [Details], and then enter the WEP key using hexadecimal and ASCII characters.

- WPA

Press [Details], and then select the Authentication Methods.

Select one of the following Authentication Methods:

WPA-PSK, WPA(802.1x), WPA2-PSK, WPA2

- WPA2

Press [Details], and then select the Authentication Method.

When you select WPA2, the Encryption Method is set to CCMP (AES) and cannot be changed.

Select one of the following Authentication Methods:

WPA2-PSK, WPA2

When you select WPA2-PSK, enter a passphrase (from 8 to 63 characters).

Direct Connection Settings

You can specify whether or not to enable the control panel can be used as a DHCP server. When the client on a network starts, the information such as an IP address that is required for network connection is assigned automatically.

Default: **[OFF]**

Configure all the following items to enable this function:

- Device name
Press **[RENAME DEVICE]** on the top right of the screen, and then enter the name of the device connected to the client.
- Connection Password
Enter the password for connecting to a network.
- Display IPv4 Address
- Connection Status

Wireless LAN Signal

You can check the signal strength when using wireless LAN.

Restore Defaults

You can reset the wireless LAN settings to their default.

USB Settings

You can configure the communication parameters for computer-to-printer connection via USB.

USB Speed

Default: **[Auto Select]**

- Auto Select
- Full Speed

Fixed USB Port

Default: **[Off]**

- Level 1
- Level 2
- Off

Note

- For details about how to configure the settings using Web Image Monitor, see Web Image Monitor Help.

Language (SP C340DN)

You can select the display language for the menu. Available languages vary depending on the country of purchase.

[English] (default), [French], [German], [Italian], [Spanish], [Dutch], [Norwegian], [Danish], [Swedish], [Polish], [Portuguese], [Hungarian], [Czech], [Finnish], [Russian]

Extended Features (SP C340DN)

Use Web Image Monitor to configure extended features. For details, see Extended Feature Settings.

Memory Erase Status

You can display the status of remaining data in the memory.

 **Important**

- [Memory Erase Status] appears only when the optional hard disk is installed.

Press the [Menu] key, and then select the setting items using the [▼] or [▲] key.

1. Select [Memory Erase Status] ▶ Press [OK]
2. Check the current memory status ▶ Press [OK]

[Data to erase remaining.] : Data remains inside the memory.

[Currently no data to erase.] : No data remains inside the memory.

[Erasing data...] : Data is being deleted.







Printer Configuration Items List (SP C342DN)

This section provides a list of available setting items in each menu and their defaults.

System Settings (SP C342DN)











The table below shows the list of setting items. For details about their functions, see page 286 "System Settings"

General Features (SP C342DN)

Program/Change/Delete User Text			
Panel Key Sound	Lowest, Low, Medium (default) , High, Off		
Function Priority	Home (default) , Printer, Extended Feature		
Screen Color Setting	Blue-gray (default) , Gray, Blue, Green, Red		
Stop Print at Output Limited	Active, Inactive (default)		
Key Repeat	Off, Normal (default) , Repeat Time: Medium, Repeat Time: Long		
Measurement Unit	Default:   Region A (mainly Europe and Asia)  mm   Region B (mainly North America)  inch  mm		
Check Status/Job List Display Time	On (default) <table border="1" style="float: right; margin-left: 20px;"> <tr> <td>10 to 999 seconds</td> </tr> <tr> <td>Default: "15" second(s)</td> </tr> </table>	10 to 999 seconds	Default: "15" second(s)
	10 to 999 seconds		
Default: "15" second(s)			
Off			
Bypass Print: 64-90 mm	Active, Inactive (default)		
External Keyboard	Off (default) , English, German, Canadian French, Italian, Spanish, Dutch, Portuguese, Polish, Czech, Swedish, Finnish, Hungarian, Norwegian, Danish, Japanese, Simplified Chinese, Traditional Chinese, Russian, Hangul, Catalan, Turkish		

Compatible ID	Active (default) , Inactive
Program/Change USB Device List	

Tray Paper Settings (SP C342DN)

Paper Tray Priority: Printer	Tray 1 (default) , Tray 2, Bypass Tray	
Tray Paper Size: Trays 1–2	<p>For details about available paper sizes, see page 106 "Paper Size Specifications".</p> <p>Default:</p> <p>engb  Region A (mainly Europe and Asia)</p> <p>engb A4 </p> <p>engb  Region B (mainly North America)</p> <p>engb 8 1/2 × 11 </p> <p>ch.kr.tw A4 </p>	
Printer Bypass Paper Size	<p>For details about available paper sizes, see page 106 "Paper Size Specifications".</p> <p>Default:</p> <p>engb  Region A (mainly Europe and Asia)</p> <p>engb A4 </p> <p>engb  Region B (mainly North America)</p> <p>engb 8 1/2 × 11 </p> <p>ch.kr.tw A4 </p>	
Paper Type: Bypass Tray	Paper Type	<p>For details about available paper types, see page 108 "Paper Type Specifications".</p> <p>Default: Plain Paper</p>
	Paper Thickness	<p>For details about available paper thickness, see page 108 "Paper Type Specifications".</p> <p>Default: Plain Paper 66-90g/m²</p>

	Apply 2 sided	For details about available 2-sided setting, see page 108 "Paper Type Specifications". Default: Yes
	Apply Auto Paper Select	Yes, No (default)
Paper Type: Trays 1–2	Paper Type	For details about available paper types, see page 108 "Paper Type Specifications". Default: Plain Paper
	Paper Thickness	For details about available paper thickness, see page 108 "Paper Type Specifications". Default: Plain Paper 66-74g/m²
	Apply 2 sided	For details about available 2-sided setting, see page 108 "Paper Type Specifications". Default: Yes
	Apply Auto Paper Select	Yes, No (default)

Timer Settings (SP C342DN)

Sleep Mode Timer	1 to 60 minutes (in increments of 1 minute) Default:"1" minute(s)	
Low Power Mode Timer	On (default)	1 to 60 minutes (in increments of 1 minute) Default: "1" minute(s)
	Off	
Printer Auto Reset Timer	On (default)	10 to 999 seconds (in increments of 1 seconds) Default: "60" second (s)
	Off	

Set Date		
Set Time		
Auto Logout Timer	On (default)	10 to 999 seconds (in increments of 1 seconds) Default: "180" second (s)
	Off	
Fusing Unit Off Mode (Energy Saving) On/Off	On (default)	Exit Fusing Unit Off Mode <ul style="list-style-type: none"> • On Printing (default) • On Operating Control Panel
		Fusing Unit Off Mode Timer <ul style="list-style-type: none"> • 10 seconds to 240 minutes Default: "10" second (s)
Off		
Weekly Timer Detailed Settings	Daily, Day of the Week	Weekly Timer Code <ul style="list-style-type: none"> • On • Off (default)
		Weekly Timer Schedule <ul style="list-style-type: none"> • Weekly Timer 1-6
		Timer Suspension Period <ul style="list-style-type: none"> • Start Date • End Date
	Inactive (default)	

Interface Settings (SP C342DN)

Network

Machine IPv4 Address	Auto-Obtain (DHCP) (default)	
	Specify	IPv4 address <ul style="list-style-type: none"> • 11.22.33.44 (default)

		Subnet mask <ul style="list-style-type: none"> • 0.0.0.0 (default)
IPv4 Gateway Address		
Machine IPv6 Address	Link-local Address, Manual Configuration Address, DHCPv6 Address, Stateless Address: 1-5	
IPv6 Gateway Address		
IPv6 Stateless Address Autoconfiguration	Active (default) , Inactive	
DHCPv6 Configuration	Active	Operation Mode <ul style="list-style-type: none"> • Router Request (default) • Obtain IP Address • Do not obtain IP Address DNS Server Address <ul style="list-style-type: none"> • Auto-Obtain (DHCPv6) (default) • Specify
	Inactive (default)	
DNS Configuration	Auto-Obtain (DHCP) (default)	
	Specify	DNS Server 1-3 <ul style="list-style-type: none"> • 0.0.0.0 (default)
DDNS Configuration	Active (default) , Inactive	
IPsec	Active, Inactive (default)	
Domain Name	Auto-Obtain (DHCP) (default)	
	Specify	Domain Name
WINS Configuration	On (default)	Primary WINS Server <ul style="list-style-type: none"> • 0.0.0.0 (default) Secondary WINS Server <ul style="list-style-type: none"> • 0.0.0.0 (default) Scope ID
	Off	

Effective Protocol	IPv4	Active (default) , Inactive
	IPv6	Active, Inactive (default)
	SMB	Active (default) , Inactive
	@Remote Service	Active (default) , Inactive
	Firmware Update (IPv4)	Active (default) , Inactive
	Firmware Update (IPv6)	Active (default) , Inactive
SMB Computer Name		
SMB Work Group		
Ethernet Speed	AutoSelct:Enable 1 Gbps, AutoSelct:Disable 1 Gbps (default) , 10Mbps Half Duplex, 10Mbps Full Duplex, 100Mbps Half Duplex, 100Mbps Full Duplex	
LAN Type	Ethernet (default) , Wireless LAN	
Ping Command		
Permit SNMPv3 Communication	Encryption Only, Encryption/Cleartext (default)	
Permit SSL/TLS Communication	Ciphertext Only, Ciphertext Priority (default) , Encryption/Cleartext	
Host Name		
Machine Name		
IEEE 802.1X Authentication for Ethernet	Active, Inactive (default)	
Restore IEEE 802.1X Authentication to Defaults		
USB Speed	Auto Select (default) , Full Speed	

Note

- [LAN Type] is displayed only when the optional Wireless LAN interface board is installed.

Parallel Interface

Parallel Timing	ACK inside, ACK Outside (default) , STB down
Parallel Communication Speed	High Speed (default) , Standard

Selection Signal Status	High (default) , Low
Input Prime	Active, Inactive (default)
Bidirectional Communication	On (default) , Off
Signal Control	Job Acceptance Priority (default) , Printer Priority

Note

- This menu appears only when the optional IEEE 1284 interface board is installed.

Wireless LAN

Communication Mode	802.11 Ad-hoc Mode, Infrastructure Mode (default)	
SSID Setting		
Ad-hoc Channel	11 (default) , 36, 40, 44, 48	
Security Method	Off (default)	
	WEP	WEP (Encryption) Key
	WPA2	WPA2 Authent. Method • WPA2, WPA2-PSK
Wireless LAN Easy Setup	Push Button (default) , Enrollee	
Wireless LAN Signal		
Restore Factory Defaults		

Note

- This menu appears only when the optional wireless LAN interface board is installed.

Print List

Print List

Email Settings (SP C342DN)

SMTP Server	Server Name	
	Use Secure Connection (SSL)	On, Off (default)
	Port No.	1-65535

		Default: 25
	Off (default)	
SMTP Authentication	On	User Name Email Address Password Encryption <ul style="list-style-type: none"> • Auto (default) • On • Off
	Off (default)	
POP before SMTP	On	Wait Time after Authent. <ul style="list-style-type: none"> • 0-10,000 milliseconds (in increments of 1 millisecond) User Name Email Address Password
Reception Protocol	POP3 (default), IMAP4, SMTP	
POP3/IMAP4 Settings	Server Name	
	Encryption	Auto (default), On, Off
Administrator's Email Address		
Email Communication Port	POP3	1-65535 Default: 110
	IMAP4	1-65535 Default: 143
Email Reception Interval	On (default)	2-1440 minutes (in increments of 1 minute) Default: "15" minutes
	Off	
Email Storage in Server	Off (default), All, Errors Only	

Auto Email Notify	On (default), Off
-------------------	-------------------

Administrator Tools (SP C342DN)

Address Book Management	New Program	Names, Auth. Info, Protection, Add to Group
	Change, Delete	
Address Book: Program/Change/Delete Group	New Program	Names, Programmed User/Group, Protection, Add to Group
	Change, Delete	
Address Book: Change Order		
Address Book: Edit Title		
Address Book: Switch Title	Title 1 (default), Title 2, Title 3	
Backup/Restore: User Custom Settings & Address Book	Back Up, Restore, Format, Obtain Memory Device Info	
Auto Delete User in Address Book	On, Off (default)	
Delete All Data in Address Book	xxxxxxxx	
Display/Print Counter	Print Counter List	
Display/Clear/Print Counter per User	Printer Counter	Print List for All Users, Clear for All Users, Print List Per User, Clear Per User
	Printer Counter (2 sided, Combined)	xxxxxxxx
Display/Clear Eco-friendly Counter		
Display/Clear Eco-friendly Counter per User		
Eco-friendly Counter Period/Administrator Message		
Machine action when Limit is reached		

Print Volume Use Limitation: Unit Count Setting		
Print Volum. Use Limit.: Default Limit Value		
Media Slot Use		
User Authentication Management	Off (default) , User Code Authentication, Basic Authentication, Windows Authentication, LDAP Authentication, Integration Server Authentication	
Enhanced Authentication Management		
Administrator Authentication Management		
Program/Change Administrator		
Extended Security		
Program/Change/Delete LDAP Server	Program/Change	Name, Server Name, Search Base, Port Number, Use Secure Connection (SSL), Authentication, Search Conditions
	Delete	
Sleep Mode Entry by Sleep Mode Timer	Enable (default) , Disable	
Service Test Call		
Notify Machine Status		
Service Mode Lock		
Firmware Version		
Network Security Level		
Auto Erase Memory Setting		
Erase All Memory		
Delete All Logs		
Transfer Log Setting		
Unauthorized Copy Prevention Printing: Printer	Unauthorized Copy Prevention Stg.	On, Off (default)

Compulsory Unathd. Copy Preventn.	Driver / Command (default), Driver/Command (Most Settings), Machine Setting(s)
Unauthorized Copy Prevention Type	Data Security for Copying, Unathd. Copy Prev.: Patn. (default)
Data Security for Copying Effect	Text and Background (default), Background Only
Unathd. Copy Prev. of Patrn. Effct.	Text and Background (default), Background Only, Text Only, Reverse Patterns(Text/ Background)
Mask Type for Pattern	None (default), Type 1, Type 2, Type 3, Type 4, Type 5, Type 6, Type 7, Type 8, Type 9, Type 10
Pattern Color	Black (default), Magenta, Cyan
Pattern Density	Default: "3"
Text Selection	Default: [Unauthorized Copy]
Program/Change User Text	
PCL Fonts for Texts	Default: [Arial]
PS Fonts for Texts	Default: [Arial]
xxxxxxx	
Point Size	50-300 points Default: "70" points
Carriage Return Space	50-300 points Default: "70" points
Text Angle	0-359 degrees Default: "30" degrees
Repeat Text	On, On: Rotate 180deg on Return, Off (default)

	Text Position	Top Left, Top Center, Top Right, Center (default) , Bottom Left, Bottom Center, Bottom Right
Fixed USB Port	Off (default) , Level 1, Level 2	
Program/Change/Delete Realm	Program/Change	Realm Name, KDC Server Name, Domain Name
	Delete	
Machine Data Encryption Settings		
Program/Delete Device Certificate		
Device Setting Information: Import Setting (Server)		
Device Setting Information: Run Import (Server)		
Device Setting Information: Export (Memory Storage Device)		
Device Setting Information: Import (Memory Storage Device)		
Energy Server Key to Change Mode	Low Power Mode, Sleep Mode (default)	
Compulsory Security Stamp:Printer	Off (default)	
	On	Date/Time, Printout User Name, Machine ID, Machine IP Address, Adjust Stamp Position
User's Own Customization		
Display Supply Info	Home Screen, Printer Application Screen	On (default) , Off
ECO Night Sensor	Power Off Only (default) , Power Off and On, Inactive	
	Timer to Turn Off	1 minute, 5 minutes, 30 minutes, 60 minutes, 120 minutes (default)
	Timer to Turn On	1 minute (default) , 5 minutes, 30 minutes, 60 minutes, 120 minutes
	Brightness Sensor Level	Brightness Sensor Level to Turn Off

		<ul style="list-style-type: none"> • Default: "0" (0 to 15) Brightness Sensor Level to Turn On • Default: "8" (0 to 15)
Select Switchable Languages	None, Japanese, English, French, German, Italian, Spanish, Dutch, Norwegian, Danish, Swedish, Polish, Portuguese, Hungarian, Czech, Finnish, Simplified Chinese, Traditional Chinese, Russian, Greek, Hangul, Catalan, Turkish, Brazilian Portuguese	
Energy Saver Mode to Disable Print Server	Disable Mode, Enable Mode (default)	
Collect Logs	Job Log, Access Log, Eco-friendly Logs	Active, Inactive (default)
Central Management	xxxxxx	xxxxxx
Ready State After Printing	Control Panel On, Control Panel OFF (Energy Saving) (default)	
Shift to Power Off When Ntwk. Disconnctd.	On, Off (default)	

Printer Features (SP C342DN)

List / Test Print (SP C342DN)

The table below shows the list of setting items. For details about their functions, see page 313 "List / Test Print".

Multiple Lists
Configuration Page
Error Log
Network Summary
Supply Info List
Menu List
Color Sample
PCL Configuration/Font Page

PS Configuration/Font Page
PDF Configuration/Font Page
Hex Dump

Data Management (SP C342DN)



Menu Protect	Level 1, Level 2 (default) , Off	
List / Test Print Lock	On, Off (default)	
Delete All Temporary Print Jobs		
Delete All Stored Print Jobs		
Auto Delete Temporary Print Jobs	On	1-200 hour(s) (in increments of 1 hour) Default: "8" hours
	Off (default)	
Auto Delete Stored Print Jobs	On (default)	1-180 day(s) (in increments of 1 day) Default: "3" days
	Off	
Tray Parameters PCL	Auto Select, Tray1, Tray2, Bypass Tray	
Tray Parameters PS	Tray1, Tray2, Bypass Tray	



5

System (SP C342DN)



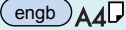
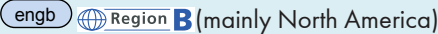
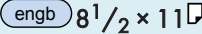

The table below shows the list of setting items. For details about their functions, see page 314 "System".

Print Error Report	On, Off (default)	
Store and Skip Errored Job	On	1-999 page(s) Default: "3" pages
	Off	

Auto Continue	Off (default) , Immediate, 1 minute, 5 minutes, 10 minutes, 15minutes	
Memory Overflow	Do not Print (default) , Error Information	
Auto Cancel Conf. for PDL Error Job	Display, Do not Display (default)	
Auto Cancel for Print Job(s) on Error	On, Off (default)	
Rotate by 180 Degrees	On, Off (default)	
Anti-Humidity	Anti-Humidity Setting	On, Off (default)
	Anti-Humidity Level	Level 1 (Weak) (Default) , Level 2 (Medium), Level 3 (Strong)
Print Compressed Data	On, Off (default)	
Memory Usage	Font Priority, Frame Priority (default)	
Duplex	Off (default) , Long Edge Bind, Short Edge Bind	
Copies	1 to 999 copies (in increments of 1) Default: "1"	
Blank Page Print	On (default), Off	
PCL Character Thickness Adjustment	On, Off (default)	
Spool Printing	On, Off (default)	
Jobs Not Printed As Machine Was Off	Print When Machine On, Do not Print (default)	
Restrict Direct Print Jobs	Off (default) , Automatchly. Store Jobs, Cncl All Direct Prt Jobs	
Switch Initial Screen	Job List (default) , Print Jobs	
Printer Language	Auto (default) , PCL, PS, PDF, XPS	
Default Printer Language	PCL (default) , PS, PDF, XPS	
Sub Paper Size	Auto (default) , Off	
Paper Size	Default:   Region A (mainly Europe and Asia)	

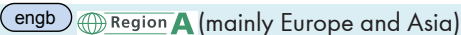
	 A4  Region B (mainly North America)  8 1/2 × 11  A4	
Letterhead Setting	Off, Auto Detect (default) , On (Always)	
Tray Setting Priority	Paper Confirmation for Bypass Tray	Display, Do not Display (default)
	Bypass Tray	Driver/Command (default) , Machine Setting(s), Machine Setting(s): Any Type, Any Size/Type, Any Custom Size/Type
	Trays 1 to 2	Driver/Command, Machine Setting(s) (default)
Edge to Edge Print	On, Off (default)	
Tray Switching	On, Off (default)	
RAM Disk	0 MB, 2 MB, 4 MB (default) , 8 MB, 16 MB	
Extended Auto Tray Switching	On, Off (default)	
I/O Buffer	128 KB (default) , 256 KB	
I/O Timeout	10 seconds, 15 seconds (default) , 20 seconds, 25 seconds, 60 seconds	

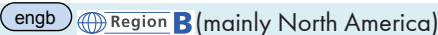
PCL Menu (SP C342DN)

Orientation	Portrait (default) , Landscape
Form Lines	5 to 128 (in increments of 1) Default:  Region A (mainly Europe and Asia)  "64" lines  Region B (mainly North America)  "60" lines  "64" lines

Font Source	Resident (default) , RAM, HDD, SD, SD Font Download
Font Number	0 to 63 (When [Font Source] is [Resident]) or 1 to X (When [Font Source] is other than [Resident]; "X" is the number of fonts) Default: "0" (1 when [Font Source] is other than [Resident])
Point Size	4 to 999.75 (in increments of 0.25) Default: "12.00"
Font Pitch	0.44 to 99.99 (in increments of 0.01) Default: "10.00"
Symbol Set	Roman-8, Roman-9, ISO L1, ISO L2, ISO L5, ISO L6, ISO L9, PC-775, PC-8 (default) , PC-8 D/N, PC-850, PC-852, PC-858, PC8-TK, PC-1004, Win L1, Win L2, Win L5, Win Baltic, Desktop, PS Text, MS Publ, Math-8, PS Math, Pifont, Legal, ISO 4, ISO 6, ISO 11, ISO 15, ISO 17, ISO 21, ISO 60, ISO 69, Win 3.0, MC Text, UCS-2, PC-864, Arabic-8, Win Arabic, PC-866, PC-866U, ISO Cyrillic, Win Cyrillic, PC-851, Greek-8, ISO Greek, PC-8 Greek, Win Greek, PC-862, Hebrew-7, Hebrew-8, ISO Hebrew
Courier Font	Regular (default) , Dark
Extend A4 Width	On, Off (default)
Append CR to LF	On, Off (default)
Resolution	600 dpi (Fast) (default) , 600 dpi (Standard)
Toner Saving	On, Off (default)

PS Menu (SP C342DN)

Job Timeout	Use Driver/Command (default) , Use Machine Settings
Wait Timeout	Use Driver/Command (default) , Use Machine Settings
Paper Selection Method	Auto Select, Select Paper Tray (default)
Switching btwn. 1&2 Sided Print	Active (default) , Inactive
Data Format	Binary Data, TBCP (default)
Resolution	600 dpi (Fast) (default) , 600 dpi (Standard), 1200dpi

Toner Saving	On, Off (default)
Color Setting	Off, Fine, Super Fine (default)
Color Profile	Auto (default) , Presentation, Solid Color, Photographic, User Setting
Process Color Model	Color (default) , Black & White
Orientation Auto Detect	On (default) , Off
Gray Reproduction	Black/Gray by K (Black) (default) , Black by K (Black), CMY + K, Black/Gray by K(Black)-Text Only, Black by K (Black)-Text Only, Black/Gray by K-Strong UCR

PDF Menu (SP C342DN)

5

Change PDF Password	
PDF Group Password	
Reverse Order Printing	On, Off (default)
Resolution	600 dpi (Fast) (default) , 600 dpi (Standard), 1200 dpi
Toner Saving	On, Off (default)
Color Setting	Off, Fine, Super Fine (default)
Color Profile	Auto (default) , Presentation, Solid Color, Photographic, User Setting
Process Color Model	Color (default) , Black & White
Orientation Auto Detect	On (default) , Off

XPS Menu (SP C342DN)

Resolution	600 dpi (Fast) (default) , 600 dpi (Standard)
Toner Saving	On, Off (default)
Color Profile	Auto (default) , Text, Photographic, Graphics
Process Color Model	Color (default) , Black & White

Gray Reproduction	Black/Gray by K (Black) (default) , Black by K (Black), CMY + K, Black/Gray by K(Black)-Text Only, Black by K (Black)-Text Only
-------------------	--

Extended Feature Settings (SP C342DN)

Startup Setting	
Install	
Uninstall	
Extended Feature Info	
Administrator Tools	
Add.Program Startup Setting	
Install Add.Program	
Uninstall Add.Program	
Add.Program Info	





5















Address Book Mangmnt (SP C342DN)

You can configure [Address Book Management] in [Administrator Tools] under [System Settings]. For details, see page 300 "Administrator Tools".

Tray Paper Settings (SP C342DN)

You can configure [Tray Paper Settings] under [System Settings]. For details, see page 287 "Tray Paper Settings".

Paper Tray Priority: Printer	Tray 1 (default) , Tray 2, Bypass Tray
Tray Paper Size: Trays 1–2	For details about available paper sizes, see page 106 "Paper Size Specifications". Default:   Region A (mainly Europe and Asia)  A4   Region B (mainly North America)

	<p> 8¹/₂ × 11 </p> <p> A4 </p>	
Printer Bypass Paper Size	<p>For details about available paper sizes, see page 106 "Paper Size Specifications".</p> <p>Default:</p> <p>  Region A (mainly Europe and Asia)</p> <p> A4 </p> <p>  Region B (mainly North America)</p> <p> 8¹/₂ × 11 </p> <p> A4 </p>	
Paper Type: Bypass Tray	Paper Type	<p>For details about available paper types, see page 108 "Paper Type Specifications".</p> <p>Default: Plain Paper</p>
	Paper Thickness	<p>For details about available paper thickness, see page 108 "Paper Type Specifications".</p> <p>Default: Plain Paper 66-90g/m²</p>
	Apply 2 sided	<p>For details about available 2-sided setting, see page 108 "Paper Type Specifications".</p> <p>Default: Yes</p>
	Apply Auto Paper Select	<p>Yes, No (default)</p>
Paper Type: Trays 1–2	Paper Type	<p>For details about available paper types, see page 108 "Paper Type Specifications".</p> <p>Default: Plain Paper</p>
	Paper Thickness	<p>For details about available paper thickness, see page 108 "Paper Type Specifications".</p> <p>Default: Plain Paper 66-74g/m²</p>

	Apply 2 sided	For details about available 2-sided setting, see page 108 "Paper Type Specifications". Default: Yes
	Apply Auto Paper Select	Yes, No (default)

Edit Home (SP C342DN)

You can add shortcuts to frequently used embedded software applications in the [Home] screen. For details, see page 31 "Customizing the [Home] Screen".

Remote Services (SP C342DN)

You can display the communication screen for @Remote Service. For details, see Security Guide.

Switch Display Language (SP C342DN)

The table below shows the list of setting items. For details about their functions, see page 327 "Switch Display Language".

English (default), French, German, Italian, Spanish, Dutch, Norwegian, Danish, Swedish, Polish, Portuguese, Hungarian, Czech, Finnish, Russian.

Maintenance: Print (SP C342DN)

Plain Paper Setting	Plain Paper (default)	
Replacement Alert	Toner, Waste Toner Bottle, Intermediate Transfer Unit, Fusing Unit.	Notify Sooner, Normal (default) , Notify Later
Supply End Option	Continue Printing (default) , Stop Printing	
Black & White Page Detect	Per Page, Per Job (default)	
Cleaning		
Curl Prevention	Active, Inactive (default)	

Anti-droplet (2 Sided Print)	Active, Inactive (default)
Anti-humidity (Image Dropout Prevention)	Active, Inactive (default)
Black & White Print Priority	On, Off (default)
B & W Low Speed Printing (Thick Paper)	Active, Inactive (default)

Maintenance: Image (SP C342DN)

Color Regist.	For details, see page 440 "Adjusting the Color Registration".	
Color Calibr.	For details, see page 329 "Maintenance: Image". Adjust Auto Density, Print Test Pattern 1, Print Test Pattern 2, Reset Setting	
Adjust Print Position	Print Test Sheet	Paper Trays 1–2, Bypass Tray, Duplex Unit
	Adjust Position	Horizontal: Trays 1-2, Horizontal: Bypass Tray, Horizontal: Back Side <ul style="list-style-type: none"> -15.0 to +15.0 (in 0.34 mm increments) Default: 0.0 Vertical: Trays 1–2, Vertical: Bypass Tray, Vertical: Back Side <ul style="list-style-type: none"> 0 to +9.0 (in 0.3 mm increments) Default: 0.0
4 Color Graphic Mode	Text Priority, Photo Priority (default)	

Function Details of the Printer Configuration Items (SP C342DN)

This section describes the information about the setting items in each menu.

System Settings

This section describes user tools under System Settings menu.

General Features

Program/Change/Delete User Text

You can register text phrases you often use when specifying settings, such as ".com" and "Regards".
You can register up to 40 entries.

Panel Key Sound

You can specify whether or not the beeper (key tone) sounds when a key is pressed.

Default: [Medium]

Function Priority

You can specify the mode to be displayed immediately after the operation switch is turned on, or when System Reset mode is turned on.

Default: [Home]

Screen Color Setting

You can change the screen color.

Default: [Blue-gray]

Key Repeat

You can enable or disable repetition of an operation if a key on the screen or control panel is pressed continuously.

Default: [Normal]

Measurement Unit

You can switch the measurement between [mm] and [inch] when you specify a custom size on the control panel.

Default:

 **Region A** (mainly Europe and Asia)

[mm]

 **Region B** (mainly North America)

[inch]

Check Status/Job List Display Time

You can specify how long to display the System Status and Job List display for.

When the setting is [On], you can specify a display time between 10 and 999 seconds in 1 second increments using the number keys.

Default: [On], "15" second(s)

External Keyboard

You can specify the layout of the external keyboard connected to the USB port.

Default: [Off]

Compatible ID

You can enable or disable the Compatible ID setting.

Default: [Active]

5

Tray Paper Settings

★ Important

- If the specified paper size differs from the actual size of the paper loaded in the paper tray, a misfeed might occur because the correct paper size was not detected.

Paper Tray Priority: Printer

You can specify the tray to supply paper for output.

Default: [Tray 1]

Tray Paper Size: Trays 1–2

You can specify the size of the paper loaded in the paper Trays 1–2. To specify a custom paper size, press [Custom Size] and enter the horizontal and vertical dimensions of the paper.

The paper sizes to be set using the control panel.

For details about available paper sizes, see page 106 "Paper Size Specifications".

Only the installed trays appear on the screen.

Printer Bypass Paper Size

You can specify the size of the paper loaded in the bypass tray. For details about available paper sizes, see page 106 "Paper Size Specifications".

Default: [8¹/₂ × 11 □]

Paper Type: Bypass Tray

You can specify the type of the paper loaded in the bypass tray. For details about available paper types, see page 108 "Paper Type Specifications".

- Paper Type

Default: [Plain Paper]

- Paper Thickness

Default: [Plain Paper 66-90g/m²]

- Apply 2 sided

Default: [Yes]

- Apply Auto Paper Select

Default: [No]

Paper Type: Trays 1–2

You can specify the type of the paper loaded in the paper Trays 1–2. For details about available paper types, see page 108 "Paper Type Specifications".

Only the installed trays appear on the screen.

- Paper Type

Default: [Plain Paper]

- Paper Thickness

Default: [Plain Paper]

- Apply 2 sided

Default: [Yes]

- Apply Auto Paper Select

Default: [No]

5

Note

- In [Plain Paper Setting] in [Maintenance: Print], you can specify the thickness of the plain paper you load. For details, see page 327 "Maintenance: Print".

Timer Settings

Sleep Mode Timer

After a specified period has passed, or the [Energy Saver] key is pressed, the printer enters Sleep Mode in order to conserve energy.

Specify the time to elapse before Sleep Mode.

The time can be set from 1 to 60 minutes, using the number keys.

Default: "1" minute(s)

Depending on which Embedded Software Architecture application is installed on it, the printer might take longer than indicated to enter Sleep Mode.

Printer Auto Reset Timer

You can specify the time to elapse before the printer function is reset.

The time can be set from 10 to 999 seconds, using the number keys.

Default: [On], "60" second(s)

Set Date

You can specify the date for the printer's internal clock using the number keys.

To change between year, month, and day, press [←] and [→].

Set Time

You can specify the time for the printer's internal clock using the number keys.

To change between hours, minutes and seconds, press [←] and [→].

 **Region A** (mainly Europe and Asia)

Enter the time using the 24-hour format (in 1 second increments).

 **Region B** (mainly North America)

Enter the time using the 12-hour format (in 1 second increments).

Auto Logout Timer

You can specify whether or not to automatically log out a user when the user does not operate the printer for a specified period of time after logging in.

The time can be set from 60 to 999 seconds in one second increments, using the number keys.

Default: [On], "180" second(s)

Fusing Unit Off Mode (Energy Saving) On/Off

You can specify whether or not to use Fusing Unit Off mode.

Default: [Off]

- On

Turns on Fusing Unit Off mode. This setting further reduces power consumption, but the printer may take longer to recover from Fusing Unit Off mode.

When you select [On], you can set [Exit Fusing Unit Off Mode] and [Fusing Unit Off Mode Timer].

- Off

Turns off Fusing Unit Off mode.

Exit Fusing Unit Off Mode

You can specify the condition for the printer to exit Fusing Unit Off mode.

Default: [On Printing]

- On Printing

The printer exits Fusing Unit Off mode when printing is performed.

- On Operating Control Panel

The printer exits Fusing Unit Off mode when any key on the control panel is pressed.

Fusing Unit Off Mode Timer

You can specify the period of time the printer waits before entering Fusing Unit Off mode.

The timer is reset if any key on the control panel is pressed or printing is performed.

Default: **[10 seconds]**

The Fusing Unit Off Mode Timer is reset when:

- A print is performed
- A cover is opened when [Exit Fusing Unit Off Mode] is set to [On Printing]
- Any key on the operating panel is pressed when [Exit Fusing Unit Off Mode] is set to [On Operating Control Panel]

Weekly Timer

You can set the timer for the printer to turn off and on the main power or to enter and exit Sleep mode every day or on specified days of the week.

To use Weekly Timer, the date and time of the internal clock must be set using the control panel. For details, see page 288 "Timer Settings".

When Weekly Timer is set to [Daily] or [Day of the Week], the printer does not turn on even if [ECO Night Sensor] is set to [Power Off and On] and the time for turning on the main power specified in [Timer to Turn On] elapses.

Default: **[Inactive]**

- Daily
- Day of the Week
- Inactive

When [Daily] or [Day of the Week] is selected, you can specify the following:

Weekly Timer Code

To configure this setting, administrator authentication must be enabled. For details, see Security Guide.

You can set a password (up to eight digits) for Weekly Timer. Once the password is set, the screen requiring the password is displayed while the printer is turned off or in Sleep mode by Weekly Timer. Enter the password to turn on the printer or recover the printer from Sleep mode.

If you set Weekly Timer Code to [Off], you do not need to enter a password to recover the printer.

Default: **[Off]**

Weekly Timer Schedule

You can specify when Weekly Timer takes effect (up to six settings).

Timer Suspension Period

You can specify the period when the printer does not turn on the main power with the Weekly Timer settings.

During the period specified in [Timer Suspension Period], the Weekly Timer Code is canceled at the time the printer turns on the main power with the Weekly Timer settings. If the printer is turned off during the period specified in [Timer Suspension Period], the Weekly Timer setting to turn on the main power is disabled until the printer is turned on manually.

Interface Settings

Network

Machine IPv4 Address

You can specify the printer's IPv4 network address.

Default: [**Auto-Obtain (DHCP)**]

When you select [Specify], enter the IPv4 address and subnet mask as "xxx.xxx.xxx.xxx" ("x" indicates a number).

When you select [Specify], make sure that the IPv4 address is different from that of other printers on the network.

The physical address (MAC address) also appears.

IPv4 Gateway Address

You can specify the gateway address for the router or host computer used as a gateway.

A gateway is a connection or interchange point between two networks.

Default: [**0.0.0.0**]

Machine IPv6 Address

You can display the printer's IPv6 network address.

- Link-local Address

The printer's specified link-local address appears.

- Manual Configuration Address

The printer's manually configured address appears.

- DHCPv6 Address

The printer's DHCPv6 address appears.

- Stateless Address: 1-5

The specified stateless address appears if [IPv6 Stateless Address Autoconfiguration] is set to [Active].

IPv6 Gateway Address

You can display the printer's IPv6 gateway address.

IPv6 Stateless Address Autoconfiguration

You can specify IPv6 Stateless Address Autoconfiguration.

Default: **[Active]**

DHCPv6 Configuration

You can specify the DHCPv6 setting. If you set to **[Active]**, select "Operation Mode" from **[Router Request]**, **[Obtain IP Address]** or **[Do not obtain IP Address]**, and also select "DNS Server Address" from **[Auto-Obtain (DHCPv6)]** or **[Specify]**.

Default: **[Inactive]**

DNS Configuration

You can configure settings for the DNS server. When you select **[Specify]**, enter the DNS Server IPv4 address as "xxx.xxx.xxx.xxx" ("x" indicates a number).

Default: **[Auto-Obtain (DHCP)]**

DDNS Configuration

You can specify the DDNS settings.

Default: **[Active]**

IPsec

You can specify the printer's IPsec setting. For details about this function, see Security Guide.

Default: **[Inactive]**

Domain Name

You can specify the domain name. When you select **[Specify]**, enter the domain name using up to 63 characters.

Default: **[Auto-Obtain (DHCP)]**

WINS Configuration

You can specify the WINS server settings. If **[On]** is selected, enter the WINS Server IPv4 address as "xxx.xxx.xxx.xxx" ("x" indicates a number). If DHCP is in use, specify a Scope ID. Enter the Scope ID using up to 31 characters.

Do not enter "255.255.255.255" as the primary or secondary WINS server address.

Default: **[On]**

Effective Protocol

You can specify protocols to use in the network.

- IPv4

Default: **[Active]**

- IPv6

Default: **[Inactive]**

- SMB

Default: **[Active]**

- @Remote Service

Default: **[Active]**

- Firmware Update (IPv4)

Default: **[Active]**

- Firmware Update (IPv6)

Default: **[Active]**

SMB Computer Name

You can specify the SMB computer name.

Enter the computer name using up to 15 characters.

"*+ , / ; < > = ? [\] | . and spaces cannot be entered.

Do not set a computer name starting with RNP and rnp.

Only use uppercase letters for alphabets.

SMB Work Group

You can specify the SMB work group.

Enter the computer name using up to 15 characters.

"*+ , / ; < > = ? [\] | . and spaces cannot be entered.

Only use uppercase letters for alphabet.

Ethernet Speed

You can specify the network speed that the printer will use for Ethernet communication. If a communication error occurs because of compatibility problems with the hub, select a speed suitable for your network environment.

To reduce power consumption of network devices, the default Ethernet speed of the printer does not exceed 100BASE-TX (100 Mbps). To communicate using a higher speed, select [Auto Select: Enable 1Gbps] to enable 1000BASE-T (1Gbps) communication.

Default: **[AutoSelct:Disable 1Gbps]**

- AutoSelct:Enable 1Gbps
- AutoSelct:Disable 1Gbps
- 10Mbps Half Duplex
- 10Mbps Full Duplex
- 100Mbps Half Duplex
- 100Mbps Full Duplex

LAN Type

When you have installed the Wireless LAN interface board, you can specify the method of connection. If Ethernet and Wireless LAN are both connected, the selected interface has priority.

Default: **[Ethernet]**

Ping Command

You can check the network connection with ping command using the given IPv4 address.

If you fail to connect to the network, check the following, and then retry the ping command.

- Make sure that "IPv4" in [Effective Protocol] is set to [Active].
- Check that the printer is connected to the network.
- There is a possibility that the same IPv4 address is used for the specified equipment.

Permit SNMPv3 Communication

You can set the encrypted communication of SNMPv3. If you select [Encryption Only], you need to set an encryption password for the printer.

Default: **[Encryption/Cleartext]**

Permit SSL/TLS Communication

You can set the encrypted communication of SSL/TLS. If you select [Ciphertext Only], you need to install the SSL certificate for the printer.

Default: **[Ciphertext Priority]**

Host Name

You can specify the host name. Enter the host name using up to 63 characters.

The following host names are unacceptable:

- a host name starting with or ending with a hyphen
- a host name in which hyphens are used consecutively
- a host name starting with "RNP" or "rnp"

Machine Name

You can specify the printer name. Enter the printer name using up to 31 characters.

IEEE 802.1X Authentication for Ethernet

You can specify the IEEE 802.1X authentication for Ethernet. For details about IEEE 802.1X authentication, see Security Guide.

Default: **[Inactive]**

Restore IEEE 802.1X Authentication to Defaults

You can return the IEEE 802.1X authentication settings to their defaults.

For details about IEEE 802.1X authentication, see Security Guide.

USB Speed

You can specify the communication parameters for computer-to-printer connection via USB.

Default: **[Auto Select]**

Parallel Interface

This menu appears only when the optional IEEE 1284 interface board is installed.

Parallel Timing

You can specify the timing for the control signal of the parallel interface. Normally, you do not need to change this setting.

Default: **[ACK Outside]**

Parallel Communication Speed

You can specify the communication speed for the parallel interface. If the speed is too high, data may not be transferred smoothly. If this happens, change the setting to **[Standard]**.

Default: **[High Speed]**

Selection Signal Status

You can specify the level for the select signal of the parallel interface.

Default: **[High]**

Input Prime

You can specify whether to validate or invalidate the input prime signal upon reception. Normally, you do not need to change this setting.

Default: **[Inactive]**

Bidirectional Communication

You can specify the printer's response mode to a status acquisition request when using a parallel interface. If you experience problems using another manufacturer's printer, set this to **[Off]**. When set to **[Off]**, the bidirectional communication function will be disabled, and the printer driver will not be installed under the Windows Auto Detect function.

Default: **[On]**

Signal Control

You can specify how to handle errors that occur during printing operation or facsimile transmission from a computer.

Default: **[Job Acceptance Priority]**

Wireless LAN

You can configure the wireless LAN settings. This menu appears only when the optional wireless LAN interface board is installed.

Communication Mode

You can specify the communication mode of the wireless LAN.

Default: [**Infrastructure Mode**]

SSID Setting

You can specify the SSID settings to distinguish the access point in [Infrastructure Mode] or [802.11 Ad-hoc Mode]. The characters that can be used are ASCII 0x20-0x7e (32 bytes).

Ad-hoc Channel

You can specify the channel to use when [802.11 Ad-hoc Mode] has been selected. Set the channel that matches the type of the wireless LAN being used.

Default: [**11**]

- IEEE 802.11b/g Wireless LAN
Frequency range:
2412–2462 MHz (channels 1–11)
- IEEE 802.11a Wireless LAN
Frequency range:
5180–5240 MHz (channels 36, 40, 44, and 48)
- IEEE 802.11n Wireless LAN
Frequency range:
2412–2462 MHz (channels 1–11)
5180–5240 MHz (channels 36, 40, 44, and 48)

Security Method

You can specify whether or not to enable an encryption method and security type when encryption is enabled.

Default: [**Off**]

- WEP
Press [WEP (Encryption) Key], and then enter the WEP key using hexadecimal and ASCII characters.
- WPA2
Press [WPA2 Authent. Method], and then select the authentication method.
If you select WPA2, the encryption method is set to CCMP (AES) and cannot be changed.
Select one of the following authentication methods:
WPA2-PSK, WPA2
If you select WPA2-PSK, enter a passphrase (from 8 to 63 characters).
- Off

Wireless LAN Easy Setup

You can set up wireless LAN automatically using Wi-Fi Protected Setup.

Default: [Push Button]

- Push Button
- Enrollee

Wireless LAN Signal

When using infrastructure mode, press [Wireless LAN Signal] to display the printer's radio wave status.

Restore Factory Defaults

You can return the wireless LAN settings to their defaults.

Print List

You can print the printer's current network settings and network information.

5

Email Settings

SMTP Server

You can specify the SMTP server name. Enter the server name using up to 127 characters. Spaces cannot be entered.

If DNS is in use, enter the host name. If DNS is not in use, enter the SMTP server IPv4 address.

Use Secure Connection (SSL)

If you set Use Secure Connection (SSL) to [On], the port number automatically changes to "465".

Default: [Off]

Port No.

Enter the port number between 1 and 65535 using the number keys. The SMTP server shares the same port number with the Direct SMTP server.

Default: [25]

SMTP Authentication

You can specify SMTP authentication (PLAIN, LOGIN, CRAMMD5, DIGEST-MD5). When sending e-mail to an SMTP server, you can enhance the SMTP server security level using authentication that requires entering the user name and password.

If the SMTP server requires authentication, set [SMTP Authentication] to [On], and then specify the user name, password and encryption.

Default: [Off]

- On

User Name

Enter the user name using up to 191 characters. Spaces cannot be entered. Depending on the SMTP server type, "realm" must be specified. Add "@" after the user name, as in "user name@realm".

Email Address

Enter the e-mail address using up to 128 characters.

Password

Enter the password using up to 128 characters. Spaces cannot be entered.

Encryption

- Auto
Use if the authentication method is PLAIN, LOGIN, CRAM-MD5, or DIGEST-MD5.
- On
Use if the authentication method is CRAMMD5 or DIGEST-MD5.
- Off
Use if the authentication method is PLAIN, or LOGIN.

- Off

POP before SMTP

You can specify POP authentication (POP before SMTP). When sending e-mail to an SMTP server, you can enhance the SMTP server security level by connecting to the POP server for authentication.

If you set POP before SMTP to [On], specify the waiting time after authentication, user name, e-mail address, and password. To enable POP server authentication before sending e-mail via the SMTP server, set [POP before SMTP] to [On]. E-mail is sent to the SMTP server after the time specified for [Wait Time after Authent.] has elapsed. If you select [On], enter the server name in POP3/IMAP4 Settings. Also, check the POP3 port number in E-mail Communication Port.

Default: [Off]

- On

Wait Time after Authent.

Specify [Wait Time after Authent.] from zero to 10,000 milliseconds, in increments of one millisecond.

Default: "300" msec.

User Name

Enter the user name using up to 191 characters. Spaces cannot be entered.

Email Address

Enter the e-mail address using up to 128 characters. Spaces cannot be entered.

Password

Enter the password using up to 128 characters. Spaces cannot be entered.

- Off

Reception Protocol

You can specify the Reception Protocol for receiving e-mails.

Default: [POP3]

POP3/IMAP4 Settings

You can specify the POP3/IMAP4 server name for receiving e-mails. The specified POP3/IMAP4 server name is used for [POP before SMTP].

Server Name

If DNS is in use, enter the host name. If DNS is not in use, enter the POP3/IMAP4 or server IPv4 address. Enter the POP3/IMAP4 server name using up to 127 characters. Spaces cannot be entered.

Encryption

You can specify the encryption method.

Default: [Auto]

- Auto

The password is automatically encrypted according to the POP/IMAP server settings.

- On

The password is encrypted.

- Off

The password is not encrypted.

Administrator's Email Address

You can specify the administrator's e-mail address using up to 128 characters.

Email Communication Port

You can specify the port numbers for receiving e-mails. The specified POP3 port number is used for [POP before SMTP]. Enter a port number between 1 and 65535 using the number keys.

POP3

Default: [110]

IMAP4

Default: [143]

Email Reception Interval

You can specify the time interval for receiving e-mails via the POP3 or IMAP4 server. If [On] is selected, the time can be set from 2 to 1440 minutes in increments of one minute.

Default: [On], "15" minute(s)

Email Storage in Server

You can specify whether or not to store received e-mails on the POP3 or IMAP4 server.

Default: [Off]

Auto Email Notify

You can specify whether or not to send an error message to a preset e-mail address when an error occurs in the printer. After changing the setting, turn off the power of the printer briefly, and then turn it on again. For details, see page 343 "Printer Status Notification by E-mail".

Default: [On]

Administrator Tools

To change these settings, contact the administrator. It is recommended that you specify Administrator Authentication before configuring Administrator Tools settings.

Address Book Management

You can add, change or delete information registered in the Address Book. For details about each setting under "Address Book Management", see page 350 "Registering the Address Book".

You can register up to 1,000 users.

You can also register and edit names in the Address Book using Web Image Monitor.

For details about the [Print Volum. Use Limit.] setting under [Auth. Info], see Security Guide.

New Program

You can register names as well as user codes.

Names

You can register a name, key display, registration number, display priority, and title selection.

Auth. Info

You can register a user code, and specify the functions available to each user code. You can also register user names and passwords to be used when accessing an LDAP server. User codes or user names and passwords registered here are also used for the print volume use limitation function.

Protection

You can register a protection code.

Add to Group

You can register a user or group of users registered in the Address Book to a group.

Change

You can change names as well as user codes.

All Users

You can change information registered in the Address Book after selecting the user in [All Users].

User Code

You can change information registered in the Address Book after selecting the user in [User Code].

Delete

You can delete a name from the Address Book.

Address Book: Program/Change/Delete Group

Names registered in the Address Book can be added into a group. You can register up to 100 groups. For details on how to register names to a group, see page 358 "Registering Users to a Group".

You can also register and manage groups in the Address Book using Web Image Monitor.

New Program

You can register groups.

Names

You can register a name, key display, registration number, display priority, and title selection.

Programmed User/Group

You can check the names or groups registered in each group.

Protection

You can register a protection code.

Add to Group

You can put groups registered in the Address Book into a group.

Change

You can change a group from the Address Book.

Delete

You can delete a group from the Address Book.

Address Book: Change Order

You can change the order of registered names. For details about changing the order of the names in the Address Book, see page 353 "Changing order of registered names".

Address Book: Edit Title

You can edit the title to easily find a user.

For details on how to edit titles, see page 354 "Editing titles".

Address Book: Switch Title

You can specify a sorting title for user names from [Title 1] to [Title 3]. For details about sorting titles, see page 352 "Registering User Information".

Default: [Title 1]

Backup/Restore: User Custom Settings & Address Book

Using an SD card, you can backup the printer's Address Book and user settings, and also restore those backup data to the printer.

Restoring data overwrites Address Book data stored on the printer, and clears the counter of each registered user of the printer.

You can also back up and restore the printer's Address Book using Web Image Monitor. For details, see Web Image Monitor Help.

- Back Up

You can back up the printer's Address Book and user settings to an SD card.

- Restore

You can restore the backup copy of the Address Book and user settings from an SD card.

- Format

You can format an SD card.

- Obtain Memory Device Info

You can check the free space and contents of the SD card.

Auto Delete User in Address Book

If the maximum registerable limit for an account is reached and a new account is requested, the oldest account can be deleted and a new account can be registered according to the user settings.

This new account is automatically registered to the Address Book and is not registered to the Address Book manually.

Default: [Off]

Delete All Data in Address Book

You can delete all data in Address Book.

Display/Print Counter

You can view and print the number of prints.

Displays the number of prints for each function (Total, Printer, 2 Sided, Coverage).

- Print Counter List

Prints out a list of the number of prints made under each function.

Display/Clear/Print Counter per User

You can view, print, and reset the number of prints for each user code. For details about printing the counter, see page 357 "Printing or clearing the counter for each user" and page 358 "Printing or clearing the counter for all users".

The number of prints may differ from the counter values shown in Display/Print Counter.

Printer Counter

- Print List for All Users
You can print the counter value for all the users.
- Clear for All Users
You can reset the counter value for all the users.
- Print List Per User
You can print the counter value for each user.
- Clear Per User
You can reset the counter value for each user.

Display/Clear Eco-friendly Counter

For details about this function, see Security Guide.

Display/Clear Eco-friendly Counter per User

For details about this function, see Security Guide.

Eco-friendly Counter Period/Administrator Message

For details about this function, see Security Guide.

Machine Action When Limit is Reached

For details about this function, see Security Guide.

Print Volume Use Limitation: Unit Count Setting

For details about this function, see Security Guide.

Print Volum. Use Limit.: Default Limit Value

For details about this function, see Security Guide.

Media Slot Use

For details about this function, see Security Guide.

User Authentication Management

Default: [Off]

- Off
- User Code Authentication

Using User Code Authentication, you can limit the available functions and supervise their use. When using User Code Authentication, register user codes.

For details about Basic Authentication, Windows Authentication, LDAP Authentication, and Integration Server Authentication, see Security Guide.

Function to Restrict:

Restrict Printer Functions

- Do not Restrict
- Color/Black&White
- Color
- PC Control

Restrict Other Functions

- Browser

Printer Job Authentication

- Entire
- Simple (Limitation)
- Simple (All)
- Basic Authentication
- Windows Authentication
- LDAP Authentication
- Integration Server Authentication

Enhanced Authentication Management

For details about this function, see Security Guide.

Administrator Authentication Management

For details about this function, see Security Guide.

Program/Change Administrator

For details about this function, see Security Guide.

Extended Security

You can specify whether or not to use the extended security functions. For details about the extended security functions, see Security Guide.

Program/Change/Delete LDAP Server

You can program the LDAP server to find up e-mail destinations in the LDAP server Address Book directly.

This function supports LDAP Version 2.0 and 3.0. Digest authentication can only be used under LDAP Ver.3.0. For details about how to program the LDAP Server, see page 365 "Configuring the LDAP Server".

Program/Change

You can program an LDAP server or change a programmed LDAP server.

- Name
- Server Name
- Search Base
- Port Number
- Use Secure Connection (SSL)
- Authentication
- Search Conditions

Delete

You can delete a programmed LDAP server.

Service Test Call

You can make a test call to the @Remote center. This function is available only if the @Remote service is enabled and active. This function is unavailable when [Notify Machine Status] is in use.

Notify Machine Status

You can send notification of the printer's status to the @Remote center. This function is available only if the @Remote service is enabled and active. This function is unavailable when [Service Test Call] is in use.

Service Mode Lock

For details about this function, see Security Guide.

Firmware Version

You can check the version of the software installed in this printer.

Network Security Level

For details about this function, see Security Guide.

Auto Erase Memory Setting

For details about this function, see Security Guide.

Erase All Memory

For details about this function, see Security Guide.

Delete All Logs

For details about this function, see Security Guide.

Transfer Log Setting

For details about this function, see Security Guide.

Unauthorized Copy Prevention Printing: Printer

Unauthorized Copy Prevention Stg.

Specify whether or not to enable the unauthorized copy prevention setting on the printer.

Default: [Off]

- On
- Off

Compulsory Unathd. Copy Preventn.

Select the unauthorized copy prevention setting to prioritize.

Default: [Driver / Command]

- Driver / Command
Prints documents using the settings specified in the printer driver or commands.
- Driver/Command (Most Settings)
Prints the background pattern by using the color and density specified on the printer. For other items, the settings configured in the printer driver or commands are applied when printing is performed.
- Machine Setting(s)
Prints documents using the settings specified on the printer regardless of the printer driver settings.

Unauthorized Copy Prevention Type

Select the Unauthorized Copy Prevention type to use.

Default: [Unathd. Copy Prev.: Patn.]

- Data Security for Copying
If a printed document is copied or scanned using a copier or MFP that is installed with the Copy Data Security unit, images in the document are covered with gray overprint.
- Unathd. Copy Prev.: Patn.
Embeds texts and background images for Unauthorized Copy Prevention for Pattern on the printed document. When a printed document is copied or scanned, a text pattern appears in the background of the document to prevent illegal copying.

Data Security for Copying Effect

Select data security effects for copying that will be applied to a copied or printed document.

Default: [Text and Background]

- Text and Background
- Background Only

Unathd. Copy Prev. of Ptrn. Effct.

Select unauthorized copy prevention effects for patterns that will be applied to the printed document.

Default: [**Text and Background**]

- Text and Background
- Background Only
- Text Only
- Reverse Patterns(Text/Background)

Mask Type for Pattern

Select a pattern to be embedded in the background of a printed document.

Default: [**None**]

The available settings are as follows:

- None, Type 1, Type 2, Type 3, Type 4, Type 5, Type 6, Type 7, Type 8, Type 9, Type 10

5

Pattern Density

Select a density level for the background pattern.

Default: "3"

Text Selection

Enter a text to be embedded in the printed documents to prevent unauthorized copying.

Default: [**Unauthorized Copy**]

The available settings are as follows:

- Do not Specify, Unauthorized Copy, Illegal Copy, Void, Do not copy, Copy Restricted, Copy Prohibited, Controlled Document, Confidential Document, In Confidence, In Strictest Confidence, Confidential, User Name, File Name, Date & Time, User Name + File Name, User Name + Date & Time, File Name + Date & Time, User Name+File Name+Date & Time, User Text 1, User Text 2

"User Name" is the PC login user name.

Program/Change User Text

Register a text to be embedded for unauthorized copy prevention. Once registered, the text to be used can be selected from [Text Selection].

PCL Fonts for Texts

Specify a font type to be used for the copy prevention text when using the PCL.

Default: [**Arial**]

PS Fonts for Texts

Specify a font type to be used for the copy prevention text when using PostScript 3.

Default: **[Arial]**

Point Size

Specify a font size for the copy prevention text by entering a value between 50 and 300 points using the number keys.

Default: **"70"** points

Carriage Return Space

Specify line spaces between text by entering a value from 50 to 300 points using the number keys. This setting is displayed if a value other than [Off] is specified for [Repeat Text].

Default: **"70"** points

Text Angle

Specify a text rotation angle. When a larger number is specified, the text is rotated counterclockwise around the middle of the text string. Specify an angle between 0 to 359 degrees using the number keys.

Default: **"30"** degrees

Repeat Text

The text is printed downward from the upper left corner of the page. If [On: Rotate 180deg on Return] is selected, each line of the text that is separated by a line feed will be rotated by 180 degrees.

Default: **[Off]**

- On
- On: Rotate 180deg on Return
- Off

Text Position

Specify where the text is inserted. This setting is displayed if 0 degrees is specified as the value for [Text Angle] and [Off] is specified as the value for [Repeat Text].

Default: **[Center]**

The available settings are as follows:

- Top Left, Top Center, Top Right, Center, Bottom Left, Bottom Center, Bottom Right

Fixed USB Port

If this function is activated, you can avoid reinstalling the printer driver when connecting a computer pre-installed with the driver to an identical printer model to this printer.

Default: **[Off]**

- Off
- Level 1

It is not necessary to install a new driver when the printer driver of this printer has already been installed on the PC.

- Level 2

For details about this function, consult your administrator.

Program/Change/Delete Realm

You can program the realm to be used for Kerberos authentication. Be sure to set both the realm name and KDC server name when programming a realm. For details about Program/Change/Delete Realm, see page 368 "Configuring the Realm".

Program/Change

You can program a realm or change a programmed realm.

- Realm Name
- KDC Server Name
- Domain Name

Delete

You can delete a programmed realm.

Machine Data Encryption Settings

For details about this function, see Security Guide.

Program/Delete Device Certificate

You can program and delete a self-generated device certificate and also check status of the certificate.

For details about this function, see Security Guide.

Device Setting Information: Import Setting (Server)

For details about this function, see Security Guide.

Device Setting Information: Run Import (Server)

For details about this function, see Security Guide.

Device Setting Information: Export (Memory Storage Device)

For details about this function, see Security Guide.

Device Setting Information: Import (Memory Storage Device)

For details about this function, see Security Guide.

Energy Server Key to Change Mode

xxxxx

Compulsory Security Stamp:Printer

You can specify whether or not to print security stamps on output documents using the printer function. You can adjust where the stamps are printed. Available stamp settings : [Date/Time], [Printout User Name], [Machine ID], [Machine IP Address], [Adjust Stamp Position]

Default: [Off]

User's Own Customization

You can specify whether or not to allow logged-in users to display their own home screen. For details about this function, see Security Guide.

Default: [Prohibit]

Display Supply Info

You can specify whether or not the amount of toner is displayed on the initial screen.

- Home Screen

Default: [On]

- Printer Application Screen

Default: [On]

ECO Night Sensor

The ECO Night Sensor (ambient light sensor) enables the printer to automatically turn off and on the main power when changes in the ambient light level are detected.

You can specify how the printer performs when the ECO Night Sensor detects changes in the ambient light level.

When Weekly Timer is set to [Daily] or [Day of the Week], the printer does not turn on even if [ECO Night Sensor] is set to [Power Off and On] and the time for turning on the main power specified in [Timer to Turn On] elapses.

Default: [Power Off Only]

- Power Off Only

The printer turns off the main power when the ECO Night Sensor detects a low ambient light level.

- Power Off and On

The printer turns off the main power when a decrease in the ambient light level is detected. It turns on the main power when an increase in the ambient light level is detected.

- Inactive

The ECO Night Sensor is disabled.

Timer to Turn Off

You can specify how long the printer waits to turn off the main power when the ECO Night Sensor detects a low ambient light level.

The timer is reset when:

- The sensor detects changes in the ambient light level.
- Any key on the control panel is pressed or printing is performed.
- The main power switch is turned on.

- The printer configuration screen is displayed on the control panel.
- The printer settings are changed using Web Image Monitor.
- The printer settings are imported or exported.
- A program is downloaded.
- The printer resumes Fusing Unit Off mode.
- The printer enters Sleep mode.

Default: **[120 minutes]**

- 1 minute
- 5 minutes
- 30 minutes
- 60 minutes
- 120 minutes

Timer to Turn On

You can specify how long the printer waits before it turns on the main power when the ECO Night Sensor detects an increase in the ambient light level.

The timer is reset when:

- The sensor detects changes in the ambient light level.
- The ECO Night Sensor setting is changed.
- The main power is turned on.
- The printer enters Sleep mode.

Default: **[1 minute]**

- 1 minute
- 5 minutes
- 30 minutes
- 60 minutes
- 120 minutes

Brightness Sensor Level

Brightness Sensor Level to Turn Off

You can set the brightness threshold for the sensor to turn off the main power.

Default: **0**

- 0 (Dark) - 15 (Bright)
 Level 0 (Very dark): Equivalent to a moonlit night
 Level 5 (Dark): Equivalent to a dimly-lit room

Level 7 (Dim): Equivalent to a room at sunset

Level 9 (Bright): Equivalent to a brightly lit room at night

Level 15 (Very bright): Equivalent to a sunlit room

Brightness Sensor Level to Turn On

You can set the brightness threshold for the sensor to turn on the main power.

Default: **8**

- 0 (Dark) - 15 (Bright)

Level 0 (Very dark): Equivalent to a moonlit night

Level 5 (Dark): Equivalent to a dimly-lit room

Level 7 (Dim): Equivalent to a room at sunset

Level 9 (Bright): Equivalent to a brightly lit room at night

Level 15 (Very bright): Equivalent to a sunlit room

You can set a lower value for [Brightness Level to TurnOff] than the one for [Brightness Level to TurnOn].

Brightness levels are based on ambient light. The actual brightness level may differ depending on the environment in which the printer is used.

Select Switchable Languages

You can register up to five languages to be displayed on the control panel. Also, you can change the display language using the display language switch on the [User Tools] screen.

Ready State After Printing

You can specify the state the printer return to after printing documents during Sleep Mode.

Default: [Off]

- On

The printer does not return to Sleep Mode and the [Home] screen appears on the control panel.

- Off

The printer returns to Sleep Mode.

Note

- Unauthorized copy prevention can be specified in Web Image Monitor and in the printer driver. For details about how to configure the settings, see page 144 "Printing Documents that Are Not Authorized for Duplication".

Printer Features

This section describes user tools under Printer Features menu.

List / Test Print

Multiple Lists

You can print the configuration page and error log, network summary and supply list.

Configuration Page

You can print the printer's current configuration values. For details, see page 100 "Interpreting the Configuration Page".

Error Log

You can print error logs listing all errors that occurred during printing. The most recent 30 errors are stored in the error log. If a new error is added when there are 30 errors already stored, the oldest error is deleted. However, if the oldest error belongs to one of the following types of print jobs, it is not deleted. Instead, it will be stored separately in error logs for each job type, up to a maximum of 30 for each log. You can check any of these print jobs for error log information.

- Sample Print
- Locked Print
- Hold Print
- Stored Print

The records of jobs canceled automatically and manually from the control panel can be printed.

Network Summary

You can print the network device status.

Supply Info List

You can print the supply status.

Menu List

You can print a menu list showing the printer's function menus.

Color Demo Page

You can print a color sample.

PCL Configuration / Font Page

You can print the current configuration and installed PCL font list.

PS Configuration / Font Page

You can print the current configuration and installed PostScript font list.

PDF Configuration / Font Page

You can print the current configuration and installed PDF font list.

Hex Dump

You can print in the Hex Dump mode.

Data Management

Menu Protect

You can prevent unauthenticated users from changing the user tools. For details, see Security Guide.

List / Test Print Lock

You can lock the [List / Test Print] items. For details, see Security Guide.

Delete All Temporary Print Jobs

You can delete all Sample Print, Locked Print, Hold Print files temporarily stored in this printer.

Delete All Stored Print Jobs

You can delete all Stored Print files stored in this printer.

Auto Delete Temporary Print Jobs

You can specify whether to automatically delete Sample Print, Locked Print, Hold Print files temporarily stored in this printer. Hold Print files that have valid print time cannot be deleted automatically.

Default: [Off]

If you select [On], you can set up to 200 hours for auto file deleting (Default: "8").

Auto Delete Stored Print Jobs

You can specify whether to automatically delete Stored Print files temporarily stored in this printer.

Default: [On], "3" day(s)

If you select [On], you can set up to 180 days for auto file deleting.

Tray Parameters (PCL)

You can configure settings to change paper tray parameters used for PCL printing. You can specify the settings for the installed trays and the Auto Tray Select function.

Tray Parameters (PS)

You can configure settings to change paper tray parameters used for PostScript printing. You can specify the settings for the installed trays only.

System

Print Error Report

You can specify whether the printer prints an error report when a printer or memory error occurs.

Default: [Off]

Auto Continue

You can specify whether or not the printer automatically continues to print after a system error occurs. For details about how to configure this function, see page 172 "Executing form feed when an error occurs".

Default: [Off]

Store and Skip Errored Job

A document is automatically stored in the printer if a print job is suspended due to an error. Despite this error, the next document can be printed. This function can be used for Normal Print, Sample Print, and Stored Print files. The job type can be specified in the "Job Type:" list of the printer driver. For details, see page 176 "Printing Stored Documents".

Printing of the document that is stored in the printer can be resumed by operating the control panel. For details, see page 183 "Printing of documents stored when print configuration errors occur".

The storage method differs depending on the type of the specified document. For details, see page 174 "Storing jobs with errors automatically".

You can specify the number of pages to check for errors. Enter the number of pages between 1 to 999. (Default: "3")

When two or more pages is specified, the first page of a document may take longer to print.

Default: [Off]

Memory Overflow

You can specify whether or not to print a memory overflow report.

Default: [Do not Print]

Auto Cancel Conf. for PDL Err.Job

You can specify whether or not to cancel printing and display confirmation screen when an error occurs because of restrictions related to the printer language, options, or security settings.

Default: [Do not Display]

Auto Cancel for Prt. Job(s) on Err.

When an error occurs, the printer cancels the print job with an error and the jobs received before the error occurs. For details about setting this function, see page 173 "Automatically canceling printing of jobs with errors".

Default: [Off]

Rotate by 180 Degrees

You can specify whether to rotate the print image 180 degrees relative to the paper orientation.

Default: [Off]

Anti-Humidity

Select whether or not to reduce paper curl and print smearing when printing in a high-humidity environment.

Anti-Humidity Setting

Default: **[Off]**

- On
- Off

Anti-Humidity Level

Default: **[Level 1 (Weak)]**

- Level 1 (Weak)
- Level 2 (Medium)
- Level 3 (Strong)

Print Compressed Data

You can specify whether to uncompress and extract compressed job data before printing it.

The supported compression format is GZIP.

Default: **[Off]**

Memory Usage

You can specify the amount of memory used in Font Priority or Frame Priority, according to paper size or resolution.

Default: **[Frame Priority]**

Duplex

You can specify whether or not to print on both sides of each page.

Default: **[Off]**

Copies

You can specify the number of print sets. This setting is disabled if the number of pages to print has been specified with the printer driver or another command.

The number of copies can be specified from 1 to 999 by increments of one.

Default: "1" copies

Blank Page Print

You can specify whether or not to print blank pages.

Default: **[On]**

Pages that match one of the following conditions are identified as blank.

- There are no images.
- There are images but they are outside the printable area.
- There are only blank characters.

PCL Char.Thickness Adjust.

Specify whether or not to thicken the typeface if characters appear blurred when printing through the PCL 5c or PCL6 printer driver.

Default: [Off]

- On
- Off

Spool Printing

You can specify whether or not to complete spooling before starting to print. Spooling stores a print job temporarily in the printer, and then prints it. This function is available only if the hard disk is installed on the printer.

Default: [Off]

Jobs Not Printed As Machine Was Off

This function is available only if the hard disk is installed on the printer.

You can specify whether or not to print Hold Print files whose specified print time has already passed when the printer's main power switch is turned on.

Default: [Do not Print]

- Print When Machine On

When the printer's main power is turned on, the printer automatically prints all the Hold Print files stored in the printer whose specified print time has already passed.

- Do not Print

If there are Hold Print files whose specified print time has already passed when the printer's power is turned on, the specified print time will be canceled and the files will be deleted depending on the [Auto Delete Temporary Print Jobs] setting. For details, see page 314 "Data Management".

Restrict Direct Print Jobs

This function is available only if the hard disk is installed on the printer.

When a print job is sent to the printer, you can specify whether to store the document in the printer without printing it or cancel printing it. To prevent documents being left on the tray unattended, the documents that have been stored automatically in the printer are not printed unless the control panel is used to print them.

If a document is a Normal Print, Sample Print, or Stored Print file, it can be printed physically. The job type can be specified in the "Job Type:" list of the printer driver. For details, see page 176 "Printing Stored Documents".

If [Automatcly. Store Jobs] is selected, the storage method differs depending on the type of the specified document. For details, see page 172 "Preventing Documents from Being Left Unattended or Taken By Mistake".

Default: [Off]

- Off
- Automatch. Store Jobs
Documents are automatically stored in the printer without being printed regardless of their print settings.
- Cncl All Direct Prt Jobs
Printing is always canceled regardless of the print settings.

Switch Initial Screen

This function is available only if the hard disk is installed on the printer.

You can specify the screen to be displayed when [Printer] is pressed in the Home screen.

Default: [Job List]

- Job List
Displays the list of jobs.
- Print Jobs
Displays the lists of the document stored in the printer and the User IDs.

Printer Language

You can specify the printer language.

Default: [Auto]

Default Printer Language

You can set the default printer language if the printer cannot find the printer language automatically.

Default: [PCL]

Sub Paper Size



You can specify whether A4 or Letter ($8\frac{1}{2} \times 11$) size paper is automatically selected as the default size when the job-specified size is unavailable.

Default: [Auto]

Page Size

You can specify the default paper size.

Default:

-  **Region A** (mainly Europe and Asia)
A4
-  **Region B** (mainly North America)
 $8\frac{1}{2} \times 11$

The paper size you can specify is as follows:

-  **Region A** (mainly Europe and Asia)

A4, A5, A6, B5 JIS, B6 JIS, C5 Env, C6 Env, DL Env, $8\frac{1}{2} \times 14$, $8\frac{1}{2} \times 13\frac{2}{5}$, $8\frac{1}{2} \times 13$, $8\frac{1}{2} \times 11$, $8\frac{1}{4} \times 13$, 8×13 , $7\frac{1}{4} \times 10\frac{1}{2}$, $5\frac{1}{2} \times 8\frac{1}{2}$, $4\frac{1}{8} \times 9\frac{1}{2}$, $3\frac{7}{8} \times 7\frac{1}{2}$, 16K, Custom Size

-  **Region B** (mainly North America)

$8\frac{1}{2} \times 14$, $8\frac{1}{2} \times 13\frac{2}{5}$, $8\frac{1}{2} \times 13$, $8\frac{1}{2} \times 11$, $8\frac{1}{4} \times 13$, 8×13 , $7\frac{1}{4} \times 10\frac{1}{2}$, $5\frac{1}{2} \times 8\frac{1}{2}$, $4\frac{1}{8} \times 9\frac{1}{2}$, $3\frac{7}{8} \times 7\frac{1}{2}$, A4, A5, A6, B5 JIS, B6 JIS, C5 Env, C6 Env, DL Env, 16K, Custom Size

Letterhead Setting

You can specify whether or not to print on paper that has a fixed print side or print direction (letterhead paper, for example). For details, see page 121 "Loading Orientation-Fixed Paper or Two-Sided Paper".

Default: **[Auto Detect]**

- Off

The letterhead printing mode is disabled.

- Auto Detect

You can specify whether or not to print using letterhead mode whenever a page that has a fixed print side or print direction is specified as the first page.

- On (Always)

Print with the letterhead printing mode regularly.

Tray Setting Priority

You can specify whether or not to give priority to the settings specified by the printer driver or commands or to the ones made on the control panel for each tray when the printer receives print data. Only the trays attached to the printer are displayed.

Paper Confirmation for Bypass Tray

You can specify whether or not to display the confirming screen for the paper size, type and feed direction on the control panel when paper is fed from the bypass tray. If **[Display]** is specified, you can check the print settings for the bypass tray before printing starts.

Default: **[Do not Display]**

- Display
- Do not Display

Bypass Tray

Default: **[Driver/Command]**

- Driver/Command

When the source paper tray is specified for a print job, the paper settings specified using the printer driver or by print command are applied, regardless of the settings specified using the control panel.

- Machine Setting(s)

The paper settings specified on the printer's control panel are applied to all print jobs. An error may occur if the paper settings specified using the printer driver or by print command do not match those specified using the control panel.

- Machine Setting(s): Any Type

Printing is performed according to the paper size specified using the printer driver or print command and the paper type specified on the machine. Regardless of the type of paper in the paper tray, you can print properly by specifying a paper type using the printer driver or print command.

- Any Size/Type

If the printer's trays do not contain any paper to match the print job settings, printing can be performed from the bypass tray with the job's settings applied.

- Any Custom Size/Type

If the printer's trays do not contain any paper to match the print job settings but custom paper is specified using the printer driver or by print command, printing can be performed from the bypass tray with the job's settings applied.

Trays 1 to 2

Default: [**Machine Setting(s)**]

- Driver/Command
- Machine Setting(s)

Tray Switching

You can specify whether or not the printer automatically switches paper trays if paper of the specified size and type is not loaded in the driver-specified tray.

Default: [**Off**]

RAM Disk

If the hard disk is not installed for PDF Direct Print, select a value of 2 MB or higher. This function is displayed only if no hard disk is installed.

Default: [**4 MB**]

Extended Auto Tray Switching

You can specify whether or not to automatically switch to a suitable tray when the current tray runs out of paper.

When [**On**] is set, the extended auto tray switching is priority, regardless of the printer driver settings.

Default: [**Off**]

I/O Buffer

You can set the size of the I/O Buffer. Normally it is not necessary to change this setting.

Default: [128 KB]

I/O Timeout

You can set how many seconds the printer should wait before ending a print job. If data from another port usually arrives in the middle of a print job, you should increase this timeout period.

Default: [15 seconds]

PCL Menu

Orientation

You can set the page orientation.

Default: [Portrait]

Form Lines

You can set the number of lines per page.

The number of lines can be specified from 5 to 128 by increments of one.

Default:

-  **Region A** (mainly Europe and Asia)
"64" lines
-  **Region B** (mainly North America)
"60" lines

Font Source

You can set the storage location of the default font.

Default: [Resident]

[RAM], [HDD], [SD], and [SD Font Download] can be selected only when fonts have been downloaded to the printer.

Font Number

You can set the ID of the default font you want to use.

- When [Resident] is selected under [Font Source]:
The font number can be specified from 0 to 63 by increments of one.
Default: "0"
- When [RAM], [HDD], [SD], or [SD Font Download] is selected under [Font Source]:
The font number can be specified from 1 up to number of fonts stored on the printer.
Default: "1"

Point Size

You can set the point size you want to use for the selected font.

The number of point sizes can be specified from 4.00 to 999.75 by increments of 0.25.

This setting is effective only with variable-space fonts.

Default: "12.00" points

Font Pitch

You can set the number of characters per inch for the selected font.

The number of characters per inch can be specified from 0.44 to 99.99 by increments of 0.01.

This setting is effective only with fixed-space fonts.

Default: "10.00" pitches

Symbol Set

You can specify the character set of the selected font. The available settings are as follows:

Roman-8, Roman-9, ISO L1, ISO L2, ISO L5, ISO L6, ISO L9, PC-775, PC-8, PC-8 D/N, PC-850, PC-852, PC-858, PC8-TK, PC-1004, Win L1, Win L2, Win L5, Win Baltic, Desktop, PS Text, MS Publ, Math-8, PS Math, Pifont, Legal, ISO 4, ISO 6, ISO 11, ISO 15, ISO 17, ISO 21, ISO 60, ISO 69, Win 3.0, MC Text, UCS-2, PC-864, Arabic-8, Win Arabic, PC-866, PC-866U, ISO Cyrillic, Win Cyrillic, PC-851, Greek-8, ISO Greek, PC-8 Greek, Win Greek, PC-862, Hebrew-7, Hebrew-8, ISO Hebrew

Default: [PC-8]

Courier Font

You can specify a courier font type.

Default: [Regular]

Extend A4 Width

You can extend the printing area width (when printing on A4 sheet with PCL).

Default: [Off]

When the setting is [On], the width will be $8\frac{1}{2}$ inches.

Append CR to LF

When set to [On], a carriage return will follow each line feed: CR=CR, LF=CR-LF, FF=CR-FF.

Default: [Off]

Resolution

You can set the print resolution in dots per inch.

Default: [600 dpi (Fast)]

PS Menu

Job Timeout

You can specify how long the printer waits before canceling the current job when the job is interrupted while being processed.

Default: [Use Driver/Command]

If you select [Use Machine Settings], enter a value between 0 and 999.

Default: "0"

When set to "0", the current job will not be canceled when interrupted.

Wait Timeout

You can specify how long the printer waits before it cancels receiving the job when the printer cannot detect the end of the job.

Default: [Use Driver/Command]

If you select [Use Machine Settings], enter a value between 0 and 999.

Default: "300"

When set to "0", the print job will not be canceled when the end of the job cannot be detected.

Paper Selection Method

You can specify how the source tray will be selected by specifying the default value for DeferredMediaSelection in PostScript.

Default: [Select Paper Tray]

- Auto Select

The default value for DeferredMediaSelection is "true". The source tray that matches the paper setting specified in a print job will be selected.

- Select Paper Tray

The default value for DeferredMediaSelection is "false". The source tray will be selected according to the media selection of PostScript Language Reference.

Switching between 1&2 Sided Print Functns.

You can specify which side of paper to print on when the PS command is used to perform duplex printing, and the "setpagedevice" command is entered.

Default: [Active]

- Active

Cancels duplex printing, and prints pages after the "setpagedevice" command has been entered on the front side of paper.

- Inactive

Retains duplex printing, and prints pages after the "setpagedevice" command has been entered on the back side of paper.

Data Format

You can specify a data format.

Default: [TBCP]

This setting is not effective when operating the printer with a parallel connection.

When operating the printer with a parallel connection, and also if the binary data is sent from the printer driver, the print job is canceled.

Resolution

You can set the print resolution in dots per inch.

Default: [600 dpi (Fast)]

Toner Saving

You can specify whether or not to reduce toner consumption when printing. When this setting is enabled, print quality may be degraded.

Default: [Off]

Color Setting

You can make an RGB setting.

Default: [Super Fine]

Color Profile

You can set the color profile.

Default: [Auto]

Process Color Model

You can specify the color model.

Default: [Color]

Orientation Auto Detect

You can specify whether or not to automatically detect the print data orientation.

Default: [On]

Gray Reproduction

You can specify how to print black or gray tones.

Default: [Black/Gray by K (Black)]

- Black/Gray by K (Black)
- Black by K (Black)
- CMY + K
- Black/Gray by K(Black)-Text Only
- Black by K (Black)-Text Only
- Black/Gray by K-Strong UCR

PDF Menu

Change PDF Password

You can set the password for the PDF file printed using PDF Direct Print.

[New Password] and [Confirm New Password] appear only when [Current Password] is set.

A password can be also set using Web Image Monitor, but in this case the password information is sent through the network. If security is a priority, set the password using this menu from the control panel.

PDF Group Password

This setting is not available on this printer.

Reverse Order Printing

You can specify whether the printer automatically prints in reverse order.

Default: [Off]

Resolution

You can set the print resolution in dots per inch.

Default: [600 dpi (Fast)]

Toner Saving

Reduces toner consumption when printing. When this setting is enabled, print quality may be degraded.

Default: [Off]

Color Setting

You can make an RGB setting.

Default: [Super Fine]

Color Profile

You can set the color profile.

Default: [Auto]

Process Color Model

Specify the color model.

Default: [Color]

Orientation Auto Detect

You can specify whether or not to automatically detect the print data orientation.

Default: [On]

XPS Menu

Resolution

You can set the print resolution in dots per inch.

Default: [600 dpi Fast]

- 600dpi Fast
- 600dpi Standard

Toner Saving

Reduces toner consumption when printing. When this setting is enabled, print quality may be degraded.

Default: [Off]

Color Profile

You can set the color profile.

Default: [Auto]

Process Color Model

Specify the color model.

Default: [Color]

Gray Reproduction

You can specify how to print black or gray tones.

Default: [Black/Gray by K (Black)]

Extended Feature Settings

You can install, uninstall, and set up Extended Features. For details, see Extended Feature Settings.

Address Book Mangmnt

You can configure [Address Book Management] in [Administrator Tools] under [System Settings]. For details, see page 300 "Administrator Tools".

Tray Paper Settings

You can configure [Tray Paper Settings] under [System Settings]. For details, see page 287 "Tray Paper Settings".

Edit Home

You can add shortcuts to frequently used embedded software applications in the [Home] screen. For details, see page 31 "Customizing the [Home] Screen".

Remote Services

You can display the communication screen for @Remote Service. For details, see Security Guide.

Switch Display Language

Every time you press the display language switch, the display language of the control panel toggles through the languages registered in [Select Switchable Languages] in [Administrator Tools] under [System Settings]. For details about how to change languages, see page 77 "Selecting the Display Language". For details about how to register languages, see page 300 "Administrator Tools".

5

Maintenance: Print

Plain Paper Setting

You can specify the weight of plain paper when [Plain Paper] is selected for [Paper Type] in [Tray Paper Settings] under [System Settings].

The paper weight can be set for each tray separately. For details about the actual paper weight, see page 108 "Paper Type Specifications".

Default: [Plain Paper]

- Plain Paper

Replacement Alert

Use this function to specify the timing to notify user when supplies need to be replaced. Settings can be made separately for Toner, Waste Toner Bottle, Intermediate Transfer Unit, Fusing Unit.

Default: [Normal]

- Notify Sooner
- Normal
- Notify Later

Supply End Option

You can specify whether or not to continue printing after the following components have exceeded their recommended service life.

Default: [Continue Printing]

- Continue Printing
- Stop Printing

Black & White Page Detect

You can specify whether to recognize black-and-white images by page or by document.

The black-and-white recognition function allows the printer to print monochrome images in monochrome mode even if color printing is specified.

Default: **[Per Job]**

- Per Page
- Per Job

Cleaning

You can clear the intermediate transfer unit when white lines appear on printouts.

Curl Prevention

You can control the fuser temperature to prevent paper from curling. Enabling this function may increase the print time and speed for first prints.

Also, the lifetime of the drum unit, intermediate transfer unit, and fusing unit becomes shorter than their normal lifetime.

Default: **[Inactive]**

- Active
- Inactive

Anti-droplet (2 Sided Print)

You can specify whether or not to dry the duplex unit before printing to prevent partial dropouts of printed images on the back sides of two-sided printouts. Enabling this function may increase the print time for duplex printing of first prints. Also, the lifetime of the fusing unit becomes shorter than their normal lifetime.

Default: **[Inactive]**

- Active
- Inactive

Anti-humidity (Image Dropout Prevention)

You can specify whether or not to prevent partial dropouts of printed images when printing in a high humidity environment.

Default: **[Inactive]**

- Active
- Inactive

Black & White Print Priority

You can specify whether or not to reduce consumption of color toner. When this function is enabled, it may take longer to start printing a color page.

Default: [Off]

- On
- Off

B & W Low Speed Printing (Thick Paper)

You can specify whether or not to lower the print speed of black-and-white pages on thick paper if lateral streaks appear on the output. Enabling this setting prevents streaks from appearing on the output by lowering the print speed.

If this function is enabled, the lifetime of the toner and drum unit becomes shorter than their normal lifetime.

Default: [Inactive]

- Active
- Inactive

Maintenance: Image

Color Regist.

You can perform automatic adjustment of color registration. For details, see page 440 "Adjusting the Color Registration".

Color Calibr.

You can adjust the gradation of bright (highlighted parts) and medium areas (middle parts) for printing. For details, see page 441 "Correcting the Color Gradation".

- Adjust Auto Density
You can print the gradation of auto density.
- Print Test Pattern 1
You can print gradation correction sheet 1.
- Print Test Pattern 2
You can print gradation correction sheet 2.
- Reset Setting
You can reset the gradation correction value to default.

Adjust Print Position

You can adjust the starting position of the printing page. For details, see page 445 "Adjusting Printing Position".

Print Test Sheet

You can print the registration test sheet.

Only the installed trays appear on the display panel.

- Paper Trays 1–2
- Bypass Tray
- Duplex Unit

Adjust Position

You can specify the start position for printing on a page.

Only the installed trays appear on the display panel.

- Horizontal: Trays 1-2
- Horizontal: Bypass Tray
- Horizontal: Back Side
- Vertical: Trays 1–2
- Vertical: Bypass Tray
- Vertical: Back Side

4 Color Graphic Mode

You can adjust levels of toner color overlap. If characters or lines blur, setting priority on text may make them clearer. Under normal conditions, set priority on photos.

Default: **[Photo Priority]**

- Text Priority
- Photo Priority

Using a Print Server

This section explains how to configure the printer as a network printer.

Configuring a Print Server

This section explains how to configure the printer as a Windows network printer. The printer is configured to enable use by network clients.

★ Important

- **To change printer properties in the [Printers and Faxes], [Printers], or [Devices and Printers] window, log in to the file server as an administrator or member of the PowerUsers group.**

1. On the [Start] menu, click [Devices and Printers].

For Windows Vista, click [Control Panel], and then click [Hardware and Sound] from [Printer] to display the [Printer] window.

For Windows 8/8.1, click [Settings] on the Charm Bar, and then click [Control Panel]. When the [Control Panel] window appears, click [View devices and printers].

For Windows 10, right-click the [Start] button on the desktop, and then click [Control Panel]. When the [Control Panel] window appears, click [View devices and printers].

2. Right-click the icon of the printer you have added, and then click [Printer properties].

The printer properties appear.

For Windows Vista, right-click the icon of the printer you have added, click [Run as administrator], and then click [Properties].

For Windows 8/8.1/10, right-click the icon of the printer you have added to select the printer, and then click [Printer properties].

3. On the [Sharing] tab, click [Share this printer].

4. To share the printer with users of a different version of Windows, click [Additional Drivers...].

If you have installed an alternative driver by selecting [Shared] during the printer driver installation, this step can be ignored.

5. Click [OK], and then close the printer properties.

Monitoring and Configuring the Printer

This section explains how to monitor and configure the printer.

Using Web Image Monitor

★ Important

- You cannot configure the printer settings using Web Image Monitor from a computer connected to the USB device server's network. Be sure to access Web Image Monitor from the printer's network.

Using Web Image Monitor, you can check the printer status and change settings.

Available operations

The following operations can be remotely performed using Web Image Monitor from a client computer.

- Displaying printer status or settings
- Checking the print job status or history
- Interrupting currently printing jobs
- Resetting the printer
- Managing the Address Book
- Configuring printer settings
- Configuring network protocol settings
- Configuring security settings

Configuring the printer

To perform the operations from Web Image Monitor, TCP/IP is required. After the printer is configured to use TCP/IP, operations from Web Image Monitor become available.

Recommended Web browser

- Windows:
 - Internet Explorer 6.0 or higher
 - Firefox 10 and 15 or higher
 - Google Chrome 19 or higher
- Mac OS:
 - Safari 3.0 or higher
 - Firefox 10 and 15 or higher
 - Google Chrome 19 or higher

Web Image Monitor supports screen reader software. We recommend JAWS 7.0 or a later version.

Note

- Display and operation problems may occur if you do not enable JavaScript and cookies, or if you are using a non-recommended Web browser.
- If you are using a proxy server, change the Web browser settings. Contact your administrator for information about the settings.
- We recommend using Web Image Monitor in the same network.
- If the printer is firewall-protected, it cannot be accessed from computers outside the firewall.
- If the printer under DHCP is used, the IP address may be changed automatically by the DHCP server settings. Enable DDNS setting on the printer, and then connect using the printer's host name. Alternatively, set a static IP address to the DHCP server.
- If the HTTP port is disabled, a connection to the printer using the printer's URL cannot be established. SSL settings must be enabled on this printer. For details, contact your network administrator.
- If Firefox is used, fonts and colors may be different, or tables may not appear properly configured.
- When using a host name under Windows Server 2003/2003 R2/2008/2008 R2/2012/2012 R2 with IPv6 protocol, perform host name resolution using an external DNS server. The host file cannot be used.
- To use JAWS 7.0 under Web Image Monitor, you must be running Windows and Internet Explorer 6.0 or a later version.
- If you are using Internet Explorer 8.0 or higher, downloading will be slower than with other browsers. To download faster with Internet Explorer 8.0 or higher, open the browser's [Internet Options] menu and register the printer's URL as a trusted site, and then disable SmartScreen filter for trusted sites. For details about these settings, see the Internet Explorer Help files.
- You can access Web Image Monitor more quickly by registering the printer's URL as a bookmark. Note that the URL you register must be the URL of the top page, which is the page that appears before login. If you register the URL of a page that appears after login, Web Image Monitor will not open properly from the bookmark.
- If user authentication is activated, you must enter your login user name and password to use Web Image Monitor. For Details, see page 333 "Displaying the top page".
- When you configure settings using Web Image Monitor, do not log in from the control panel. The settings you have configured using Web Image Monitor may become invalid.

Displaying the top page

There are two modes available with Web Image Monitor: guest mode and administrator mode.

Displayed items may differ depending on the printer type.

Guest mode

This mode requires no login to enter.

In the guest mode, the printer status, settings, and print job status can be viewed, but the printer settings cannot be changed.

Administrator mode

This mode requires an administrator login to enter.

In the administrator mode, you can configure various printer settings.

★ Important

- When entering an IPv4 address, do not begin segments with zeros. For example: If the address is "192.168.001.010", you must enter it as "192.168.1.10".

1. Start your Web browser.

2. Enter "http://(printer's IP address or host name)/" in your Web browser's address bar.

The top page of Web Image Monitor appears.

If the printer's host name has been registered on the DNS or WINS server, you can enter it.

When setting SSL, a protocol for encrypted communication, under the environment in which server authentication is issued, enter "https://(printer's IP address or host name)/".

3. To log in to Web Image Monitor in the administrator mode, click [Login] on the top page.

The window for entering the login user name and password appears.

4. Enter your login user name and password, and then click [Login].

For details about the login user name and password, contact your administrator.

Depending on the configuration of your Web browser, the login user name and password might be saved. If you do not want to save them, configure your Web browser's settings so that this information is not saved.

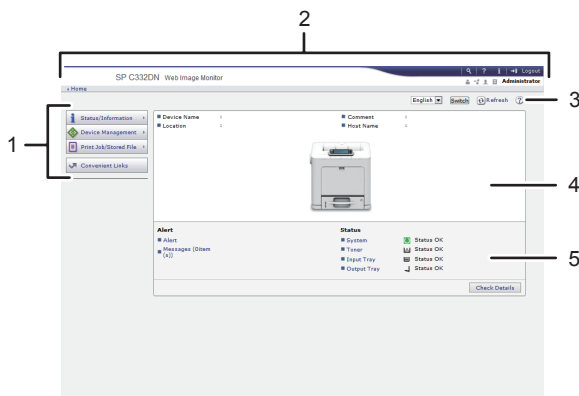

CZV305



1. Menu area

Displays the content of a selected menu item.

2. Header area

Displays the dialog box for switching to the user mode and administrator mode and the menu for each mode. Also displays the link to Help and dialog box for keyword search.

3. Refresh/Help

 (Refresh): Click  at the upper right in the work area to update the printer information. Click the Web browser's [Refresh] button to refresh the entire browser screen.

 (Help): Use Help to view or download Help file contents.

4. Basic Information area

Displays the basic information of the printer.

5. Work area

Displays the contents of the item selected in the menu area.

List of setting items

The following tables show Web Image Monitor items that can be viewed or modified on a Web browser depending on the selected mode.

Status/Information

- Device Info

Menu	Guest mode	Administrator mode
Functions	Read	Read
System	Read	Read
Version	Read	Read
Printer Language	Read	Read

- Status

Menu	Guest mode	Administrator mode
Alert	Read	Read
Messages	Read	Read
Status	Read	Read
Toner	Read	Read

Menu	Guest mode	Administrator mode
Input Tray	Read	Read
Output Tray	Read	Read

- Supplies

Menu	Guest mode	Administrator mode
Toner	Read	Read
Others	Read	Read

- Counter

Menu	Guest mode	Administrator mode
Total	Read	Read
Printer	Read	Read
Coverage	Read	Read
Other Function(s)	Read	Read

- Counter per User

Guest mode	Administrator mode
None	Read/Modify

- Display Eco-friendly Counter

Menu	Guest mode	Administrator mode
Eco-friendly Counter	None	Read/Modify

- Job

Menu	Guest mode	Administrator mode
Job List	Read	Read/Modify
Printer	Read	Read

Note

- [Display Eco-friendly Counter] is displayed only SP C342DN.

Device Management

- Configuration

Device Settings

Menu	Guest mode	Administrator mode
System	Read	Read/Modify
Function Priority	Read	Read/Modify
Paper	Read	Read/Modify
User Paper Type	Read	Read/Modify
Date/Time	Read	Read/Modify
Timer	Read	Read/Modify
Logs	None	Read/Modify
Download Logs	None	Read/Modify
Email	Read	Read/Modify
Auto Email Notification	None	Read/Modify
On-demand Email Notification	None	Read/Modify
User Authentication Management	None	Read/Modify
Administrator Authentication Management	None	Read/Modify
Program/Change Administrator	None	Read/Modify
Print Volume Use Limitation	None	Read/Modify
LDAP Server	None	Read/Modify
Firmware Update	None	Read/Modify
Kerberos Authentication	None	Read/Modify
Device Setting Information: Import Setting (Server)	None	Read/Modify

Menu	Guest mode	Administrator mode
Import Test	None	Read/Modify
Import/Export Device Setting Information	None	Read/Modify
Eco-friendly Counter Period/Administrator Message	Read	Read/Modify
Compulsory Security Stamp	None	Read/Modify
Unauthorized Copy Prevention: Printer	Read	Read/Modify
Program/Change USB Device List	Read	Read/Modify

 **Note**

- [Print Volume Use Limitation] can be read and modified only when User Authentication is activated.
- [Logs] and [Download Logs] are displayed only for SP C340DN.
- [Function Priority], [Eco-friendly Counter Period/Administrator Message], and [Compulsory Security Stamp] are displayed only for SP C342DN.

Printer

Menu	Guest mode	Administrator mode
Basic Settings	Read	Read/Modify
Tray Parameters (PCL)	None	Read/Modify
Tray Parameters (PS)	None	Read/Modify
PDF Group Password	None	Modify
PDF Fixed Password	None	Modify
PDF Temporary Password	Read/Modify	None
Virtual Printer Settings	Read	Read/Modify

Menu	Guest mode	Administrator mode
Permissions for Printer Language to Operate File System	Read	Read/Modify

Interface

Menu	Guest mode	Administrator mode
Interface Settings	Read	Read/Modify
Wireless LAN Settings	Read	Read/Modify

Network

Menu	Guest mode	Administrator mode
IPv4	Read	Read/Modify
IPv6	Read	Read/Modify
SMB	Read	Read/Modify
SNMP	None	Read/Modify
SNMPv3	None	Read/Modify
SSDP	None	Read/Modify
Bonjour	Read	Read/Modify
AirPrint	Read	Read/Modify
System Log	Read	Read

Security

Menu	Guest mode	Administrator mode
Network Security	None	Read/Modify
Access Control	None	Read/Modify
IPP Authentication	None	Read/Modify
SSL/TLS	None	Read/Modify

Menu	Guest mode	Administrator mode
ssh	Read	Read/Modify
Site Certificate	None	Read/Modify
Device Certificate	None	Read/Modify
IPsec	None	Read/Modify
User Lockout Policy	None	Read/Modify
IEEE 802.1X	None	Read/Modify
Extended Security	Read	Read/Modify

5

@Remote

Menu	Guest mode	Administrator mode
Setup RC Gate	None	Read/Modify
Update RC Gate Firmware	None	Read
RC Gate Proxy Server	None	Read/Modify

Webpage

Menu	Guest mode	Administrator mode
Webpage	Read ^{*1}	Read/Modify

*1 Guest users can download a Help file only.

Extended Feature Settings

Menu	Guest mode	Administrator mode
Startup Setting	None	Read/Modify
Extended Feature Info	None	Read
Install	None	Read/Modify
Uninstall	None	Read/Modify
Administrator Tools	None	Read/Modify

Menu	Guest mode	Administrator mode
Additional Program Startup Setting	None	Read/Modify
Install Additional Program	None	Read/Modify
Uninstall Additional Program	None	Read/Modify
Copy Extended Features	None	Read/Modify
Copy Card Save Data	None	Read/Modify

- Address Book

Guest mode	Administrator mode
None	Read/Modify

- Central Management

Guest mode	Administrator mode
None	Read/Modify

- Reset Printer Job

Guest mode	Administrator mode
None	Modify

- Reset the Machine

Guest mode	Administrator mode
None	Modify

- Device Home Management

Menu	Guest mode	Administrator mode
Edit Icons	Read	Read/Modify
Restore Default Icon Display	None	Modify
Home Screen Settings	Read	Read/Modify

- Screen Monitoring

Guest mode	Administrator mode
None	Modify

Note

- [Device Home Management] and [Screen Monitoring] are displayed only for SP C342DN.

Print job/Stored File

- Printer: Print Jobs

Guest mode	Administrator mode
Read/Modify	Read/Modify

Note

- Some items do not appear depending on the security settings.

Displaying Web Image Monitor Help

When using Help for the first time, click the Help button (? ?) to display the message prompting you to select from displaying Help on-line or downloading Help.

Note

- Click the Help button (?) in the header area again to display the contents of Help.
- Click the Help button (?) in the work area again to display the Help for the setting items in the work area.

Viewing Help on our Web site

You can view the latest Help information.

Downloading and Checking Help

You can download Help to your computer. Using the Help URL, you can specify the path to the local file to view Help without connecting to the Internet.

Downloading Help

1. In the "OS" list, select your operating system.
2. In the "Language" list, select a language.
3. Click [Download].
4. Download Help by following the instructions on the screen.
5. Store the downloaded compressed file in a given location, and then decompress the file.

To create a link for the Help button (? ?), save the downloaded Help files on a Web server.

Linking the URL of the downloaded Help

You can link the URL of the Help file on a computer or Web server to the Help button (? ?).

1. Log in to Web Image Monitor in the administrator mode.
2. Click [Configuration] on the [Device Management] menu.
3. Under "Webpage", click [Webpage].
4. In the "Set Help URL Target" box, enter the URL of the Help file.

If you saved the Help file to "\\Server_A\HELP\EN", enter "file://Server_A/HELP/".

For example, if you saved the file to a Web server, and the URL of the index file is "http:// a.b.c.d/HELP/EN/index.html", enter "http://a.b.c.d/HELP/".

5. Click [OK].
6. "Updating..." appears. Wait about one or two minutes, and then click [OK].

Note

- If you save the Help files on your hard disk, you must access them directly. You cannot link to them using the Help button (? ?).

Printer Status Notification by E-mail

Whenever a paper tray becomes empty or paper is jammed, an alert e-mail is sent to the registered addresses to send notification of the printer status.

For this notification, you can make the e-mail notification settings.

Notification timing and e-mail content can be set.

Important

- Depending on your e-mail application, a phishing warning might appear after you receive an e-mail message. To prevent phishing warnings appearing after you receive e-mail from a specified sender, you must add the sender to the exclusion list of your e-mail application. For details about how to do this, see your e-mail application's Help.

The e-mail notification functions you can set are as follows:

- Auto e-mail notification

The printer status information is automatically sent to the preregistered e-mail address. You must specify in advance the requested information items and an e-mail address to receive the information.

- On-demand e-mail notification

The printer status information is sent as a reply to a request e-mail from the administrator.

The information that can be sent by auto e-mail notification is as follows:

- Call Service
- Out of Toner
- Toner Almost Empty
- Paper Misfeed
- Cover Open
- Out of Paper
- Paper Tray Error
- Output Tray Full
- Unit Connection Error
- Waste Toner Bottle is Full
- Waste Toner Bottle is Almost Full
- File Storage Memory Full Soon
- Device Access Violation
- Replacement Required: Unit
- Replacement Required Soon: Unit
- Toner Almost Empty (Remaining Level Selectable)

1. Log in to Web Image Monitor in administrator mode.

For details, see page 333 "Displaying the top page".

2. Click [Configuration] on the [Device Management] menu.

3. Under "Device Settings", click [Email].

4. Configure the following settings:

- Administrator Email Address: Specify the administrator's e-mail address.
- Items in the Reception column: Make the necessary settings for sending and receiving e-mails.
- Items in the SMTP column: Configure the SMTP server. Check your mailing environment, and then specify the necessary items. You can also perform mail authentication for the SMTP server.
- Items in the POP before SMTP column: Configure the POP server. Check your mailing environment, and then specify the necessary items. You can also perform mail authentication for the POP server.
- Items in the POP3/IMAP4 column: Configure the POP3 or IMAP4 server. Check your mailing environment, and then specify the necessary items.
- Items in the Email Communication Port column: Configure the port to be used for access to the mail server.
- Items in the Email Notification Account column: Specify these items If you want to use e-mail notification.

5. Click [OK].
6. Click [Logout].
7. Quit Web Image Monitor.

Note

- For details about the settings, see Web Image Monitor Help.

Setting the account for e-mail notification

Before you use Auto E-mail Notification or On-demand E-mail Notification, set up an e-mail account to be used for the function. Perform the following configuration task in Web Image Monitor:

1. Log in to Web Image Monitor in administrator mode.

For details, see page 333 "Displaying the top page".

2. Click [Configuration] on the [Device Management] menu.
3. Under "Device Settings", click [Email].
4. Configure the following settings in Email Notification Account:
 - Email Notification E-mail Address: Enter the address using alphanumeric characters. This will appear as the sender (From:) of the e-mail notification. Send requests for e-mail notification to this address.
 - Receive Email Notification: Specify whether or not to use on-demand e-mail notification.
 - Email Notification User Name: Enter the specified user name for the e-mail account in "Email Notification E-mail Address".
 - Email Notification Password: Enter the specified password for the e-mail account in "Email Notification E-mail Address".
5. Click [OK].
6. Click [Logout].
7. Quit Web Image Monitor.

Note

- The user name and e-mail address that is already registered as the e-mail destination cannot be specified as the recipient of e-mail notification.

Mail authentication

You can configure mail authentication to prevent illegal use of the mail server.

SMTP Authentication

Specify SMTP authentication settings.

When an e-mail is sent to the SMTP server, authentication is performed using the SMTP AUTH protocol by prompting the mail originator to enter the user name and password. This prevents illegal use of the SMTP server.

1. Log in to Web Image Monitor in administrator mode.
For details, see page 333 "Displaying the top page".
2. Click [Configuration] on the [Device Management] menu.
3. Under "Device Settings", click [Email].
4. Make the following settings in SMTP column:
 - SMTP Server Name: Enter the IP address or host name of the SMTP server.
 - SMTP Port No.: Enter the port number used when sending e-mail to the SMTP server.
 - Use Secure Connection (SSL): Enable or disable SSL.
 - SMTP Authentication: Enable or disable SMTP authentication.
 - SMTP Auth. Email Address: Enter the e-mail address.
 - SMTP Auth. User Name: Enter the SMTP account name.
 - SMTP Auth. Password: Set or change the password for SMTP AUTH.
 - SMTP Auth. Encryption: Specify whether or not to encrypt the password.
[Auto Select]: If the authentication method is PLAIN, LOGIN, CRAM-MD5, or DIGEST-MD5.
[Active]: If the authentication method is CRAM-MD5 or DIGEST-MD5.
[Inactive]: If the authentication method is PLAIN or LOGIN.
5. Click [OK].
6. Click [Logout].
7. Quit Web Image Monitor.

POP before SMTP Authentication

Specify whether or not log in to the POP3 server before sending an e-mail.

1. Log in to Web Image Monitor in administrator mode.
For details, see page 333 "Displaying the top page".
1. Click [Configuration] on the [Device Management] menu.
2. Under "Device Settings", click [Email].
3. Configure the following settings in POP before SMTP column:
 - POP before SMTP: Enable or disable POP before SMTP.
 - POP Email Address: Enter the e-mail address.
 - POP User Name: Enter the POP account name.
 - POP Password: To set or change the POP password.

- Timeout setting after POP Auth.: Enter the time available before connecting to the SMTP server after logging in to the POP server.
4. Click [OK].
 5. Click [Logout].
 6. Quit Web Image Monitor.

Auto e-mail notification

1. Log in to Web Image Monitor in administrator mode.

For details, see page 333 "Displaying the top page".

2. Click [Configuration] on the [Device Management] menu.

3. Under "Device Settings", click [Auto Email Notification].

The dialog box for configuring notification settings appears.

4. Configure the following settings:

- Notification Message: You can set this according to your needs. For example, you can configure printer's location and the service representative's contact information.
- Items in the Groups to Notify column: E-mail notification addresses can be grouped as required.
- Items in the Select Groups/Items to Notify column: Select groups for each notification type, such as printer status and error.

To configure detailed settings for these items, click [Edit] next to "Detailed Settings of Each Item".

5. Click [OK].

6. Click [Logout].

7. Quit Web Image Monitor.

Note

- For details about the settings, see Web Image Monitor Help.

Contents of Auto e-mail notification

If any of the errors specified in [Auto Email Notification] occur, the printer sends an e-mail with the following subject:

"Device Alert Notification: XXXXX (description of the error that has occurred)"

The body of the e-mail contains the error details and protocol setting information of the printer. Clear the error according to the description.

If any of the following messages appears, contact your service representative:

- Functional Problem: Plotter
- Error: Trays 1–2
- Error: Address Book Data
- SD Card Authentication Failure
- Error: HDD Board
- Error: Ethernet Board
- Error: Parallel Interface
- Error: Wireless LAN Card
- Error: USB
- Error: Printer

When the error is cleared, the printer sends an e-mail with the following subject:

"Device Recovery Report: XXXXX (description of the error that has been cleared)"

5

On-demand e-mail notification

1. Log in to Web Image Monitor in administrator mode.

For details, see page 333 "Displaying the top page".

2. Click [Configuration] on the [Device Management] menu.

3. Under "Device Settings", click [On-demand Email Notification].

The dialog box for configuring notification settings appears.

4. Make the following settings:

- Notification Subject: Enter a text string to be added to the subject line of return e-mails.
- Notification Message: You can set this according to your needs, for example, the printer's location and service representative contact information.
- Restriction to Device Status Info.: Specify whether or not to allow access to information such as the printer settings and status.
- Items in the Receivable Email Address/Domain Name Settings column: Enter an e-mail address or domain name to use for requesting information by e-mail and to receive a return e-mail.

5. Click [OK].

6. Click [Logout].

7. Quit Web Image Monitor.

Note

- For details about the settings, see Web Image Monitor Help.

Format of on-demand e-mail messages

To use "On-Demand E-mail Notification", you need to send a request e-mail with a particular format to the printer.

Using your e-mail software, enter the following:

Format of the request e-mail

Item	Description
To	Enter the specified e-mail address in "Email Notification E-mail Address".
Subject	Enter "requeststatus".
From	Specify a valid e-mail address. The device information will be sent to the address specified here.

Note

- The e-mail message must be within 1 MB.
- The subject is not case sensitive.
- It is not necessary to enter the body text in the request e-mail.
- An e-mail transmission may not be complete if an e-mail is sent immediately after the printer is turned on.

Registering the Address Book

This function is available for SP C342DN only.

This section explains how to register destinations and users to the Address Book.

★ Important

- If you are using SP C340DN, set up the Address Book using Web Image Monitor. For details about Web Image Monitor, see page 332 "Using Web Image Monitor".

Address Book

You can register user information such as user names and user codes to the Address Book.

★ Important

- Address Book data is stored on the hard disk. It can be lost if there is a hard disk failure. The manufacturer is not responsible for any damages resulting in data loss.
- If the Extended Security function is enabled, the printer may prevent general users from registering destination addresses to the Address Book.

You can register and manage the following items to the Address Book:

Names

You can register user names and key displays. This is the basic information required for managing users of the printer.

The screenshot shows a configuration window titled "Names" with an "Exit" button in the top right corner. Below the title bar, there is a label "【00001】". The main area contains three input fields: "Registration No." with the value "00001", "Name" with a dark greyed-out field and a "1/2" label to its right, and "Key Display" with a dark greyed-out field. To the right of the "Name" and "Key Display" fields are up and down arrow buttons.

The screenshot shows a configuration window titled "Names" with an "Exit" button in the top right corner. Below the title bar, there is a label "【00001】". The main area contains four input fields: "Display Priority" with the value "5", "Title 1" with the value "Frequent", "Title 2" with the value "Frequent", and "Title 3" with the value "Frequent". To the right of the "Title 1", "Title 2", and "Title 3" fields are up and down arrow buttons. A "2/2" label is positioned to the right of the "Title 1" field.

Auth. Info

You can register user codes to restrict particular functions to certain users and to monitor the usage of each function. You can also register login user names and login passwords to be used when accessing an LDAP server.

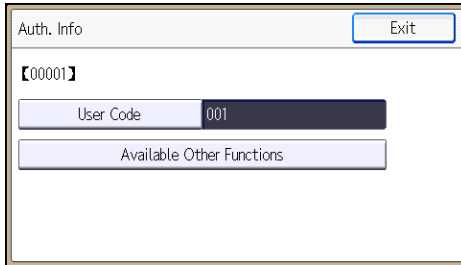

Add to Group

You can add registered users to a group for easier management.

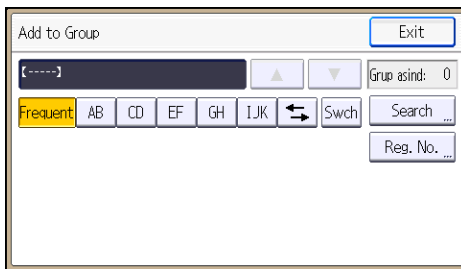

Note

- You can also use Web Image Monitor to register names to the Address Book.
- We recommend you back up the Address Book regularly. For details, see page 351 "Address Book Backup and Restore".
- For details about using Web Image Monitor, see Web Image Monitor Help.

Address Book Backup and Restore

Backing up Address Book data

Follow the procedure below to save a copy of the printer's address book data:

1. **Log in to Web Image Monitor as an administrator.**
For details, see page 333 "Displaying the top page".
2. **In the menu area, click [Address Book] on the [Device Management] menu.**
3. **Click [Maintenance].**

4. Enter the encryption key and click [Backup].

Enter the encryption key that was set when the address book was encrypted. For details, contact your administrator.

Restoring Address Book data

Follow the procedure below to restore previously saved Address Book data to the printer:

1. Log in to Web Image Monitor as an administrator.

For details, see page 333 "Displaying the top page".

2. In the menu area, click [Address Book] on the [Device Management] menu.

3. Click [Maintenance].

4. Click [Restore].

5. Select the file you want to restore by following the on-screen instructions.

6. Click [OK].

7. Confirm the message, and then click [OK].

8. Click [Back].

9. Click [Logout].

Note

- Restoring the previous data will overwrite all Address Book data currently on the printer. Also, it will reset all user counters.

Registering User Information

Register user information including user names.

You can register up to 1,000 names.

Registering names

This section explains how to register names.

1. Press the [User Tools] key, and then display the screen for registering user information.

[Address Book Mangmnt] ▶ [New Program] ▶ [Names]

2. Register user information.

- [Name]
Enter the name ▶ [OK]

- [Title 1], [Title 2] and [Title 3]
Select the key for the classification you want to use ▶ [OK]

The keys you can select are as follows:

- [Frequent]: Adds the user to the page that is displayed first.
- [AB], [CD], [EF], [GH], [IJK], [LMN], [OPQ], [RST], [UVW], [XYZ], [1] to [10]: Adds the user to the list of items in the selected title.

You can select [Frequent] and one more key for each title.

3. Complete the setting.

[Exit] ▶ [OK]

Changing a registered name

5

1. Press the [User Tools] key, and then display the screen for changing information about the Address Book.

[Address Book Mangmnt] ▶ [Change]

2. Select the user whose information you want to change.

[All Users] or [User Code] ▶ Press the name key of the user you want to change

You can search a user by the registered name or user code.

You can also specify a user by pressing [Reg. No.] and entering the registered number.

3. Edit the user information.

[Names] ▶ Select the item you want to change ▶ Change the user information ▶ [OK]

4. Complete the setting.

[Exit] ▶ [OK]

Changing order of registered names

1. Press the [User Tools] key, and then display the [Administrator Tools] screen.

[System Settings] ▶ [Administrator Tools]

2. Change the order of registered users.

[Address Book: Change Order] ▶ [All Users] or [User Code] ▶ Press the name key to be moved
▶ Press the name key of the destination

You can also specify the name key to be moved and the destination by pressing [Reg. No.] and entering the registered numbers.

↓ Note

- You can rearrange the order of the names on the same tab, but names cannot be moved across different tabs. For example, you cannot move a name registered under the [Frequent] tab to the [AB] tab.

Editing titles

1. Press the [User Tools] key, and then display the [Administrator Tools] screen.

[System Settings] ▶ [Administrator Tools]

2. Edit titles.

[Address Book: Edit Title] ▶ Press the title key you want to change ▶ Enter the new name ▶ [OK]
▶ [OK]

Deleting a registered name

1. Press the [User Tools] key, and then display the screen for deleting a user from the Address Book.

[Address Book Mangmnt] ▶ [Delete]

2. Select the user you want to delete.

[All Users] or [User Code] ▶ Press the name key of the user you want to delete

You can search a user by the registered name or user code.

You can also specify a user by pressing [Reg. No.] and entering the registered number.

3. Delete the selected user.

[Yes] ▶ [Exit]

Authentication Information

★ Important

- The functions associated with each user code are the same. If you change or delete user codes, management data and limits associated with that code become invalid.
- Register user codes to restrict and monitor users' performance on the printer.

↓ Note

- You can register up to 1,000 user codes.
- To automatically register a printer driver user code, select [PC Control] under "Printer" in "User Code Authentication". To apply the user code set in User Tools, set the user codes registered to User Tools for the printer driver. For details, see page 300 "Administrator Tools".
- For details about setting user codes for the printer driver, see the printer driver Help.
- For details about how to specify a user code, see Security Guide.

Registering a user code

1. Press the [User Tools] key, and then display the screen for changing information about the Address Book.

[Address Book Mangmnt] ▶ [Change]

2. Select the user whose code you want to register.

[All Users] or [User Code] ▶ Press the name key of the user

You can search a user by the registered name or user code.

You can also specify a user by pressing [Reg. No.] and entering the registered number.

3. Register the user code.

[Auth. Info] ▶ [User Code] ▶ Enter the user code ▶ [OK]

4. Complete the setting.

[Exit] ▶ [OK]

↓ Note

- You can enter a one-to eight-digit user code.
- To register the name, see page 352 "Registering User Information".

Changing a user code

★ Important

- Even if you change a user code, the counter value will not be cleared.

1. Press the [User Tools] key, and then display the screen for changing information about the Address Book.

[Address Book Mangmnt] ▶ [Change]

2. Select the user whose code you want to change.

[All Users] or [User Code] ▶ Press the name key of the user

You can search a user by the registered name or user code.

You can also specify a user by pressing [Reg. No.] and entering the registered number.

3. Change the user code.

[Auth. Info] ▶ [User Code] ▶ Enter the user code ▶ [OK]

4. Complete the setting.

[Exit] ▶ [OK]

Deleting a user code

★ Important

- After clearing the user code, the counter is automatically cleared.

1. Press the [User Tools] key, and then display the screen for changing information about the Address Book.

[Address Book Mangmnt] ▶ [Change]

2. Select the user whose code you want to delete.

[All Users] or [User Code] ▶ Press the name key of the user

You can search a user by the registered name or user code.

You can also specify a user by pressing [Reg. No.] and entering the registered number.

3. Delete the user code.

[Auth. Info] ▶ [User Code] ▶ [Clear] ▶ [OK]

4. Complete the setting.

[Exit] ▶ [OK]

Note

- To delete a name from the Address Book entirely, see page 352 "Registering User Information".

Displaying the counter for each user**1. Press the [User Tools] key, and then display the [Administrator Tools] screen.**

[System Settings] ▶ [Administrator Tools]

2. Display the counter for each user.

[Display/Clear/Print Counter per User] ▶ [Printer Counter] or [Print Volume Use Cntr.]

The counter for each user code is displayed.

[Print Volume Use Cntr.] is displayed only when User Code Authentication is enabled.

3. Check the counter, and then press [Exit].**Printing or clearing the counter for each user****1. Press the [User Tools] key, and then display the [Administrator Tools] screen.**

[System Settings] ▶ [Administrator Tools]

2. Select the user code whose counter you want to print or clear.

[Display/Clear/Print Counter per User] ▶ [Printer Counter] or [Print Volume Use Cntr.] ▶ Select a user code from the left side of the display

You can select multiple user codes at a time.

[Print Volume Use Cntr.] is displayed only when User Code Authentication is enabled.

3. Print or clear the counter of the selected user.

- To print the counter:

Press [Print List] under "Per User" ▶ [Printer] or [Total Prints] ▶ [Start Printing]

- To clear the counter:

Press [Clear] under "Per User" ▶ [Printer], [Prt Volum Use], or [All Counters] ▶ [OK]

4. Press [Exit].

Printing or clearing the counter for all users

1. Press the [User Tools] key, and then display the [Administrator Tools] screen.

[System Settings] ▶ [Administrator Tools]

2. Print or clear the counter for all users.

- To print the counter:

[Display/Clear/Print Counter per User] ▶ [Printer Counter] or [Print Volume Use Cntr.] ▶
Press [Print List] under "All Users" ▶ [Printer] or [Total Prints] ▶ [Start Printing]

- To clear the counter:

[Display/Clear/Print Counter per User] ▶ [Printer Counter] or [Print Volume Use Cntr.] ▶
Press [Clear] under "All Users" ▶ [Printer], [Prt Volum Use], or [All Counters] ▶ [OK]

[Print Volume Use Cntr.] is displayed only when User Code Authentication is enabled.

Registering Users to a Group

You can register users to a group. To add users to a group, the group must be registered first.

★ Important

- You can register up to 500 users to a group.

Registering a group

1. Press the [User Tools] key, and then display the screen for registering groups.

[System Settings] ▶ [Administrator Tools] ▶ [Address Book: Program/Change/Delete Group] ▶
[New Program] ▶ [Names]

2. Register the group information.

- [Name]

Enter the group name ▶ [OK]

- [Title 1], [Title 2] and [Title 3]
Select the key for the classification you want to use ▶ [OK]

The keys you can select are as follows:

- [Frequent]: Adds the user to the page that is displayed first.
- [AB], [CD], [EF], [GH], [IJK], [LMN], [OPQ], [RST], [UVW], [XYZ], [1] to [10]: Adds the group name to the list of items in the selected title.

You can select [Frequent] and one more key for each title.

3. Complete the setting.

[Exit] ▶ [OK]

Registering a user to a group

5

1. Press the [User Tools] key, and then display the screen for changing information about the Address Book.

[Address Book Mangmnt] ▶ [Change]

2. Select the user you want to add to a group.

[All Users] or [User Code] ▶ Press the name key of the user you want to add to a group

You can search a user by the registered name or user code.

You can also specify a user by pressing [Reg. No.] and entering the registered number.

3. Add the selected user to a group.

[Add to Group] ▶ Select the group to which you want to add the user

The group key becomes highlighted, and the user is added to it.

4. Complete the setting.

[Exit] ▶ [OK]

Adding a group to another group

1. Press the [User Tools] key, and then display the screen for registering groups.

[System Settings] ▶ [Administrator Tools] ▶ [Address Book: Program/Change/Delete Group]

2. Select the group you want to add to another group.

[Change] ▶ Press the name key of the group you want to add to another group

You can search a group by the registered name.

You can also specify a group by pressing [Reg. No.] and entering the registered number.

3. Add the selected group to another group.

[Add to Group] ▶ Select the group to which you want to add the selected group

The group key becomes highlighted, and the group is added to it.

4. Complete the setting.

[Exit] ▶ [OK]

Checking users registered in a group

1. Press the [User Tools] key, and then display the screen for registering groups.

[System Settings] ▶ [Administrator Tools] ▶ [Address Book: Program/Change/Delete Group]

2. Select the group for which you want to check the registered users.

[Change] ▶ Press the name key of the group for which you want to check the registered users ▶
[Programmed User/Group]

You can search a group by the registered name.

You can also specify a group by pressing [Reg. No.] and entering the registered number.

3. Check the registered users, and then close the screen.

[Exit] ▶ [OK]

Removing a user from a group

1. Press the [User Tools] key, and then display the screen for changing information about the Address Book.

[Address Book Mangmnt] ▶ [Change]

2. Select the user you want to remove from a group.

[All Users] or [User Code] ▶ Press the name key of the user you want to remove from a group

You can search a user by the registered name or user code.

You can also specify a user by pressing [Reg. No.] and entering the registered number.

3. Remove the selected user from a group.

[Add to Group] ▶ Select the group from which you want to remove the user

The highlighted group key resumes normal display.

4. Complete the setting.

[Exit] ▶ [OK]

Removing a group from another group**1. Press the [User Tools] key, and then display the screen for registering groups.**

[System Settings] ▶ [Administrator Tools] ▶ [Address Book: Program/Change/Delete Group]

2. Select the group you want to remove from another group.

[Change] ▶ Press the name key of the group you want to remove from another group

You can search a group by the registered name.

You can also specify a group by pressing [Reg. No.] and entering the registered number.

3. Select the group from which you want to remove the selected group.

[Add to Group] ▶ Select the group from which you want to remove the selected group

The highlighted group key resumes normal display.

4. Complete the setting.

[Exit] ▶ [OK]

Editing group information

1. Press the [User Tools] key, and then display the screen for registering groups.

[System Settings] ▶ [Administrator Tools] ▶ [Address Book: Program/Change/Delete Group]

2. Select the group for which you want to change the registered information.

[Change] ▶ Press the name key of the group for which you want to change the registered information

You can search a group by the registered name.

You can also specify a group by pressing [Reg. No.] and entering the registered number.

3. Edit the group information.

[Names] ▶ Edit the group information

4. Complete the setting.

[Exit] ▶ [OK]

5

Deleting a group

1. Press the [User Tools] key, and then display the screen for registering groups.

[System Settings] ▶ [Administrator Tools] ▶ [Address Book: Program/Change/Delete Group]

2. Select the group you want to delete.

[Delete] ▶ Press the name key of the group you want to delete

You can search a group by the registered name.

You can also specify a group by pressing [Reg. No.] and entering the registered number.

3. Delete the selected group.

[Yes] ▶ [Exit]

Registering LDAP Authentication

This section explains how to register LDAP Authentication.

LDAP authentication

For each user registered to the Address Book, you can register a login user name and login password to be used when accessing an LDAP server.

To use an LDAP server, you need to program it beforehand. For details, see page 365 "Configuring the LDAP Server".

★ Important

- When [Do not Specify] is selected for [LDAP Authentication], the User Name and Password that you have specified in [Program/Change LDAP Server] of [Administrator Tools] settings are applied. For details, see page 365 "Configuring the LDAP Server".
- If User Authentication is specified, contact your administrator.

1. Press the [User Tools] key, and then display the screen for changing information about the Address Book.

[Address Book Mangmnt] ▶ [Change]

2. Select the user for which you want to set up LDAP Authentication.

[All Users] or [User Code] ▶ Press the name key of the user

You can search a user by the registered name.

You can also specify a user by pressing [Reg. No.] and entering the registered number.

3. Set up LDAP Authentication for the selected user.

[Auth. Info] ▶ [LDAP Authentication] ▶ [Specify Other Auth. Info] ▶ Press [Change] under "Login User Name" ▶ Enter the login user name ▶ [OK] ▶ Press [Change] under "Login Password" ▶ Enter the password ▶ [OK] ▶ Enter the password again to confirm ▶ [OK]

↓ Note

- To register a user, see page 352 "Registering User Information".

Checking Which Functions Are Available

User Authentication can be used to restrict access to the printer by individuals and groups of users according to the login user name and password.

Each individual or group of users can only use the functions made available to them by the administrator according to the user authentication.

Functions Available to Users

Functions available to users are for using the printer's functions, such as printing and storing files.

If the available functions are restricted by user authentication, you can check which functions are available to you by following the procedure below:

- 1. Press the [User Tools] key, and then display the screen for changing information about the Address Book.**

[Address Book Mangmnt] ▶ [Change]

- 2. Check the functions available for a specific user.**

[All Users] or [User Code] ▶ Press the name key of the user for which you want to check available functions ▶ [Auth. Info] ▶ [Available Printer Functions] or [Available Other Functions] ▶ Check the functions available for the selected user ▶ [Exit]

Setting Up LDAP Authentication

This function is available for SP C342DN only.

★ Important

- If you are using SP C340DN, set up the LDAP server using Web Image Monitor. For details about Web Image Monitor, see page 332 "Using Web Image Monitor".

Configuring the LDAP Server

This section explains how to configure the LDAP server settings.

This function supports LDAP version 2.0 and 3.0.

Configure the LDAP server to use LDAP Authentication as a User Authentication method.

For details about LDAP Authentication, see the Security Guide.

5

Registering or changing the LDAP server

To use Kerberos Authentication, a realm must be registered beforehand. For details about registering a realm, see page 368 "Configuring the Realm".

1. Press the [User Tools] key, and then display the [Administrator Tools] screen.

[System Settings] ▶ [Administrator Tools]

2. Select the LDAP server you want to register or change.

[Program/Change/Delete LDAP Server] ▶ [Program/Change] ▶ Select [*Not Programmed] or the LDAP server you want to change

3. Enter the LDAP server name.

[Name] ▶ Enter the LDAP server name ▶ [OK]

4. Enter either the host name or IPv4 address of the LDAP server using up to 128 characters.

[Server Name] ▶ Enter either the host name or IPv4 address ▶ [OK]

5. Select a root folder to start a search.

[Search Base] ▶ Select a root folder to start a search ▶ [OK]

You can search for e-mail addresses registered to a selected folder.

For example, if the search target is the sales department of ABC company, enter "dc=sales department, o=ABC". (In this example, the description is for an active directory. "dc" is for the organization unit, and "o" is for the company.)

Registering a search base may be required depending on your server environment. If it is required, unspecified searches will result in an error.

Check your server environment and enter any required specifications.

6. Specify a port number for communicating with the LDAP server.

[Port Number] ▶ Enter the port number ▶ [OK]

7. Specify whether or not to use SSL when communicating with the LDAP server.

[Use Secure Connection (SSL)] ▶ [On] or [Off] ▶ [OK]

5

To use SSL, the LDAP server must support SSL.

If you set SSL to [On], the port number automatically changes to "636".

If you do not enable SSL, security problems may occur. To enable SSL, you must use the printer's settings. For details, see Security Guide.

8. Select the authentication method for the LDAP server.

- If you do not want to use an authentication method:
[Authentication] ▶ [Off]
- If you want to use an authentication method:
[Authentication] ▶ [On] ▶ [Authentication] ▶ [Kerberos Authentication], [Digest Authentication], or [Cleartext Authentication] ▶ [OK] ▶ Specify the authentication information, such as user name and password, as necessary

The authentication settings must match your server's authentication settings. Check your server settings before configuring this printer.

The administrator account can be used for authentication when you send a search request to the LDAP server. Do not enter the administrator account name and password when using authentication for each individual or search.

- [Kerberos Authentication]
An encrypted password is sent to the KDC server where authentication is performed.
- [Digest Authentication]
An encrypted password is sent to the LDAP server.
Digest Authentication is available with LDAP version 3.0 only.
- [Cleartext Authentication]

An unencrypted password is sent to the LDAP server.

Procedures for setting the user name differ depending on the server environment. Check your server environment before configuring the setting.

Example: Domain Name\User Name, User Name@Domain Name, CN=Name, OU=Department Name, DC=Server Name

You can also connect to the LDAP server using a user name and password stored in the Address Book. For details, see page 363 "LDAP authentication".

- 9. Access the LDAP server to check that a proper connection is established, and then quit the menu.**

[Connection Test] ▶ [Exit] ▶ [OK]

Check that authentication works according to the authentication settings.

If the connection test fails, check your settings and try again.

This function does not check the search conditions or the search base.

- 10. Enter the attributes you want to use when searching for e-mail addresses.**

[Search Conditions] ▶ [Name] or [Email Address] ▶ Enter the attributes you want to use when searching for e-mail addresses ▶ [OK] ▶ [OK] ▶ [OK]

You can enter an attribute as a typical search keyword (up to 64 characters). Using the entered attributes, the function searches the LDAP server's Address Book.

The attribute value may change depending on the server environment. Check that the attribute value matches with your server environment before specifying it.

You can leave items blank, but you cannot leave attributes blank when searching for e-mail addresses from the LDAP server Address Book.

Deleting the registered LDAP server

- 1. Press the [User Tools] key, and then display the [Administrator Tools] screen.**

[System Settings] ▶ [Administrator Tools]

- 2. Select the LDAP server you want to delete.**

[Program/Change/Delete LDAP Server] ▶ [Delete] ▶ Select the LDAP server to be deleted

- 3. Delete the selected LDAP server.**

[Yes] ▶ [Exit]

Configuring the Realm

This section explains how to specify the Realm settings.

A realm is the network area in which Kerberos authentication is used. After confirming the network environment, specify the necessary items.

You can register up to 5 realms.

Registering or changing a Realm

1. Press the [User Tools] key, and then display the [Administrator Tools] screen.

[System Settings] ▶ [Administrator Tools]

2. Select the Realm setting you want to register or change.

[Program/Change/Delete Realm] ▶ [Program/Change] ▶ Select [*Not Programmed] or the realm you want to change

3. Specify the Realm name.

[Realm Name] ▶ Enter the realm name ▶ [OK]

You can enter the host name instead of the Realm name.

4. Specify the KDC server name.

[KDC Server Name] ▶ Enter the KDC server name ▶ [OK]

You can enter the host name or IPv4 address instead of the KDC server name.

5. Specify the domain name.

[Domain Name] ▶ Enter the domain name ▶ [OK]

You can enter the host name instead of the domain name.

6. Complete the setting.

[OK] ▶ [Exit]

Deleting a Realm

1. Press the [User Tools] key, and then display the [Administrator Tools] screen.

[System Settings] ▶ [Administrator Tools]

2. Select the Realm setting you want to delete.

[Program/Change/Delete Realm] ▶ [Delete] ▶ Select the Realm setting you want to delete

3. Delete the selected Realm setting.

[Yes] ▶ [Exit]

6. Troubleshooting

This chapter provides solutions to common problems and it also explains how to correct unwanted print results.

When a Panel Tone Beeps

The following table describes various beep patterns that the printer produces to alert users about printer conditions and the meaning of each beep pattern.

Beep pattern	Meaning	Causes
Single short beep	Panel/screen input accepted.	A control panel key was pressed.
Two long beeps	Printer has warmed up.	When the power is turned on or the printer exits Sleep mode, the printer has fully warmed up and is ready for use.
Single long beep.	Job completed.	A Printer job has finished.
Four long beeps.	Printer initialized.	The screen is changing back to the initial screen after the printer came out of the energy-saving mode or was reset.
Five short beeps repeated five times.	Strong alert	The printer requires user attention because paper has jammed, the toner needs replenishing, or other problems have occurred.





Note

- Beep alerts cannot be muted. If the printer's covers are opened and closed repeatedly within a short space of time during an alert indicating a paper jam or insufficient toner, a beep alert might continue, even after normal status has resumed.
- You can enable or disable beep alerts. For details, see:
 - page 230 "General Settings (SP C340DN)"
 - page 286 "General Features"

When Checking the Indicator Lamps, Status Icons, and Messages on the Control Panel

Indicators

This section describes the indicators displayed when the printer requires the user to remove misfed paper, to add paper, or to perform other procedures.

Indicator	Status
 : Paper Misfeed indicator	Appears when a paper misfeed occurs. For details about removing jammed paper, see page 420 "Removing Jammed Paper".
 : Load Paper indicator	Appears when paper runs out. For details about loading paper, see page 105 "Loading Paper".
 : Add Toner indicator	Appears when toner runs out. For details about adding toner, see page 449 "Replacing the Print Cartridge".
 : Service Call indicator	Appears when the printer is malfunctioning or requires maintenance.
 : Cover Open indicator	Appears when one or more covers of the printer are open.

Checking Printer Status and Settings

This function is available for SP C342DN only.

Maintnc. Info

You can check the following items under [Maintnc. Info]:

- Remaining Toner
Displays the amount of remaining toner.
- Paper Tray
Displays the paper type and size loaded into the paper tray.
- Output Tray Full
Displays whether the output tray is overloaded.
- Paper Misfeed

Displays the state of and solutions for paper misfeeds.

- Cover Open

Indicates whether one or more covers of the printer are open.

Data Storage

You can check the following items under [Data Storage]:

- HDD Remaining Mem.

Displays the amount of available hard disk memory.

- HDD File(s)

Displays the total number of jobs stored on the hard disk.

- Print Job(s)

Displays the number of jobs for "Hold Print Job(s):", "Stored Print Job(s):", "Locked Print Job(s):", and "Sample Print Job(s):".

Machine Adres Info

You can check the following items under [Machine Adres Info]:

- Machine IPv4 Address

Displays the printer's IPv4 address.

- Machine IPv6 Address

Displays the printer's IPv6 address.

1. Press the [Check Status] key, and then check the contents.

[Maintnc/MaInfo] tab ▶ Each key ▶ Check the contents ▶ [Exit]

Note

- [Paper Misfeed], [Output Tray Full], and [Cover Open] appear on [Maintnc. Info] only when these errors occur.
- Depending on the security settings, [Machine Adres Info] might not be displayed.
- For details about how to locate and remove misfeeds, see page 420 "Removing Jammed Paper".

When the Indicator Lamp for the [Check Status] Key Is Lit or Flashing

This function is available for SP C342DN only.

If an indicator for the [Check Status] key lights up, press the [Check Status] key to display the [Check Status] screen. Check the status of the printer in the [Check Status] screen.

[Check Status] screen

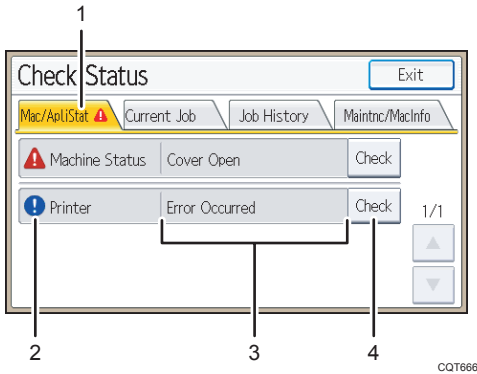

1. [Mac/Apl/Stat] tab

Indicates the status of the printer.

2. Status icons

The icons that can be displayed are described below:

: The printer function is performing a job.

: An error has occurred on the printer.

: An error has occurred in the printer function being used, or the printer function cannot be used because an error has occurred on the printer.

3. Messages

Displays a message that indicates the status of the printer. This icon may also appear if the toner is running low.

4. [Check]

If an error occurs, press [Check] to view details.

Pressing [Check] displays an error message or the printer screen. Check the error message displayed on the printer screen and take the appropriate action. For details about error messages and their solutions, see page 377 "When Messages Are Displayed".

The following table describes problems that cause the indicator to light:

Problem	Cause	Solution
Documents and reports do not print out.	The paper output tray is full.	Remove the prints from the tray.
Documents and reports do not print out.	There is no paper left.	Load paper. For details about loading paper, see page 105 "Loading Paper".
An error has occurred.	A function that has the status "Error Occurred" in	Press [Check], and then check the displayed message and take appropriate action. For details about error messages

Problem	Cause	Solution
	the [Check Status] screen is defective.	and their solutions, see page 377 "When Messages Are Displayed".
The printer is unable to connect to the network.	A network error has occurred.	<ul style="list-style-type: none">• Press [Check], and then check the displayed message and take appropriate action. For details about error messages and their solutions, see page 377 "When Messages Are Displayed".• Check that the printer is correctly connected to the network and that the printer is correctly set. For details about how to connect the network, see page 291 "Interface Settings".• For details about connecting to the network, contact your administrator.• If the indicator is still lit even after trying to solve the problem as described here, contact your service representative.

If USB Connection Fails

Problem	Causes	Solutions
The printer is not automatically recognized.	The USB cable is not connected properly.	Disconnect the USB cable, turn off the printer, and then turn it on again. When the printer has fully booted up, reconnect the USB cable.
Windows has already configured the USB settings.	Check whether or not the computer has identified the printer as an unsupported device.	Open Windows' Device Manager, and then, under [Universal Serial Bus controllers], remove any conflicting devices. A [!] or [?] icon is displayed for conflicting devices. Take care not to accidentally remove required devices. For details, see Windows Help.

When Messages Are Displayed

This section describes the main messages that appear on the display panel and printed error logs and reports. If other messages appear, follow their instructions.

Status Messages

SP C340DN

Message	Status
"@Remote Certif. updating..."	The printer is updating the @Remote certificate. Turn the power off, and then turn it on again.
"Calibrating..."	The printer is calibrating the color. Wait a while.
"Energy Saver Mode"	The printer is in Energy Saver mode. Press any key to recover to the normal mode.
"Hex Dump Mode"	In Hex Dump mode, the printer receives data in a hexadecimal format. Turn off the printer after printing, and then turn it on again.
"Job Suspended"	All jobs are suspended. Turn off the printer, and turn it on again to resume the jobs.
"Offline"	The printer is offline and cannot print.
"Please wait..."	This message may appear for a few seconds. It means the printer is initializing, replenishing toner, or performing maintenance operations. Wait a while.
"Printing..."	The printer is printing. Wait a while.
"Printing Suspended"	Printing is suspended. To resume printing, press the [Suspend/Resume] key.
"Ready"	This is the default ready message. The printer is ready for use. No action is required.
"Resetting Job"	The printer is resetting the print job. Wait a while.
"Setting change..."	The printer is applying the changes made to its settings. Wait a while.
"Waiting for print data..."	The printer is waiting for the next data to print. Wait a while.

SP C342DN

Message	Status
"Calibrating..."	The printer is calibrating the color. Wait a while.
"Hex Dump Mode"	In Hex Dump mode, the printer receives data in a hexadecimal format. Press [Job Reset] to cancel Hex Dump mode.
"Job suspended."	Printing was temporarily suspended because [Job Operation] or the [Suspended] key was pressed.
"Loading Toner..."	The printer is loading the toner. Wait a while.
"Offline"	The printer is offline.
"Please wait."	This message might appear for a second or two while the printer is preparing, performing initial adjustments, or adding toner. Wait a while.
"Printing..."	The printer is printing. Wait a while.
"Ready"	This is the default ready message. The printer is ready for use. No action is required.
"Resetting job..."	The printer is resetting the print job. Wait until "Ready" appears on the display panel.
"Setting change..."	The printer is changing settings. You cannot use the control panel while this message is displayed. Wait a while.
"Updating certif..."	The @Remote certificate is being updated. Wait a while.
"Waitg. for prt.data"	The printer is waiting for the next data to print. Wait a while.

Alert Messages (Displayed on the Control Panel)**SP C340DN**

Message	Cause	Solution
"(A) Remove paper from Trays. Opn & cls Frt. Cov."	Open the front cover and remove the jammed paper from the paper feed path.	For details, see page 420 "Removing Jammed Paper".

Message	Cause	Solution
"  (B) Open Front Cover and remove the paper."	Open the front cover and remove the jammed paper from the internal paper feed path.	For details, see page 420 "Removing Jammed Paper".
"  (C) Open Front Cover and remove the paper."	Open the front cover and remove any jammed paper from the output tray.	For details, see page 420 "Removing Jammed Paper".
"  (Y) Remove misfeed in Trays. Opn & cls Frt. Cov."	Open the front cover and remove any jammed paper.	For details, see page 420 "Removing Jammed Paper".
"  (Z) Open Front Cover and remove the paper."	Open the front cover and remove any jammed paper from the paper duplex unit.	For details, see page 420 "Removing Jammed Paper".
"  Out of toner"	The color toner has run out. Replace the toner cartridge.	For details, see page 449 "Replacing the Print Cartridge".
"  Waste Toner Bottle full"	Replace the waste toner bottle.	For details, see page 451 "Replacing Other Consumables".
"Cannot connect=>Comm.Serv. Check proxy user/ password."	The proxy user name or password is incorrect.	Check the proxy server settings, and then change the user name and/or password if they are incorrect.
"Cannot connect with DHCP server.(101/201)"	An IP address cannot be obtained from the DHCP server.	Contact your network administrator.
"Cannot print."	The printer cannot print the sent data.	Check that the file you want to print is a supported file type. Check the misfeeds and ask your network administrator for help.
"Change (Tray name) to the following settings:"	The size of the paper in the tray does not match the paper size specified in the printer driver.	Select a tray containing paper that is the same size as the specified paper size.
"Check network settings. (103/203)"	The IP address setting is incorrect.	Check the IP address, subnet mask, and gateway address.
"Classification Code Error"	A classification code is not specified for the print job.	Enter a classification code using the printer properties and print the document again.

Message	Cause	Solution
"Connect failed:WirelessCard Turn power off, check card."	The printer cannot detect the wireless LAN interface board.	Check that the board is supported or installed correctly.
"Cover Open. Please close the indicated cover."	A cover of the printer is open.	Close the cover as indicated on the control panel.
"Duplex mode is in off position for (tray name)"	The duplex mode for the indicated tray is not available.	You can use one-sided printing only. Press [Change] to change the tray's settings, press [JobReset] to reset the job, or press [Form Feed] to force printing.
"ECO Night Sensor did not turn Power Switch off. Turn switch off manually or to use, press any key."	Auto power off by the [ECO Night Sensor] function failed.	Turn off the power manually, or press any key to use [ECO Night Sensor] auto power off function.
"Ethernet Board Error"	An error on the Ethernet is detected.	Turn the printer off, and then turn it on again. If the problem persists, contact your sales or service representative.
"Failed to connect to server for Remote Diagnostics."	The printer cannot communicate with Remote Communication Gate.	Check the connection to the Remote Server Gate.
"IPv6 Address already exists Link-local Address(109/209)"	The same IPv6 address is already used.	Contact your network administrator.
"IPv6 Address already exists Stateless Address(109/209)"	The same IPv6 address is already used.	Contact your network administrator.
"IPv6 Address already exists Manual Config. Address(109/209)"	The same IPv6 address is already used.	Contact your network administrator.
"Load paper in (tray name) or [Cancel] to FormFeed."	There is no paper in the specified tray.	Load the specified paper in the tray, press [JobReset] to reset the job. To print from the bypass tray on paper whose width is less than 90 mm, cancel the print job, and

Message	Cause	Solution
		then, under [System], set [Bypass Print: 64-90 mm] to [Active].
"May have exceeded max no. of prints in output tray. Print stopped. Check the tray."	The output tray is full.	Remove paper from the output tray.
"Parallel I/F Error"	The printer's self diagnostic test failed due to a loopback error.	Replace the IEEE 1284 board that caused the error.
"Printer Font Error."	There are problems with the printer's font file.	Turn the printer off, and then turn it on again. If the problem persists, contact your sales or service representative.
"Problem:Wireless board Please call service."	The printer cannot detect a wireless LAN interface board.	Check that the wireless LAN interface board installed correctly. If the problem persists, contact your sales or service representative.
"Replacement Alert Replace Transfer Belt."	You need to replace the intermediate transfer unit.	Contact your sales or service representative to obtain a new intermediate transfer unit.
"Replacmnt Requird:InfTrans"	You need to replace the intermediate transfer unit.	For details, see page 451 "Replacing Other Consumables".
"Replcmnt Requird: Print Cart"	The toner has run out, or the photo conductor unit has reached the end of its service life.	For details, see xxxxx "Replacing the Print Cartridge".
"Replacmnt Rqrd:Fusing Unit"	You need to replace the fusing unit.	For details, see page 451 "Replacing Other Consumables".
"Replcmnt Rqrd Soon:InfTrans"	You will need to replace the intermediate transfer unit soon.	Contact your sales or service representative to obtain a new unit.
"Repl Requird Soon:FusingUnit"	You will need to replace the fusing unit soon.	Contact your sales or service representative to obtain a new unit.

Message	Cause	Solution
"SD Card authenticatn.failed"	Authentication from the SD card failed.	Turn the printer off, and then turn it on again. If the problem persists, contact your sales or service representative.
"Set the Fusing Unit correctly."	The fusing unit may not be installed correctly. Turn the printer off and re-install the fusing unit. If the message is still displayed after re-installation, contact your sales or service representative.	For details, see page 451 "Replacing Other Consumables".
"Set the Intermediate Transfer Unit correctly."	The intermediate transfer unit may not be installed correctly. Turn the printer off and re-install the intermediate transfer unit. If the message is still displayed after re-installation, contact your sales or service representative.	For details, see page 451 "Replacing Other Consumables".
"Set the Print Cartridge correctly."	The print cartridge may have not been installed correctly.	Turn the printer off, and install the print cartridge again.
"Set Waste Toner Bottle correctly."	The waste toner bottle may not be installed correctly. Turn the printer off and re-install the waste toner bottle. If the message is still displayed after re-installation, contact your sales or service representative.	For details, see page 451 "Replacing Other Consumables".
"Output Tray is full. Remove paper."	The output tray is full.	Remove the paper.
"Supply order has failed."	The automatic supply order failed.	The message indicates the printer tried to order the supplies.
"This NetBIOS name is already in use.(108/208)"	The NetBIOS name specified for the printer is already used by another device on the network.	Contact your network administrator.

Message	Cause	Solution
"The same IPv4 Address already exists.(102/202)"	The IPv4 address specified for the printer is already used by another device on the network.	Contact your network administrator.
"The selected job has already been printed or deleted."	This message might appear if you print or delete a job from Web Image Monitor.	Press Exit on the message screen.
"USB has a problem. / Please call service."	The printer has detected a USB board failure.	Turn the printer off, and then turn it on again. If the problem persists, contact your sales or service representative.
"Values set for IPv6/ Gateway addresses are invalid.(110/210)"	The IPv6 address or gateway address is invalid.	Check the network settings.
"WPA Auth. incomplete. (211)"	WPA authentication could not be completed.	Contact your network administrator.

SP C342DN

Message	Cause	Solution
"Cannot connect with the wireless card. Turn the main power switch off, then check the card."	<ul style="list-style-type: none"> The wireless LAN interface board was not inserted when the printer was turned on. The wireless LAN interface board was pulled out after the printer was turned on. The settings are not updated although the unit is detected. 	<ul style="list-style-type: none"> Turn off the main power switch, and then confirm the wireless LAN interface board is inserted correctly. For details about installing the board, contact your service representative. If the message appears again, contact your service representative.
"Cannot print because both the main and designation (chapter) sheets are set to the same paper tray. Press [Job Reset] to cancel the job."	The tray selected for other pages is the same as the one for slip sheets.	Reset the job. Be sure the tray you select for slip sheets is not providing paper for other pages.

Message	Cause	Solution
"Hardware Problem: Ethernet"	An error has occurred in the Ethernet interface.	Turn the main power switch off and then back on again. If the message appears again, contact your service representative.
"Hardware Problem: HDD"	An error has occurred in the hard disk.	<ul style="list-style-type: none"> • Turn the main power switch off and then back on again. If the message appears again, contact your service representative. • The hard disk may have not been installed properly if you have installed it yourself. Check that it is properly installed For details about installing the unit, see page 59 "Installing the Hard Disk".
"Hardware Problem: Parallel I/F"	An error has occurred in the IEEE 1284 interface board.	<ul style="list-style-type: none"> • Turn the main power switch off and then confirm the IEEE 1284 interface board is inserted correctly. For details about installing the board, see page 63 "Installing the Interface Units". • If the message appears again, contact your service representative.
"Hardware Problem: USB"	An error has occurred in the USB interface.	Turn the main power switch off and then back on again. If the message appears again, contact your service representative.
"Hardware Problem: Wireless Card" (A "wireless LAN interface board" is referred to as a "wireless card".)	The wireless LAN interface board can be accessed, but an error was detected.	<ul style="list-style-type: none"> • Turn off the main power switch, and then confirm the wireless LAN interface board is inserted correctly. For details about installing the board, see page 63

Message	Cause	Solution
		<p>"Installing the Interface Units".</p> <ul style="list-style-type: none"> If the message appears again, contact your service representative.
"Load ppr blw in (Tray name)."	The printer driver settings are incorrect or the tray does not contain paper of the size selected in the printer driver.	Check that the printer driver settings are correct, and then load paper of the size selected in the printer driver into the input tray. For details about how to change the paper size, see page 105 "Loading Paper".
"No toner. Replace Toner Cartridge."	The toner has run out. Replace the print cartridge.	For details, see page 449 "Replacing the Print Cartridge".
"No color toner. Color toner is required to print in black & white with the current paper type. Replace the color Print Cartridge or press [Job Reset] to cancel printing."	The color toner has run out. Replace the print cartridge.	For details, see page 449 "Replacing the Print Cartridge".
"n ppr siz msmtch Select new tray or use ppr size below." ("n" is a tray name.)	The size of the paper in the tray does not match the paper size specified in the printer driver.	Select a tray containing paper that is the same size as the specified paper size.
"Problem: Printer Font Error"	An error has occurred in the font settings.	Contact your service representative.
"Problems with the wireless board. Please call service." (A "wireless LAN interface board" is referred to as a "wireless board".)	The printer has detected a wireless LAN interface board failure.	If the message appears again, contact your service representative.
"Output Tray is full. Remove paper."	The output tray is full.	Remove the paper.

Message	Cause	Solution
"Replacement of Fusing Unit is now necessary. Please call service."	You need to replace the intermediate fusing unit.	For details, see page 451 "Replacing Other Consumables".
"Fusing Unit must be replaced now. Replace Fusing Unit."	You need to replace the fusing unit.	For details, see page 451 "Replacing Other Consumables".
"Replacement of Fusing Unit will soon be necessary. A new unit is required. Please contact your local vendor."	You will need to replace the fusing unit soon.	Contact your sales or service representative to obtain a new unit.
"Replacement of Transfer Unit is now necessary. Replace Transfer Unit."	You need to replace the intermediate transfer unit.	For details, see page 451 "Replacing Other Consumables".
"Replacement of Transfer Unit is now necessary. Replace Transfer Unit."	You need to replace the intermediate transfer unit.	For details, see page 451 "Replacing Other Consumables".
"Replacement of Transfer Unit will soon be necessary. A new unit is required. Please contact your local vendor."	You will need to replace the intermediate transfer unit soon.	Contact your sales or service representative to obtain a new unit.
"Tray setg. do not match spcfd siz&typ. Select new tray or use siz&typ below."	The printer driver settings are incorrect or the tray does not contain paper of the size or type selected in the printer driver.	<ul style="list-style-type: none"> • Check that the printer driver settings are correct, and then load paper of the size selected in the printer driver into the input tray. For details about how to load paper, see page 105 "Loading Paper". • Select the tray manually to continue printing, or cancel a print job. For details about how to select the tray manually, or cancel a print job, see page 207 "If an Error Occurs with the

Message	Cause	Solution
		Specified Paper Size and Type".
"Waste Toner Bottle is full. Replace the bottle."	The waste toner bottle is full.	Replace the waste toner bottle. For details, see page 451 "Replacing Other Consumables".

Messages during Direct print from a memory storage device

Message	Causes	Solutions
"Unable to access the specified memory storage device."	The memory device used cannot be recognized.	For details about the recommended memory devices for the Direct printing function from memory storage devices, contact your service representative. The USB flash memory device that features password protection or other security features may not work normally.

Alert Messages (Printed on Error Logs and Reports)

This section describes likely causes of and possible solutions for the error messages that are printed on the error logs or reports.

SP C340DN

Message	Cause	Solution
"Address book is in use."	The printer currently cannot perform authentication because the Address Book is being used by another function.	Wait a while, and then retry the operation.
"Auto-user prog. failed."	Automatic registration of information for LDAP Authentication or Windows Authentication failed because the Address Book is full.	For details about the automatic registration of user information, see Security Guide.

Message	Cause	Solution
"Cannot print."	You have no privileges to print the PDF file you want to print.	Contact the owner of the document.
"Classification Code Error"	The classification code is not specified with the printer driver.	Select [Optional] for the classification code. For details about how to specify classification code settings, see page 149 "Registering Classification Codes".
"Collate cancelled."	Collate was canceled.	Turn the printer off, and then turn it on again. If the message appears again, contact your service representative.
"Collate: Page max."	The amount of free memory is insufficient to perform collating.	Reduce the number of pages to be printed.
"Command Error."	An RPCS command error occurred.	Check that the communication between a device and the printer is working correctly.
"Compressed Data Error"	The printer detected corrupt compressed data.	Check that the program you used to compress the data is functioning correctly.
"Duplex cancelled."	Duplex printing was canceled.	Change the setting for "Duplex Tray" in [Paper Input] to enable duplex printing for the paper tray.
"Error occured. Prntd/Cncl."	An error occurred during printing, but it was ignored.	Check the print settings.
"Excd Prt Vol Use max count."	Printing was canceled because the print maximum number was reached.	Contact your user administrator.
"Excd Prt Vol Use max count."	Maximum number of user codes that can be registered has been reached.	Delete unnecessary user codes.
"File System Error."	PDF direct printing could not be performed because the file system could not be obtained.	Turn the printer off, and then turn it on again. If the message appears

Message	Cause	Solution
		again, contact your service representative.
"File System Full."	The PDF file cannot be printed because the capacity of the file system is full.	Delete all unnecessary files from the hard disk, or decrease the file size sent to the printer.
"Function use denied."	The print job was cancelled because of one of the following: <ul style="list-style-type: none"> • The user does not have privileges to print. • No privileges to print are assigned to the entered user name or user code, or • A wrong password was specified for the user name. 	Enter the user name or user code with privileges to print, or enter the correct password for the user name.
"I/O buffer overflow."	An input buffer overflow occurred.	<ul style="list-style-type: none"> • Select [Font Priority] for [Memory Usage] in [System]. • In [I/O Buffer] under the [Host Interface] menu, set the maximum buffer size to a larger value. • Reduce the number of files being sent to the printer.
"No response from server."	A timeout occurred while the printer was connecting to the server for LDAP Authentication or Windows Authentication.	Check the status of the server.
"Paper Size Error"	Printing was canceled because the specified paper size cannot be fed from the tray.	Check the available paper size.
"Paper Type Error"	The printer does not recognize the paper type specified using the printer driver.	Check that the printer is connected to the network correctly and bidirectional communication is enabled. If the

Message	Cause	Solution
		problem persists, check the user paper type settings of the printer.
"Password mismatch."	A wrong password was entered when an encrypted PDF file was printed.	Check the password.
"PDF File Error."	A syntax error, etc., occurred.	Check that the PDF file is valid.
"Print overrun."	Printing images was aborted.	Select a lower resolution on the printer driver. For details about how to change the resolution setting, see the printer driver Help.
"Receiving data failed."	Data reception was aborted.	Resend the data.
"Sending data failed."	The printer received a command to stop a transmission from the printer driver.	Check that the computer is working correctly.
"User auth. already exists."	The same account name is already used in the newly selected domain or server in an environment using LDAP Authentication or Integration Server Authentication.	Contact your user administrator.

SP C342DN

Message	Cause	Solution
"98: Error"	The printer could not access the hard disk correctly.	Turn the main power switch off and then back on again. If the message appears frequently, contact your service representative.
"Address Book is currently in use by another function. Authentication has failed."	The printer currently cannot perform authentication because the Address Book is being used by another function.	Wait a while, and then retry the operation.

Message	Cause	Solution
"Auto-registration of user information has failed."	Automatic registration of information for LDAP Authentication or Windows Authentication failed because the Address Book is full.	For details about automatic registration of user information, see Security Guide.
"Classification Code is incorrect."	The classification code has not been entered, or the classification code has been entered incorrectly.	Enter the correct classification code.
"Classification Code is incorrect."	The classification code is not supported by the printer driver.	Select [Optional] for the classification code. For details about how to specify classification code settings, see page 149 "Registering Classification Codes".
"Collate has been cancelled."	Collate was canceled.	Decrease the number of files sent to the printer.
"Command Error."	An RPCS command error occurred.	Check that the communication between the digital camera and the printer is working correctly.
"Command Error"	An RPCS command error occurred.	Check that the communication between a device and the printer is working correctly.
"Compressed Data Error."	The printer detected corrupt compressed data.	<ul style="list-style-type: none"> • Check the connection between the computer and the printer. • Check that the program you used to compress the data is functioning correctly.
"Data storage error."	You tried to print a Sample Print, Locked Print, Hold Print, or Stored Print file while the hard disk was not installed.	The hard disk is required when printing a Sample Print, Locked Print, Hold Print, or Stored Print. If the message appear after installing the hard disk, contact your service representative.

Message	Cause	Solution
"Duplex has been cancelled."	Duplex printing was canceled.	<ul style="list-style-type: none"> Select the proper paper size for the duplex function. For details about paper size, see page 106 "Paper Size Specifications". Change the setting for "Apply 2 sided" in [System Settings] to enable duplex printing for the paper tray. For details about setting "Apply 2 sided", see page 287 "Tray Paper Settings".
"Error has occurred."	A syntax error, etc., occurred.	Check that the PDF file is valid.
"Error occurred. Either job was printed with settings changed or it was cancelled."	An error occurred during printing, but it was skipped.	Check that the data is valid.
"Exceed max. No. of files to print for temp./stored jobs."	While printing a Sample Print, Locked Print, Hold Print, or Stored Print file, the maximum file capacity was exceeded.	Delete unneeded files stored in the printer.
"Exceed max. No. of files (AT)"	While using the error job store function to store Normal Print jobs as Hold Print files, the maximum file capacity for file storage or Hold Print file management (automatic) was exceeded.	Delete Hold Print files (automatic) or unneeded files stored in the printer.
"Exceed max. No. of pages(AT)"	While using the error job store function to store Normal Print jobs as Hold Print files, the maximum page capacity was exceeded.	<ul style="list-style-type: none"> Delete unneeded files stored in the printer. Reduce the number of pages to print.
"Exceeded max. No. of pages for temporary/stored jobs."	While printing a Sample Print, Locked Print, Hold Print, or Stored Print file, the maximum page capacity was exceeded.	<ul style="list-style-type: none"> Delete unneeded files stored in the printer. Reduce the number of pages to print.

Message	Cause	Solution
"Exceeded max. pages. Collate is incomplete."	The number of pages exceeds the maximum number of sheets that can be used with Collate.	Reduce the number of pages to print.
"Exceeded the maximum unit count for Print Volume Use. The job has been cancelled."	The number of pages the user is permitted to print has been exceeded.	For details about Print Volum. Use Limit., see Security Guide.
"Failed to obtain file system."	PDF direct printing could not be performed because the file system could not be obtained.	Turn off the main power switch and then back on again. If the message appears again, contact your service representative.
"File system is full."	The PDF file does not print out because the capacity of the file system is full.	Delete all unnecessary files from the hard disk, or decrease the file size sent to the printer.
"HDD is full."	The hard disk became full while printing a Sample Print, Locked Print, Hold Print, or Stored Print file.	<ul style="list-style-type: none"> • Delete unneeded files stored in the printer. • Reduce the data size of the Sample Print, Locked Print, Hold Print, or Stored Print file.
"HDD is full."	When printing with the PostScript 3 printer driver, the hard disk capacity for fonts and forms has been exceeded.	Delete unneeded forms or fonts registered in the printer.
"HDD is full. (Auto)"	The hard disk became full while using the error job store function to store Normal Print jobs as Hold Print files.	<ul style="list-style-type: none"> • Delete unneeded files stored in the printer. • Reduce the data size of the Temporary Print file and/or the Stored Print file.
"I/O buffer overflow."	An input buffer overflow occurred.	<ul style="list-style-type: none"> • Select [Font Priority] for [Memory Usage] in [System]. • In [I/O Buffer] under the [Host Interface] menu, set the

Message	Cause	Solution
		<p>maximum buffer size to a larger value.</p> <ul style="list-style-type: none"> • Reduce the number of files being sent to the printer.
"Information for user authentication is already registered for another user."	The user name for LDAP Authentication or Integration Server Authentication was already registered in a different server with a different ID, and a duplication of the user name occurred due to a switching of domains (servers), etc.	For details about User Authentication, see Security Guide.
"Insufficient Memory"	A memory allocation error occurred.	<p>PCL 5/PostScript 3</p> <p>Select a lower resolution on the printer driver. For details about how to change the resolution setting, see the printer driver Help.</p> <p>PCL 6</p> <p>Select a lower resolution on the printer driver. For details about how to change the resolution setting, see the printer driver Help. On the printer driver's [Detailed Settings] tab, click [Print Quality] in "Menu:", and then select [Raster] in the "Vector/Raster:" list. In some cases, it will take a long time to complete a print job.</p>
"Memory Retrieval Error"	A memory allocation error occurred.	Turn off the main power switch and then back on again. message appears again.
"No response from the server. Authentication has failed."	A timeout occurred while connecting to the server for LDAP	Check the status of the server.

Message	Cause	Solution
	Authentication or Windows Authentication.	
"Print overrun."	Images were discarded while printing.	Select a lower resolution on the printer driver. For details about how to change the resolution setting, see the printer driver Help.
"Printing privileges have not been set for this document."	The PDF document you have tried to print has no privileges to print.	Contact the owner of the document.
"Receiving data failed."	Data reception was aborted.	Resend the data.
"The selected paper size is not supported. This job has been cancelled."	Job Reset is automatically performed if the specified paper size is incorrect.	Specify the correct paper size, and then print the file again.
"Sending data failed."	The printer received a command to stop transmission from the printer driver.	Check that the computer is working correctly.
"Unauthd. Copy Preventn. Error"	The [Enter User Text:] field on the [Unauthorized Copy Prevention for Pattern Details] screen is blank.	PCL 6/PostScript 3 On the printer driver's [Detailed Settings] tab, click [Effects] in "Menu:". Select [Unauthorized Copy Prevention], and then click [Details] to display [Unauthorized Copy Prevention for Pattern Details]. Enter text in [Enter User Text:].
"User Paper Type Error"	The printer does not recognize the paper type specified using the printer driver.	Check that the printer is connected to the network correctly and bidirectional communication is enabled. If the problem persists, confirm the user paper type settings of the printer. For details, see page 127 "Registering Unique Names to Paper Types".

Message	Cause	Solution
"You do not have a privilege to use this function. This job has been cancelled."	The entered Login User Name or Login Password is not correct.	Check that the Login User Name and Login Password are correct.
"You do not have a privilege to use this function. This job has been cancelled."	The logged in user is not allowed to use the selected function.	For details about how to set permissions, see Security Guide.
"You have no privilege to use this func. Operation canceled."	The logged in user does not have the privileges to register programs or change the paper tray settings.	For details about how to set permissions, see Security Guide.

Messages during Direct print from a memory storage device

Message	Causes	Solutions
"99: Error"	This data cannot be printed. The specified data is either corrupt or not supported by the Direct printing function from memory storage devices.	Check that the data is valid. For details about the kinds of data supported by the Direct printing function from memory storage devices, see page 191 "Direct Printing from a Memory Storage Device".

If printing does not start, contact your service representative.

Note

- The contents of errors may be printed on the Configuration Page. Check the Configuration Page in conjunction with the error log. For details about how to print the Configuration Page, see page 100 "Test Printing".

When You Cannot Print

Problem	Cause	Solution
Printing does not start.	The power is off.	For details about how to turn on the main power switch, see page 73 "Turning On/Off the Power".
Printing does not start.	The cause is displayed on the screen of the control panel.	Check the error message or warning status on the display panel, and then take the required action. For details about solutions, see page 377 "When Messages Are Displayed".
Printing does not start.	The interface cable is not connected correctly.	For details about how to connect interface cables correctly, see page 78 "Connecting the Printer".
Printing does not start.	The correct interface cable is not being used.	The type of interface cable to use depends on the computer. Be sure to use the correct one. If the cable is damaged or worn, replace it. For details about interface cable, see page 78 "Connecting the Printer".
Printing does not start.	The interface cable was connected after the printer was switched on.	Connect the interface cable before turning on the main power switch.
Printing does not start.	If the printer is using wireless LAN, failure to print might result from a weak wireless signal.	Check the radio signal status of the wireless LAN in [System Settings]. If the signal quality is not satisfactory, move the printer to a location where radio waves can pass or remove objects that might cause interference. You can check the signal status only when wireless LAN is used in infrastructure mode. For details

Problem	Cause	Solution
		<p>about the radio signal status of the wireless LAN, see:</p> <ul style="list-style-type: none"> • page 255 "Host Interface (SP C340DN)" (for SP C340DN) • page 291 "Interface Settings" (for SP C342DN)
Printing does not start.	If the printer is using wireless LAN, when there is a microwave oven, mobile phone, industrial machine, scientific instrument, or medical instrument which uses the same frequency range near the device, radio waves may be interfering with the wireless LAN's communication.	Turn off the microwave oven, mobile phone, industrial machine, scientific instrument, or medical instrument which uses the same frequency range and then try printing again. If printing is successful, move the device to a location where it does not interfere.
Printing does not start.	If the printer is using wireless LAN, SSID settings may be incorrect.	Check that the SSID is correctly set using the printer's display panel. For details about SSID Setting, see page 85 "Connecting to the Wireless LAN Interface".
Printing does not start.	If the printer is using wireless LAN, the receiver's MAC address may be preventing communication with the access point.	Check the access point settings when using the infrastructure mode. Depending on the access point, client access may be filtered by MAC address. Also, check that there are no transmission problems between the access point and wired clients, and between the access point and wireless clients.
Printing does not start.	The wireless LAN interface is not working.	Make sure the orange LED is lit, and the green LED is lit or flashing during transmission.

Problem	Cause	Solution
Printing does not start.	The Login User Name, Login Password, or Driver Encryption Key is incorrect.	Check the Login User Name, Login Password, and Driver Encryption Key.
Printing does not start.	Advanced encryption has been set using the Extended Security function.	Check the settings of the Extended Security function. For details about Extended Security function settings, see Security Guide.
[List / Test Print] is disabled.	A mechanical error might have occurred.	Contact your service representative.
Printing does not start when using the extended wireless LAN in Ad-hoc Mode.	The correct Communication Mode is not set.	<ul style="list-style-type: none"> • Turn the main power switch off and then back on again. For details about how to turn on/off the main power switch, see page 73 "Turning On/Off the Power". • Change [Communication Mode] in [System Settings] to [802.11 Ad-hoc Mode], and then select [Off] for [Security Method]. For details about Communication Mode, see: <ul style="list-style-type: none"> • page 255 "Host Interface (SP C340DN)" (for SP C340DN) • page 291 "Interface Settings" (for SP C342DN)

If printing does not start, contact your service representative.

When the Data In Indicator Does Not Light Up or Flash

When the Data In indicator does not light up or flash after a print job starts, data is not being sent to the printer.

When the printer is connected to the computer using the interface cable

Check that the print port setting is correct. When connecting the printer to the computer using a parallel interface, connect using LPT1 or LPT2.

1. Open the printer properties dialog box, and then click the [Ports] tab.

For details about displaying the printer properties dialog box, see page 131 "Displaying the Printer Driver Properties with Windows".

2. In the [Print to the following port(s)] list, check that the correct port is selected.

Network connection

For details about the network connection, contact your administrator.

Other Printing Problems

This section describes likely causes of and possible solutions for problems that can occur when a print job is performed from a computer.

When You Cannot Print Properly

Problem	Cause	Solution
The printed image is smudged.	Settings for thick paper have not been configured when printing on thick paper in the bypass tray.	<p>PCL 5e/5c</p> <p>On the printer driver's [Paper] tab, select [Bypass Tray] in the "Input Tray:" list. Then in the "Type:" list, select a proper paper type.</p> <p>PCL 6/PostScript 3</p> <p>On the printer driver's [Detailed Settings] tab, click [Paper] in "Menu:", and then select [Bypass Tray] in the "Input Tray:" list. Then in the "Paper Type:" list, select a proper paper type.</p>
Printed images contain blots or are patchy.	The paper is damp.	Use paper that has been stored in the recommended temperature and humidity conditions. For details about the proper way to store paper, see page 110 "Paper Precautions".
Printed images contain blots or are patchy.	The printer is not on a level surface.	The printer must be placed on a stable and level surface. Check the printer environment and select an appropriate location. For details about the printer's environment, see page 47 "Install Location".
Printed images contain blots or are patchy.	The paper is creased, curled, or has blemishes.	Smooth out the wrinkles or replace the paper. For details

Problem	Cause	Solution
		about paper, see page 110 "Paper Precautions".
The printed image is faded over the entire page.	The paper is damp.	Use paper that has been stored in the recommended temperature and humidity conditions. For details about the proper way to store paper, see page 110 "Paper Precautions".
The printed image is faded over the entire page.	The paper is unsuitable. Printing on coarse or treated paper might result in faint print image.	Use recommended paper. For details about recommended paper, see page 106 "Paper Size Specifications" and page 108 "Paper Type Specifications".
The printed image is faded over the entire page.	If [On] is selected in the "Economy Color" list in the printer driver settings, the entire page will be faded when printed.	PCL 6/PostScript 3 On the printer driver's [Detailed Settings] tab, click [Print Quality] in "Menu:", and then select [Off] in the "Economy Color".
Images smudge when rubbed. (Toner is not fixed.)	The specified paper type and the paper that is actually loaded might be different. For example, thick paper might be loaded but not specified as the paper type.	PCL 5e/5c On the printer driver's [Paper] tab, select a proper paper type in the [Type:] box. PCL 6/PostScript 3 On the printer driver's [Detailed Settings] tab, click [Paper] in "Menu:", and then select a proper paper type in the "Paper Type:" list.
The printed image is different from the image on the computer's display.	Printing will be performed by the printer's graphic processing function.	PCL 6 On the printer driver's [Detailed Settings] tab, click [Print Quality] in "Menu:",

Problem	Cause	Solution
		and then select [Raster] in the "Vector/Raster:" list.
The image is too dark or too light.	The paper type settings are not configured correctly.	Check that the paper loaded on the paper tray or bypass tray matches the paper type set on the display panel. For details about paper type settings, see page 125 "Paper Settings".
The image is too dark or too light.	The paper is loaded reverse side up. Printing on non-print surfaces reduces print quality and can damage the printer's internal components.	Before printing on special paper, check its surface carefully. For details about special paper, see page 110 "Paper Precautions".
Image is dirty.	Use of non-recommended toner can result in a loss of print quality and other problems.	Use genuine manufacturer toner. Contact your service representative.
Horizontal lines appear when an image filled in black is printed.	A black-and-white image is occasionally recognized as a color image and printed as a streak when a large number of pages that contain both black-and-white and color images are printed continuously.	<ul style="list-style-type: none"> • Set [B&W Page Detect] or [Black & White Page Detect] to [Per Page]. For details, see one of the followings depending on the model being used: <ul style="list-style-type: none"> • page 234 "System (SP C340DN)" (for SP C340DN) • page 327 "Maintenance: Print" (for SP C342DN) • Change [Gray Reproduction] in the [Print Quality] menu of the printer driver to [CMY + K].
Horizontal streaks appear on the printed page.	Horizontal streaks may sometimes appear on the printed pages when a large number of pages are	Perform the automatic gradation correction. For details, see page 441 "Correcting the Color Gradation".

Problem	Cause	Solution
	continuously printed in a high-temperature or humid environment.	
The lower half of the page appears faded when a filled-in image is printed.	When the "Toner is almost empty." or "Toner Cartridge is almost empty. Replace Toner Cartridge." message is displayed on the display panel, the toner is running low and the printed page may appear faded.	Replace the print cartridge.
Printed graphics do not match graphics on the screen.	If the printer driver is configured to use the graphics command, the graphics command from the printer is used to print.	If you want to print accurately, set the printer driver to print without using the graphics command. For details about settings for printer driver, see the printer driver Help.
Print result differs from the display.	A non-Windows operating system is being used.	Check that the application supports the printer driver.
Print result differs from the display.	The printer is not selected for printing.	Use the printer driver of the printer and check that the printer is the specified printer. For details about how to open the printer driver settings screen, see page 131 "Displaying the Printing Preferences dialog box from the [Start] menu".
Print result differs from the display.	Data transmission failed or was canceled during printing.	Check whether there is failed or canceled data remaining. For details about how to identify the cause of the error, see page 210 "Checking Error Logs".
Characters differ from the display.	The loaded paper is unsuitable.	Printing on recommended paper produces better resolution. For details about recommended paper, see page 106 "Paper Size Specifications" and

Problem	Cause	Solution
		page 108 "Paper Type Specifications".
Image position differs from the display.	The page layout settings are not configured correctly.	Check the page layout settings configured using the application. For details about page layout settings, see the application's Help.
Image position differs from the display.	The page layout settings are not configured correctly.	<p>PCL 5e/5c</p> <p>On the printer driver's [Paper] tab, select [Print On] box, and then select the desired size.</p> <p>PCL 6 / PostScript 3</p> <p>On the printer driver's [Detailed Settings] tab, click [Basic] in "Menu:", and then select the desired size in the "Print On:" list.</p>
Lines of garbled or unwanted alphanumeric characters appear.	An incorrect printer language might have been selected.	Select the correct printer driver, and then print the file again.
Images are cut off, or excess is printed.	You may be using paper smaller than the size selected in the application.	Use the same size paper as that selected in the application. If you cannot load paper of the correct size, use the reduction function to reduce the image, and then print. For details about the reduction function, see the printer driver Help.
Photo images are grainy.	Some applications print at a lower resolution.	Use the application's or printer driver's settings to specify a higher resolution. For details about printer driver's settings, see the printer driver Help.

Problem	Cause	Solution
A solid line is printed as a dashed line or appears blurred.	Dither patterns do not match.	PostScript 3 Change the dithering settings on the printer driver. For details about the dithering settings, see the printer driver Help.
Fine lines are fuzzy with inconsistent thickness or color, or do not appear.	Super fine lines have been specified in the application, or a color that is too light has been specified for the lines.	PostScript 3 Change the dithering settings on the printer driver. For details about the dithering settings, see the printer driver Help. If the problem continues after you change the dithering settings, use the settings of the application in which the image was created to change the color and thickness of the lines.
Images appear only partially colored.	The paper is damp.	Use paper that has been stored in the recommended temperature and humidity conditions. For details about the proper way to store paper, see page 110 "Paper Precautions".

Paper Misfeeds Occur Frequently

Problem	Cause	Solution
Paper is not fed from the selected tray.	When you are using Windows, printer driver settings override those settings using the display panel.	PCL 5e/5c On the printer driver's [Paper] tab, select the desired input tray in the "Input Tray:" list.

Problem	Cause	Solution
		PCL 6/PostScript 3 On the printer driver's [Detailed Settings] tab, click [Paper] in "Menu:", and then select the desired input tray in the "Input Tray:" list.
Images are printed at a slant.	The tray's side fences might not be locked.	Check that the side fences are locked. For details about how to set the side fences, see page 113 "Loading Paper into Paper Trays" or page 119 "Loading Paper into the Bypass Tray".
Images are printed at a slant.	The paper is feeding in at a slant.	Load the paper correctly. For details about loading paper, see page 113 "Loading Paper into Paper Trays" or page 119 "Loading Paper into the Bypass Tray".
Misfeeds occur frequently.	The number of sheets loaded exceeds the capacity of the printer.	Load paper only as high as the upper limit markings on the side fences of the paper tray, or the markings on the paper guides of the bypass tray.
Misfeeds occur frequently.	The paper tray's side fences are set too tightly.	Push the side fences lightly, and then reset them.
Misfeeds occur frequently.	The paper is damp.	Use paper that has been stored in the recommended temperature and humidity conditions. For details about the proper way to store paper, see page 110 "Paper Precautions".
Misfeeds occur frequently.	The paper is too thick or too thin.	Use recommended paper. For details about recommended paper, see page 106 "Paper Size Specifications" and

Problem	Cause	Solution
		page 108 "Paper Type Specifications".
Misfeeds occur frequently.	The paper is wrinkled or has been folded/creased.	<ul style="list-style-type: none"> • Use recommended paper. For details about recommended paper, see page 106 "Paper Size Specifications" and page 108 "Paper Type Specifications". • Use paper that has been stored in the recommended temperature and humidity conditions. For details about the proper way to store paper, see page 110 "Paper Precautions".
Misfeeds occur frequently.	Paper edges are burred when cut in the manufacturing process.	<ul style="list-style-type: none"> • Remove the burrs, for example, with a ruler. • Load paper upside down. • Use clean cut paper with no burrs.
Misfeeds occur frequently.	Printed paper is being used.	Do not load sheets that have already been copied or printed by another printer.
Misfeeds occur frequently.	Sheets are sticking together.	Fan the sheets thoroughly before loading them. Alternatively, feed the sheets into the printer one at a time.
Sheets are feeding in together, resulting in jams.	Sheets are sticking together.	Fan the sheets thoroughly before loading them. Alternatively, feed the sheets into the printer one at a time.
Printed paper becomes creased.	The paper is damp.	Use paper that has been stored in the recommended temperature and humidity conditions. For details about the proper way to

Problem	Cause	Solution
		store paper, see page 110 "Paper Precautions".
Printed paper becomes creased.	The paper is too thin.	Use recommended paper. For details about recommended paper, see page 106 "Paper Size Specifications" and page 108 "Paper Type Specifications".
Edges of sheets are creased.	The paper is damp.	Use paper that has been stored in the recommended temperature and humidity conditions. For details about the proper way to store paper, see page 110 "Paper Precautions".
Edges of sheets are creased.	You are using non-recommended paper.	Use recommended paper. For details about recommended paper, see page 106 "Paper Size Specifications" and page 108 "Paper Type Specifications".
Duplex printing is malfunctioning.	You have selected a paper tray that is not set for duplex print.	Change the setting to enable duplex printing for the paper tray.
Duplex printing is malfunctioning.	You have selected a paper type that cannot be used for duplex printing.	In [Tray Paper Settings], select a paper type that can be used for duplex printing. For details about the paper types that can be used, see page 138 "Printing on Both Sides of a Page".
The image on the back side of duplex printing has mottled blank patches or is smudged.	Missing patches and smudges are caused by moisture leaking from the paper.	<ul style="list-style-type: none"> Do not install the printer in areas that are susceptible to low temperature. Use paper that has been stored in the recommended temperature and humidity conditions. For details about the proper way to store

Problem	Cause	Solution
		paper, see page 110 "Paper Precautions".

Additional Troubleshooting

Problem	Causes	Solutions
<p>The output sheet falls from the output tray.</p> <p>Blocking occurs (the output sheets on the output tray stick together).</p>	<p>Depending on the size, type, or printing conditions of the prints, the output sheets may become badly curled.</p>	<ul style="list-style-type: none"> • Pull out the stop fence of the output tray before printing. • Turn over the stack of paper in the tray. • Remove all output sheets.
<p>It takes a long time to complete a print job.</p>	<p>Photographs and other data intensive pages take a long time for the printer to process, so simply wait when printing such data.</p>	<p>If the Data In indicator is flashing, data has been received by the printer. Wait for a moment.</p> <p>Changing the following settings with the printer driver may help speed up printing:</p> <ul style="list-style-type: none"> • Select [Speed] in "Print Priority" list. • Select a lower resolution. <p>For details about how to change the settings, see the printer driver Help.</p>
<p>Images are printed in the wrong orientation.</p>	<p>The feed orientation you selected and the feed orientation selected in the printer driver's option setup might not be the same.</p>	<p>Set the printer's feed orientation and the printer driver's feed orientation accordingly. For details about settings for printer driver, see the printer driver Help.</p>
<p>Optional components connected to the printer are not recognized.</p>	<p>Bidirectional communication is not working.</p>	<p>Set up optional devices on the properties of the printer. For details about how to set up optional devices, see the printer driver Help.</p>

Problem	Causes	Solutions
Combined printing, booklet printing, or Auto Reduce/Enlarge printing does not come out as expected.	The application or printer driver settings are not configured correctly.	Make sure the application's paper size and orientation settings match those of the printer driver. If a different paper size and orientation are set, select the same size and orientation.
Some types of data, such as graphics data or data from certain applications, do not print.	The printer driver settings are not configured correctly.	<p>PCL 5e/5c</p> <p>On the printer driver's [Print Quality] tab, select [600 dpi] in the "Resolution" area.</p> <p>PCL 6</p> <ul style="list-style-type: none"> • On the printer driver's [Detailed Settings] tab, click [Print Quality] in "Menu:", and then select [Quality] in the "Print Priority:" list. • On the printer driver's [Detailed Settings] tab, click [Print Quality] in "Menu:", and then select [Raster] in the "Vector/Raster:" list. <p>PostScript 3</p> <p>On the printer driver's [Detailed Settings] tab, click [Print Quality] in "Menu:", and then select [Photographic] in the "Dithering:" list.</p> <p>For details about the printer driver settings, see the printer driver Help.</p>
Some characters are not printed or appear strange.	The printer driver settings are not configured correctly.	<p>PCL 5e/5c</p> <p>On the printer driver's [Print Quality] tab, select [600</p>

Problem	Causes	Solutions
		<p>dpi] in the "Resolution" area.</p> <p>PCL 6</p> <ul style="list-style-type: none"> • On the printer driver's [Detailed Settings] tab, click [Print Quality] in "Menu:", and then select [Quality] in the "Print Priority:" list. • On the printer driver's [Detailed Settings] tab, click [Print Quality] in "Menu:", and then select [Raster] in the "Vector/Raster:" list. <p>PostScript 3</p> <p>On the printer driver's [Detailed Settings] tab, click [Print Quality] in "Menu:", and then select [Text] in the "Dithering:" list.</p> <p>For details about the printer driver settings, see the printer driver Help.</p>
Print speed or application relinquishing speed is slow.	The printer driver settings are not configured correctly.	<p>PCL 6</p> <p>On the printer driver's [Detailed Settings] tab, click [Print Quality] in "Menu:", and then select [Speed] in the "Print Priority:" list.</p> <p>For details about the printer driver settings, see the printer driver Help.</p> <p>Quit any other applications.</p>
Print ends mid-job.	An error might have occurred.	Check the printer's display panel to see if an error has occurred.

Problem	Causes	Solutions
A print instruction was issued from the computer, but printing did not start.	User Authentication may have been set.	For details about User Authentication, see Security Guide.
Color originals are printed in black and white.	No color print settings are configured on the printer driver.	Change the "Color/ Black and White:" setting on the printer driver. For details about how to change the "Color/ Black and White:" setting, see the printer driver Help.
PDF files do not print out/ cannot perform PDF direct print.	PDF files are password-protected.	To print password-protected PDF files, enter the password in [PDF Menu].
PDF files do not print out/ cannot perform PDF direct print.	PDF files cannot be printed if they are print-disabled in PDF file security setting.	Change the PDF file security setting.
PDF direct print produces strange or malformed characters.	Fonts were not embedded.	Embed fonts in the PDF file you want to print, and then print.
"Resetting job..." appears and printing is suspended.	Memory is insufficient.	In [System], select [Memory Usage] to [Font Priority].
Printing did not start even though the specified print time has already passed.	[Jobs Not Printed As Machn. Was Off] was set to [Do not Print] in [Printer Features], but at the specified printing time, the main power switch was turned off or the printer was in Low Power Mode.	Set [Jobs Not Printed As Machn. Was Off] to [Prt When Mach On] in [Printer Features]. This function is available for SP C342DN only.
Printing did not start even though the specified print time has already passed.	The time set on the printer or computer is incorrect.	Set the correct time on the printer or computer.
Printing via wireless LAN is slow.	The number of jobs exceeds the capacity of the printer.	Reduce the number of jobs.
Printing via wireless LAN is slow.	<ul style="list-style-type: none"> A communication error might have occurred. 	<ul style="list-style-type: none"> Move the printer farther away from the wireless LAN device.

Problem	Causes	Solutions
	<ul style="list-style-type: none"> • Interference from other wireless LAN devices can reduce the communication speed • If the printer is using a wireless LAN, radio waves may be interfering with the wireless communication. This may occur if there is a microwave oven, cordless telephone, industrial printer, scientific instrument, or medical instrument using the same frequency range near the device. 	<ul style="list-style-type: none"> • If there are active wireless LAN devices nearby, move the printer or disable those devices. • Turn off other printers or instruments that use the same frequency range, and then try printing again. If printing is successful, move the devices to a location where they do not interfere with the printer.

The Printed Image is Different from the Image on the Computer

Problem	Solutions
The printed image is different from the image on the computer's display.	When you use some functions, such as enlargement or reduction, the layout of the image might be different from that displayed on the computer display.
Images are cut off, or excess pages are printed.	<p>If you are using paper smaller than the paper size selected in the application, use the same size paper with that selected in the application. If you cannot load paper of the correct size, use the reduction function to reduce the image, and then print.</p> <p>For details, see the printer driver's Help.</p>
PDF Direct Print is not executed (PDF file is not printed).	<p>You must install an optional hard disk or set the value of [RAM Disk] in the System Menu to 2 MB or higher.</p> <p>For details about [RAM Disk], see:</p> <ul style="list-style-type: none"> • page 234 "System (SP C340DN)" (for SP C340DN) • page 314 "System" (for SP C342DN) <p>When printing a PDF using a password, set the password of the PDF file using the [Change PDF Password] menu in [PDF Menu] or</p>

Problem	Solutions
	<p>Web Image Monitor. For details about [Change PDF Password], see:</p> <ul style="list-style-type: none"> • page 252 "PDF Menu (SP C340DN)" (for SP C340DN) • page 325 "PDF Menu" (for SP C342DN) <p>For details about Web Image Monitor, see Web Image Monitor Help.</p> <ul style="list-style-type: none"> • PDF files not allowed to be printed by the PDF file security setting cannot be printed. • Highly compressed PDFs cannot be printed using PDF Direct Print. Open the relevant application and print the PDF file using the printer driver. Set the file format to standard PDF.
As a result of printing using PDF Direct Printing, characters are missing or misshapen.	Before printing, embed the font in the PDF file to be printed.
The paper size appears on the control panel and printing is not performed with PDF Direct Print.	<p>When PDF Direct Print is used, printout requires paper set within the PDF file. When a message indicating a paper size appears, either place the indicated size in the paper tray or perform Form Feed.</p> <p>Also, if [Sub Paper Size] in the [System] menu is set to [Auto], printing is performed assuming Letter size and A4 size to be the same size. For example, when a PDF file set to A4 size paper is printed using PDF Direct Print and Letter size paper is loaded in the paper tray, or vice versa, the file will be printed out.</p>
The color of the printout is different from the color on the computer's display.	<ul style="list-style-type: none"> • The colors created using color toner are different from the ones displayed on the display. • If you select [On] for [Economy Color:] on the [Print Quality] menu in the printer driver's dialog box, the color gradation may appear differently. <p>For details, see the printer driver's Help.</p> <ul style="list-style-type: none"> • Turn the printer off, and then turn it on again. If the colors are different from what you expect, perform [Color Registration]. <p>For details, see page 440 "Adjusting the Color Registration".</p>
The color of the printout is different from the color specified.	If a specific color is missing turn the printer off, wait a few moments, and then turn it on again. If this does not resolve the problem, contact your sales or service representative.

Problem	Solutions
The color changes significantly when adjusted with the printer driver.	<p>Do not make extreme settings for the color balance on the [Print Quality] menu under the [Detailed Settings] tab in the printer driver's dialog box.</p> <p>Note that the sample image displayed in the printer driver is used only to show what processing will be performed, so it may not match the print results.</p> <p>For details, see the printer driver's Help.</p>
Color documents are printed in black and white.	<ul style="list-style-type: none"> • Color printing is not enabled for the printer. For details, see the printer driver's Help. • Some applications print color files in black and white.
Solid areas, lines, or text are shiny or glossy when created as a mixture of cyan, magenta, yellow.	<ul style="list-style-type: none"> • Select [K (Black)] for [Gray Reproduction:] in the printer driver's dialog box. For details, see the printer driver's Help.
Black gradation is not natural.	<ul style="list-style-type: none"> • Select [CMY + K] for [Gray Reproduction:] in the printer driver's dialog box. For details, see the printer driver's Help.
A color is missing or partially blurred.	<ul style="list-style-type: none"> • Paper is damp. Use paper that has been stored properly. For details, see page 110 "Paper Precautions". • A print cartridge is almost empty. When the "Toner is almost empty." message appears on the display panel. If the toner indicator on the initial screen seems empty, replace the print cartridge of the displayed color. For details, see page 449 "Replacing the Print Cartridge". • Condensation may have collected. If there were sudden changes in temperature or humidity, restart the printer when it is acclimatized.

When Printer Is Not Functioning Properly

Problem	Solutions
Paper is not fed from the selected tray.	<p>When you are using a Windows operating system, the printer driver settings override those set using the control panel. Set the input tray you want using the printer driver.</p> <p>For details, see the printer driver's Help.</p>
Prints do not stack properly.	<ul style="list-style-type: none"> • Paper is damp. Use paper that has been stored properly. See page 110 "Paper Precautions". • If printed sheets come out curled, use the standard tray extension. See page 14 "Guide to Components".
It takes too long to turn on the printer.	<p>If the printer is turned off while accessing the hard disk (for example: during file deletion), the printer will require more time to power-up the next time it is turned on. To avoid this time delay, do not turn the printer off while it is in operation.</p>
It takes too long to resume printing.	<ul style="list-style-type: none"> • The data is so large or complex that it takes time to process it. If Data In indicator is flashing, the data is being processed. Wait until it resumes. • The printer was in the Energy Saver mode or the Sleep mode. To recover from these modes, the printer must warm up, and this takes time until printing starts. For details, see page 74 "Saving Energy".
It takes too long to complete the print job.	<ul style="list-style-type: none"> • Photographs and other data-intensive pages take a long time for the printer to process, so wait when printing such data. Changing the settings with printer driver may help to speed up printing. For details, see the printer driver's Help. • The data is so large or complex that it takes time for the printer to process it. If Data In indicator is flashing, the data is being processed. Wait until it resumes. • If "Waiting for print data..." appears on the display, the printer is now warming up. Wait for a while. The printer is adjusting the color registration. Wait for a while.
Attached options are not detected in the printer properties.	<p>The computer and printer are not in bidirectional communication. You must configure attached options in the printer properties. For details, see the printer driver's Help.</p>

Problem	Solutions
When printing combined prints or bound prints.	<p>Check that the paper size and direction set in the printer driver are the same as those set in the application.</p> <p>If the settings are not the same, change the settings of the printer driver.</p>
An empty tray is selected by Auto Tray Select, and the document is not printed due to out of paper error.	<p>If a paper tray is opened and closed while the printer is in Energy Saver mode, the printer will initialize the tray upon recovery, but the tray will not be selectable by Auto Tray Select.</p> <p>To print from a paper tray that you opened and closed while the printer was in Energy Saver mode, you must manually specify the tray as the source paper tray before printing. When the printer recovers from Energy Saver mode and completes initialization, it will then print the document from the tray you have specified.</p>

When PictBridge Printing Does Not Work

Problem	Causes	Solutions
PictBridge is not available.	There is a problem with the USB connection or the PictBridge settings.	Use the following procedure to check the connection and settings: <ol style="list-style-type: none"> 1. Disconnect, and then reconnect the USB cable. 2. Check that the PictBridge settings are enabled. 3. Disconnect the USB cable, and then turn off the printer. Turn the printer back on. When the printer has fully booted up, reconnect the USB cable.
When two or more digital cameras are connected, the second and subsequent cameras are not recognized.	You have connected multiple digital cameras.	Connect only one digital camera. Do not connect multiple cameras.
Printing is disabled.	The number of originals exceeds the maximum number of pages that can be printed at a time.	The maximum specifiable print quantity at a time is 999. Respecify the quantity to 999 or less, and then retry printing.
Printing is disabled.	There is no paper of the specified size remaining.	There is no paper of the specified size remaining. If you have to use paper that is not of the specified size, perform Form Feed. To cancel printing, perform Job Cancel.
Printing is disabled.	The paper size setting for this tray cannot be printed on the printer.	Select the paper size setting that can be printed on the printer.

Removing Jammed Paper

An error message appears if a paper misfeed occurs. The error message indicates where the misfeed occurs.

Check the location and remove the paper.

⚠ CAUTION

- The inside of the machine could be very hot. Do not touch the parts with a label indicating the "hot surface." Otherwise, an injury might occur.
- Some of this machine's internal components get very hot. For this reason, take care when removing misfed paper. Not doing so could result in burns.
- When removing jammed paper, make sure not to trap or injure your fingers.

★ Important

- To prevent misfeeds, do not leave any torn scraps of paper inside the printer.
- Contact your service representative if misfeeds occur frequently.
- If the error message remains displayed even after you remove misfed paper, open and close the front cover.

6

Paper Misfeed Message (A)

1. Pull the front cover open lever, and then open the front cover with both hands carefully.

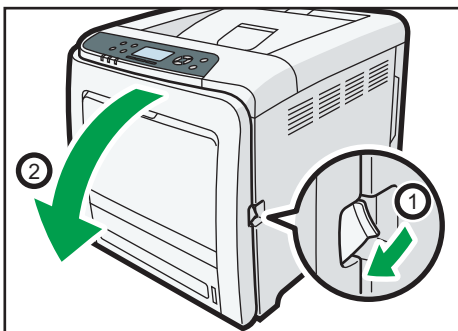

DPP058

2. Carefully pull the jammed paper upward and out.

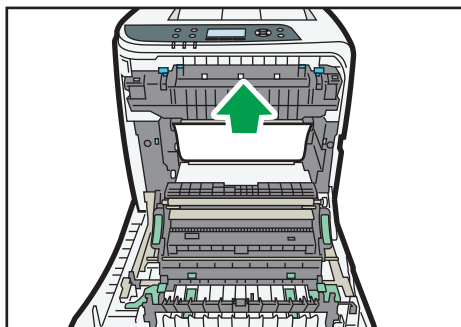

DPP059

If paper has jammed inside the paper transfer unit, holding both sides of the paper, pull the paper carefully forward and out.

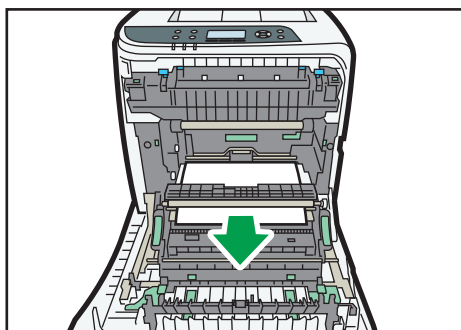

DPP060

3. Close the front cover with both hands carefully.

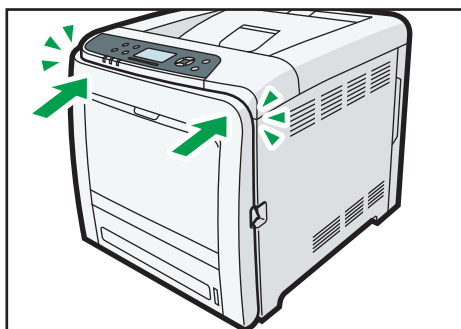

DPP061

Note

- Do not pull out the paper tray (Tray 1).
- If paper is jammed in Tray 2, but it is difficult to locate, pull out Tray 2 to remove it. After removing the paper, carefully push Tray 2 all the way back inside the printer.
- When closing the front cover, push the upper side of the cover firmly. After closing the cover, check that the error is cleared.

Misfeed Bypass Tray

1. Remove paper loaded in the bypass tray, and then close the bypass tray with both hands.

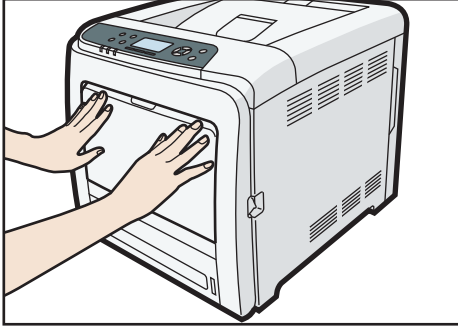

DPP062

2. Pull Front Cover Open Lever, and then open the front cover with both hands carefully.

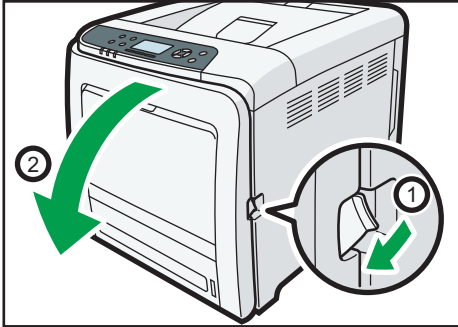

DPP058

3. Pull out the jammed paper carefully.

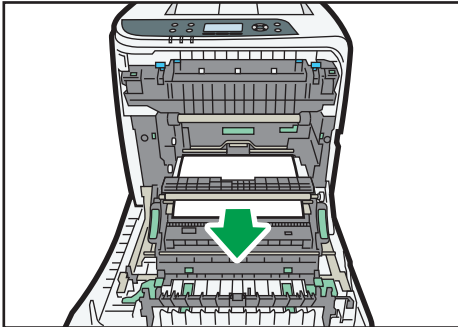

DPP060

4. Close the front cover with both hands carefully.



DPP062

↓ Note

- Be sure the Tray 1 is inserted before you open the front cover.
- When closing the front cover, push the upper side of the cover firmly. After closing the cover, check that the error is cleared.

Paper Misfeed Message (B)

6

★ Important

- The inside of this printer becomes very hot. Before removing paper around the fusing unit, wait until the temperature of the covers inside the fusing unit and paper transfer unit cools down.

1. Pull the front cover open lever, and then open the front cover with both hands carefully.

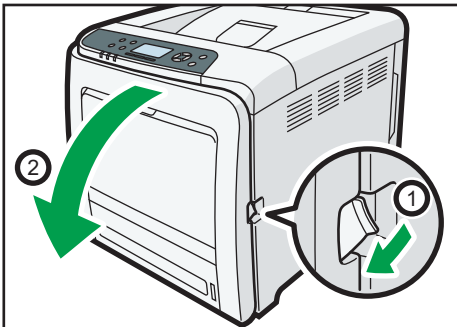

DPP058

2. Lower the blue fusing unit levers, and pull out the jammed paper carefully.

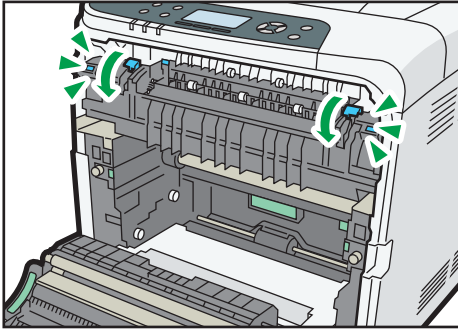

DPP063

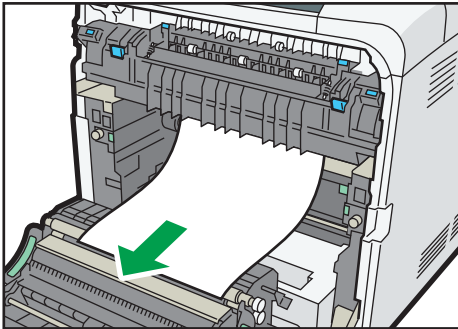

DPP064

Pull the paper downward to remove it. Do not pull it upward.

If the jammed paper is visible in the output tray, lower the blue fusing unit levers, and then pull the jammed paper out of the tray.

If you cannot find the jammed paper, open the guide by lowering the guide's blue levers. Check inside the guide for the jammed paper.

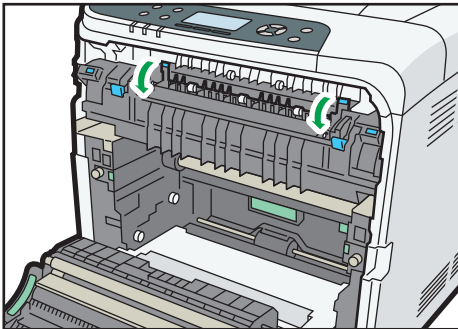

DPP065

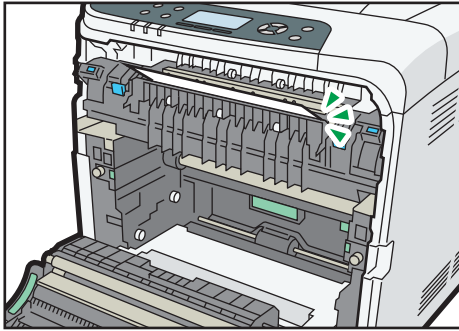

DPP066

Be sure to fully close the guide after you have checked inside it for jammed paper.

Attempting to close the front cover when the guide is still open will damage one or both of these components.

3. Close the front cover with both hands carefully.

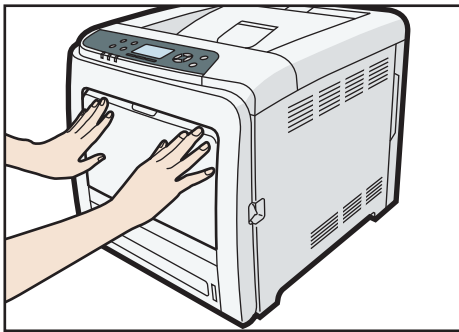

DPP062

Note

- When closing the front cover, push the upper side of the cover firmly. After closing the cover, check that the error has cleared.

Paper Misfeed Message (Y)

zzz

Paper Misfeed Message (Z)

1. Pull the front cover open lever, and then open the front cover with both hands carefully.

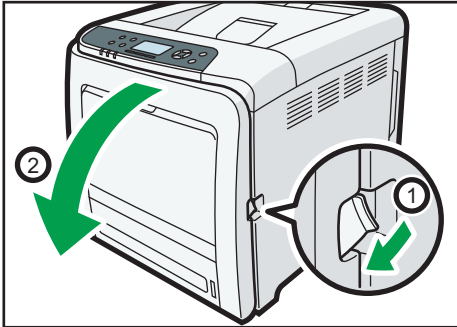

DPP058

2. Carefully remove jammed paper under the paper transfer unit.

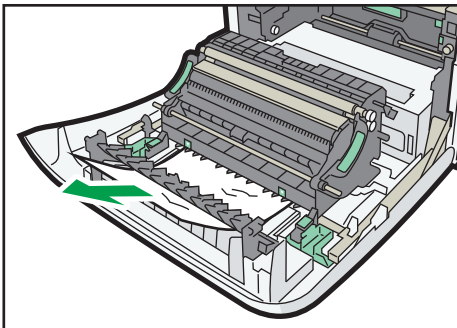

DPP067

3. Close the front cover with both hands carefully.

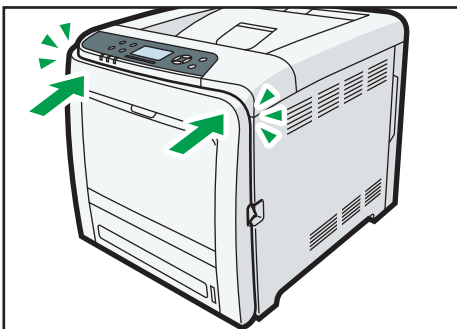

DPP061

Note

- When closing the front cover, push the upper side of the cover firmly. After closing the cover, check that the error has cleared.

7. Maintenance and Specifications

This chapter explains how to replace supplies and clean this printer. It also describes the specifications of this printer and its options.

General Requirements

This section describes notes, cautions, and warnings user must check while using this printer.

Precautions

WARNING

- Do not place vases, plant pots, cups, toiletries, medicines, small metal objects, or containers holding water or any other liquids, on or close to this machine. Fire or electric shock could result from spillage or if such objects or substances fall inside this machine.

- Do not use flammable sprays or solvents in the vicinity of this machine. Also, avoid placing these items in the vicinity of this machine. Doing so could result in fire or electric shock.

CAUTION

- Do not obstruct the machine's vents. Doing so risks fire caused by overheated internal components.

- Keep the machine away from humidity and dust. Otherwise a fire or an electric shock might occur.
- Do not place the machine on an unstable or tilted surface. If it topples over, an injury might occur.

- Make sure the room where you are using the machine is well ventilated and spacious. Good ventilation is especially important when the machine is used heavily.

Important

- The area around the ventilation holes might be warm. This is caused by exhaust air and is not a malfunction.
- If the printer is moved from a cold to a warm place, condensation may be formed inside. After moving the printer, do not use it for at least two hours, so that it can be adapted to its new environment.
- Do not turn the printer off while it is in operation.
- Do not open the printer covers while the printer is working. Otherwise, a misfeed might occur.

- Do not move or tilt the printer when the power is on.
- Do not subject the printer to shock or impact while it is operating.
- Depending on the ambient temperature and humidity, steam may come from the ventilation holes behind the control panel during printing. This is water vapor from the paper, not a sign of malfunction.

Ventilation

When you use this machine in a confined space without good ventilation for a long time or print large quantities, you might detect an odd smell.

This might cause the output paper to also have an odd smell.

When you detect an odd smell, regularly ventilate in order to keep the workplace comfortable.

- Set up the machine so that it does not directly ventilate towards people.
- Ventilation should be more than 30 m³/hr/person.

New machine smell

When a machine is new, it might have a unique smell. This smell will subside in about one week.

When you detect an odd smell, sufficiently ventilate and circulate the air in the room.

Saving Printouts

- Prints will fade if exposed to strong light or dampness and humidity for lengthy periods. Preserve the quality of your prints by storing them in a binder in a dark, dry place.
- Toner may melt if a print and a half-dried print are put on top of each other.
- Toner may also melt if solvent type adhesive agents are used for pasting prints.
- If prints are folded, toner in the folds will come off.
- Toner may melt if it is placed on mats made of chlorinated plastic in locations of high temperature for long periods of time.
- Toner may melt if prints are placed in places of extremely high temperatures, such as near heaters.

Backing Up Hard Disk Data

This function is available for SP C342DN only.

You can store Address Book information on the printer's hard disk. To back up the printer's Address Book, use SmartDeviceMonitor for Admin/Device Manager NX Lite or Web Image Monitor.

For details, see the manual for SmartDeviceMonitor for Admin/Device Manager NX Lite. For details about Web Image Monitor, see Web Image Monitor Help.

★ Important

- Avoid strong impact to the printer. Doing so may damage the hard disk.
- When turning off the power or disconnecting the power cord, follow the proper procedures. Not doing so may damage the hard disk. For details about how to turn off the power, see page 73 "Turning On/Off the Power".
- If the printer's hard disk breaks data including Address Book information might be lost. For this reason, do not save important data on the printer's hard disk without backing it up or downloading it. We also recommend backing up fonts, forms, and any other downloaded resources that are stored on the hard disk. The manufacturer is not liable for damages resulting from data loss.

Moving the Printer

This section describes precautions to move the printer.

Choose your printer's location carefully. Environmental conditions greatly affect the printer's performance.

WARNING

- It is dangerous to handle the power cord plug with wet hands. Doing so could result in electric shock.

CAUTION

- Unplug the power cord from the wall outlet before you move the machine. While moving the machine, take care that the power cord is not damaged under the machine. Failing to take these precautions could result in fire or electric shock.
- When disconnecting the power cord from the wall outlet, always pull the plug, not the cord. Pulling the cord can damage the power cord. Use of damaged power cords could result in fire or electric shock.
- The printer weighs approximately 29/30 kg (63.9/66.1 lb.). When moving the printer, use the inset grips on both sides, and lift slowly in pairs. The printer will break or cause injury if dropped.

Important

- **Be careful when moving the printer. Take the following precautions:**
 - Turn off the main power. For details about how to turn the main power off, see page 73 "Turning On/Off the Power".
 - Close all covers and trays, including the front cover and bypass tray.
 - If optional paper feed units are attached, remove them from the printer and move them separately.
 - Be sure to place the printer on a smooth and stable place.
 - Keep the printer level and carry it carefully, taking care not to jolt or tip it. Rough handling may cause a malfunction or damage the hard disk or memory, resulting in loss of stored files.
 - Protect the printer from strong shocks. Impact can damage the hard disk and cause stored files to be lost. As a precautionary measure, files should be copied to another computer.
- 1. **Be sure to check the following:**
 - The main power switch is turned off.
 - The power cord is unplugged from the wall outlet.
 - The interface cable is unplugged from the printer.

2. If any external options are attached, remove them.

See the relevant sections in this manual and refer to the steps to remove options.

3. Lift the printer by using the inset grips on both side of the printer, and then move it horizontally to the place where you want to install it.

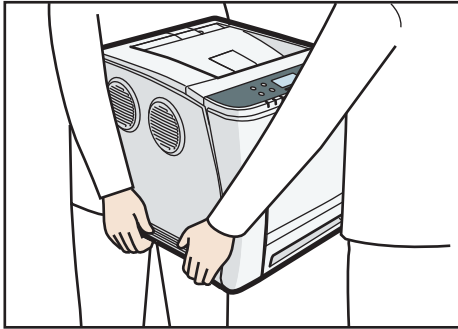

DFP068

4. If you removed options, reattach them.

For details, see the relevant sections in this manual.

Note

- Be sure to move the printer horizontally. To prevent toner from scattering, move the printer slowly.

Cleaning the Printer

This section explains how to clean the printer.

Precautions When Cleaning the Printer

★ Important

- Do not use chemical cleaners or organic solvents, such as thinner or benzene. If such substances get inside the printer or melt plastic parts, a failure might occur.
- Do not clean parts other than those explicitly specified in this manual. Other parts should only be cleaned by your service representative.

When cleaning the printer, wipe the printer with a soft, dry cloth. If this does not remove the dirt, wipe the printer with a damp and tightly wrung cloth. If a damp cloth still does not remove the dirt, try using a mild detergent. Wipe the printer with a dry cloth to remove the moisture after using a damp cloth.

Cleaning the Paper Tray, Friction Pad, and the Paper Feed Roller

7

If the paper tray, friction pad, or paper feed roller is dirty, a multi-feed or misfeed might occur. Clean these parts by following the cleaning procedure for Tray 1 described below. The cleaning procedure is the same for the optional paper feed units.

1. Turn off the printer and unplug the power cord.
2. Pull out the plug from the socket. Remove all the cables from the printer.
3. Pull the tray carefully until it stops, lift the front side of the tray, and then pull it out of the printer.

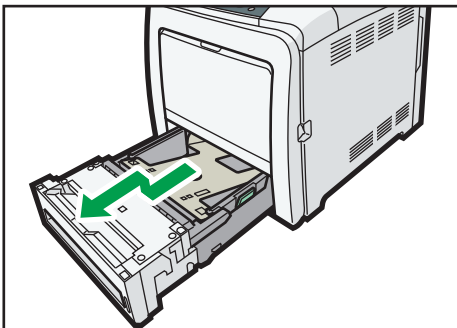

DPP042

Place the tray on a flat surface.

4. If there is paper in the tray, remove the paper.

5. Wipe the areas indicated in the illustrations below using a dry or damp cloth.

- Friction pad

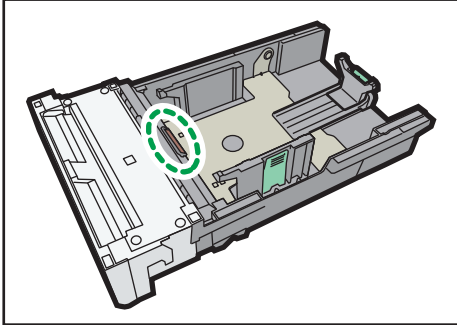

DPP069

Use only a dry cloth to clean the friction pad.

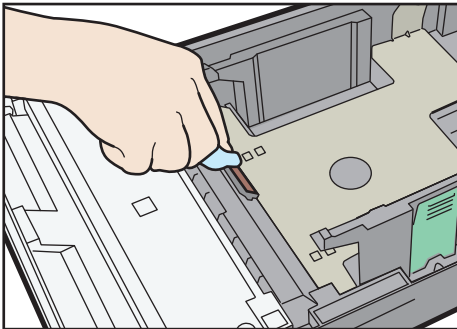

DPP070

- Paper tray

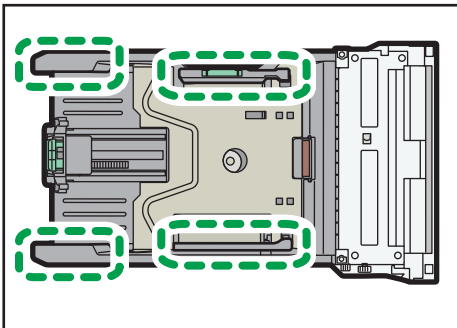

DPP071

- Paper feed roller

Wipe around the paper feed roller by turning it with a damp cloth. Then, wipe it with a dry cloth to remove any water.

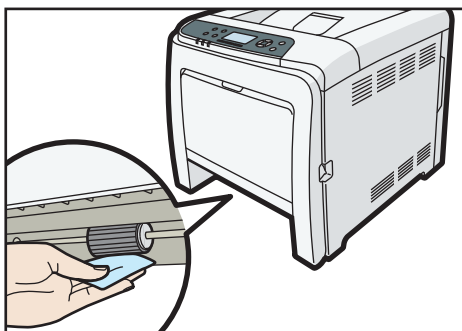

DPP072

After that, wipe it with a dry cloth to remove the water.

6. Push the metal plate down until it clicks into place to lock.

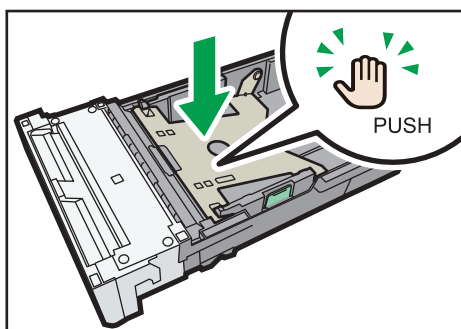

DPP043

7. Load the removed paper stack in the tray.
8. Lift the front side of the tray, and then slide it into the printer carefully until it stops.

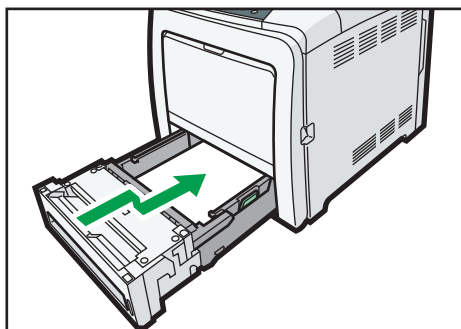

DPP047

Do not slide the paper tray in forcefully. Otherwise, the front and side guides might move.

9. Firmly insert the plug of the power cord into the wall socket. Connect all the interface cables that were removed.
10. Turn the main power switch on.

Cleaning the Registration Roller

When you use paper other than the standard types, specks of paper may stick on the registration roller, causing problems. Clean the registration roller if white dots appear on prints.

Clean the registration roller if printed paper becomes smeared after a paper jam is cleared.

⚠ CAUTION

- The inside of the machine could be very hot. Do not touch the parts with a label indicating the "hot surface". Otherwise, an injury might occur.

★ Important

- Do not use chemical cleaners or organic solvents such as thinners or benzene.
1. Turn off the printer and unplug the power cord.
 2. Pull out the plug from the socket. Remove all the cables from the printer.
 3. Pull the front cover open lever, and then open the front cover with both hands carefully.

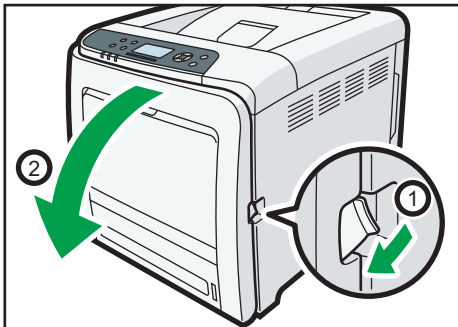

DPP058

The registration roller is set in the position shown by the illustration.

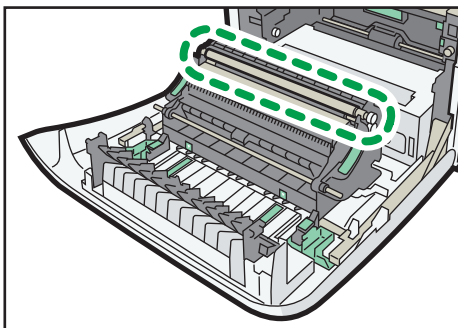

DPP073

Do not touch the registration roller.

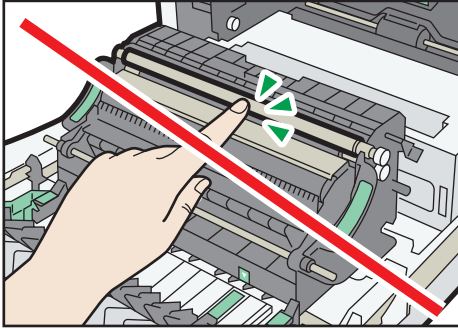

DPP074

4. Using a cloth, wipe the rubber registration roller.

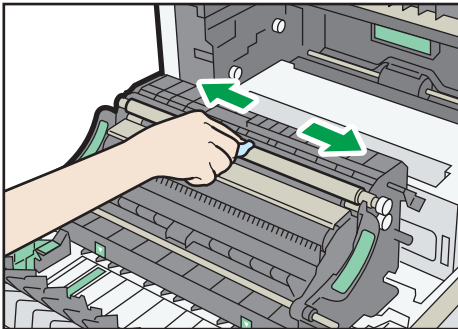

DPP075

5. Close the front cover with both hands carefully.

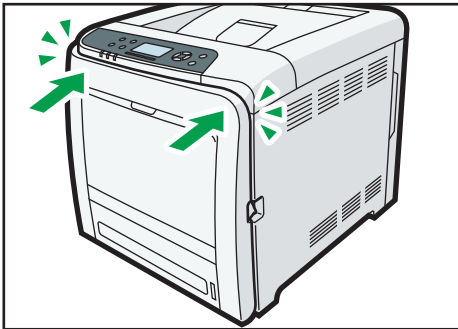

DPP061

6. Firmly insert the plug of the power cord into the wall socket. Connect all the interface cables that were removed.
7. Turn on the main power switch.

Cleaning the Toner Density Sensor

1. Turn off the printer and unplug the power cord.

2. Pull the top cover open lever upward to open the top cover.

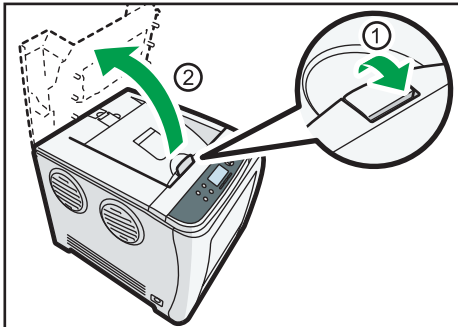

DFP009

3. Lift out the cyan print cartridge.

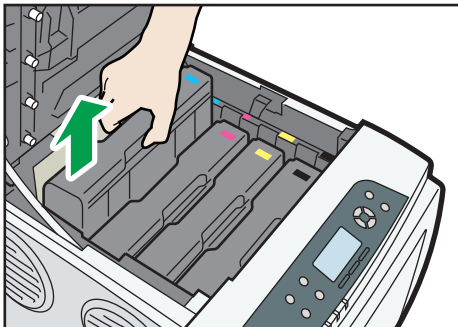

DFP076

4. Slide the toner density sensor lever once to the left.

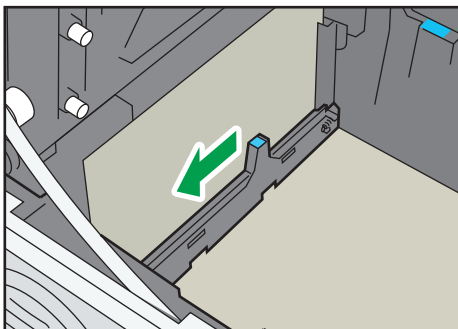

DFP077

Slide the lever only once.

5. To reattach the cyan print cartridge removed in step 2. Push it all the way in carefully.

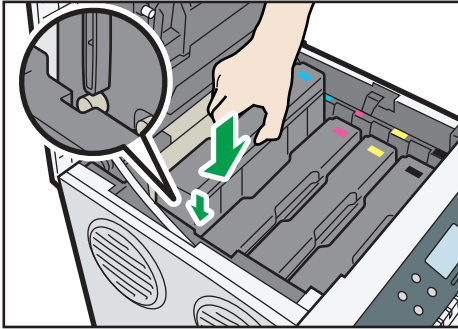

DFP078

6. Close the top cover with both hands carefully. Be careful not to trap your fingers.

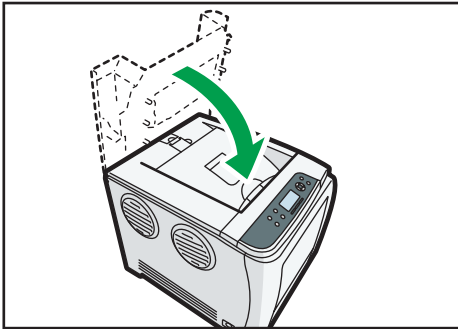

DFP015

Cleaning the Power Cord Plug

To clean the power cord plug, wipe the plug with a soft, dry cloth with the power cord connected to the printer.

⚠ WARNING

- Be sure to disconnect the plug from the wall outlet at least once a year and check for the following:
 - There are burn marks on the plug.
 - The prongs on the plug are deformed.
- If any of the above conditions exist, do not use the plug and consult your dealer or service representative. Use of the plug could result in fire or electric shock.

- Be sure to disconnect the power cord from the wall outlet at least once a year and check for the following:
 - The power cord's inner wires are exposed, broken, etc.
 - The power cord's coating has a crack or dent.

⚠ WARNING

- When bending the power cord, the power turns off and on.
- Part of the power cord becomes hot.
- The power cord is damaged.
- If any of the above conditions exist, do not use the power cord and consult your dealer or service representative. Use of the power cord could result in fire or electric shock.

⚠ CAUTION

- When disconnecting the power cord from the wall outlet, always pull the plug, not the cord. Pulling the cord can damage the power cord. Use of damaged power cords could result in fire or electric shock.
- Be sure to disconnect the plug from the wall outlet and clean the prongs and the area around the prongs at least once a year. Allowing dust to build up on the plug constitutes a fire hazard.

★ Important

- Turn off the main power switch before unplugging the power cord. See page 73 "Turning On/Off the Power".

Adjusting the Color Registration

After moving the printer, printing on thick paper, or printing repeatedly for some time, color degradation may occur. By performing automatic color adjustment, you can restore optimum print quality.

SP C340DN

Press the [Menu] key, and then select the setting items using the [▼] or [▲] key.

1. Select [Maintenance] ▶ Press [OK]
2. Select [Quality Maintenance] ▶ Press [OK]
3. Select [Color Registration] ▶ Press [OK]
4. Select [Auto Adjust] ▶ Press [OK]
5. Press [OK]

Automatic color adjustment begins.

Auto color registration takes about 30 seconds.

A confirmation message appears when the adjustment is complete.

6. Press [Exit]

SP C342DN

1. Press the [User Tools] key, and then adjust the color registration.

[Maintenance: Image] ▶ [Color Registration] ▶ [Start]

Automatic color adjustment begins.

Auto color registration takes about 30 seconds.

A confirmation message appears when the adjustment is complete.

2. Press [Exit]

Correcting the Color Gradation

Color gradation during color printing changes depending on a number of factors. If you print the same file repeatedly or toner was recently replaced, changes may occur in color tones. In such cases, you can obtain optimal print results by correcting the color gradation.

Two methods are available for color gradation correction: automatic correction and manual correction by printing a gradation correction sheet. Perform a manual correction if you are not satisfied with the quality of output after an automatic correction.

↓ Note

- Color gradation correction is not required under normal circumstances.
- If a printer is not used for some time, changes may occur in color tones.
- If suitable results cannot be obtained after a single correction, repeat the correction several times as needed.
- Corrections to color gradation will be applied to all user jobs.
- To check gradation corrections, use the same type of paper. If a different type of paper is used, corrections may not be reflected.

Density gradation from midtones to highlights can be corrected automatically by executing the automatic gradation correction function.

Corrections will be applied to each resolution setting. If color tones change when different resolutions are selected in the printer driver, perform the gradation correction for the resolution you want to use.

Resolution setting in the printer driver	Value specified for automatic gradation correction
600 × 600 dpi	600 × 600 dpi (1 bit)
2400 × 600 dpi equivalent	600 × 600 dpi (2 bit)
1200 × 1200 dpi*	1200 × 1200 dpi (1 bit)*

* zzz

Flow of Manual Gradation Correction

Manual Gradation Correction is performed in the following order:

1. **Print gradation correction sheet 1.**
2. **Adjust the parts of highlight colors.**

Set the correction value.

Print the gradation correction sheet, and then check the correction result.

3. Print gradation correction sheet 2.

Adjust the parts of middle colors.

Set the correction value.

Print the gradation correction sheet, and then check the correction result.

4. Save the correction value.

Gradation Correction Sheet

Reading the gradation correction sheet

The printed gradation correction sheet is read as shown below:

While comparing the gradation correction sheet and correction value of each color, K (black), M (magenta), and C (cyan)/Y (yellow) determine the required gradation correction and configure the settings using the control panel.

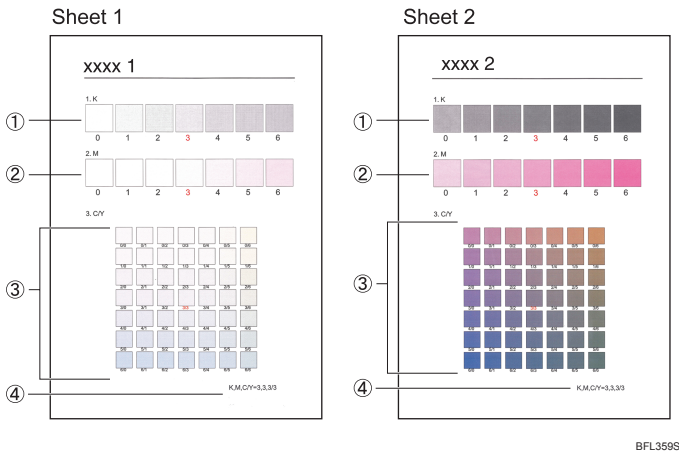

1. K (black) correction value

Adjusts the color printed when only black toner is used. The currently set correction value is printed in red.

2. M (magenta) correction value

Adjusts the color printed when only magenta toner is used. The currently set correction value is printed in red.

3. C (cyan)/Y (yellow) correction value

Corrects the colors printed when cyan and yellow are used. For C/Y (cyan/yellow), the correction value is determined based on a combination of these two colors, although panel settings are configured for each color.

4. Setting value

The value displayed is the one currently set when the gradation correction sheet is printed. This value matches the one set on the control panel.

Setting Gradation Correction Values

Correct the gradation in two areas: bright areas (highlights), and medium areas (midtones). [Print Test Pattern 1] or [Print Test Pattern 1 for Calibration] is used to set the correction value for highlights, and [Print Test Pattern 2] or [Print Test Pattern 2 for Calibration] is used for mid tones.

SP C340DN

Press the [Menu] key, and then select the setting items using the [▼] or [▲] key.

1. Select [Maintenance] ▶ Press [OK]
2. Select [Quality Maintenance] ▶ Press [OK]
3. Select [Color Calibration] ▶ Press [OK]
4. Select [Adj.Auto Dens.] ▶ Press [OK]

A confirmation message appears. Press [OK] to adjust Auto Density.

A confirmation message appears when the adjustment is complete. Press [Exit].

The display returns to the [Color Calibration] screen.

5. Select [Print Test Pattern 1] ▶ Press [OK]
6. Press [Print].
7. Compare the colors printed on gradation correction sheet 1 with the colors you want to reproduce.

When the selected sheet is printed, a confirmation message will appear.

8. Press [Continue].
9. Select the color you want to adjust ▶ Press [OK]
10. Adjust the correction value ▶ Press [OK]
11. Press [Result].
12. Press [Print].
13. Check the result by printing the calibration sheet.
14. Press [Yes].
15. Select [Print Test Pattern 2] ▶ Press [OK]

Adjust the midtones on gradation correction sheet 2 by repeating the procedure you used to adjust the color values on gradation correction sheet 1.

SP C342DN

1. Press the [User Tools] key, and then correct the gradation.

[Maintenance: Image] ▶ [Color Calibration] ▶ [Adjust Auto Density] ▶ [Start]

The confirmation message appears when complete. Press [Exit].

2. Print the selected sheet, and then correct the gradation.

[Print Test Pattern 1 for Calibration] or [Print Test Pattern 2 for Calibration] ▶ Select the color you want to adjust ▶ Adjust the correction value for the selected color ▶ [OK]

Enter the value between 0 and 6.

3. Check the result by printing the calibration sheet, and then save the settings.

[Print Result] ▶ [Yes]

Resetting the Gradation Correction Value to the Default Value

SP C340DN

Press the [Menu] key, and then select the setting items using the [▼] or [▲] key.

1. Select [Maintenance] ▶ Press [OK]
2. Select [Quality Maintenance] ▶ Press [OK]
3. Select [Color Calibration] ▶ Press [OK]
4. Select [Reset] ▶ Press [OK]
5. Press [Yes]

SP C342DN

1. Press the [User Tools] key, and then reset the gradation correction value to the default value.

[Maintenance: Image] ▶ [Color Calibr.] ▶ [Reset Setting] ▶ [OK]

The confirmation message appears when complete. Press [Exit].

Adjusting Printing Position

You can adjust the printing position. Normally you do not need to update the printing position. However, updating is useful in some cases when the optional paper feed unit is installed.

"Horizontal" paper is perpendicular to the feed direction. "Vertical" means paper is parallel to the paper feed direction.

SP C340DN

Press the [Menu] key, and then select the setting items using the [▼] or [▲] key.

1. Select [Maintenance] ▶ Press [OK]
2. Select [Quality Maintenance] ▶ Press [OK]
3. Select [Registration] ▶ Press [OK]
4. Select [Prt.Test Sheet] ▶ Press [OK]
5. Select the tray you want to adjust ▶ Press [OK]
6. Print the test sheet to preview the settings.

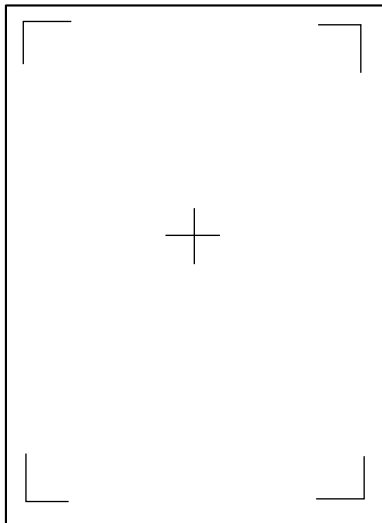

Use this sheet to check the current print position.

7. Press the [Escape] key until the screen returns to the [Registration] menu.
8. Select [Adjustment] ▶ Press [OK]
9. Select the tray and feed direction you want to adjust ▶ Press [OK]

10. Enter to change the registered value (mm) ▶ Press [OK]

Increase the value to move the print area in the direction indicated by the "+" symbol in the diagram below. Decrease the value to move the print area in the direction indicated by the "-" symbol.

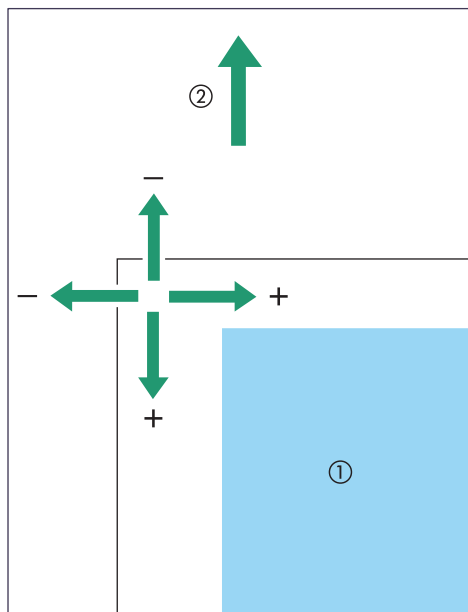

①: Print Area

②: Paper Feed Direction

11. Print the test sheet to check the adjustment result.**SP C342DN****1. Press the [User Tools] key, and then print the test sheet.**

[Maintenance: Image] ▶ [Adjust Print Position] ▶ [Print Test Sheet] ▶ Select the tray you want to adjust

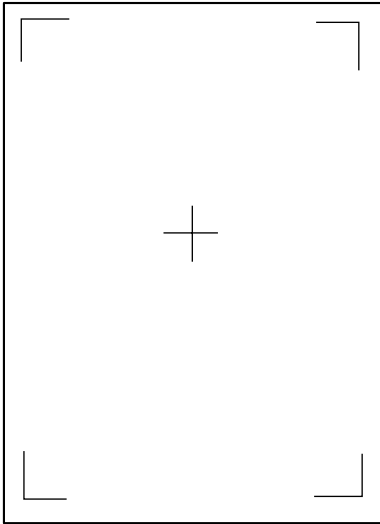
2. Print the test sheet to preview the settings.

Use this sheet to check the current print position.

3. Press [Exit].**4. Adjust the printing position.**

[Adjust Position] ▶ Select the tray you want to adjust ▶ Enter to change the registered value (mm) ▶ [OK] ▶ [Exit]

Increase the value to move the print area in the direction indicated by the "+" symbol in the diagram below. Decrease the value to move the print area in the direction indicated by the "-" symbol.

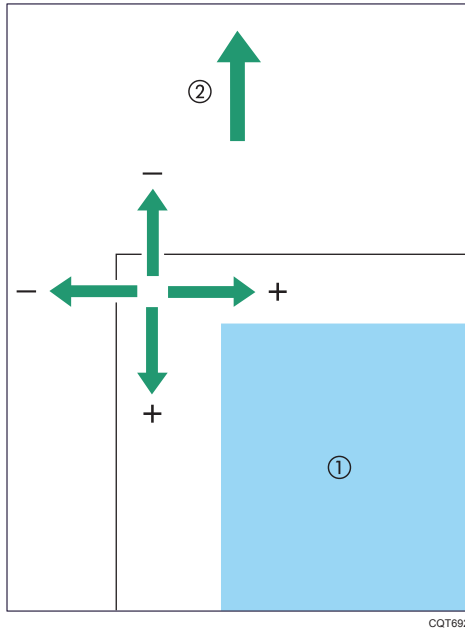

①: Print Area

②: Paper Feed Direction

Replenishing and Replacing Consumables

This section explains how to replenish consumables when they run out.

Replacing the Print Cartridge

This section explains precautions to add toner when it has run out, and how to dispose of used toner.

WARNING

- Do not incinerate toner (new or used) or toner containers. Doing so risks burns. Toner will ignite on contact with naked flame.
- Do not store toner (new or used) or toner containers anywhere near naked flames. Doing so risks fire and burns. Toner will ignite on contact with naked flame.
- Do not use a vacuum cleaner to remove spilled toner (including used toner). Absorbed toner may cause a fire or explosion due to electrical contact flickering inside the vacuum cleaner. However, it is possible to use a vacuum cleaner that is explosion-proof and dust ignition-proof. If toner is spilled on the floor, remove the spilled toner slowly using a wet cloth, so that the toner is not scattered.

CAUTION

- Do not crush or squeeze toner containers. Doing so can cause toner spillage, possibly resulting in dirtying of skin, clothing, and floor, and accidental ingestion.
- Store toner (new or used), toner containers, and components that have been in contact with toner out of reach of children.
- If toner or used toner is inhaled, gargle with plenty of water and move into a fresh air environment. Consult a doctor if necessary.
- If toner or used toner gets into your eyes, flush immediately with large amounts of water. Consult a doctor if necessary.
- If toner or used toner is swallowed, dilute by drinking a large amount of water. Consult a doctor if necessary.
- When removing jammed paper or replacing toner, avoid getting toner (new or used) on your clothing. If toner comes into contact with your clothing, wash the stained area with cold water. Hot water will set the toner into the fabric and make removing the stain impossible.

⚠ CAUTION

- When removing jammed paper or replacing toner, avoid getting toner (new or used) on your skin. If toner comes into contact with your skin, wash the affected area thoroughly with soap and water.

★ Important

- Actual printable numbers vary depending on image volume and density, number of pages printed at a time, paper type and size, and environmental conditions such as temperature and humidity. Toner quality degrades over time. Early replacement of the print cartridge might be necessary. Therefore, we recommend you always keep a new print cartridge ready.
- The print cartridge might need to be replaced even if there is toner remaining in it. This is due to depletion or wear of other components.
- Do not allow paper clips, staples, or other small metallic objects to fall inside the printer.
- Do not expose the print cartridge without its cover to direct sunlight for a long time.
- When removing print cartridge, be careful not to drop it.
- Store print cartridges in a cool dark place.

- SP C340DN:

For details about installing the toner, see the instructions on the package of the toner.

- SP C342DN:

Replace the print cartridge when the following message appears on the display. Follow the instruction on the screen regarding how to replace the print cartridge.

Replace the print cartridge when the following messages appear on the display:

- SP C340DN:

" Out of toner"

- SP C342DN:

"No toner. Replace Toner Cartridge."

"No color toner. Color toner is required to print in black & white with the current paper type. Replace the color Print Cartridge or press [Job Reset] to cancel printing."

When the following messages appear on the display, the toner has almost run out. Have a replacement print cartridge at hand.

- SP C340DN:

" Toner is almost empty."

- SP C342DN:

"Toner Cartridge is almost empty. Replace Toner Cartridge."

Note

- If print cartridge are not changed when necessary, printing will become impossible. We recommend keeping a stock of print cartridge.
- Print cartridge (consumables) are not covered by warranty. However, if there is problem, contact the store where they were purchased.

Replacing Other Consumables

Refer to the maintenance guide provided with the new items for the replacement.

⚠ WARNING

- Do not use a vacuum cleaner to remove spilled toner (including used toner). Absorbed toner may cause a fire or explosion due to electrical contact flickering inside the vacuum cleaner. However, it is possible to use a vacuum cleaner that is explosion-proof and dust ignition-proof. If toner is spilled on the floor, remove the spilled toner slowly using a wet cloth, so that the toner is not scattered.

⚠ CAUTION

- Store toner (new or used), toner containers, and components that have been in contact with toner out of reach of children.
- If toner or used toner is inhaled, gargle with plenty of water and move into a fresh air environment. Consult a doctor if necessary.
- If toner or used toner gets into your eyes, flush immediately with large amounts of water. Consult a doctor if necessary.
- If toner or used toner is swallowed, dilute by drinking a large amount of water. Consult a doctor if necessary.
- When removing jammed paper or replacing toner, avoid getting toner (new or used) on your clothing. If toner comes into contact with your clothing, wash the stained area with cold water. Hot water will set the toner into the fabric and make removing the stain impossible.
- When removing jammed paper or replacing toner, avoid getting toner (new or used) on your skin. If toner comes into contact with your skin, wash the affected area thoroughly with soap and water.

CAUTION

- The fusing unit becomes very hot. When installing a new fusing unit, turn off the printer and wait at least an hour after power off before replacing parts. Not allowing the printer to cool may result in burns.

Important

- **Replace the intermediate transfer unit and transfer roller together.**
- **When installing the waste toner bottle and the intermediate transfer unit, do not tilt, turn upside down, or shake it.**

Waste toner bottle

Replace the waste toner bottle when the following message appears on the display:

- SP C340DN
 "Waste Toner Bottle full"
- SP C342DN
"Waste Toner Bottle is full. Replace the bottle."

When the following message appears on the display, the waste toner bottle should be replaced soon.

- SP C340DN
 "Waste Toner almost full"
- SP C342DN
"Waste Toner Bottle is almost full. A new Waste Toner Bottle is required. Please contact your local vendor."

Intermediate transfer unit

Replace the intermediate transfer unit when the following message appears on the display:

- SP C340DN
"Replacemnt Requird: IntTrans"
- SP C342DN
"Replacement of Transfer Unit is now necessary. Please call service."

When the following message appears on the display, the intermediate transfer unit should be replaced soon.

- SP C340DN
"Replcmnt Rqrd Soon: IntTrans"
- SP C3432DN
"Replacement of Transfer Unit will soon be necessary. A new unit is required. Please contact your local vendor."

Maintenance Kit

Replace the Maintenance Kit when the following messages appear on the display:

- SP C340DN
"Replacmnt Rqrd: Fusing Unit"
"Replace Fusing Unit."
- SP C342DN
"Fusing Unit must be replaced now. Replace Fusing Unit."

When the following message appears on the display, the fusing unit should be replaced soon.

- SP C340DN
"Repl Requrd Soon: FusingUnit"
- SP C342DN
"Replacement of Fusing Unit will soon be necessary. A new unit is required. Please contact your local vendor."

Consumables

This section describes the information on consumables for SP C340DN. For SP C342DN, contact your service representative.

When replacing consumables, refer to the maintenance guide provided with the new items for the replacement, and read the precautions about how to replace consumables before replacing. For details about the precautions, see page 449 "Replenishing and Replacing Consumables".

Print Cartridge

Toner
Black (Low yield)
Cyan, Magenta, Yellow (Low yield)
Black
Cyan, Magenta, Yellow

7

↓ Note

- Our products are engineered to meet the highest standards of quality and functionality. When you purchase consumables, we recommend using only those specified by an authorized dealer.
- If the toner is not changed when necessary, printing will become impossible. We recommend keeping a stock of toner or purchasing one soon.
- The actual number of printable pages varies depending on the image volume and density, number of pages to be printed at a time, paper type and paper size used, contents of print images, and environmental conditions such as temperature and humidity.
- Toner (consumable) is not covered by warranty. However, if there is a problem, contact the store where you purchased it.
- Toner may need to be changed sooner than indicated above due to deterioration over the period of use.

Waste Toner Bottle

Name	Average number of printable pages *1
Waste Toner Bottle SP C310	55,000 pages

*1 A4/letter 5% test chart, 3 pages / job, printing in 50% monochrome/color.

↓ Note

- The number of printable pages is an estimate, based on continuous print jobs of three pages. The actual number of printable pages varies depending on the image volume and density, number of pages to be printed at a time, paper type and paper size used, contents of print images, and environmental conditions such as temperature and humidity.
- If the waste toner bottle is not changed when necessary, printing will become impossible. We recommend keeping a stock of waste toner bottle or purchasing one soon.
- Waste toner bottles are consumables and not covered by warranty. However, if there is a problem, contact the store where you purchased them.

Intermediate Transfer Unit

Name	Average number of printable pages
Transfer Unit SP C310	90,000 pages

↓ Note

- The number of printable pages is an estimate, based on continuous print jobs of three pages. The actual number of printable pages varies depending on the image volume and density, number of pages to be printed at a time, paper type and paper size used, contents of print images, and environmental conditions such as temperature and humidity.
- If the intermediate transfer unit is not changed when necessary, the quality of printing is not guaranteed. We recommend keeping a stock of transfer unit or purchasing one soon.
- A transfer unit package contains a transfer roller.

Maintenance Kit

Name	Average printable number of pages
Maintenance Kit SP C320 (includes a fusing unit and transcription roller)	90,000

↓ Note

- The actual number of printable pages varies depending on the image volume and density, number of pages to be printed at a time, paper type and paper size used, and environmental conditions such as temperature and humidity.

- The maintenance kit are not covered by warranty. However, if there is problem, contact the store where they were purchased.

Specifications

This section describes the specifications for the main unit and options.

↓ Note

- We have obtained each author's permission for the use of applications including open-source software applications. For details about the copyright information for these software applications, see "OSS.pdf" on the CD-ROM supplied with the printer.

Specifications for the Printer

Configuration:

Desktop

Print process:

Laser beam scanning & Electrophotographic printing
4 drums tandem method

First print speed:

Full color: 13.5 seconds
B&W: 13.5 seconds

Print speed:

- One-side printing: 25 pages per minute (A4 \square)
- Two-side printing: 26 pages per minute (A4 \square)

Resolution:

600 × 600 dpi Speed (1 bit)
600 × 600 dpi Standard (2 bits)
1200 × 1200 dpi (1 bit)

Paper size:

For details, see page 106 "Paper Size Specifications".

Paper weight:

For details, see page 108 "Paper Type Specifications".

Paper output capacity:

Standard 150 sheets (80 g/m², 20 lb. BOND)

Paper input capacity:

Tray	Paper capacity ^{*1}
Standard paper feed tray	500 sheets
Bypass tray	100 sheets
500-sheet paper feed unit	500 sheets

^{*1} Paper weight: 80 g/m² (20 lb. BOND)

Power requirements:

- 
 **Region A** (mainly Europe and Asia)

 220–240 V, 50/60 Hz, 6 A

- 
 **Region B** (mainly North America)

 120 V, 60 Hz, 11 A

 220-240 V, 50/60 Hz, 6 A

Power consumption (complete system):

Maximum: 1,300 W

The complete system consists of the main unit and the three optional paper feed units.

The power level when the main switch is turned off and the power cord is plugged into an outlet: 1 W or less

Power consumption (main unit only):

Ready: 60 W

During printing: 650 W

The power level when the main switch is turned off and the power cord is plugged into an outlet: 1 W or less

Warm-up time (23 °C (73.4 °F), rated voltage):**■ SP C340DN**

20 seconds

■ SP C342DN

23 seconds

Dimensions:**Printer only (tray not extended)**

	Width	Depth	Height
SP C340dn	400 mm (15.8 inches)	480 mm (18.9 inches)	387 mm (15.3 inches)
SP C342DN	400 mm (15.8 inches)	480 mm (18.9 inches)	404–467 mm (15.9–18.4 inches)

Note

- SP C340DN:
 - There are protrusions of 12 mm (0.5 inches) on the control panel and 20 mm (0.8 inches) on the handles of the standard paper tray.
 - When Tray 1 is extended, the depth increases by 125 mm (4.9 inches).
- SP C342DN:
 - There are protrusions of 16 mm (0.7 inches) on the control panel and 20 mm (0.8 inches) on the handles of the standard paper tray.
 - When the control panel is tilted, the height increases by up to 63 mm (2.5 inches).
 - When Tray 1 is extended, the depth increases by 125 mm (4.9 inches).

Weight:**SP C340DN**

Approx. 29 kg (63.9 lb.)

SP C342DN

Approx. 30 kg (66.1 lb.)

Noise emission:

- Sound power level:
 - Main unit only

Stand-by	40.0 dB (A)
Printing	Full color: 65.5 dB (A) B&W: 64.8 dB (A)

- Complete system

Stand-by	40.0 dB (A)
Printing	69.5 dB (A)

- Sound pressure level:

- Main unit only

Stand-by	28.0 dB (A)
Printing	Full color: 50.0 dB (A) B&W: 57.2 dB (A)

- Complete system

Stand-by	28.0 dB (A)
Printing	53.0 dB (A)

- Sound power levels and sound pressure levels are actual values measured in accordance with ISO 7779.
- Sound pressure levels are measured from the position of the bystander.
- The complete system consists of the main unit and the three optional paper feed units.

Memory:

Standard 512 MB, up to 2 GB (with the standard SDRAM module)

Hard disk:

320 GB (Optional)

Interfaces:

Standard:

- Gigabit Ethernet (10BASE-T/100BASE-TX/1000BASE-T)
- USB 2.0

To use USB 2.0, a USB computer port and cable that support USB 2.0 are required.

- USB Host
- SD card slot

Optional:

- IEEE 802.11 a/b/g/n (Wireless LAN)
- Parallel (Bidirectional IEEE 1284)
- USB device server (10BASE-T/100BASE-TX/1000BASE-T)

Printer Language:

PCL5c/6, PostScript 3, PDF, PictBridge (optional), XPD (optional)

Fonts:

PCL 5c/PCL 6:

45 fonts, 13 International fonts

PostScript 3, PDF:

136 fonts

Network:

Topology: The physical or logical layout of the nodes (devices) in a network (10BASE-T/100BASE-TX/1000BASE-T)

Protocol: TCP/IP (IPv4, IPv6), IPX/SPX

Note

- First print speed, power consumption, warm-up time, sound power level and sound pressure level may differ depending on the conditions and environment of the printer.

Specifications for 500-sheet Paper Feed Unit

Paper size:

For details, see page 106 "Paper Size Specifications".

Paper weight:

For details, see page 108 "Paper Type Specifications".

Paper capacity (80 g/m², 20 lb. Bond):

500 sheets × 1 tray

Power consumption:

12.2 W or less (Power is supplied from the main unit.)

Dimensions (W × D × H):

400 × 480 × 127 mm (15.8 × 18.9 × 5.0 inches)

Weight:

Approx. 6.1 kg (13.5 lb.)

Note

- For details about the paper supported by this option, see page 106 "Paper Size Specifications" and page 108 "Paper Type Specifications".

Specification for Hard Disk

Storage Capacity (Formatted):

320 GB

Specifications:

- Spooling print data to collate
- Spooling Sample Print/Locked Print/Hold Print/Stored Print data
- Storing log data

Note

- Storage capacity is subject to change without prior notice.

Specifications for Wireless LAN Interface Board

Important

- Note that the available channels (frequency ranges) and locations to use the wireless LAN are subject to the regulations of the country or region where the printer is used. Be sure to use the wireless LAN according to the applicable regulations.

Transmission spec.:

Based on IEEE 802.11a/b/g/n (Wireless LAN)

Protocol:

TCP/IP, IPX/SPX

Transmission Rate:

1–300 Mbps

Frequency range (Center Frequency):

- 2412–2472 MHz (1–13 channels)
- 5180–5320 MHz (36, 40, 44, 48, 52, 56, 60, and 64 channels)
- 5500–5700 MHz (100, 104, 108, 112, 116, 120, 124, 128, 132, 136, and 140 channels)

Ad-hoc mode Channel Frequency range (Center Frequency):

- 2412–2462 MHz (1–11 channels)

- 5180–5240 MHz (36, 40, 44, and 48 channels)

Transmission mode:

- Ad hoc mode
- Infrastructure mode

Note

- Web Image Monitor is supported.
- A transmission rate of 300 Mbps is a theoretical value of the wireless LAN specification.
- The maximum transmission rate in the ad-hoc mode is 54 Mbps for IEEE802.11a and 11 Mbps for IEEE802.11b/g. The Ad-hoc communication is not supported in an IEEE802.11n environment.
- The channel in use might differ depending on the country.

Specifications for IEEE1284 Interface Board

★ Important

- Do not use an IEEE 1284 cable that is longer than 3 meters.

Transmission spec.:

IEEE 1284

Required cable:

Standard IEEE 1284 compliant Micro Centronics 36 pin cable

7

Specifications for USB Device Server

Interfaces:

- Gigabit Ethernet (10BASE-T/100BASE-TX/1000BASE-T)
- USB 2.0 (For connecting the printer and the print server interface)

Operating Systems:

- Windows Vista/7/8/8.1/10, Windows Server 2003/2008/2008 R2/2012
- Mac OS X 10.3 to 10.8

Protocols:

- The USB device server supports Port 9100, IPP, and LPR only. IPP does not support SSL.
- The USB device server allows simultaneous connection of up to 8 sessions of printing protocols.

Information for This Printer

User Information on Electrical & Electronic Equipment Region A

Users in the countries where this symbol shown in this section has been specified in national law on collection and treatment of E-waste

Our Products contain high quality components and are designed to facilitate recycling.

Our products or product packaging are marked with the symbol below.



The symbol indicates that the product must not be treated as municipal waste. It must be disposed of separately via the appropriate return and collection systems available. By following these instructions you ensure that this product is treated correctly and help to reduce potential impacts on the environment and human health, which could otherwise result from inappropriate handling. Recycling of products helps to conserve natural resources and protect the environment.

For more detailed information on collection and recycling systems for this product, please contact the shop where you purchased it, your local dealer or sales/service representatives.

All Other Users

If you wish to discard this product, please contact your local authorities, the shop where you bought this product, your local dealer or sales/service representatives.

For Turkey only

EEE Yönetmeliğine Uygundur.

Bu sistem sarf malzemeleri ve yedek parçaları da dahil olmak üzere EEE Yönetmeliğine Uygundur.

For Users in India

This product complies with the "India E-waste Rule 2011" and prohibits use of lead, mercury, hexavalent chromium, polybrominated biphenyls or polybrominated diphenyl ethers in concentrations

exceeding 0.1 weight % and 0.01 weight % for cadmium, except for the exemptions set in Schedule 2 of the Rule.

EMC Directive

Using the Shield Cable

Properly shielded and grounded cables and connectors must be used for connections to a host computer (and/or peripheral) in order to meet emission limits.

Note for the Battery and/or Accumulator Symbol (For EU countries only)



In accordance with the Battery Directive 2006/66/EC Article 20 Information for end-users Annex II, the above symbol is printed on batteries and accumulators.

This symbol means that in the European Union, used batteries and accumulators should be disposed of separately from your household waste.

In the EU, there are separate collection systems for not only used electrical and electronic products but also batteries and accumulators.

Please dispose of them correctly at your local community waste collection/recycling centre.

Environmental Advice for Users

Users in the EU, Switzerland and Norway

Consumables yield

Please refer to either the User's Manual for this information or the packaging of the consumable.

Recycled paper

The machine can use recycled paper which is produced in accordance with European standard EN 12281:2002 or DIN 19309. For products using EP printing technology, the machine can print on 64 g/m² paper, which contains less raw materials and represents a significant resource reduction.

Duplex printing (if applicable)

Duplex printing enables both sides of a sheet of paper to be used. This saves paper and reduces the size of printed documents so that fewer sheets are used. We recommend that this feature is enabled whenever you print.

Toner and ink cartridge return program

Toner and ink cartridge for recycling will be accepted free of charge from users in accordance with local regulations.

For details about the return program, please refer to the Web page below or consult your service person.

<https://www.ricoh-return.com/>

Energy efficiency

The amount of electricity a machine consumes depends as much on its specifications as it does on the way you use it. The machine is designed to allow you to reduce electricity costs by switching to Ready mode after it prints the last page. If required, it can immediately print again from this mode. If no additional prints are required and a specified period of time passes, the device switches to an energy saving mode.

In these modes, the machine consumes less power (watts). If the machine is to print again, it needs a little longer to return from an energy saving mode than from Ready mode.

For maximum energy savings, we recommend that the default setting for power management is used.

Products that comply with the Energy Star requirement are always energy efficient.

7

Notes for users in the state of California Region B

Perchlorate Material - special handling may apply. See: www.dtsc.ca.gov/hazardouswaste/perchlorate

ENERGY STAR Program

ENERGY STAR® Program Requirements for Imaging Equipment



The ENERGY STAR® Program Requirements for Imaging Equipment encourage energy conservation by promoting energy efficient computers and other office equipment.

The program backs the development and dissemination of products that feature energy saving functions.

It is an open program in which manufacturers participate voluntarily.

Targeted products are computers, monitors, printers, facsimiles, copiers, scanners, and multifunction devices. Energy Star standards and logos are internationally uniform.



Sleep mode

If this machine remains idle for a specified period, it enters Sleep mode to reduce its electrical consumption.

The default delay time the machine waits before entering Sleep mode is 1 minute. This default time can be changed.

The machine can print jobs from computers while in Sleep mode.

Specification

Reduced electrical consumption in Sleep mode	Less than 1.0 W
Time of switch into Sleep mode	1 minute
Time of switch out from Sleep mode	<p> Region A (mainly Europe and Asia)</p> <p>7.2 seconds</p> <p> Region B (mainly North America)</p> <p>7.9 seconds</p> <p>7.2 seconds</p>

Environmental protection expiration date for use

 <p>China only Environmental protection expiration date</p>	<p>This mark indicates environmental protection expiration date for use that is applied to electronic information product sold in China.</p> <p>As long as you follow the safety instructions and precautions for use of this product, it will not cause environmental pollution nor cause serious harm to the human body or properties, within this term reckoned from the manufacturing date. This term is derived based on the safety use expiration law.</p>
--	--

Fixed form sentences 11 _ china environmental labeling notice _ LP_Title Sentence 1

- Fixed form sentences 11 _ china environmental labeling notice _ LP_BodyText Sentence 1
- Fixed form sentences 11 _ china environmental labeling notice _ LP_BodyText Sentence 3 version 2
- Fixed form sentences 11 _ china environmental labeling notice _ LP_BodyText Sentence 4 version 2
- Fixed form sentences 11 _ china environmental labeling notice _ LP_BodyText Sentence 5
- Fixed form sentences 11 _ china environmental labeling notice _ LP_BodyText Sentence 6
- Fixed form sentences 11 _ china environmental labeling notice _ LP_BodyText Sentence 7

Fixed form sentences 11 _ china environmental labeling notice _ LP_Annotation Sentence 1

Fixed form sentences 11 _ china environmental labeling notice _ LP_Annotation Sentence 2

Appendix

Trademarks

Adobe, Acrobat, PostScript, PostScript 3, and Reader are either registered trademarks or trademarks of Adobe Systems Incorporated in the United States and/or other countries.

Bonjour, Macintosh, Mac OS, OS X, and Safari are trademarks of Apple Inc., registered in the United States and other countries.

Citrix, Citrix Presentation Server and Citrix XenApp are either registered trademarks or trademarks of Citrix Systems, Inc.

Firefox[®] is a registered trademark of the Mozilla Foundation.

IPS is a trademark or registered trademark of Zoran Corporation and/or its subsidiaries in the United States or other countries.

Java is a registered trademark of Oracle and/or its affiliates.

JAWS[®] is a registered trademark of Freedom Scientific, Inc., St. Petersburg, Florida and/or other countries.

Microsoft, Windows, Windows Server, Windows Vista, and Internet Explorer are either registered trademarks or trademarks of Microsoft Corporation in the United States and/or other countries.

Monotype is a registered trademark of Monotype Imaging Inc.

IPX, IPX/SPX, NCP, and NDS are either registered trademarks or trademarks of Novell, Inc.

OpenLDAP is a registered trademark of the OpenLDAP Foundation.

PCL[®] is a registered trademark of Hewlett-Packard Company.

PictBridge is a trademark.

UNIX is a registered trademark of the Open Group.

UPnP[™] is a trademark of the UPnP[™] Implementers Corporation.

The proper name of Internet Explorer 6 is Microsoft[®] Internet Explorer[®] 6.

The proper name of Internet Explorer 8 is Windows[®] Internet Explorer[®] 8.

The proper names of the Windows operating systems are as follows:

- The product names of Windows Vista are as follows:

Microsoft[®] Windows Vista[®] Ultimate

Microsoft[®] Windows Vista[®] Business

Microsoft[®] Windows Vista[®] Home Premium

Microsoft[®] Windows Vista[®] Home Basic

Microsoft[®] Windows Vista[®] Enterprise

- The product names of Windows 7 are as follows:
 - Microsoft® Windows® 7 Home Premium
 - Microsoft® Windows® 7 Professional
 - Microsoft® Windows® 7 Ultimate
 - Microsoft® Windows® 7 Enterprise
- The product names of Windows 8 are as follows:
 - Microsoft® Windows® 8
 - Microsoft® Windows® 8 Pro
 - Microsoft® Windows® 8 Enterprise
- The product names of Windows 8.1 are as follows:
 - Microsoft® Windows® 8.1
 - Microsoft® Windows® 8.1 Pro
 - Microsoft® Windows® 8.1 Enterprise
- The product names of Windows 10 are as follows:
 - Microsoft® Windows® 10 Home
 - Microsoft® Windows® 10 Pro
 - Microsoft® Windows® 10 Enterprise
 - Microsoft® Windows® 10 Education
- The product names of Windows Server 2003 are as follows:
 - Microsoft® Windows Server® 2003 Standard Edition
 - Microsoft® Windows Server® 2003 Enterprise Edition
- The product names of Windows Server 2003 R2 are as follows:
 - Microsoft® Windows Server® 2003 R2 Standard Edition
 - Microsoft® Windows Server® 2003 R2 Enterprise Edition
- The product names of Windows Server 2008 are as follows:
 - Microsoft® Windows Server® 2008 Standard
 - Microsoft® Windows Server® 2008 Enterprise
- The product names of Windows Server 2008 R2 are as follows:
 - Microsoft® Windows Server® 2008 R2 Standard
 - Microsoft® Windows Server® 2008 R2 Enterprise
- The product names of Windows Server 2012 are as follows:
 - Microsoft® Windows Server® 2012 Foundation
 - Microsoft® Windows Server® 2012 Essentials

Microsoft® Windows Server® 2012 Standard

- The product names of Windows Server 2012 R2 are as follows:

Microsoft® Windows Server® 2012 R2 Foundation

Microsoft® Windows Server® 2012 R2 Essentials

Microsoft® Windows Server® 2012 R2 Standard

Other product names used herein are for identification purposes only and might be trademarks of their respective companies. We disclaim any and all rights to those marks.

Microsoft product screen shots reprinted with permission from Microsoft Corporation.

MEMO