

EMC TEST REPORT

Report No.: SET2015-17821

Product: Multifunction Digital Product (Copier/Printer/Scanner)

Model No. : SP 150SUw

FCC ID: BBP-MFSP150SUW1

Applicant: Ricoh Company Ltd

Issued by: CCIC Southern Electronic Product Testing (Shenzhen) Co., Ltd.

Lab Location: Electronic Testing Building, No. 43 Shahe Road, Xili Jiedao,
Nanshan District, 518055 Shenzhen, Guangdong, China

Tel: 86 755 26627338 **Fax:** 86 755 26627238

This test report consists of **62** pages in total. It may be duplicated completely for legal use with the approval of the applicant. It should not be reproduced except in full, without the written approval of our laboratory. The client should not use it to claim product endorsement by CCIC-SET. The test results in the report only apply to the tested sample. The test report shall be invalid without all the signatures of testing engineers, reviewer and approver. Any objections must be raised to CCIC-SET within 15 days since the date when the report is received. It will not be taken into consideration beyond this limit.

Test Report

Product Multifunction Digital Product (Copier/Printer/Scanner)

Model No. SP 150SUw

Applicant Ricoh Company Ltd

Applicant Address 810 Shimoimaizumi, Ebina City, Kanagawa-Pref., 243-0460 Japan

Manufacturer RICOH Co., LTD.

Manufacturer Address 3-6, Naka-magome 1-Chome Ohta-ku, Tokyo 143-8555 Japan

Test Standards..... FCC PART 15 Subpart B
ANSI C63.4: 2009

Test Result PASS

Tested by Xu Weiwei Nov. 27. 2015
Signature, Date

Reviewed by Zhu Qi Nov. 27. 2015
Signature, Date

Approved by..... Wu Lian Nov. 27. 2015
Signature, Date

Table of Contents

1 General Information	4
1.1 Description of EUT	4
1.2 EUT Information	4
1.3 Highest Frequency Generated or Used in The Device or on Which the Device Operates	4
2 Test Facilities and Configuration	5
2.1 Environmental Conditions	5
2.2 Measurement Uncertainty	5
2.3 Associated Equipments	5
2.4 Cables Used	5
2.5 Test Configure	6
2.6 Measurement Equipments Used	7
3 Summary of Test Results	8
4 Emission Test	9
4.1 EUT Setup and Operation	9
4.2 Conducted Disturbance at Mains Terminals	10
4.2.1 Limits of Conducted Disturbance at Mains Terminals	10
4.2.2 Test Procedure	10
4.2.3 Test Setup	10
4.2.4 Test Result	11
4.3 Radiated Emission Test	24
4.3.1 Limits of Radiated Emission	24
4.3.2 Test Procedure	24
4.3.3 Test Setup	25
4.3.4 Test Results	25
Appendix I: Photographs of the EUT	50
Appendix II: Photographs of EMC Test Configuration	61

1 General Information

1.1 Description of EUT

Product: Multifunction Digital Product(Copier/Printer/Scanner)

Model No.: SP 150SUw

Brand Name: Ricoh

Serial No.: L0011750012

I/O Ports: USB

Accessories: Power cable ,USB cable

Note:

The EUT is class B information technology equipment according to FCC PART 15. For more detailed features description about the EUT, please refer to User’s Manual.

Perform ElectroMagnetic Interference measurement in accordance with FCC 47CFR [Codes of Federal Regulations] Part 15 and ANSI C63.4: 2009 for FCC ID

The EUT have WIFI module, which have finished the FCCID (FCCID code : PPQ-WN4615L) .

Short description of the equipment under test (EUT)

The certification machine is a Multifunction Digital Product which has copy, scan and print function.#

1.2 EUT Information

Kind of equipment	Manufacturer	Model name	Serial number	Remark
Multifunction Digital Product	Ricoh	SP 150SUw	L0011750012	-

1.3 Highest Frequency Generated or Used in The Device or on Which the Device Operates

Kind of equipment	Model name	Operates Frequency	Remark
Multifunction Digital Product	SP 150SUw	480MHz	USB

2 Test Facilities and Configuration

2.1 Environmental Conditions

During the measurement the environmental conditions were within the listed ranges:

- Temperature: 15-35°C
- Humidity: 30-60 %
- Atmospheric pressure: 86-106 kPa

2.2 Measurement Uncertainty

The uncertainty is calculated using the methods suggested in the “Guide to the Expression of Uncertainty in Measurement” (GUM) published by ISO.

- Uncertainty of Conducted Emission, $U_c = \pm 1.8\text{dB}$
- Uncertainty of Radiated Emission, $U_c = \pm 5.0\text{dB}$

2.3 Associated Equipments

Kind of equipment	Manufacturer	Model name	Serial number	Remarks
Notebook	LENOVO	ThinkPad L440	R9-0346Y3 14/07	DoC
Wireless Router	Buffalo	WCR-HP-GN	44061000300952	
Keyboard	DELL	L100	CNORH6566589079K0277	DoC
Mouse	DELL	MOC5UO	H0F02OCQ	DoC

2.4 Cables Used

Item	Cable Name	Length	Shielding	Maker
1	USB Cable	2.0m	YES	New Nam Lee
2	Power Cable	1.5m	No	Longwell

2.5 Test Configure

Operating modes:

No.	Operating modes	Remarks
1	Standby	
2	Copy	
3	USB Print	
4	WiFi Print	
5	USB Scan	
6	WiFi Scan	

EUT Setup

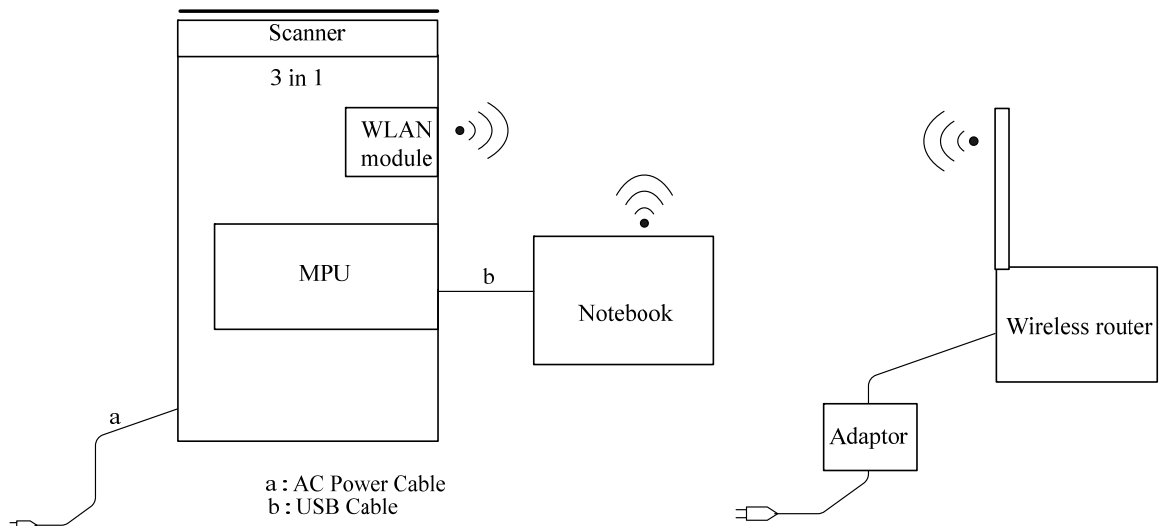

2.6 Measurement Equipments Used

Description	Manufacturer	Model No.	Serial No.	Cal. Date	Cal. Due Date
Test Receiver	ROHDE&SCHWARZ	ESCS30	A0304260	Jun.10, 2015	Jun.10, 2016
LISN	Schwarzbeck	ESH2-Z5	A0304221	Jun.10, 2015	Jun.10, 2016
Shield Room	Nanbo Tech	Site 3	A9901141	Jun.10, 2015	Jun.10, 2016
Horn Ant.	ROHDE&SCHWARZ	HF906	A0304225	Jun.10, 2015	Jun.10, 2016
Anechoic Chamber	Albatross	SAC-10M AC19.6*11 .8*8.55m	A0802520	Sep.17, 2015	Sep.17, 2016
Test Receiver	ROHDE&SCHWARZ	ESU8	A0805559	Jun.10, 2015	Jun.10, 2016
Ultra-Broadband Ant.	Schwarzbeck	VULB 09160	A0805560	Jun.10, 2015	Jun.10, 2016

NOTE: Equipments above have been calibrated and are in the period of validation.

3 Summary of Test Results

The EUT has been tested according to the following specifications:

EMISSION			
Test Condition	Test Requirement	Test Method	Result
Radiated Emissions	FCC 47CFR Part15 Subpart B	ANSI C63.4:2009	PASS
Conducted Emissions on AC, 0.15MHz to 30MHz	FCC 47CFR Part15 Subpart B	ANSI C63.4:2009	PASS

4 Emission Test

4.1 EUT Setup and Operation

The EUT was powered by 120V AC Mains.

The EUT continuously operated during the test modes as section 2.5.

The EUT and cables, and operation modes were configured to produce the maximum level of emissions.

4.2 Conducted Disturbance at Mains Terminals

4.2.1 Limits of Conducted Disturbance at Mains Terminals

Frequency range (MHz)	Limits (dB μ V), Class B ITE	
	Quasi-peak	Average
0.15-0.5	66 to 56*	56 to 46*
0.5-5.0	56	46
5.0-30.0	60	50

NOTE:

1. The lower limit shall apply at the transition frequencies.
2. The limit decreases linearly with the logarithm of the frequency in the range 0.15MHz to 0.50MHz.

4.2.2 Test Procedure

- a. The EUT was placed 0.4 meters from the conducting wall of shielded room with EUT being connected to the power mains through a line impedance stabilization network (LISN). The LISN provide 50 Ω /50 μ H of coupling impedance for the measuring instrument.
- b. Both lines of the power mains connected to the EUT were checked for maximum conducted interference.
- c. The frequency range from 150 kHz to 30 MHz was searched. Emission levels over 10dB under the prescribed limits are not reported.

4.2.3 Test Setup

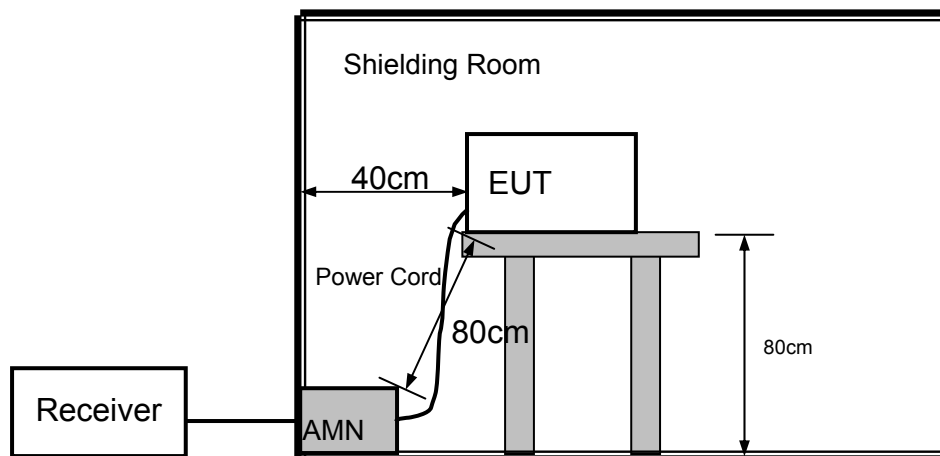

For the actual test configuration, please refer to the related item - Photographs of the Test Configuration.

4.2.4 Test Result

Environment Condition:

Temperature: 23°C; Relative Humidity: 52%; Pressure:101kPa

Test Date: 2015-10-20

Test Engineer: Cheng Weichang

Test Site: Shield Room Site 1

Test Mode: Mode 1-6

1. Conducted Disturbance at Mains Terminals (Standby Mode)

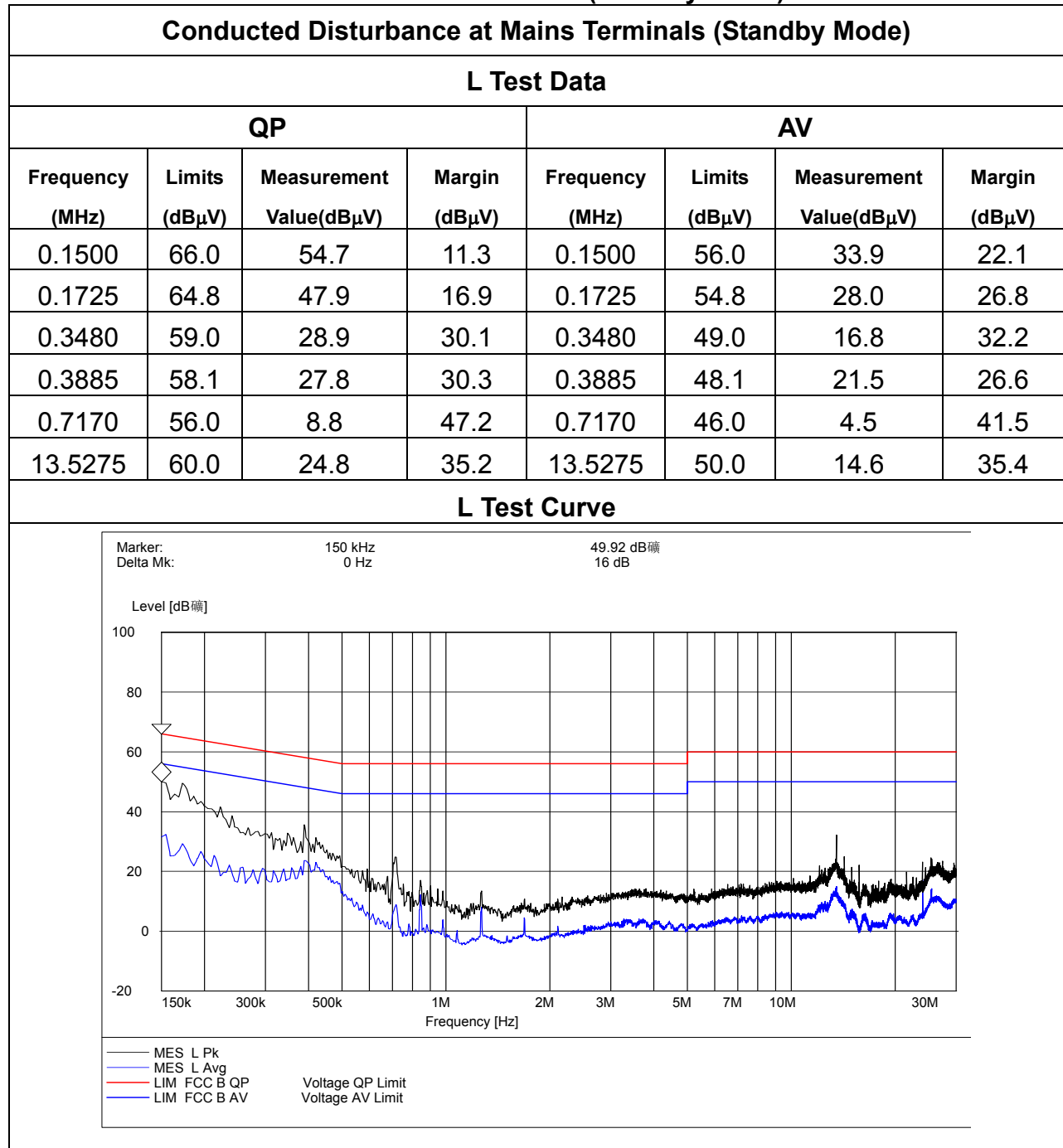

NOTE:

1. The lower limit shall apply at the transition frequencies.
2. The limit decreases linearly with the logarithm of the frequency in the range 0.15MHz to 0.50MHz.
3. The minimum margin value of quasi-peak and average level is over 3dB.

Conducted Disturbance at Mains Terminals (Standby Mode)

N Test Data

QP				AV			
Frequency (MHz)	Limits (dBμV)	Measurement Value(dBμV)	Margin (dBμV)	Frequency (MHz)	Limits (dBμV)	Measurement Value(dBμV)	Margin (dBμV)
0.1500	66.0	55.2	10.8	0.1500	56.0	34.4	21.6
0.1680	65.1	44.2	20.9	0.1680	55.1	28.9	26.2
0.4200	57.4	28.1	29.3	0.4200	47.4	23.1	24.3
0.8475	56.0	16.6	39.4	0.8475	46.0	13.4	32.6
1.2705	56.0	7.5	48.5	1.2705	46.0	4.8	41.2
13.5320	60.0	24.1	35.9	13.5320	50.0	14.8	35.2

N Test Curve

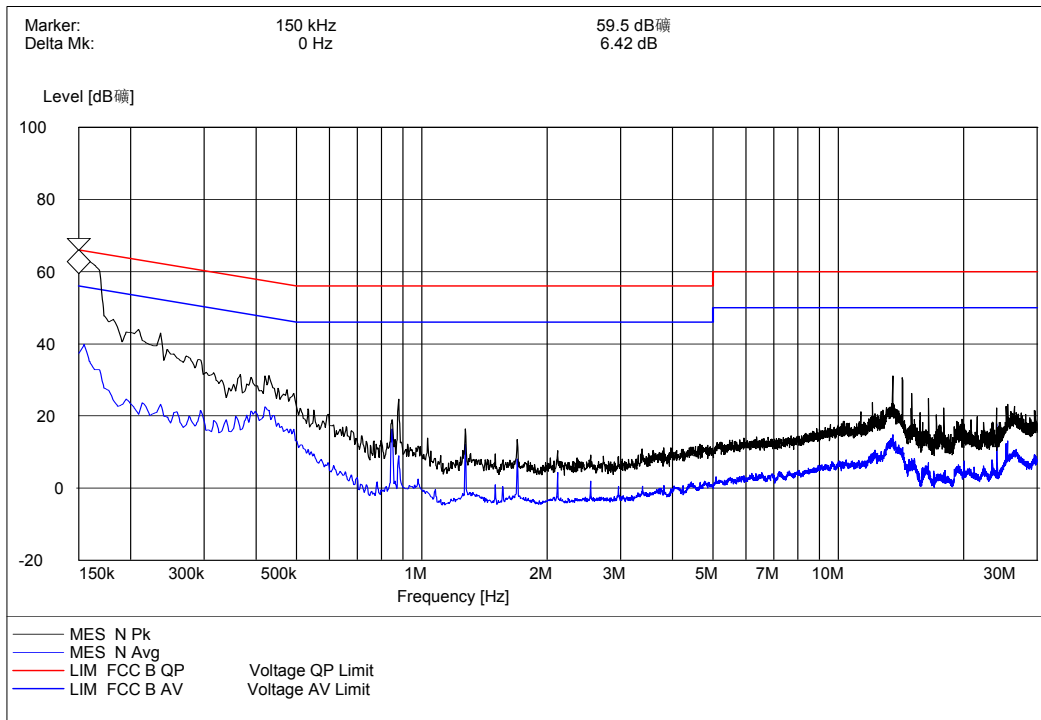

NOTE:

1. The lower limit shall apply at the transition frequencies.
2. The limit decreases linearly with the logarithm of the frequency in the range 0.15MHz to 0.50MHz.
3. The minimum margin value of quasi-peak and average level is over 3dB.

2. Conducted Disturbance at Mains Terminals (Copy Mode)

Conducted Disturbance at Mains Terminals (Copy Mode)							
L Test Data							
QP				AV			
Frequency (MHz)	Limits (dBμV)	Measurement Value(dBμV)	Margin (dBμV)	Frequency (MHz)	Limits (dBμV)	Measurement Value(dBμV)	Margin (dBμV)
0.1500	66.0	57.0	9.0	0.1500	56.0	40.9	15.1
0.2175	62.9	46.8	16.1	0.2175	52.9	34.8	18.1
0.3390	59.2	31.4	27.8	0.3390	49.2	21.9	27.3
0.4290	57.3	27.2	30.1	0.4290	47.3	19.5	27.8
4.6635	56.0	14.7	41.3	4.6635	46.0	9.4	36.6
13.5275	60.0	25.8	34.2	13.5275	50.0	16.4	33.6

L Test Curve

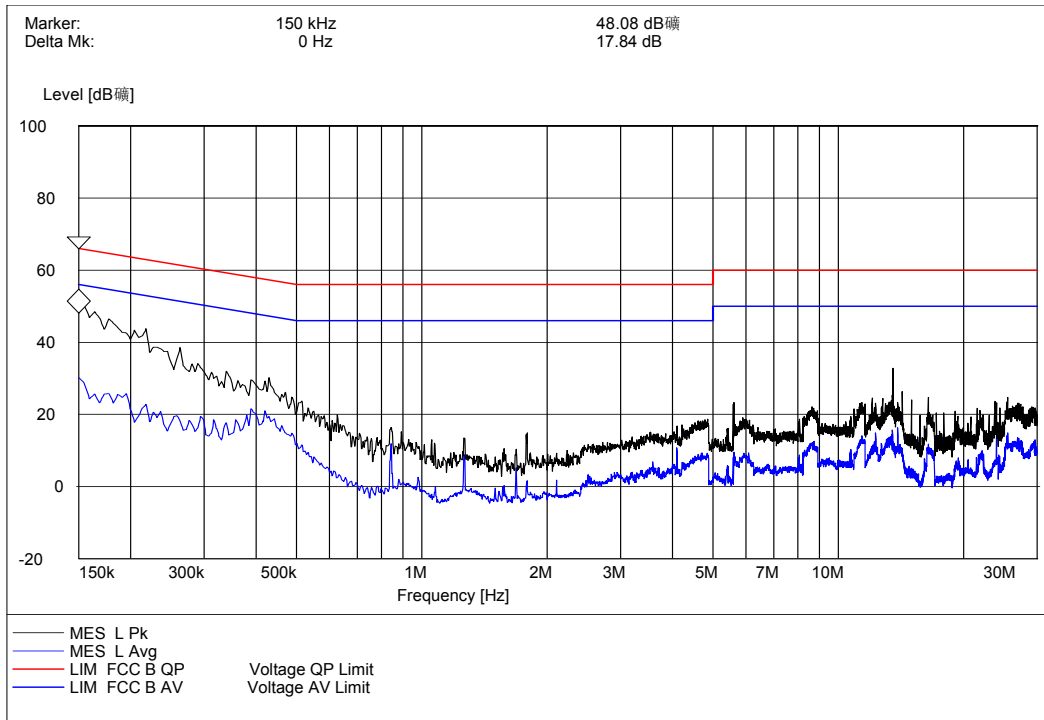

NOTE:

1. The lower limit shall apply at the transition frequencies.
2. The limit decreases linearly with the logarithm of the frequency in the range 0.15MHz to 0.50MHz.
3. The minimum margin value of quasi-peak and average level is over 3dB.

Conducted Disturbance at Mains Terminals (Copy Mode)

N Test Data

QP				AV			
Frequency (MHz)	Limits (dBμV)	Measurement Value(dBμV)	Margin (dBμV)	Frequency (MHz)	Limits (dBμV)	Measurement Value(dBμV)	Margin (dBμV)
0.1500	66.0	55.8	10.2	0.1500	56.0	39.8	16.2
0.2040	63.4	46.4	17.0	0.2040	53.4	30.7	22.7
0.3120	59.9	33.0	26.9	0.3120	49.9	20.7	29.2
0.4200	57.4	27.6	29.8	0.4200	47.4	22.6	24.8
0.8430	56.0	17.9	38.1	0.8430	46.0	15.1	30.9
13.5185	60.0	24.6	35.4	13.5185	50.0	20.4	29.6

N Test Curve

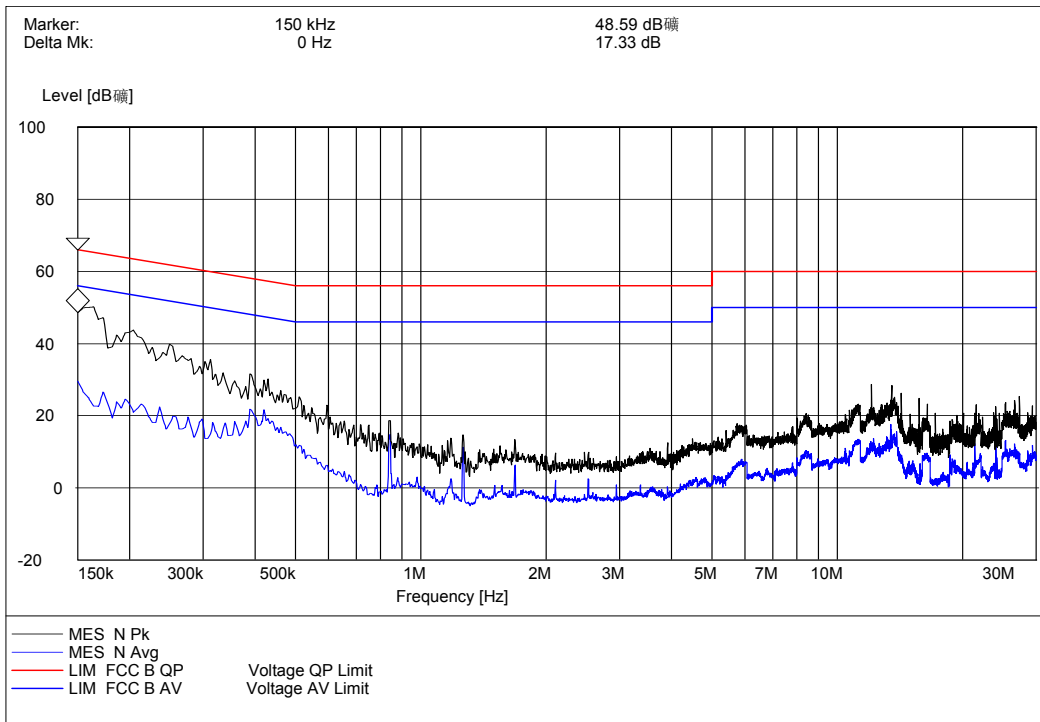

NOTE:

1. The lower limit shall apply at the transition frequencies.
2. The limit decreases linearly with the logarithm of the frequency in the range 0.15MHz to 0.50MHz.
3. The minimum margin value of quasi-peak and average level is over 3dB.

3. Conducted Disturbance at Mains Terminals (USB Print Mode)

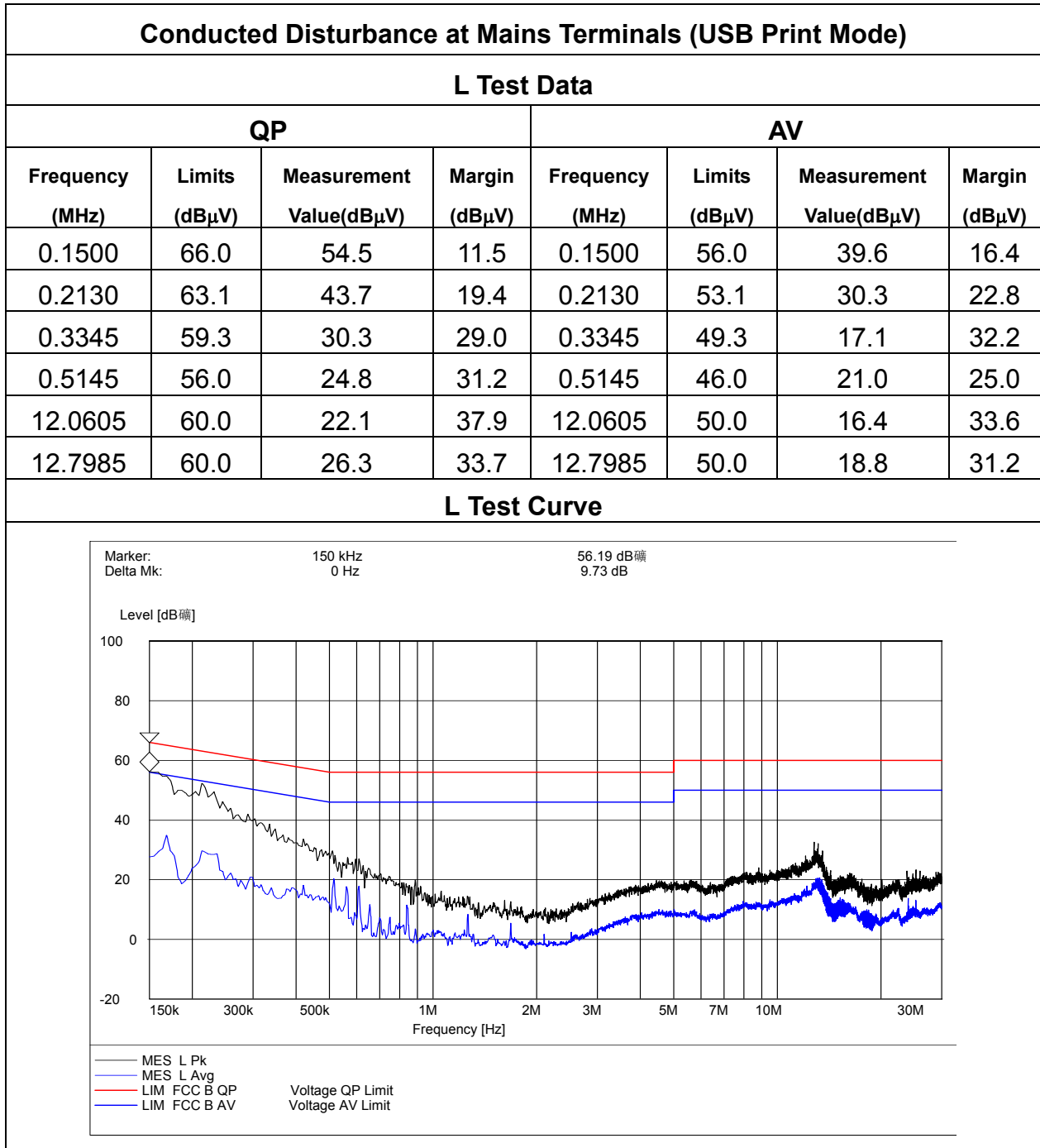

NOTE:

1. The lower limit shall apply at the transition frequencies.
2. The limit decreases linearly with the logarithm of the frequency in the range 0.15MHz to 0.50MHz.
3. The minimum margin value of quasi-peak and average level is over 3dB.

Conducted Disturbance at Mains Terminals (USB Print Mode)

N Test Data

QP				AV			
Frequency (MHz)	Limits (dBµV)	Measurement Value(dBµV)	Margin (dBµV)	Frequency (MHz)	Limits (dBµV)	Measurement Value(dBµV)	Margin (dBµV)
0.1500	66.0	54.4	11.6	0.1500	56.0	39.1	16.9
0.1815	64.4	47.6	16.8	0.1815	54.4	30.2	24.2
0.3165	59.8	31.9	27.9	0.3165	49.8	19.2	30.6
0.5145	56.0	24.5	31.5	0.5145	46.0	21.1	24.9
10.4135	60.0	20.8	39.2	10.4135	50.0	14.9	35.1
12.9605	60.0	25.5	34.5	12.9605	50.0	19.3	30.7

N Test Curve

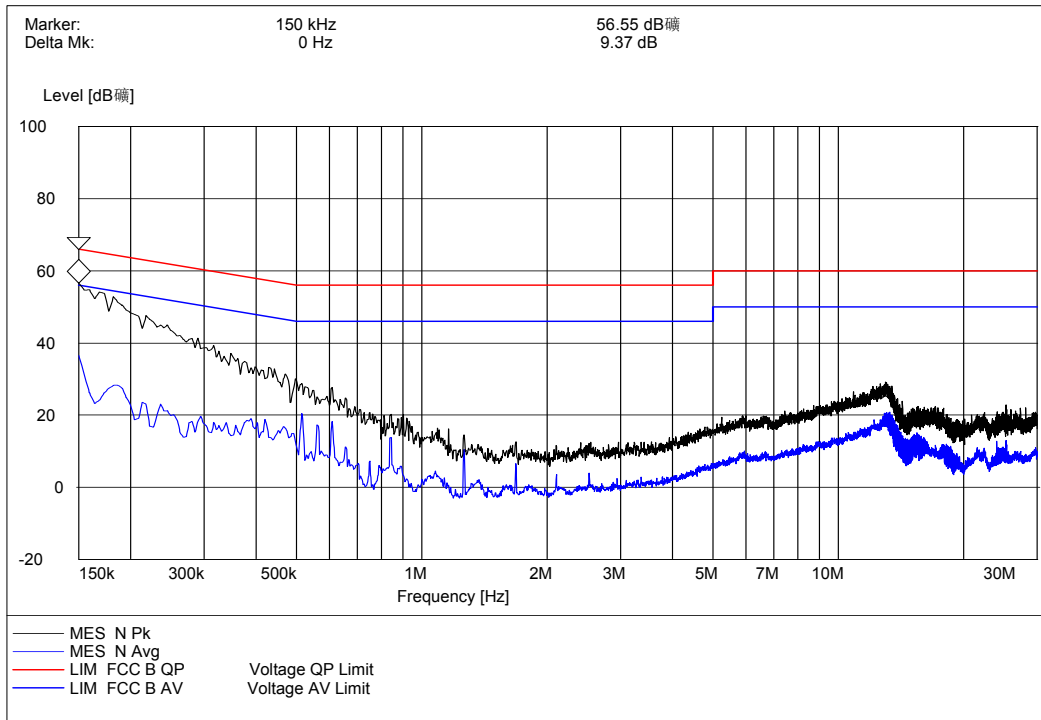

NOTE:

1. The lower limit shall apply at the transition frequencies.
2. The limit decreases linearly with the logarithm of the frequency in the range 0.15MHz to 0.50MHz.
3. The minimum margin value of quasi-peak and average level is over 3dB.

4. Conducted Disturbance at Mains Terminals (WiFi Print Mode)

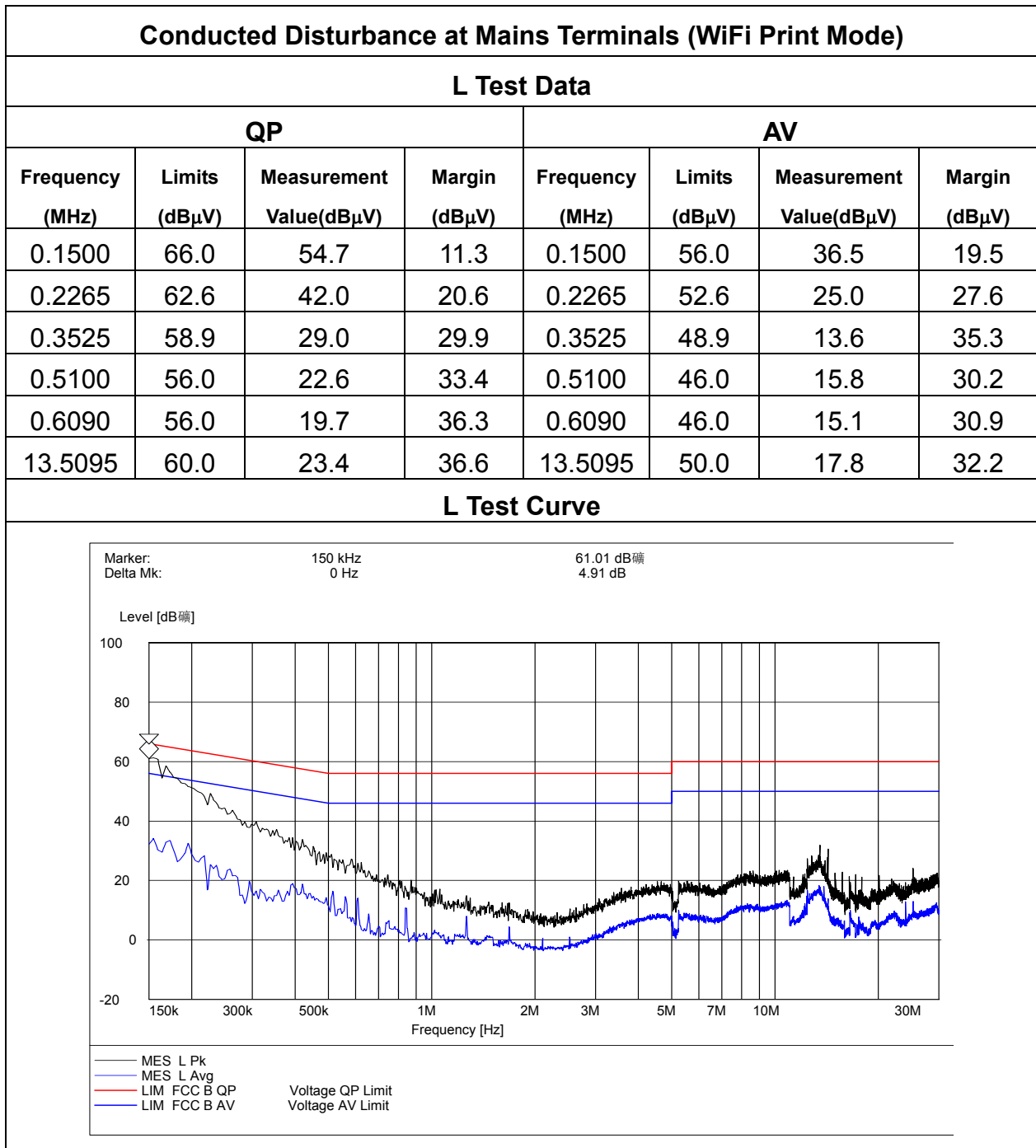

NOTE:

1. The lower limit shall apply at the transition frequencies.
2. The limit decreases linearly with the logarithm of the frequency in the range 0.15MHz to 0.50MHz.
3. The minimum margin value of quasi-peak and average level is over 3dB.

Conducted Disturbance at Mains Terminals (WiFi Print Mode)

N Test Data

QP				AV			
Frequency (MHz)	Limits (dBμV)	Measurement Value(dBμV)	Margin (dBμV)	Frequency (MHz)	Limits (dBμV)	Measurement Value(dBμV)	Margin (dBμV)
0.1500	66.0	54.5	11.5	0.1500	56.0	38.1	17.9
0.1725	64.8	50.5	14.3	0.1725	54.8	39.1	15.7
0.3795	58.3	29.4	28.9	0.3795	48.3	21.0	27.3
0.6045	56.0	19.7	36.3	0.6045	46.0	15.2	30.8
12.7985	60.0	25.2	34.8	12.7985	50.0	16.9	33.1
13.5140	60.0	23.8	36.2	13.5140	50.0	17.6	32.4

N Test Curve

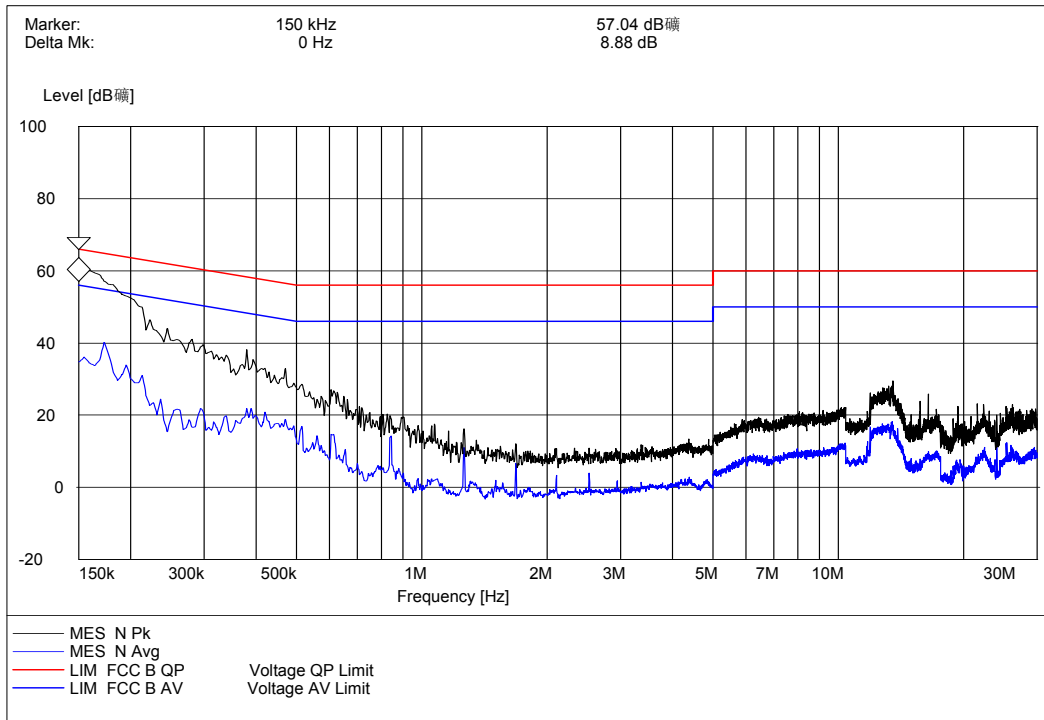

NOTE:

1. The lower limit shall apply at the transition frequencies.
2. The limit decreases linearly with the logarithm of the frequency in the range 0.15MHz to 0.50MHz.
3. The minimum margin value of quasi-peak and average level is over 3dB.

5. Conducted Disturbance at Mains Terminals (USB Scan Mode)

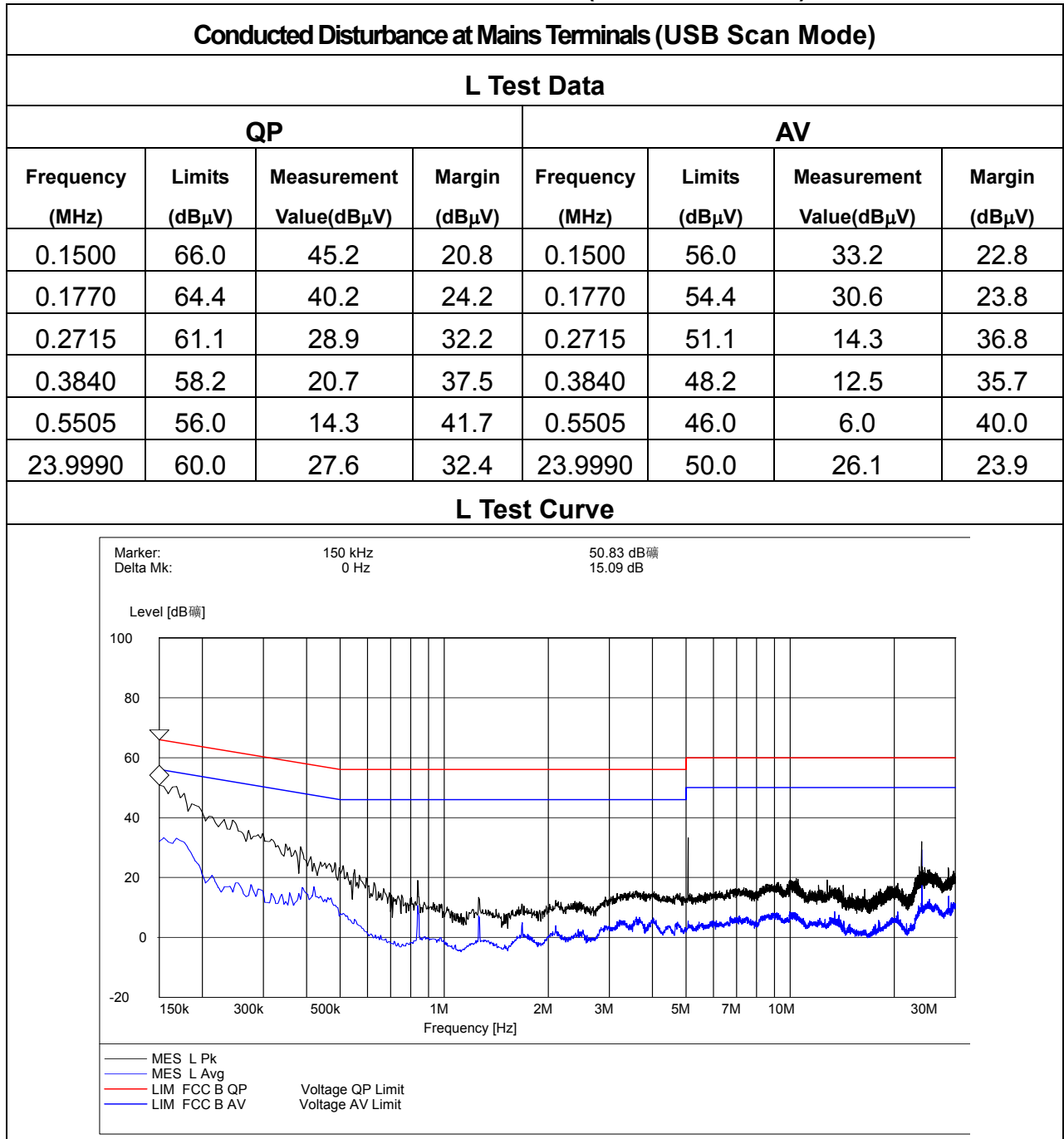

NOTE:

1. The lower limit shall apply at the transition frequencies.
2. The limit decreases linearly with the logarithm of the frequency in the range 0.15MHz to 0.50MHz.
3. The minimum margin value of quasi-peak and average level is over 3dB.

Conducted Disturbance at Mains Terminals (USB Scan Mode)

N Test Data

QP				AV			
Frequency (MHz)	Limits (dBµV)	Measurement Value(dBµV)	Margin (dBµV)	Frequency (MHz)	Limits (dBµV)	Measurement Value(dBµV)	Margin (dBµV)
0.1500	66.0	44.9	21.1	0.1500	56.0	30.2	25.8
0.1815	64.4	39.2	25.2	0.1815	54.4	26.5	27.9
0.2490	61.8	31.7	30.1	0.2490	51.8	17.3	34.5
0.3480	59.0	22.8	36.2	0.3480	49.0	11.6	37.4
0.5550	56.0	14.2	41.8	0.5550	46.0	7.3	38.7
23.9990	60.0	25.7	34.3	23.9990	50.0	23.9	26.1

N Test Curve

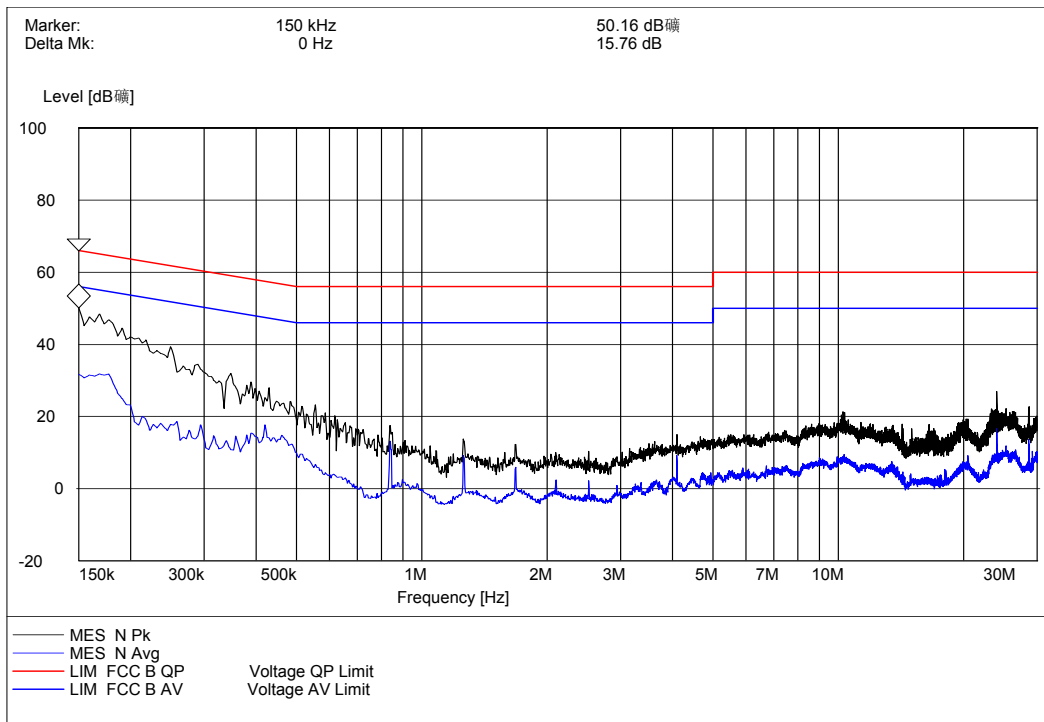

NOTE:

1. The lower limit shall apply at the transition frequencies.
2. The limit decreases linearly with the logarithm of the frequency in the range 0.15MHz to 0.50MHz.
3. The minimum margin value of quasi-peak and average level is over 3dB.

6. Conducted Disturbance at Mains Terminals (WiFi Scan Mode)

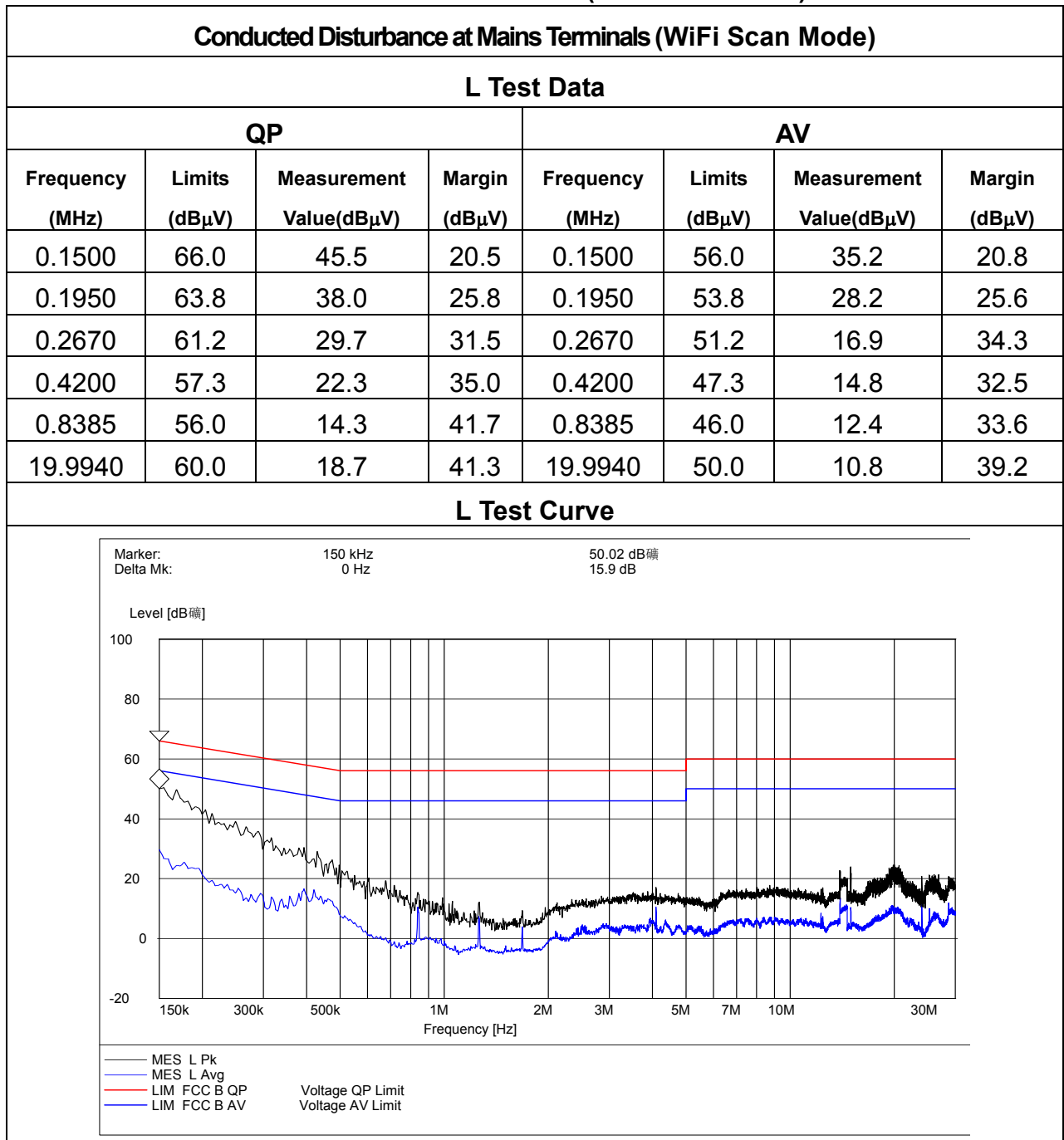

NOTE:

1. The lower limit shall apply at the transition frequencies.
2. The limit decreases linearly with the logarithm of the frequency in the range 0.15MHz to 0.50MHz.
3. The minimum margin value of quasi-peak and average level is over 3dB.

Conducted Disturbance at Mains Terminals (WiFi Scan Mode)

N Test Data

QP				AV			
Frequency (MHz)	Limits (dBµV)	Measurement Value(dBµV)	Margin (dBµV)	Frequency (MHz)	Limits (dBµV)	Measurement Value(dBµV)	Margin (dBµV)
0.1500	66.0	44.9	21.1	0.1500	56.0	26.5	29.5
0.1905	64.0	38.1	25.9	0.1905	54.0	22.4	31.6
0.3210	59.7	24.7	35.0	0.3210	49.7	12.4	37.3
0.4290	57.3	22.1	35.2	0.4290	47.3	14.8	32.5
0.8430	56.0	15.0	41.0	0.8430	46.0	12.8	33.2
24.5885	60.0	12.4	47.6	24.5885	50.0	6.8	43.2

N Test Curve

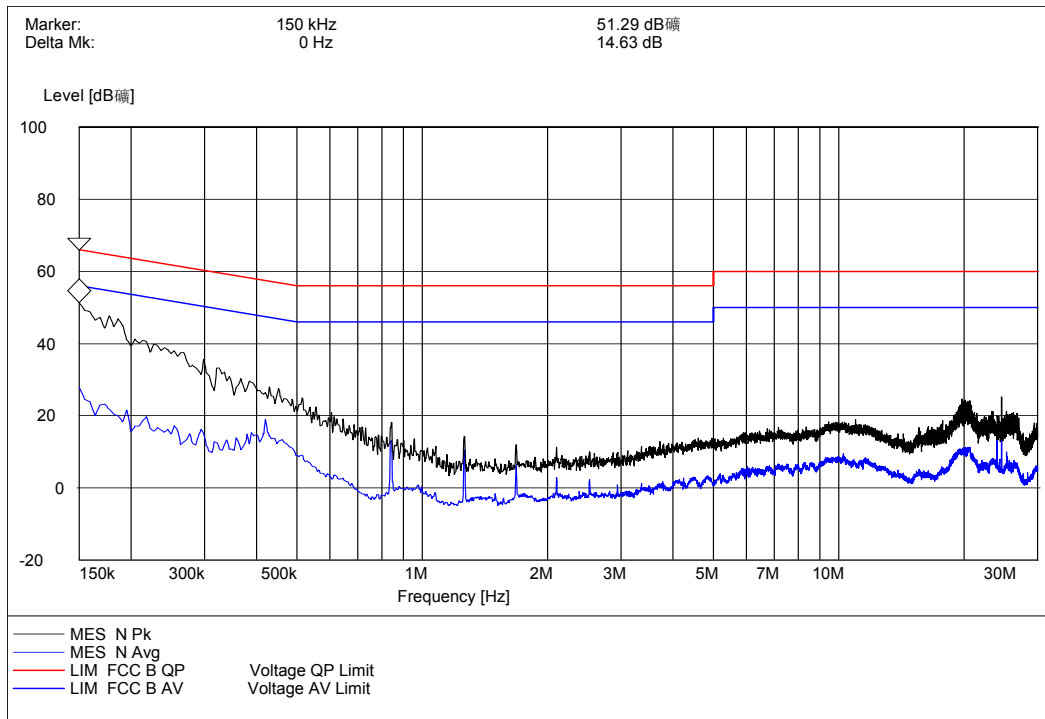

NOTE:

1. The lower limit shall apply at the transition frequencies.
2. The limit decreases linearly with the logarithm of the frequency in the range 0.15MHz to 0.50MHz.
3. The minimum margin value of quasi-peak and average level is over 3dB.

4.3 Radiated Emission Test

4.3.1 Limits of Radiated Emission

The field strength of radiated emissions from unintentional radiators at a distance of 3 meters shall not exceed the following values:

Frequency of Emission (MHz)	Field Strength (dB μ V/m) at 3m
30 - 88	40(QP)
88 -216	43.5(QP)
216 - 960	46.4(QP)
960-1000	54(QP)
Above 1000MHz	54(AV)/74(PK)

NOTE:

1. Field Strength (dB μ V/m)=20log Field Strength (μ V/m).
2. In the emission tables above, the tighter limit applies at the band edges.

4.3.2 Test Procedure

- a. The EUT was set 3 meters away from the interference-receiving antenna, which was mounted on the top of a variable-height antenna tower.
- b. The antenna is a broadband antenna, and its height is varied from one meter to four meter above the ground to determine the maximum value of the field strength. Both horizontal and vertical polarizations of the antenna are set to make the measurement.
- c. For each suspected emission, the EUT was arranged to its worst case and then the antenna was tuned to the heights from 1 to 4 meters and the ratable table was turned from 0 degrees to 360 degrees to find the maximum reading.
- d. The test-receiver system was set to Peak Detector Function and Specified Bandwidth with Maximum Hold Mode.
- e. If the emission level of the EUT in peak mode was 10 dB lower than the limit specified, then testing could be stopped and the peak values of the EUT would be reported. Otherwise the emission that did not have 10 dB margins would be retested one by one using the quasi-peak method.

4.3.3 Test Setup

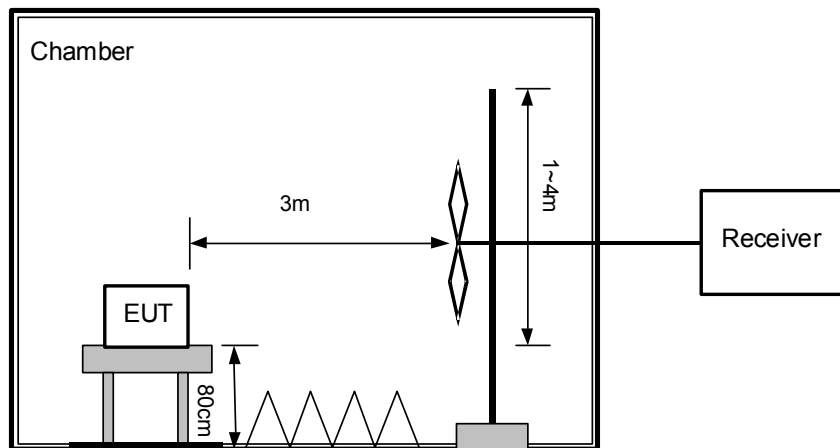
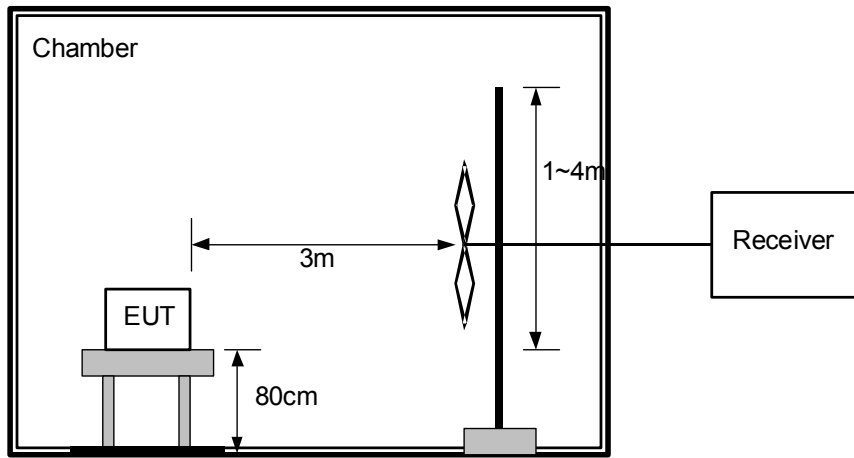

Note: The highest frequency of the internal sources of the EUT is 480 MHz, the measurement was made up to 2 GHz.

4.3.4 Test Results

Environment Condition:

Temperature: 23°C; Relative Humidity: 52%; Pressure: 101kPa

Test Date: 2015-10-17, 2015-10-24

Test Engineer: Chen Weixiong

Test Site: 10m Anechoic Chamber

Test Mode: Mode 1-6

1. Radiated Emission Test data (Standby Mode)

-Horizontal

Frequency (MHz)	QuasiPeak (dB μ V/m)	Bandwidth (kHz)	Antenna height (cm)	Polarity	Turntable position (deg)	Corr. (dB)	Margin (dB)	Limit (dB μ V/m)
39.640000	21.4	120.000	300.0	H	8.0	-15.5	18.6	40.0
199.200000	30.0	120.000	100.0	H	332.0	-16.0	13.5	43.5
274.160000	33.1	120.000	100.0	H	71.0	-12.5	12.9	46.0
399.440000	28.5	120.000	100.0	H	347.0	-9.7	17.5	46.0
598.120000	29.5	120.000	100.0	H	4.0	-6.2	16.5	46.0
890.360000	21.6	120.000	100.0	H	0.0	-1.4	24.4	46.0

Frequency (MHz)	Peak (dB μ V/m)	Peak limit (dB μ V/m)	Peak Margin (dB)	Turntable position (deg)	Ant. height (cm)	Polarity
1234.400000	32.8	74.0	41.2	0.0	100.0	H
1320.000000	33.5	74.0	40.5	0.0	100.0	H
1397.200000	32.6	74.0	41.4	0.0	100.0	H
1680.800000	33.1	74.0	40.9	0.0	100.0	H
1795.600000	35.1	74.0	38.9	0.0	100.0	H
1826.400000	34.1	74.0	39.9	0.0	100.0	H

Frequency (MHz)	Average dB μ V/m	Average limit (dB μ V/m)	Average Margin (dB)	Turntable position (deg)	Ant. height (cm)	Polarity
1234.400000	19.4	54.0	34.6	0.0	100.0	H
1320.000000	20.1	54.0	33.9	0.0	100.0	H
1397.200000	19.2	54.0	34.8	0.0	100.0	H
1680.800000	19.8	54.0	34.2	0.0	100.0	H
1795.600000	20.8	54.0	33.2	0.0	100.0	H
1826.400000	21.0	54.0	33.0	0.0	100.0	H

NOTE:

The minimum margin value is over 4dB.

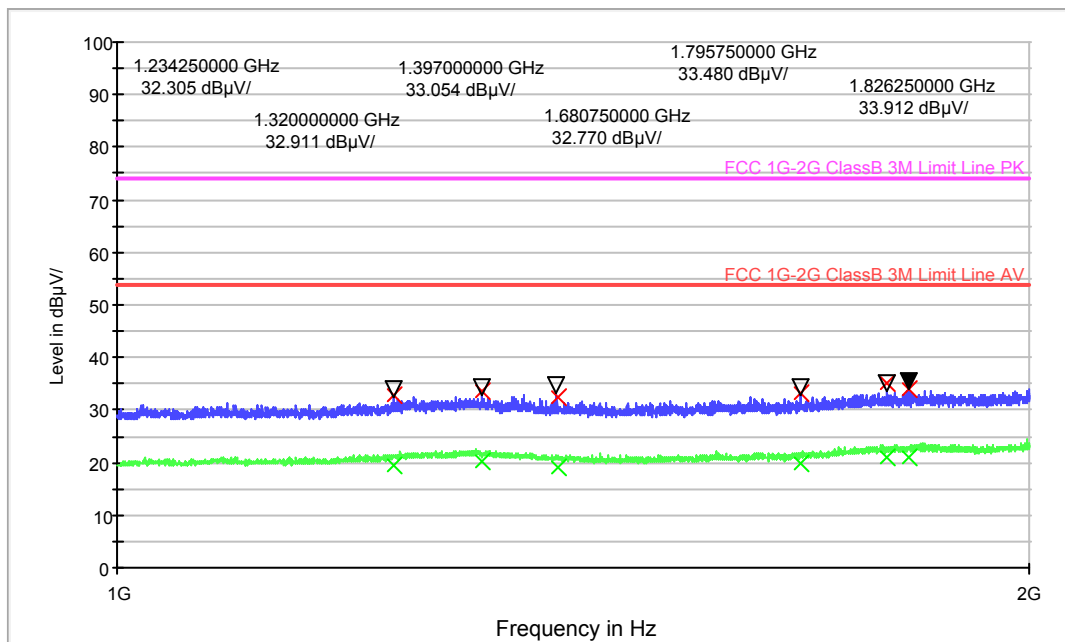
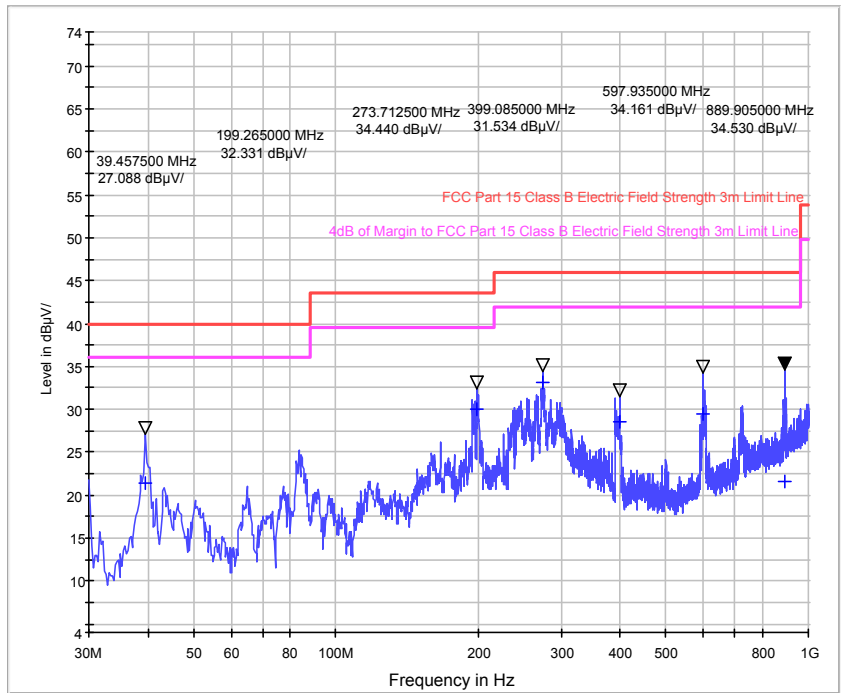

-Vertical

Frequency (MHz)	QuasiPeak (dB μ V/m)	Bandwidth (kHz)	Antenna height (cm)	Polarity	Turntable position (deg)	Corr. (dB)	Margin (dB)	Limit (dB μ V/m)
45.280000	27.7	120.000	100.0	V	356.0	-15.5	12.3	40.0
50.880000	26.7	120.000	100.0	V	119.0	-15.6	13.3	40.0
122.480000	25.8	120.000	100.0	V	271.0	-15.3	17.7	43.5
132.960000	25.2	120.000	100.0	V	5.0	-14.3	18.3	43.5
399.080000	29.2	120.000	100.0	V	0.0	-9.7	16.8	46.0
603.760000	26.6	120.000	100.0	V	149.0	-6.1	19.4	46.0

Frequency (MHz)	Peak (dB μ V/m)	Peak limit (dB μ V/m)	Peak Margin (dB)	Turntable position (deg)	Ant. height (cm)	Polarity
1242.000000	32.8	74.0	41.2	0.0	100.0	V
1316.000000	33.5	74.0	40.5	0.0	100.0	V
1385.600000	32.6	74.0	41.4	0.0	100.0	V
1758.800000	34.6	74.0	39.4	0.0	100.0	V
1864.800000	34.2	74.0	39.8	0.0	100.0	V
1967.200000	34.5	74.0	39.5	0.0	100.0	V

Frequency (MHz)	Average dB μ V/m	Average limit (dB μ V/m)	Average Margin (dB)	Turntable position (deg)	Ant. height (cm)	Polarity
1242.000000	19.7	54.0	34.30	0.0	100.0	V
1316.000000	20.2	54.0	33.80	0.0	100.0	V
1385.600000	19.3	54.0	34.70	0.0	100.0	V
1758.800000	20.6	54.0	33.40	0.0	100.0	V
1864.800000	21.0	54.0	33.00	0.0	100.0	V
1967.200000	21.2	54.0	32.80	0.0	100.0	V

NOTE:

The minimum margin value is over 4dB.

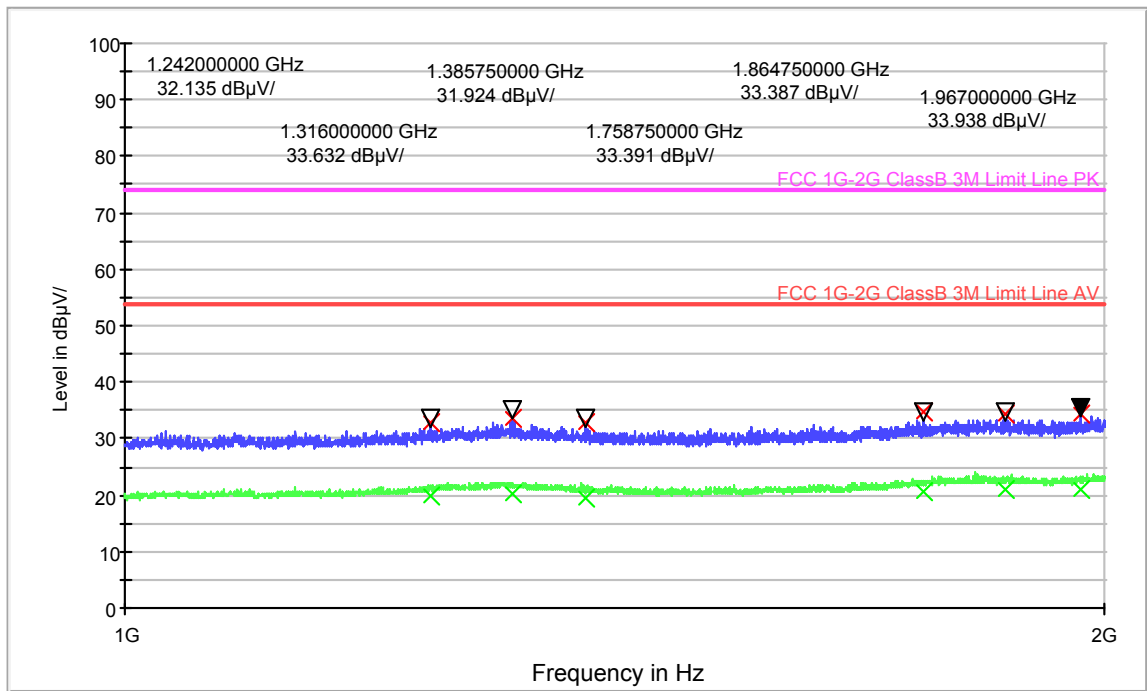
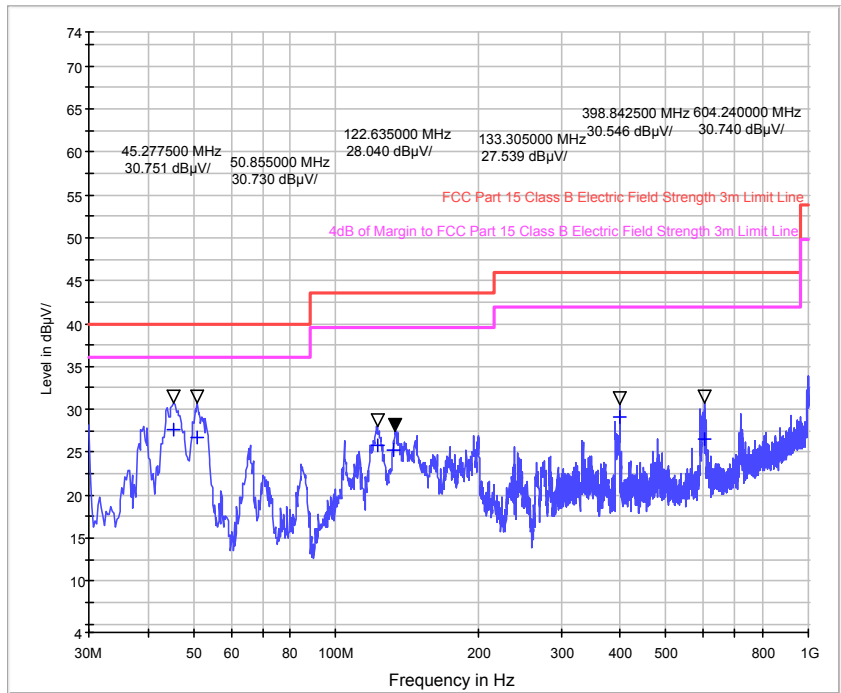

2. Radiated Emission Test data (Copy Mode)

-Horizontal

Frequency (MHz)	QuasiPeak (dB μ V/m)	Bandwidth (kHz)	Antenna height (cm)	Polarity	Turntable position (deg)	Corr. (dB)	Margin (dB)	Limit (dB μ V/m)
39.720000	21.9	120.000	300.0	H	0.0	-15.5	18.1	40.0
82.880000	21.0	120.000	300.0	H	32.0	-18.8	19.0	40.0
148.360000	19.7	120.000	300.0	H	353.0	-13.4	23.8	43.5
244.120000	30.5	120.000	100.0	H	32.0	-13.8	15.5	46.0
399.560000	31.1	120.000	100.0	H	0.0	-9.7	14.9	46.0
600.840000	28.6	120.000	100.0	H	0.0	-6.1	17.4	46.0

Frequency (MHz)	Peak (dB μ V/m)	Peak limit (dB μ V/m)	Peak Margin (dB)	Turntable position (deg)	Ant. height (cm)	Polarity
1036.000000	32.3	74.0	41.7	0.0	100.0	H
1129.600000	32.9	74.0	41.1	0.0	100.0	H
1333.600000	33.3	74.0	40.7	0.0	100.0	H
1445.200000	32.3	74.0	41.7	0.0	100.0	H
1782.400000	34.0	74.0	40.0	0.0	100.0	H
1995.200000	34.6	74.0	39.4	0.0	100.0	H

Frequency (MHz)	Average dB μ V/m	Average limit (dB μ V/m)	Average Margin (dB)	Turntable position (deg)	Ant. height (cm)	Polarity
1036.000000	18.5	54.0	35.5	0.0	100.0	H
1129.600000	18.6	54.0	35.4	0.0	100.0	H
1333.600000	19.8	54.0	34.2	0.0	100.0	H
1445.200000	18.9	54.0	35.1	0.0	100.0	H
1782.400000	20.9	54.0	33.1	0.0	100.0	H
1995.200000	21.4	54.0	32.6	0.0	100.0	H

NOTE:

The minimum margin value is over 4dB.

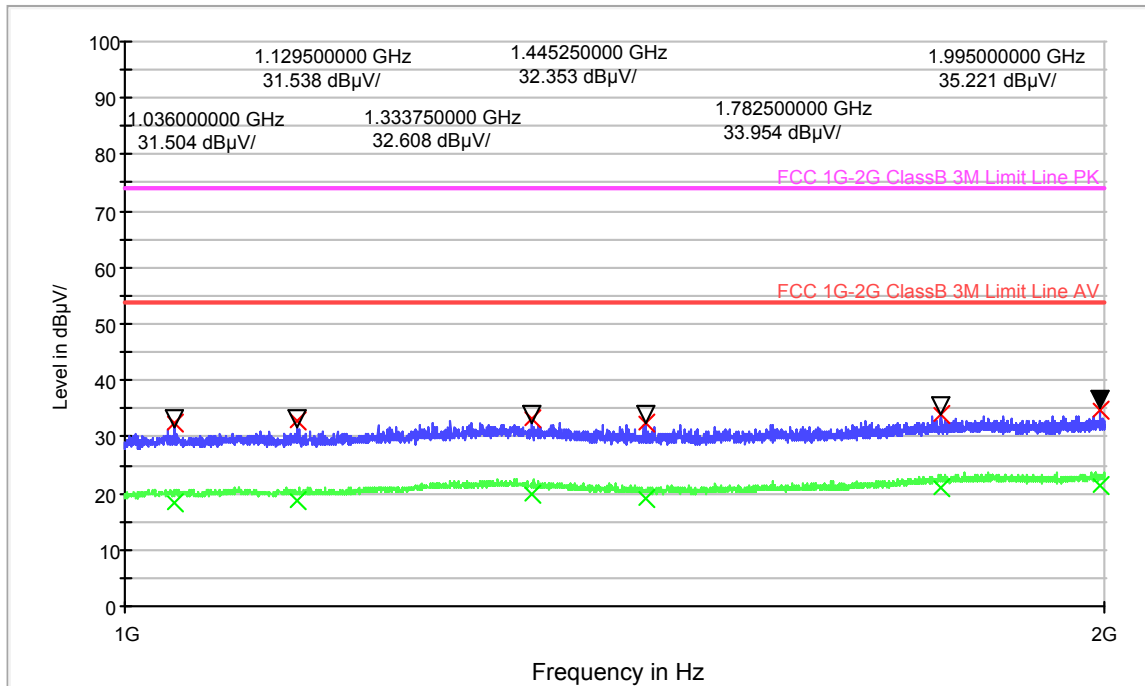
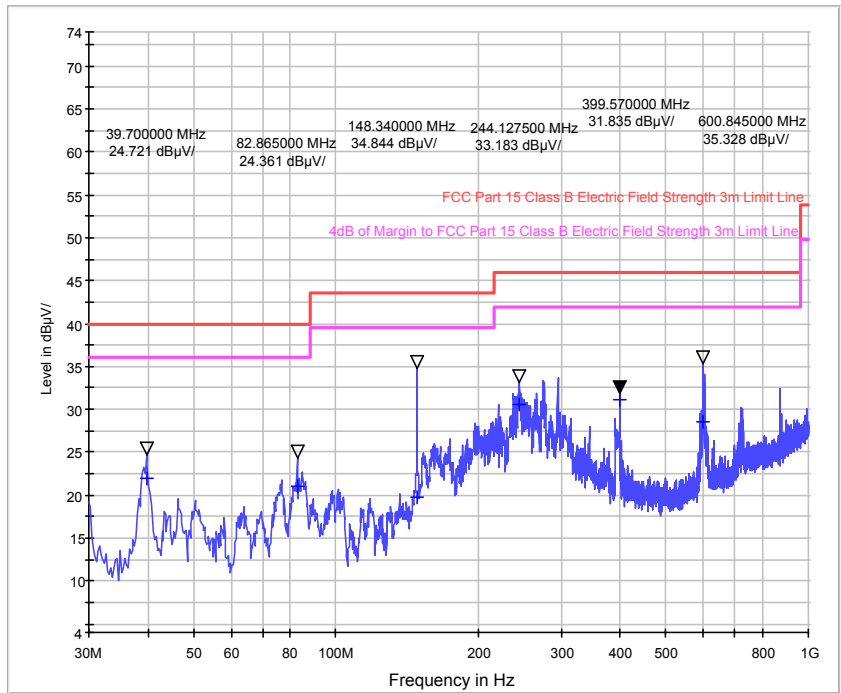

-Vertical

Frequency (MHz)	QuasiPeak (dB μ V/m)	Bandwidth (kHz)	Antenna height (cm)	Polarity	Turntable position (deg)	Corr. (dB)	Margin (dB)	Limit (dB μ V/m)
38.960000	26.6	120.000	100.0	V	0.0	-15.6	13.4	40.0
50.120000	26.6	120.000	100.0	V	0.0	-15.6	13.4	40.0
123.600000	25.6	120.000	100.0	V	118.0	-15.2	17.9	43.5
245.080000	24.1	120.000	100.0	V	327.0	-13.7	21.9	46.0
391.080000	25.9	120.000	100.0	V	32.0	-9.9	20.1	46.0
599.640000	24.6	120.000	100.0	V	354.0	-6.1	21.4	46.0

Frequency (MHz)	Peak (dB μ V/m)	Peak limit (dB μ V/m)	Peak Margin (dB)	Turntable position (deg)	Ant. height (cm)	Polarity
1032.400000	32.2	74.0	41.8	0.0	100.0	V
1237.200000	33.4	74.0	40.6	0.0	100.0	V
1296.400000	34.1	74.0	39.9	0.0	100.0	V
1582.400000	33.2	74.0	40.8	0.0	100.0	V
1845.600000	34.6	74.0	39.4	0.0	100.0	V
1964.000000	35.3	74.0	38.7	0.0	100.0	V

Frequency (MHz)	Average dB μ V/m	Average limit (dB μ V/m)	Average Margin (dB)	Turntable position (deg)	Ant. height (cm)	Polarity
1032.400000	18.5	54.0	35.5	0.0	100.0	V
1237.200000	19.5	54.0	34.5	0.0	100.0	V
1296.400000	20.1	54.0	33.9	0.0	100.0	V
1582.400000	19.4	54.0	34.6	0.0	100.0	V
1845.600000	21.1	54.0	32.9	0.0	100.0	V
1964.000000	21.1	54.0	32.9	0.0	100.0	V

NOTE:

The minimum margin value is over 4dB.

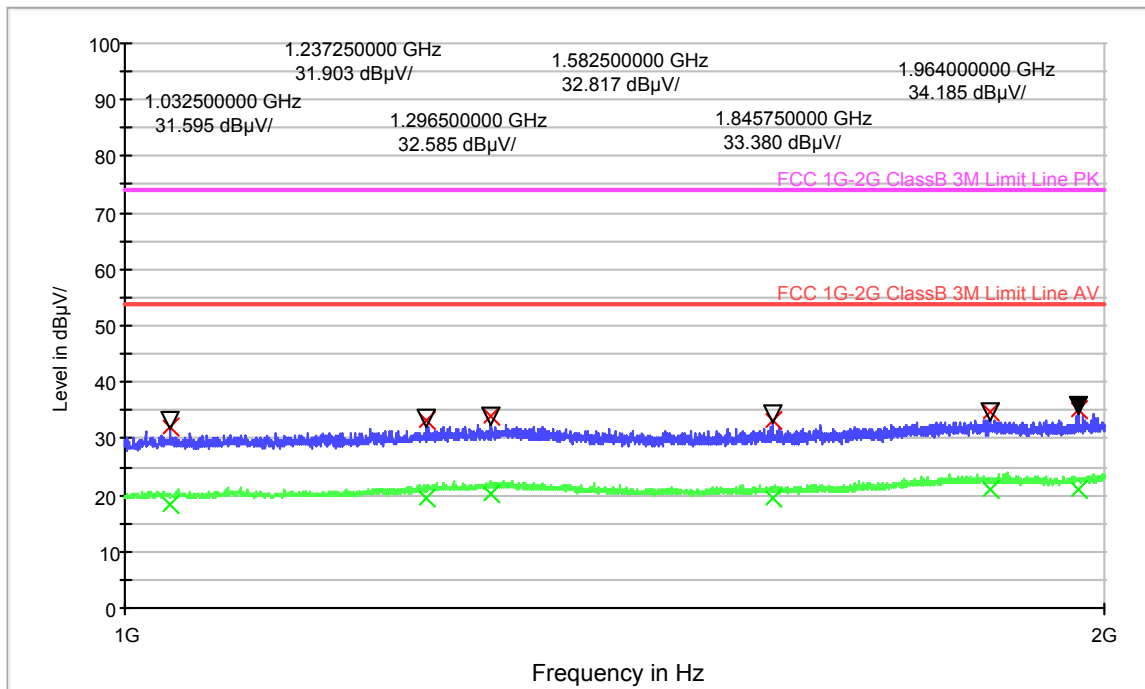
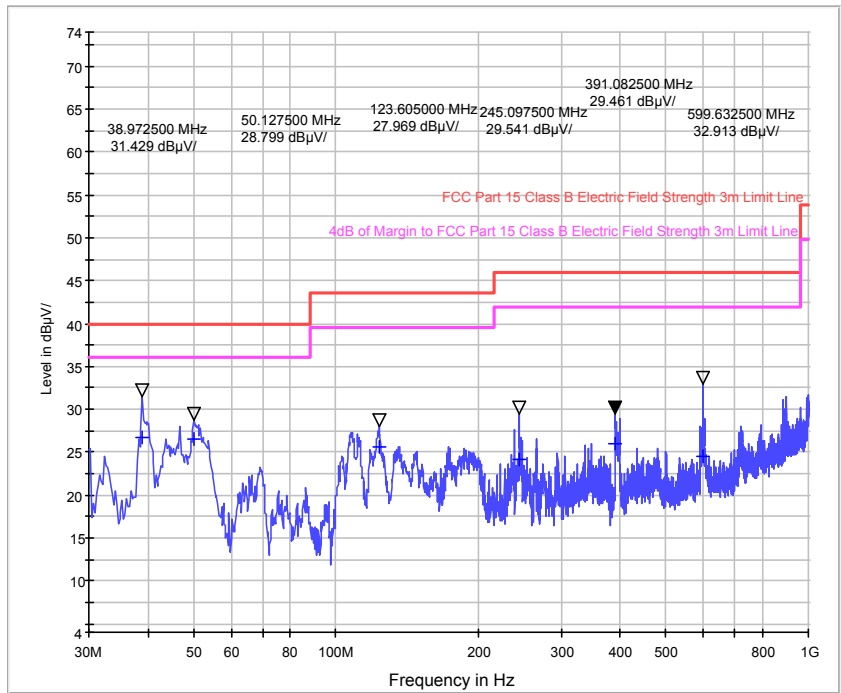

3. Radiated Emission Test data (USB Print Mode)

-Horizontal

Frequency (MHz)	QuasiPeak (dB μ V/m)	Bandwidth (kHz)	Antenna height (cm)	Polarity	Turntable position (deg)	Corr. (dB)	Margin (dB)	Limit (dB μ V/m)
39.320000	20.4	120.000	300.0	H	351.0	-15.6	19.6	40.0
84.320000	23.8	120.000	300.0	H	5.0	-18.7	16.2	40.0
196.120000	27.9	120.000	100.0	H	0.0	-15.8	15.6	43.5
264.320000	31.7	120.000	100.0	H	332.0	-12.9	14.3	46.0
599.600000	29.6	120.000	100.0	H	22.0	-6.1	16.4	46.0
720.520000	20.5	120.000	100.0	H	356.0	-4.2	25.6	46.0

Frequency (MHz)	Peak (dB μ V/m)	Peak limit (dB μ V/m)	Peak Margin (dB)	Turntable position (deg)	Ant. height (cm)	Polarity
1230.400000	33.0	74.0	41.0	0.0	100.0	H
1301.600000	34.0	74.0	40.0	0.0	100.0	H
1354.000000	33.2	74.0	40.8	0.0	100.0	H
1636.400000	32.8	74.0	41.2	0.0	100.0	H
1785.600000	34.4	74.0	39.6	0.0	100.0	H
1877.600000	34.7	74.0	39.3	0.0	100.0	H

Frequency (MHz)	Average dB μ V/m	Average limit (dB μ V/m)	Average Margin (dB)	Turntable position (deg)	Ant. height (cm)	Polarity
1230.400000	19.4	54.0	34.6	0.0	100.0	H
1301.600000	20.2	54.0	33.8	0.0	100.0	H
1354.000000	19.8	54.0	34.2	0.0	100.0	H
1636.400000	19.5	54.0	34.5	0.0	100.0	H
1785.600000	20.9	54.0	33.1	0.0	100.0	H
1877.600000	20.9	54.0	33.1	0.0	100.0	H

NOTE:

The minimum margin value is over 4dB.

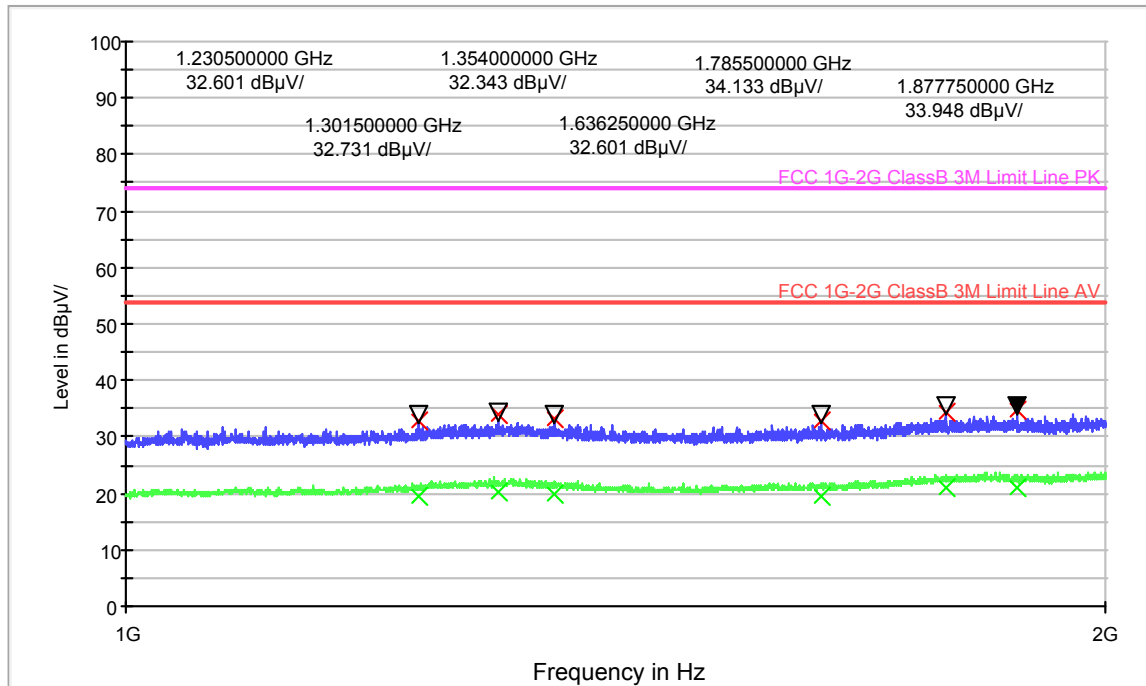
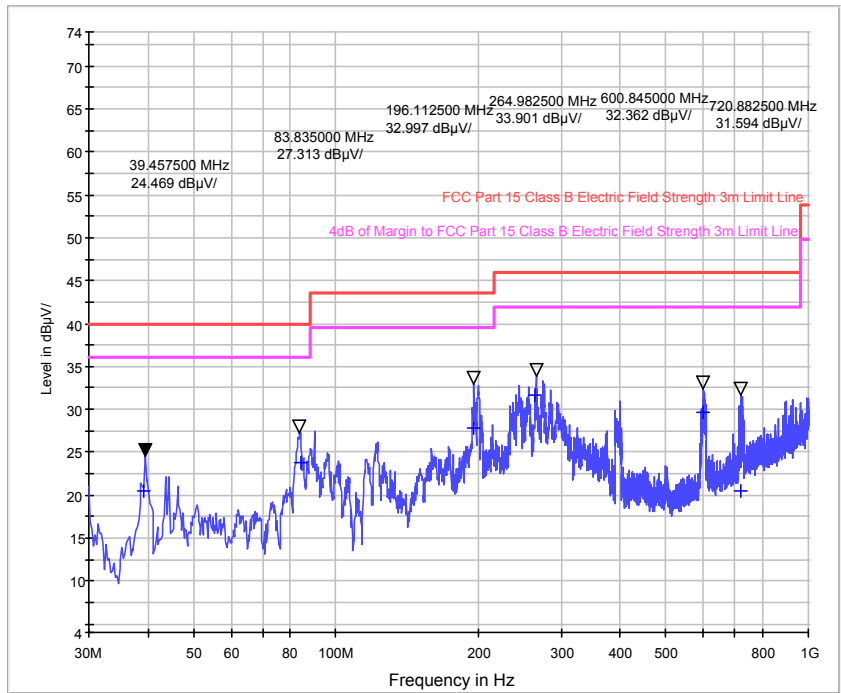

-Vertical

Frequency (MHz)	QuasiPeak (dB μ V/m)	Bandwidth (kHz)	Antenna height (cm)	Polarity	Turntable position (deg)	Corr. (dB)	Margin (dB)	Limit (dB μ V/m)
39.800000	26.3	120.000	100.0	V	188.0	-15.5	13.7	40.0
50.320000	24.2	120.000	100.0	V	0.0	-15.6	15.8	40.0
121.920000	25.4	120.000	100.0	V	357.0	-15.3	18.1	43.5
399.320000	21.6	120.000	100.0	V	0.0	-9.7	24.4	46.0
602.360000	28.4	120.000	100.0	V	0.0	-6.1	17.6	46.0
995.680000	30.6	120.000	100.0	V	10.0	0.2	23.3	53.9

Frequency (MHz)	Peak (dB μ V/m)	Peak limit (dB μ V/m)	Peak Margin (dB)	Turntable position (deg)	Ant. height (cm)	Polarity
1232.800000	33.3	74.0	40.7	0.0	100.0	V
1308.800000	33.7	74.0	40.3	0.0	100.0	V
1343.600000	33.4	74.0	40.6	0.0	100.0	V
1483.200000	32.6	74.0	41.4	0.0	100.0	V
1802.800000	34.3	74.0	39.7	0.0	100.0	V
1887.200000	34.4	74.0	39.6	0.0	100.0	V

Frequency (MHz)	Average dB μ V/m	Average limit (dB μ V/m)	Average Margin (dB)	Turntable position (deg)	Ant. height (cm)	Polarity
1232.800000	19.4	54.0	34.6	0.0	100.0	V
1308.800000	20.3	54.0	33.7	0.0	100.0	V
1343.600000	19.8	54.0	34.2	0.0	100.0	V
1483.200000	19.0	54.0	35.0	0.0	100.0	V
1802.800000	20.9	54.0	33.1	0.0	100.0	V
1887.200000	20.9	54.0	33.1	0.0	100.0	V

NOTE:

The minimum margin value is over 4dB.

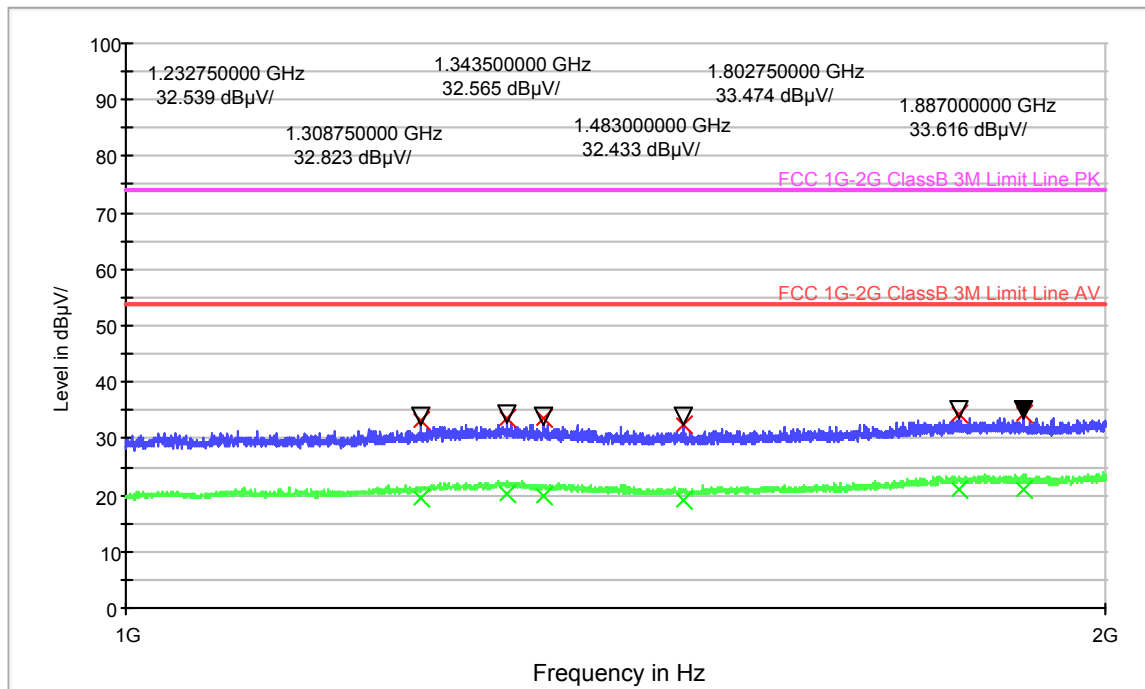
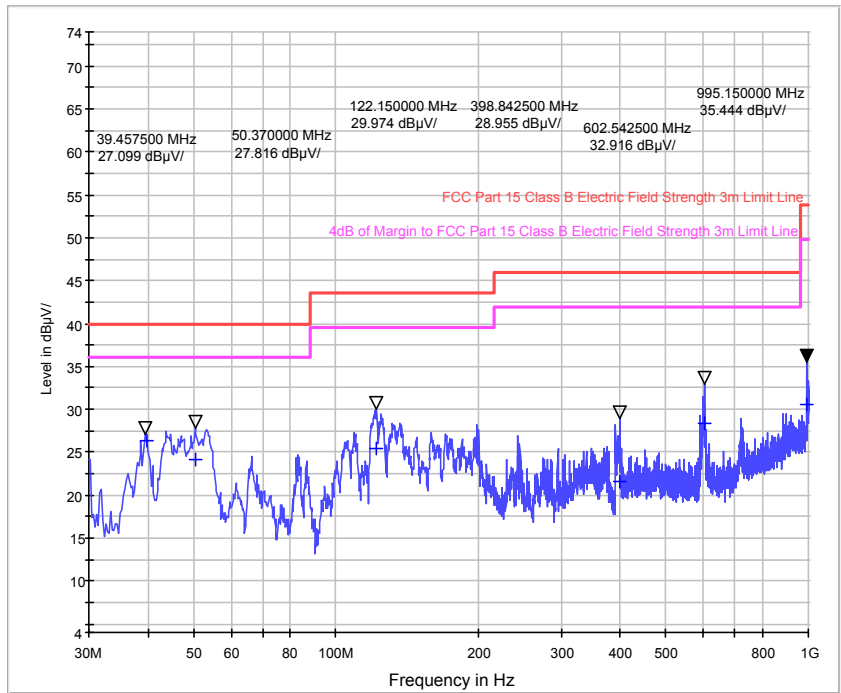

4. Radiated Emission Test data (WiFi Print Mode)

-Horizontal

Frequency (MHz)	QuasiPeak (dB μ V/m)	Bandwidth (kHz)	Antenna height (cm)	Polarity	Turntable position (deg)	Corr. (dB)	Margin (dB)	Limit (dB μ V/m)
39.480000	22.2	120.000	300.0	H	4.0	-15.5	17.8	40.0
83.240000	22.5	120.000	300.0	H	350.0	-18.8	17.5	40.0
236.720000	27.7	120.000	100.0	H	216.0	-14.0	18.3	46.0
275.320000	32.9	120.000	100.0	H	121.0	-12.4	13.1	46.0
601.600000	29.0	120.000	100.0	H	350.0	-6.1	17.0	46.0
724.520000	27.6	120.000	100.0	H	0.0	-4.1	18.4	46.0

Frequency (MHz)	Peak (dB μ V/m)	Peak limit (dB μ V/m)	Peak Margin (dB)	Turntable position (deg)	Ant. height (cm)	Polarity
1073.600000	32.2	74.0	41.8	0.0	100.0	H
1230.400000	32.8	74.0	41.2	0.0	100.0	H
1352.800000	33.3	74.0	40.7	0.0	100.0	H
1475.200000	32.2	74.0	41.8	0.0	100.0	H
1823.200000	34.6	74.0	39.4	0.0	100.0	H
1967.600000	34.3	74.0	39.7	0.0	100.0	H

Frequency (MHz)	Average dB μ V/m	Average limit (dB μ V/m)	Average Margin (dB)	Turntable position (deg)	Ant. height (cm)	Polarity
1073.600000	18.7	54.0	35.3	0.0	100.0	H
1230.400000	19.4	54.0	34.6	0.0	100.0	H
1352.800000	19.8	54.0	34.2	0.0	100.0	H
1475.200000	19.0	54.0	35.0	0.0	100.0	H
1823.200000	21.0	54.0	33.0	0.0	100.0	H
1967.600000	21.1	54.0	32.9	0.0	100.0	H

NOTE:

The minimum margin value is over 4dB.

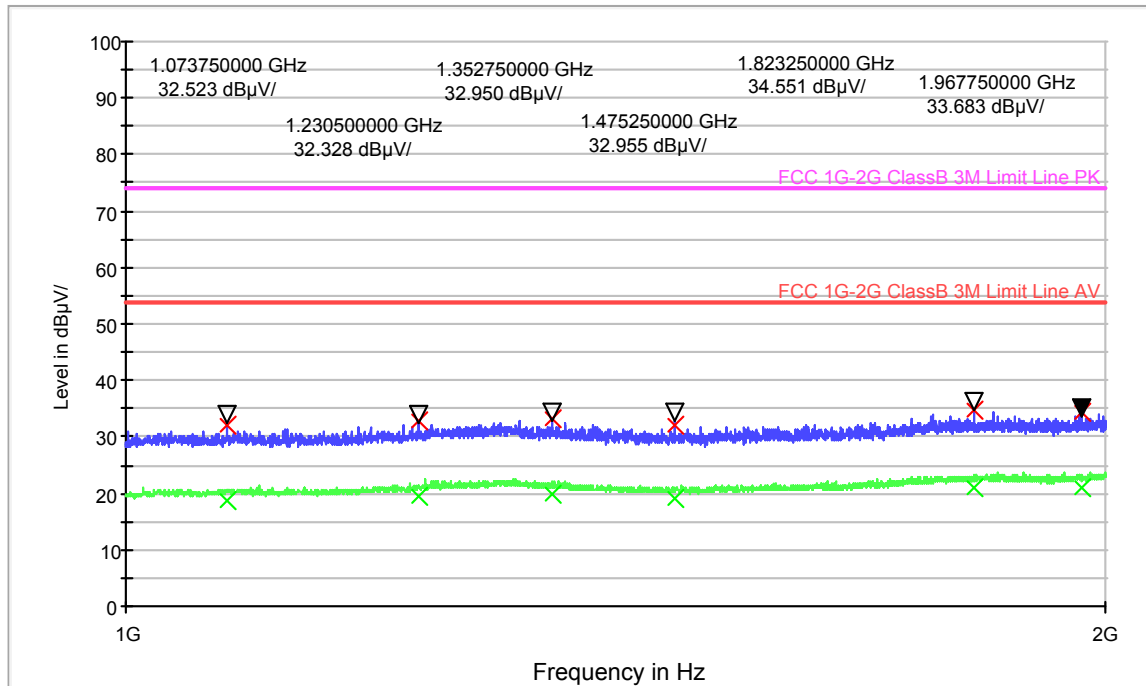
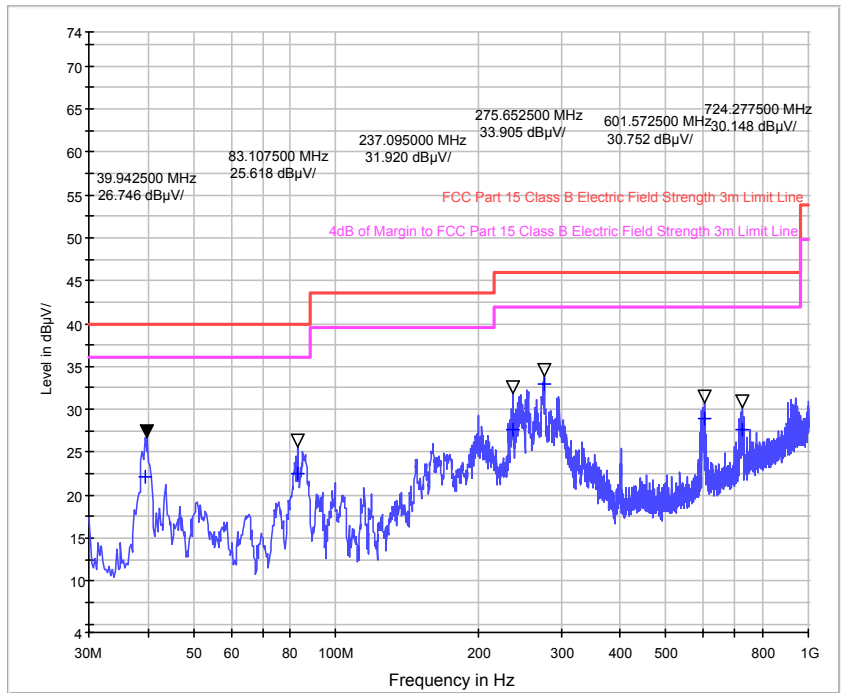

-Vertical

Frequency (MHz)	QuasiPeak (dB μ V/m)	Bandwidth (kHz)	Antenna height (cm)	Polarity	Turntable position (deg)	Corr. (dB)	Margin (dB)	Limit (dB μ V/m)
30.000000	25.5	120.000	100.0	V	29.0	-16.2	14.5	40.0
39.360000	26.4	120.000	100.0	V	322.0	-15.6	13.6	40.0
53.360000	25.4	120.000	100.0	V	0.0	-15.6	14.6	40.0
121.800000	25.6	120.000	100.0	V	252.0	-15.3	17.9	43.5
243.040000	23.5	120.000	100.0	V	3.0	-13.8	22.5	46.0
590.280000	26.7	120.000	100.0	V	322.0	-6.4	19.3	46.0

Frequency (MHz)	Peak (dB μ V/m)	Peak limit (dB μ V/m)	Peak Margin (dB)	Turntable position (deg)	Ant. height (cm)	Polarity
1209.200000	32.2	74.0	41.8	0.0	100.0	V
1299.600000	33.4	74.0	40.6	0.0	100.0	V
1399.200000	32.8	74.0	41.2	0.0	100.0	V
1617.600000	32.9	74.0	41.1	0.0	100.0	V
1809.200000	34.5	74.0	39.5	0.0	100.0	V
1883.600000	34.9	74.0	39.1	0.0	100.0	V

Frequency (MHz)	Average dB μ V/m	Average limit (dB μ V/m)	Average Margin (dB)	Turntable position (deg)	Ant. height (cm)	Polarity
1209.200000	19.1	54.0	34.9	0.0	100.0	V
1299.600000	20.2	54.0	33.8	0.0	100.0	V
1399.200000	19.3	54.0	34.7	0.0	100.0	V
1617.600000	19.4	54.0	34.6	0.0	100.0	V
1809.200000	20.9	54.0	33.1	0.0	100.0	V
1883.600000	21.0	54.0	33.0	0.0	100.0	V

NOTE:

The minimum margin value is over 4dB.

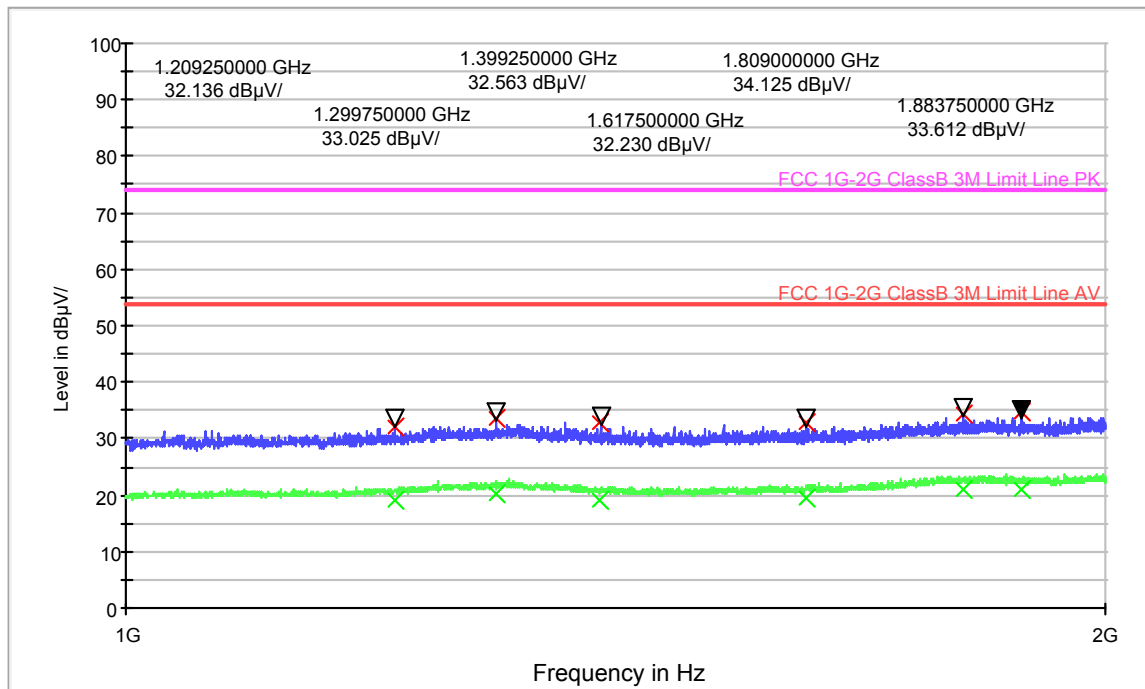
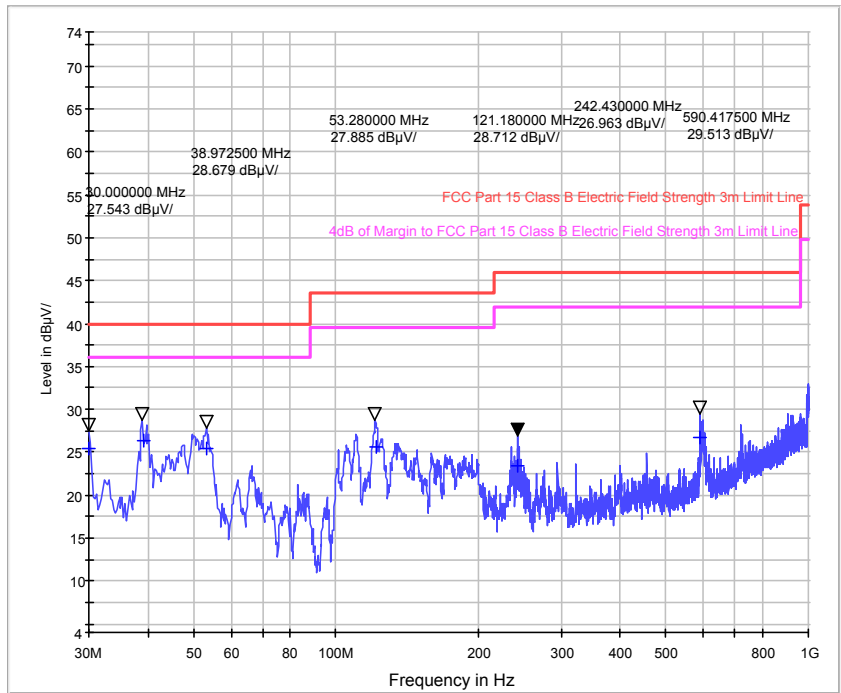

5. Radiated Emission Test data (USB Scan Mode)

-Horizontal

Frequency (MHz)	QuasiPeak (dB μ V/m)	Bandwidth (kHz)	Antenna height (cm)	Polarity	Turntable position (deg)	Corr. (dB)	Margin (dB)	Limit (dB μ V/m)
39.960000	21.3	120.000	300.0	H	36.0	-15.5	18.7	40.0
198.880000	30.3	120.000	100.0	H	205.0	-16.0	13.2	43.5
247.040000	28.1	120.000	100.0	H	192.0	-13.7	17.9	46.0
399.560000	29.1	120.000	100.0	H	0.0	-9.7	16.9	46.0
597.200000	29.3	120.000	100.0	H	157.0	-6.2	16.7	46.0
721.840000	29.5	120.000	100.0	H	58.0	-4.2	16.5	46.0

Frequency (MHz)	Peak (dB μ V/m)	Peak limit (dB μ V/m)	Peak Margin (dB)	Turntable position (deg)	Ant. height (cm)	Polarity
1087.200000	32.4	74.0	41.6	0.0	100.0	H
1242.800000	33.3	74.0	40.7	0.0	100.0	H
1315.200000	33.5	74.0	40.5	0.0	100.0	H
1636.800000	32.7	74.0	41.3	0.0	100.0	H
1726.800000	33.5	74.0	40.5	0.0	100.0	H
1859.600000	34.9	74.0	39.1	0.0	100.0	H

Frequency (MHz)	Average dB μ V/m	Average limit (dB μ V/m)	Average Margin (dB)	Turntable position (deg)	Ant. height (cm)	Polarity
1087.200000	18.7	54.0	35.3	0.0	100.0	H
1242.800000	19.7	54.0	34.3	0.0	100.0	H
1315.200000	20.2	54.0	33.8	0.0	100.0	H
1636.800000	19.5	54.0	34.5	0.0	100.0	H
1726.800000	20.2	54.0	33.8	0.0	100.0	H
1859.600000	21.0	54.0	33.0	0.0	100.0	H

NOTE:

The minimum margin value is over 4dB.

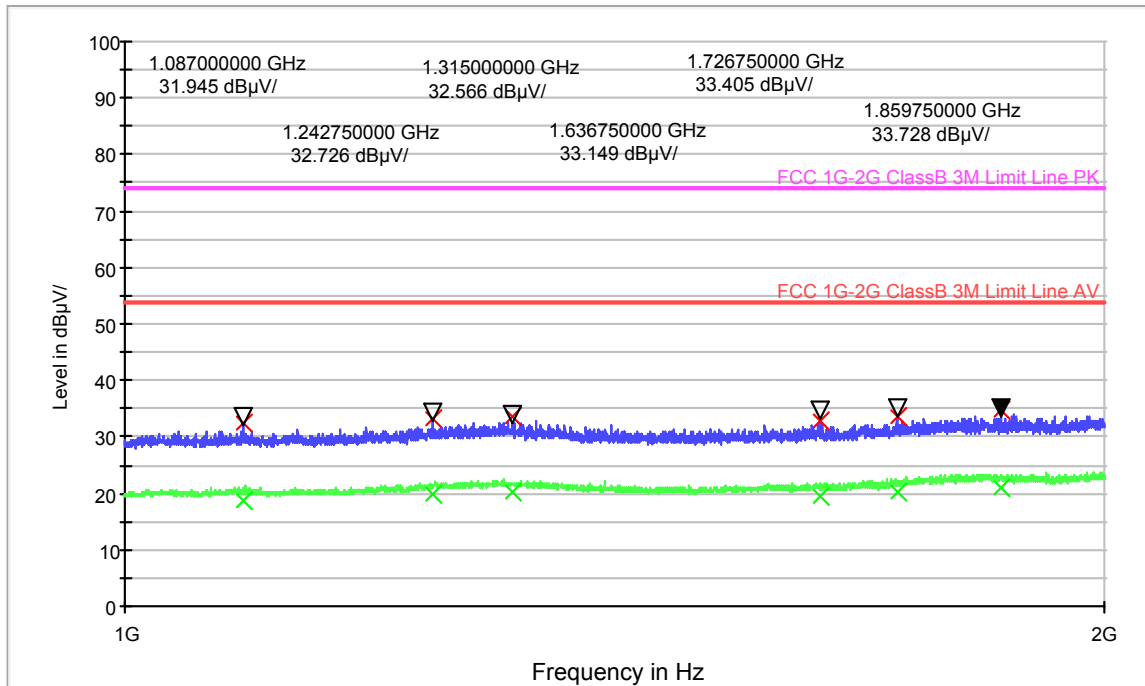
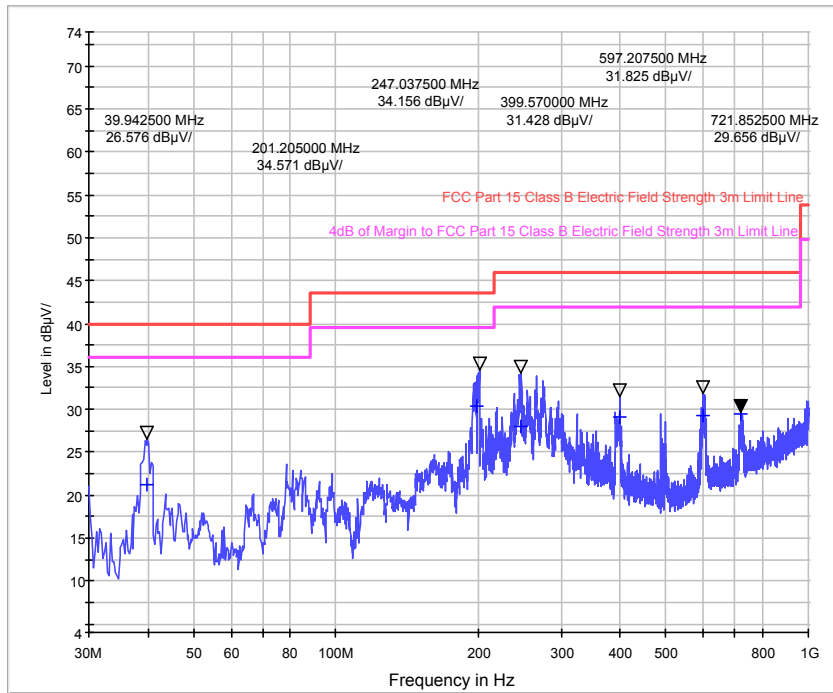

-Vertical

Frequency (MHz)	QuasiPeak (dB μ V/m)	Bandwidth (kHz)	Antenna height (cm)	Polarity	Turntable position (deg)	Corr. (dB)	Margin (dB)	Limit (dB μ V/m)
38.720000	25.0	120.000	100.0	V	0.0	-15.6	15.0	40.0
44.080000	25.7	120.000	100.0	V	0.0	-15.4	14.3	40.0
122.120000	26.6	120.000	100.0	V	351.0	-15.3	16.9	43.5
133.800000	26.0	120.000	100.0	V	0.0	-14.3	17.5	43.5
200.480000	24.1	120.000	100.0	V	4.0	-16.0	19.4	43.5
589.440000	26.3	120.000	100.0	V	357.0	-6.5	19.7	46.0

Frequency (MHz)	Peak (dB μ V/m)	Peak limit (dB μ V/m)	Peak Margin (dB)	Turntable position (deg)	Ant. height (cm)	Polarity
1075.200000	31.8	74.0	42.2	0.0	100.0	V
1193.600000	32.3	74.0	41.7	0.0	100.0	V
1371.600000	32.6	74.0	41.4	0.0	100.0	V
1448.000000	32.5	74.0	41.5	0.0	100.0	V
1821.200000	35.2	74.0	38.8	0.0	100.0	V
1962.400000	34.6	74.0	39.4	0.0	100.0	V

Frequency (MHz)	Average dB μ V/m	Average limit (dB μ V/m)	Average Margin (dB)	Turntable position (deg)	Ant. height (cm)	Polarity
1075.200000	18.7	54.0	35.3	0.0	100.0	V
1193.600000	19.1	54.0	34.9	0.0	100.0	V
1371.600000	19.6	54.0	34.4	0.0	100.0	V
1448.000000	19.0	54.0	35.0	0.0	100.0	V
1821.200000	21.0	54.0	33.0	0.0	100.0	V
1962.400000	21.1	54.0	32.9	0.0	100.0	V

NOTE:

The minimum margin value is over 4dB.

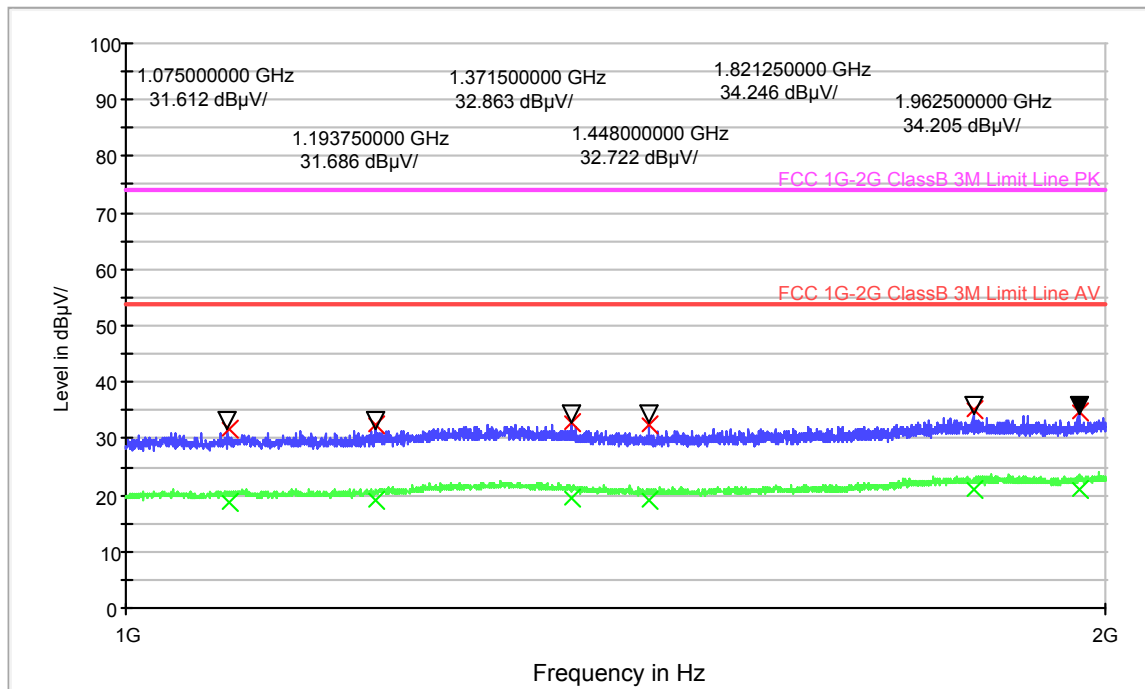
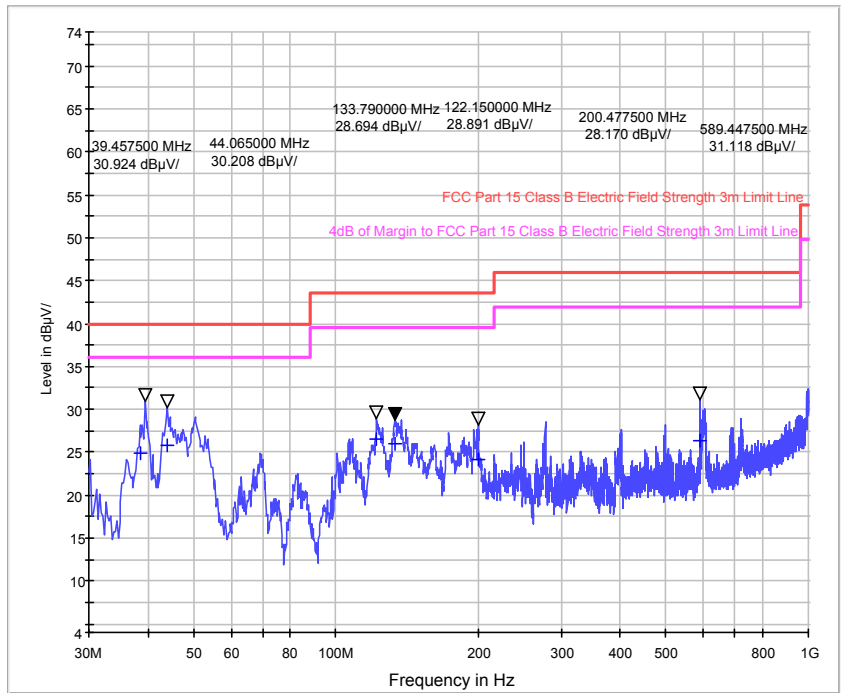

6. Radiated Emission Test data (WiFi Scan Mode)

-Horizontal

Frequency (MHz)	QuasiPeak (dB μ V/m)	Bandwidth (kHz)	Antenna height (cm)	Polarity	Turntable position (deg)	Corr. (dB)	Margin (dB)	Limit (dB μ V/m)
39.440000	21.0	120.000	300.0	H	128.0	-15.5	19.0	40.0
200.720000	27.4	120.000	100.0	H	40.0	-16.0	16.1	43.5
246.320000	29.0	120.000	100.0	H	219.0	-13.7	17.0	46.0
274.440000	28.3	120.000	100.0	H	316.0	-12.5	17.7	46.0
596.760000	22.5	120.000	300.0	H	0.0	-6.2	23.5	46.0
720.160000	19.9	120.000	100.0	H	356.0	-4.2	26.1	46.0

Frequency (MHz)	Peak (dB μ V/m)	Peak limit (dB μ V/m)	Peak Margin (dB)	Turntable position (deg)	Ant. height (cm)	Polarity
1247.600000	33.2	74.0	40.8	0.0	100.0	H
1314.000000	33.9	74.0	40.1	0.0	100.0	H
1327.200000	33.2	74.0	40.8	0.0	100.0	H
1464.400000	32.3	74.0	41.7	0.0	100.0	H
1850.400000	34.5	74.0	39.5	0.0	100.0	H
1997.200000	34.5	74.0	39.5	0.0	100.0	H

Frequency (MHz)	Average dB μ V/m	Average limit (dB μ V/m)	Average Margin (dB)	Turntable position (deg)	Ant. height (cm)	Polarity
1247.600000	19.8	54.0	34.2	0.0	100.0	H
1314.000000	20.2	54.0	33.8	0.0	100.0	H
1327.200000	20.0	54.0	34.0	0.0	100.0	H
1464.400000	18.9	54.0	35.1	0.0	100.0	H
1850.400000	21.1	54.0	32.9	0.0	100.0	H
1997.200000	21.4	54.0	32.6	0.0	100.0	H

NOTE:

The minimum margin value is over 4dB.

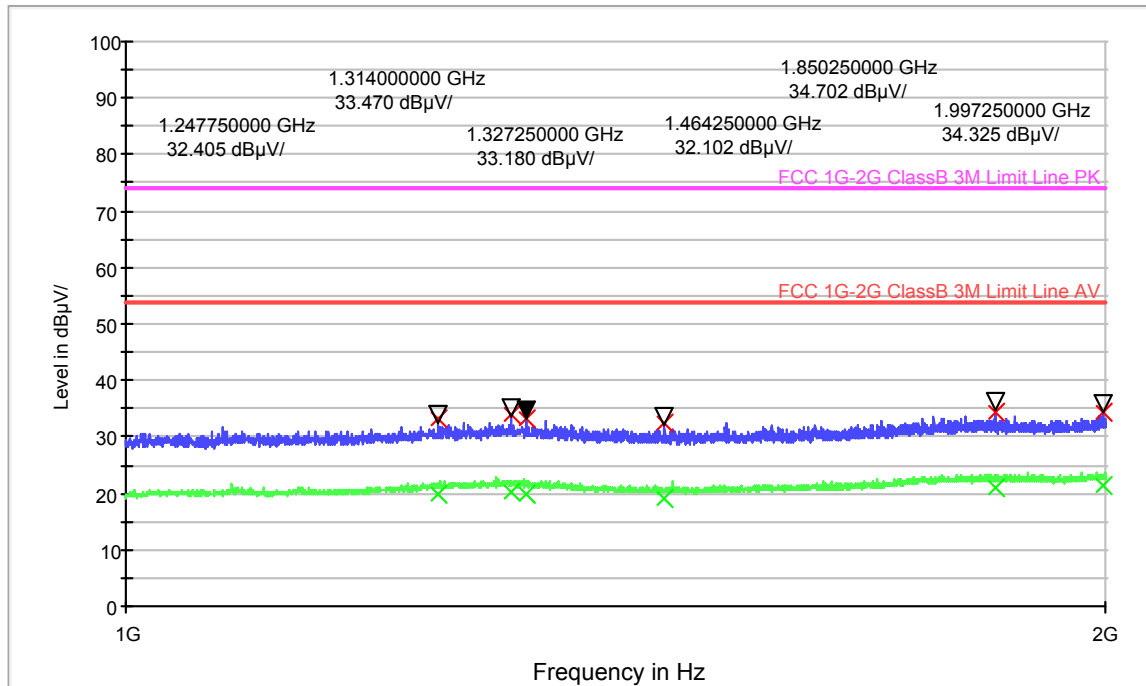
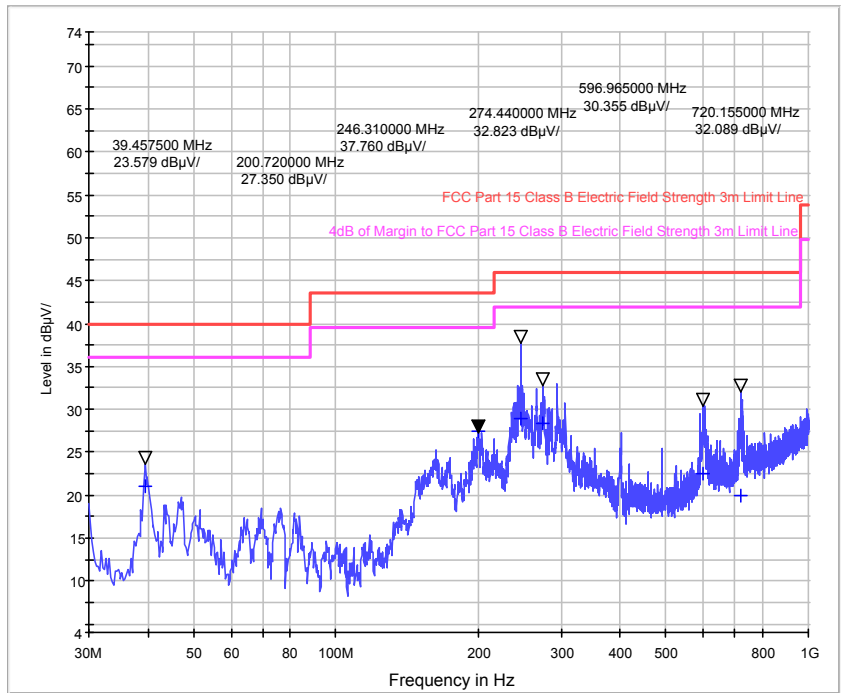

-Vertical

Frequency (MHz)	QuasiPeak (dB μ V/m)	Bandwidth (kHz)	Antenna height (cm)	Polarity	Turntable position (deg)	Corr. (dB)	Margin (dB)	Limit (dB μ V/m)
38.920000	25.2	120.000	100.0	V	185.0	-15.6	14.8	40.0
50.840000	25.8	120.000	100.0	V	0.0	-15.6	14.2	40.0
69.520000	23.8	120.000	100.0	V	0.0	-16.7	16.2	40.0
123.360000	24.1	120.000	100.0	V	0.0	-15.2	19.4	43.5
482.520000	19.0	120.000	100.0	V	0.0	-8.5	27.0	46.0
589.920000	25.0	120.000	100.0	V	0.0	-6.5	21.0	46.0

Frequency (MHz)	Peak (dB μ V/m)	Peak limit (dB μ V/m)	Peak Margin (dB)	Turntable position (deg)	Ant. height (cm)	Polarity
1183.200000	32.0	74.0	42.0	0.0	100.0	V
1266.400000	33.3	74.0	40.7	0.0	100.0	V
1314.800000	33.3	74.0	40.7	0.0	100.0	V
1656.400000	32.9	74.0	41.1	0.0	100.0	V
1752.000000	34.0	74.0	40.0	0.0	100.0	V
1974.800000	34.7	74.0	39.3	0.0	100.0	V

Frequency (MHz)	Average dB μ V/m	Average limit (dB μ V/m)	Average Margin (dB)	Turntable position (deg)	Ant. height (cm)	Polarity
1183.200000	18.8	54.0	35.2	0.0	100.0	V
1266.400000	19.9	54.0	34.1	0.0	100.0	V
1314.800000	20.3	54.0	33.7	0.0	100.0	V
1656.400000	19.5	54.0	34.5	0.0	100.0	V
1752.000000	20.6	54.0	33.4	0.0	100.0	V
1974.800000	21.2	54.0	32.8	0.0	100.0	V

NOTE:

The minimum margin value is over 4dB.

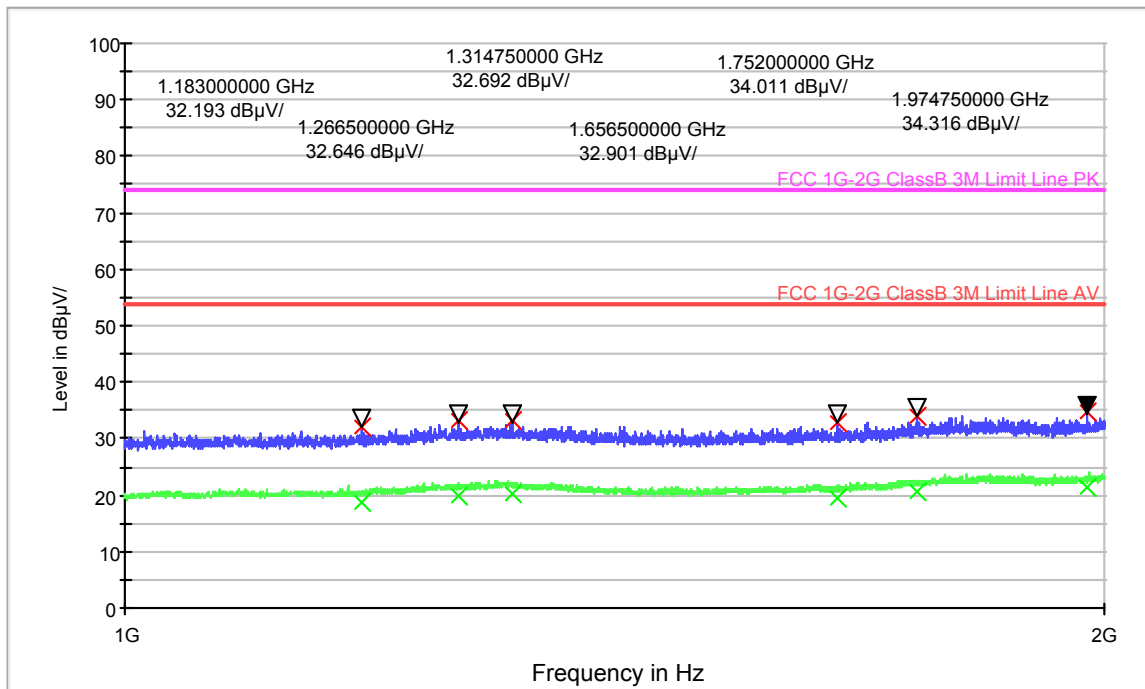
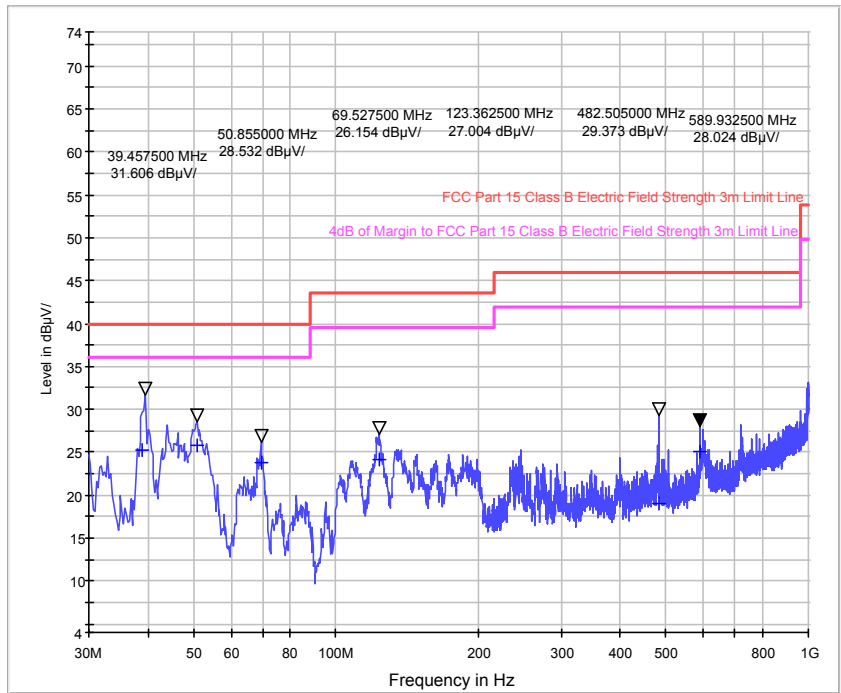

Appendix I: Photographs of the EUT

1. Appearance







2. Inside



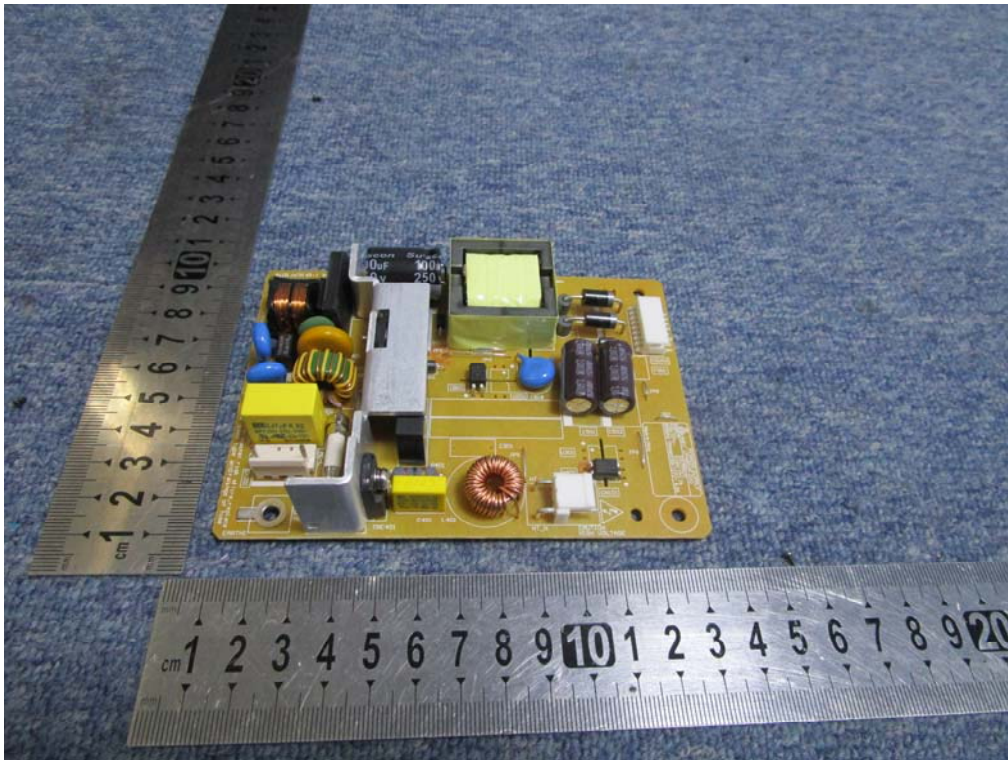

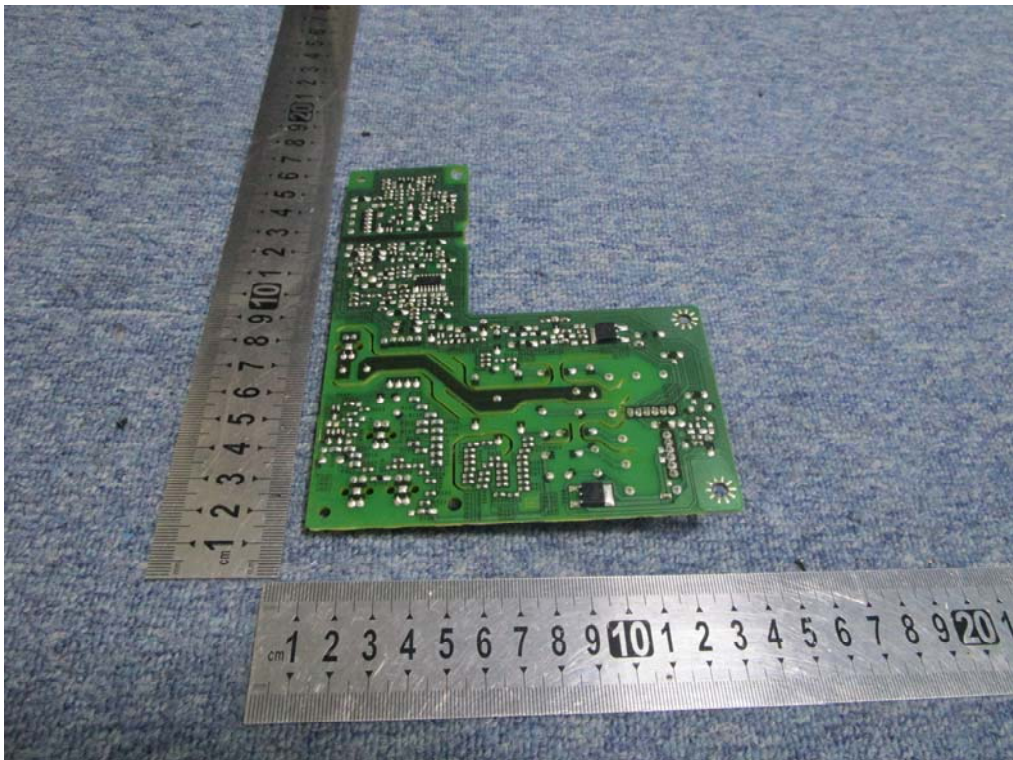
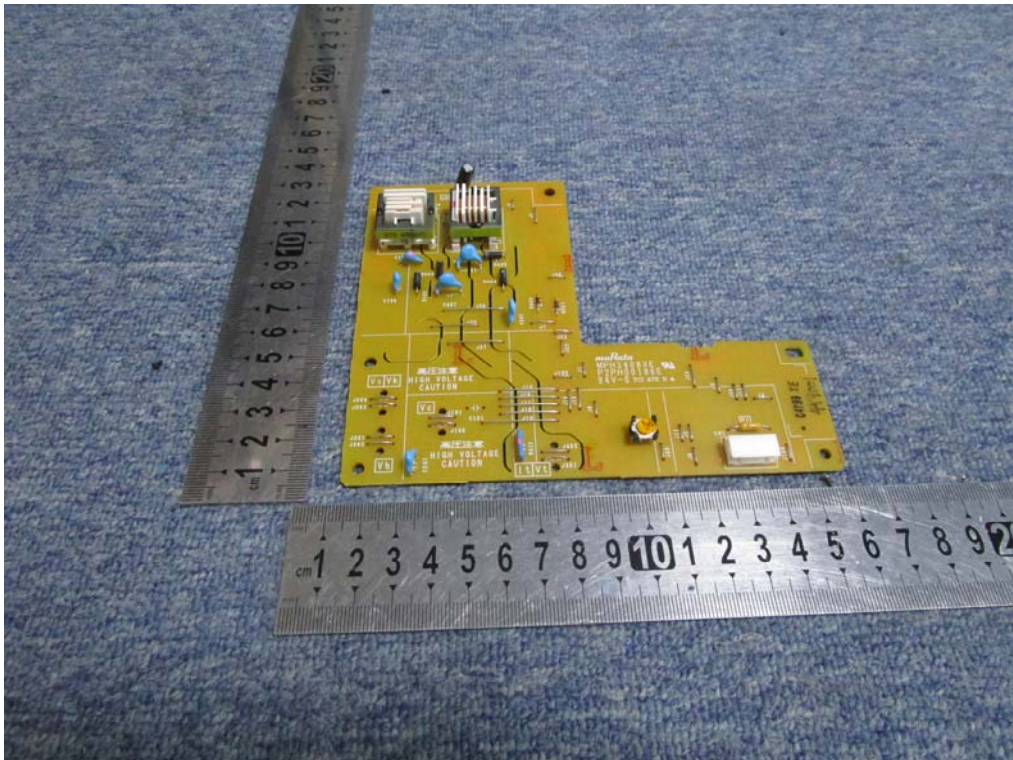

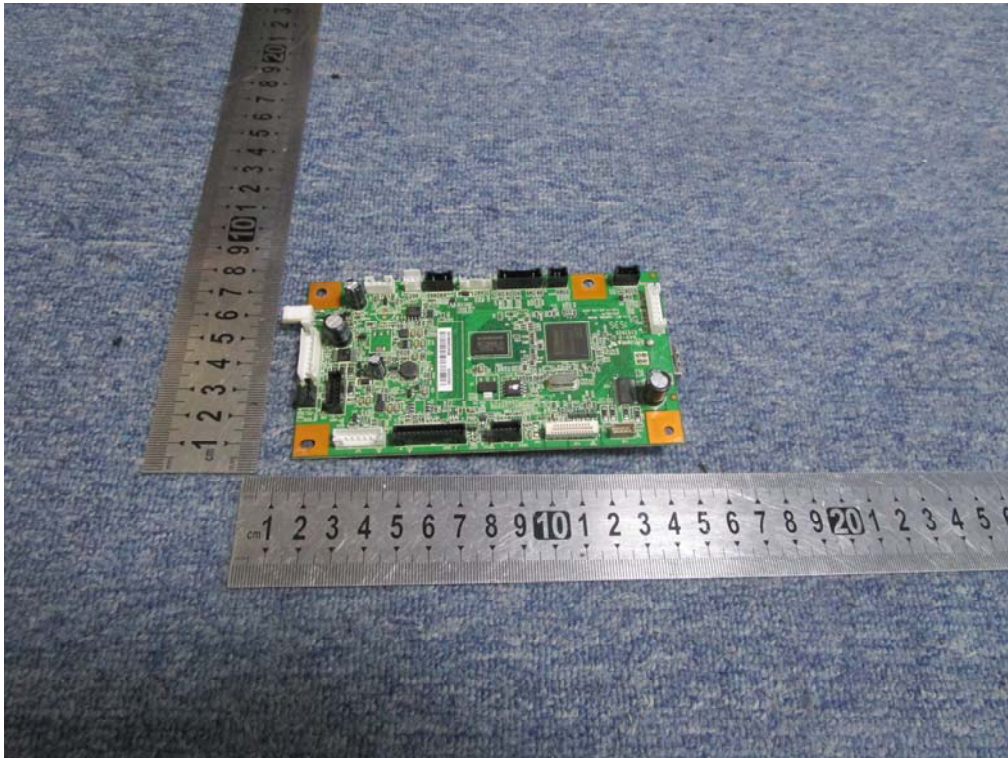

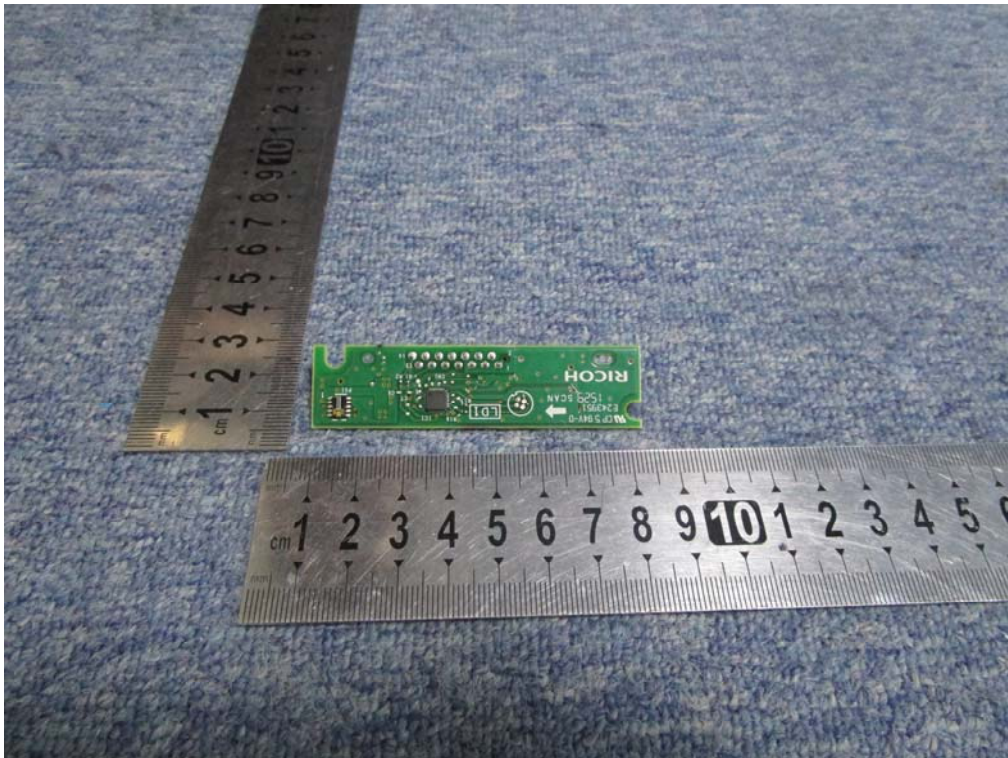
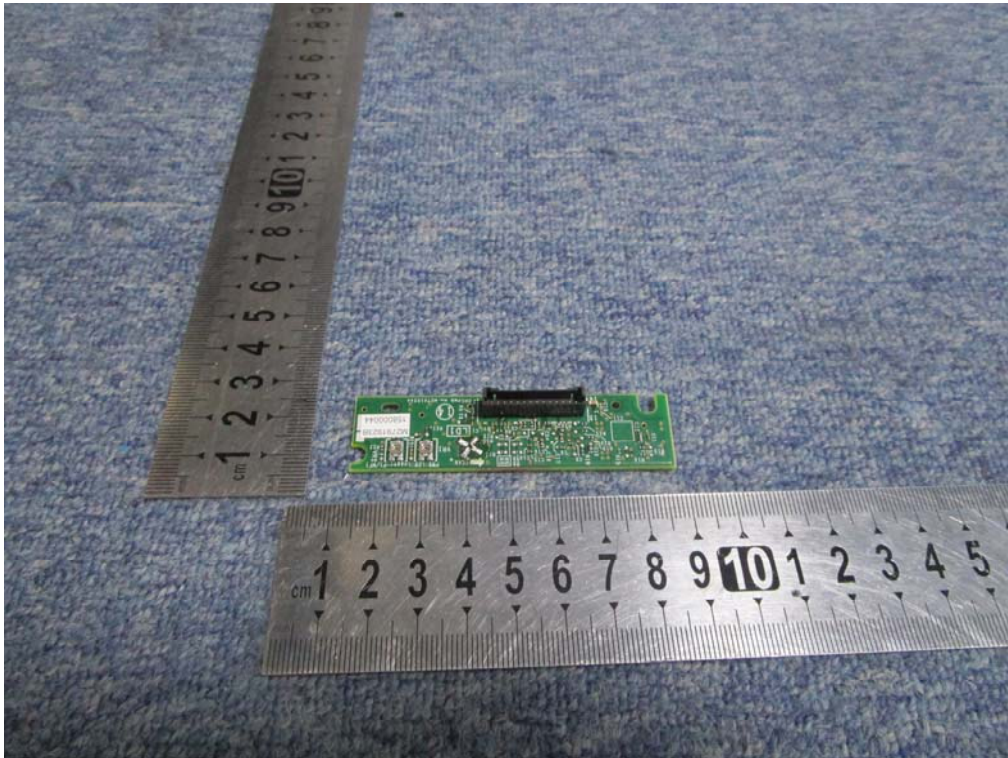



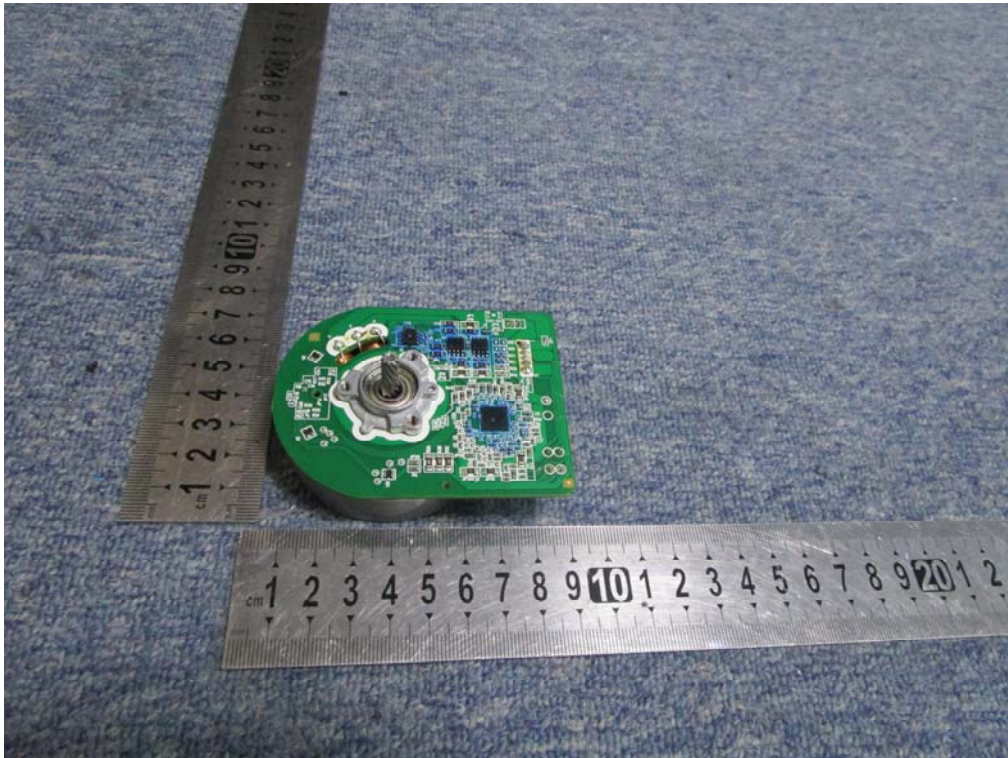

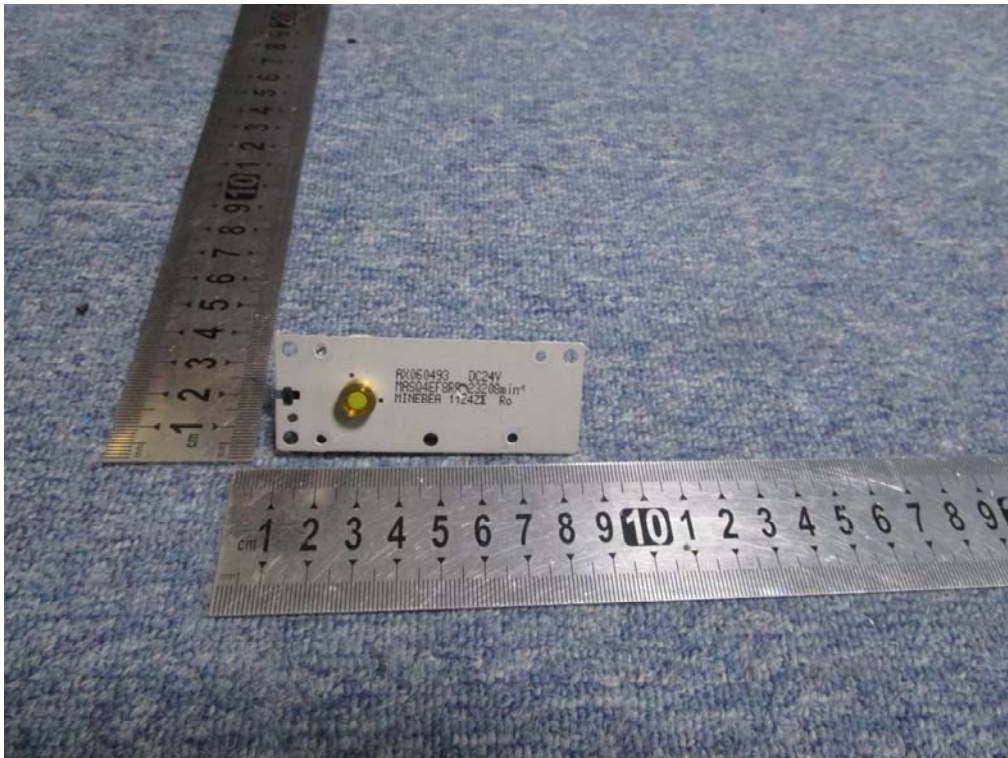
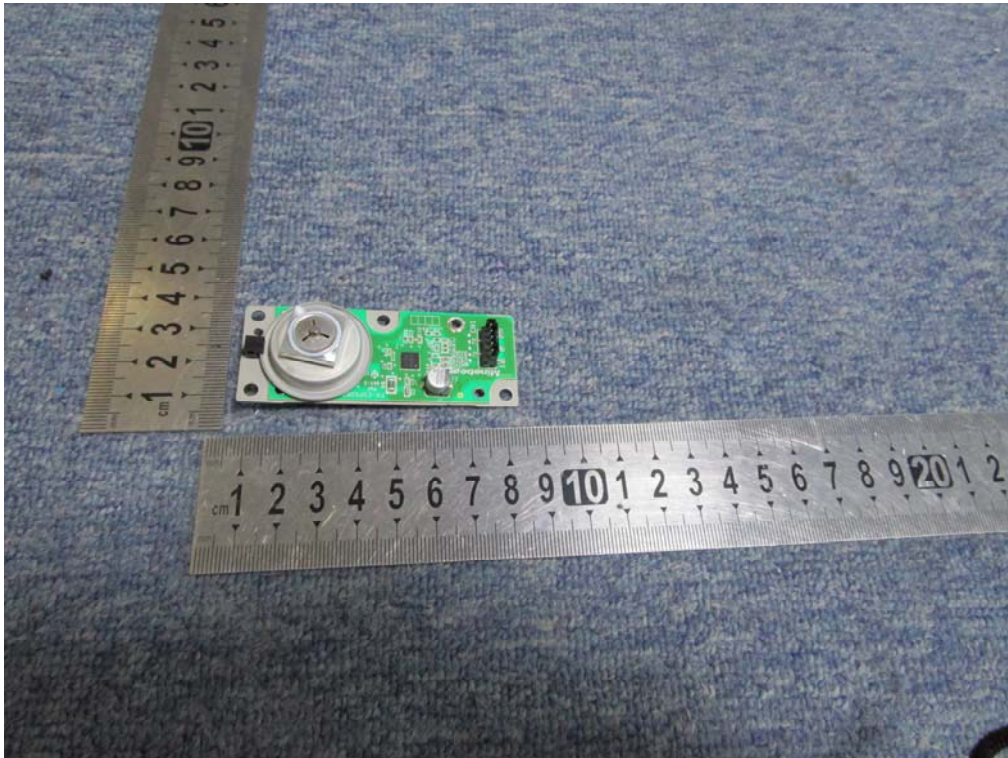

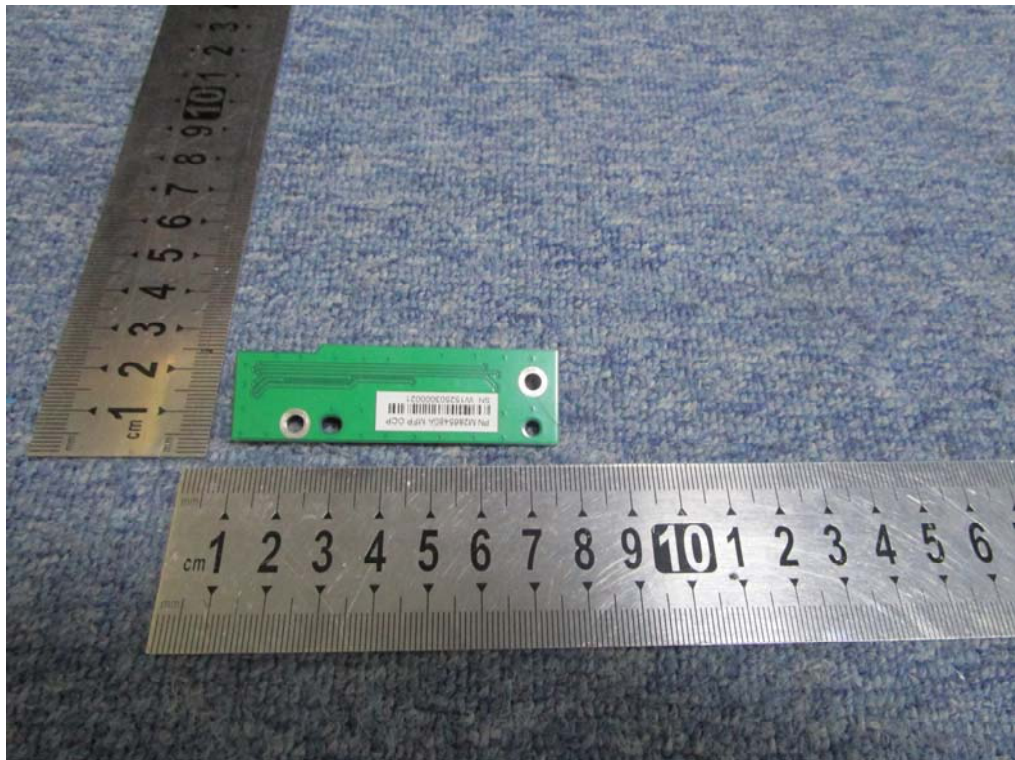
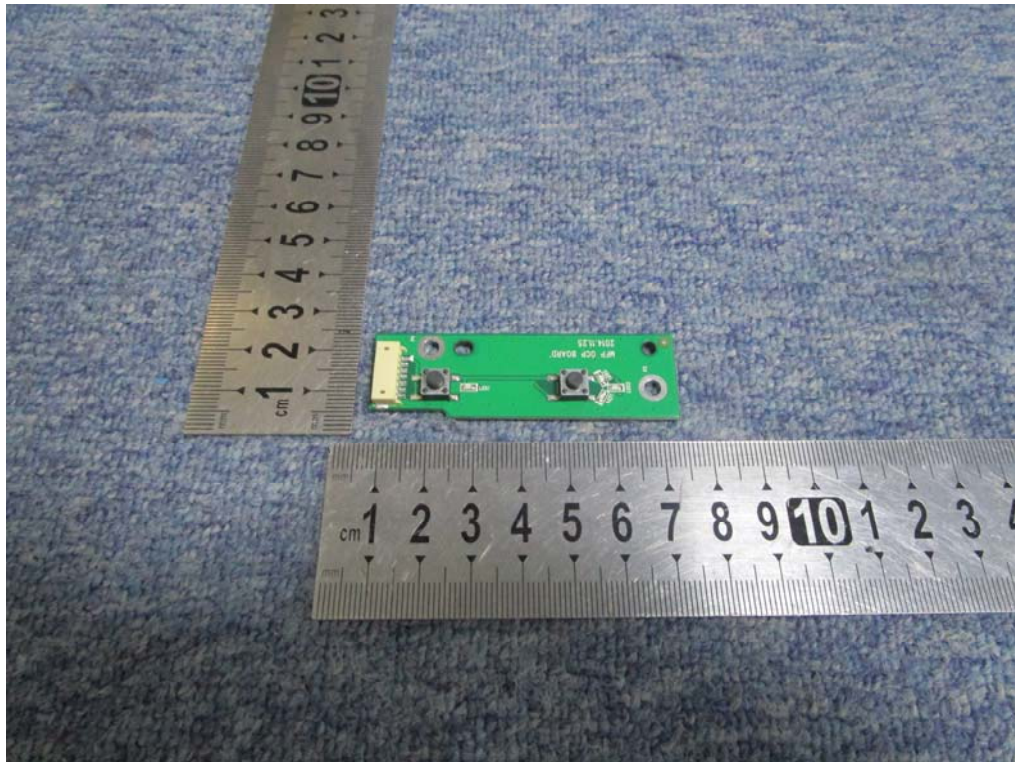

Appendix II: Photographs of EMC Test Configuration

1. Conducted Disturbance at Mains Terminals



2. Radiated Field Strength Measurement

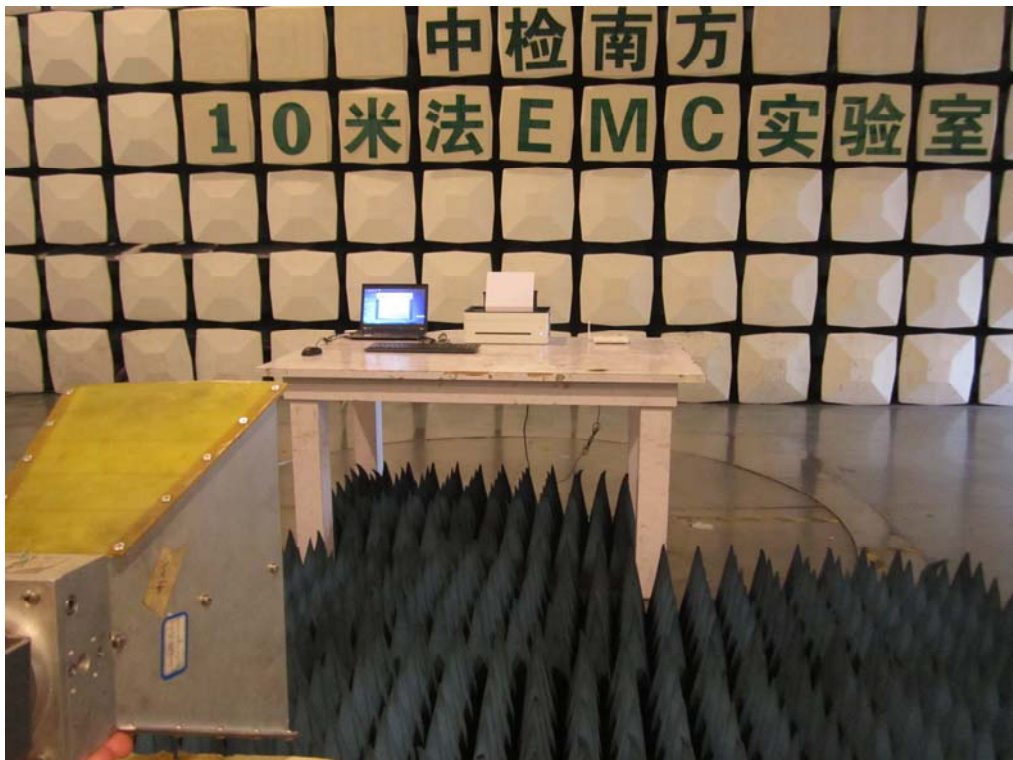

End of Report