

TABLE OF CONTENTS LIST

APPLICANT: COBRA ELECTRONICS CORPORATION

FCC ID: BBOPR135

TEST REPORT:

PAGE 1.....COVER SHEET - GENERAL INFORMATION & TECHNICAL DESCR.
PAGE 2.....TECHNICAL DESCRIPTION CONTINUED
PAGE 3.....RF POWER OUTPUT
PAGE 4.....MODULATION CHARACTERISTICS
PAGE 5.....AUDIO FREQUENCY RESPONSE GRAPH
PAGE 6.....MODULATION LIMITING GRAPH - 300Hz
PAGE 7.....MODULATION LIMITING GRAPH - 1000Hz
PAGE 8.....MODULATION LIMITING GRAPH - 2500Hz
PAGE 9.....AUDIO LOW PASS FILTER GRAPH
PAGE 10.....OCCUPIED BANDWIDTH
PAGE 11.....OCCUPIED BANDWIDTH PLOT
PAGE 12.....OCCUPIED BANDWIDTH PLOT - CW
PAGE 13.....SPURIOUS EMISSIONS AT ANTENNA TERMINALS
PAGE 14.....UNWANTED RADIATION
PAGE 15.....METHOD OF MEASURING RADIATED SPURIOUS EMISSIONS
PAGE 16.....FREQUENCY STABILITY
PAGE 17-19..LIST OF TEST EQUIPMENT

EXHIBITS CONTAINING:

EXHIBIT 1.....FCC ID LABEL SAMPLE & SKETCH OF LOCATION
EXHIBIT 2.....EXTERNAL PHOTOGRAPHS
EXHIBIT 3.....INTERNAL PHOTOGRAPHS
EXHIBIT 4.....BLOCK DIAGRAM
EXHIBIT 5.....SCHEMATICS
EXHIBIT 6.....USER'S MANUAL
EXHIBIT 7.....CIRCUIT DESCRIPTION
EXHIBIT 8.....TUNING PROCEDURE
EXHIBIT 9.....TEST SET UP PHOTO

APPLICANT: COBRA ELECTRONICS CORPORATION

FCC ID: BBOPR135

REPORT #: C:\COBRA\1004AUT2\1004AUT2TestReport.doc

TABLE OF CONTENTS

GENERAL INFORMATION REQUIRED
FOR CERTIFICATION

2.1033(c)(1)(2) COBRA ELECTRONICS CORPORATION will manufacture the
FCCID: BBOPR135 GMRS/FRS COMBINATION
TRANSCEIVER in quantity, for use under FCC RULES
PART 95.

COBRA ELECTRONICS CORPORATION
6500 WEST CORTLAND STREET
CHICAGO IL 60707

2.1033 (c) TECHNICAL DESCRIPTION

2.1033(c)(3) Instruction book. A draft copy of the instruction
manual is included as EXHIBIT 6.

2.1033(c) (4) Type of Emission: 10K0F3E
95.631

Bn = 2M + 2DK
M = 3000
D = 1.75K
Bn = 2(3000)+2(2000) = 10K

GMRS Authorized Bandwidth 20.0 kHz

2.1033(c)(5) GMRS Frequency Range: 1. 462.5500 7. 462.6375
95.621 2. 462.5625 8. 462.6500
3. 462.5750 9. 462.6625
4. 462.6000 10. 462.7000
5. 462.6125 11. 462.7125
6. 462.6250 12. 462.7250

2.1033(c)(5) FRS Frequency Range: 1. 462.5625 8. 467.5625
95.627 2. 462.5875 9. 467.5875
3. 462.6125 10. 467.6125
4. 462.6375 11. 467.6375
5. 462.6625 12. 467.6625
6. 462.6875 13. 467.6875
7. 462.7125 14. 467.7125 MHz

FRS Authorized Bandwidth 12.5 kHz

2.1033(c)(6)(7) Power Output shall not exceed 0.50 Watts effective
95.639 radiated power. There can be no provisions for
95.649 increasing the power or varying the power.

2.1033(c)(8) DC Voltages and Current into Final Amplifier:
FINAL AMPLIFIER ONLY

FOR LOW POWER SETTING INPUT POWER: (6.0V)(.210A) = 1.26 Watts
FOR HIGH POWER SETTING INPUT POWER: (6.0V)(.600A) = 3.60 Watts

2.1033(c)(9) Tune-up procedure. The tune-up procedure is included as EXHIBIT # 8.

2.1033(c)(10) Complete Circuit Diagrams: The circuit diagram is included as EXHIBIT 5 of this report. The block diagrams are included as EXHIBIT 4 of this report.

2.1033(c)(11) A photograph or a drawing of the equipment identification label is included as exhibit No. 1.

2.1033(c)(12) Photographs(8"X10") of the equipment of sufficient clarity to reveal equipment construction and layout, including meters, labels for controls, including any view under shields. See exhibits 2-3.

2.1033(c)(13) Digital modulation is not allowed.

2.1033(c)(14) The data required by 2.1046 through 2.1057 is submitted below.

2.1046(a) RF power is measured by the substitution method as outlined in TIA/EIA - 603. With a nominal battery voltage of 6.0 V, and the transmitter properly adjusted the RF output measures:

OUTPUT POWER: HIGH .5 Watts ERP
FRS: .5 Watts ERP

2.1046(a) RF power output. The test procedure used was TIA/EIA-603 S2

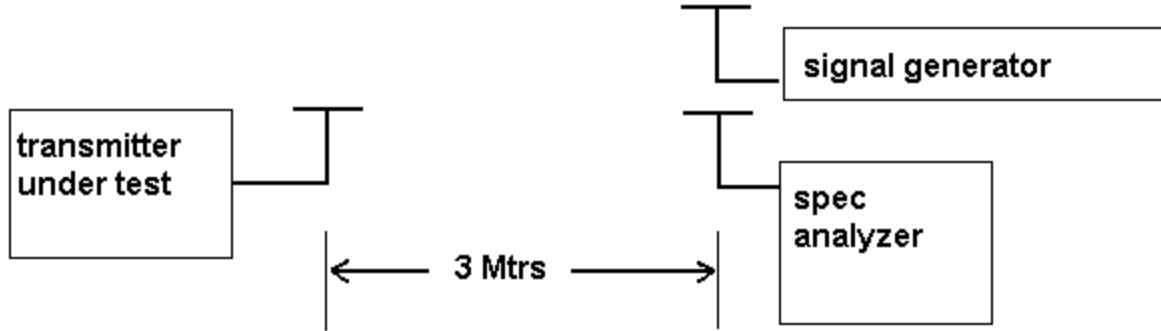

2.1047(a)(b) Modulation characteristics:

AUDIO FREQUENCY RESPONSE

The audio frequency response was measured in accordance with TIA/EIA Specification 603. The audio frequency response curve is shown on the next page. The audio signal was fed into a dummy microphone circuit and into the microphone connector. The input required to produce 30 percent modulation level was measured. See Page 5 of report.

2.1047(b) Audio input versus modulation

The audio input level needed for a particular percentage of modulation was measured in accordance with TIA/EIA Specification 603. The audio input curves versus modulation are on the following pages. Curves are provided for audio input frequencies of 300, 1000, and 2500 Hz. See Pages 6,7 & 8 of report.

95.637

Post Limiter Filter Each GMRS transmitter, except a mobile station transmitter with a power of 2.5Watts or less, must be equipped with an audio low pass filter. At any frequency between 3 & 20 kHz the filter must have an attenuation of $60\log(f/3)$ greater than the attenuation at 1 kHz. See Page 9 of report.

AUDIO FREQUENCY RESPONSE GRAPH

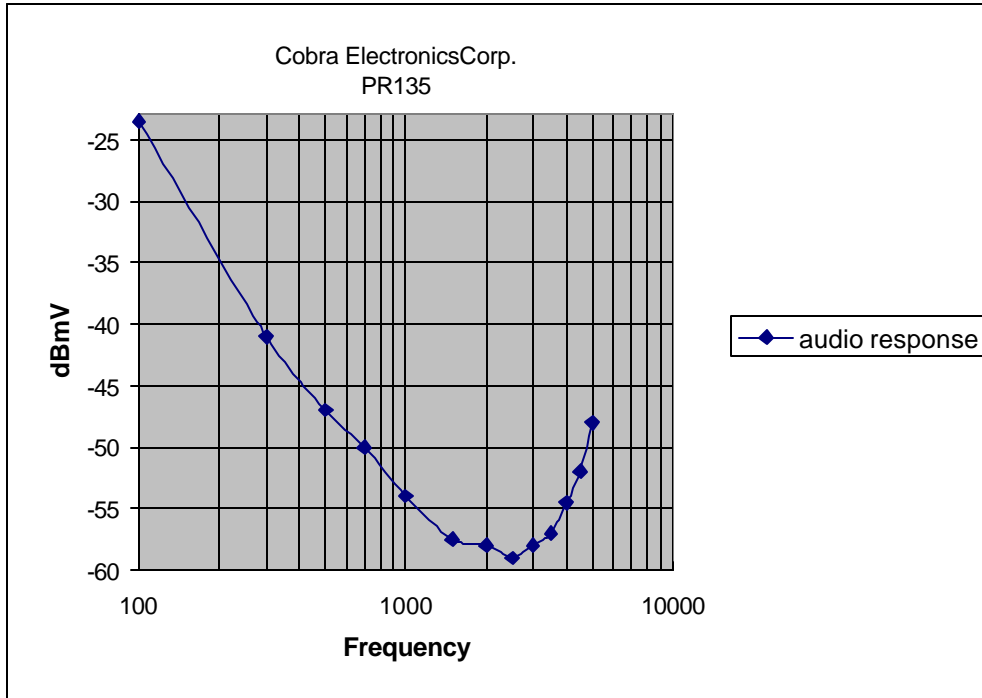

MODULATION LIMITING GRAPH - 300 Hz

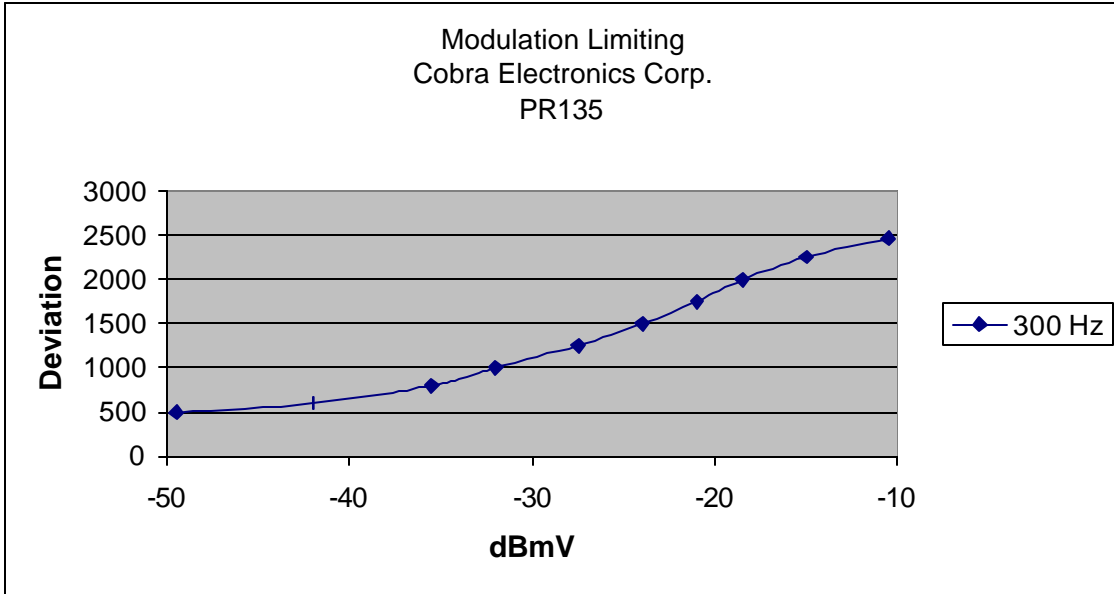

MODULATION LIMITING GRAPH - 1000 Hz

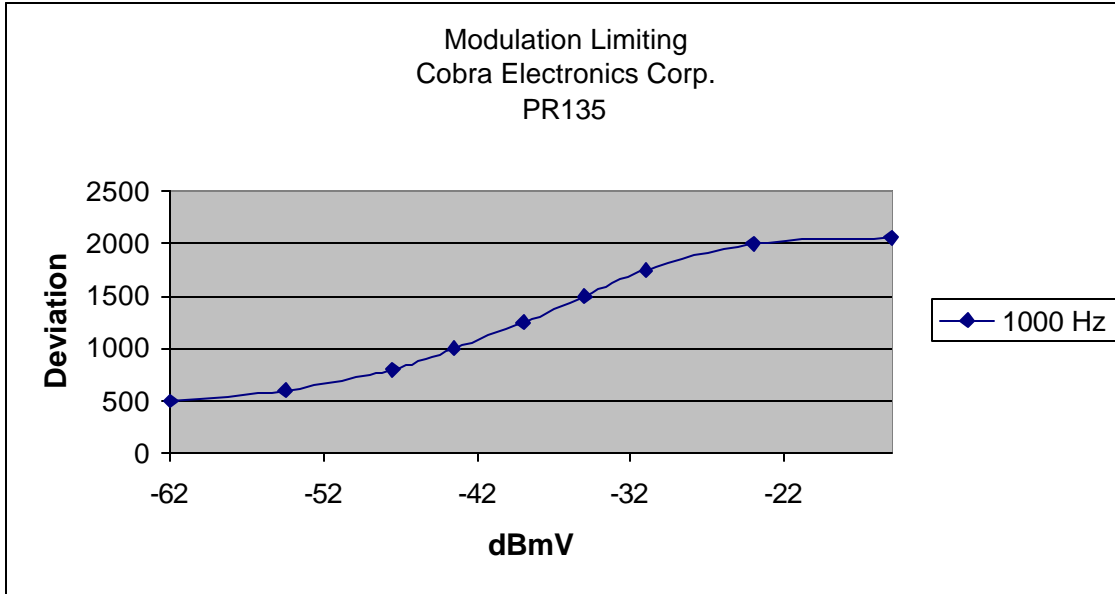

MODULATION LIMITING GRAPH - 2500 Hz

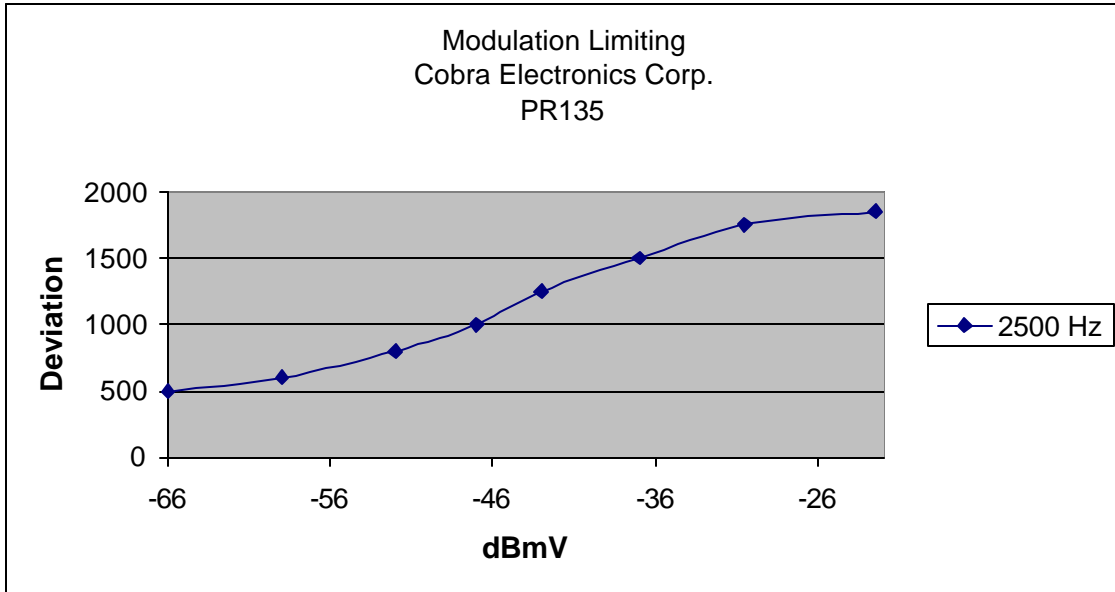

AUDIO LOW PASS FILTER GRAPH

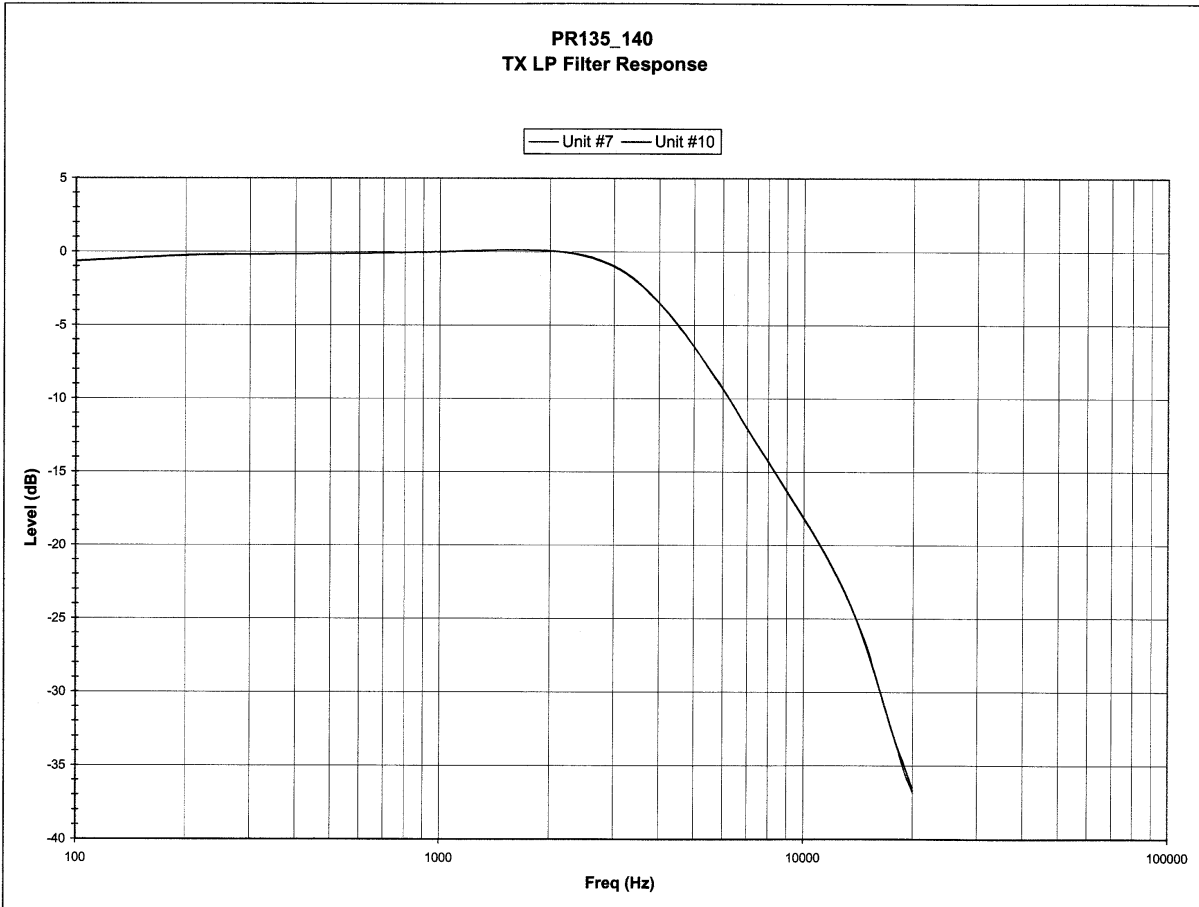

2.1049 Occupied bandwidth:
95.635(b)(1)(3)(7)

At least 25dB on any frequency removed from the center of the authorized bandwidth by more than 50% up to and including 100% of the authorized bandwidth. At least 35 dB on any frequency removed from the center of the authorized BW by more than 100% up to and including 250% of the authorized BW. At least $43 + \log_{10}(TP)$ dB on any frequency removed from the center of the authorized bandwidth by more than 250%. See plots on pages 11 and 12.

Occupied BW Test Equipment Setup

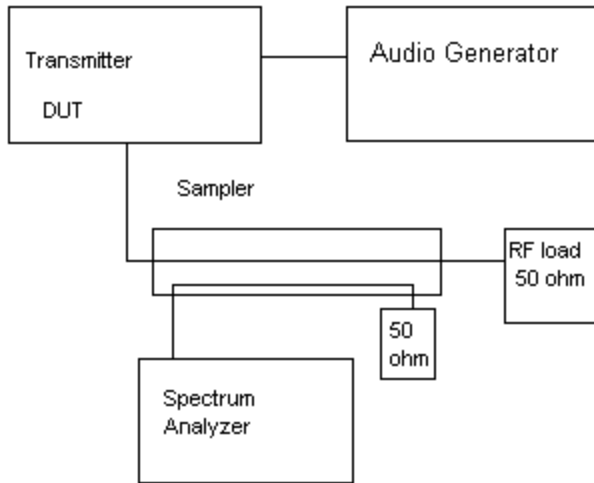

OCCUPIED BANDWIDTH PLOT

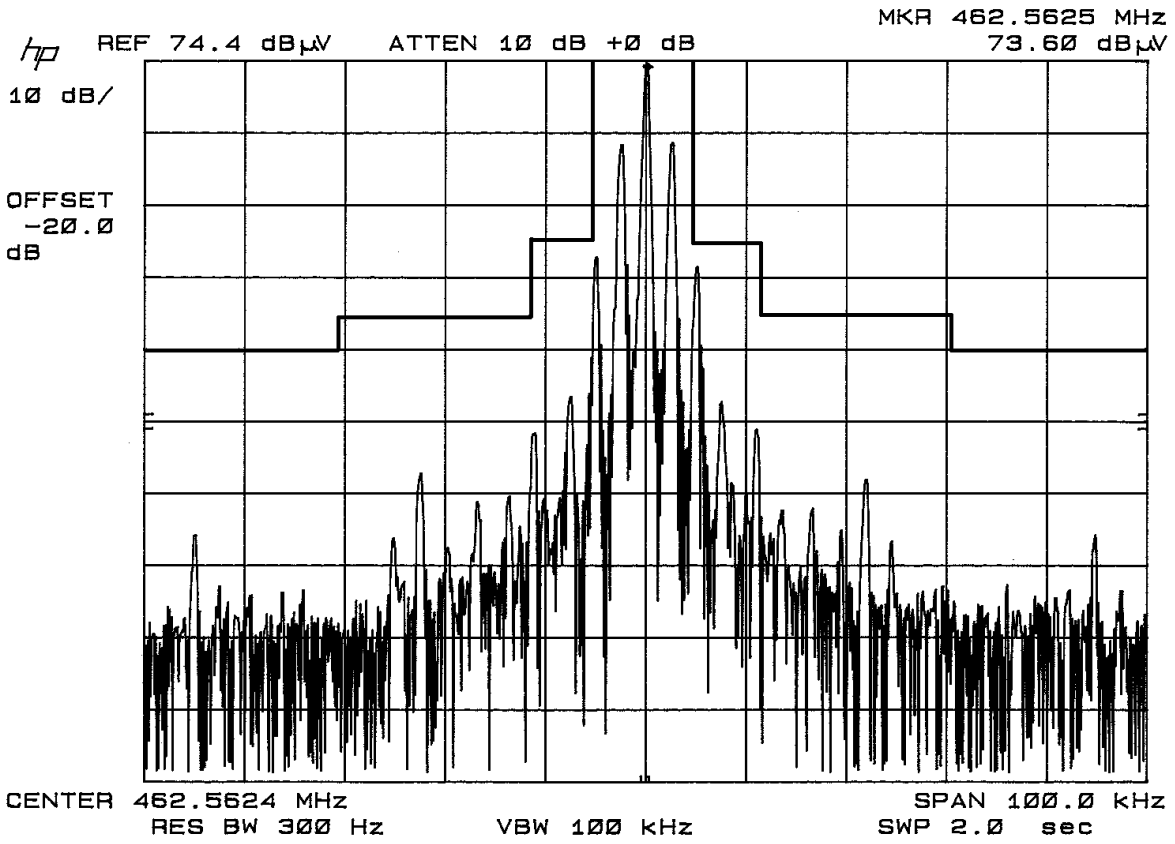

OCCUPIED BANDWIDTH CW PLOT

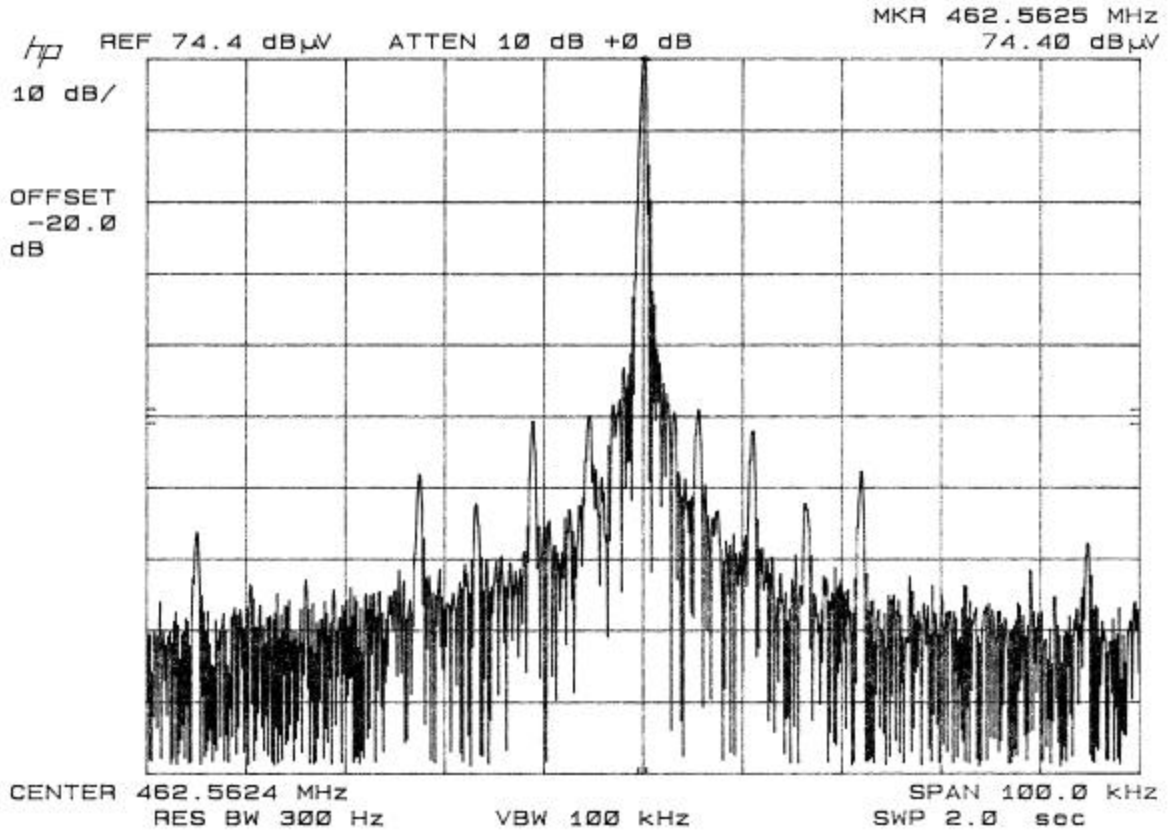

2.1051

Spurious emissions at antenna terminals(conducted):
The following data shows the level of conducted spurious responses at the antenna terminal. The test procedure used was TIA/EIA 603 S2.2.13 with the exception that the emissions were recorded in dBc. The spectrum was scanned from 0.4 to at least the 10th harmonic of the fundamental.

Spurious Emissions at
Antenna Terminals

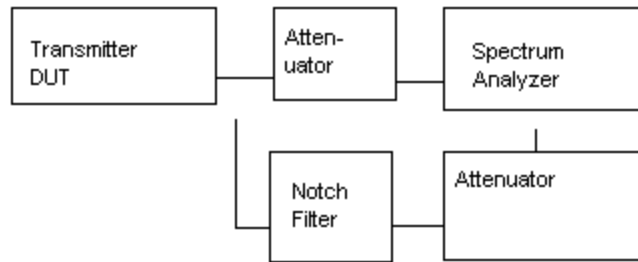

Method of Measuring Conducted Spurious Emissions

2.1051 Spurious emissions at the Antenna Terminals

NAME OF TEST: SPURIOUS EMISSIONS AT ANTENNA TERMINALS

2.1051 Not Applicable, no antenna terminal allowed.

2.1053
95.635(b)(7)

UNWANTED RADIATION:

The tabulated Data shows the results of the radiated field strength emissions test. The spectrum was scanned from 30 to at least the 10th harmonic of the fundamental. This test was conducted per ANSI C63.4-1992.

REQUIREMENTS: GMRS: $43 + 10\log(.5) = 40$ dB
FRS: $43 + 10\log(.5) = 40$ dB

TEST DATA (CHANNEL 22)(GMRS):

Emission Frequency MHz	ATTN dBc	dBm
462.70	0.00	16.3
925.50	54.3	-38
1,388.30	51.3	-35
1,851.00	61.3	-45
2,313.70	55.3	-39
2,776.50	61.3	-45
3,239.20	59.3	-43
3,702.00	46.3	-30
4,164.70	45.3	-29
4,627.50	76.82	-37

TEST DATA (CHANNEL 8)(FRS):

Emission Frequency MHz	ATTN dBc	dBm
467.50	0.00	16.3
935.10	55.3	-39
1,402.60	56.3	-40
1,870.20	58.3	-42
2,337.80	59.3	-43
2,805.40	65.3	-49
3,272.90	62.3	-46
3,740.50	54.3	-38
4,208.10	49.3	-33
4,675.60	62.3	-46

METHOD OF MEASUREMENT: The tabulated data shows the results of the radiated field strength emissions test. The spectrum was scanned from 30 to at least the tenth harmonic of the fundamental. This test was conducted per TIA/EIA STANDARD 603 using the substitution method. Measurements were made at the open field test site of TIMCO ENGINEERING, INC. located at 849 NW State Road 45, Newberry, FL 32669.

APPLICANT : COBRA ELECTRONICS CORPORATION

FCC ID : BBOPR135

Method of Measuring Radiated Spurious Emissions

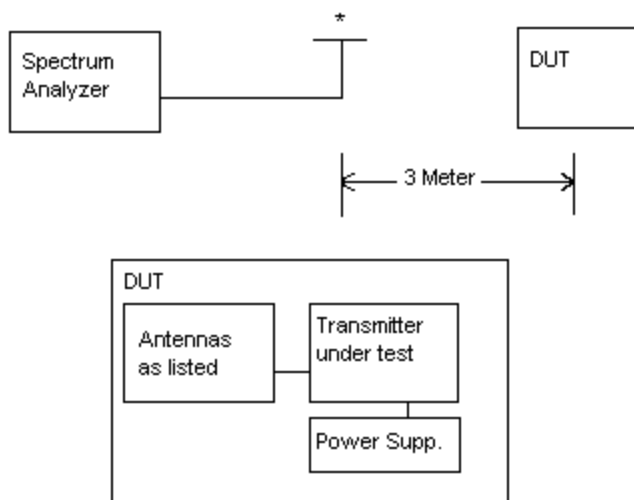

Equipment placed 80 cm above ground on a rotatable platform.

* Appropriate antenna raised from 1 to 4 M.

2.1055
95.621(b)

Frequency stability:

Temperature and voltage tests were performed to verify that the frequency remains within the 0.0005%, 5 ppm specification limit. The test was conducted as follows: The transmitter was placed in the temperature chamber at 25 degrees C and allowed to stabilize for one hour. The transmitter was keyed ON for one minute during which four frequency readings were recorded at 15 second intervals. The worse case number was taken for temperature plotting. The assigned channel frequency was considered to be the reference frequency. The temperature was then reduced to -30 degrees C after which the transmitter was again allowed to stabilize for one hour. The transmitter was keyed ON for one minute, and again frequency readings were noted at 15 second intervals. The worst case number was recorded for temperature plotting. This procedure was repeated in 10 degree increments up to + 50 degrees C.

Readings were also taken at the battery voltage of 6.0 VDC.

MEASUREMENT DATA:

Assigned Frequency (Ref. Frequency): 462.725 202

TEMPERATURE °C	FREQUENCY MHz	PPM
REFERENCE	462.725 202	00.00
-30	462.724 72	-1.04
-20	462.725 256	0.12
-10	462.725 709	1.10
0	462.726 033	1.80
+10	462.726 082	1.90
+20	462.725 79	1.27
+30	462.725 33	0.28
+40	462.724 88	-0.70
+50	462.724 695	-1.10
BATT. End-Point 5.1V/dc	462.725 19	-0.03

RESULTS OF MEASUREMENTS: The maximum frequency variation over the temperature range was -1.10 to + 1.90ppm. The maximum frequency variation with voltage was -0.03 ppm.

Note: This EUT meets the frequency stability requirement for a FRS: +/- 2.5ppm over temp range of -20 degrees C to +50 degrees C. It also meets the GMRS frequency stability requirements: +/- 5ppm over the temp range -30 degrees C to +50 degrees C.

EMC Equipment List

	DEVICE	MFGR	MODEL	SERNO	CAL/CHAR DATE	DUE DATE or STATUS
X	3-Meter OATS	TEI	N/A	N/A	Listed 12/22/99	12/22/02
	3/10-Meter OATS	TEI	N/A	N/A	Listed 3/26/01	3/26/04
	Receiver, Beige Tower Spectrum Analyzer (Tan)	HP	8566B Opt 462	3138A07786 3144A20661	CAL 8/31/01	8/31/03
	RF Preselector (Tan)	HP	85685A	3221A01400	CAL 8/31/01	8/31/03
	Quasi-Peak Adapter (Tan)	HP	85650A	3303A01690	CAL 8/31/01	8/31/03
X	Receiver, Blue Tower Spectrum Analyzer (Blue)	HP	8568B	2928A04729 2848A18049	CHAR 10/22/01	10/22/03
X	RF Preselector (Blue)	HP	85685A	2926A00983	CHAR 10/22/01	10/22/03
X	Quasi-Peak Adapter (Blue)	HP	85650A	2811A01279	CHAR 10/22/01	10/22/03
X	Biconnical Antenna	Electro-Metrics	BIA-25	1171	CAL 4/26/01	4/26/03
	Biconnical Antenna	Eaton	94455-1	1096	CAL 10/1/01	10/1/03
	Biconnical Antenna	Eaton	94455-1	1057	CHAR 3/15/00	3/15/02
	BiconiLog Antenna	EMCO	3143	9409-1043		
X	Log-Periodic Antenna	Electro-Metrics	LPA-25	1122	CAL 10/2/01	10/2/03
	Log-Periodic Antenna	Electro-Metrics	EM-6950	632	CHAR 10/15/01	10/15/03
	Log-Periodic Antenna	Electro-Metrics	LPA-30	409	CHAR 10/16/01	10/16/03
	Dipole Antenna Kit	Electro-Metrics	TDA-30/1-4	152	CAL 3/21/01	3/21/04
	Dipole Antenna Kit	Electro-Metrics	TDA-30/1-4	153	CHAR 11/24/00	11/24/03
	Double-Ridged Horn Antenna	Electro-Metrics	RGA-180	2319	CAL 12/19/01	12/19/03
	Horn Antenna	Electro-Metrics	EM-6961	6246	CAL 3/21/01	3/21/03

	DEVICE	MFGR	MODEL	SERNO	CAL/CHAR DATE	DUE DATE or STATUS
	Horn Antenna	ATM	19-443-6R	None	No Cal Required	
	Passive Loop Antenna	EMC Test Systems	EMCO 6512	9706-1211	CHAR 7/10/01	7/10/03
	Line Impedance Stabilization . . .	Electro-Metrics	ANS-25/2	2604	CAL 10/9/01	10/9/03
	Line Impedance Stabilization . . .	Electro-Metrics	EM-7820	2682	CAL 3/16/01	3/16/03
	Termaline Wattmeter	Bird Electronic Corporation	611	16405	CAL 5/25/99	5/25/01
	Termaline Wattmeter	Bird Electronic Corporation	6104	1926	CAL 12/12/01	12/12/03
	Oscilloscope	Tektronix	2230	300572	CHAR 2/1/01	2/1/03
X	Temperature Chamber	Tenney Engineering	TTRC	11717-7	CHAR 1/22/02	1/22/04
X	AC Voltmeter	HP	400FL	2213A14499	CAL 10/9/01	10/9/03
	AC Voltmeter	HP	400FL	2213A14261	CHAR 10/15/01	10/15/03
	AC Voltmeter	HP	400FL	2213A14728	CHAR 10/15/01	10/15/03
X	Digital Multimeter	Fluke	77	35053830	CHAR 1/8/02	1/8/04
	Digital Multimeter	Fluke	77	43850817	CHAR 1/8/02	1/8/04
	Digital Multimeter	HP	E2377A	2927J05849	CHAR 1/8/02	1/8/04
	Multimeter	Fluke	FLUKE-77-3	79510405	CAL 9/26/01	9/26/03
	Peak Power Meter	HP	8900C	2131A00545	CHAR 1/26/01	1/26/03
	Digital Thermometer	Fluke	2166A	42032	CAL 1/16/02	1/16/04
	Thermometer	Traulsen	SK-128		CHAR 1/22/02	1/22/04
X	Temp/Humidity gauge	EXTech	44577F	E000901	CHAR 1/22/02	1/22/04
	Frequency Counter	HP	5352B	2632A00165	CAL 11/28/01	11/28/03
	Power Sensor	Agilent Technologies	84811A	2551A02705	CAL 1/26/01	1/26/03

	DEVICE	MFGR	MODEL	SERNO	CAL/CHAR DATE	DUE DATE or STATUS
	Service Monitor	IFR	FM/AM 500A	5182	CAL 11/22/00	11/22/02
	Comm. Serv. Monitor	IFR	FM/AM 1200S	6593	CAL 5/12/02	5/12/04
	Signal Generator	HP	8640B	2308A21464	CAL 11/15/01	11/15/03
	Modulation Analyzer	HP	8901A	3435A06868	CAL 9/5/01	9/5/03
	Near Field Probe	HP	HP11940A	2650A02748	CHAR 2/1/01	2/1/03
	BandReject Filter	Lorch Microwave	5BR4-2400/60-N	Z1	CHAR 3/2/01	3/2/03
	BandReject Filter	Lorch Microwave	6BR6-2442/300-N	Z1	CHAR 3/2/01	3/2/03
	BandReject Filter	Lorch Microwave	5BR4-10525/900-S	Z1	CHAR 3/2/01	3/2/03
	High Pas Filter	Microlab	HA-10N		CHAR 10/4/01	10/4/03
	Audio Oscillator	HP	653A	832-00260	CHAR 3/1/01	3/1/03
	Frequency Counter	HP	5382A	1620A03535	CHAR 3/2/01	3/2/03
	Frequency Counter	HP	5385A	3242A07460	CHAR 12/11/01	12/11/03
	Preamplifier	HP	8449B-H02	3008A00372	CHAR 3/4/01	3/4/03
	Amplifier	HP	11975A	2738A01969	CHAR 3/1/01	3/1/03
	Egg Timer	Unk			CHAR 8/31/01	8/31/03
	Measuring Tape, 20M	Kraftixx	0631-20		CHAR 2/1/02	2/1/04
	Measuring Tape, 7.5M	Kraftixx	7.5M PROFI		2/1/02	2/1/04
	Coaxial Cable #51	Insulated Wire Inc.	NPS 2251-2880	Timco #51	CHAR 1/23/02	1/23/04
	Coaxial Cable #64	Semflex Inc.	60637	Timco #64	CHAR 1/24/02	1/24/04
	Coaxial Cable #65	General Cable Co.	E9917 RG233/U	Timco #65	CHAR 1/23/02	1/23/04
	Coaxial Cable #106	Unknown	Unknown	Timco #106	CHAR 1/23/02	1/23/04