



849 NW STATE ROAD 45
NEWBERRY, FL 32669 USA
PH: 888.472.2424 OR 352.472.5500
FAX: 352.472.2030
EMAIL: INFO@TIMCOENGR.COM
[HTTP://WWW.TIMCOENGR.COM](http://WWW.TIMCOENGR.COM)

FCC PART 95 AND IC RSS-210 FRS/GMRS TRANSCEIVER TEST REPORT

APPLICANT	COBRA ELECTRONICS CORPORATION 6500 WEST CORTLAND STREET CHICAGO IL 60707
FCC ID	BBOLI6700
IC CERT #	906B-LI6700
MODEL NUMBERS	LI6690, LI6700, LI6725, LI6750, LI6775
PRODUCT DESCRIPTION	FRS/GMRS TRANSCEIVER
DATE SAMPLE RECEIVED	6/18/2007
DATE TESTED	7/16/2007
TESTED BY	RICHARD BLOCK
APPROVED BY	Richard Block
TIMCO REPORT NO.	2322AUT7TestReport.doc
TOTAL PAGES	18
TEST RESULTS	<input checked="" type="checkbox"/> PASS <input type="checkbox"/> FAIL

**THE ATTACHED REPORT SHALL NOT BE REPRODUCED EXCEPT IN FULL
WITHOUT THE WRITTEN APPROVAL OF TIMCO ENGINEERING, INC.**



Certificate # 0955-01



Certificate # 0955-01

TABLE OF CONTENTS

STATEMENT OF COMPLIANCE..... 3

GENERAL INFORMATION 4

TEST PROCEDURE 5

RF POWER OUTPUT 6

MODULATION CHARACTERISTICS..... 7

EMISSION DESIGNATOR AND FREQUENCIES 10

OCCUPIED BANDWIDTH..... 11

SPURIOUS EMISSIONS AT ANTENNA TERMINALS (CONDUCTED)..... 13

FIELD STRENGTH OF SPURIOUS EMISSIONS - TX 14

FIELD STRENGTH OF SPURIOUS EMISSIONS - RX..... 16

FREQUENCY STABILITY..... 17

TEST EQUIPMENT LIST..... 18

Applicant: COBRA ELECTRONICS CORPORATION
 FCC ID: BBOLI6700
 IC Cert #: 906B-LI6700
 Report: W:\C\COBRA\2322AUT7\2322AUT7TestReport.doc



Certificate # 0955-01

STATEMENT OF COMPLIANCE

This equipment has been tested in accordance with the standards identified in the referenced test report. To the best of my knowledge and belief, these tests were performed using the measurement procedures described in this report and demonstrate that the equipment complies with the appropriate standards. No modifications were made to the equipment during testing in order to demonstrate compliance with these standards.

I attest that the necessary measurements were made by me or under my supervision, at Timco Engineering, Inc. located at 849 N.W. State Road 45, Newberry, Florida 32669 USA.

Authorized by: Richard Block

Signature: <Richard Block>

Function: Engineer

Date: 7/23/2007

Applicant: COBRA ELECTRONICS CORPORATION
FCC ID: BBOLI6700
IC Cert #: 906B-LI6700
Report: W:\C\COBRA\2322AUT7\2322AUT7TestReport.doc



Certificate # 0955-01

GENERAL INFORMATION

DUT Specification

The test results relate only to the items tested.	
DUT Description	FRS/GMRS TRANSCEIVER
FCC ID	BBOLI6700
IC Cert #	906B-LI6700
Model Number	LI6690, LI6700, LI6725, LI6750, LI6775
Operating Frequency	462.5500-462.7250, 467.5625-467.7125
No. of Channels	22
Type of Emission	10K5F3E
Modulation	FM
DUT Power Source	<input type="checkbox"/> 110-120Vac/50- 60Hz
	<input type="checkbox"/> DC Power
	<input checked="" type="checkbox"/> Battery Operated Exclusively
Test Item	<input type="checkbox"/> Prototype
	<input checked="" type="checkbox"/> Pre-Production
	<input type="checkbox"/> Production
Type of Equipment	<input type="checkbox"/> Fixed
	<input type="checkbox"/> Mobile
	<input checked="" type="checkbox"/> Portable
Antenna	Fixed
Test Facility	Timco Engineering Inc. located at 849 NW State Road 45 Newberry, FL 32669 USA.
Modifications	None
Test Exercise	The DUT was placed in continuous transmit mode of operation
Applicable Standards	TIA 603 , FCC CFR 47 Part 2 and Part 95, IC RSS-210 and RSS-GEN

Applicant: COBRA ELECTRONICS CORPORATION
 FCC ID: BBOLI6700
 IC Cert #: 906B-LI6700
 Report: W:\C\COBRA\2322AUT7\2322AUT7TestReport.doc



Certificate # 0955-01

TEST PROCEDURE

Bandwidth 20 dB: The measurements were made with the spectrum analyzer's resolution bandwidth (RBW) = 1 MHz and the video bandwidth (VBW) = 3 MHz and the span set as shown on plot.

Power Output: RF power was conducted per TIA/EIA STANDARD 603 using the substitution method

Antenna Conducted Emissions: The RBW = 100 kHz, VBW = 300 kHz and the span set to 10.0 MHz and the spectrum was scanned from 30 MHz to the 10th Harmonic of the fundamental. Above 1 GHz the resolution bandwidth was 1 MHz and the VBW = 3 MHz and the span to 50 MHz.

Radiation Interference: The test procedure used was TIA 603 using an Agilent spectrum receiver with pre-selector. The bandwidth (RBW) of the spectrum TIA 603 receiver was 100 kHz up to 1 GHz and 1 MHz above 1 GHz with an appropriate sweep speed. The VBW above 1 GHz was 3 MHz. The analyzer was calibrated in dB above a microvolt at the output of the antenna. The ambient temperature of the DUT was 76°F with a humidity of 55%.

Applicant: COBRA ELECTRONICS CORPORATION
FCC ID: BBOLI6700
IC Cert #: 906B-LI6700
Report: W:\C\COBRA\2322AUT7\2322AUT7TestReport.doc



Certificate # 0955-01

RF POWER OUTPUT

Rule Part No.: Part 2.1046(a), Part 95, RSS-210

Test Requirements:

Method of Measurement: RF power is measured as ERP as the antenna is permanently attached. The substitution method was used. With a nominal battery voltage, and the transmitter properly adjusted the RF output measures:

Test Setup Diagram:

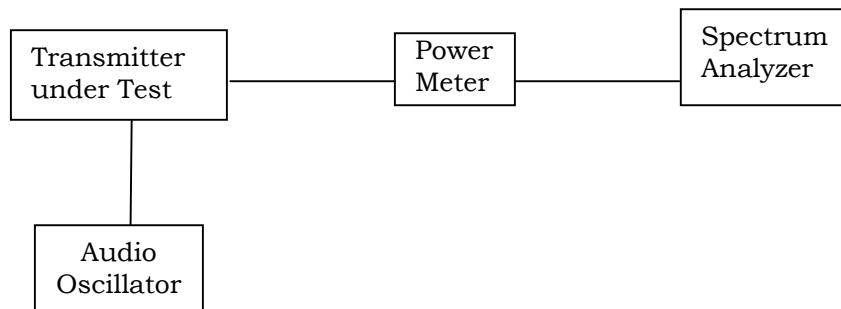

Test Data:

OUTPUT POWER: GMRS: 0.9 Watts
 FRS: 0.3 Watts

Part 2.1033 (C)(8) DC Input into the final amplifier

FOR LOW POWER SETTING INPUT POWER: $(7.4V)(.300A) = 2.22$ Watts
 FOR HIGH POWER SETTING INPUT POWER: $(7.4V)(.500A) = 3.70$ Watts



Certificate # 0955-01

MODULATION CHARACTERISTICS

Rule Part No.: Part 2.1047(a)(b)

Test Requirements:

Method of Measurement:

The audio frequency response was measured in accordance with TIA/EIA – 603. The audio frequency response curve is shown below. The audio signal was fed into a dummy microphone circuit and into the microphone connector. The input required to produce 30 percent modulation level was measured.

AUDIO FREQUENCY RESPONSE PLOT

AUDIO FREQUENCY RESPONSE PLOT

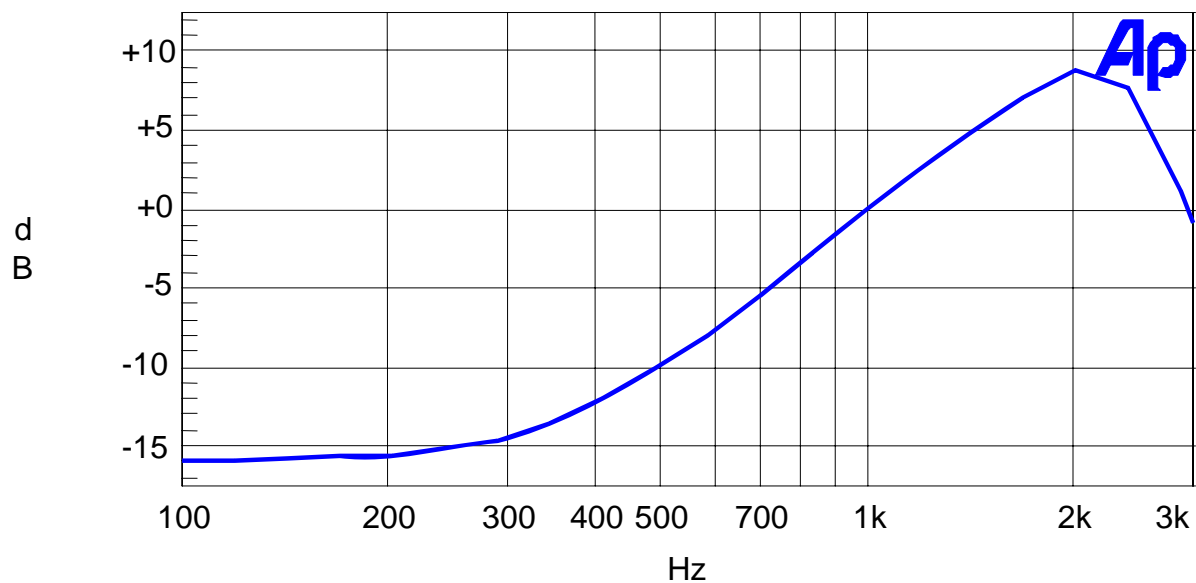

Applicant: COBRA ELECTRONICS CORPORATION

FCC ID: BBOLI6700

IC Cert #: 906B-LI6700

Report: W:\C\COBRA\2322AUT7\2322AUT7TestReport.doc



Certificate # 0955-01

Audio input versus modulation

The audio input level needed for a particular percentage of modulation was measured in accordance with TIA/EIA-603. Curves are provided for audio input frequencies of 300, 1000, and 2500 Hz. See the plot below..

MODULATION LIMITING PLOT
GREEN 2.5kHz -- BLUE 1.0kHz -- YELLOW 300Hz

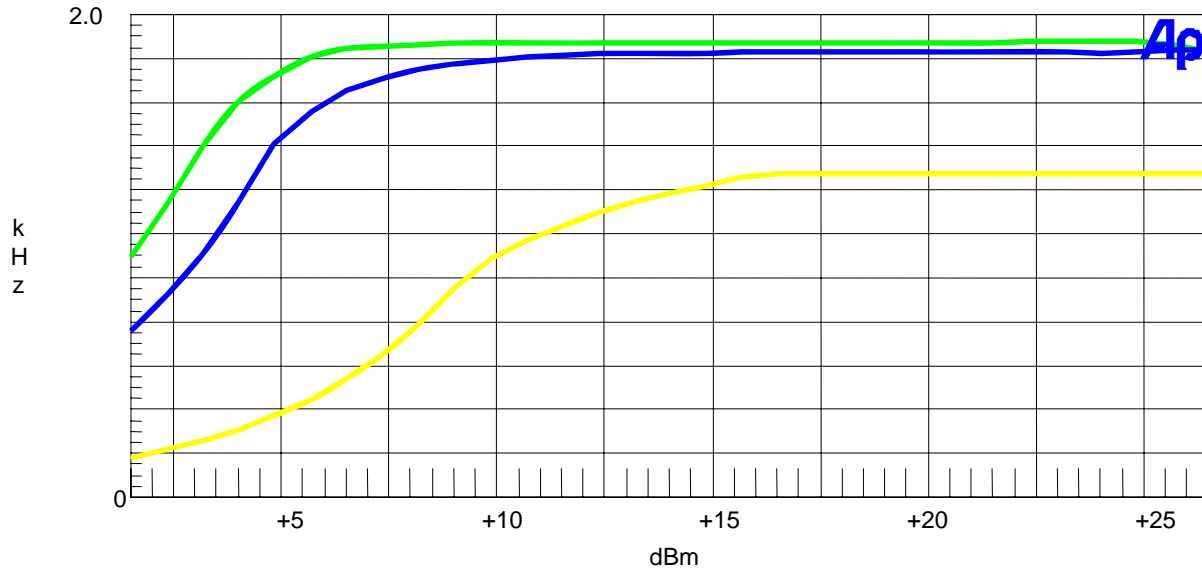

Applicant: COBRA ELECTRONICS CORPORATION
FCC ID: BBOLI6700
IC Cert #: 906B-LI6700
Report: W:\C\COBRA\2322AUT7\2322AUT7TestReport.doc



Certificate # 0955-01

Post Limiter Filter

Each GMRS transmitter, except a mobile station transmitter with a power of 2.5Watts or less, must be equipped with an audio low pass filter. At any frequency between 3 & 20 kHz the filter must have an attenuation of $60\log(f/3)$ greater than the attenuation at 1KHz. See below.

Audio Low Pass Filter

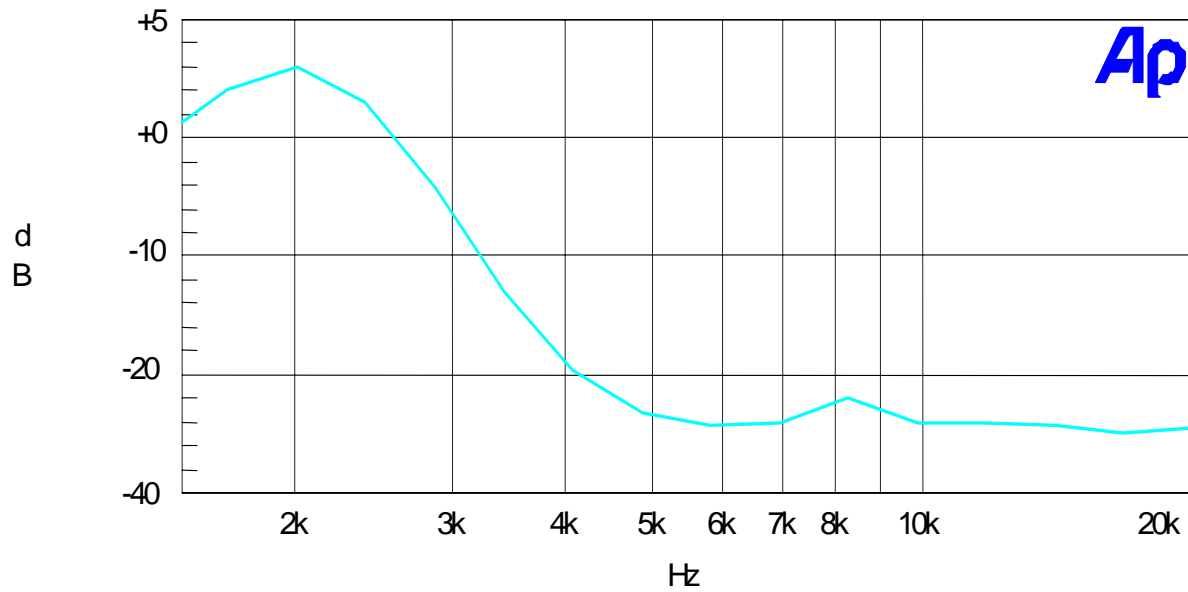



Certificate # 0955-01

EMISSION DESIGNATOR AND FREQUENCIES

2.1033(c) (4) Type of Emission: 10K5F3E
95.631

$$B_n = 2M + 2DK$$

$$M = 3000$$

$$D = 1.75K$$

$$B_n = 2(3000) + 2(2250) = 10.5K$$

GMRS Authorized Bandwidth 20.0 kHz

2.1033(c)(5) GMRS Frequency Range:
95.621

- | | |
|--------------|--------------|
| 1. 462.5500 | 13. 462.7000 |
| 2. 462.5625 | 14. 462.7125 |
| 3. 462.5750 | 15. 462.7250 |
| 4. 462.5875 | 16. 467.5500 |
| 5. 462.6000 | 17. 467.5750 |
| 6. 462.6125 | 18. 467.6000 |
| 7. 462.6250 | 19. 467.6250 |
| 8. 462.6375 | 20. 467.6500 |
| 9. 462.6500 | 21. 467.6750 |
| 10. 462.6625 | 22. 467.7000 |
| 11. 462.6750 | 23. 467.7250 |
| 12. 462.6875 | |

FRS Authorized Bandwidth 12.5KHz

2.1033(c)(5) FRS Frequency Range:
95.627

- | | |
|-------------|------------------|
| 1. 462.5625 | 8. 467.5625 |
| 2. 462.5875 | 9. 467.5875 |
| 3. 462.6125 | 10. 467.6125 |
| 4. 462.6375 | 11. 467.6375 |
| 5. 462.6625 | 12. 467.6625 |
| 6. 462.6875 | 13. 467.6875 |
| 7. 462.7125 | 14. 467.7125 MHz |



Certificate # 0955-01

OCCUPIED BANDWIDTH

Part 2.1049(c) EMISSION BANDWIDTH:
95.635(b)(1)(3)(7)

At least 25dB on any frequency removed from the center of the authorized bandwidth by more than 50% up to and including 100% of the authorized bandwidth. At least 35 dB on any frequency removed from the center of the authorized BW by more than 100% up to and including 250% of the authorized BW. At least $43 + \log_{10}(TP)$ dB on any frequency removed from the center of the authorized bandwidth by more than 250%. See the following plot.

Test procedure: TIA/EIA-603 para 2.2.11.

Test procedure diagram

OCCUPIED BANDWIDTH MEASUREMENT

Occupied BW Test Equipment Setup

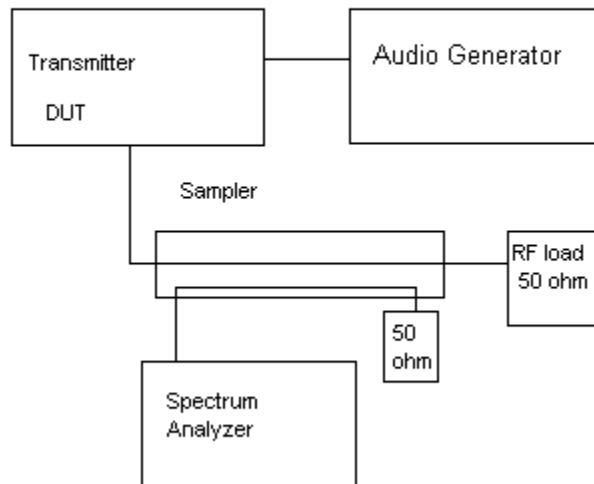



Certificate # 0955-01

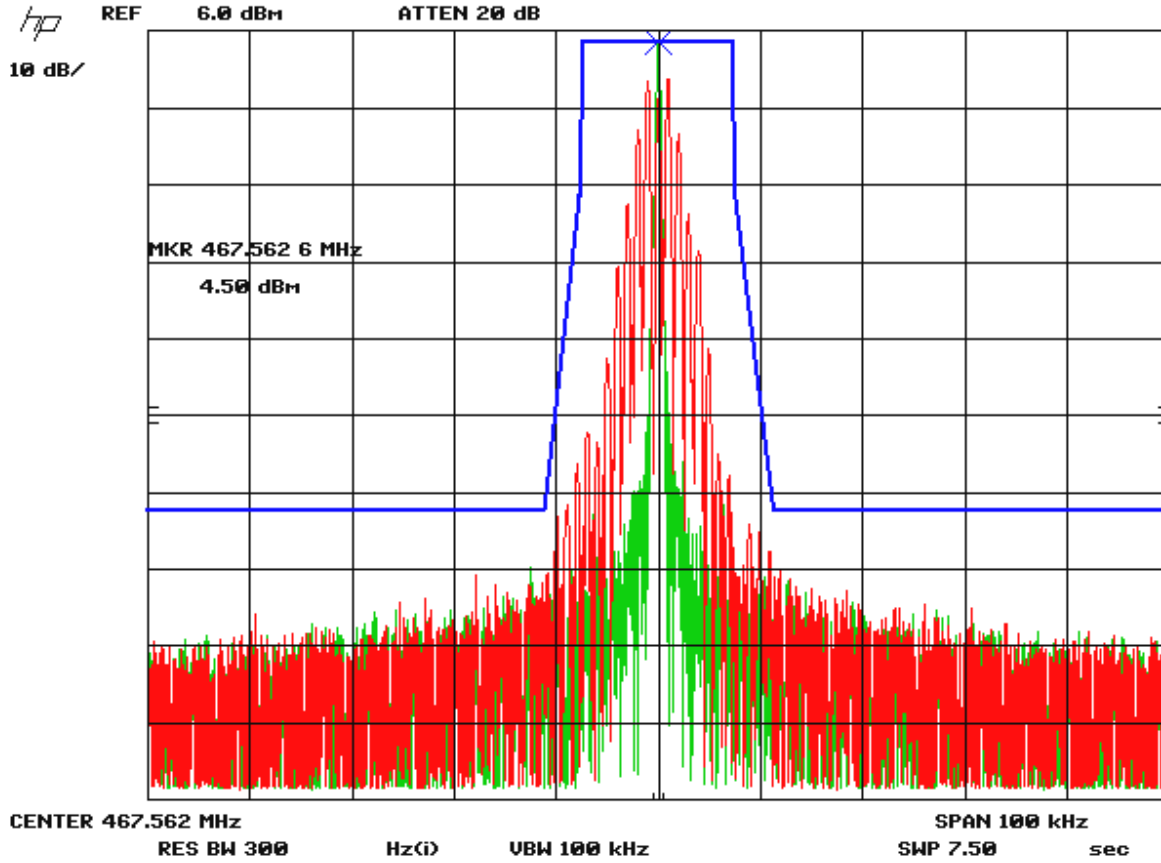

Applicant: COBRA ELECTRONICS CORPORATION
FCC ID: BBOLI6700
IC Cert #: 906B-LI6700
Report: W:\C\COBRA\2322AUT7\2322AUT7TestReport.doc



Certificate # 0955-01

SPURIOUS EMISSIONS AT ANTENNA TERMINALS (CONDUCTED)

2.1051 Not Applicable, no antenna terminal allowed.

Applicant: COBRA ELECTRONICS CORPORATION
FCC ID: BBOLI6700
IC Cert #: 906B-LI6700
Report: W:\C\COBRA\2322AUT7\2322AUT7TestReport.doc



Certificate # 0955-01

FIELD STRENGTH OF SPURIOUS EMISSIONS - TX

Rule Parts. No.: Part 2.1053
95.635(b)(7)

Requirements: GMRS: $43 + 10\log(.9) = 42.54$ dB

METHOD OF MEASUREMENT: The tabulated data shows the results of the radiated field strength emissions test. The spectrum was scanned from 30 MHz to at least the tenth harmonic of the fundamental. This test was conducted per TIA/EIA STANDARD 603 using the substitution method. Measurements were made at the test site of TIMCO ENGINEERING, INC. located at 849 NW State Road 45, Newberry, FL 32669.

Test Setup Diagram:

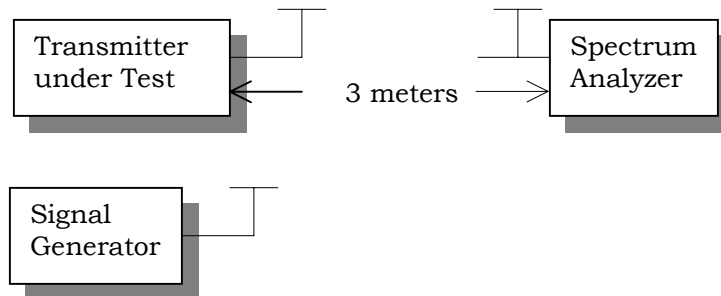

Test Data (GMRS):

Emission Frequency MHz	Ant. Polarity	dB Below Carrier (dBc)
462.7250	0	0
925.4500	V	55.9
1388.1750	V	67.8
1850.9000	V	66.7
2313.6250	V	67.5
2776.3500	H	62.6
3239.0750	H	55.6
3701.8000	H	59.9
4164.5250	H	62.0
4627.2500	V	69.1



Certificate # 0955-01

Rule Parts. No.: Part 2.1053
95.635(b)(7)

Requirements: FRS : $43 + 10\log(.3) = 37.77$ dB

Test Data (GMRS):

Emission Frequency MHz	Ant. Polarity	dB Below Carrier (dBc)
467.5625	0	0
935.1250	H	65.1
1402.6875	V	64.4
1870.2500	V	57.9
2337.8125	H	72.1
2805.3750	H	76.1
3272.9375	H	72.1
3740.5000	H	78.2
4208.0625	V	73.6
4675.6250	V	75.7

Applicant: COBRA ELECTRONICS CORPORATION
FCC ID: BBOLI6700
IC Cert #: 906B-LI6700
Report: W:\C\COBRA\2322AUT7\2322AUT7TestReport.doc



Certificate # 0955-01

FIELD STRENGTH OF SPURIOUS EMISSIONS - RX

Rules Part No.: 15.109, - RSS-210, RSS-310

Requirements:

Frequency	Limits
30 – 88	40.0 dBμV/m measured @ 3 meters
80 – 216	43.5 dBμV/m measured @ 3 meters
216 – 960	46.0 dBμV/m measured @ 3 meters
Above 960	54.0 dBμV/m measured @ 3 meters

Test Procedure: The procedure used was ANSI C63.4-2003. The frequency was scanned from 30 MHz to 1.0 GHz. When an emission was found, the table was rotated to produce the maximum signal strength. The DUT was measured in three (3) orthogonal planes.

Test Data:

Tuned Frequency MHz	Emission Frequency MHz	Meter Reading dBuV	Ant. Polarity	Coax Loss dB	Correction Factor dB	Field Strength dBuV/m	Margin dB
441.0	441.04	8.9	H	1.24	16.81	26.95	19.05
441.0	441.04	12.6	V	1.24	16.33	30.17	15.83
441.0	882.00	3.0	H	1.94	23.30	28.24	17.76
441.0	882.00	4.0	V	1.94	22.44	28.38	17.62
441.0	1,323.10	12.5	H	2.36	27.79	42.65	11.35
441.0	1,323.10	13.1	V	2.36	27.79	43.25	10.75
441.0	1,764.10	14.1	H	2.71	30.01	46.82	7.18
441.0	1,764.10	14.5	V	2.71	30.01	47.22	6.78
441.0	2,205.20	7.7	H	3.04	32.19	42.93	11.07
441.0	2,205.20	7.8	V	3.04	32.19	43.03	10.97
445.9	445.88	10.3	H	1.25	16.86	28.41	17.59
445.9	445.88	15.3	V	1.25	16.48	33.03	12.97
445.9	891.70	2.8	V	1.95	22.62	27.37	18.63
445.9	891.70	3.0	H	1.95	23.30	28.25	17.75
445.9	1,337.60	12.6	H	2.37	27.80	42.77	11.23
445.9	1,337.60	12.9	V	2.37	27.80	43.07	10.93
445.9	1,783.50	13.7	V	2.73	30.17	46.60	7.40
445.9	1,783.50	15.0	H	2.73	30.17	47.90	6.10
445.9	2,229.40	8.8	V	3.06	32.22	44.08	9.92
445.9	2,229.40	9.4	H	3.06	32.22	44.68	9.32

Applicant: COBRA ELECTRONICS CORPORATION
 FCC ID: BBOLI6700
 IC Cert #: 906B-LI6700
 Report: W:\C\COBRA\2322AUT7\2322AUT7TestReport.doc



Certificate # 0955-01

FREQUENCY STABILITY

Rule Parts. No.: Part 2.1055, Part 95.621(b), RSS-210

Requirements:)Temperature and voltage tests were performed to verify that the frequency remains within the 0.0005%, 5 ppm specification limit. The test was conducted as follows: The transmitter was placed in the temperature chamber at 25° C and allowed to stabilize for one hour. The transmitter was keyed ON for one minute during which four frequency readings were recorded at 15 second intervals. The worse case number was taken for temperature plotting. The assigned channel frequency was considered to be the reference frequency. The temperature was then reduced to -30° C after which the transmitter was again allowed to stabilize for one hour. The transmitter was keyed ON for one minute, and again frequency readings were noted at 15 second intervals. The worst case number was recorded for temperature plotting. This procedure was repeated in 10 degree increments up to + 50° C.

Method of Measurements: TIA/EIA 603.

Test Data:

Assigned Frequency (Ref. Frequency) (MHz)		
Temperature (°C)	Frequency (MHz)	Frequency Stability (PPM)
REFERENCE	467.562 938	00.00
-30	467.562 395	-1.16
-20	467.563 257	0.68
-10	467.563 584	1.38
0	467.563 867	1.99
+10	467.563 701	1.63
+20	467.563 284	0.74
+30	467.562 830	-0.23
+40	467.562 535	-0.86
+50	467.562 506	-0.92

Assigned Frequency (Ref. Frequency) (MHz)		
% Battery	Frequency (MHz)	Frequency Stability (PPM)
-15%	467.562 938	0.00
0		
+15%		

Applicant: COBRA ELECTRONICS CORPORATION
FCC ID: BBOLI6700
IC Cert #: 906B-LI6700
Report: W:\C\COBRA\2322AUT7\2322AUT7TestReport.doc



Certificate # 0955-01

TEST EQUIPMENT LIST

Device	Manufacturer	Model	Serial Number	Cal/Char Date	Due Date
3/10-Meter OATS	TEI	N/A	N/A	Listed 3/20/07	3/19/10
3-Meter OATS	TEI	N/A	N/A	Listed 1/11/06	1/10/09
Antenna: Biconnical	Eaton	94455-1	1057	CAL 12/12/05	12/12/07
Antenna: Biconnical	Eaton	94455-1	1096	CAL 10/11/06	10/11/08
Analyzer Blue Tower Quasi- Peak Adapter	HP	85650A	2811A01279	CAL 5/17/07	5/17/09
Analyzer Blue Tower RF Preselector	HP	85685A	2926A00983	CAL 5/17/07	5/17/09
Analyzer Blue Tower Spectrum Analyzer	HP	8568B	2928A04729 2848A18049	CAL 5/17/07	5/17/09
LISN	Electro-Metrics	ANS-25/2	2604	CAL 10/5/06	10/5/08
Antenna: Log- Periodic	Eaton	96005	1243	CAL 12/14/05	12/14/07

Applicant: COBRA ELECTRONICS CORPORATION
 FCC ID: BBOLI6700
 IC Cert #: 906B-LI6700
 Report: W:\C\COBRA\2322AUT7\2322AUT7TestReport.doc