

APPENDIX 6
TRANSMITTER TUNE-UP PROCEDURE

THREE (3) PAGE TUNE-UP PROCEDURE
FOLLOWS THIS SHEET

TRANSMITTER TUNE-UP PROCEDURE
FCC ID: BBOHH28

APPENDIX 6

F. TRANSMITTER TUNE-UP PROCEDURE

1. TRANSMITTER TUNE UP PROCEDURE

1-1. TEST SET UP

1-2. REFER TO THE DIAGRAM SHOWN BELOW.

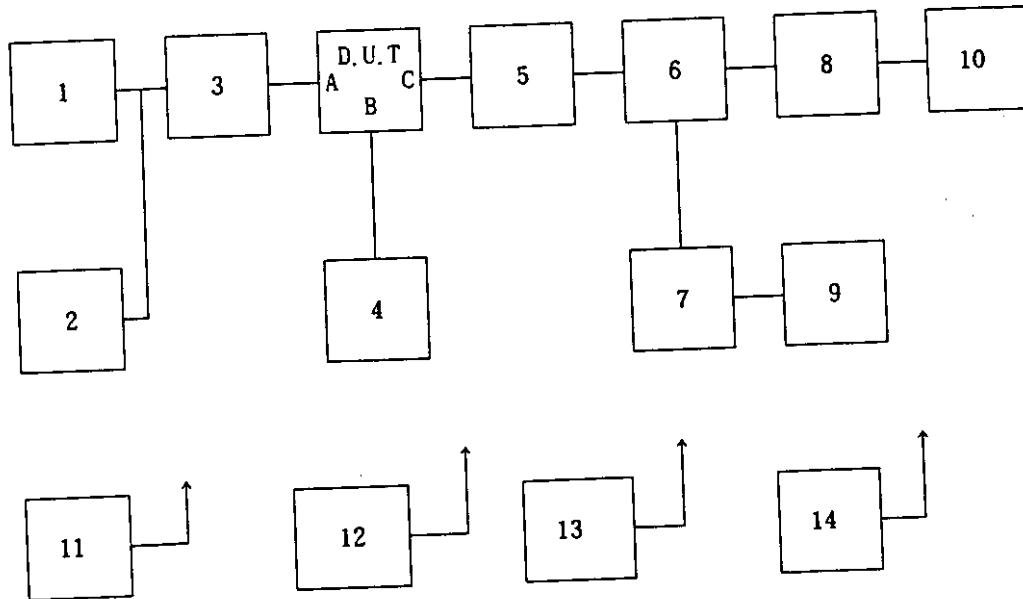

D.U.T : DEVICE UNDER TEST

A : MIC INPUT

B : POWER INPUT LEADS

C : ANTENNA JACK

| ITEM NO | DESCRIPTION | MANUFACTURER | MODEL NO. |
|---------|----------------------|------------------|-------------------|
| 1 | AUDIO OSCILLATOR | KIKUSUI | 417A |
| 2 | FREQUENCY COUNTER | TAKEDA RIKEN | TR5125 |
| 3 | AUDIO ATTENUATOR | TECH INSTRUMENTS | TE-111 |
| 4 | REGULATED DC SUPPELY | KIKUSUI | 7133A |
| 5 | RF WATTMETER | BIRD | 4311-200 |
| 6 | COUPLER | TOKYO DENPA | WV-1 |
| 7 | OSCILLOSCOPE | HEWLETT-PACKARD | 1710B |
| 8 | RF ATTENUATOR | FUJISOKU | FAT-515N |
| 9 | FREQUENCY COUNTER | TAKEDA RIKEN | TR5125 |
| 10 | SPECTRUM ANALYZER | HEWLETT-PACKARD | 8554B/8552A/8566B |
| 11 | OSCILLOSCOPE | HEWLETT-PACKARD | 1710B |
| 12 | FREQUENCY COUNTER | TAKEDA RIKEN | TR5125 |
| 13 | RF VOLTMETER | ANRITSU | M316A |
| 14 | DC VOLTMETER | TAKEDA RIKEN | TR6355 |

G. RECEIVER TUNE-UP PROCEDURE

1. RECEIVER CIRCUIT ALIGNMENT

1-1. TEST SET UP

1-2. REFER TO THE DIAGRAM SHOWN BELOW.

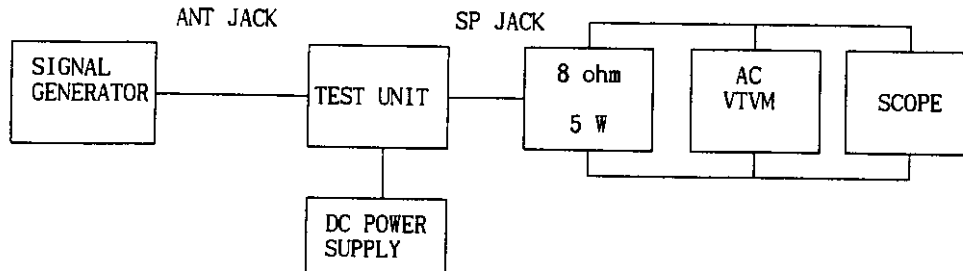

RECEIVER ALIGNMENT SET UP

2. SENSITIVITY ALIGNMENT

- 2-1. SET THE SIGNAL GENERATOR TO PROVIDE 27.185MHz, 1KHz 30% MOD. 1uV RF INPUT. PLACE THE CHANNEL SELECTOR IN CHANNEL 19 POSITION.
- 2-2. ADJUST L101, L201, L202 FOR MAXIMUM AUDIO OUTPUT ACROSS THE 8 ohm DUMMY LOAD RESISTER. THIS ALIGNMENT SHOULD BE PERFORMED BY GRADUALLY DECREASING THE SIGNAL OUTPUT SIGNAL TO A MINIMUM LEVEL REQUIRED FOR TUNING TO AVOID INACCURATE ALIGNMENT DUE TO AGC ACTION

3. SQUELCH CIRCUIT ALIGNMENT

- 3-1. SET THE SIGNAL GENERATOR TO PROVIDE 60dB, 1KHz, 30% MOD ANTENNA INPUT.
- 3-2. ROTATE THE SQUELCH CONTROL IN FULL CLOCKWISE DIRECTION.
- 3-3. TEMPORARILY ADJUST VR101 FOR MAXIMUM AUDIO OUTPUT, AND NOTE THE AUDIO OUTPUT LEVEL. THEN ADJUST RV550 SO THAT AUDIO OUTPUT JUST APPEARED.
- 3-4. NEXT, REDUCE THE ANTENNA INPUT SIGNAL LEVE TO 800uV-4000uV AND MAKE SURE THE AUDIO OUTPUT DECREASES TO ZERO.
- 3-5. REDUCE ANTENNA SIGNAL INPUT LEVEL TO ZERO, AND ADJUST THE SQ CONTROL UNTIL THE NOISE OUTPUT DECREASES TO JUST DISAPPEAR.

2. VCO VOLTAGE ADJUSTMENT

SELECT THE OPERATING CHANNEL ON CH 1.
CONNECT DC VOLTMETER(14) BETWEEN GROUND AND VCO POINT (BETWEEN R516 AND R608).
MAKE THE SET UNDER TX MODE.
TUNE THE VCO VOLTAGE TUNING IFT L601 TO OBTAIN 2.0 V READING OF DC VOLTMETER.
CHECK THE VOLTAGE OF CHANNEL 40 WHETHER THE READING IS IN BETWEEN 2.5 TO 5.5 V DC
UNDER RX MODE.
REMOVE DC VOLTMETER .

3. TRANSMITTER ALIGNMENT

- 3-1. CONNECT THE RF VOLTMETER (13) ON THE BASE OF Q704.
TRANSMIT ON CHANNEL 19 .
ADJUST L701, L702 FOR MAXIMUM READING ON RF VOLTMETER .
REPEAT AS NEEDED.
REMOVE RF VOLTMETER .
- 3-2. WITH THE RF POWER METER READING ON RF WATTMETER (5).
REPEAT IF NEEDED.
- 3-3. REPEAT STEPS 1 AND 2 IF NEEDED.
- 3-4. OUTPUT POWER READING ON RF WATTMETER (5) SHOULD BE FROM 3.6 TO 4.0 W.
IF POWER EXCEEDS 4.0 WATTS INCREASE R711 TO REDUCE POWER AND REPEAT
ALIGNMENT AGAIN.

4. FINAL CHECK

IN TRANSMIT ON ALL 40 CHANNELS

- 4-1. OUTPUT POWER SHOULD BE FROM 3.6 TO 4.0 WATTS .
- 4-2. FREQUENCY SHOULD BE WITHIN +400 Hz OF CHANNEL CENTER FREQUENCY .
- 4-3. STRENGTH OF SPURIOUS SIGNALS AS OBSERVED ON SPECTRUM ANALYZER (10)
SHOULD BE LESS 60 dB THAN THE TRANSMITTING FREQUENCY.

APPENDIX 7

CIRCUITS AND DEVICES TO STABILIZE FREQUENCY

All 40 channels of transmitting, and receiving, frequencies are provided by PLL (Phase Locked Loop) (IC501) circuitry.

The purpose of the PLL is to provide a multiple number of frequencies from a VCO (Voltage Controlled Oscillator) with quartz crystal accuracy and stability locked to crystal oscillator reference frequency.

The reference crystal oscillator frequency is 10.24 MHz.

CIRCUITS AND DEVICES TO
STABILIZE FREQUENCY

FCC ID: BBOHH28

APPENDIX 7

APPENDIX 8

1. Circuits For Suppression Of Spurious Radiation

The tuning circuit between frequency synthesizer and final amp Q702 and 3-stage "PI" network C718, C719, L711, C721, L712, C725, C722, L713, C723 in the Q704 output circuit serve to suppress spurious radiation. This network serves to impedance match Q704 to the antenna and to reduce spurious content to acceptable levels in the frequency synthesizer.

2. Circuits For Limiting Modulation

A portion of the modulating voltage is rectified by D401 which controls Q403 and Q404 to attenuate the mic amp IC401. The resulting feedback loop keeps the modulation below 100 percent for the inputs approximately 40 dB greater than that required to produce 50% modulation. The modulation attack time is about 50 mS and the modulation release time is about 300 mS.

3. Circuits for Limiting Power

During factory alignment, the series resistor of TX power amp Q704 is selected to limit the available power to slightly less than 4 watts. The tuning is adjusted so that the actual power is from 3.6 to 3.9 watts. There are no other additional controls for adjusting the TX output power.

DEVICES AND CIRCUITS TO SUPPRESS
SPURIOUS RADIATION AND LIMIT
MODULATION

FCC ID: BBOHH28

APPENDIX 8

Block Diagram

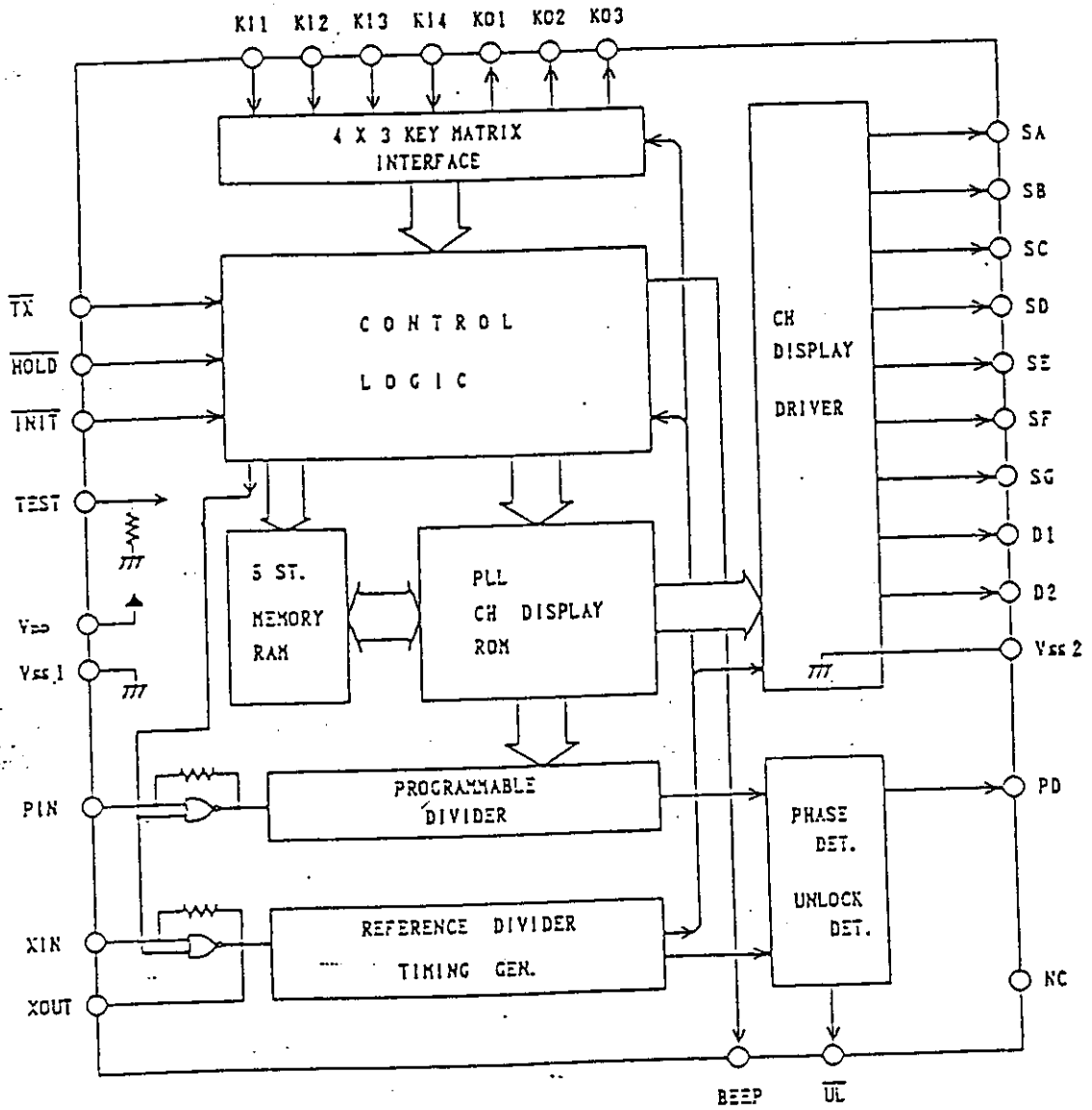

Pin Descriptions

TX: Transmit/receive select
HOLD: Hold mode select
INIT: Reset line
TEST: Test point (input)
VDD, VSS1, VSS2: Power supply
PIN: Programmable divider input
XIN, XOUT: Crystal oscillator input,
output (e.g. 10.240MHz)

UL: Unlock detected output
PD: Charge pump output
NC: NC Pin
SA to SG: Segment drivers (for display)
D1, D2: Digit output (for display)
K11 to 4: Key inputs
K01 to 3: Key scan outputs
BEEP: Beep-tone control output

Pin Assignment: DIP30S (shrink) package

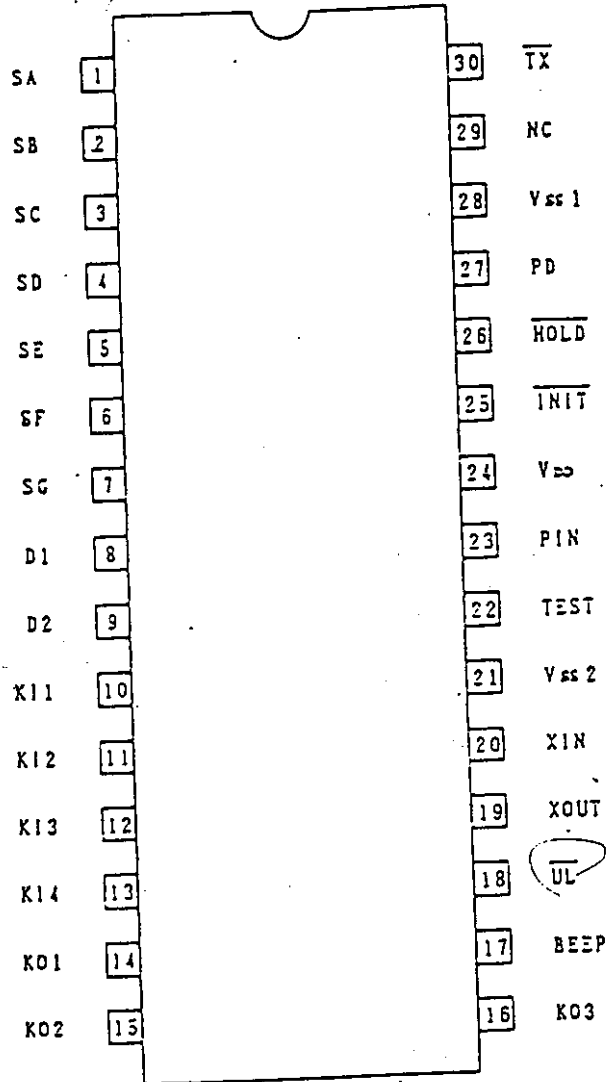

top view

Key Matrix

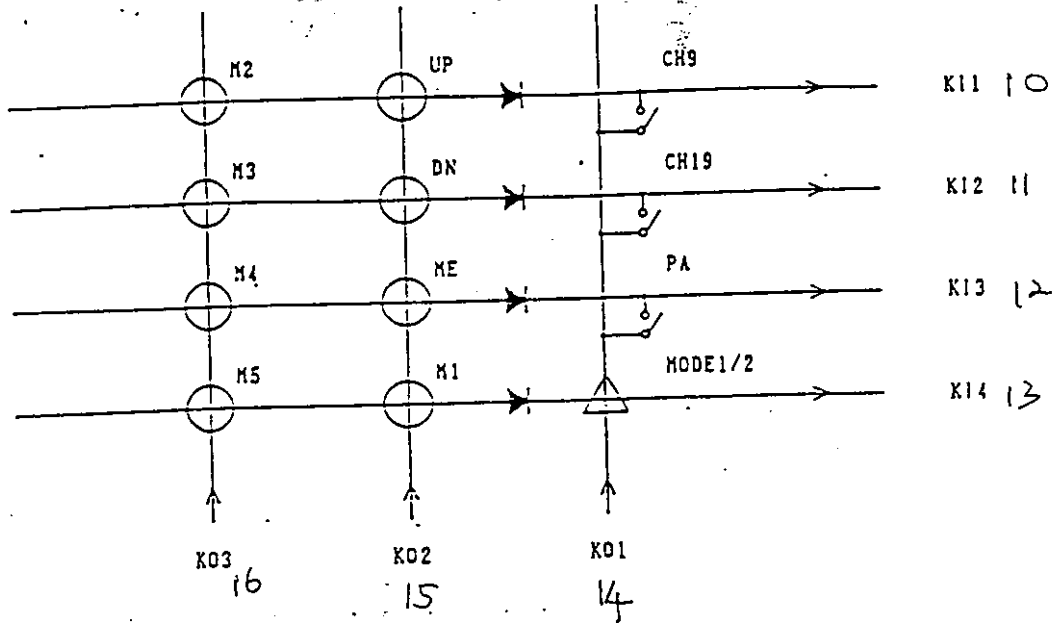

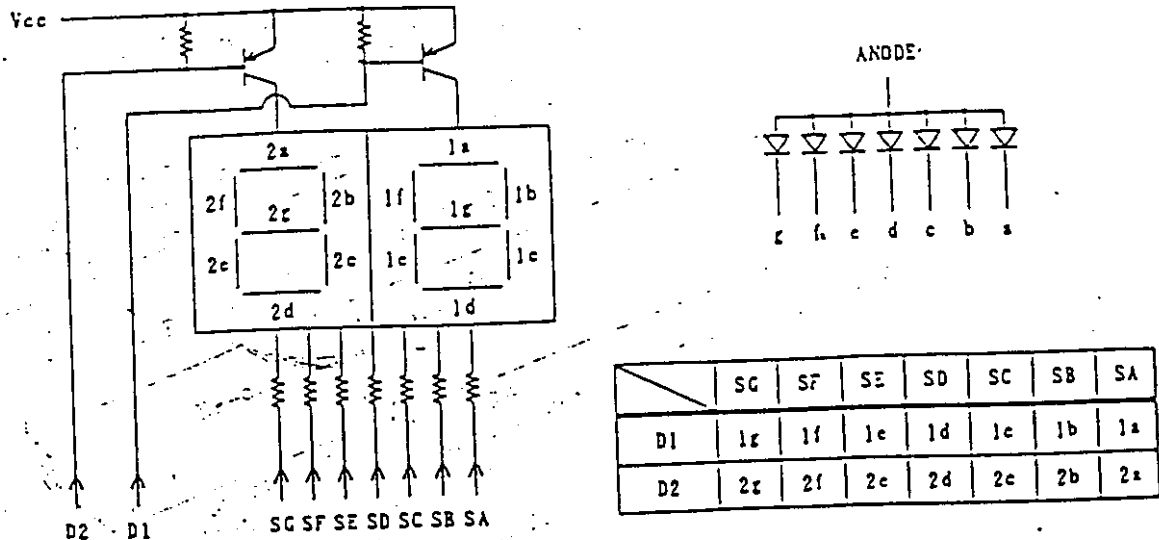

- CH9: Emergency CH9 select
- CH19: Emergency CH19 select
- PA: Public announcement display
- MODE 1/2: Display mode
- UP: Channel up/scan
- DN: Channel down/scan
- ME: Channel memory enable
- M1 to M5: Channel memory recall
- UP/DN/ME/M1 to M5: Momentary switch
- CH9/CH19/PA: Sliding switch
- MODE 1/2: Diode

LED Display Configuration (Common anode/7 segment)

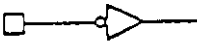
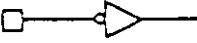

Pin Description

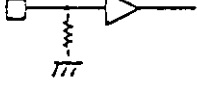
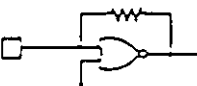
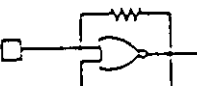
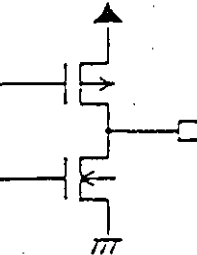
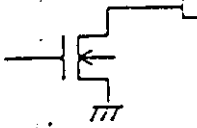
| Pin Name | Pin No. | Type | Description |
|--------------------------|---------|---|---|
| $\overline{\text{TX}}$ | 30 |  | Transmit/receive select $\overline{\text{TX}}="0"$... Transmit, $\overline{\text{TX}}="1"$... Receive |
| $\overline{\text{HOLD}}$ | 26 |  | Hold mode select $\overline{\text{HOLD}}="0"$... Hold mode select ="1" ... Normal mode select |
| $\overline{\text{INIT}}$ | 25 |  | Reset line $\overline{\text{INIT}}="0"$... Reset |
| TEST | 22 |  | Test point (input) Tie to ground or leave floating |
| V_{DD} | 24 | | Power supply (+) Normal mode: 5.0 to 8.0V Hold mode: $\geq 3.0\text{V}$ |
| V_{SS2} | 21 | | Channel display LED driver Ground |
| PIN | 23 |  | Programmable divider input 150mVrms min Hold mode: Programmable divider is disabled. |
| XIN | 20 |  | Crystal oscillator Frequency: 10.24MHz Hold mode: Oscillator is disabled. |
| XOUT | 19 | | |
| PD | 27 |  | Charge pump output from the phase comparator <ul style="list-style-type: none"> f_V is obtained by dividing the PIN frequency input by N (programmable divider value) f_R is the reference signal (reference divider output) $f_V > f_R$ or leading: Positive pulses $f_V < f_R$ or lagging: Negative pulses $f_V = f_R$ and phase matched: High impedance Hold mode: High impedance |
| V_{SS1} | 28 | | . PLL circuit and controller Ground |
| NC | 29 | | . No-connection |
| $\overline{\text{UL}}$ | 18 |  | Unlock detected output Low level: See Unlock Detected Output ($\overline{\text{UL}}$) for detail. Open: Locked |

Continued from preceding page.

| Pin Name | Pin No. | Type | Description |
|------------------|----------------|------|--|
| BEEP | 17 | | Beep-tone control output Open: See Beep-tone Control Output for detail. Low level: Hold mode |
| SA to SG | 1 to 7 | | Segment drivers for the display (Common anode/7 segments) |
| D1 D2 | 8 9 | | Digit output (150Hz) for the display (Common anode/7 segments) Hold mode: Tr goes off. |
| KI1 to KI4 | 10 to 13 | | Key inputs Input from the key matrix |
| KO1 to KO3 | 14 to 16 | | Key scan output (75Hz) Output to the key matrix Hold mode: Low (scanning stops) |

Operation

(1) Channel selection (up/down)

The unlock detected line (\overline{UL}) is asserted (low) when the UP (or DN) key is pressed and deactivated 25ms after the key is released (see diagram below). The beep-tone control line (BEEP) is asserted (open) for 50msec after each new channel is selected (see diagram below).

1) Manual scanning (up/down)

Pressing the UP key increments by one channel and pressing the DN key decrements by one channel.

When scanning reaches the end of the band, it automatically wraps around to the beginning.

2) Auto scanning (up/down)

Holding the UP (or DN) key down for 500msec or longer starts auto scanning. For both up and down scanning, each channel takes 100msec to scan.

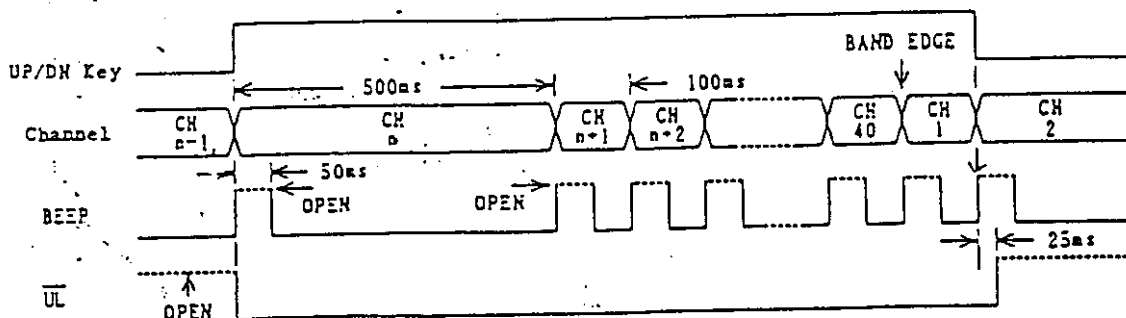

(2) Selecting an emergency channel (CH9/CH19).

If the CH9 or CH19 switch is turned on, the LC7185 does the following:

- . Stores the value of the previous channel
- . Asserts the beep-tone control line for 50msec
- . Disables the UP/DN, M1 to M5, and ME switches
- . Causes either "9" or "19" to blink on the display
- . Keep the emergency channel open until the CH9 or CH19 switch is turned off.

After the CH9 or CH19 switch is turned back off the beep-tone control line is asserted for 50msec and the LC7185 reopens the previous channel.

Note the CH9 has a higher priority over CH19. As a result, if both switches are turned on, CH9 will be opened.

As shown in the diagram, the \overline{UL} line is asserted for 25ms after the CH9 or CH19 switch is turned off or on.

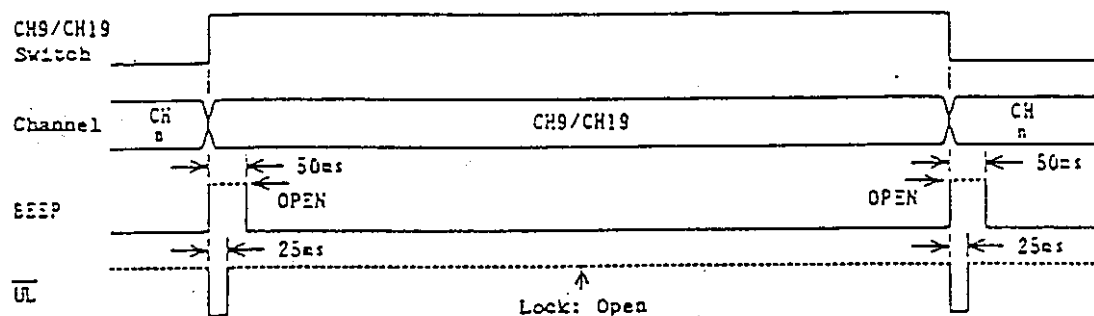

(3) Public Announcement (PA) mode

When the PA switch is turned on, the LC7185 does the following:

- . Stores the value of the previous channel
- . Disables all keys
- . Causes "PA" to be displayed
- . Stays in PA mode until the PA switch is turned off.

When the PA switch is turned back off, the LC7185 leaves PA mode and reopens the previous channel.

As shown in the diagram, the \overline{UL} line is asserted while the PA switch is turned on.

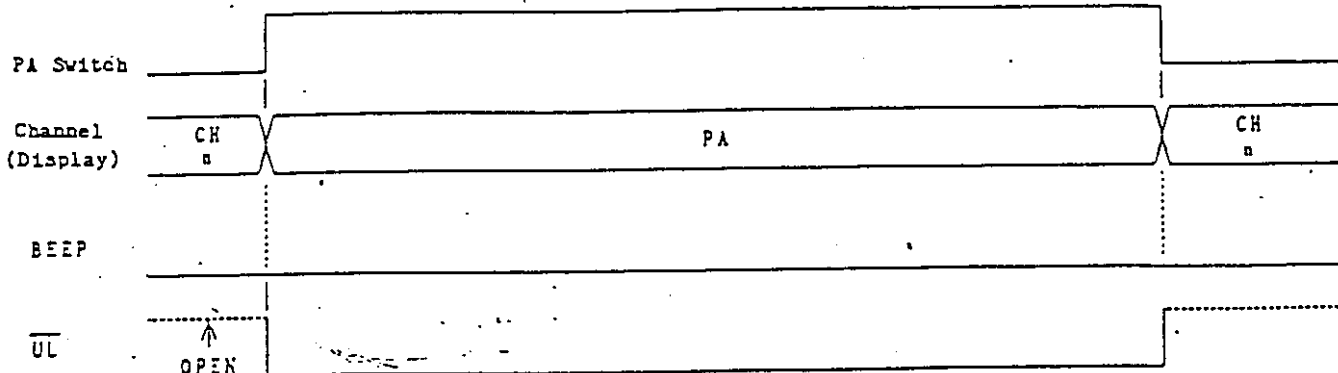

(4) Transmit/Receive Selection

When the TX line is asserted, the LC7185 enters TX mode. The LC7185 will only leave this mode if the PA switch is pressed or the TX line is deactivated.

As shown in the diagram, the UL line is asserted for 25ms after the TX line is asserted or deactivated.

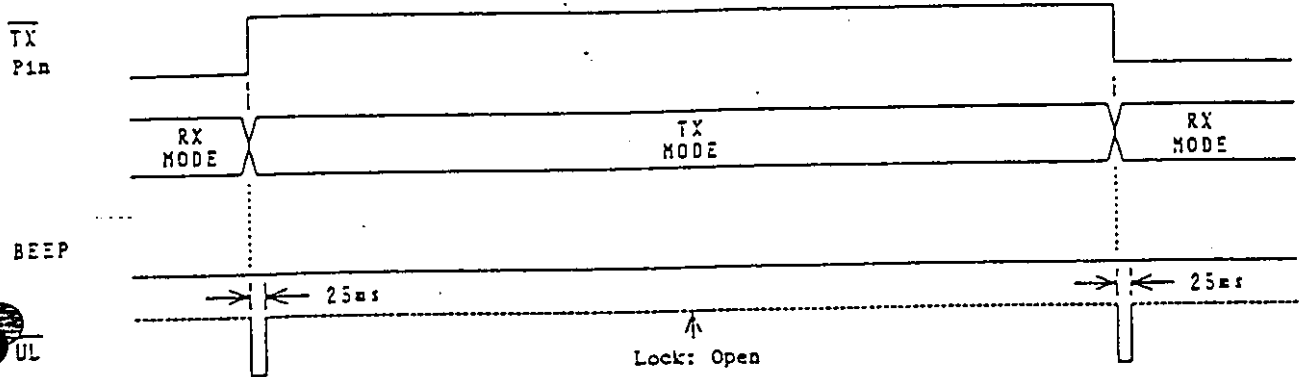

(5) Channel Preset/Recall Facility

1. The LC7185 allows up to 5 channels to be preset (assigned to M1 to M5).
 . After a reset, M1 to M5 are assigned to CH33.

2. Recalling preset channels

- . A preset channel is recalled by pressing one of the preset memory keys (M1 to M5)* to which the channel was previously assigned.
 - . Presetting channel (assigning keys) are covered in the next section.
- There are two different display modes as shown below.

Mode 1 (without diode)

Each time a key is pressed (e.g. M1), the new channel is displayed.

Example: Display 21 → 15

Key

M 1

Mode 2 (with diode)

Each time a key is pressed (e.g. M1), a key mnemonic (e.g. "P1") is displayed for 400msec, then the new channel is displayed.

Example: Display 21 → P1 → 15

Key

M 1

400ms

3. Presetting channels

Presetting a channel is done in the following way. First select the channel to be preset, then hold down the ME key and press the preset memory key (M1 to M5)* to which you would like to assign the current channel.

In the following cases, a channel will not be preset:

- . 9 seconds elapse after the ME key is pressed and one of M1 to M5 is pressed.
- . Emergency channels CH9 or CH19 are currently selected
- . The TX line is asserted.
- . The PA switch is turned on (PA mode).
- . The HOLD line is asserted (hold mode).

There are two different display modes as shown below.

Mode 1 (without diode)

The current channel is displayed throughout the preset process.

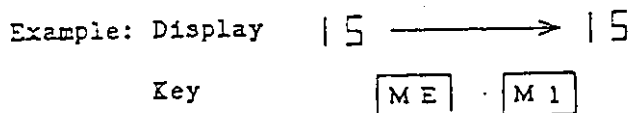

Mode 2 (with diode)

When the ME key is held down, "PE" is flashed on the display. Once a preset memory key is pressed (e.g. M1), the key mnemonic (e.g. "P1") is displayed for 400msec before the current channel is redisplayed.

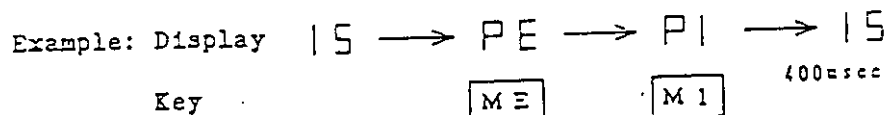

* Note that if two or more keys are pressed at the same time, priority is assigned as follows:

M1>M2>M3>M4>M5

(6) Beep-tone Control Output

After each of the following events, the BEEP line is asserted for 50msec:

- . A reset (e.g. battery replacement)
- . Any key press associated with the channel memory
- . Any emergency channel switch activation
- . A new channel is selected.
- . Leaving hold mode

(7) Unlock Detected Output (\overline{UL})

In the following cases, the \overline{UL} line is asserted for the duration indicated.

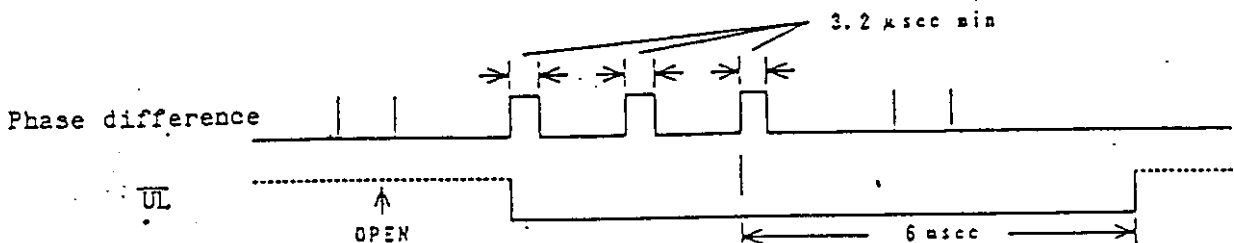

- . When the phase difference between the programmable and reference divider outputs exceeds 3.2μsec. The \overline{UL} line is held low for 6msec after the last out-of-range phase sample is detected, as shown below.
- . After a new transmit/receive or channel selection. The \overline{UL} line is asserted for 25msec.
- . While the PA switch is turned on.

(8) Key Matrix

It is normal to put diodes in series with the key scanning lines to avoid creating a short with the output lines.
 But K01, K02 and K03 lines don't need diodes.

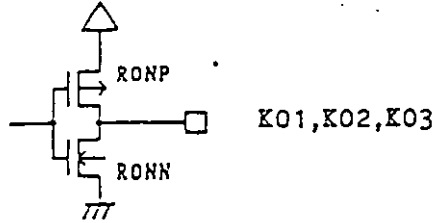

R_{ONP}, R_{ONN} : ON impedance

| | min | typ | max | [kohm] |
|-----------|-----|-----|-----|--------|
| R_{ONP} | 0.5 | 1.0 | 2.0 | |
| R_{ONN} | 30 | 50 | 70 | |
| R_{PdN} | 30 | 50 | 70 | |

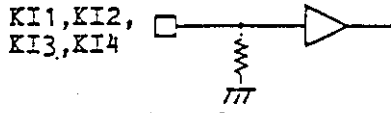

R_{PdN} : Pull-down resistor

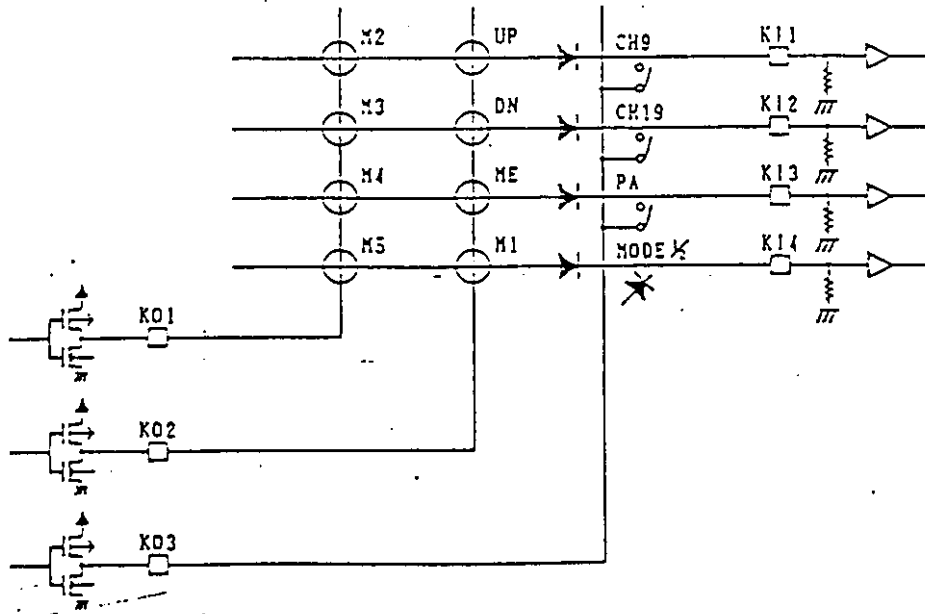

Hold Mode

The LC7185 enters hold mode when the $\overline{\text{HOLD}}$ line is asserted. In this mode, the channel preset/recall RAM is not affected.

(1) System status

The LC7185 will remain in hold mode until the $\overline{\text{HOLD}}$ line is deactivated or a reset occurs ($\overline{\text{INIT}}$ line is asserted). The programmable divider, crystal oscillator, and reference divider are all inhibited. Signal output levels are shown below.

PD: High impedance

$\overline{\text{UL}}$: V_{SS} (ground)

D1, D2: High impedance

BEEP: V_{SS}

KO1 to KO3: V_{SS}

When the LC7185 leaves hold mode, the previously selected channel is reopened.

(2) Reset

To reset the chip, assert the $\overline{\text{INIT}}$ line,

Reset state:

- . CH9 is selected.

- . Preset memory keys are all set to CH33.

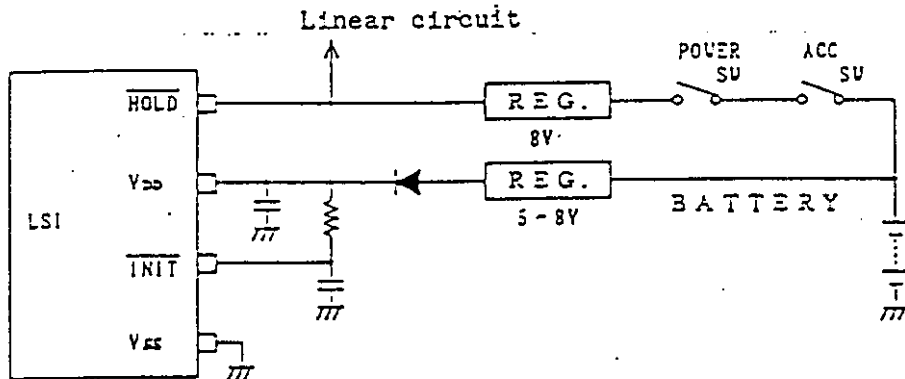

(3) Timing Requirements for Hold Mode

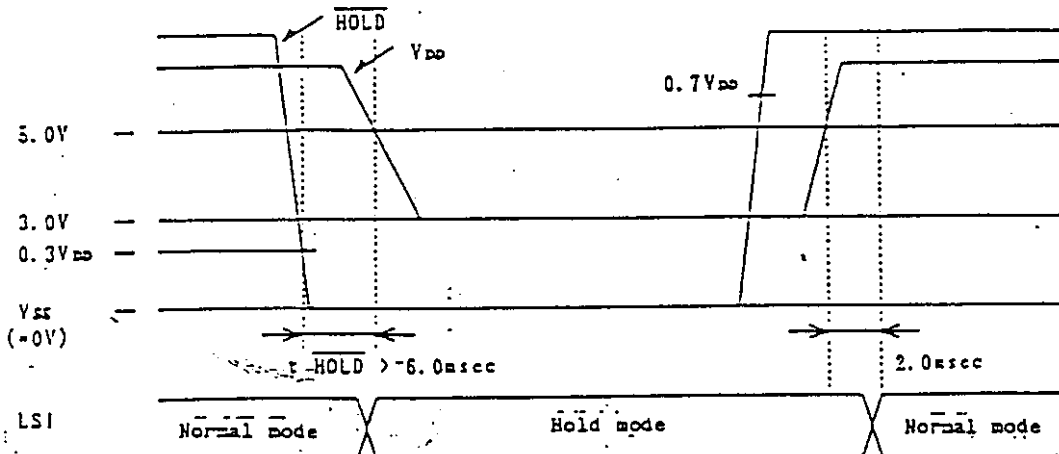

V_{DD} must remain at 5.0V or higher (crystal oscillator requirement) for 6.0msec (t_{HOLD}) after the HOLD line is asserted ($HOLD < 0.3V_{DD}$). After this V_{DD} may go as low as 3.0V.

There are no constraints on timing when the chip is leaving hold mode. The signals can be activated in one of two orders.

- 1) If HOLD is already deactivated ($> 0.7V_{DD}$), the LC7185 leaves hold mode within 2.0msec after V_{DD} rises to $> 5.0V$.
- 2) If V_{DD} is $> 5.0V$, the LC7185 enters normal mode within 2.0msec after HOLD is deactivated.

(4) Reset Timing

- 1) Reset timing (e.g. battery replacement)

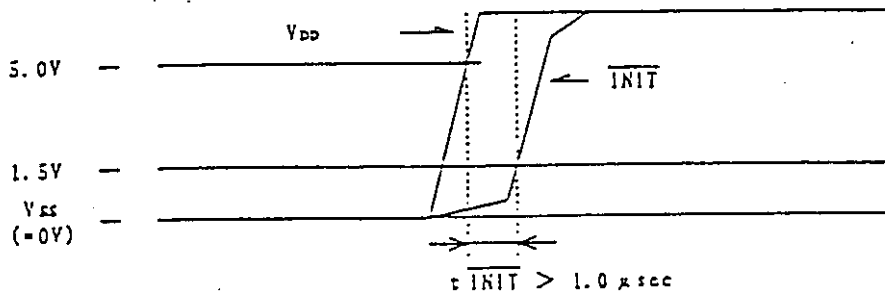

Note: t_{INIT} should be greater than 1.0msec.

- 2) Reset caused by a sudden voltage (V_{DD}) drop

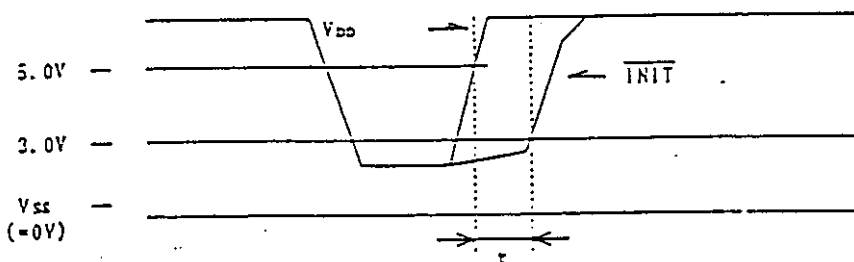

Note: If V_{DD} drops momentarily down to less than 3.0V and rises up to more than 5.0V ($t > 1.0msec$), a reset may be generated.

Frequency Table (U.S.A.; LC7185-8750)

| CHANNEL | FREQUENCY (MHz) | RX ($\overline{TX} = 1$) | | TX ($\overline{TX} = 0$) | |
|---------|-----------------|----------------------------|---------|----------------------------|---------|
| | | N | F v c o | N | F v c o |
| 1 | 26.965 | 6508 | 16.27 | 5393 | 13.4825 |
| 2 | 26.975 | 6512 | 16.28 | 5395 | 13.4875 |
| 3 | 26.985 | 6516 | 16.29 | 5397 | 13.4925 |
| 4 | 27.005 | 6524 | 16.31 | 5401 | 13.5025 |
| 5 | 27.015 | 6528 | 16.32 | 5403 | 13.5075 |
| 6 | 27.025 | 6532 | 16.33 | 5405 | 13.5125 |
| 7 | 27.035 | 6536 | 16.34 | 5407 | 13.5175 |
| 8 | 27.055 | 6544 | 16.36 | 5411 | 13.5275 |
| 9 | 27.065 | 6548 | 16.37 | 5413 | 13.5325 |
| 10 | 27.075 | 6552 | 16.38 | 5415 | 13.5375 |
| 11 | 27.085 | 6556 | 16.39 | 5417 | 13.5425 |
| 12 | 27.105 | 6564 | 16.41 | 5421 | 13.5525 |
| 13 | 27.115 | 6568 | 16.42 | 5423 | 13.5575 |
| 14 | 27.125 | 6572 | 16.43 | 5425 | 13.5625 |
| 15 | 27.135 | 6576 | 16.44 | 5427 | 13.5675 |
| 16 | 27.155 | 6584 | 16.46 | 5431 | 13.5775 |
| 17 | 27.165 | 6588 | 16.47 | 5433 | 13.5825 |
| 18 | 27.175 | 6592 | 16.48 | 5435 | 13.5875 |
| 19 | 27.185 | 6596 | 16.49 | 5437 | 13.5925 |
| 20 | 27.205 | 6604 | 16.51 | 5441 | 13.6025 |
| 21 | 27.215 | 6608 | 16.52 | 5443 | 13.6075 |
| 22 | 27.225 | 6612 | 16.53 | 5445 | 13.6125 |
| 23 | 27.255 | 6624 | 16.56 | 5451 | 13.6275 |
| 24 | 27.235 | 6616 | 16.54 | 5447 | 13.6175 |
| 25 | 27.245 | 6620 | 16.55 | 5449 | 13.6225 |
| 26 | 27.265 | 6628 | 16.57 | 5453 | 13.6325 |
| 27 | 27.275 | 6632 | 16.58 | 5455 | 13.6375 |
| 28 | 27.285 | 6636 | 16.59 | 5457 | 13.6425 |
| 29 | 27.295 | 6640 | 16.60 | 5459 | 13.6475 |
| 30 | 27.305 | 6644 | 16.61 | 5461 | 13.6525 |
| 31 | 27.315 | 6648 | 16.62 | 5463 | 13.6575 |
| 32 | 27.325 | 6652 | 16.63 | 5465 | 13.6625 |
| 33 | 27.335 | 6656 | 16.64 | 5467 | 13.6675 |
| 34 | 27.345 | 6660 | 16.65 | 5469 | 13.6725 |
| 35 | 27.355 | 6664 | 16.66 | 5471 | 13.6775 |
| 36 | 27.365 | 6668 | 16.67 | 5473 | 13.6825 |
| 37 | 27.375 | 6672 | 16.68 | 5475 | 13.6875 |
| 38 | 27.385 | 6676 | 16.69 | 5477 | 13.6925 |
| 39 | 27.395 | 6680 | 16.70 | 5479 | 13.6975 |
| 40 | 27.405 | 6684 | 16.71 | 5481 | 13.7025 |

$V_{co} (TX) = RF \div 2$

$V_{co} (RX) = RF - 10.695 \text{ MHz (IF)}$

CH1: $V_{co} (TX) = 26.965 \div 2 = 13.4825$

$V_{co} (RX) = 26.965 - 10.695 = 16.27$

Electrical Characteristics

Absolute maximum ratings at $T_a=25^{\circ}\text{C}$, $V_{SS}=0\text{V}$

| | | | min | typ | max | unit |
|-----------------------------|-----------------|--|------|-----|--------------|--------------------|
| Supply Voltage | $V_{DD\max}$ | V_{DD} | -0.3 | | 9.0 | V |
| Input Voltage | $V_{IN(1)\max}$ | HOLD, TX | -0.3 | | 15 | V |
| | $V_{IN(2)\max}$ | Input pins other than $V_{IN(1)\max}$ | -0.3 | | $V_{DD}+0.3$ | V |
| Output Voltage | $V_{O(1)\max}$ | SA, SB, SC, SD, SE, SF, SG, D1, D2 | -0.3 | | 15 | V |
| | $V_{O(2)\max}$ | UL, BEEP | -0.3 | | 15 | V |
| | $V_{O(3)\max}$ | PD | -0.3 | | $V_{DD}+0.3$ | V |
| | $V_{O(4)\max}$ | Output pins other than mentioned above | -0.3 | | $V_{DD}+0.3$ | V |
| Output Current | $I_{O(1)\max}$ | SA, SB, SC, SD, SE, SF, SG | 0 | | 30 | mA |
| | $I_{O(2)\max}$ | D1, D2 | | | 10 | mA |
| | $I_{O(3)\max}$ | UL | 0 | | 20 | mA |
| | $I_{O(4)\max}$ | BEEP | 0 | | 10 | mA |
| Allowable Power Dissipation | $P_d\max$ | ($T_a \leq 85^{\circ}\text{C}$) | | | 350 | mW |
| Operating Temperature | T_{opg} | | -40 | | +85 | $^{\circ}\text{C}$ |
| Storage Temperature | T_{stg} | | -55 | | +125 | $^{\circ}\text{C}$ |

Allowable operating conditions at $T_a=-40$ to $+85^{\circ}\text{C}$, $V_{SS}=0\text{V}$

| | | | | | | |
|--------------------------------|--------------|--|-------------|-------|-------------|------|
| Supply Voltage | V_{DD} | | 5.0 | | 8.0 | V |
| "H"-Level Input Voltage | $V_{IH(1)}$ | HOLD, TX | $0.7V_{DD}$ | | 12 | V |
| | $V_{IH(2)}$ | INIT | 3.0 | | V_{DD} | V |
| | $V_{IH(3)}$ | KI1, KI2, KI3, KI4 | $0.6V_{DD}$ | | V_{DD} | V |
| "L"-Level Input Voltage | $V_{IL(1)}$ | HOLD, TX | 0 | | $0.3V_{DD}$ | V |
| | $V_{IL(2)}$ | INIT | 0 | | 1.5 | V |
| | $V_{IL(3)}$ | KI1, KI2, KI3, KI4 | 0 | | $0.4V_{DD}$ | V |
| Output Voltage | $V_{OUT(1)}$ | SA, SB, SC, SD, SE, SF, SG, D1, D2 | 0 | | 13 | V |
| | $V_{OUT(2)}$ | UL, BEEP | 0 | | 8 | V |
| Input Frequency | $f_{IN(1)}$ | XIN(sine wave, capacitor coupled) | 1.0 | 10.24 | 15 | MHz |
| | $f_{IN(2)}$ | PIN(sine wave, capacitor coupled) | 10 | | 30 | MHz |
| Input Amplitude | $V_{IN(1)}$ | XIN(sine wave, capacitor coupled) | 0.5 | | 1.5 | Vrms |
| | $V_{IN(2)}$ | PIN(sine wave, capacitor coupled) | 0.15 | | 1.5 | Vrms |
| Required Oscillating Frequency | X'tal | XIN, XOUT ($C_I \leq 50\text{ohms}$) | 5.0 | 10.24 | 15 | MHz |

Electrical characteristics at under allowable operating conditions

| | | | | | | |
|------------------------------|-------------|--------------------------|------------------|----|-----|------|
| Internal Feedback Resistance | $R_f(1)$ | XIN | | | 1.0 | Mohm |
| | $R_f(2)$ | PIN | | | 500 | kohm |
| Pull-down Resistor | R_{pdN} | KI1, KI2, KI3, KI4, TEST | 30 | 50 | 70 | kohm |
| "H"-Level Input Current | $I_{IH(1)}$ | HOLD, TX | $V_I=12\text{V}$ | | 5.0 | uA |
| | $I_{IH(2)}$ | INIT | $V_I=V_{DD}$ | | 5.0 | uA |
| | $I_{IH(3)}$ | XIN | $V_I=V_{DD}$ | | 20 | uA |
| | $I_{IH(4)}$ | PIN | $V_I=V_{DD}$ | | 40 | uA |

Continued on next page.

Continued from preceding page.

| | | | min | typ | max | unit |
|------------------------------------|--------------|--|------------------------------------|----------------|----------------|--------------------|
| "L"-Level Input Current | $I_{IL}(1)$ | $\overline{HOLD}, \overline{TX}, V_I = V_{SS}$ | | | 5.0 | μA |
| | $I_{IL}(2)$ | $\overline{INIT} V_I = V_{SS}$ | | | 5.0 | μA |
| | $I_{IL}(3)$ | $XIN V_I = V_{SS}$ | | | 2.0 | μA |
| | $I_{IL}(4)$ | $PIN V_I = V_{SS}$ | | | 4.0 | μA |
| "H"-Level Output Voltage | $V_{OH}(1)$ | $KO1, KO2, KO3 I_O = 1mA$ | $V_{DD} - 2.0$ | $V_{DD} - 1.0$ | $V_{DD} - 0.5$ | V |
| | $V_{OH}(2)$ | $PD I_O = 1mA$ | $V_{DD} - 1.0$ | | | V |
| "L"-Level Output Voltage | $V_{OL}(1)$ | $KO1, KO2, KO3 I_O = 20\mu A$ | 0.6 | 1.0 | 1.4 | V |
| | $V_{OL}(2)$ | $PD I_O = 0.5mA$ | | | 1.0 | V |
| | $V_{OL}(3)$ | $BEEP I_O = 2mA$ | | | 1.0 | V |
| | $V_{OL}(4)$ | $SA, SB, SC, SD, SE, SF, SG I_O = 20mA$ | | | 1.0 | V |
| | $V_{OL}(5)$ | $D1, D2 I_O = 5mA$ | | | 1.0 | V |
| | $V_{OL}(6)$ | $\overline{UL} I_O = 10mA$ | | | 5.0 | μA |
| Output Leakage Current | $I_{OFF}(1)$ | $SA, SB, SC, SD, SE, SF, SG, D1, D2 V_O = 13V$ | | | 5.0 | μA |
| | $I_{OFF}(2)$ | $\overline{UL}, BEEP V_O = 8V$ | | | 10.0 | nA |
| "H"-Level Tristate Leakage Current | I_{OFFH} | $PD V_O = V_{DD}$ | 0.01 | 10.0 | | nA |
| "L"-Level Tristate Leakage Current | I_{OFFL} | $PD V_O = V_{SS}$ | 0.01 | 10.0 | | nA |
| Supply Current | $I_{DD}(1)$ | Normal mode *1(PLL operates) | | 10 | 15 | mA |
| | $I_{DD}(2)$ | Hold mode *2(memory backup) | $V_{DD} = 3.0V$ $V_{DD} = 8.0V$ | | 5 15 | μA μA |

*1 $f_{IN(2)} = 20MHz(PIN)$
 $V_{IN(2)} = 0.15V_{rms}$
 $X'_{tal} = 10.240MHz$
 $\overline{TX} = \overline{HOLD} = \overline{INIT} = V_{DD}$
 Other inputs = V_{SS}
 Other outputs = open

*2 $\overline{HOLD} = V_{SS}$
 $\overline{TX} = \overline{INIT} = V_{DD}$
 Other inputs = V_{SS}
 Other outputs = open

APPENDIX 10
FINAL RF AMPLIFIER DATA SHEETS

FOUR (4) PAGES FOR 2SC2078 FOLLOW THIS SHEET

FINAL RF AMP DATA SHEET
FCC ID: BBOHH28

APPENDIX 10

B TRANSCEIVER TX FINAL AMPLIFIER APPLICATION.
F TRANSCEIVER APPLICATION.

FEATURES

- Recommended for Output Stage Application of AM 4W Transmitter.
- High Power Gain.
- Wide Area of Safe Operation.

MAXIMUM RATINGS (Ta=25°C)

| CHARACTERISTIC | SYMBOL | RATING | UNIT |
|---|------------------|---------|------|
| Collector-Base Voltage | V _{CB0} | 80 | V |
| Collector-Emitter Voltage (R _{BE} =50 Ω) | V _{CER} | 80 | V |
| Emitter-Base Voltage | V _{EB0} | 4 | V |
| Collector Current | I _C | 4 | A |
| Emitter Current | I _E | -4 | A |
| Collector Power Dissipation (T _C =25°C) | P _C | 10 | W |
| Junction Temperature | T _J | 150 | °C |
| Storage Temperature Range | T _{stg} | -55-150 | °C |

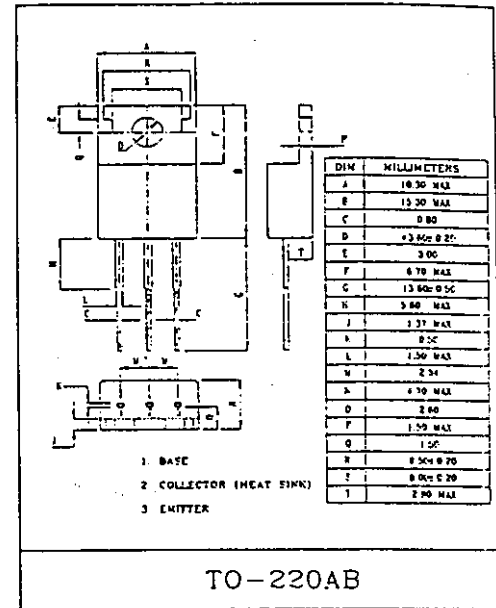

ELECTRICAL CHARACTERISTICS (Ta=25°C)

| CHARACTERISTIC | SYMBOL | TEST CONDITION | MIN. | TYP. | MAX. | UNIT | |
|--------------------------------------|----------------------|---|---|------|------|------|---|
| Collector Cut-off Current | I _{CBO} | V _{CB} =30V, I _E =0 | - | - | 10 | μA | |
| Breakdown Voltage | Collector-Emitter | V _{(BR)CER} | I _C =10mA, R _{BE} =50 Ω | 80 | - | - | V |
| | Emitter-Base | V _{(BR)EBO} | I _E =1.0mA, I _C =0 | 4 | - | - | V |
| Current Gain | h _{FE} | V _{CE} =5V, I _C =0.5A | 100 | - | 200 | | |
| Collector-Emitter Saturation Voltage | V _{CE(sat)} | I _C =3A, I _B =0.3A | - | - | 1.5 | V | |
| Transition Frequency | f _T | V _{CE} =5V, I _C =500mA | 100 | - | - | MHz | |
| Collector Output Capacitance | C _{ob} | V _{CB} =10V, I _E =0, f=1MHz | - | 40 | - | pF | |
| Output Power (Fig.1) | P _o | V _{CC} =12V, P _i =0.3W, f=27MHz | 4 | - | - | W | |

Fig.1 P. TEST CIRCUIT

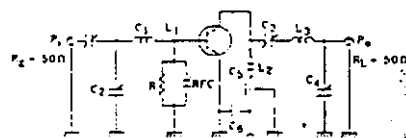

- C₁: ~100pF, C₂, C₃: ~150pF, C₄: ~300pF, C₅: 1000pF
- C₆: 0.01μF, R: 250 Ω
- L₁: 0.8mm φ UEW, 7T, 8mm I.D, L₂: 0.8mm φ UEW, 5T, 8mm I.D
- L₃: 0.8mm φ UEW, 10T, 8mm I.D, RFC: 0.35mm φ UEW, 17T, 5mm I.D

B TRANSCEIVER TX FINAL AMPLIFIER APPLICATION.
F TRANSCEIVER APPLICATION.

FEATURES

- Recommended for Output Stage Application of AM 4W Transmitter.
- High Power Gain.
- Wide Area of Safe Operation.

MAXIMUM RATINGS (Ta=25°C)

| CHARACTERISTIC | SYMBOL | RATING | UNIT |
|--|------------------|-----------|------|
| Collector-Base Voltage | V _{CB0} | 80 | V |
| Collector-Emitter Voltage (R _{BE} =50 Ω) | V _{CEA} | 80 | V |
| Emitter-Base Voltage | V _{EB0} | 4 | V |
| Collector Current | I _C | 4 | A |
| Emitter Current | I _E | -4 | A |
| Collector Power Dissipation (Tc=25°C) | P _C | 10 | W |
| Junction Temperature | T _J | 150 | °C |
| Storage Temperature Range | T _{stg} | -55 ~ 150 | °C |

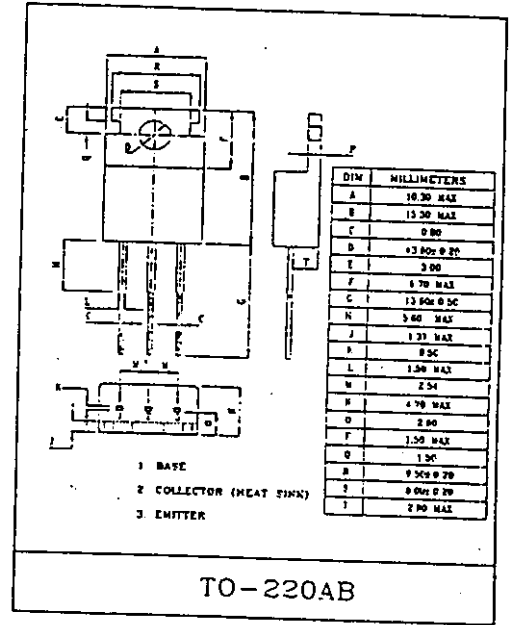

ELECTRICAL CHARACTERISTICS (Ta=25°C)

| CHARACTERISTIC | SYMBOL | TEST CONDITION | MIN. | TYP. | MAX. | UNIT |
|--------------------------------------|----------------------|---|------|------|------|------|
| Collector Cut-off Current | I _{CB0} | V _{CB} =30V, I _E =0 | - | - | 10 | μA |
| Collector-Emitter Voltage | V _{(BR)CEA} | I _C =10mA, R _{BE} =50 Ω | 80 | - | - | V |
| | V _{(BR)EBO} | I _E =1.0mA, I _C =0 | 4 | - | - | V |
| Current Gain | h _{FE} | V _{CE} =5V, I _C =0.5A | 100 | - | 200 | |
| Collector-Emitter Saturation Voltage | V _{CE(sat)} | I _C =3A, I _B =0.3A | - | - | 1.5 | V |
| Transition Frequency | f _T | V _{CE} =5V, I _C =500mA | 100 | - | - | MHz |
| Collector Output Capacitance | C _{ob} | V _{CB} =10V, I _E =0, f=1MHz | - | 40 | - | pF |
| Output Power (Fig.1) | P _o | V _{CC} =12V, P _i =0.3W, f=27MHz | 4 | - | - | W |

FIG. 1 P_o TEST CIRCUIT

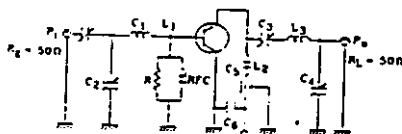

C₁: ~100pF, C₂, C₃: ~150pF, C₄: ~300pF, C₅: 1000pF
 C₆: 0.01μF, R: 250 Ω
 L₁: 0.8mm φ UEW, 7T, 8mm I.D. L₂: 0.8mm φ UEW, 5T, 8mm I.D.
 L₃: 0.8mm φ UEW, 10T, 8mm I.D. RFC: 0.35mm φ UEW, 17T, 5mm I.D.

Fig. 2 27MHz 4W OUTPUT AM TRANSCIVER CIRCUIT

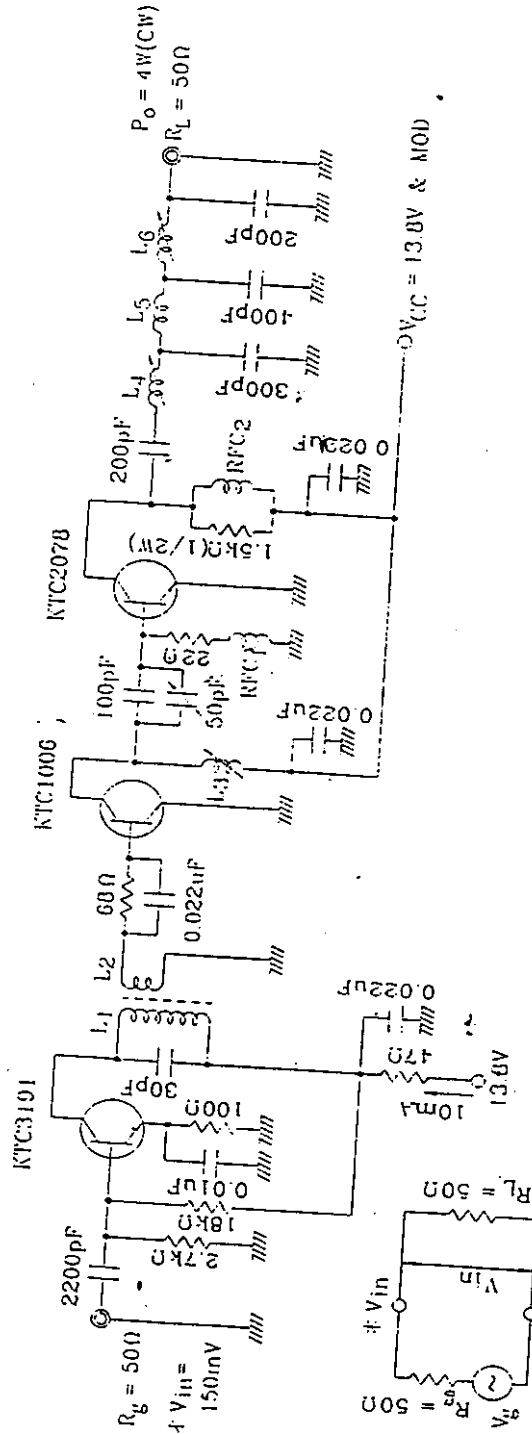

- L1 : 4mm ϕ BOBBIN WITH FERRITE CORE, 0.08mm ϕ UEW, 8 TURNS
- L2 : 4mm ϕ BOBBIN WITH FERRITE CORE, 0.08mm ϕ UEW, 2 TURNS
- L3, L6 : 6.5mm ϕ BOBBIN WITH FERRITE CORE, 0.6mm ϕ UEW, 2 TURNS
- L4 : 6.5mm ϕ BOBBIN WITH FERRITE CORE, 0.6mm ϕ Sn PLATED COPPER WIRE 6 $\frac{1}{2}$ TURNS
- L5 : 6.5mm ϕ BOBBIN WITH FERRITE CORE, 0.6mm ϕ Sn PLATED COPPER WIRE 8 $\frac{1}{2}$ TURNS
- RFC1 : 1.7uH, 7BA-100K (TOKO)
- RFC2 : 0.2mm ϕ UEW, 30 TURNS

RESISTOR : 1/4W CARBON
CAPACITOR : CERAMIC

KTC2078

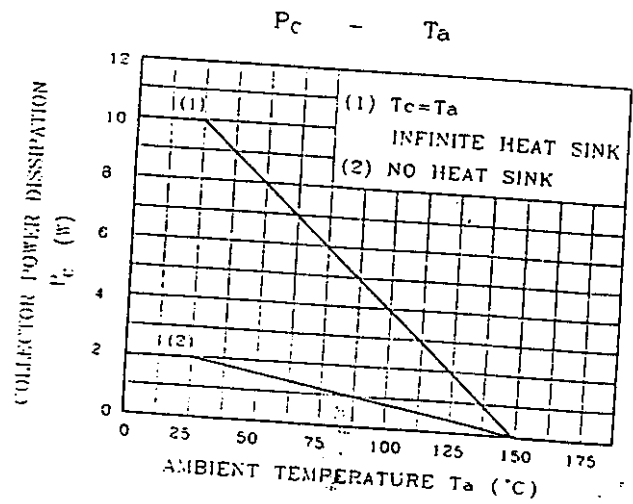
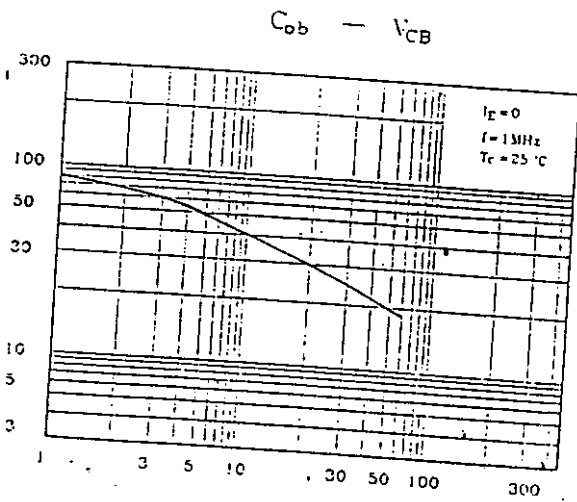
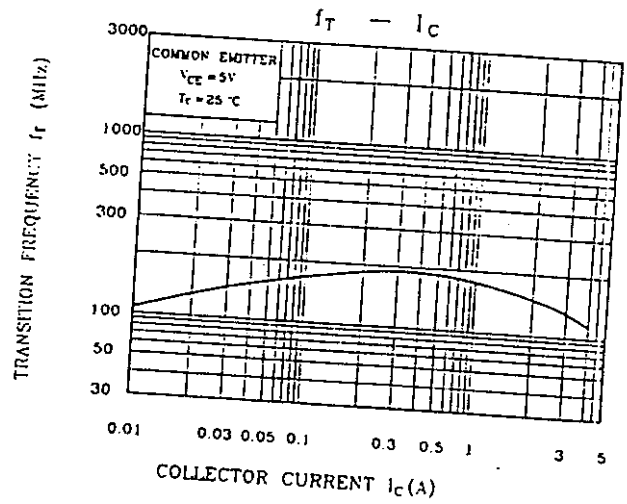
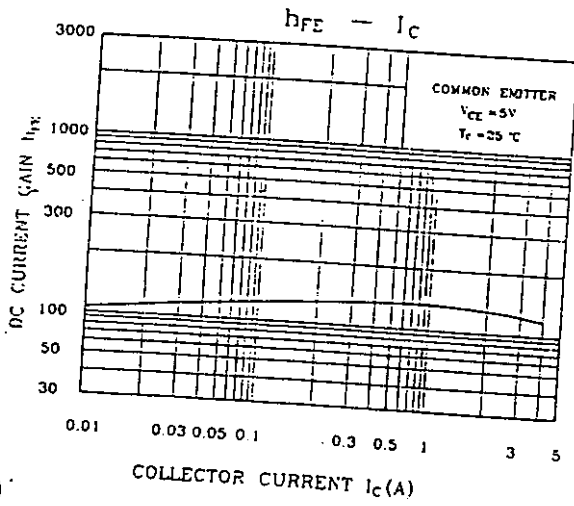
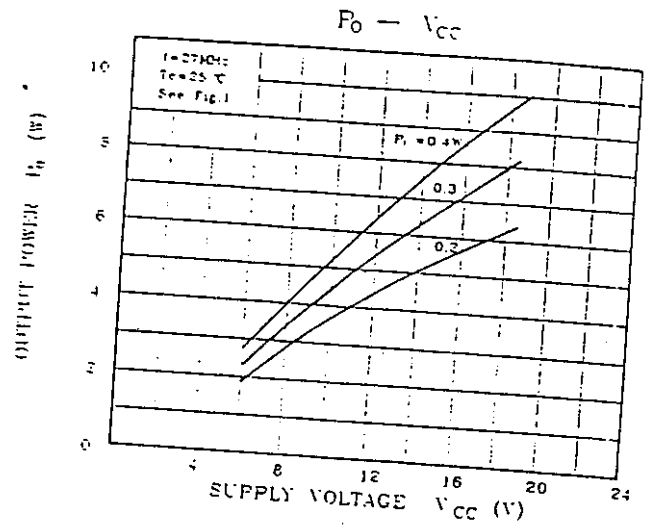
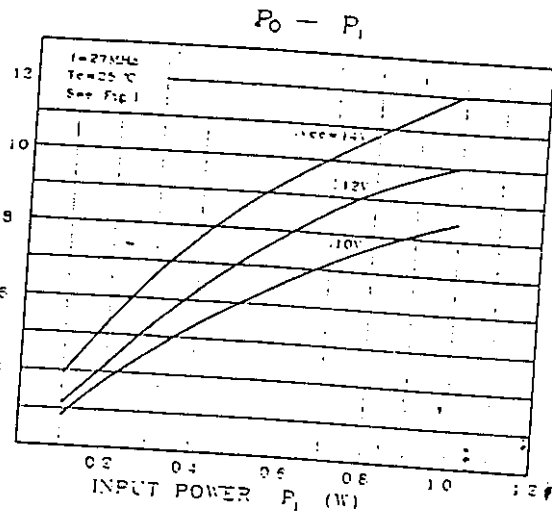

APPENDIX 3
FUNCTION OF DEVICES
HH28

ONE (1) PAGE LIST OF ACTIVE SEMICONDUCTORS
AND FUNCTIONS FOLLOW THIS SHEET

FUNCTION OF DEVICES
FCC ID: BBOHH28

APPENDIX 3

C . SEMICONDUCTORS AND FUNCTION

| REF. NO | DESCRIPTION | RX | TX | REMARK |
|---------|-------------|-----------------|-----------------|----------|
| Q101 | KTC3875S | RF ATTENUATOR | × | KEC |
| Q102 | KTC3880S | RF AMP | × | KEC |
| Q103 | KTC3880S | 1 'ST MIXER | × | KEC |
| Q201 | KTC3880S | 2 'ND MIXER | × | KEC |
| Q202 | KTC3880S | IF AMP | × | KEC |
| Q203 | KTC3880S | IF AMP | × | KEC |
| Q204 | KTA1504S | A.N.L. | × | KEC |
| Q403 | KTA1504S | × | A. L. C. | KEC |
| Q404 | KTC3875S | × | A. L. C. | KEC |
| Q500 | KTC3875S | LED CONTROL | LED CONTROL | KEC |
| Q501 | KTA1504S | LED CONTROL | LED CONTROL | KEC |
| Q502 | KTA1504S | LED CONTROL | LED CONTROL | KEC |
| Q503 | KTA1504S | LED CONTROL | LED CONTROL | KEC |
| Q510 | KTC3875S | CHARGE PUMP | CHARGE PUMP | KEC |
| Q511 | KTC3875S | CHARGE PUMP | CHARGE PUMP | KEC |
| Q513 | KRC110S | SQ CONTROL | X | KEC |
| Q550 | KTC3875S | SQ CONTROL | × | KEC |
| Q553 | KTA1504 | SQ CONTROL | × | KEC |
| Q601 | KTC3880S | BUFFER | BUFFER | KEC |
| Q602 | KTC3875S | × | SWITCHING | KEC |
| Q603 | KTC3880S | VCO | VCO | KEC |
| Q701 | KTC3880S | × | DOUBLER | KEC |
| Q702 | KTC3880S | × | PRE AMP | KEC |
| Q703 | KTC1006 | × | RF DRIVER | KEC |
| Q704 | KTC2078 | × | RF POWER AMP | KEC |
| Q900 | KTC3875S | BATT LOW | BATT LOW | KEC |
| Q901 | KTC3875S | BATT LOW | BATT LOW | KEC |
| Q902 | KTC3875S | REGULATOR(9.1V) | REGULATOR(9.1V) | KEC |
| Q903 | KRA102S | B+ CONTROL | × | KEC |
| Q904 | KRA102S | × | B+ CONTROL | KEC |
| IC401 | KIA7217AP | × | AF AMP | KEC |
| IC501 | LC7185 | PLL | PLL | SANYO |
| IC551 | LM386 | AF AMP | × | NATIONAL |

*** MANUFACTURER INFORMATION ***

- * K.E.C ----- KOREA ELECTRONICS SEMICONDUCTOR CO., LTD.
- * SANYO ----- JAPAN SANYO SEMICONDUCTOR CO., LTD.
- * NATIONAL ----- NATIONAL SEMICONDUCTOR CO., LTD.

APPENDIX 4
SCHEMATIC DIAGRAM

ONE (1) SCHEMATIC DIAGRAM FOLLOWS THIS SHEET

SCHEMATIC DIAGRAM
FCC ID: BBOHH28

APPENDIX 4

TABLE 1
 TRANSMITTER CONDUCTED SPURIOUS

| <u>Channel</u> | <u>Spurious Frequency</u> <u>MHz</u> | <u>dB Below Unmod</u> <u>Carrier Ref.</u> | |
|----------------|---|--|-------------|
| | | <u>Low</u> | <u>High</u> |
| 1 | 53.930 | 86 | 83 |
| 1 | 80.895 | 75 | 82 |
| 1 | 107.860 | 88 | 89 |
| 1 | 134.825 | 95 | 93 |
| 1 | 161.790 | 96 | 96 |
| 1 | 188.755 | 95 | 95 |
| 1 | 215.720 | 93 | 94 |
| 1 | 242.685 | 94 | 93 |
| 1 | 269.650 | 91 | 94 |
| 21 | 54.430 | 89 | 86 |
| 21 | 81.645 | 76 | 85 |
| 21 | 108.860 | 90 | 93 |
| 21 | 136.075 | 95 | 92 |
| 21 | 163.290 | 94 | 93 |
| 21 | 190.505 | 93 | 93 |
| 21 | 217.720 | 95 | 95 |
| 21 | 244.935 | 95 | 94 |
| 21 | 272.150 | 93 | 94 |
| 40 | 54.810 | 91 | 91 |
| 40 | 82.215 | 76 | 86 |
| 40 | 109.620 | 89 | 90 |
| 40 | 137.025 | 92 | 92 |
| 40 | 164.430 | 96 | 95 |
| 40 | 191.835 | 96 | 93 |
| 40 | 219.240 | 96 | 94 |
| 40 | 246.645 | 92 | 96 |
| 40 | 274.050 | 94 | 91 |
| | Required: | 60 | 60 |

All other spurious were more than 20 dB below required 60 dB suppression.

E. FIELD STRENGTH MEASUREMENTS OF SPURIOUS RADIATION
(Paragraph 2.993(a)(b,2) of the Rules)

Field intensity measurements of radiated spurious emissions from the HH28 transmitter were made with a Tektronix 494P spectrum analyzer and dummy load located in an open field 3 meters from the test antenna. Output power was 3.5 watts. The supply voltage was 13.8 volts. The transmitter and test antennae were arranged according to OCE 42 to maximize pickup. No external accessory jacks are provided. Both vertical and horizontal test antenna polarization were employed.

Measurements were made from 10 MHz to 10 times the maximum operating frequency of 26.965 or 269.650 MHz.

Reference level for the spurious radiations was taken as an ideal dipole excited by 3.5 watts, the output power of the transmitter according to the following relationship:*

$$E = \frac{(49.2 \times P_t)^{1/2}}{R}$$

where E = electric-field intensity in volts/meter
 P_t = transmitter power in watts
 R = distance in meters

for this case $E = \frac{(49.2 \times 3.5)^{1/2}}{3} = 4.4 \text{ V/m}$

Since the spectrum analyzer is calibrated in decibels above one milliwatt (dBm):

$$\begin{aligned} 4.2 \text{ volts/meter} &= 4.2 \times 10^6 \text{ uV/m} \\ \text{dBu/m} &= 20 \text{ Log}_{10}(4.2 \times 10^6) \\ &= 133 \text{ dBu/m} \end{aligned}$$

Since 1 uV/m = -107 dBm, the reference becomes

$$133 - 107 = 26 \text{ dBm}$$

Representing a conversion for convenience, from dBu to dBm. The measurement system was capable of detecting signals 100 dB or more below the carrier reference level. Data, including antenna factor and line loss corrections, are shown in Table 2.

*Reference Data for Radio Engineers, International Telephone and Telegraph Corporation, Sixth Edition.

F. FIELD STRENGTH MEASUREMENTS (Continued)

TABLE 2
 TRANSMITTER CABINET RADIATED SPURIOUS
 Channel 1, 26.965 MHz; 3.5 watts, 13.8 Vdc
dB Below Carrier Reference

| <u>Frequency, MHz</u> | (V) | (H) |
|-----------------------|-----|-----|
| 53.930 | 81 | 91 |
| 80.895 | 102 | 102 |
| 107.860 | 100 | 89 |
| 134.825 | 91 | 89 |
| 161.790 | 84 | 81 |
| 188.755 | 95 | 91 |
| 215.720 | 98 | 95 |
| 242.685 | 95 | 94 |
| 269.650 | 93 | 94 |
| Required: | 60 | 60 |

Any unlisted spurious were more than 80 below carrier reference from 4.5 to 269.65 MHz.

F. FREQUENCY STABILITY
 (Paragraph 2.995(a)(1) of the Rules)

Measurement of frequency stability versus temperature was made at temperatures from -30°C to $+50^{\circ}\text{C}$ in 10° increments. At each temperature, the unit was exposed to the test chamber ambient a minimum of 60 minutes after indicated chamber temperature ambient had stabilized to within $\pm 2^{\circ}$ of the desired test temperature. Following a 30 minute soak at each temperature, the unit was turned on, keyed and frequency measured within 2 minutes. Test temperature was sequenced in the order shown in Table 3, starting with -30°C .

A Thermotron S1.2 temperature chamber was used. The transmitter output stage was terminated in a dummy load. Primary supply was 13.8 volts. Frequency was measured with a HP 5385A digital frequency counter connected to the transmitter through a power attenuator. Measurements were made on Channel 9, 27.065 MHz. No transient keying effects were observed.

G. FREQUENCY STABILITY (Continued)

TABLE 3

| <u>Temperature</u> | <u>Output Frequency, MHz</u> |
|--------------------------|------------------------------|
| -29.0 | 27.064770 |
| -19.8 | 27.064931 |
| - 9.4 | 27.065018 |
| 0.1 | 27.065059 |
| 9.9 | 27.065061 |
| 20.4 | 27.065035 |
| 30.5 | 27.065008 |
| 40.3 | 27.065007 |
| 50.0 | 27.065050 |
| Maximum frequency error: | 27.065000 |
| | <u>27.064770</u> |
| | - .000230 MHz |

FCC Rule 95.625(b) specifies .005% or a maximum of $\pm .001353$ MHz.

G. FREQUENCY STABILITY AS A FUNCTION OF SUPPLY VOLTAGE
(Paragraph 2.995(d)(2) of the Rules)

Oscillator frequency as a function of power supply voltage was measured with a HP 5385A digital frequency counter as supply voltage provided by an HP 6264B variable dc power supply was varied $\pm 15\%$ from the nominal 13.8 volt rating. A Keithley 197 digital voltmeter was used to measure supply voltage at transmitter primary input terminals. Measurements were made at 20°C ambient.

TABLE 4

| <u>Supply Voltage</u> | <u>Output Frequency, MHz</u> |
|---------------------------------|------------------------------|
| 15.87 | 27.065036 |
| 15.19 | 27.065037 |
| 14.49 | 27.065034 |
| 13.80 | 27.065035 |
| 13.11 | 27.065037 |
| 12.42 | 27.065036 |
| 11.73 | 27.065039 |
| 11.04 (rated battery end-point) | 27.065037 |
| Maximum frequency error: | 27.065000 |
| | <u>27.065037</u> |
| | + .000037 MHz |

FCC Rule 95.625(b) specifies .005% or a maximum of $\pm .001353$ MHz. No effects on frequency related to keying the unit were observed.

H. ADDITIONAL REQUIREMENTS FOR TYPE ACCEPTANCE
(Paragraph 95.669 of the Rules)

The HH28 meets the applicable provision of 95.669(a).

External controls are limited to the following per 95.669(a):

1. Primary power connection
2. Microphone
3. RF output power connection
4. Not applicable, no accessory jacks
5. On-off switch (combined with receiver volume control)
6. Not applicable, AM only
7. Not applicable, AM only
8. Transmitting frequency selector
9. Transmit-receive switch
10. See #1
11. Not applicable

The serial number of each unit will be implemented in accordance with 95.671.

A copy of Part 95, Subpart D, of the FCC rules for the Citizens Band Radio Service, current at the time of packing of the transmitter, must be furnished with each CB transmitter marketed per 95.673.

I. PLL RESTRICTIONS
(Per Public Notice of April 27, 1978)

The HH28 meets the following conditions specified in the April 27, 1978 notice:

1. All frequency-determining elements, including crystals, PLL integrated circuits and channel selector switches are permanently wired and soldered in place.
2. The PLL integrated circuit division ratio selection is BCD coded. All the 40 channels are mask programmed into the CPU and can not be changed.
3. Channel selection is controlled by the masked program of the CPU and has only 40 positions for use in the US.
4. All the undedicated leads in the CPU and P11 integrated circuits are disabled and not serviceable by the user.

J. FINAL AMPLIFIER DATA

1. A copy of the final RF amplifier data sheet is included in Appendix 10.

FIGURE 1
TRANSMITTER FREQUENCY RESPONSE

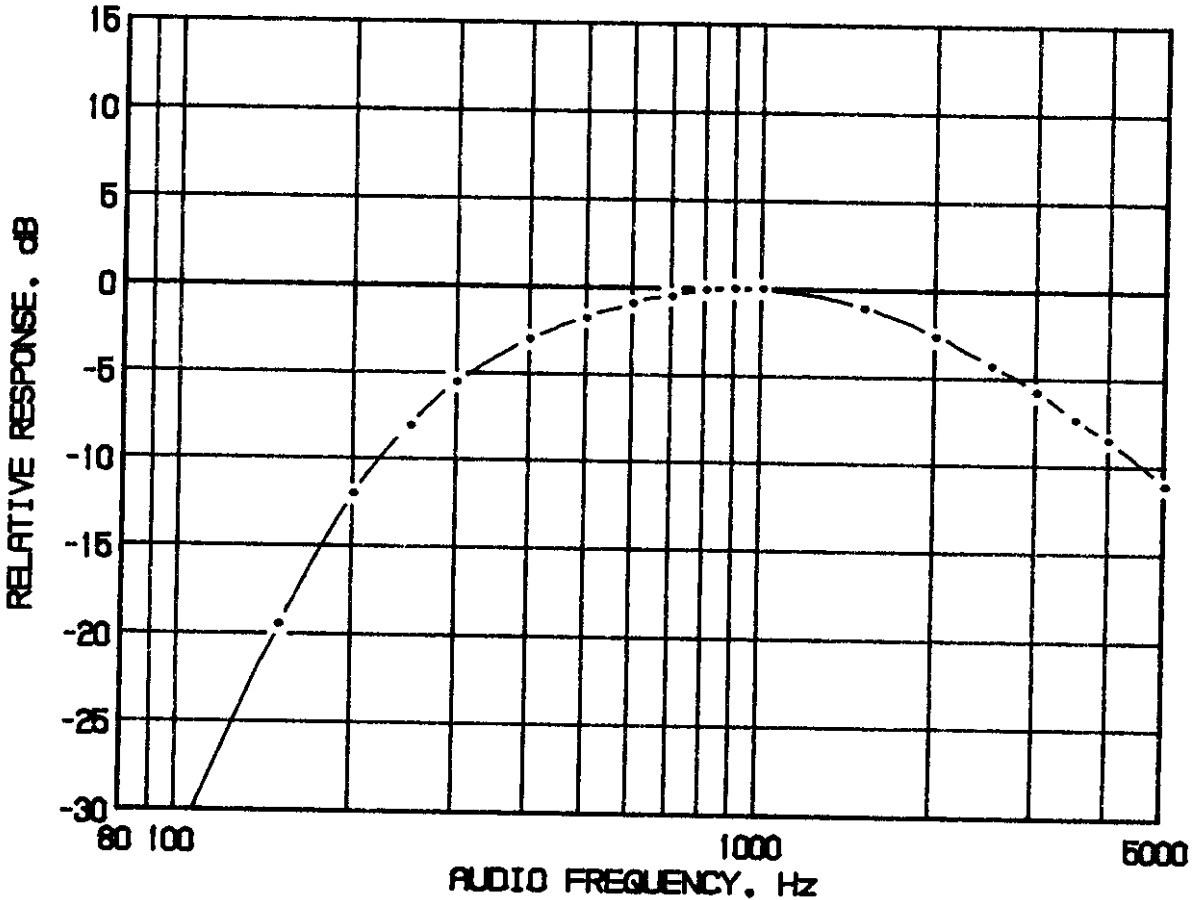

TRANSMITTER FREQUENCY RESPONSE
FCC ID: BBOHH28

FIGURE 1

FIGURE 2a

AM MODULATION LIMITING - POSITIVE PEAKS

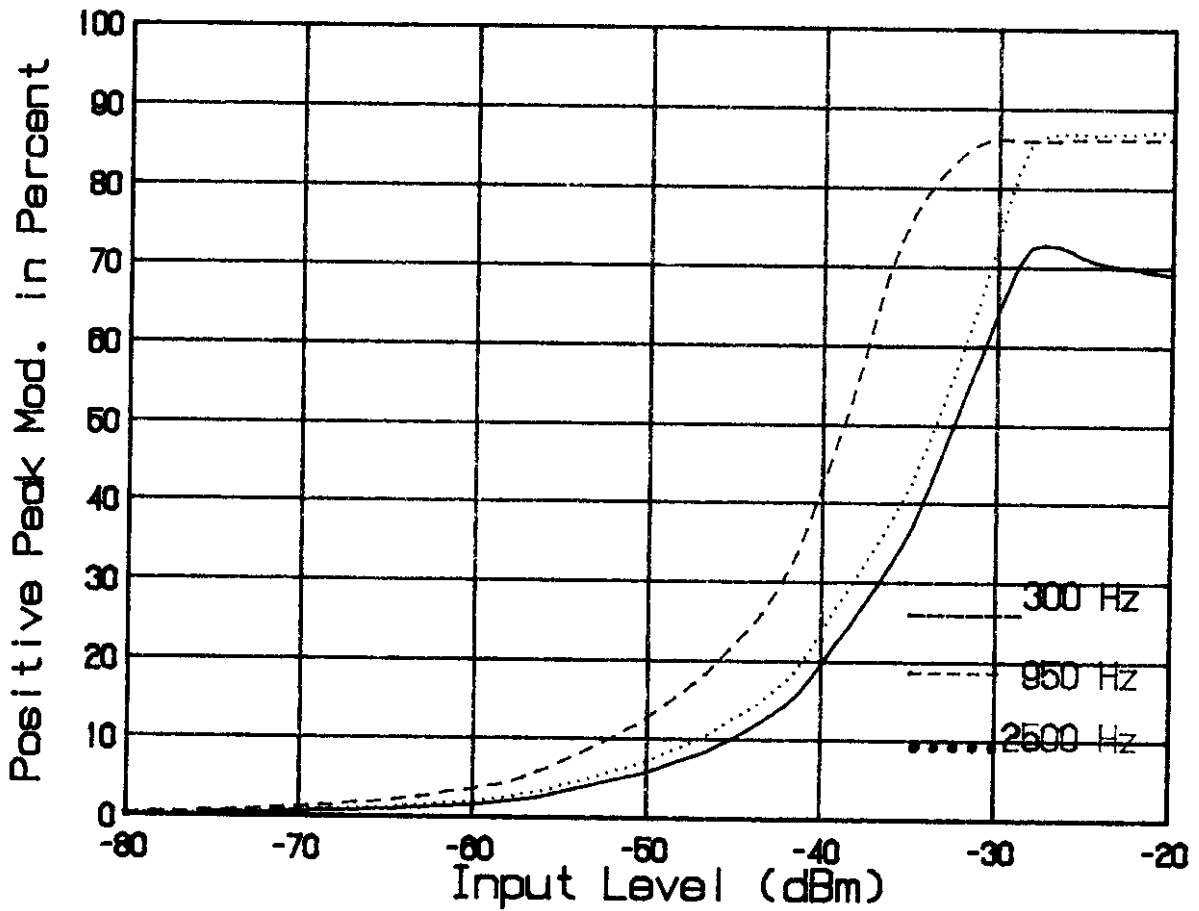

MODULATION LIMITING CHARACTERISTICS

Percent modulation as a function of input level at microphone jack in dBm for 300 Hz, 950 Hz, and 2500 Hz tones.

MODULATION LIMITING POSITIVE PEAKS

FCC ID: BBOHH28

FIGURE 2a

FIGURE 2b

AM MODULATION LIMITING - NEGATIVE PEAKS

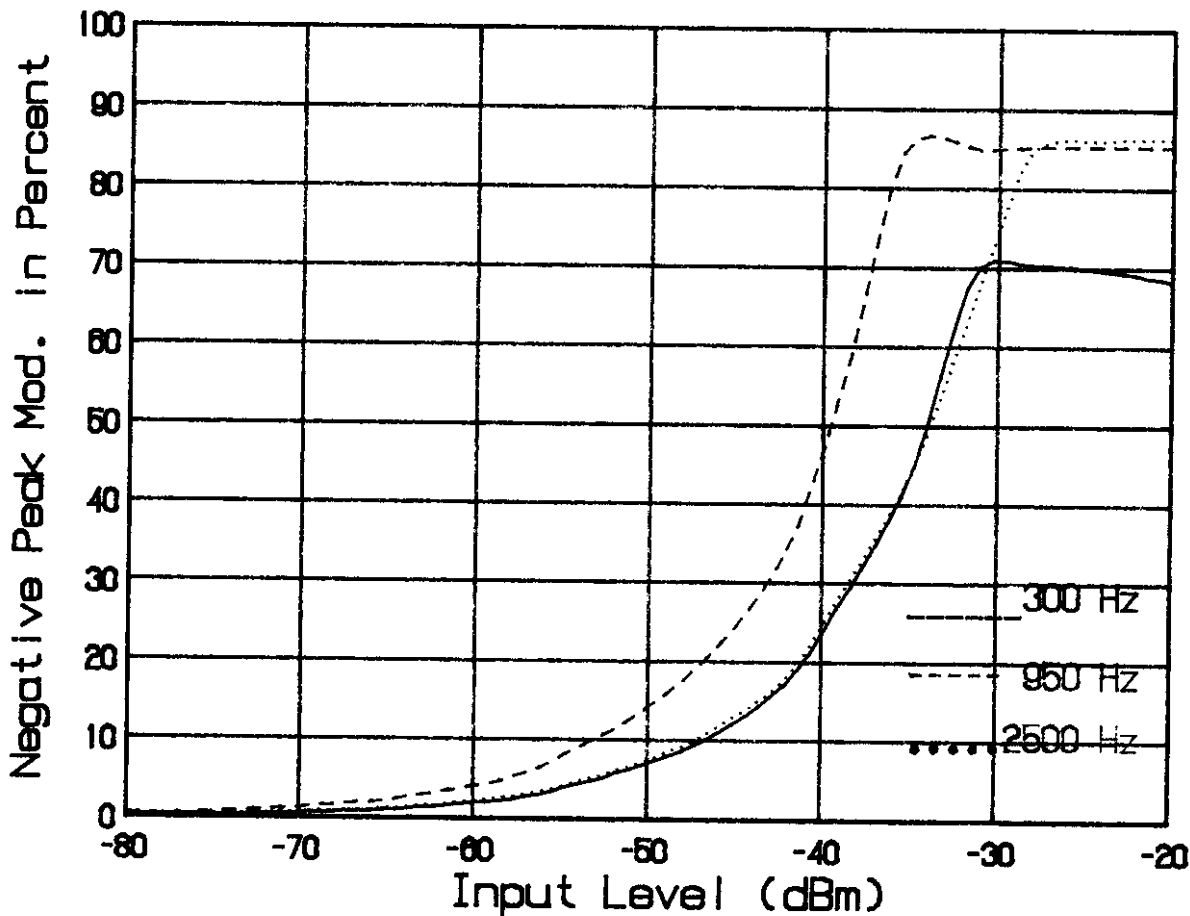

MODULATION LIMITING CHARACTERISTICS

Percent modulation as a function of input level at microphone jack in dBm for 300 Hz, 950 Hz, and 2500 Hz tones.

MODULATION LIMITING NEGATIVE PEAKS

FCC ID: BBOHH28

FIGURE 2b

FIGURE 3a

MODULATION LIMITER ATTACK TIME

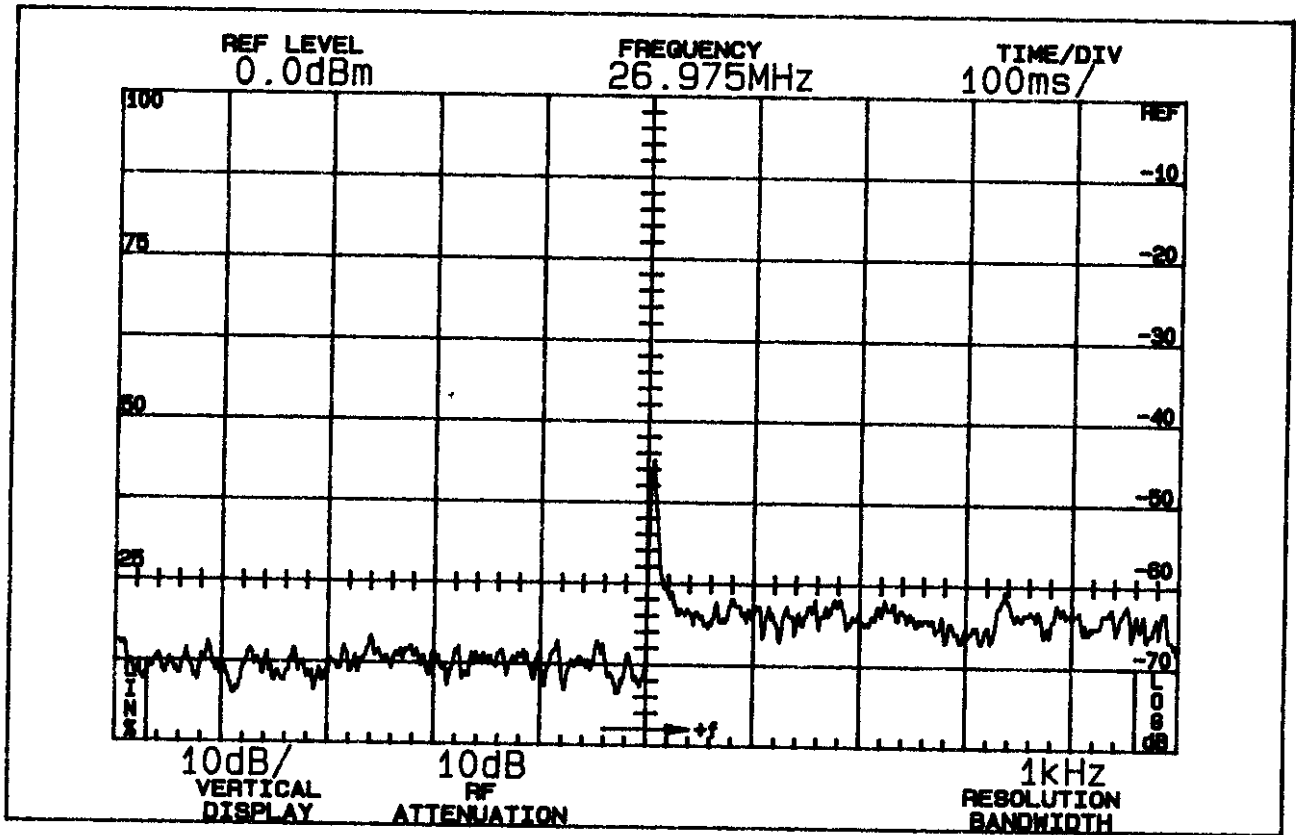

Measurement Conditions: 16 dB over 50% modulation level at 950 Hz with 2500 Hz tone, upper fourth order sideband; horizontal scale 100 ms/div.

UPPER FOURTH-ORDER SIDEBAND
LIMITER ATTACK TIME
FCC ID: BBOHH28

FIGURE 3a

FIGURE 3b

MODULATION LIMITER ATTACK TIME

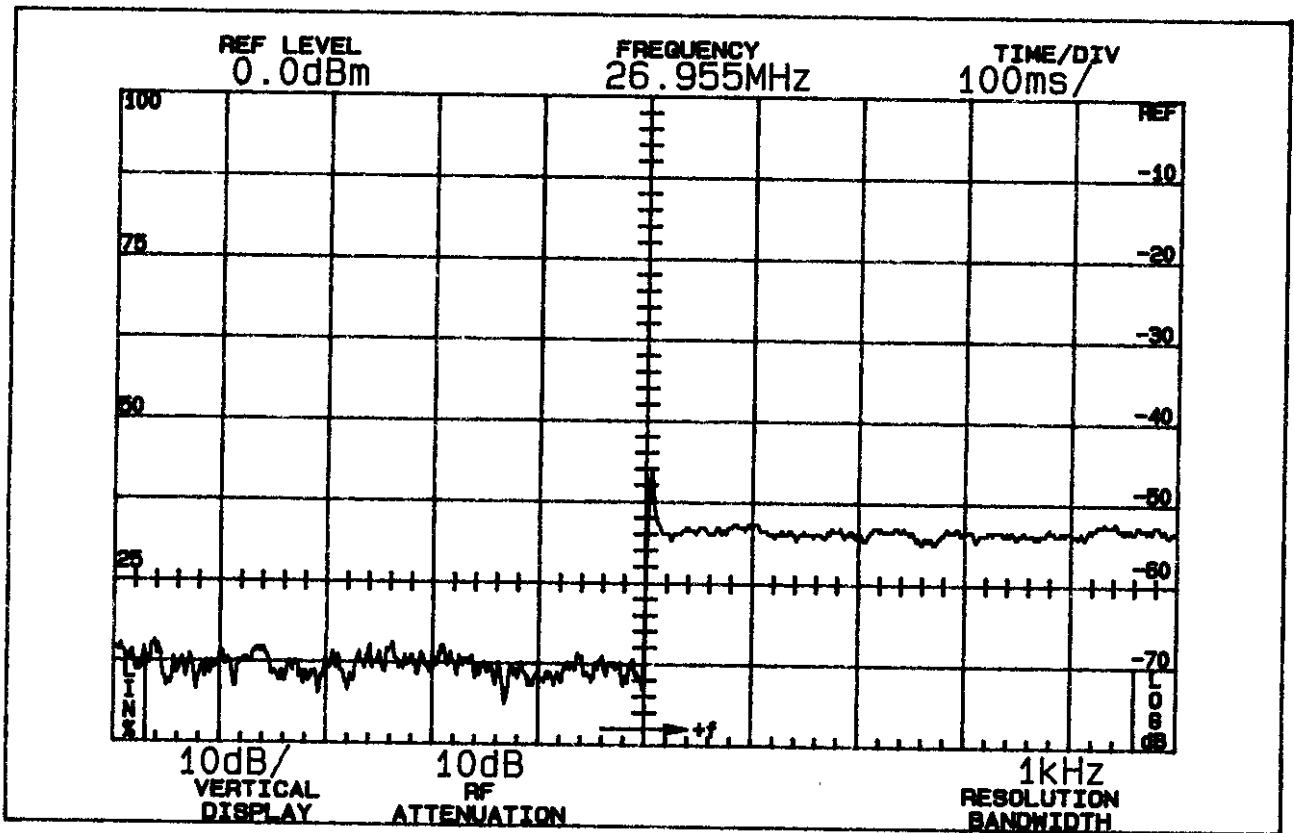

Measurement Conditions: 16 dB over 50% modulation level at 950 Hz with 2500 Hz tone, lower fourth order sideband; horizontal scale 100 ms/div.

LOWER FOURTH-ORDER SIDEBAND
LIMITER ATTACK TIME
FCC ID: BBOHH28

FIGURE 3b

C. MODULATION CHARACTERISTICS (Continued)

4. Occupied Bandwidth - AM
(Paragraph 2.989(c) of the Rules)

Figures 4a and 4b are plots of the sideband envelope of the transmitter at low and high power settings respectively taken from a Tektronix 494P spectrum analyzer. Modulation corresponded to conditions of 2.989(a) and consisted of 2500 Hz tone at an input level 16 dB greater than that necessary to produce 50% modulation at 950 Hz, the frequency of maximum response. Measured modulation under these conditions was 95%.

The plots are within the limits imposed by Paragraph 95.631(b)(1,3) for double sideband AM modulation. The horizontal scale, frequency, is 10 kHz per division and the vertical scale, amplitude, is a logarithmic presentation equal to 10 dB per division.

NOTE: Reference of 0 dBc is unmodulated transmitter power.

FIGURE 4a
OCCUPIED BANDWIDTH

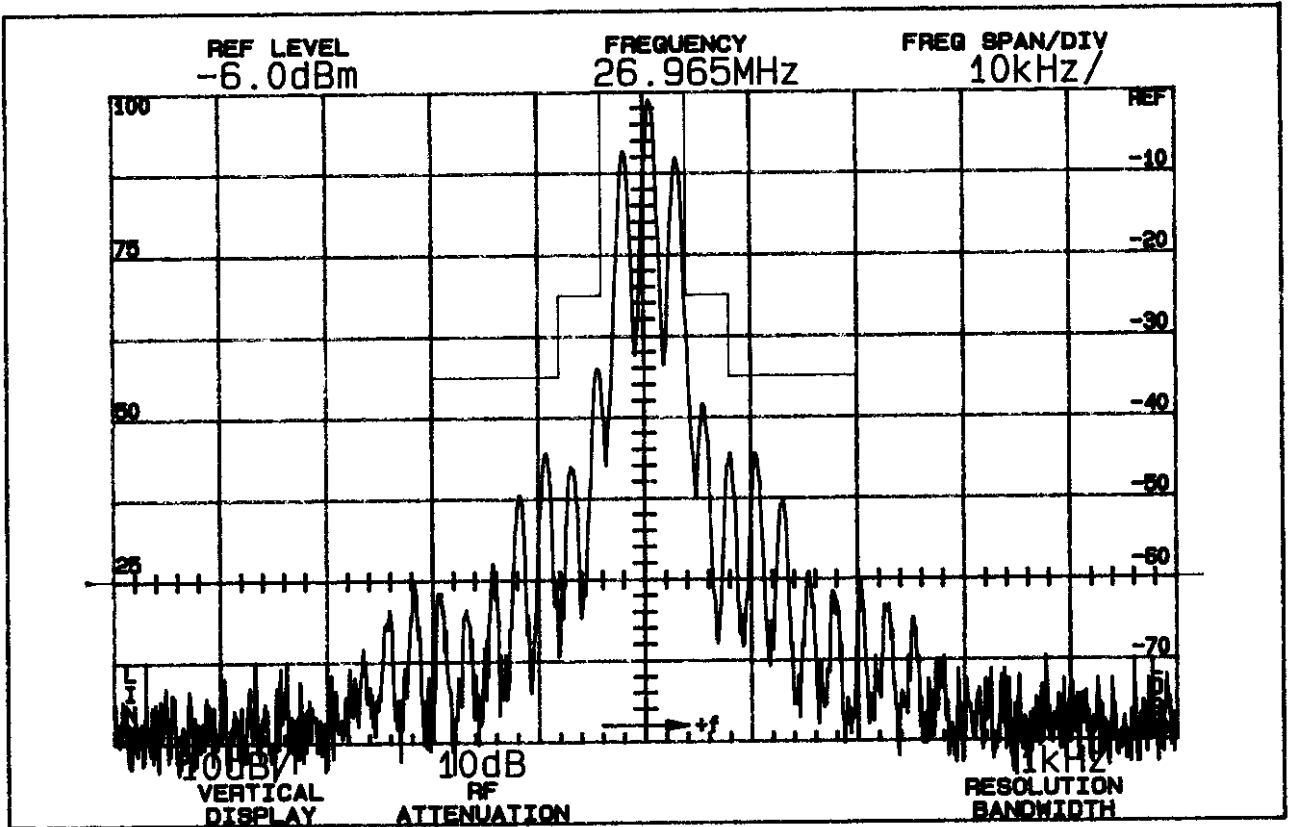

ATTENUATION IN dB BELOW
MEAN OUTPUT POWER
Required

On any frequency more than 50%
up to and including 100% of the
authorized bandwidth, 8kHz (4-8kHz)

25

On any frequency more than 100%,
up to and including 250% of the
authorized bandwidth (8-20kHz)

35

On any frequency removed from the
assigned frequency by more than
250% of the authorized bandwidth

60

OCCUPIED BANDWIDTH
FCC ID: BBOHH28

FIGURE 4a (Low Power)

FIGURE 4b
OCCUPIED BANDWIDTH

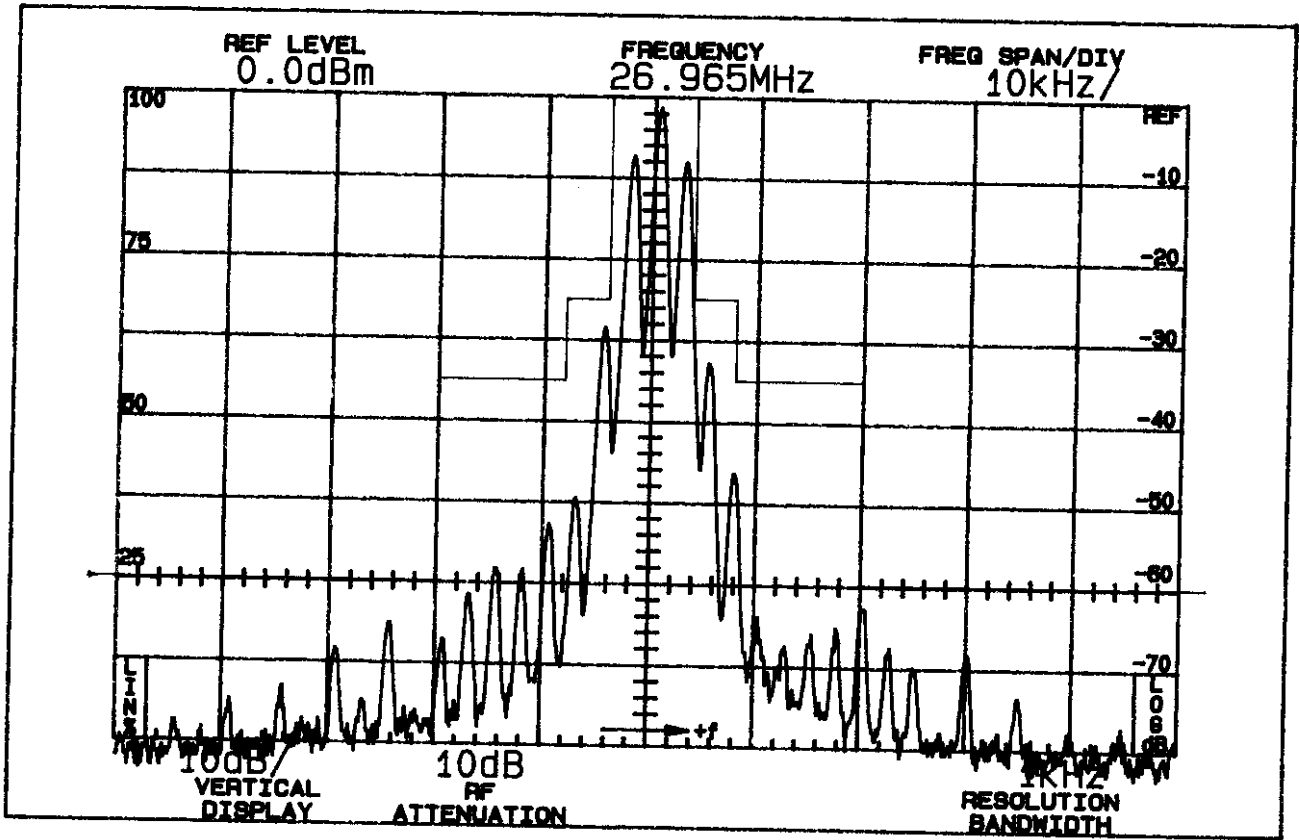

ATTENUATION IN dB BELOW
MEAN OUTPUT POWER
Required

On any frequency more than 50%
up to and including 100% of the
authorized bandwidth, 8kHz (4-8kHz)

25

On any frequency more than 100%,
up to and including 250% of the
authorized bandwidth (8-20kHz)

35

On any frequency removed from the
assigned frequency by more than
250% of the authorized bandwidth

60

OCCUPIED BANDWIDTH
FCC ID: BBOHH28

FIGURE 4b (High Power)

D. SPURIOUS EMISSIONS AT THE ANTENNA TERMINALS
(Paragraph 2.991 of the Rules)

The HH28 transmitter was tested in the AM mode for spurious emissions at the antenna terminals while the equipment was modulated with a 2500 Hz signal, 16 dB above minimum input signal for 50% modulation at 950 Hz, the frequency of highest sensitivity.

Measurements were made with Tektronix 494P spectrum analyzer coupled to the transmitter output terminal through Narda 765-20 50 ohm power attenuator.

In order to improve measurement system dynamic range, a series trap tuned to the carrier frequency was used on the Narda attenuator output. The trap, which had negligible shunt attenuation at the second harmonic and high frequencies, provided 26 dB attenuation of the fundamental. The trap was not used during close-in (within 10 MHz of the carrier) spurious measurements.

During the tests, the transmitter was terminated in the Narda 765-20 dummy load. Power was monitored on a Bird 43 Thru-Line wattmeter; dc supply was 13.8 volts throughout the tests.

Spurious emission was measured at both power settings on Channels 1, 21, and 40 throughout the RF spectrum from 10 to 300 MHz. Any emissions that were between the 60 dB attenuation required and the 100 dB noise floor of the spectrum analyzer were recorded. Data are shown in Table 1.