

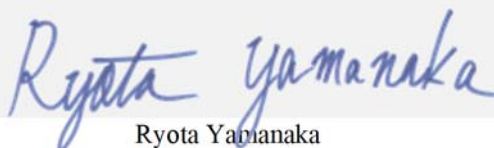



RADIO TEST REPORT

Test Report No.: 14483763H-C-R2

Customer	DENSO TEN Limited
Description of EUT	Car Audio
Model Number of EUT	TN0040A
FCC ID	BABTN0040A
Test Regulation	FCC Part 15 Subpart E
Test Result	Complied (Refer to SECTION 3)
Issue Date	July 18, 2023
Remarks	-

Representative Test Engineer	Approved By
 Junya Okuno Engineer	 Ryota Yamanaka Engineer
 	
CERTIFICATE 5107.02	
<input type="checkbox"/> The testing in which "Non-accreditation" is displayed is outside the accreditation scopes in UL Japan, Inc.	
<input checked="" type="checkbox"/> There is no testing item of "Non-accreditation".	

Report Cover Page - Form-ULID-003532 (DCS:13-EM-F0429) Issue# 21.0

ANNOUNCEMENT

- This test report shall not be reproduced in full or partial, without the written approval of UL Japan, Inc.
- The results in this report apply only to the sample tested. (Laboratory was not involved in sampling.)
- This sample tested is in compliance with the limits of the above regulation.
- The test results in this test report are traceable to the national or international standards.
- This test report must not be used by the customer to claim product certification, approval, or endorsement by the A2LA accreditation body.
- This test report covers Radio technical requirements.
It does not cover administrative issues such as Manual or non-Radio test related Requirements. (if applicable)
- The all test items in this test report are conducted by UL Japan, Inc. Ise EMC Lab.
- The opinions and the interpretations to the result of the description in this report are outside scopes where UL Japan, Inc. has been accredited.
- The information provided from the customer for this report is identified in Section 1.
- For test report(s) referred in this report, the latest version (including any revisions) is always referred.

REVISION HISTORY

Original Test Report No.: 14483763H-C

This report is a revised version of 14483763H-C-R1. 14483763H-C-R1 is replaced with this report.

Revision	Test Report No.	Date	Page Revised Contents
- (Original)	14483763H-C	November 8, 2022	-
1	14483763H-C-R1	July 4, 2023	Cover page: Deletion of notes for Remarks
1	14483763H-C-R1	July 4, 2023	SECTION 2.1: Addition of Test Date for 99 % Occupied Bandwidth (11n-40: 5190 MHz)
1	14483763H-C-R1	July 4, 2023	SECTION 2.2: Radio Specification from 4.17 dBi to 3.79 dBi (U-NII-1) 3.34 dBi (U-NII-3)
1	14483763H-C-R1	July 4, 2023	SECTION 2.2: Deletion of sentence about simultaneous transmission.
1	14483763H-C-R1	July 4, 2023	SECTION 4.2: Correction of Configuration for Radiated emission test -Correction of DC power from DC 13.2 V to DC 12 V -Deletion of item P to R and Cable 16 to 19
1	14483763H-C-R1	July 4, 2023	SECTION 4.2: Addition of Configuration for Antenna Terminal Conducted test
1	14483763H-C-R1	July 4, 2023	SECTION 6: Correction of RBW of Maximum Power Spectral Density
1	14483763H-C-R1	July 4, 2023	Test data of 99 % Occupied Bandwidth - Correction of test value about 11n-40, 11ac-40 - Replace of waveform about 11n-40, 11ac-40
1	14483763H-C-R1	July 4, 2023	Test data of Maximum Conducted Output Power and Maximum Power Spectral Density Correction of Antenna Gain, and Re-calculation Result and Margin
1	14483763H-C-R1	July 4, 2023	Test data of Conducted Spurious Emission - Deletion of "*" from Antenna Gain cell - Re-calculation of test data
1	14483763H-C-R1	July 4, 2023	Test Instruments Addition of Test Equipment for 99 % Occupied Bandwidth
2	14483763H-C-R2	July 18, 2023	Cover page and SECTION 1: Correction of Company Name from "Denso TEN Limited" to "DENSO TEN Limited"
2	14483763H-C-R2	July 18, 2023	APPENDIX 2: Addition of Test Equipment: Local ID MOS-28, MMM-17 and MAT-89

Reference: Abbreviations (Including words undescribed in this report)

A2LA	The American Association for Laboratory Accreditation	ICES	Interference-Causing Equipment Standard
AC	Alternating Current	IEC	International Electrotechnical Commission
AFH	Adaptive Frequency Hopping	IEEE	Institute of Electrical and Electronics Engineers
AM	Amplitude Modulation	IF	Intermediate Frequency
Amp, AMP	Amplifier	ILAC	International Laboratory Accreditation Conference
ANSI	American National Standards Institute	ISED	Innovation, Science and Economic Development Canada
Ant, ANT	Antenna	ISO	International Organization for Standardization
AP	Access Point	JAB	Japan Accreditation Board
ASK	Amplitude Shift Keying	LAN	Local Area Network
Atten., ATT	Attenuator	LIMS	Laboratory Information Management System
AV	Average	MCS	Modulation and Coding Scheme
BPSK	Binary Phase-Shift Keying	MRA	Mutual Recognition Arrangement
BR	Bluetooth Basic Rate	N/A	Not Applicable
BT	Bluetooth	NIST	National Institute of Standards and Technology
BT LE	Bluetooth Low Energy	NS	No signal detect.
BW	BandWidth	NSA	Normalized Site Attenuation
Cal Int	Calibration Interval	NVLAP	National Voluntary Laboratory Accreditation Program
CCK	Complementary Code Keying	OBW	Occupied Band Width
Ch., CH	Channel	OFDM	Orthogonal Frequency Division Multiplexing
CISPR	Comité International Special des Perturbations Radioelectriques	P/M	Power meter
CW	Continuous Wave	PCB	Printed Circuit Board
DBPSK	Differential BPSK	PER	Packet Error Rate
DC	Direct Current	PHY	Physical Layer
D-factor	Distance factor	PK	Peak
DFS	Dynamic Frequency Selection	PN	Pseudo random Noise
DQPSK	Differential QPSK	PRBS	Pseudo-Random Bit Sequence
DSSS	Direct Sequence Spread Spectrum	PSD	Power Spectral Density
EDR	Enhanced Data Rate	QAM	Quadrature Amplitude Modulation
EIRP, e.i.r.p.	Equivalent Isotropically Radiated Power	QP	Quasi-Peak
EMC	ElectroMagnetic Compatibility	QPSK	Quadri-Phase Shift Keying
EMI	ElectroMagnetic Interference	RBW	Resolution Band Width
EN	European Norm	RDS	Radio Data System
ERP, e.r.p.	Effective Radiated Power	RE	Radio Equipment
EU	European Union	RF	Radio Frequency
EUT	Equipment Under Test	RMS	Root Mean Square
Fac.	Factor	RSS	Radio Standards Specifications
FCC	Federal Communications Commission	Rx	Receiving
FHSS	Frequency Hopping Spread Spectrum	SA, S/A	Spectrum Analyzer
FM	Frequency Modulation	SG	Signal Generator
Freq.	Frequency	SVSWR	Site-Voltage Standing Wave Ratio
FSK	Frequency Shift Keying	TR	Test Receiver
GFSK	Gaussian Frequency-Shift Keying	Tx	Transmitting
GNSS	Global Navigation Satellite System	VBW	Video BandWidth
GPS	Global Positioning System	Vert.	Vertical
Hori.	Horizontal	WLAN	Wireless LAN

CONTENTS	PAGE
SECTION 1: Customer Information	5
SECTION 2: Equipment Under Test (EUT).....	5
SECTION 3: Test specification, Procedures & Results	7
SECTION 4: Operation of EUT during testing.....	10
SECTION 5: Radiated Spurious Emission and Band Edge Compliance.....	14
SECTION 6: Antenna Terminal Conducted Tests.....	17
APPENDIX 1: Test Data	18
99 % Occupied Bandwidth	18
6 dB Bandwidth	26
Maximum Conducted Output Power	30
Average Output Power.....	39
Maximum Power Spectral Density	49
Radiated Spurious Emission	61
Conducted Spurious Emission	94
APPENDIX 2: Test Instruments.....	95
APPENDIX 3: Photographs of Test Setup.....	97
Radiated Spurious Emission	97
Antenna Terminal Conducted Tests.....	98

SECTION 1: Customer Information

Company Name	DENSO TEN Limited
Address	2-28, Goshō-dori 1-chome, Hyogo-ku, Kobe, 652-8510 Japan
Telephone Number	+81-78-682-2159
Contact Person	Kaoru Abe

The information provided from the customer is as follows;

- Customer, Description of EUT, Model Number of EUT, FCC ID on the cover and other relevant pages
- Operating/Test Mode(s) (Mode(s)) on all the relevant pages
- SECTION 1: Customer Information
- SECTION 2: Equipment Under Test (EUT) other than the Receipt Date and Test Date
- SECTION 4: Operation of EUT during testing

* The laboratory is exempted from liability of any test results affected from the above information in SECTION 2 and 4.

SECTION 2: Equipment Under Test (EUT)

2.1 Identification of EUT

Description	Car Audio
Model Number	TN0040A
Serial Number	Refer to SECTION 4.2
Condition	Production prototype (Not for Sale: This sample is equivalent to mass-produced items.)
Modification	No Modification by the test lab
Receipt Date	September 20, 2022
Test Date	September 26 to October 11, 2022 and June 14, 2023

2.2 Product Description

General Specification

Rating	DC 12 V
Operating temperature	-30 deg. C to +65 deg. C

Radio Specification

WLAN (IEEE802.11b/11g/11n-20)

Equipment Type	Transceiver
Frequency of Operation	2412 MHz to 2462 MHz
Type of Modulation	DSSS/CCK(11b), OFDM(11g, 11n)
Antenna Gain	0.63 dBi

WLAN (IEEE802.11a/11n-20/11ac-20/11n-40/11ac-40/11ac-80)

Equipment Type	Transceiver	
Frequency of Operation	20 MHz Band:	5180 MHz to 5240 MHz 5745 MHz to 5805 MHz
	40 MHz Band:	5190 MHz to 5230 MHz 5755 MHz to 5795 MHz
	80 MHz Band:	5210 MHz 5775 MHz
Type of Modulation	OFDM(11a, 11n, 11ac)	
Antenna Gain	3.79 dBi (U-NII-1) 3.34 dBi (U-NII-3)	

Bluetooth (BR / EDR)

Equipment Type	Transceiver
Frequency of Operation	2402 MHz to 2480 MHz
Type of Modulation	FHSS (GFSK, $\pi/4$ DQPSK, 8 DPSK)
Antenna Gain	-0.99 dBi

AM/FM (incl. RDS) / DAB

Equipment Type	Receiver
Frequency of Operation	AM: MW:522 kHz to 1710 kHz FM: 87.5 MHz to 108.0 MHz DAB (Band III): 174.928 MHz to 239.200 MHz
Type of Modulation	AM FM DAB: OFDM
Antenna Connector Type	GT21
Impedance	AM, FM: 75 ohm DAB: 50 ohm

SECTION 3: Test specification, Procedures & Results

3.1 Test Specification

Test Specification	FCC Part 15 Subpart E The latest version on the first day of the testing period
Title	FCC 47 CFR Part 15 Radio Frequency Device Subpart E Unlicensed National Information Infrastructure Devices Section 15.407 General technical requirements

3.2 Procedures and Results

Item	Test Procedure	Specification	Worst Margin	Results	Remarks
Conducted Emission	ANSI C63.10-2013	15.407 (b) (6) / 15.207	-	N/A	*1)
26 dB Emission Bandwidth	KDB Publication Number 789033	15.407 (a) (1) (2) (3)	See data	N/A	*2)
Maximum Conducted Output Power	KDB Publication Number 789033	15.407 (a) (1) (2) (3)		Complied a)	Conducted
Maximum Power Spectral Density	KDB Publication Number 789033	15.407 (a) (1) (2) (3)		N/A b)	Conducted
Spurious Emission Restricted Band Edge	ANSI C63.10-2013 KDB Publication Number 789033	15.407 (b), 15.205 and 15.209	4.0 dB 200.0 MHz, QP, Hori.	Complied c) / d)	Conducted (< 30 MHz)/ Radiated (> 30 MHz) *3)
6 dB Emission Bandwidth	ANSI C63.10-2013	15.407 (e)	See data	Complied e)	Conducted

Note: UL Japan, Inc.'s EMI Work Procedures: Work Instructions-ULID-003591 and Work Instructions-ULID-003593.

* In case any questions arise about test procedure, ANSI C63.10: 2013 is also referred.

*1) The test is not applicable since the EUT is not the device that is designed to be connected to the public utility (AC) power line.

*2) The test is not applicable since the EUT does not support W53 and W56 bands.

*3) Radiated test was selected over 30 MHz based on RSS-247 6.2 and KDB 789033 D02 G.3.b).

- a) Refer to APPENDIX 1 (data of Maximum Conducted Output Power)
b) Refer to APPENDIX 1 (data of Maximum Power Spectral Density)
c) Refer to APPENDIX 1 (data of Radiated Spurious Emission)
d) Refer to APPENDIX 1 (data of Conducted Spurious Emission)
e) Refer to APPENDIX 1 (data of 6 dB Bandwidth)

FCC Part 15.31 (e)

This EUT provides the stable voltage constantly to RF Module regardless of input voltage.
Therefore, this EUT complies with the requirement.

FCC Part 15.203 Antenna requirement

It is impossible for end users to replace the antenna, because the antenna is mounted inside of the EUT.
Therefore, the equipment complies with the antenna requirement of Section 15.203.

3.3 Addition to Standard

Item	Test Procedure	Specification	Worst Margin	Results	Remarks
99 % Occupied Band Width	ISED: RSS-Gen 6.7	ISED: -	N/A	- a)	Conducted

a) Refer to APPENDIX 1 (data of 99 % Occupied Bandwidth)

Other than above, no addition, exclusion nor deviation has been made from the standard.

3.4 Uncertainty

Measurement uncertainty is not taken into account when stating conformity with a specified requirement.

Note: When margins obtained from test results are less than the measurement uncertainty, the test results may exceed the limit.

The following uncertainties have been calculated to provide a confidence level of 95 % using a coverage factor $k=2$.

Radiated emission

Measurement distance	Frequency range		Uncertainty (+/-)
3 m	9 kHz to 30 MHz		3.2 dB
10 m			3.0 dB
3 m	30 MHz to 200 MHz	(Horizontal)	4.8 dB
		(Vertical)	5.0 dB
	200 MHz to 1000 MHz	(Horizontal)	5.1 dB
		(Vertical)	6.2 dB
10 m	30 MHz to 200 MHz	(Horizontal)	4.8 dB
		(Vertical)	4.8 dB
	200 MHz to 1000 MHz	(Horizontal)	5.0 dB
		(Vertical)	5.0 dB
3 m	1 GHz to 6 GHz		4.9 dB
	6 GHz to 18 GHz		5.2 dB
1 m	10 GHz to 26.5 GHz		5.4 dB
	26.5 GHz to 40 GHz		5.4 dB
0.5 m	26.5 GHz to 40 GHz		5.4 dB
10 m	1 GHz to 18 GHz		5.4 dB

Antenna Terminal test

Test Item	Uncertainty (+/-)
26 dB Emission Bandwidth / 6 dB Emission Bandwidth / 99 % Occupied Bandwidth	0.96 %
Maximum Conducted Output Power / Average Output Power	1.5 dB
Burst Rate	0.10 %
Maximum Power Spectral Density	2.7 dB
Conducted Spurious Emission	2.7 dB

3.5 Test Location

UL Japan, Inc. Ise EMC Lab.

*A2LA Certificate Number: 5107.02 / FCC Test Firm Registration Number: 884919

ISED Lab Company Number: 2973C / CAB identifier: JP0002

4383-326 Asama-cho, Ise-shi, Mie-ken 516-0021 Japan

Telephone: +81-596-24-8999

Test site	Width x Depth x Height (m)	Size of reference ground plane (m) / horizontal conducting plane	Other rooms	Maximum measurement distance
No.1 semi-anechoic chamber	19.2 x 11.2 x 7.7	7.0 x 6.0	No.1 Power source room	10 m
No.2 semi-anechoic chamber	7.5 x 5.8 x 5.2	4.0 x 4.0	-	3 m
No.3 semi-anechoic chamber	12.0 x 8.5 x 5.9	6.8 x 5.75	No.3 Preparation room	3 m
No.3 shielded room	4.0 x 6.0 x 2.7	N/A	-	-
No.4 semi-anechoic chamber	12.0 x 8.5 x 5.9	6.8 x 5.75	No.4 Preparation room	3 m
No.4 shielded room	4.0 x 6.0 x 2.7	N/A	-	-
No.5 semi-anechoic chamber	6.0 x 6.0 x 3.9	6.0 x 6.0	-	-
No.5 measurement room	6.4 x 6.4 x 3.0	6.4 x 6.4	-	-
No.6 shielded room	4.0 x 4.5 x 2.7	4.0 x 4.5	-	-
No.6 measurement room	4.75 x 5.4 x 3.0	4.75 x 4.15	-	-
No.7 shielded room	4.7 x 7.5 x 2.7	4.7 x 7.5	-	-
No.8 measurement room	3.1 x 5.0 x 2.7	3.1 x 5.0	-	-
No.9 measurement room	8.8 x 4.6 x 2.8	2.4 x 2.4	-	-
No.10 shielded room	3.8 x 2.8 x 2.8	3.8 x 2.8	-	-
No.11 measurement room	4.0 x 3.4 x 2.5	N/A	-	-
No.12 measurement room	2.6 x 3.4 x 2.5	N/A	-	-
Large Chamber	16.9 x 22.1 x 10.17	16.9 x 22.1	-	10 m
Small Chamber	5.3 x 6.69 x 3.59	5.3 x 6.69	-	-

3.6 Test Data, Test Instruments, and Test Set Up

Refer to APPENDIX.

SECTION 4: Operation of EUT during testing

4.1 Operating Mode(s)

Test operating mode was determined as follows according to “Section 1 of 6 802.11 a/b/g/n testing - Managing Complex Regulatory Approvals -” of TCB Council Workshop October 2009.

Mode	Remarks*
IEEE 802.11a (11a)	54 Mbps, PN9
IEEE 802.11n SISO 20 MHz BW (11n-20)	MCS 6 (Long GI), PN9
IEEE 802.11ac SISO 20 MHz BW (11ac-20)	MCS 6 (Long GI), PN9
IEEE 802.11n SISO 40 MHz BW (11n-40)	MCS 6 (Long GI), PN9
IEEE 802.11ac SISO 40 MHz BW (11ac-40)	MCS 6 (Long GI), PN9
IEEE 802.11ac SISO 80 MHz BW (11ac-80)	MCS 9 (Long GI), PN9
<p>*Power of the EUT was set by the software as follows; Power Setting: 11a: +6.5 dBm 11n-20: +6.5 dBm 11n-40: +6.5 dBm 11ac-20: +6.5 dBm 11ac-40: +6.5 dBm 11ac-80: +6.5 dBm Software: 1A.00.12.78.00 (Date: September 5, 2022, Storage location: EUT memory) *This setting of software is the worst case. Any conditions under the normal use do not exceed the condition of setting. In addition, end users cannot change the settings of the output power of the product.</p>	

*The Details of Operation Mode(s)

Test Item	Operating Mode	Tested Frequency			
		Lower Band	Middle Band	Additional Band	Upper Band
99 % Occupied Bandwidth, Maximum Conducted Output Power, Maximum Power Spectral Density	Tx 11a	5180 MHz	-	-	5745 MHz
	Tx 11n-20	5220 MHz	-	-	5785 MHz
	Tx 11ac-20	5240 MHz	-	-	5805 MHz
	Tx 11n-40	5190 MHz	-	-	5755 MHz
	Tx 11ac-40	5230 MHz	-	-	5795 MHz
	Tx 11ac-80	5210 MHz	-	-	5775 MHz
6 dB Bandwidth	Tx 11a	-	-	-	5745 MHz
	Tx 11n-20	-	-	-	5785 MHz
	Tx 11ac-20	-	-	-	5805 MHz
	Tx 11n-40	-	-	-	5755 MHz
	Tx 11ac-40	-	-	-	5795 MHz
	Tx 11ac-80	-	-	-	5775 MHz
Radiated Spurious Emission, (Below 1 GHz) Conducted Spurious Emission	Tx 11ac-20 *1)	5180 MHz	-	-	-
Radiated Spurious Emission (Above 1 GHz)	Tx 11a	5180 MHz	-	-	5745 MHz
	Tx 11ac-20	5220 MHz 5240 MHz	-	-	5785 MHz 5805 MHz
	Tx 11ac-40	5190 MHz 5230 MHz	-	-	5755 MHz 5795 MHz
	Tx 11ac-80	5210 MHz	-	-	5775 MHz
*1) The mode was tested as a representative, because it had the highest power at antenna terminal test.					

4.2 Configuration and Peripherals
For Radiated emission tests

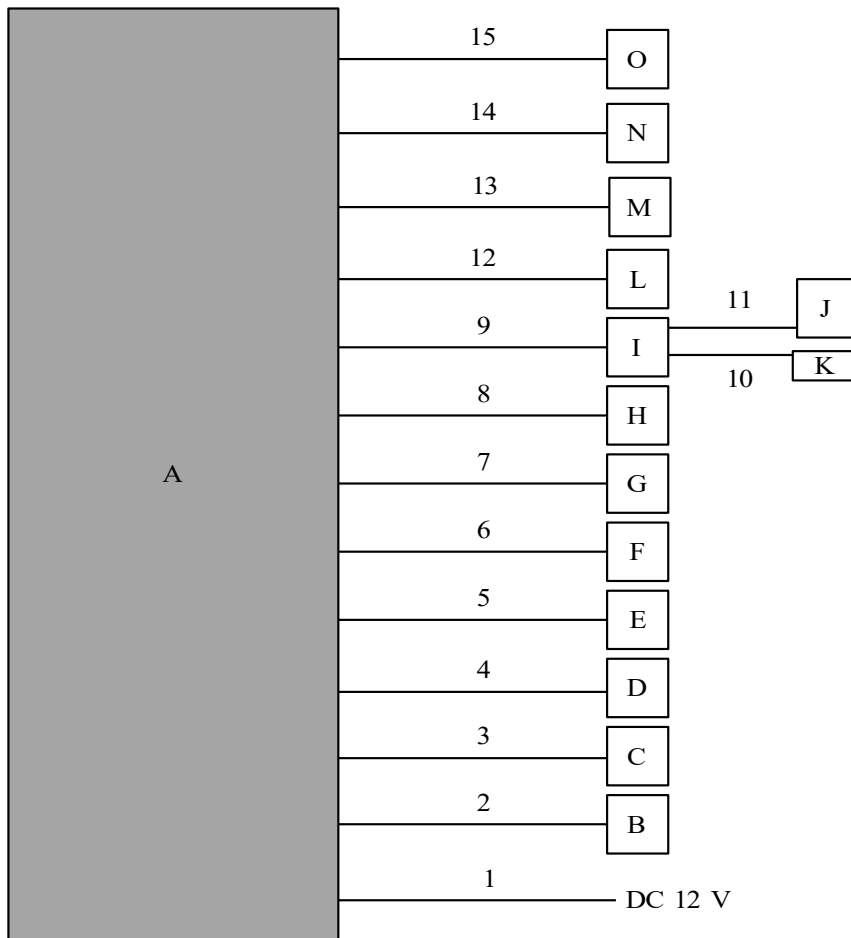

* Cabling and setup(s) were taken into consideration and test data was taken under worse case conditions.

Description of EUT and Support Equipment

No.	Item	Model Number	Serial Number	Manufacturer	Remarks
A	Car Audio	TN0040A	NAVI-0029	DENSO TEN Limited	EUT
B	Microphone	8983963631	1Y141500310277	Transtron	-
C	Analog Camera	8983980531	0289018	Faurecia Clarion Electronics	-
D	Digital Camera	5JX4707170	0112	AISIN	-
E	Steering Switch	876521340	-	TOYODENSO	-
F	Meter	8976834551	A220405111418	YAZAKI	-
G	Radio and DAB Antenna	8983960350	-	HARADA INDUSTRY	-
H	GPS Antenna	8983963531	-	JVCKENWOOD	-
I	Rear USB CN	-	No.1	-	-
J	Smartphone	Pixel 4a(5G)	87667	-	-
K	USB Memory	RUF3-K8GA-BK/N	P90611	BUFFALO	-
L	Speaker	-	-	-	-
M	Speaker	-	-	-	-
N	Speaker	-	-	-	-
O	Speaker	-	-	-	-

List of Cables Used

No.	Name	Length (m)	Shield		Remarks
			Cable	Connector	
1	DC Cable	5.0	Unshielded	Unshielded	-
2	MIC Cable	3.0	Unshielded	Unshielded	-
3	Signal Cable	3.0	Unshielded	Unshielded	-
4	Signal Cable	9.6	Unshielded	Unshielded	-
5	Signal Cable	3.0	Unshielded	Unshielded	-
6	Signal Cable	3.0	Unshielded	Unshielded	-
7	Antenna Cable	2.7	Shielded	Shielded	-
8	GNSS Antenna Cable	3.0	Shielded	Shielded	-
9	Signal Cable	3.0	Unshielded	Unshielded	-
10	USB Cable	3.0	Shielded	Shielded	-
11	USB Cable	1.6	Shielded	Shielded	-
12	Speaker Cable	3.0	Unshielded	Unshielded	-
13	Speaker Cable	3.0	Unshielded	Unshielded	-
14	Speaker Cable	3.0	Unshielded	Unshielded	-
15	Speaker Cable	3.0	Unshielded	Unshielded	-
16	Flexible Flat Cable	0.1	Unshielded	Unshielded	-

For Antenna Terminal Conducted tests

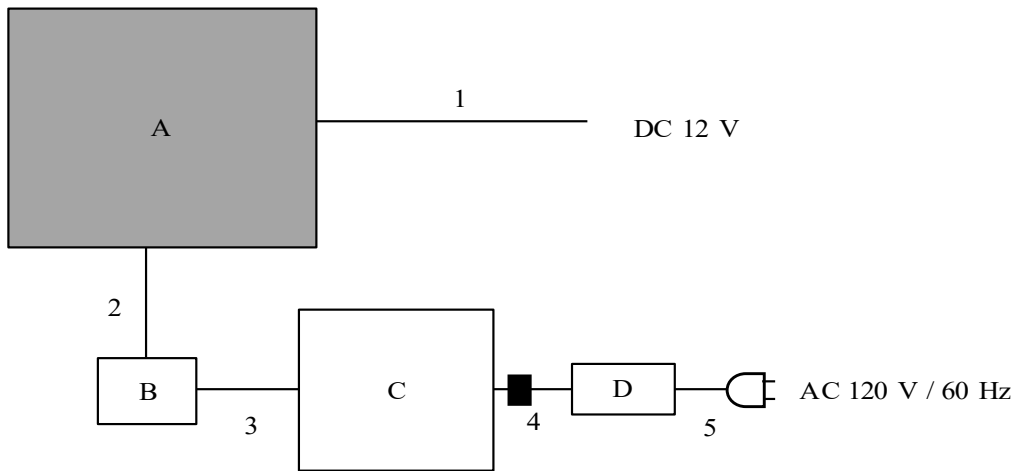

■ : Standard Ferrite Core

* Cabling and setup(s) were taken into consideration and test data was taken under worse case conditions.

No.	Item	Model Number	Serial Number	Manufacturer	Remarks
A	Car Audio	TN0040A	NAVI-0024	DENSO TEN Limited	EUT
B	RG14 Debug Board	-	-	-	-
C	Laptop PC	X1 Carbon	R90OH8TU 15/9	Lenovo	-
D	AC Adaptor	ADLX45NCC2A	8SSA10E75794C1SG59R0GHF	Lenovo	-

List of Cables Used

No.	Name	Length (m)	Shield		Remarks
			Cable	Connector	
1	DC Cable	5.0	Unshielded	Unshielded	-
2	Flexible Flat Cable	0.1	Unshielded	Unshielded	-
3	USB Cable	1.5	Shielded	Shielded	-
4	DC Cable	1.7	Unshielded	Unshielded	-
5	AC Cable	1.0	Unshielded	Unshielded	-

SECTION 5: Radiated Spurious Emission and Band Edge Compliance

Test Procedure

< Below 1GHz >

EUT was placed on a urethane platform of nominal size, 0.5 m by 1.0 m, raised 0.8 m above the conducting ground plane. The Radiated Electric Field Strength has been measured in a Semi Anechoic Chamber with a ground plane.

< Above 1GHz >

EUT was placed on a urethane platform of nominal size, 0.5 m by 0.5 m, raised 1.5 m above the conducting ground plane.

The Radiated Electric Field Strength has been measured in a Semi Anechoic Chamber with absorbent materials lined on a ground plane.

The height of the measuring antenna varied between 1 m and 4 m and EUT was rotated a full revolution in order to obtain the maximum value of the electric field strength.

Test antenna was aimed at the EUT for receiving the maximum signal and always kept within the illumination area of the 3 dB beamwidth of the antenna.

The measurements were performed for both vertical and horizontal antenna polarization with the Test Receiver, or the Spectrum Analyzer.

The measurements were made with the following detector function of the test receiver and the Spectrum analyzer (in linear mode).

The test was made with the detector (RBW/VBW) in the following table.

When using Spectrum analyzer, the test was made with adjusting span to zero by using peak hold.

< Below 1GHz >

The result also satisfied with the general limits specified in section 15.209 (a).

< Above 1GHz >

Inside of restricted bands (Section 15.205):

Apply to limit in the Section 15.209 (a).

Outside of the restricted bands:

Apply to limit 68.2 dBuV/m, 3 m (-27 dBm e.i.r.p. *) in the Section 15.407 (b) (1) (2) (3).

For W58 Bandedge

-27 dBm/MHz at 75 MHz or more above or below the band edge increasing linearly to 10 dBm/MHz at 25 MHz above or below the band edge, and from 25 MHz above or below the band edge increasing linearly to a level of 15.6 dBm/MHz at 5 MHz above or below the band edge, and from 5 MHz above or below the band edge increasing linearly to a level of 27 dBm/MHz at the band edge in the section 15.407(b)(4)(i).

Restricted band edge:

Apply to limit in the Section 15.209 (a).

Since this limit is severer than the limit of the inside of restricted bands.

*Electric field strength to e.i.r.p. conversion:

$$E = \frac{1000000 \sqrt{30P}}{3} \text{ (uV/m)} \quad :P \text{ is the e.i.r.p. (Watts)}$$

Test Antennas are used as below;

Frequency	30 MHz to 200 MHz	200 MHz to 1 GHz	Above 1 GHz
Antenna Type	Biconical	Logperiodic	Horn

Frequency	Below 1 GHz	Above 1 GHz	
Instrument Used	Test Receiver	Spectrum Analyzer	
Detector	QP	Peak	Average
IF Bandwidth	BW: 120 kHz	RBW: 1 MHz VBW: 3 MHz	Method AD *1) RBW: 1 MHz VBW: 3 MHz Detector: Power Averaging (RMS) Trace: ≥ 100 traces If duty cycle was less than 98%, a duty factor was added to the results.

*1) The test method was also referred to KDB 789033 D02 General UNII Test Procedures New Rules v02r01 "Guidelines for Compliance Testing of Unlicensed National Information Infrastructure (U-NII) Devices Part 15, Subpart E".

Figure 1: Test Setup

Below 1 GHz

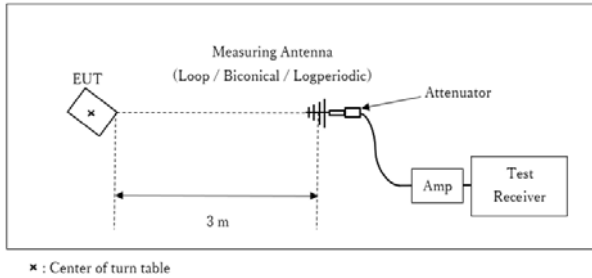

Test Distance: 3 m

1 GHz to 10 GHz

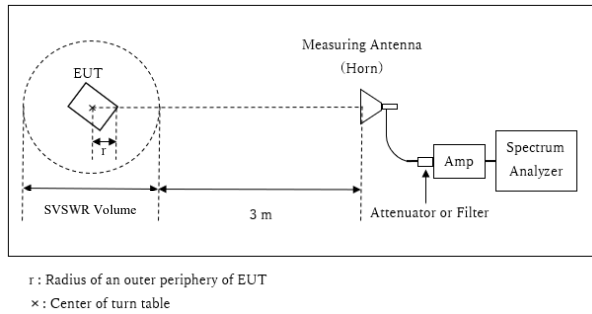

Distance Factor: $20 \times \log(3.6 \text{ m} / 3.0 \text{ m}) = 1.59 \text{ dB}$
* Test Distance: $(3 + \text{SVSWR Volume} / 2) - r = 3.6 \text{ m}$

SVSWR Volume : 1.5 m
(SVSWR Volume has been calibrated based on CISPR 16-1-4.)
 $r = 0.15 \text{ m}$

10 GHz to 40 GHz

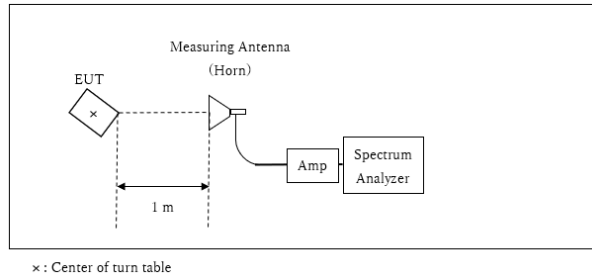

Distance Factor: $20 \times \log(1.0 \text{ m} / 3.0 \text{ m}) = -9.5 \text{ dB}$
*Test Distance: 1 m

The test was made on EUT at the normal use position.

The test results and limit are rounded off to one decimal place, so some differences might be observed.

Measurement Range : 30 MHz to 40 GHz
Test Data : APPENDIX
Test Result : Pass

SECTION 6: Antenna Terminal Conducted Tests

Test Procedure

The tests were made with below setting connected to the antenna port.

Test	Span	RBW	VBW	Sweep time	Detector	Trace	Instrument used and Test method
99 % Occupied Bandwidth *1)	Enough width to display emission skirts	1 % to 5 % of OBW	≥ 3 RBW	Auto	Peak	Max Hold	Spectrum Analyzer
6 dB Bandwidth	Enough to capture the emission	100 kHz	300 kHz	Auto	Peak	Max Hold	Spectrum Analyzer
Maximum Conducted Output Power	-	-	-	Auto	Average	-	Power Meter (Sensor: 80 MHz BW) (Method PM))
Maximum Power Spectral Density	Encompass the entire EBW	1 MHz *4) 470 kHz *5)	≥ 3 RBW	Auto	RMS Power Averaging (200 times)	Clear Write	Spectrum Analyzer
Conducted Spurious Emission*2) *3)	9 kHz to 150 kHz	200 Hz	620 Hz	Auto	Peak	Max Hold	Spectrum Analyzer
	150 kHz to 30 MHz	9.1 kHz	27 kHz				

* The test method was also referred to KDB 789033 D02 General UNII Test Procedures New Rules v02r01 "Guidelines for Compliance Testing of Unlicensed National Information Infrastructure (U-NII) Devices Part 15, Subpart E".

*1) Peak hold was applied as Worst-case measurement.

*2) In the frequency range below 30 MHz, RBW was narrowed to separate the noise contents.

Then, wide-band noise near the limit was checked separately, however the noise was not detected as shown in the chart. (9 kHz to 150 kHz: RBW = 200 Hz, 150 kHz to 30 MHz: RBW = 9.1 kHz)

*3) The limits in CFR 47, Part 15, Subpart C, paragraph 15.209(a), are identical to those in RSS-Gen section 8.9, Table 6, since the measurements are performed in terms of magnetic field strength and converted to electric field strength levels (as reported in the table) using the free space impedance of 377 Ohms. For example, the measurement at frequency 9 kHz resulted in a level of 45.5 dBuV/m, which is equivalent to 45.5 – 51.5 = -6.0 dBuA/m, which has the same margin, 3 dB, to the corresponding RSS-Gen Table 6 limit as it has to 15.209(a) limit.

*4) Used for 5180 MHz to 5240 MHz.

*5) Used for 5745 MHz to 5805 MHz.

The test results and limit are rounded off to two decimals place, so some differences might be observed. The equipment and cables were not used for factor 0 dB of the data sheets.

Test Data : APPENDIX
Test Result : Pass

APPENDIX 1: Test Data

99 % Occupied Bandwidth

Test place Ise EMC Lab. No.4 Measurement Room
Date October 11, 2022
Temperature / Humidity 23 deg. C / 55 % RH
Engineer Takumi Nishida
Mode Tx

11a

Tested Frequency [MHz]	99 % Occupied Bandwidth [kHz]
5180	16899.1
5220	16863.4
5240	16869.1
5745	16941.2
5785	16880.4
5805	16870.7

11n-20

Tested Frequency [MHz]	99 % Occupied Bandwidth [kHz]
5180	18062.4
5220	18057.2
5240	18027.3
5745	18125.2
5785	18141.9
5805	18089.5

11ac-20

Tested Frequency [MHz]	99 % Occupied Bandwidth [kHz]
5180	18182.0
5220	18188.4
5240	18122.8
5745	18105.7
5785	18168.3
5805	18138.6

99 % Occupied Bandwidth

Test place Ise EMC Lab. No.8 Measurement Room
Date June 14, 2023
Temperature / Humidity 23 deg. C / 54 % RH
Engineer Takumi Nishida
Mode Tx

11n-40

Tested Frequency [MHz]	99 % Occupied Bandwidth [kHz]
5190	36444.0
5230	36419.9
5755	36342.8
5795	36475.8

11ac-40

Tested Frequency [MHz]	99 % Occupied Bandwidth [kHz]
5190	36451.9
5230	36446.4
5755	36479.0
5795	36465.7

11ac-80

Tested Frequency [MHz]	99 % Occupied Bandwidth [kHz]
5210	75793.0
5775	75747.5

99 % Occupied Bandwidth

11a

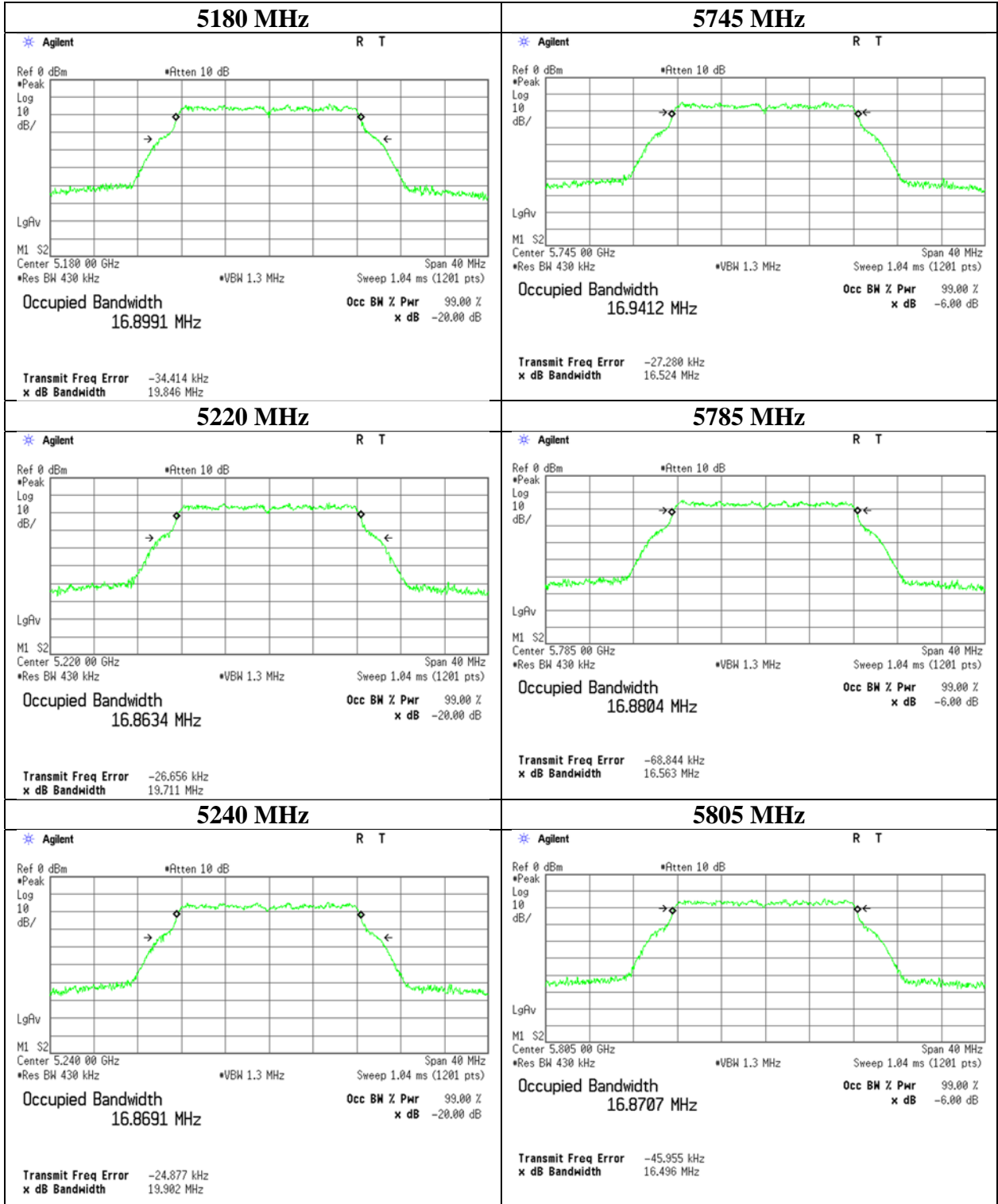

99 % Occupied Bandwidth

11n-20

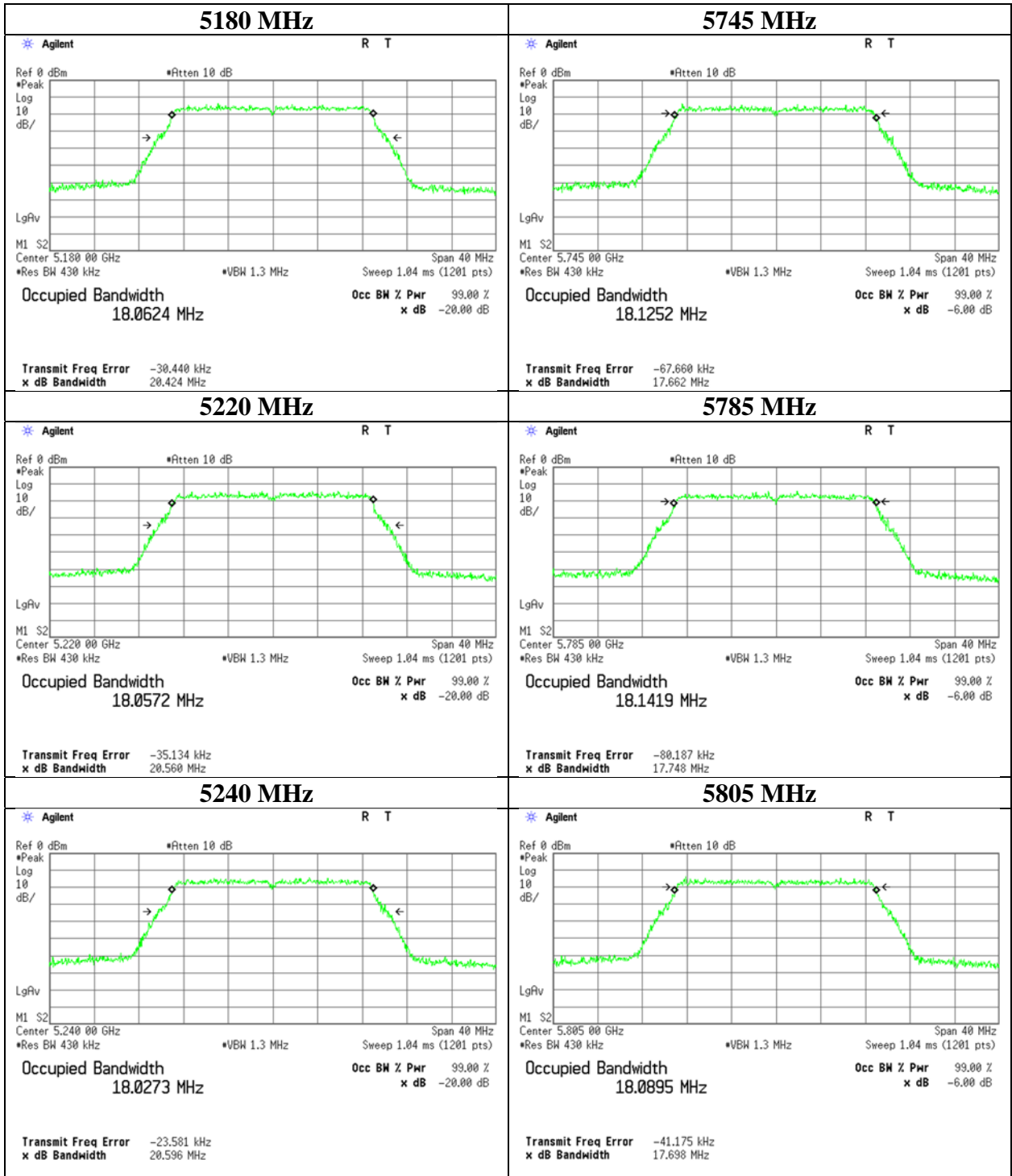

99 % Occupied Bandwidth

11ac-20

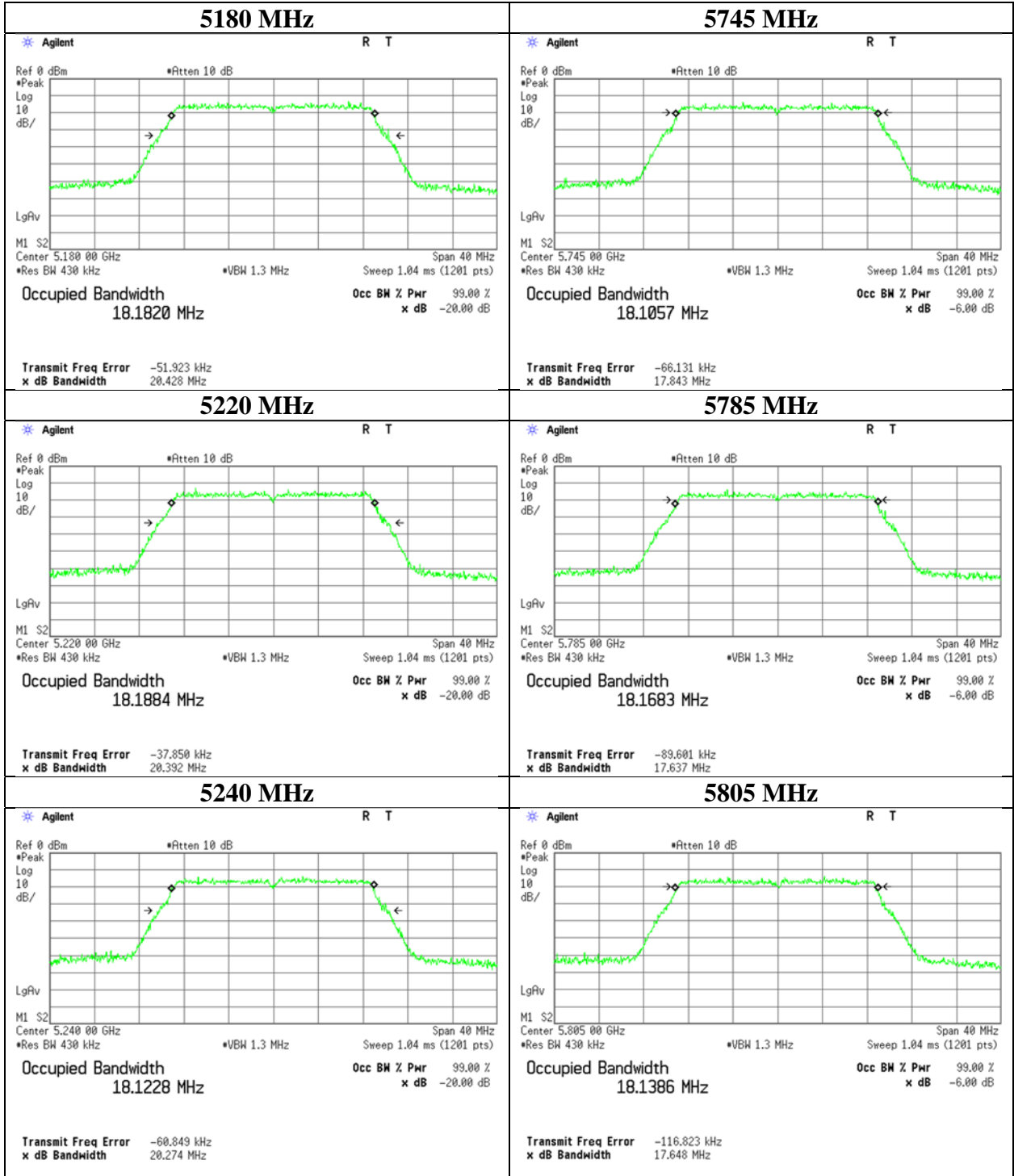

99 % Occupied Bandwidth

11n-40

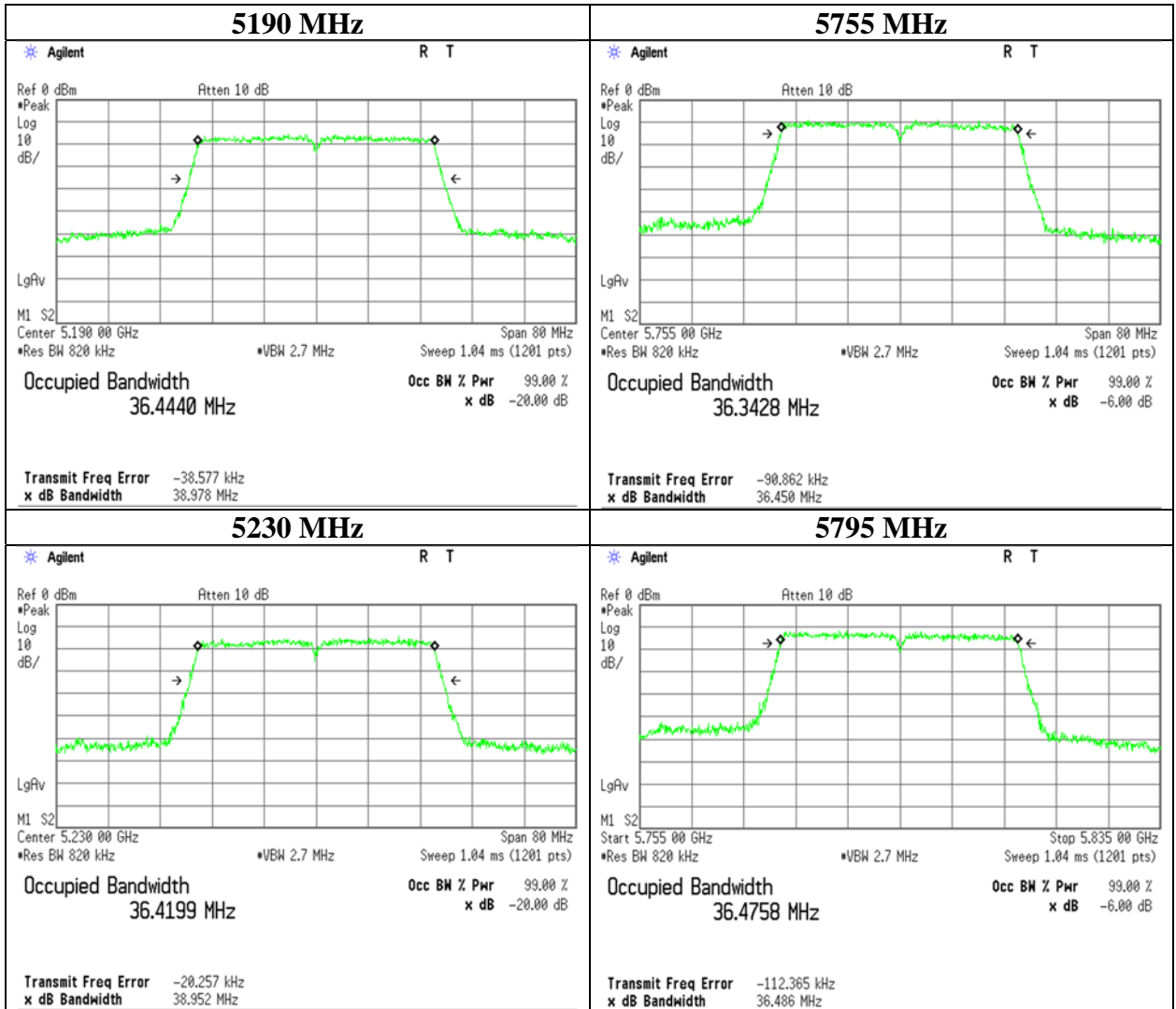

99 % Occupied Bandwidth

11ac-40

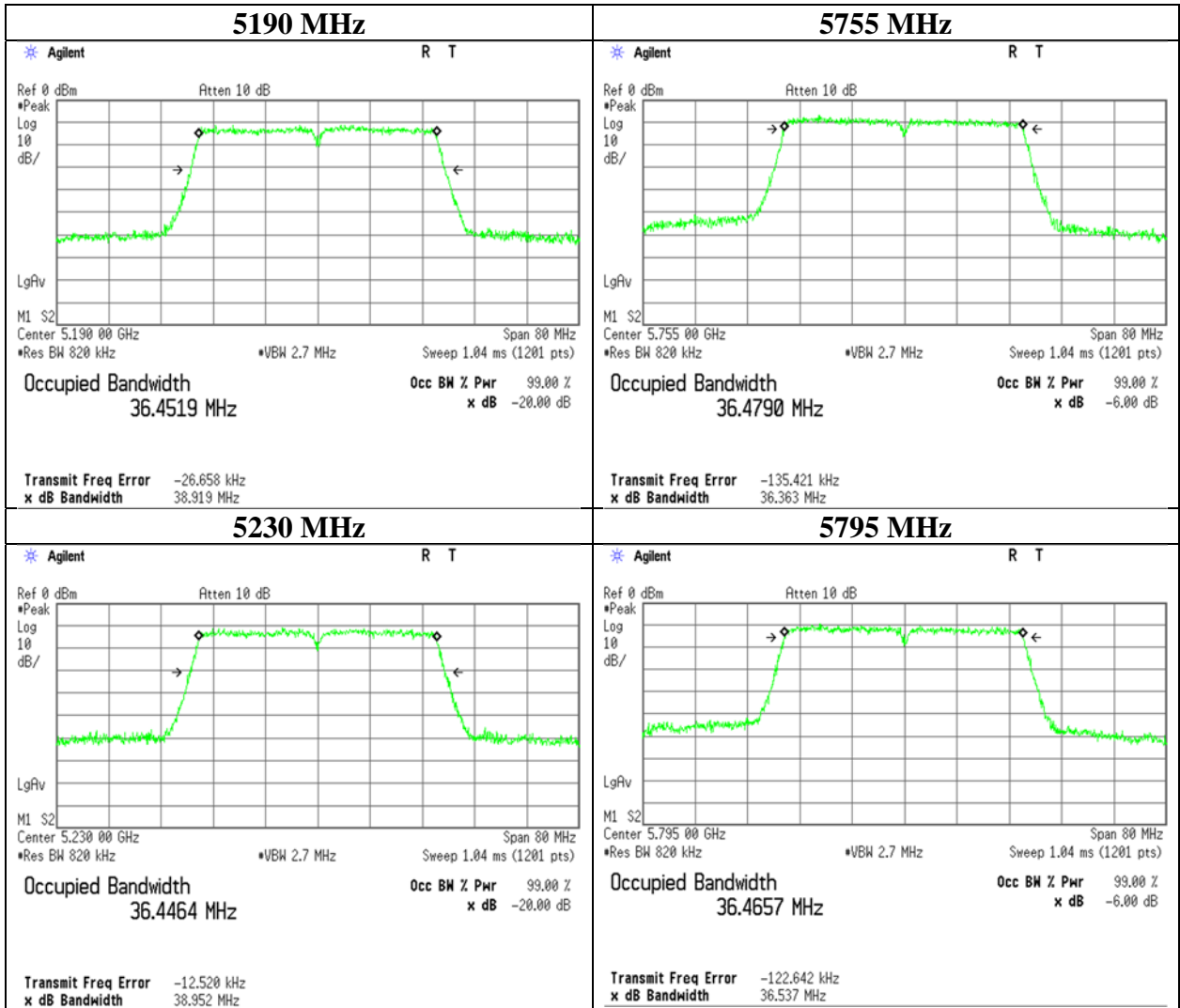

99 % Occupied Bandwidth

11ac-80

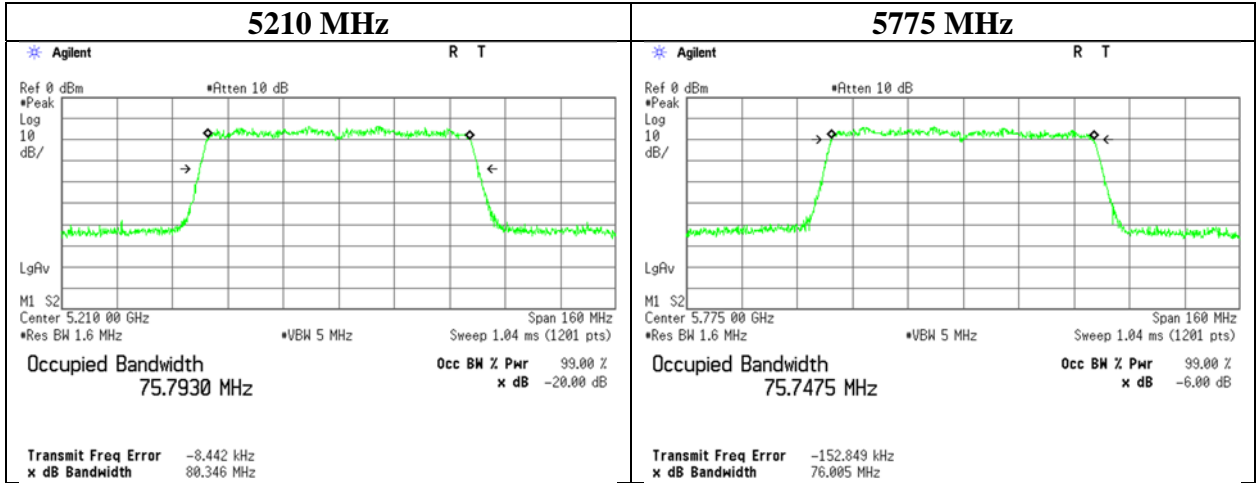

6 dB Bandwidth

Test place	Ise EMC Lab. No.4 Measurement Room
Date	October 11, 2022
Temperature / Humidity	23 deg. C / 55 % RH
Engineer	Takumi Nishida
Mode	Tx

11a

Tested Frequency [MHz]	6 dB Bandwidth [MHz]	Limit [MHz]
5745	16.436	> 0.500
5785	16.388	> 0.500
5805	16.455	> 0.500

11n-20

Tested Frequency [MHz]	6 dB Bandwidth [MHz]	Limit [MHz]
5745	17.708	> 0.500
5785	17.744	> 0.500
5805	17.730	> 0.500

11ac-20

Tested Frequency [MHz]	6 dB Bandwidth [MHz]	Limit [MHz]
5745	17.716	> 0.500
5785	17.723	> 0.500
5805	17.685	> 0.500

11n-40

Tested Frequency [MHz]	6 dB Bandwidth [MHz]	Limit [MHz]
5755	36.430	> 0.500
5795	36.477	> 0.500

11ac-40

Tested Frequency [MHz]	6 dB Bandwidth [MHz]	Limit [MHz]
5755	36.401	> 0.500
5795	36.475	> 0.500

11ac-80

Tested Frequency [MHz]	6 dB Bandwidth [MHz]	Limit [MHz]
5775	75.751	> 0.500

6 dB Bandwidth

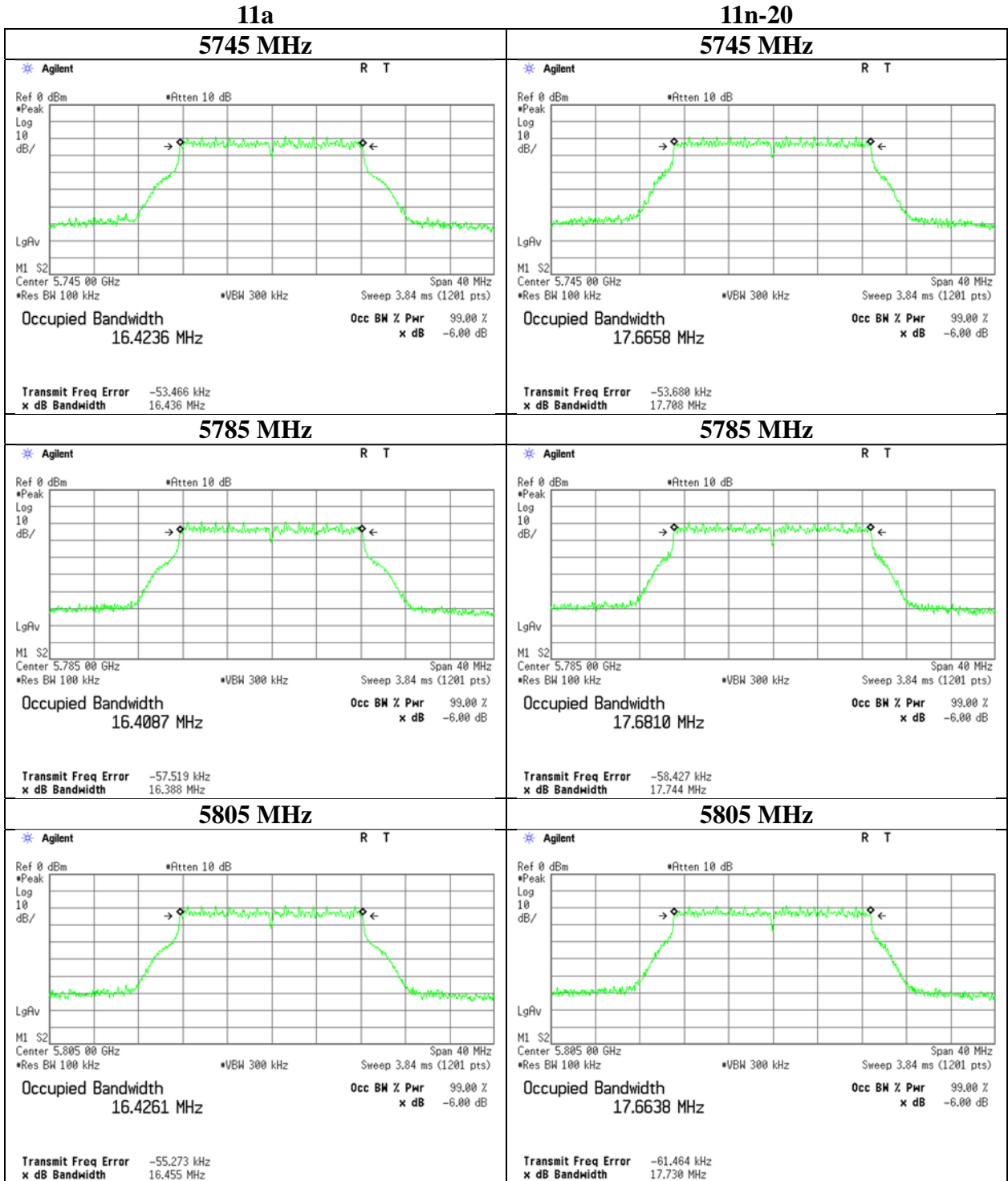

6 dB Bandwidth

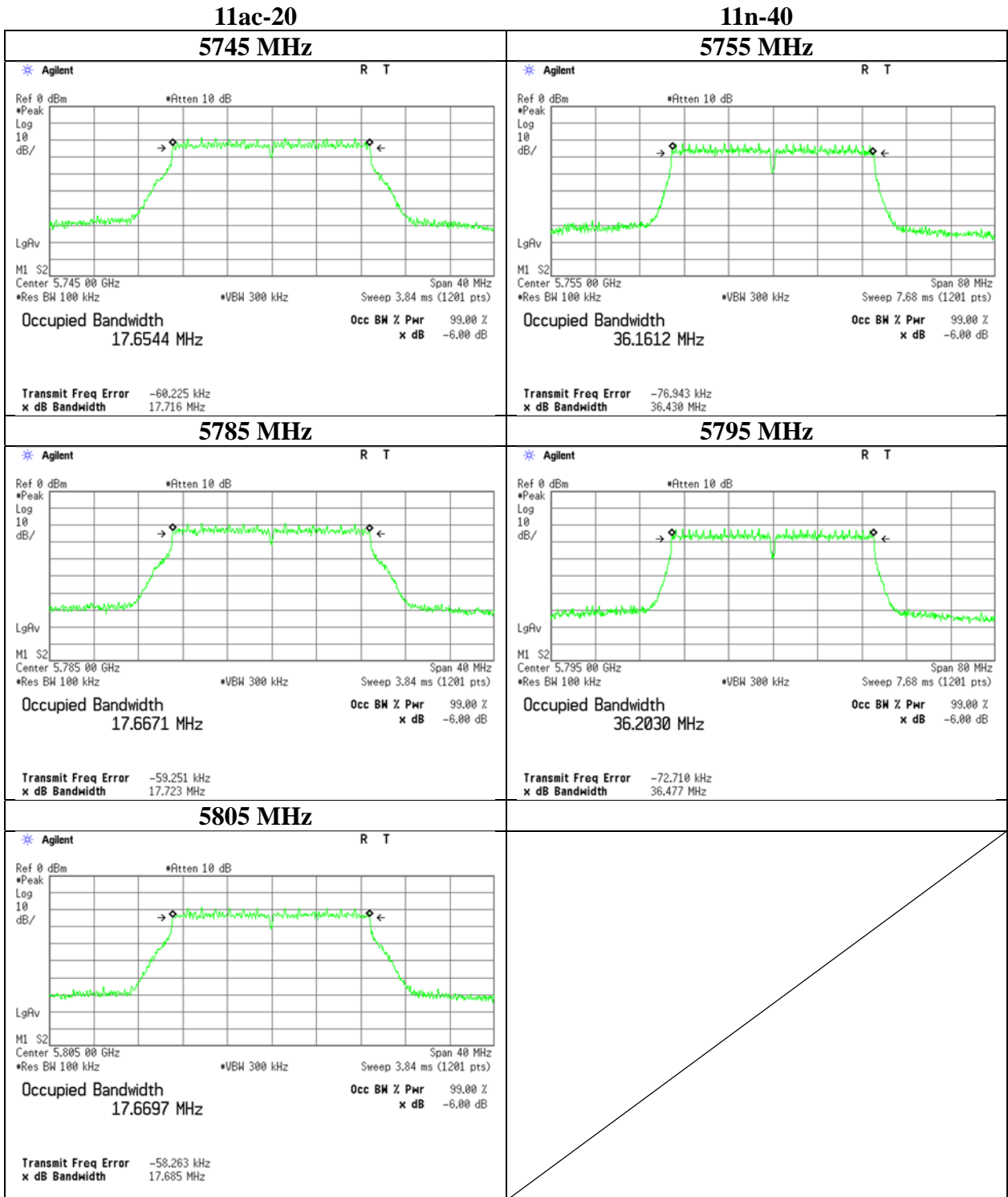

6 dB Bandwidth

11ac-40

5755 MHz

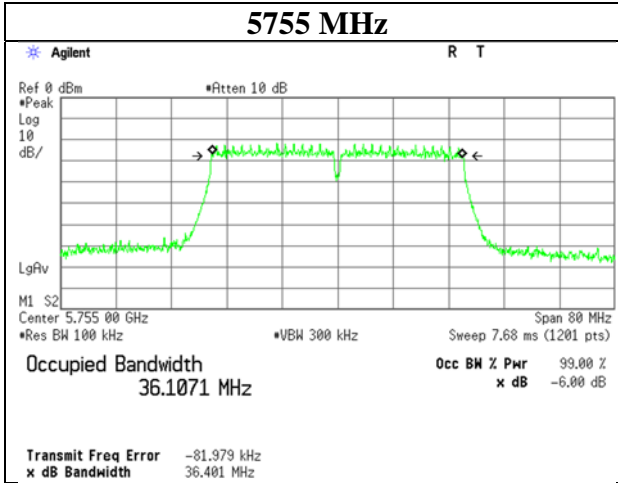

11ac-80, Antenna 1

5775 MHz

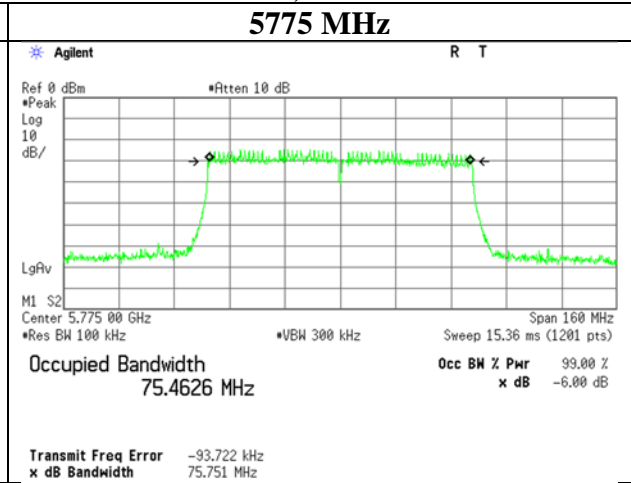

5795 MHz

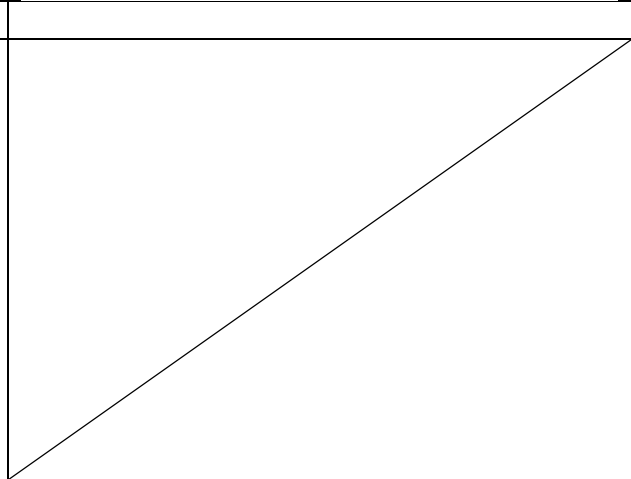
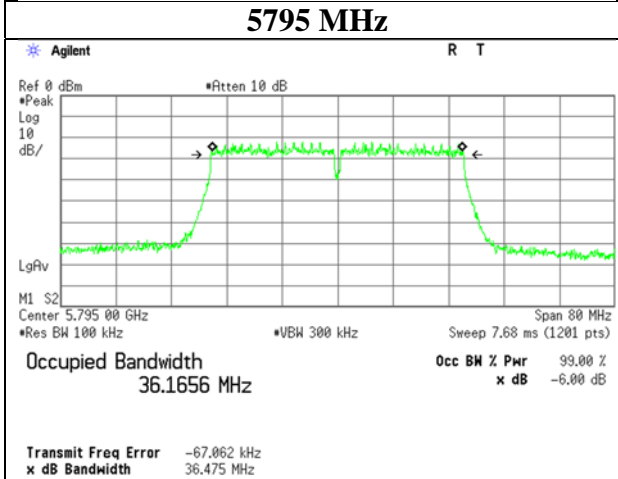

Maximum Conducted Output Power

Test place	Ise EMC Lab. No.7 Shielded Room
Date	September 26, 2022
Temperature / Humidity	20 deg. C / 45 % RH
Engineer	Junya Okuno
Mode	Tx 11a

11a

Applied limit: 15.407, mobile and portable client device

Tested Frequency [MHz]	Power Meter Reading [dBm]	Cable Loss [dB]	Atten. Loss [dB]	Duty Factor [dB]	Antenna Gain [dBi]	Conducted Power				e.i.r.p.			
						Result		Limit	Margin	Result		Limit	Margin
						[dBm]	[mW]			[dBm]	[mW]		
5180	-7.82	0.80	10.13	1.86	3.79	4.97	3.14	23.97	19.00	8.76	7.52	29.97	21.21
5220	-8.10	0.80	10.13	1.86	3.79	4.69	2.94	23.97	19.28	8.48	7.05	29.97	21.49
5240	-8.24	0.80	10.13	1.86	3.79	4.55	2.85	23.97	19.42	8.34	6.82	29.97	21.63
5745	-8.24	0.80	10.14	1.86	3.34	4.56	2.86	30.00	25.44	7.90	6.17	36.00	28.10
5785	-8.06	0.80	10.14	1.86	3.34	4.74	2.98	30.00	25.26	8.08	6.43	36.00	27.92
5805	-7.86	0.80	10.14	1.86	3.34	4.94	3.12	30.00	25.06	8.28	6.73	36.00	27.72

Sample Calculation:

Conducted Power Result = Reading + Cable Loss (including the cable(s) customer supplied) + Atten. Loss + Duty Factor

e.i.r.p. Result = Conducted Power Result + Antenna Gain

Conducted Power Limit (5725 MHz-5850 MHz) = 1W

Maximum Conducted Output Power

Test place	Ise EMC Lab. No.7 Shielded Room
Date	September 26, 2022
Temperature / Humidity	20 deg. C / 45 % RH
Engineer	Junya Okuno
Mode	Tx 11n-20

11n-20

Applied limit: 15.407, mobile and portable client device

Tested Frequency [MHz]	Power Meter Reading [dBm]	Cable Loss [dB]	Atten. Loss [dB]	Duty Factor [dB]	Antenna Gain [dBi]	Conducted Power				e.i.r.p.			
						Result		Limit	Margin	Result		Limit	Margin
						[dBm]	[mW]			[dBm]	[mW]		
5180	-7.58	0.80	10.13	1.82	3.79	5.17	3.29	23.97	18.80	8.96	7.87	29.97	21.01
5220	-8.03	0.80	10.13	1.82	3.79	4.72	2.96	23.97	19.25	8.51	7.10	29.97	21.46
5240	-8.20	0.80	10.13	1.82	3.79	4.55	2.85	23.97	19.42	8.34	6.82	29.97	21.63
5745	-8.08	0.80	10.14	1.82	3.34	4.68	2.94	30.00	25.32	8.02	6.34	36.00	27.98
5785	-7.96	0.80	10.14	1.82	3.34	4.80	3.02	30.00	25.20	8.14	6.52	36.00	27.86
5805	-7.85	0.80	10.14	1.82	3.34	4.91	3.10	30.00	25.09	8.25	6.68	36.00	27.75

Sample Calculation:

Conducted Power Result = Reading + Cable Loss (including the cable(s) customer supplied) + Atten. Loss + Duty Factor

e.i.r.p. Result = Conducted Power Result + Antenna Gain

Conducted Power Limit (5725 MHz-5850 MHz) = 1W

Maximum Conducted Output Power

Test place	Ise EMC Lab. No.7 Shielded Room
Date	September 26, 2022
Temperature / Humidity	20 deg. C / 45 % RH
Engineer	Junya Okuno
Mode	Tx 11ac-20

11ac-20

Applied limit: 15.407, mobile and portable client device

Tested Frequency [MHz]	Power Meter Reading [dBm]	Cable Loss [dB]	Atten. Loss [dB]	Duty Factor [dB]	Antenna Gain [dBi]	Conducted Power				e.i.r.p.			
						Result		Limit [dBm]	Margin [dB]	Result		Limit [dBm]	Margin [dB]
						[dBm]	[mW]			[dBm]	[mW]		
5180	-7.54	0.80	10.13	1.79	3.79	5.18	3.30	23.97	18.79	8.97	7.89	29.97	21.00
5220	-7.95	0.80	10.13	1.79	3.79	4.77	3.00	23.97	19.20	8.56	7.18	29.97	21.41
5240	-8.16	0.80	10.13	1.79	3.79	4.56	2.86	23.97	19.41	8.35	6.84	29.97	21.62
5745	-8.02	0.80	10.14	1.79	3.34	4.71	2.96	30.00	25.29	8.05	6.38	36.00	27.95
5785	-7.92	0.80	10.14	1.79	3.34	4.81	3.03	30.00	25.19	8.15	6.53	36.00	27.85
5805	-7.80	0.80	10.14	1.79	3.34	4.93	3.11	30.00	25.07	8.27	6.71	36.00	27.73

Sample Calculation:

Conducted Power Result = Reading + Cable Loss (including the cable(s) customer supplied) + Atten. Loss + Duty Factor

e.i.r.p. Result = Conducted Power Result + Antenna Gain

Conducted Power Limit (5725 MHz-5850 MHz) = 1W

Maximum Conducted Output Power

Test place Ise EMC Lab. No.7 Shielded Room
Date September 26, 2022
Temperature / Humidity 20 deg. C / 45 % RH
Engineer Junya Okuno
Mode Tx 11n-40

11n-40

Applied limit: 15.407, mobile and portable client device

Tested Frequency [MHz]	Power Meter Reading [dBm]	Cable Loss [dB]	Atten. Loss [dB]	Duty Factor [dB]	Antenna Gain [dBi]	Conducted Power				e.i.r.p.			
						Result [dBm]	[mW]	Limit [dBm]	Margin [dB]	Result [dBm]	[mW]	Limit [dBm]	Margin [dB]
5190	-9.24	0.80	10.13	2.70	3.79	4.39	2.75	23.97	19.58	8.18	6.58	29.97	21.79
5230	-9.54	0.80	10.13	2.70	3.79	4.09	2.56	23.97	19.88	7.88	6.14	29.97	22.09
5755	-9.30	0.80	10.14	2.70	3.34	4.34	2.72	30.00	25.66	7.68	5.86	36.00	28.32
5795	-9.28	0.80	10.14	2.70	3.34	4.36	2.73	30.00	25.64	7.70	5.89	36.00	28.30

Sample Calculation:

Conducted Power Result = Reading + Cable Loss (including the cable(s) customer supplied) + Atten. Loss + Duty Factor

e.i.r.p. Result = Conducted Power Result + Antenna Gain

Conducted Power Limit (5725 MHz-5850 MHz) = 1W

Maximum Conducted Output Power

Test place	Ise EMC Lab. No.7 Shielded Room
Date	September 26, 2022
Temperature / Humidity	20 deg. C / 45 % RH
Engineer	Junya Okuno
Mode	Tx 11ac-40

11ac-40

Applied limit: 15.407, mobile and portable client device

Tested Frequency [MHz]	Power Meter Reading [dBm]	Cable Loss [dB]	Atten. Loss [dB]	Duty Factor [dB]	Antenna Gain [dBi]	Conducted Power				e.i.r.p.			
						Result		Limit [dBm]	Margin [dB]	Result		Limit [dBm]	Margin [dB]
						[dBm]	[mW]			[dBm]	[mW]		
5190	-9.13	0.80	10.13	2.62	3.79	4.42	2.77	23.97	19.55	8.21	6.62	29.97	21.76
5230	-9.44	0.80	10.13	2.62	3.79	4.11	2.58	23.97	19.86	7.90	6.17	29.97	22.07
5755	-9.14	0.80	10.14	2.62	3.34	4.42	2.77	30.00	25.58	7.76	5.97	36.00	28.24
5795	-8.90	0.80	10.14	2.62	3.34	4.66	2.92	30.00	25.34	8.00	6.31	36.00	28.00

Sample Calculation:

Conducted Power Result = Reading + Cable Loss (including the cable(s) customer supplied) + Atten. Loss + Duty Factor

e.i.r.p. Result = Conducted Power Result + Antenna Gain

Conducted Power Limit (5725 MHz-5850 MHz) = 1W

Maximum Conducted Output Power

Test place	Ise EMC Lab. No.7 Shielded Room
Date	September 26, 2022
Temperature / Humidity	20 deg. C / 45 % RH
Engineer	Junya Okuno
Mode	Tx 11ac-80

11ac-80

Applied limit: 15.407, mobile and portable client device

Tested Frequency [MHz]	Power Meter Reading [dBm]	Cable Loss [dB]	Atten. Loss [dB]	Duty Factor [dB]	Antenna Gain [dBi]	Conducted Power				e.i.r.p.			
						Result		Limit	Margin	Result		Limit	Margin
						[dBm]	[mW]	[dBm]	[dB]	[dBm]	[mW]	[dBm]	[dB]
5210	-10.44	0.80	10.13	3.84	3.79	4.33	2.71	23.97	19.64	8.12	6.49	29.97	21.85
5775	-10.61	0.80	10.14	3.84	3.34	4.17	2.61	30.00	25.83	7.51	5.64	36.00	28.49

Sample Calculation:

Conducted Power Result = Reading + Cable Loss (including the cable(s) customer supplied) + Atten. Loss + Duty Factor

e.i.r.p. Result = Conducted Power Result + Antenna Gain

Conducted Power Limit (5725 MHz-5850 MHz) = 1W

Maximum Conducted Output Power Worst data rate check

Test place Ise EMC Lab. No.7 Shielded Room
Date September 26, 2022
Temperature / Humidity 20 deg. C / 45 % RH
Engineer Junya Okuno
Mode Tx

5745 MHz

Mode	Rate Mbps	Reading (burst average) [dBm]	Remarks
11a	6	-6.27	
	9	-6.15	
	12	-6.15	
	18	-6.12	
	24	-5.72	
	36	-5.70	
	48	-5.66	
	54	-5.63	*

* Worst rate

This test was conducted by the use of Gate function.

All comparison were carried out on same frequency and measurement factors.

5745 MHz

Mode	MCS Number	Reading (burst average) Long GI [dBm]	Reading (burst average) Short GI [dB]	Remarks
11n-20	0	-6.29	-	
	1	-6.20	-	
	2	-6.19	-	
	3	-5.76	-	
	4	-5.70	-	
	5	-5.55	-	
	6	-5.50	-5.60	* (Long GI)
	7	-5.70	-	

* Worst rate

This test was conducted by the use of Gate function.

All comparison were carried out on same frequency and measurement factors.

5745 MHz

Mode	MCS Number	Reading (burst average) Long GI [dBm]	Reading (burst average) Short GI [dB]	Remarks
11ac-20	0	-6.16	-	
	1	-6.13	-	
	2	-6.11	-	
	3	-5.70	-	
	4	-5.57	-	
	5	-5.42	-	
	6	-5.40	-5.50	* (Long GI)
	7	-5.70	-	
	8	-5.68	-	

* Worst rate

This test was conducted by the use of Gate function.

All comparison were carried out on same frequency and measurement factors.

Maximum Conducted Output Power
Worst data rate check

Test place	Ise EMC Lab. No.7 Shielded Room
Date	September 26, 2022
Temperature / Humidity	20 deg. C / 45 % RH
Engineer	Junya Okuno
Mode	Tx

5755 MHz

Mode	MCS Number	Reading (burst average) Long GI [dBm]	Reading (burst average) Short GI [dB]	Remarks
11n-40	0	-6.22	-	
	1	-6.20	-	
	2	-6.14	-	
	3	-6.14	-	
	4	-5.94	-	
	5	-5.91	-	
	6	-5.89	-5.94	* (Long GI)
	7	-5.93	-	

* Worst rate

This test was conducted by the use of Gate function.
All comparison were carried out on same frequency and measurement factors.

5755 MHz

Mode	MCS Number	Reading (burst average) Long GI [dBm]	Reading (burst average) Short GI [dB]	Remarks
11ac-40	0	-6.19	-	
	1	-6.14	-	
	2	-6.05	-	
	3	-6.01	-	
	4	-5.92	-	
	5	-5.86	-	
	6	-5.75	-5.80	* (Long GI)
	7	-5.89	-	
	8	-5.82	-	
	9	-6.04	-	

* Worst rate

This test was conducted by the use of Gate function.
All comparison were carried out on same frequency and measurement factors.

Maximum Conducted Output Power
Worst data rate check

Test place Ise EMC Lab. No.7 Shielded Room
Date September 26, 2022
Temperature / Humidity 20 deg. C / 45 % RH
Engineer Junya Okuno
Mode Tx

5775 MHz

Mode	MCS Number	Reading (burst average) Long GI [dBm]	Reading (burst average) Short GI [dB]	Remarks
11ac-80	0	-6.42	-	
	1	-6.29	-	
	2	-6.21	-	
	3	-6.11	-	
	4	-6.28	-	
	5	-6.10	-	
	6	-6.16	-	
	7	-6.07	-	
	8	-6.03	-	
	9	-6.01	-6.03	* (Long GI)

* Worst rate

This test was conducted by the use of Gate function.

All comparison were carried out on same frequency and measurement factors.

Average Output Power
(Reference data for RF Exposure)

Test place	Ise EMC Lab. No.7 Shielded Room
Date	September 26, 2022
Temperature / Humidity	20 deg. C / 45 % RH
Engineer	Junya Okuno
Mode	Tx 11a

Tested Frequency [MHz]	Power Meter Reading [dBm]	Cable Loss [dB]	Atten. Loss [dB]	Result (Timed average)		Duty factor [dB]	Result (Burst power average)	
				[dBm]	[mW]		[dBm]	[mW]
5180	-6.61	0.80	10.13	4.32	2.70	0.28	4.60	2.88
5220	-7.05	0.80	10.13	3.88	2.44	0.28	4.16	2.61
5240	-7.15	0.80	10.13	3.78	2.39	0.28	4.06	2.55
5745	-7.08	0.80	10.14	3.86	2.43	0.28	4.14	2.59
5785	-6.98	0.80	10.14	3.96	2.49	0.28	4.24	2.65
5805	-6.85	0.80	10.14	4.09	2.56	0.28	4.37	2.74

Sample Calculation:

Result (Timed average) = Reading + Cable Loss (including the cable(s) customer supplied) + Atten. Loss

Result (Burst power average) = Time average + Duty factor

The average output power was measured with the lowest order modulation and lowest data rate configuration in each IEEE 802.11 mode based on KDB 248227 D01.

Average Output Power
(Reference data for RF Exposure)

Test place	Ise EMC Lab. No.7 Shielded Room
Date	September 26, 2022
Temperature / Humidity	20 deg. C / 45 % RH
Engineer	Junya Okuno
Mode	Tx 11n-20

Tested Frequency [MHz]	Power Meter Reading [dBm]	Cable Loss [dB]	Atten. Loss [dB]	Result (Timed average)		Duty factor [dB]	Result (Burst power average)	
				[dBm]	[mW]		[dBm]	[mW]
5180	-6.67	0.80	10.13	4.26	2.67	0.30	4.56	2.86
5220	-7.04	0.80	10.13	3.89	2.45	0.30	4.19	2.62
5240	-7.19	0.80	10.13	3.74	2.37	0.30	4.04	2.54
5745	-7.20	0.80	10.14	3.74	2.37	0.30	4.04	2.54
5785	-6.95	0.80	10.14	3.99	2.51	0.30	4.29	2.69
5805	-6.81	0.80	10.14	4.13	2.59	0.30	4.43	2.77

Sample Calculation:

Result (Timed average) = Reading + Cable Loss (including the cable(s) customer supplied) + Atten. Loss

Result (Burst power average) = Time average + Duty factor

The average output power was measured with the lowest order modulation and lowest data rate configuration in each IEEE 802.11 mode based on KDB 248227 D01.

Average Output Power
(Reference data for RF Exposure)

Test place	Ise EMC Lab. No.7 Shielded Room
Date	September 26, 2022
Temperature / Humidity	20 deg. C / 45 % RH
Engineer	Junya Okuno
Mode	Tx 11ac-20

Tested Frequency [MHz]	Power Meter Reading [dBm]	Cable Loss [dB]	Atten. Loss [dB]	Result (Timed average)		Duty factor [dB]	Result (Burst power average)	
				[dBm]	[mW]		[dBm]	[mW]
5180	-6.70	0.80	10.13	4.23	2.65	0.30	4.53	2.84
5220	-7.05	0.80	10.13	3.88	2.44	0.30	4.18	2.62
5240	-7.21	0.80	10.13	3.72	2.36	0.30	4.02	2.52
5745	-7.27	0.80	10.14	3.67	2.33	0.30	3.97	2.49
5785	-6.96	0.80	10.14	3.98	2.50	0.30	4.28	2.68
5805	-6.79	0.80	10.14	4.15	2.60	0.30	4.45	2.79

Sample Calculation:

Result (Timed average) = Reading + Cable Loss (including the cable(s) customer supplied) + Atten. Loss

Result (Burst power average) = Time average + Duty factor

The average output power was measured with the lowest order modulation and lowest data rate configuration in each IEEE 802.11 mode based on KDB 248227 D01.

Average Output Power
(Reference data for RF Exposure)

Test place Ise EMC Lab. No.7 Shielded Room
Date September 26, 2022
Temperature / Humidity 20 deg. C / 45 % RH
Engineer Junya Okuno
Mode Tx 11n-40

Tested Frequency [MHz]	Power Meter Reading [dBm]	Cable Loss [dB]	Atten. Loss [dB]	Result (Timed average)		Duty factor [dB]	Result (Burst power average)	
				[dBm]	[mW]		[dBm]	[mW]
5190	-7.27	0.80	10.13	3.66	2.32	0.58	4.24	2.65
5230	-7.66	0.80	10.13	3.27	2.12	0.58	3.85	2.43
5755	-7.27	0.80	10.14	3.67	2.33	0.58	4.25	2.66
5795	-6.97	0.80	10.14	3.97	2.49	0.58	4.55	2.85

Sample Calculation:

Result (Timed average) = Reading + Cable Loss (including the cable(s) customer supplied) + Atten. Loss

Result (Burst power average) = Time average + Duty factor

The average output power was measured with the lowest order modulation and lowest data rate configuration in each IEEE 802.11 mode based on KDB 248227 D01.

Average Output Power
(Reference data for RF Exposure)

Test place Ise EMC Lab. No.7 Shielded Room
Date September 26, 2022
Temperature / Humidity 20 deg. C / 45 % RH
Engineer Junya Okuno
Mode Tx 11ac-40

Tested Frequency [MHz]	Power Meter Reading [dBm]	Cable Loss [dB]	Atten. Loss [dB]	Result (Timed average)		Duty factor [dB]	Result (Burst power average)	
				[dBm]	[mW]		[dBm]	[mW]
5190	-7.30	0.80	10.13	3.63	2.31	0.58	4.21	2.64
5230	-7.46	0.80	10.13	3.47	2.22	0.58	4.05	2.54
5755	-7.20	0.80	10.14	3.74	2.37	0.58	4.32	2.70
5795	-7.00	0.80	10.14	3.94	2.48	0.58	4.52	2.83

Sample Calculation:

Result (Timed average) = Reading + Cable Loss (including the cable(s) customer supplied) + Atten. Loss

Result (Burst power average) = Time average + Duty factor

The average output power was measured with the lowest order modulation and lowest data rate configuration in each IEEE 802.11 mode based on KDB 248227 D01.

Average Output Power
(Reference data for RF Exposure)

Test place	Ise EMC Lab. No.7 Shielded Room
Date	September 26, 2022
Temperature / Humidity	20 deg. C / 45 % RH
Engineer	Junya Okuno
Mode	Tx 11ac-80

Tested Frequency [MHz]	Power Meter Reading [dBm]	Cable Loss [dB]	Atten. Loss [dB]	Result (Timed average)		Duty factor [dB]	Result (Burst power average)	
				[dBm]	[mW]		[dBm]	[mW]
5210	-7.81	0.80	10.13	3.12	2.05	1.09	4.21	2.64
5775	-7.97	0.80	10.14	2.97	1.98	1.09	4.06	2.55

Sample Calculation:

Result (Timed average) = Reading + Cable Loss (including the cable(s) customer supplied) + Atten. Loss

Result (Burst power average) = Time average + Duty factor

The average output power was measured with the lowest order modulation and lowest data rate configuration in each IEEE 802.11 mode based on KDB 248227 D01.

Burst rate confirmation

Test place Ise EMC Lab. No.7 Shielded Room
Date September 27, 2022
Temperature / Humidity 25 deg. C / 45 % RH
Engineer Junya Okuno
Mode Tx

11a 54 Mbps

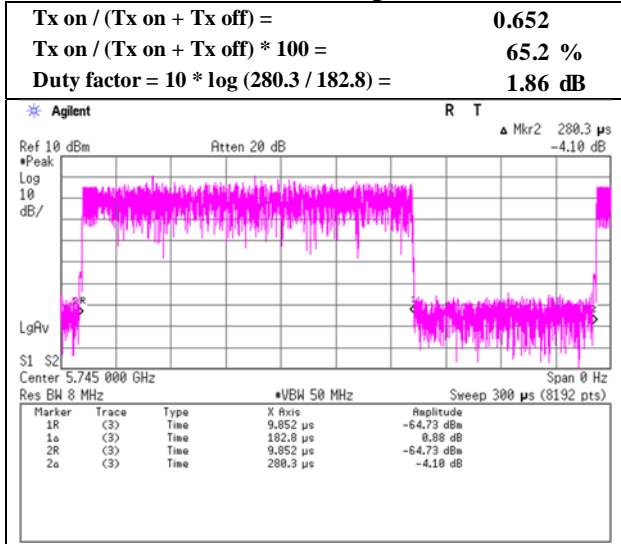

11n-20 MCS 6 (Long GI)

11ac-20 MCS 6 (Long GI)

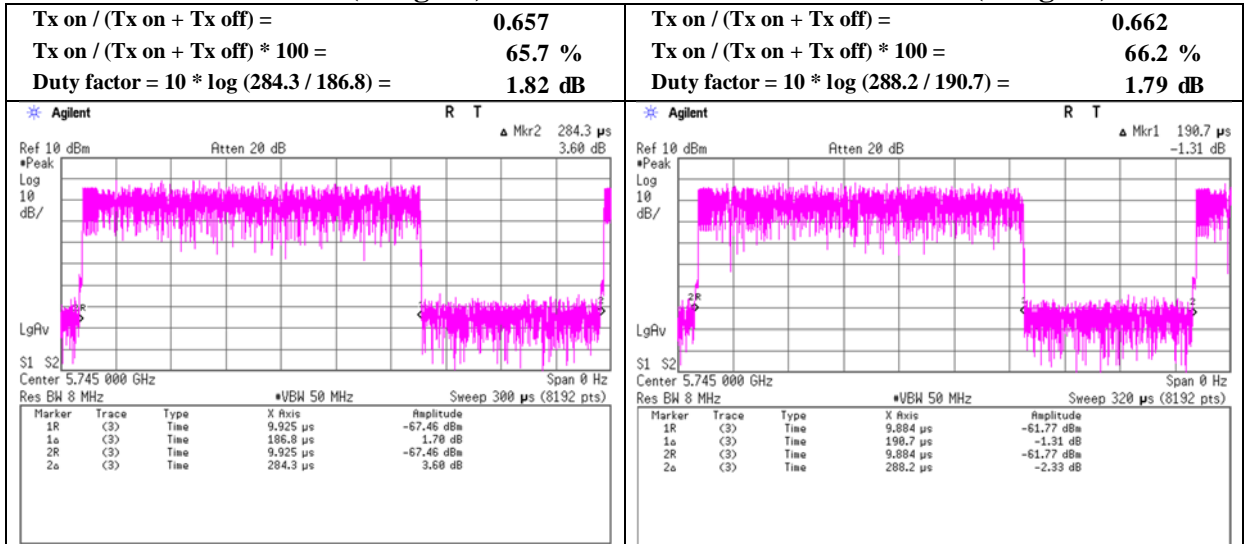

Burst rate confirmation

Test place Ise EMC Lab. No.7 Shielded Room
 Date September 27, 2022
 Temperature / Humidity 25 deg. C / 45 % RH
 Engineer Junya Okuno
 Mode Tx

11n-40 MCS 6 (Long GI)

11ac-40 MCS 6 (Long GI)

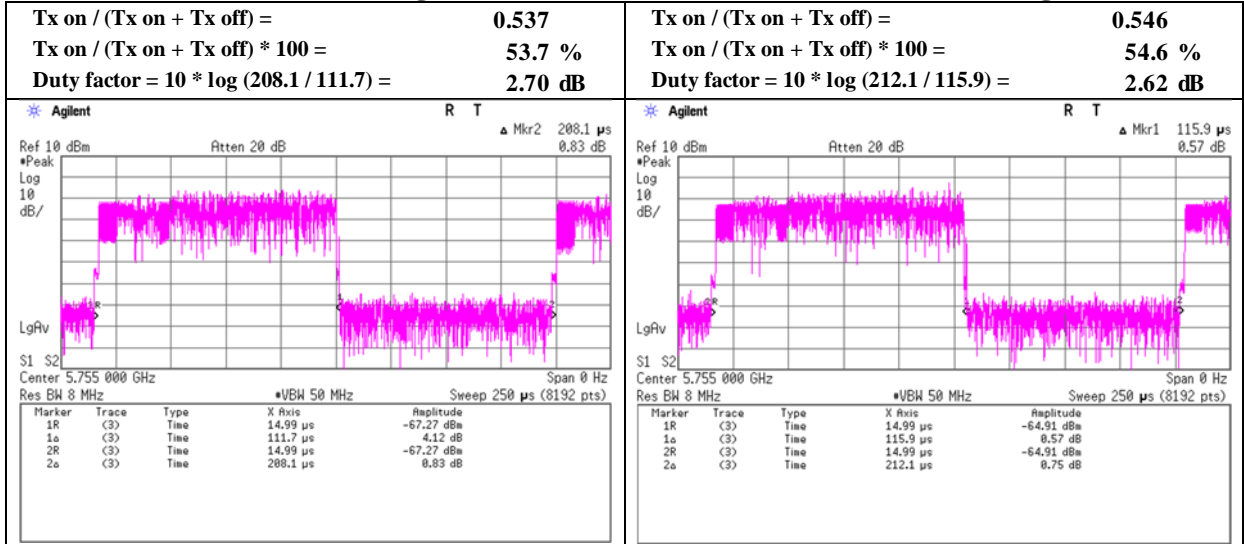

11ac-80 MCS 9 (Long GI)

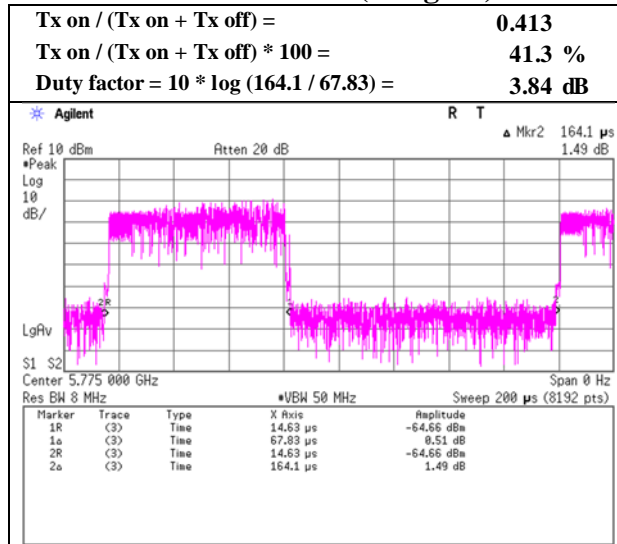

Burst rate confirmation

Test place Ise EMC Lab. No.7 Shielded Room
Date September 27, 2022
Temperature / Humidity 25 deg. C / 45 % RH
Engineer Junya Okuno
Mode Tx

11a 6 Mbps

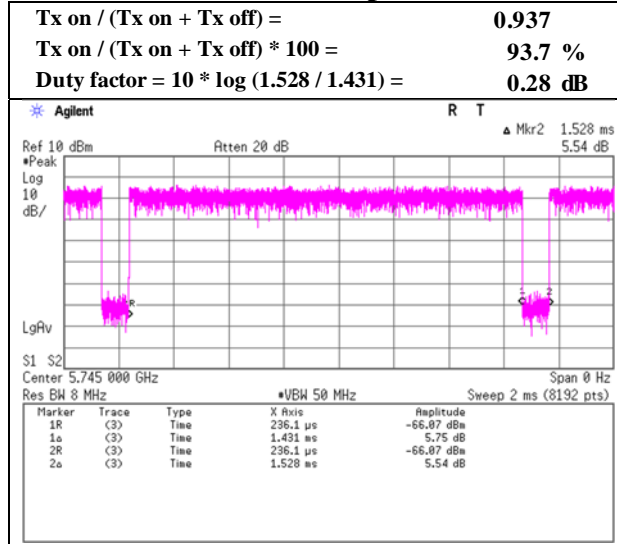

11n-20 MCS 0 (Long GI)

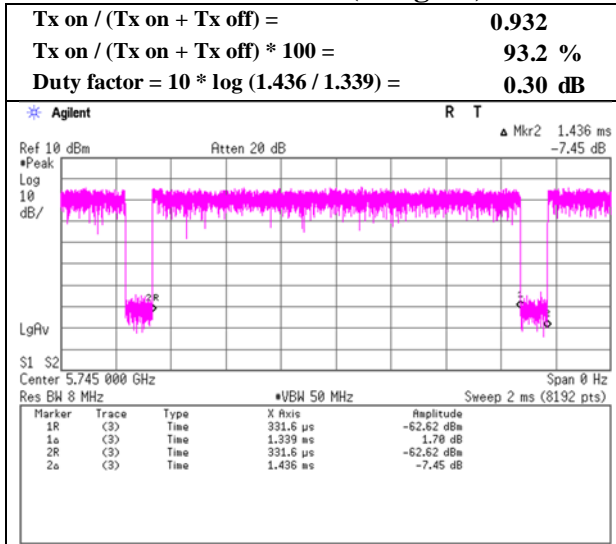

11ac-20 MCS 0 (Long GI)

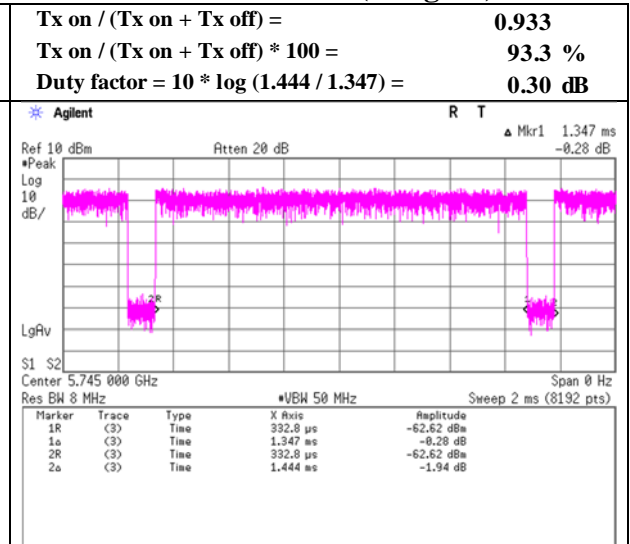

Burst rate confirmation

Test place Ise EMC Lab. No.7 Shielded Room
Date September 27, 2022
Temperature / Humidity 25 deg. C / 45 % RH
Engineer Junya Okuno
Mode Tx

11n-40 MCS 0 (Long GI)

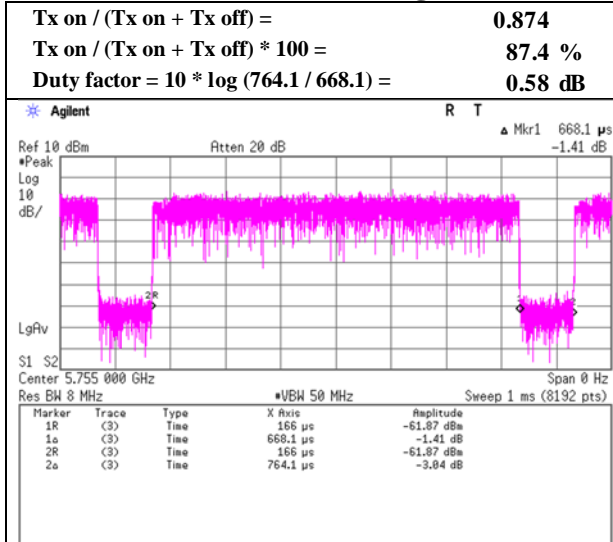

11ac-40 MCS 0 (Long GI)

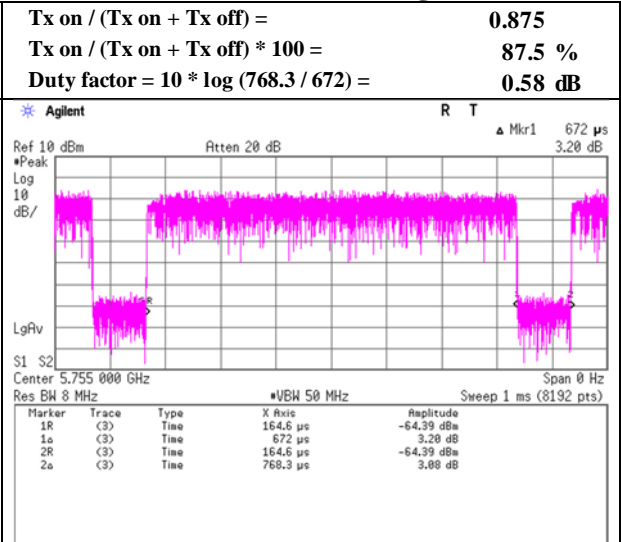

11ac-80 MCS 0 (Long GI)

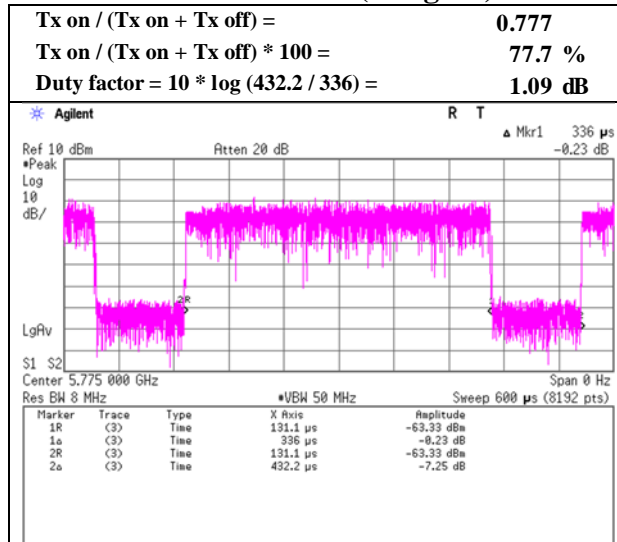

Maximum Power Spectral Density

Test place	Ise EMC Lab. No.4 Measurement Room
Date	October 11, 2022
Temperature / Humidity	23 deg. C / 55 % RH
Engineer	Takumi Nishida
Mode	Tx 11a

Applied limit: 15.407, mobile and portable client device

Tested Frequency [MHz]	PSD Reading [dBm /MHz]	Cable Loss [dB]	Atten. Loss [dB]	Duty Factor [dB]	Antenna Gain [dBi]	RBW Correction Factor [dB]	PSD (Conducted)			PSD (e.i.r.p.)		
							Result [dBm /MHz]	Limit [dBm /MHz]	Margin [dB]	Result [dBm /MHz]	Limit [dBm /MHz]	Margin [dB]
5180	-19.65	1.34	10.13	1.86	3.79	0.00	-6.32	11.00	17.32	-2.53	17.00	19.53
5220	-19.67	1.34	10.13	1.86	3.79	0.00	-6.34	11.00	17.34	-2.55	17.00	19.55
5240	-19.79	1.34	10.13	1.86	3.79	0.00	-6.46	11.00	17.46	-2.67	17.00	19.67
5745	-22.88	1.44	10.14	1.86	3.34	0.27	-9.17	30.00	39.17	-5.83	36.00	41.83
5785	-23.31	1.44	10.14	1.86	3.34	0.27	-9.60	30.00	39.60	-6.26	36.00	42.26
5805	-23.19	1.45	10.14	1.86	3.34	0.27	-9.47	30.00	39.47	-6.13	36.00	42.13

Sample Calculation:

PSD: Power Spectral Density

The PSD within 5725 MHz to 5825 MHz are based on any 500 kHz band.

RBW Correction Factor = $10 * \log(\text{Specified bandwidth} / \text{Measured bandwidth})$

PSD Result (Conducted) = Reading + Cable Loss (including the cable(s) customer supplied) + Atten. Loss + Duty Factor + RBW Correction Factor

PSD Result (e.i.r.p.) = Conducted PSD Result + Antenna Gain

Maximum Power Spectral Density

Test place	Ise EMC Lab. No.4 Measurement Room
Date	October 11, 2022
Temperature / Humidity	23 deg. C / 55 % RH
Engineer	Takumi Nishida
Mode	Tx 11n-20

Applied limit: 15.407, mobile and portable client device

Tested Frequency [MHz]	PSD Reading [dBm /MHz]	Cable Loss [dB]	Atten. Loss [dB]	Duty Factor [dB]	Antenna Gain [dBi]	RBW Correction Factor [dB]	PSD (Conducted)			PSD (e.i.r.p.)		
							Result [dBm /MHz]	Limit [dBm /MHz]	Margin [dB]	Result [dBm /MHz]	Limit [dBm /MHz]	Margin [dB]
5180	-19.81	1.34	10.13	1.82	3.79	0.00	-6.52	11.00	17.52	-2.73	17.00	19.73
5220	-20.22	1.34	10.13	1.82	3.79	0.00	-6.93	11.00	17.93	-3.14	17.00	20.14
5240	-20.15	1.34	10.13	1.82	3.79	0.00	-6.86	11.00	17.86	-3.07	17.00	20.07
5745	-23.52	1.44	10.14	1.82	3.34	0.27	-9.85	30.00	39.85	-6.51	36.00	42.51
5785	-23.83	1.44	10.14	1.82	3.34	0.27	-10.16	30.00	40.16	-6.82	36.00	42.82
5805	-23.53	1.45	10.14	1.82	3.34	0.27	-9.85	30.00	39.85	-6.51	36.00	42.51

Sample Calculation:

PSD: Power Spectral Density

The PSD within 5725 MHz to 5825 MHz are based on any 500 kHz band.

RBW Correction Factor = $10 * \log(\text{Specified bandwidth} / \text{Measured bandwidth})$

PSD Result (Conducted) = Reading + Cable Loss (including the cable(s) customer supplied) + Atten. Loss + Duty Factor + RBW Correction Factor

PSD Result (e.i.r.p.) = Conducted PSD Result + Antenna Gain

Maximum Power Spectral Density

Test place	Ise EMC Lab. No.4 Measurement Room
Date	October 11, 2022
Temperature / Humidity	23 deg. C / 55 % RH
Engineer	Takumi Nishida
Mode	Tx 11ac-20

Applied limit: 15.407, mobile and portable client device

Tested Frequency [MHz]	PSD Reading [dBm /MHz]	Cable Loss [dB]	Atten. Loss [dB]	Duty Factor [dB]	Antenna Gain [dBi]	RBW Correction Factor [dB]	PSD (Conducted)			PSD (e.i.r.p.)		
							Result [dBm /MHz]	Limit [dBm /MHz]	Margin [dB]	Result [dBm /MHz]	Limit [dBm /MHz]	Margin [dB]
5180	-19.67	1.34	10.13	1.79	3.79	0.00	-6.41	11.00	17.41	-2.62	17.00	19.62
5220	-20.12	1.34	10.13	1.79	3.79	0.00	-6.86	11.00	17.86	-3.07	17.00	20.07
5240	-19.95	1.34	10.13	1.79	3.79	0.00	-6.69	11.00	17.69	-2.90	17.00	19.90
5745	-23.64	1.44	10.14	1.79	3.34	0.27	-10.01	30.00	40.01	-6.67	36.00	42.67
5785	-23.82	1.44	10.14	1.79	3.34	0.27	-10.18	30.00	40.18	-6.84	36.00	42.84
5805	-23.38	1.45	10.14	1.79	3.34	0.27	-9.73	30.00	39.73	-6.39	36.00	42.39

Sample Calculation:

PSD: Power Spectral Density

The PSD within 5725 MHz to 5825 MHz are based on any 500 kHz band.

RBW Correction Factor = $10 * \log(\text{Specified bandwidth} / \text{Measured bandwidth})$

PSD Result (Conducted) = Reading + Cable Loss (including the cable(s) customer supplied) + Atten. Loss + Duty Factor + RBW Correction Factor

PSD Result (e.i.r.p.) = Conducted PSD Result + Antenna Gain

Maximum Power Spectral Density

Test place	Ise EMC Lab. No.4 Measurement Room
Date	October 11, 2022
Temperature / Humidity	23 deg. C / 55 % RH
Engineer	Takumi Nishida
Mode	Tx 11n-40

Applied limit: 15.407, mobile and portable client device

Tested Frequency [MHz]	PSD Reading [dBm /MHz]	Cable Loss [dB]	Atten. Loss [dB]	Duty Factor [dB]	Antenna Gain [dBi]	RBW Correction Factor [dB]	PSD (Conducted)			PSD (e.i.r.p.)		
							Result [dBm /MHz]	Limit [dBm /MHz]	Margin [dB]	Result [dBm /MHz]	Limit [dBm /MHz]	Margin [dB]
5190	-23.94	1.34	10.13	2.70	3.79	0.00	-9.77	11.00	20.77	-5.98	17.00	22.98
5230	-24.49	1.34	10.13	2.70	3.79	0.00	-10.32	11.00	21.32	-6.53	17.00	23.53
5755	-27.37	1.44	10.14	2.70	3.34	0.27	-12.82	30.00	42.82	-9.48	36.00	45.48
5795	-27.14	1.45	10.14	2.70	3.34	0.27	-12.58	30.00	42.58	-9.24	36.00	45.24

Sample Calculation:

PSD: Power Spectral Density

The PSD within 5725 MHz to 5825 MHz are based on any 500 kHz band.

RBW Correction Factor = $10 * \log(\text{Specified bandwidth} / \text{Measured bandwidth})$

PSD Result (Conducted) = Reading + Cable Loss (including the cable(s) customer supplied) + Atten. Loss + Duty Factor + RBW Correction Factor

PSD Result (e.i.r.p.) = Conducted PSD Result + Antenna Gain

Maximum Power Spectral Density

Test place	Ise EMC Lab. No.4 Measurement Room
Date	October 11, 2022
Temperature / Humidity	23 deg. C / 55 % RH
Engineer	Takumi Nishida
Mode	Tx 11ac-40

Applied limit: 15.407, mobile and portable client device

Tested Frequency [MHz]	PSD Reading [dBm /MHz]	Cable Loss [dB]	Atten. Loss [dB]	Duty Factor [dB]	Antenna Gain [dBi]	RBW Correction Factor [dB]	PSD (Conducted)			PSD (e.i.r.p.)		
							Result [dBm /MHz]	Limit [dBm /MHz]	Margin [dB]	Result [dBm /MHz]	Limit [dBm /MHz]	Margin [dB]
5190	-24.31	1.34	10.13	2.62	3.79	0.00	-10.22	11.00	21.22	-6.43	17.00	23.43
5230	-24.57	1.34	10.13	2.62	3.79	0.00	-10.48	11.00	21.48	-6.69	17.00	23.69
5755	-26.90	1.44	10.14	2.62	3.34	0.27	-12.43	30.00	42.43	-9.09	36.00	45.09
5795	-27.60	1.45	10.14	2.62	3.34	0.27	-13.12	30.00	43.12	-9.78	36.00	45.78

Sample Calculation:

PSD: Power Spectral Density

The PSD within 5725 MHz to 5825 MHz are based on any 500 kHz band.

RBW Correction Factor = $10 * \log(\text{Specified bandwidth} / \text{Measured bandwidth})$

PSD Result (Conducted) = Reading + Cable Loss (including the cable(s) customer supplied) + Atten. Loss + Duty Factor + RBW Correction Factor

PSD Result (e.i.r.p.) = Conducted PSD Result + Antenna Gain

Maximum Power Spectral Density

Test place Ise EMC Lab. No.4 Measurement Room
Date October 11, 2022
Temperature / Humidity 23 deg. C / 55 % RH
Engineer Takumi Nishida
Mode Tx 11ac-80

Applied limit: 15.407, mobile and portable client device

Tested Frequency [MHz]	PSD Reading [dBm /MHz]	Cable Loss [dB]	Atten. Loss [dB]	Duty Factor [dB]	Antenna Gain [dBi]	RBW Correction Factor [dB]	PSD (Conducted)			PSD (e.i.r.p.)		
							Result [dBm /MHz]	Limit [dBm /MHz]	Margin [dB]	Result [dBm /MHz]	Limit [dBm /MHz]	Margin [dB]
5210	-28.05	1.34	10.13	3.84	3.79	0.00	-12.74	11.00	23.74	-8.95	17.00	25.95
5775	-31.02	1.45	10.14	3.84	3.34	0.27	-15.32	30.00	45.32	-11.98	36.00	47.98

Sample Calculation:

PSD: Power Spectral Density

The PSD within 5725 MHz to 5825 MHz are based on any 500 kHz band.

RBW Correction Factor = $10 * \log(\text{Specified bandwidth} / \text{Measured bandwidth})$

PSD Result (Conducted) = Reading + Cable Loss (including the cable(s) customer supplied) + Atten. Loss + Duty Factor + RBW Correction Factor

PSD Result (e.i.r.p.) = Conducted PSD Result + Antenna Gain

Maximum Power Spectral Density

Test place	Ise EMC Lab. No.4 Measurement Room
Date	October 11, 2022
Temperature / Humidity	23 deg. C / 55 % RH
Engineer	Takumi Nishida
Mode	Tx 11a

11a

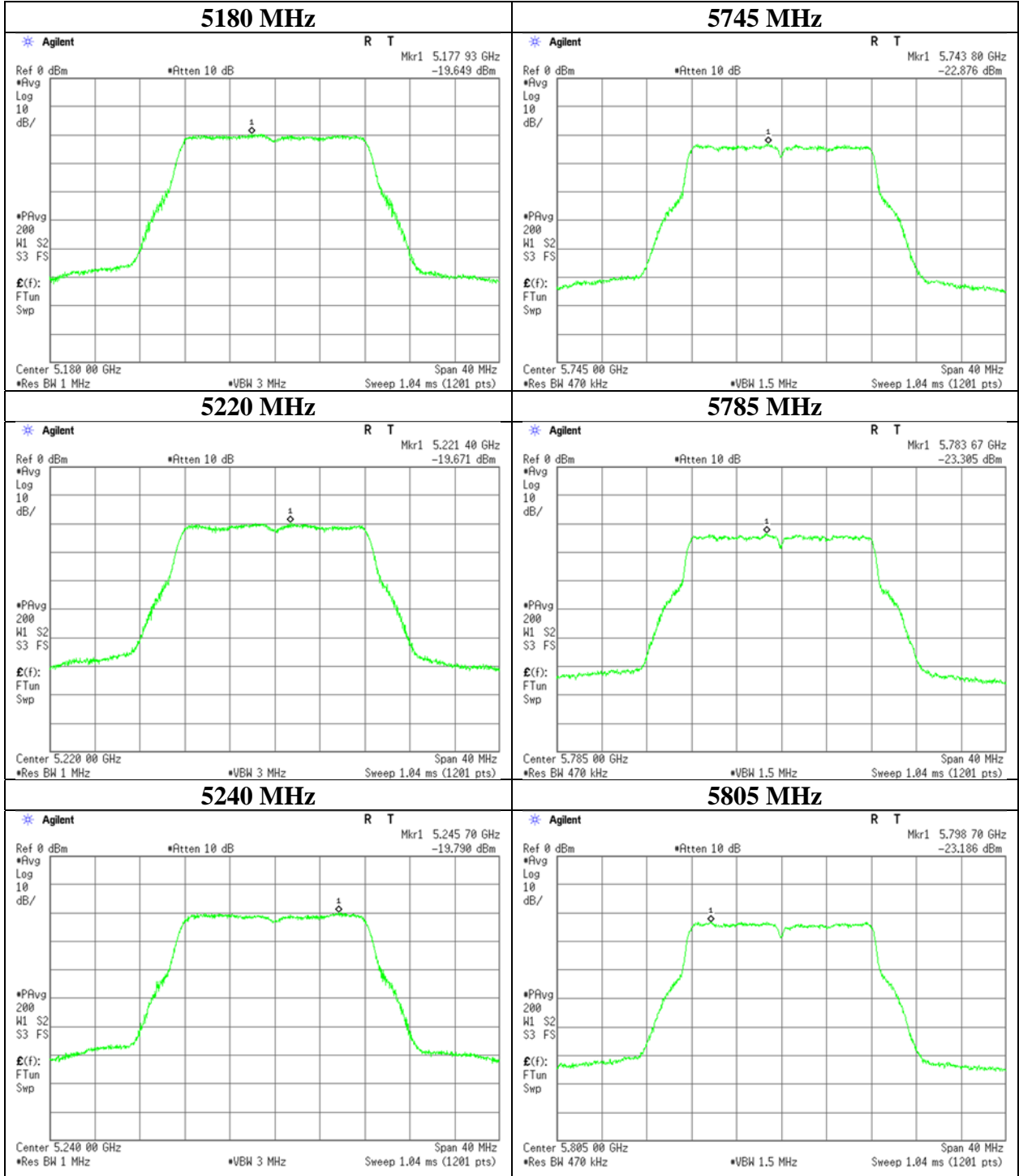

Maximum Power Spectral Density

Test place	Ise EMC Lab. No.4 Measurement Room
Date	October 11, 2022
Temperature / Humidity	23 deg. C / 55 % RH
Engineer	Takumi Nishida
Mode	Tx 11n-20

11n-20

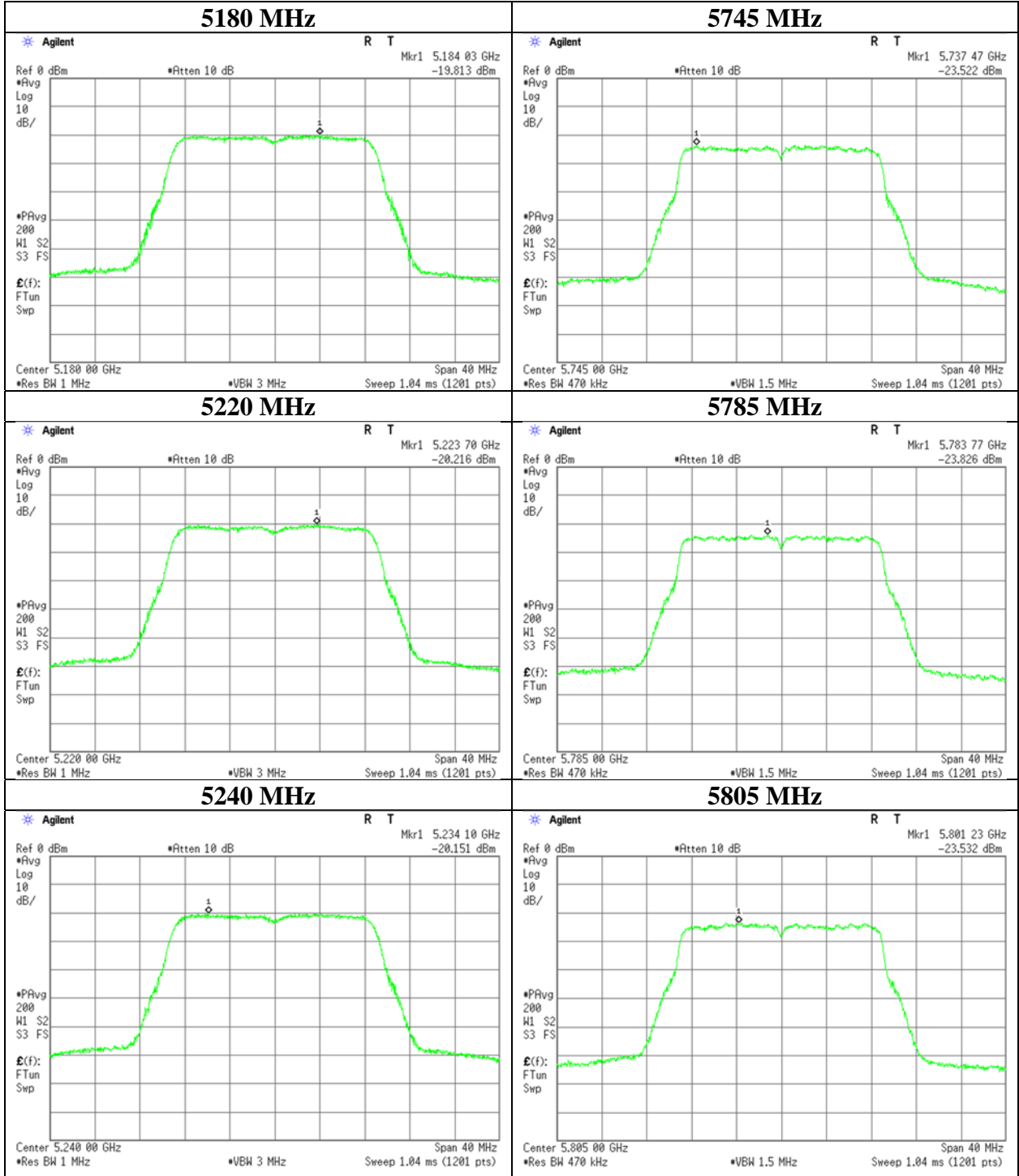

Maximum Power Spectral Density

Test place Ise EMC Lab. No.4 Measurement Room
Date October 11, 2022
Temperature / Humidity 23 deg. C / 55 % RH
Engineer Takumi Nishida
Mode Tx 11ac-20

11ac-20

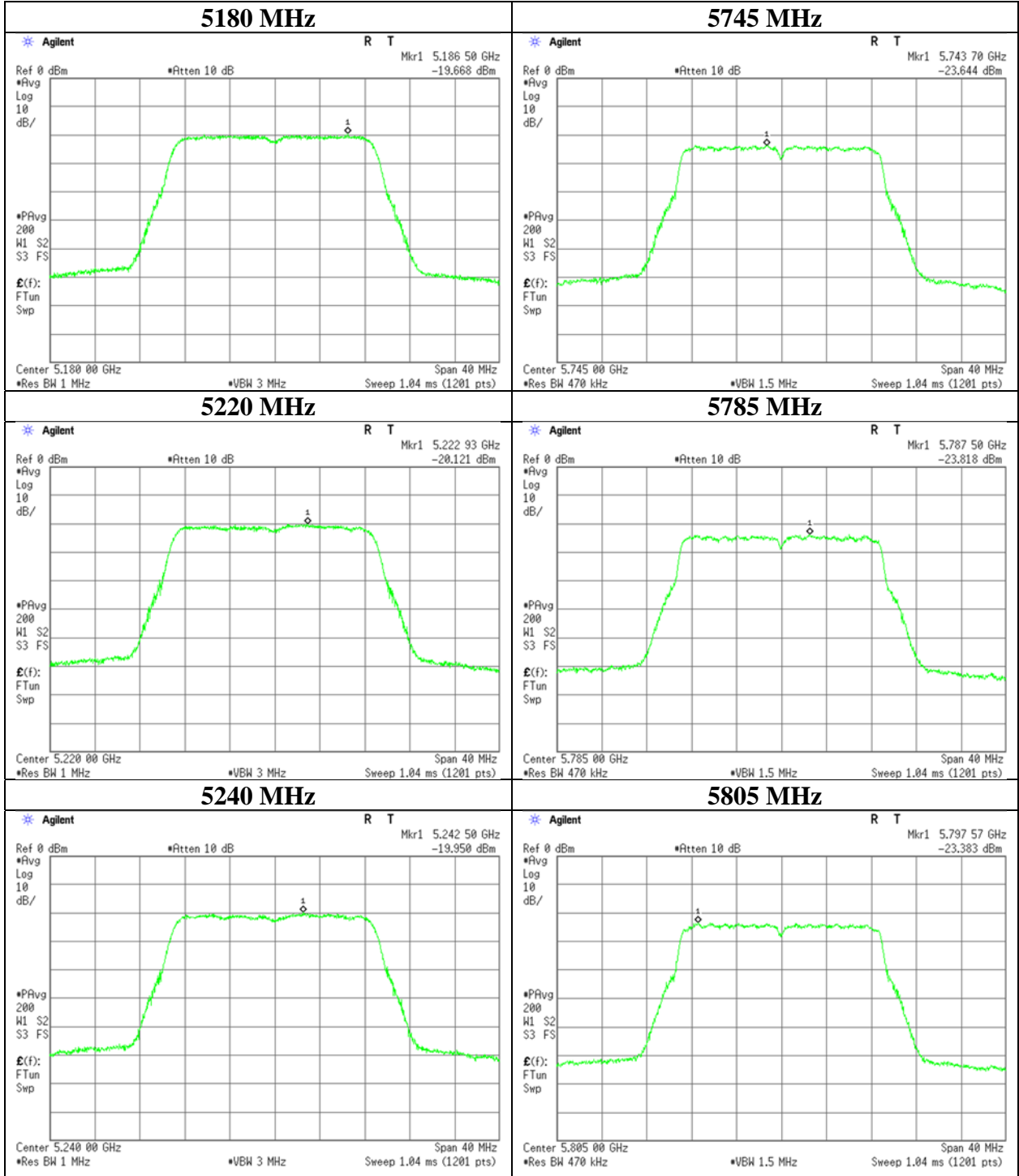

Maximum Power Spectral Density

Test place	Ise EMC Lab. No.4 Measurement Room
Date	October 11, 2022
Temperature / Humidity	23 deg. C / 55 % RH
Engineer	Takumi Nishida
Mode	Tx 11n-40

11n-40

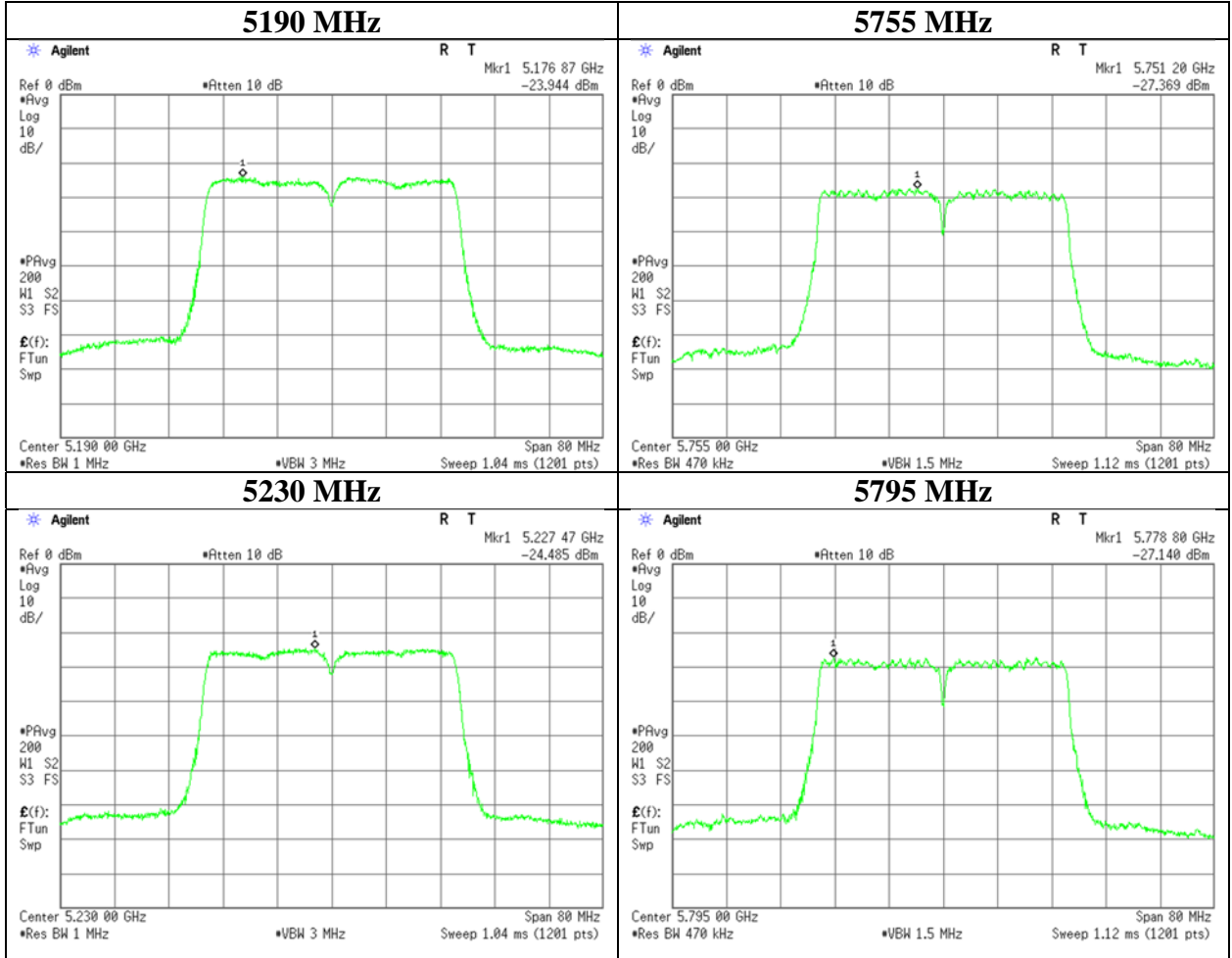

Maximum Power Spectral Density

Test place	Ise EMC Lab. No.4 Measurement Room
Date	October 11, 2022
Temperature / Humidity	23 deg. C / 55 % RH
Engineer	Takumi Nishida
Mode	Tx 11ac-40

11ac-40

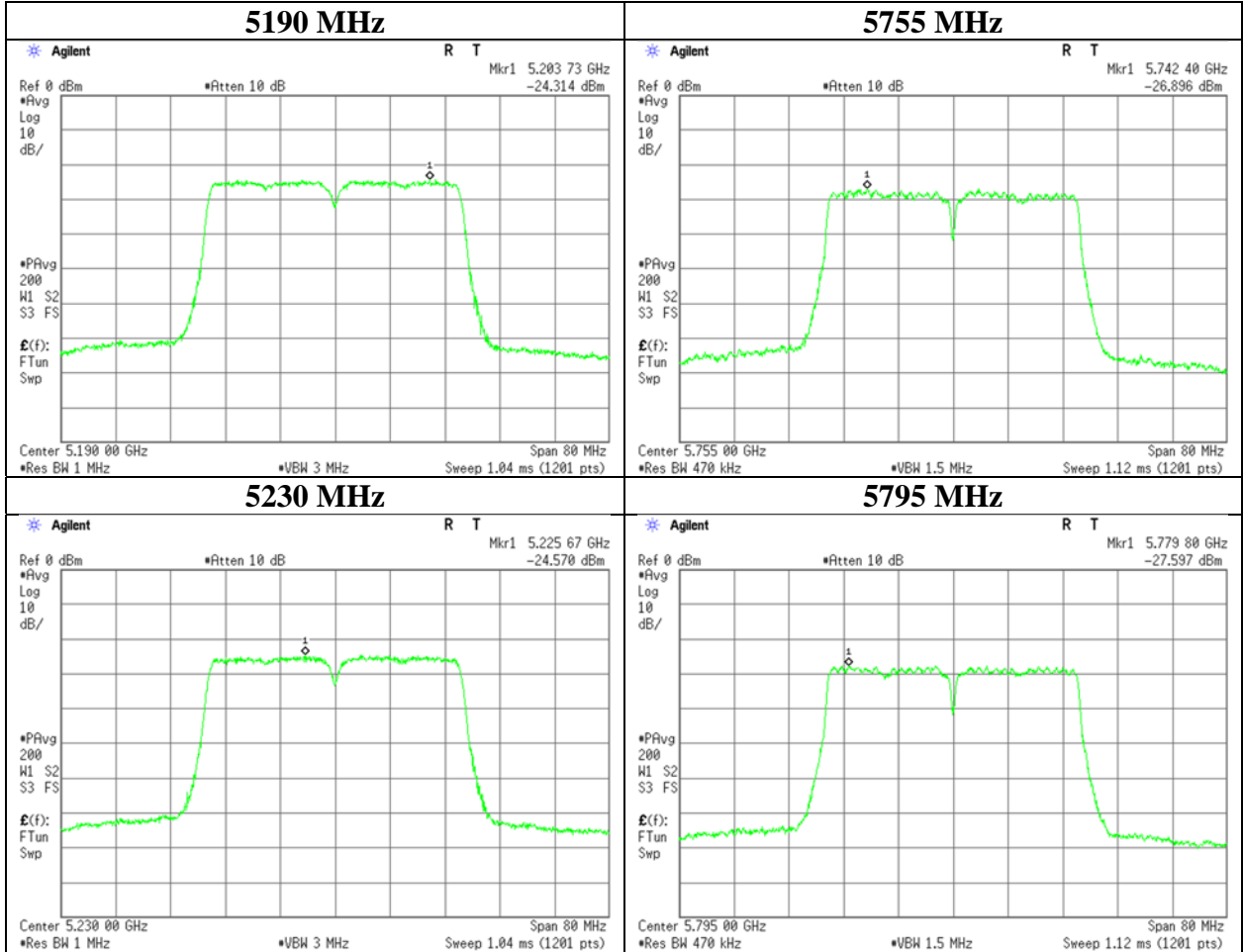

Maximum Power Spectral Density

Test place	Ise EMC Lab. No.4 Measurement Room
Date	October 11, 2022
Temperature / Humidity	23 deg. C / 55 % RH
Engineer	Takumi Nishida
Mode	Tx 11ac-80

11ac-80

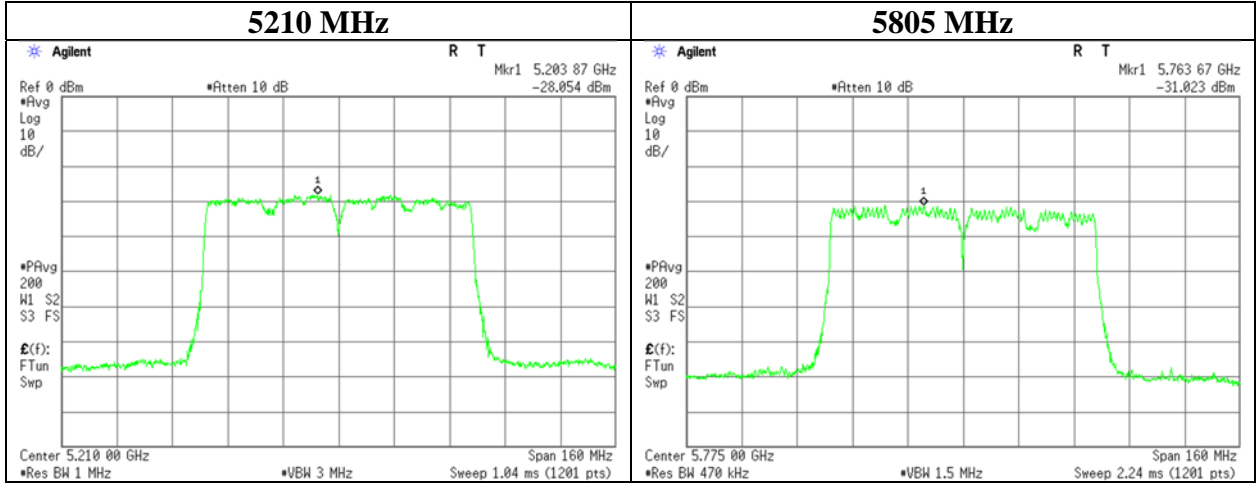

Radiated Spurious Emission

Test place	Ise EMC Lab.	
Semi Anechoic Chamber	No.2	No.2
Date	September 30, 2022	October 5, 2022
Temperature / Humidity	22 deg. C / 55 % RH	24 deg. C / 50 % RH
Engineer	Keiya Ido	Hiroyuki Furutaka
	(1 GHz - 10 GHz)	(10 GHz - 40 GHz)
Mode	Tx 11a 5180 MHz	

Polarity [Hori/Vert]	Frequency [MHz]	Reading (QP / PK) [dBuV]	Reading (AV) [dBuV]	Ant. Factor [dB/m]	Loss [dB]	Gain [dB]	Duty Factor [dB]	Result (QP / PK) [dBuV/m]	Result (AV) [dBuV/m]	Limit (QP / PK) [dBuV/m]	Limit (AV) [dBuV/m]	Margin (QP / PK) [dB]	Margin (AV) [dB]	Remark
Hori.	5150.0	47.4	37.2	31.7	5.4	34.1	1.9	50.5	42.2	73.9	53.9	23.4	11.7	*1)
Hori.	10360.0	44.7	-	39.2	-2.5	34.5	-	47.0	-	68.2	-	21.3	-	Floor noise
Hori.	15540.0	45.7	36.3	37.4	-0.8	33.5	-	48.9	39.5	73.9	53.9	25.0	14.4	Floor noise
Vert.	5150.0	47.2	34.4	31.7	5.4	34.1	1.9	50.2	39.4	73.9	53.9	23.7	14.6	*1)
Vert.	10360.0	44.5	-	39.2	-2.5	34.5	-	46.8	-	68.2	-	21.5	-	Floor noise
Vert.	15540.0	45.6	36.2	37.4	-0.8	33.5	-	48.8	39.4	73.9	53.9	25.1	14.5	Floor noise

Result (QP / PK) = Reading + Ant Factor + Loss (Cable+Attenuator+Filter+Distance factor(above 1 GHz)) - Gain(Amplifier)

Result (AV)= Reading + Ant Factor + Loss (Cable+Attenuator+Filter+Distance factor(above 1 GHz)) - Gain(Amplifier) + Duty factor

*Other frequency noises omitted in this report were not seen or had enough margin (more than 20 dB).

*QP detector was used up to 1GHz.

*1) Not Out of Band emission(Leakage Power)

Distance factor:	1 GHz - 10 GHz	20log(3.6 m / 3.0 m) = 1.59 dB
	10 GHz - 40 GHz	20log(1.0 m / 3.0 m) = -9.5 dB

Radiated Spurious Emission

Test place Ise EMC Lab.
Semi Anechoic Chamber No.2
Date September 30, 2022
Temperature / Humidity 22 deg. C / 55 % RH
Engineer Keiya Ido
 (1 GHz - 10 GHz)
Mode Tx 11a 5180 MHz

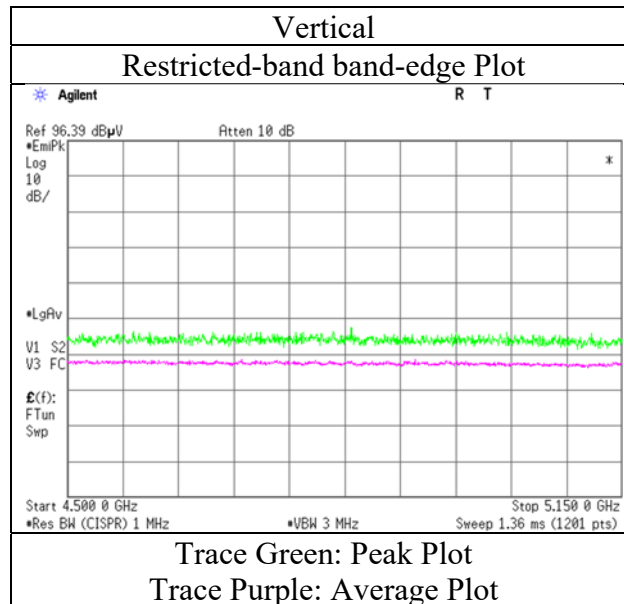
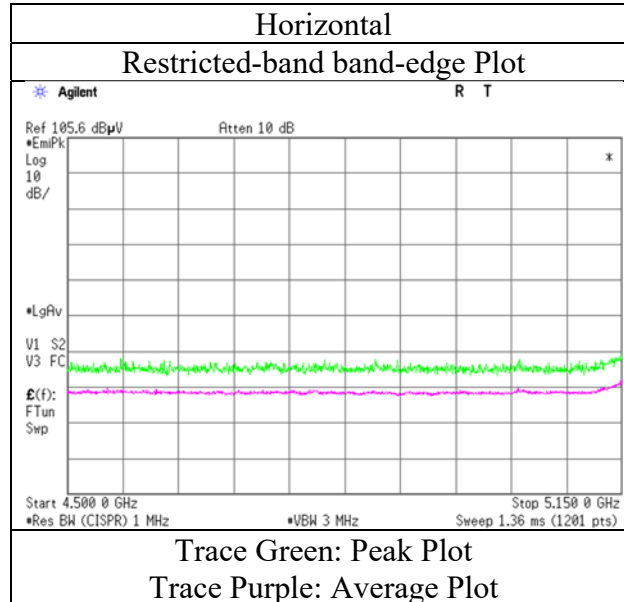

* The measurement was conducted for a sufficiently long enough time to detect any possible spurious emissions.
Final result of restricted band edge was shown in tabular data.

Radiated Spurious Emission

Test place	Ise EMC Lab.	
Semi Anechoic Chamber	No.2	No.2
Date	September 30, 2022	October 5, 2022
Temperature / Humidity	22 deg. C / 55 % RH	24 deg. C / 50 % RH
Engineer	Keiya Ido	Hiroyuki Furutaka
	(1 GHz - 10 GHz)	(10 GHz - 40 GHz)
Mode	Tx 11a 5220 MHz	

Polarity	Frequency	Reading (QP / PK)	Reading (AV)	Ant. Factor	Loss	Gain	Duty Factor	Result (QP / PK)	Result (AV)	Limit (QP / PK)	Limit (AV)	Margin (QP / PK)	Margin (AV)	Remark
[Hori/Vert]	[MHz]	[dBuV]	[dBuV]	[dB/m]	[dB]	[dB]	[dB]	[dBuV/m]	[dBuV/m]	[dBuV/m]	[dBuV/m]	[dB]	[dB]	
Hori.	10440.0	44.2	-	39.3	-2.4	34.4	-	46.6	-	68.2	-	21.6	-	Floor noise
Hori.	15660.0	45.7	36.9	37.3	-0.7	33.6	-	48.7	39.9	73.9	53.9	25.3	14.1	Floor noise
Vert.	10440.0	43.8	-	39.3	-2.4	34.4	-	46.2	-	68.2	-	22.0	-	Floor noise
Vert.	15660.0	45.5	35.6	37.3	-0.7	33.6	-	48.5	38.6	73.9	53.9	25.5	15.4	Floor noise

Result (QP / PK) = Reading + Ant Factor + Loss (Cable+Attenuator+Filter+Distance factor(above 1 GHz)) - Gain(Amplifier)

Result (AV)= Reading + Ant Factor + Loss (Cable+Attenuator+Filter+Distance factor(above 1 GHz)) - Gain(Amplifier) + Duty factor

*Other frequency noises omitted in this report were not seen or had enough margin (more than 20 dB).

*QP detector was used up to 1GHz.

Distance factor:	1 GHz - 10 GHz	20log(3.6 m / 3.0 m) = 1.59 dB
	10 GHz - 40 GHz	20log(1.0 m / 3.0 m) = -9.5 dB

Radiated Spurious Emission

Test place	Ise EMC Lab.	
Semi Anechoic Chamber	No.2	No.2
Date	September 30, 2022	October 5, 2022
Temperature / Humidity	22 deg. C / 55 % RH	24 deg. C / 50 % RH
Engineer	Keiya Ido	Hiroyuki Furutaka
	(1 GHz - 10 GHz)	(10 GHz - 40 GHz)
Mode	Tx 11a 5240 MHz	

Polarity [Hori/Vert]	Frequency [MHz]	Reading (QP / PK) [dBuV]	Reading (AV) [dBuV]	Ant. Factor [dB/m]	Loss [dB]	Gain [dB]	Duty Factor [dB]	Result (QP / PK) [dBuV/m]	Result (AV) [dBuV/m]	Limit (QP / PK) [dBuV/m]	Limit (AV) [dBuV/m]	Margin (QP / PK) [dB]	Margin (AV) [dB]	Remark
Hori.	5350.0	43.9	35.1	31.6	5.5	34.0	1.9	47.0	40.0	73.9	53.9	26.9	13.9	*1)
Hori.	10480.0	44.1	-	39.3	-2.4	34.4	-	46.5	-	68.2	-	21.7	-	Floor noise
Hori.	15720.0	45.6	36.8	37.2	-0.7	33.6	-	48.4	39.6	73.9	53.9	25.5	14.3	Floor noise
Vert.	5350.0	43.8	34.9	31.6	5.5	34.0	1.9	46.9	39.8	73.9	53.9	27.0	14.1	*1)
Vert.	10480.0	43.9	-	39.3	-2.4	34.4	-	46.3	-	68.2	-	21.9	-	Floor noise
Vert.	15720.0	45.4	35.5	37.2	-0.7	33.6	-	48.2	38.3	73.9	53.9	25.7	15.6	Floor noise

Result (QP / PK) = Reading + Ant Factor + Loss (Cable+Attenuator+Filter+Distance factor(above 1 GHz)) - Gain(Amplifier)

Result (AV)= Reading + Ant Factor + Loss (Cable+Attenuator+Filter+Distance factor(above 1 GHz)) - Gain(Amplifier) + Duty factor

*Other frequency noises omitted in this report were not seen or had enough margin (more than 20 dB).

*QP detector was used up to 1GHz.

*1) Not Out of Band emission(Leakage Power)

Distance factor:	1 GHz - 10 GHz	20log(3.6 m / 3.0 m) = 1.59 dB
	10 GHz - 40 GHz	20log(1.0 m / 3.0 m) = -9.5 dB

Radiated Spurious Emission

Test place Ise EMC Lab.
Semi Anechoic Chamber No.2
Date September 30, 2022
Temperature / Humidity 22 deg. C / 55 % RH
Engineer Keiya Ido
 (1 GHz - 10 GHz)
Mode Tx 11a 5240 MHz

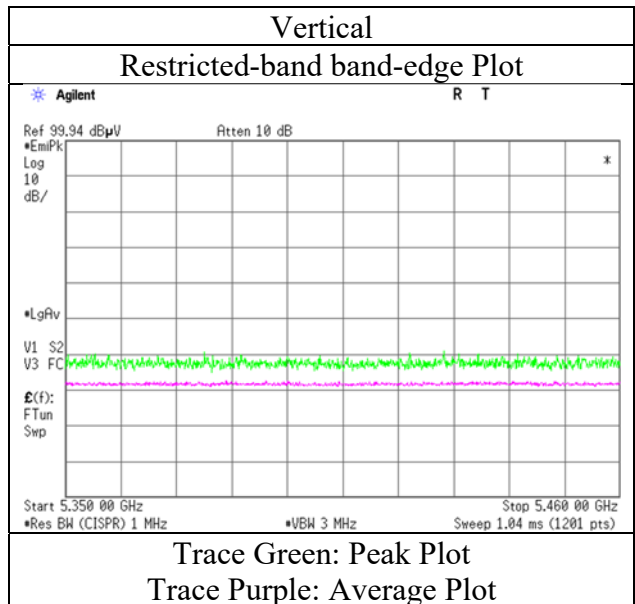
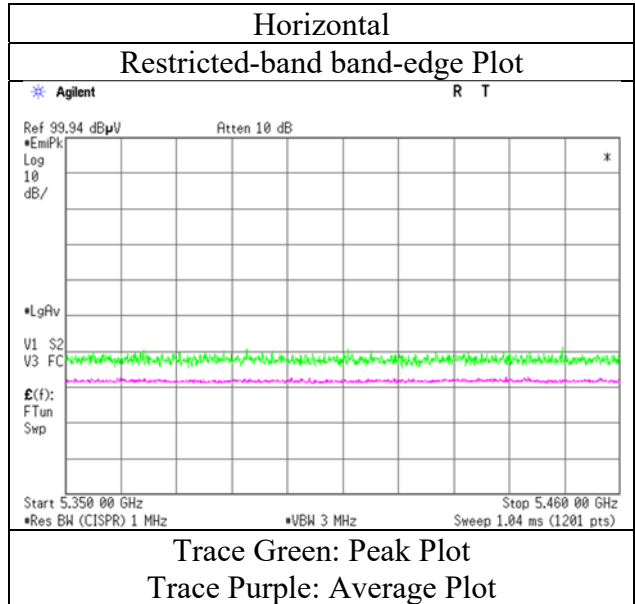

* The measurement was conducted for a sufficiently long enough time to detect any possible spurious emissions.
Final result of restricted band edge was shown in tabular data.

Radiated Spurious Emission

Test place	Ise EMC Lab.	
Semi Anechoic Chamber	No.2	No.2
Date	October 2, 2022	October 5, 2022
Temperature / Humidity	24 deg. C / 52 % RH	24 deg. C / 50 % RH
Engineer	Nachi Konegawa	Hiroyuki Furutaka
	(1 GHz - 10 GHz)	(10 GHz - 40 GHz)
Mode	Tx 11a 5745 MHz	

Polarity	Frequency	Reading (QP / PK)	Reading (AV)	Ant. Factor	Loss	Gain	Duty Factor	Result (QP / PK)	Result (AV)	Limit (QP / PK)	Limit (AV)	Margin (QP / PK)	Margin (AV)	Remark
[Hori/Vert]	[MHz]	[dBuV]	[dBuV]	[dB/m]	[dB]	[dB]	[dB]	[dBuV/m]	[dBuV/m]	[dBuV/m]	[dBuV/m]	[dB]	[dB]	
Hori.	5650.0	43.8	-	31.8	5.6	33.9	-	47.2	-	68.2	-	21.0	-	
Hori.	5700.0	46.5	-	31.9	5.6	33.9	-	50.0	-	105.2	-	55.2	-	
Hori.	5720.0	50.3	-	31.9	5.6	33.9	-	53.8	-	110.8	-	57.0	-	
Hori.	5725.0	55.7	-	31.9	5.6	33.9	-	59.3	-	122.2	-	63.0	-	
Hori.	11490.0	43.5	34.2	39.5	-1.9	33.9	-	47.2	37.9	73.9	53.9	26.7	16.0	Floor noise
Hori.	17235.0	44.7	-	42.3	-0.3	33.0	-	53.7	-	68.2	-	14.5	-	Floor noise
Vert.	5650.0	44.0	-	31.8	5.6	33.9	-	47.5	-	68.2	-	20.8	-	
Vert.	5700.0	44.6	-	31.9	5.6	33.9	-	48.1	-	105.2	-	57.1	-	
Vert.	5720.0	46.3	-	31.9	5.6	33.9	-	49.8	-	110.8	-	61.0	-	
Vert.	5725.0	50.4	-	31.9	5.6	33.9	-	54.0	-	122.2	-	68.2	-	
Vert.	11490.0	43.6	34.3	39.5	-1.9	33.9	-	47.3	38.0	73.9	53.9	26.6	15.9	Floor noise
Vert.	17235.0	44.9	-	42.3	-0.3	33.0	-	53.9	-	68.2	-	14.3	-	Floor noise

Result (QP / PK) = Reading + Ant Factor + Loss (Cable+Attenuator+Filter+Distance factor(above 1 GHz)) - Gain(Amplifier)

Result (AV)= Reading + Ant Factor + Loss (Cable+Attenuator+Filter+Distance factor(above 1 GHz)) - Gain(Amplifier) + Duty factor

*Other frequency noises omitted in this report were not seen or had enough margin (more than 20 dB).

*QP detector was used up to 1GHz.

Distance factor: 1 GHz - 10 GHz 20log(3.6 m / 3.0 m) = 1.59 dB
 10 GHz - 40 GHz 20log(1.0 m / 3.0 m) = -9.5 dB

Radiated Spurious Emission

Test place Ise EMC Lab.
Semi Anechoic Chamber No.2
Date October 2, 2022
Temperature / Humidity 24 deg. C / 52 % RH
Engineer Nachi Konegawa
 (1 GHz - 10 GHz)
Mode Tx 11a 5745 MHz

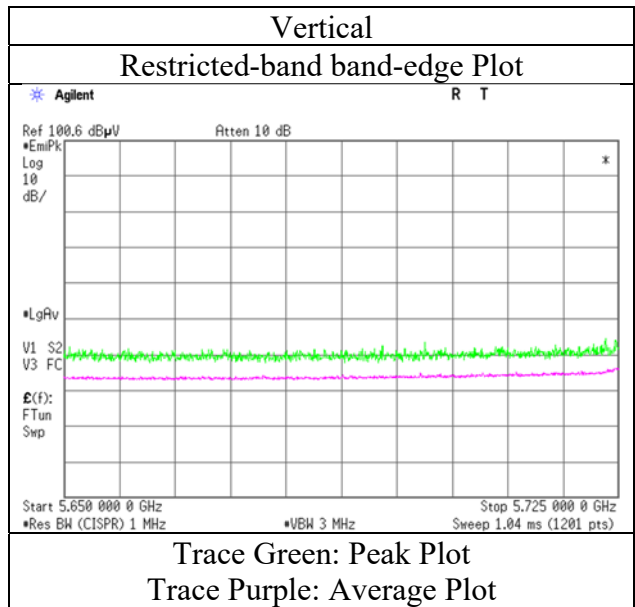
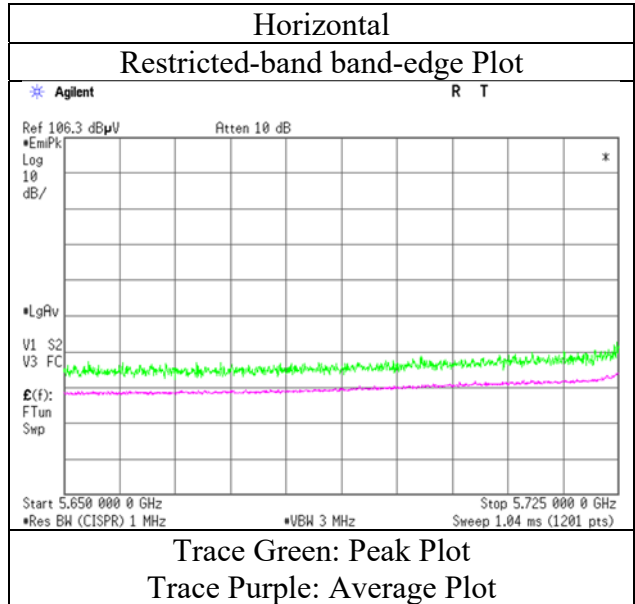

* The measurement was conducted for a sufficiently long enough time to detect any possible spurious emissions.
Final result of restricted band edge was shown in tabular data.

Radiated Spurious Emission

Test place	Ise EMC Lab.	
Semi Anechoic Chamber	No.2	No.2
Date	October 2, 2022	October 5, 2022
Temperature / Humidity	24 deg. C / 52 % RH	24 deg. C / 50 % RH
Engineer	Nachi Konegawa (1 GHz - 10 GHz)	Hiroyuki Furutaka (10 GHz - 40 GHz)
Mode	Tx 11a 5785 MHz	

Polarity	Frequency	Reading (QP / PK)	Reading (AV)	Ant. Factor	Loss	Gain	Duty Factor	Result (QP / PK)	Result (AV)	Limit (QP / PK)	Limit (AV)	Margin (QP / PK)	Margin (AV)	Remark
[Hori/Vert]	[MHz]	[dBuV]	[dBuV]	[dB/m]	[dB]	[dB]	[dB]	[dBuV/m]	[dBuV/m]	[dBuV/m]	[dBuV/m]	[dB]	[dB]	
Hori.	11570.0	42.6	33.6	39.2	-1.8	33.9	-	46.1	37.1	73.9	53.9	27.8	16.8	Floor noise
Hori.	17355.0	45.1	-	43.4	-0.3	33.0	-	55.2	-	68.2	-	13.0	-	Floor noise
Vert.	11570.0	42.8	33.7	39.2	-1.8	33.9	-	46.3	37.2	73.9	53.9	27.6	16.7	Floor noise
Vert.	17355.0	45.3	-	43.4	-0.3	33.0	-	55.4	-	68.2	-	12.8	-	Floor noise

Result (QP / PK) = Reading + Ant Factor + Loss (Cable+Attenuator+Filter+Distance factor(above 1 GHz)) - Gain(Amplifier)

Result (AV)= Reading + Ant Factor + Loss (Cable+Attenuator+Filter+Distance factor(above 1 GHz)) - Gain(Amplifier) + Duty factor

*Other frequency noises omitted in this report were not seen or had enough margin (more than 20 dB).

*QP detector was used up to 1GHz.

Distance factor:	1 GHz - 10 GHz	20log(3.6 m / 3.0 m) = 1.59 dB
	10 GHz - 40 GHz	20log(1.0 m / 3.0 m) = -9.5 dB

Radiated Spurious Emission

Test place	Ise EMC Lab.	
Semi Anechoic Chamber	No.2	No.2
Date	October 2, 2022	October 5, 2022
Temperature / Humidity	24 deg. C / 52 % RH	24 deg. C / 50 % RH
Engineer	Nachi Konegawa	Hiroyuki Furutaka
	(1 GHz - 10 GHz)	(10 GHz - 40 GHz)
Mode	Tx 11a 5805 MHz	

Polarity	Frequency	Reading (QP / PK)	Reading (AV)	Ant. Factor	Loss	Gain	Duty Factor	Result (QP / PK)	Result (AV)	Limit (QP / PK)	Limit (AV)	Margin (QP / PK)	Margin (AV)	Remark
[Hori/Vert]	[MHz]	[dBuV]	[dBuV]	[dB/m]	[dB]	[dB]	[dB]	[dBuV/m]	[dBuV/m]	[dBuV/m]	[dBuV/m]	[dB]	[dB]	
Hori.	5850.0	45.1	-	32.2	5.6	33.9	-	49.0	-	122.2	-	73.2	-	
Hori.	5855.0	44.5	-	32.2	5.6	33.9	-	48.4	-	110.8	-	62.4	-	
Hori.	5875.0	43.5	-	32.2	5.7	33.9	-	47.5	-	105.2	-	57.7	-	
Hori.	5925.0	44.1	-	32.3	5.7	33.9	-	48.1	-	68.2	-	20.1	-	
Hori.	11610.0	42.7	33.7	39.1	-1.8	33.9	-	46.1	37.1	73.9	53.9	27.8	16.8	Floor noise
Hori.	17415.0	44.2	-	43.9	-0.3	32.9	-	54.8	-	68.2	-	13.4	-	Floor noise
Vert.	5850.0	43.3	-	32.2	5.6	33.9	-	47.2	-	122.2	-	75.0	-	
Vert.	5855.0	43.2	-	32.2	5.6	33.9	-	47.1	-	110.8	-	63.7	-	
Vert.	5875.0	42.7	-	32.2	5.7	33.9	-	46.6	-	105.2	-	58.6	-	
Vert.	5925.0	42.8	-	32.3	5.7	33.9	-	46.8	-	68.2	-	21.4	-	
Vert.	11610.0	42.8	33.9	39.1	-1.8	33.9	-	46.2	37.3	73.9	53.9	27.7	16.6	Floor noise
Vert.	17415.0	44.5	-	43.9	-0.3	32.9	-	55.1	-	68.2	-	13.1	-	Floor noise

Result (QP / PK) = Reading + Ant Factor + Loss (Cable+Attenuator+Filter+Distance factor(above 1 GHz)) - Gain(Amplifier)

Result (AV)= Reading + Ant Factor + Loss (Cable+Attenuator+Filter+Distance factor(above 1 GHz)) - Gain(Amplifier) + Duty factor

*Other frequency noises omitted in this report were not seen or had enough margin (more than 20 dB).

*QP detector was used up to 1GHz.

Distance factor: 1 GHz - 10 GHz $20\log(3.6\text{ m} / 3.0\text{ m}) = 1.59\text{ dB}$
 10 GHz - 40 GHz $20\log(1.0\text{ m} / 3.0\text{ m}) = -9.5\text{ dB}$

Radiated Spurious Emission

Test place Ise EMC Lab.
Semi Anechoic Chamber No.2
Date October 2, 2022
Temperature / Humidity 24 deg. C / 52 % RH
Engineer Nachi Konegawa
 (1 GHz - 10 GHz)
Mode Tx 11a 5805 MHz

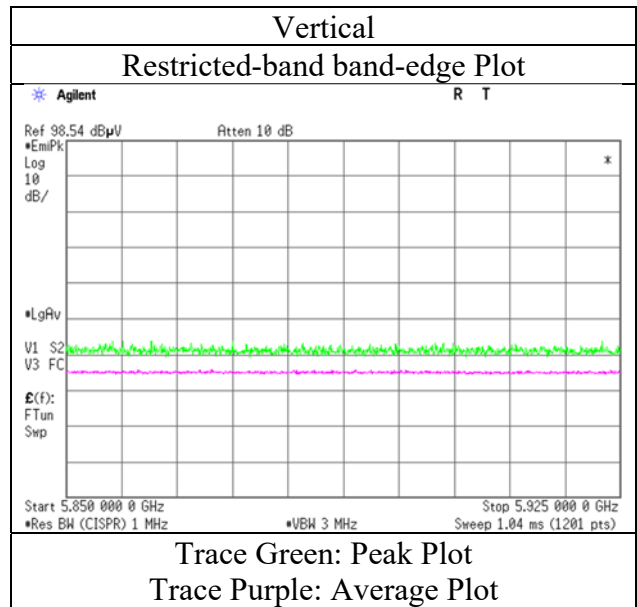
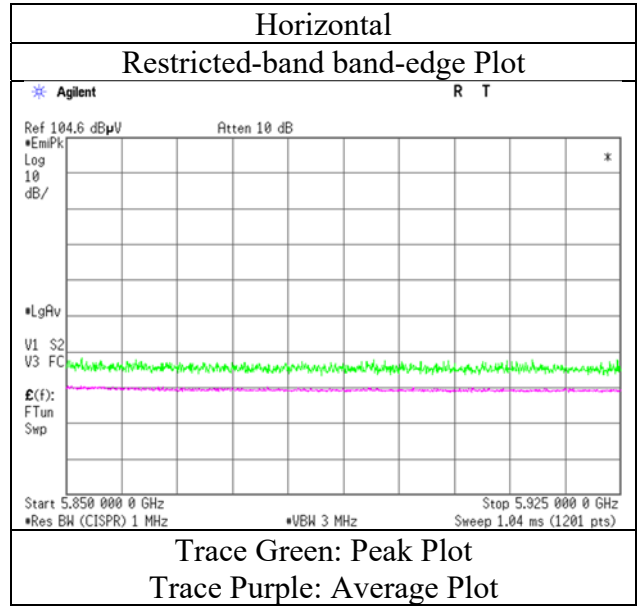

* The measurement was conducted for a sufficiently long enough time to detect any possible spurious emissions.
Final result of restricted band edge was shown in tabular data.

Radiated Spurious Emission

Test place	Ise EMC Lab.		
Semi Anechoic Chamber	No.2	No.2	No.2
Date	September 30, 2022	October 5, 2022	October 6, 2022
Temperature / Humidity	22 deg. C / 55 % RH	24 deg. C / 50 % RH	22 deg. C / 42 % RH
Engineer	Keiya Ido	Hiroyuki Furutaka	Keiya Ido
Mode	(1 GHz - 10 GHz)	(10 GHz -40 GHz)	(Below 1 GHz)
	Tx 11ac-20 5180 MHz		

Polarity [Hori/Vert]	Frequency [MHz]	Reading (QP / PK) [dBuV]	Reading (AV) [dBuV]	Ant. Factor [dB/m]	Loss [dB]	Gain [dB]	Duty Factor [dB]	Result (QP / PK) [dBuV/m]	Result (AV) [dBuV/m]	Limit (QP / PK) [dBuV/m]	Limit (AV) [dBuV/m]	Margin (QP / PK) [dB]	Margin (AV) [dB]	Remark
Hori.	99.8	34.6	-	10.3	7.4	28.4	-	23.8	-	43.5	-	19.7	-	
Hori.	200.0	47.5	-	11.9	8.1	28.0	-	39.5	-	43.5	-	4.0	-	
Hori.	234.5	36.7	-	12.2	8.3	27.8	-	29.3	-	46.0	-	16.7	-	
Hori.	244.0	36.1	-	12.1	8.4	27.8	-	28.8	-	46.0	-	17.2	-	
Hori.	800.0	32.0	-	20.9	10.9	29.1	-	34.7	-	46.0	-	11.3	-	
Hori.	926.2	33.2	-	22.2	11.3	28.8	-	37.9	-	46.0	-	8.1	-	
Hori.	5150.0	49.2	40.4	31.7	5.4	34.1	1.8	52.2	45.3	73.9	53.9	21.7	8.7	*1)
Hori.	10360.0	44.8	-	39.2	-2.5	34.5	-	47.1	-	68.2	-	21.2	-	Floor noise
Hori.	15540.0	45.8	36.4	37.4	-0.8	33.5	-	49.0	39.6	73.9	53.9	24.9	14.3	Floor noise
Vert.	99.8	32.0	-	10.3	7.4	28.4	-	21.2	-	43.5	-	22.3	-	
Vert.	200.0	41.7	-	11.9	8.1	28.0	-	33.7	-	43.5	-	9.8	-	
Vert.	234.5	34.5	-	12.2	8.3	27.8	-	27.1	-	46.0	-	18.9	-	
Vert.	244.0	32.9	-	12.1	8.4	27.8	-	25.6	-	46.0	-	20.4	-	
Vert.	800.0	34.8	-	20.9	10.9	29.1	-	37.5	-	46.0	-	8.5	-	
Vert.	926.2	31.8	-	22.2	11.3	28.8	-	36.5	-	46.0	-	9.5	-	
Vert.	5150.0	44.5	34.4	31.7	5.4	34.1	1.8	47.6	39.3	73.9	53.9	26.3	14.6	*1)
Vert.	10360.0	44.7	-	39.2	-2.5	34.5	-	47.0	-	68.2	-	21.3	-	Floor noise
Vert.	15540.0	45.7	36.3	37.4	-0.8	33.5	-	48.9	39.5	73.9	53.9	25.0	14.4	Floor noise

Result (QP / PK) = Reading + Ant Factor + Loss (Cable+Attenuator+Filter+Distance factor(above 1 GHz)) - Gain(Amplifier)

Result (AV)= Reading + Ant Factor + Loss (Cable+Attenuator+Filter+Distance factor(above 1 GHz)) - Gain(Amplifier) + Duty factor

*Other frequency noises omitted in this report were not seen or had enough margin (more than 20 dB).

*QP detector was used up to 1GHz.

*1) Not Out of Band emission(Leakage Power)

Distance factor: 1 GHz - 10 GHz 20log(3.6 m / 3.0 m) = 1.59 dB
 10 GHz - 40 GHz 20log(1.0 m / 3.0 m) = -9.5 dB

Radiated Spurious Emission

Test place	Ise EMC Lab.
Semi Anechoic Chamber	No.2
Date	September 30, 2022
Temperature / Humidity	22 deg. C / 55 % RH
Engineer	Keiya Ido (1 GHz - 10 GHz)
Mode	Tx 11ac-20 5180 MHz

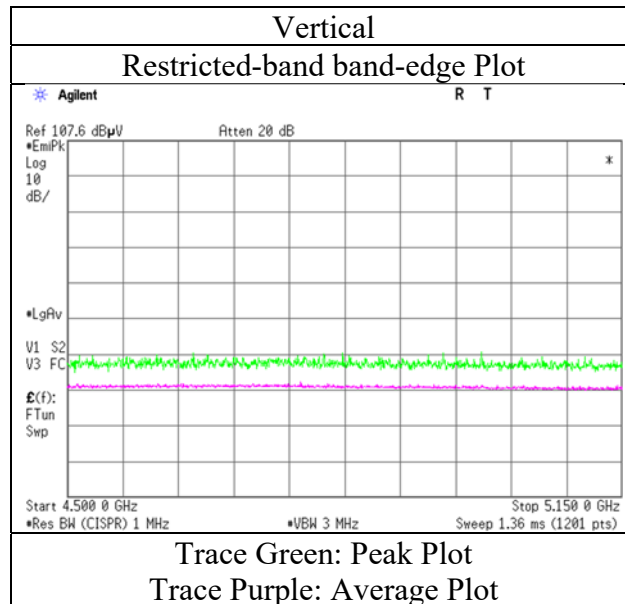
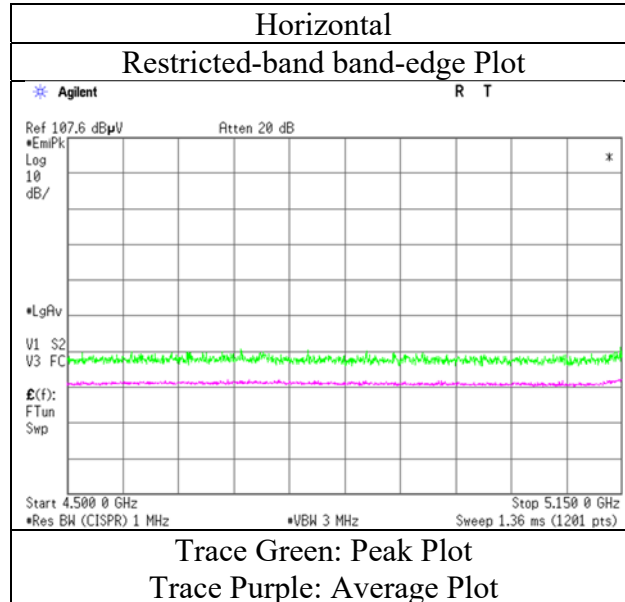

* The measurement was conducted for a sufficiently long enough time to detect any possible spurious emissions.
Final result of restricted band edge was shown in tabular data.

Radiated Spurious Emission

Test place	Ise EMC Lab.	
Semi Anechoic Chamber	No.2	No.2
Date	September 30, 2022	October 5, 2022
Temperature / Humidity	22 deg. C / 55 % RH	24 deg. C / 50 % RH
Engineer	Keiya Ido	Hiroyuki Furutaka
	(1 GHz - 10 GHz)	(10 GHz - 40 GHz)
Mode	Tx 11ac-20 5220 MHz	

Polarity [Hori/Vert]	Frequency [MHz]	Reading (QP / PK) [dBuV]	Reading (AV) [dBuV]	Ant. Factor [dB/m]	Loss [dB]	Gain [dB]	Duty Factor [dB]	Result (QP / PK) [dBuV/m]	Result (AV) [dBuV/m]	Limit (QP / PK) [dBuV/m]	Limit (AV) [dBuV/m]	Margin (QP / PK) [dB]	Margin (AV) [dB]	Remark
Hori.	10440.0	44.4	-	39.3	-2.4	34.4	-	46.8	-	68.2	-	21.4	-	Floor noise
Hori.	15660.0	45.9	36.9	37.3	-0.7	33.6	-	48.9	39.9	73.9	53.9	25.1	14.1	Floor noise
Vert.	10440.0	43.9	-	39.3	-2.4	34.4	-	46.3	-	68.2	-	21.9	-	Floor noise
Vert.	15660.0	45.4	35.4	37.3	-0.7	33.6	-	48.4	38.4	73.9	53.9	25.6	15.6	Floor noise

Result (QP / PK) = Reading + Ant Factor + Loss (Cable+Attenuator+Filter+Distance factor(above 1 GHz)) - Gain(Amplifier)

Result (AV)= Reading + Ant Factor + Loss (Cable+Attenuator+Filter+Distance factor(above 1 GHz)) - Gain(Amplifier) + Duty factor

*Other frequency noises omitted in this report were not seen or had enough margin (more than 20 dB).

*QP detector was used up to 1GHz.

Distance factor:	1 GHz - 10 GHz	$20\log(3.6\text{ m} / 3.0\text{ m}) = 1.59\text{ dB}$
	10 GHz - 40 GHz	$20\log(1.0\text{ m} / 3.0\text{ m}) = -9.5\text{ dB}$

Radiated Spurious Emission

Test place	Ise EMC Lab.	
Semi Anechoic Chamber	No.2	No.2
Date	September 30, 2022	October 5, 2022
Temperature / Humidity	22 deg. C / 55 % RH	24 deg. C / 50 % RH
Engineer	Keiya Ido	Hiroyuki Furutaka
	(1 GHz - 10 GHz)	(10 GHz - 40 GHz)
Mode	Tx 11ac-20 5240 MHz	

Polarity	Frequency	Reading (QP / PK)	Reading (AV)	Ant. Factor	Loss	Gain	Duty Factor	Result (QP / PK)	Result (AV)	Limit (QP / PK)	Limit (AV)	Margin (QP / PK)	Margin (AV)	Remark
[Hori/Vert]	[MHz]	[dBuV]	[dBuV]	[dB/m]	[dB]	[dB]	[dB]	[dBuV/m]	[dBuV/m]	[dBuV/m]	[dBuV/m]	[dB]	[dB]	
Hori.	5350.0	43.9	33.9	31.6	5.5	34.0	1.8	46.9	38.7	73.9	53.9	27.0	15.2	*1)
Hori.	10480.0	44.2	-	39.3	-2.4	34.4	-	46.6	-	68.2	-	21.6	-	Floor noise
Hori.	15720.0	45.4	36.7	37.2	-0.7	33.6	-	48.2	39.5	73.9	53.9	25.7	14.4	Floor noise
Vert.	5350.0	47.6	34.0	31.6	5.5	34.0	1.8	50.7	38.8	73.9	53.9	23.2	15.1	*1)
Vert.	10480.0	44.0	-	39.3	-2.4	34.4	-	46.4	-	68.2	-	21.8	-	Floor noise
Vert.	15720.0	45.2	35.3	37.2	-0.7	33.6	-	48.0	38.1	73.9	53.9	25.9	15.8	Floor noise

Result (QP / PK) = Reading + Ant Factor + Loss (Cable+Attenuator+Filter+Distance factor(above 1 GHz)) - Gain(Amplifier)

Result (AV)= Reading + Ant Factor + Loss (Cable+Attenuator+Filter+Distance factor(above 1 GHz)) - Gain(Amplifier) + Duty factor

*Other frequency noises omitted in this report were not seen or had enough margin (more than 20 dB).

*QP detector was used up to 1GHz.

*1) Not Out of Band emission(Leakage Power)

Distance factor: 1 GHz - 10 GHz $20\log(3.6 \text{ m} / 3.0 \text{ m}) = 1.59 \text{ dB}$
 10 GHz - 40 GHz $20\log(1.0 \text{ m} / 3.0 \text{ m}) = -9.5 \text{ dB}$

Radiated Spurious Emission

Test place Ise EMC Lab.
Semi Anechoic Chamber No.2
Date September 30, 2022
Temperature / Humidity 22 deg. C / 55 % RH
Engineer Keiya Ido
 (1 GHz - 10 GHz)
Mode Tx 11ac-20 5240 MHz

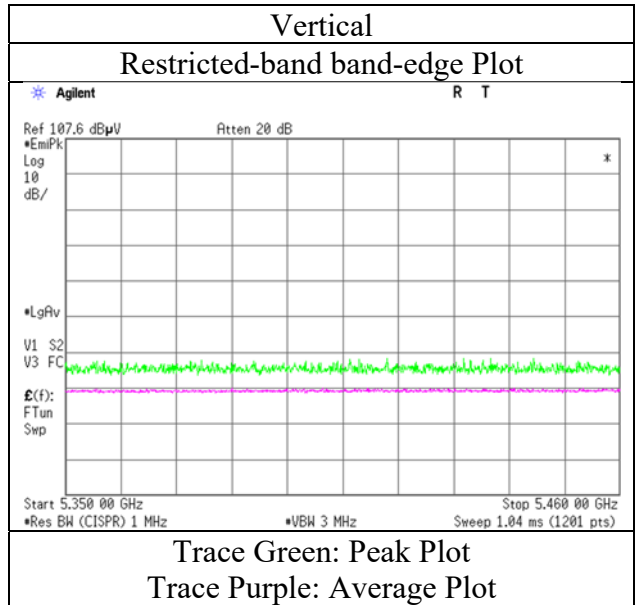
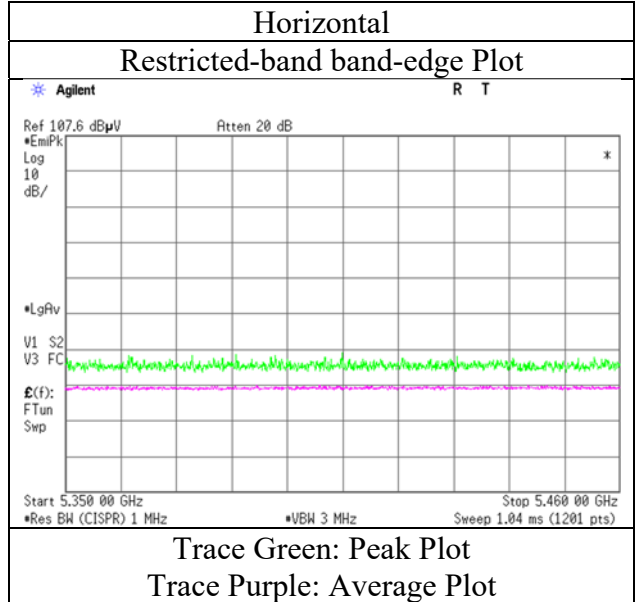

* The measurement was conducted for a sufficiently long enough time to detect any possible spurious emissions.
Final result of restricted band edge was shown in tabular data.

Radiated Spurious Emission

Test place	Ise EMC Lab.	
Semi Anechoic Chamber	No.2	No.2
Date	October 2, 2022	October 5, 2022
Temperature / Humidity	24 deg. C / 52 % RH	24 deg. C / 50 % RH
Engineer	Nachi Konegawa	Hiroyuki Furutaka
	(1 GHz - 10 GHz)	(10 GHz - 40 GHz)
Mode	Tx 11ac-20 5745 MHz	

Polarity [Hori/Vert]	Frequency [MHz]	Reading (QP / PK) [dBuV]	Reading (AV) [dBuV]	Ant. Factor [dB/m]	Loss [dB]	Gain [dB]	Duty Factor [dB]	Result (QP / PK) [dBuV/m]	Result (AV) [dBuV/m]	Limit (QP / PK) [dBuV/m]	Limit (AV) [dBuV/m]	Margin (QP / PK) [dB]	Margin (AV) [dB]	Remark
Hori.	5650.0	45.4	-	31.8	5.6	33.9	-	48.9	-	68.2	-	19.4	-	
Hori.	5700.0	46.0	-	31.9	5.6	33.9	-	49.6	-	105.2	-	55.7	-	
Hori.	5720.0	48.8	-	31.9	5.6	33.9	-	52.4	-	110.8	-	58.5	-	
Hori.	5725.0	54.4	-	31.9	5.6	33.9	-	58.0	-	122.2	-	64.2	-	
Hori.	11490.0	43.6	34.3	39.5	-1.9	33.9	-	47.3	38.0	73.9	53.9	26.6	15.9	Floor noise
Hori.	17235.0	44.7	-	42.3	-0.3	33.0	-	53.7	-	68.2	-	14.5	-	Floor noise
Vert.	5650.0	43.3	-	31.8	5.6	33.9	-	46.7	-	68.2	-	21.5	-	
Vert.	5700.0	44.3	-	31.9	5.6	33.9	-	47.8	-	105.2	-	57.4	-	
Vert.	5720.0	45.8	-	31.9	5.6	33.9	-	49.4	-	110.8	-	61.4	-	
Vert.	5725.0	49.0	-	31.9	5.6	33.9	-	52.6	-	122.2	-	69.6	-	
Vert.	11490.0	43.0	34.3	39.5	-1.9	33.9	-	46.7	38.0	73.9	53.9	27.2	15.9	Floor noise
Vert.	17235.0	45.0	-	42.3	-0.3	33.0	-	54.0	-	68.2	-	14.2	-	Floor noise

Result (QP / PK) = Reading + Ant Factor + Loss (Cable+Attenuator+Filter+Distance factor(above 1 GHz)) - Gain(Amplifier)

Result (AV) = Reading + Ant Factor + Loss (Cable+Attenuator+Filter+Distance factor(above 1 GHz)) - Gain(Amplifier) + Duty factor

*Other frequency noises omitted in this report were not seen or had enough margin (more than 20 dB).

*QP detector was used up to 1GHz.

Radiated Spurious Emission

Test place Ise EMC Lab.
Semi Anechoic Chamber No.2
Date October 2, 2022
Temperature / Humidity 24 deg. C / 52 % RH
Engineer Nachi Konegawa
 (1 GHz - 10 GHz)
Mode Tx 11ac-20 5745 MHz

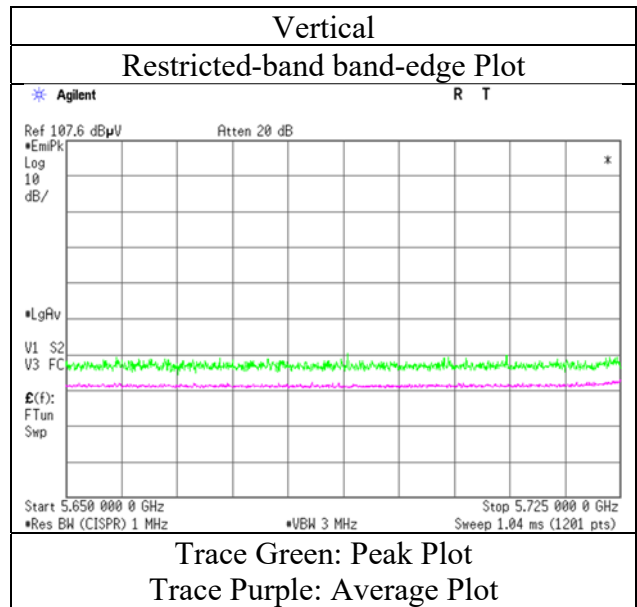
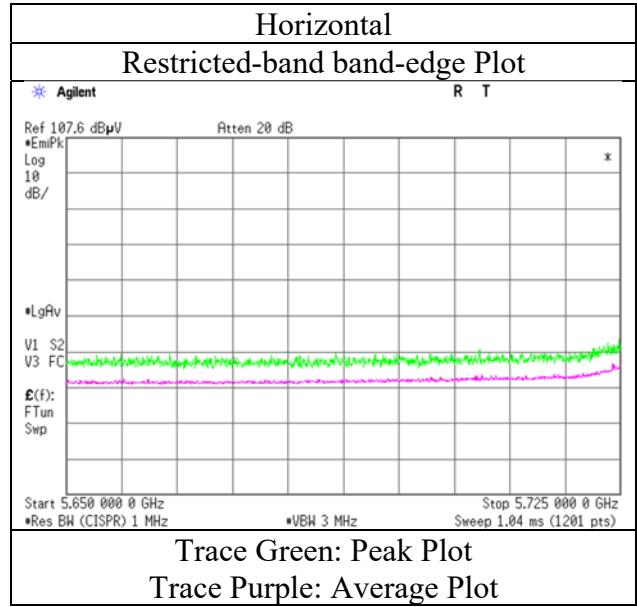

* The measurement was conducted for a sufficiently long enough time to detect any possible spurious emissions.
Final result of restricted band edge was shown in tabular data.

Radiated Spurious Emission

Test place	Ise EMC Lab.	
Semi Anechoic Chamber	No.2	No.2
Date	October 2, 2022	October 5, 2022
Temperature / Humidity	24 deg. C / 52 % RH	24 deg. C / 50 % RH
Engineer	Nachi Konegawa	Hiroyuki Furutaka
	(1 GHz - 10 GHz)	(10 GHz - 40 GHz)
Mode	Tx 11ac-20 5785 MHz	

Polarity [Hori/Vert]	Frequency [MHz]	Reading (QP / PK) [dBuV]	Reading (AV) [dBuV]	Ant. Factor [dB/m]	Loss [dB]	Gain [dB]	Duty Factor [dB]	Result (QP / PK) [dBuV/m]	Result (AV) [dBuV/m]	Limit (QP / PK) [dBuV/m]	Limit (AV) [dBuV/m]	Margin (QP / PK) [dB]	Margin (AV) [dB]	Remark
Hori.	11570.0	42.7	33.8	39.2	-1.8	33.9	-	46.2	37.3	73.9	53.9	27.7	16.6	Floor noise
Hori.	17355.0	45.1	-	43.4	-0.3	33.0	-	55.2	-	68.2	-	13.0	-	Floor noise
Vert.	11570.0	42.9	33.7	39.2	-1.8	33.9	-	46.4	37.2	73.9	53.9	27.5	16.7	Floor noise
Vert.	17355.0	45.1	-	43.4	-0.3	33.0	-	55.2	-	68.2	-	13.0	-	Floor noise

Result (QP / PK) = Reading + Ant Factor + Loss (Cable+Attenuator+Filter+Distance factor(above 1 GHz)) - Gain(Amplifier)

Result (AV)= Reading + Ant Factor + Loss (Cable+Attenuator+Filter+Distance factor(above 1 GHz)) - Gain(Amplifier) + Duty factor

*Other frequency noises omitted in this report were not seen or had enough margin (more than 20 dB).

*QP detector was used up to 1GHz.

Distance factor:	1 GHz - 10 GHz	$20\log(3.6\text{ m} / 3.0\text{ m}) = 1.59\text{ dB}$
	10 GHz - 40 GHz	$20\log(1.0\text{ m} / 3.0\text{ m}) = -9.5\text{ dB}$

Radiated Spurious Emission

Test place	Ise EMC Lab.	
Semi Anechoic Chamber	No.2	No.2
Date	October 2, 2022	October 5, 2022
Temperature / Humidity	24 deg. C / 52 % RH	24 deg. C / 50 % RH
Engineer	Nachi Konegawa	Hiroyuki Furutaka
	(1 GHz - 10 GHz)	(10 GHz - 40 GHz)
Mode	Tx 11ac-20 5805 MHz	

Polarity	Frequency	Reading (QP / PK)	Reading (AV)	Ant. Factor	Loss	Gain	Duty Factor	Result (QP / PK)	Result (AV)	Limit (QP / PK)	Limit (AV)	Margin (QP / PK)	Margin (AV)	Remark
[Hori/Vert]	[MHz]	[dBuV]	[dBuV]	[dB/m]	[dB]	[dB]	[dB]	[dBuV/m]	[dBuV/m]	[dBuV/m]	[dBuV/m]	[dB]	[dB]	
Hori.	5850.0	44.0	-	32.2	5.6	33.9	-	47.9	-	122.2	-	74.3	-	
Hori.	5855.0	44.6	-	32.2	5.6	33.9	-	48.5	-	110.8	-	62.3	-	
Hori.	5875.0	43.4	-	32.2	5.7	33.9	-	47.4	-	105.2	-	57.8	-	
Hori.	5925.0	43.8	-	32.3	5.7	33.9	-	47.8	-	68.2	-	20.4	-	
Hori.	11610.0	42.8	33.8	39.1	-1.8	33.9	-	46.2	37.2	73.9	53.9	27.7	16.7	Floor noise
Hori.	17415.0	44.4	-	43.9	-0.3	32.9	-	55.0	-	68.2	-	13.2	-	Floor noise
Vert.	5850.0	43.5	-	32.2	5.6	33.9	-	47.4	-	122.2	-	74.8	-	
Vert.	5855.0	43.1	-	32.2	5.6	33.9	-	47.0	-	110.8	-	63.8	-	
Vert.	5875.0	43.6	-	32.2	5.7	33.9	-	47.5	-	105.2	-	57.7	-	
Vert.	5925.0	42.8	-	32.3	5.7	33.9	-	46.9	-	68.2	-	21.3	-	
Vert.	11610.0	42.7	33.8	39.1	-1.8	33.9	-	46.1	37.2	73.9	53.9	27.8	16.7	Floor noise
Vert.	17415.0	44.6	-	43.9	-0.3	32.9	-	55.2	-	68.2	-	13.0	-	Floor noise

Result (QP / PK) = Reading + Ant Factor + Loss (Cable+Attenuator+Filter+Distance factor(above 1 GHz)) - Gain(Amplifier)

Result (AV)= Reading + Ant Factor + Loss (Cable+Attenuator+Filter+Distance factor(above 1 GHz)) - Gain(Amplifier) + Duty factor

*Other frequency noises omitted in this report were not seen or had enough margin (more than 20 dB).

*QP detector was used up to 1GHz.

Distance factor: 1 GHz - 10 GHz 20log(3.6 m / 3.0 m) = 1.59 dB
 10 GHz - 40 GHz 20log(1.0 m / 3.0 m) = -9.5 dB

Radiated Spurious Emission

Test place Ise EMC Lab.
Semi Anechoic Chamber No.2
Date October 2, 2022
Temperature / Humidity 24 deg. C / 52 % RH
Engineer Nachi Konegawa
 (1 GHz - 10 GHz)
Mode Tx 11ac-20 5805 MHz

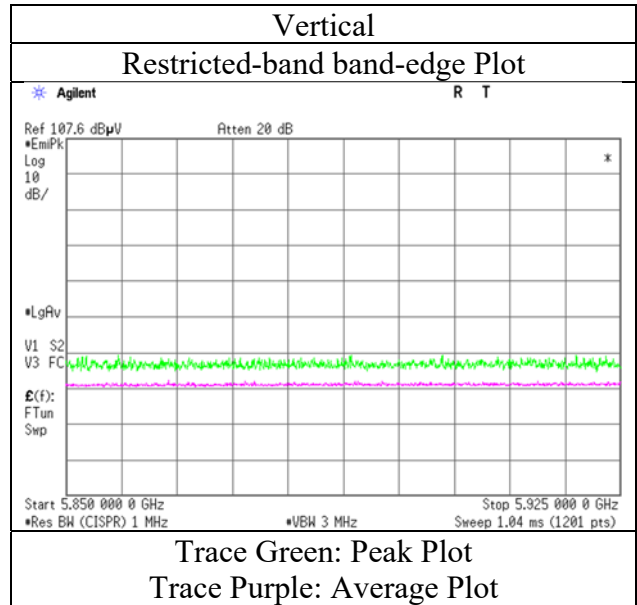
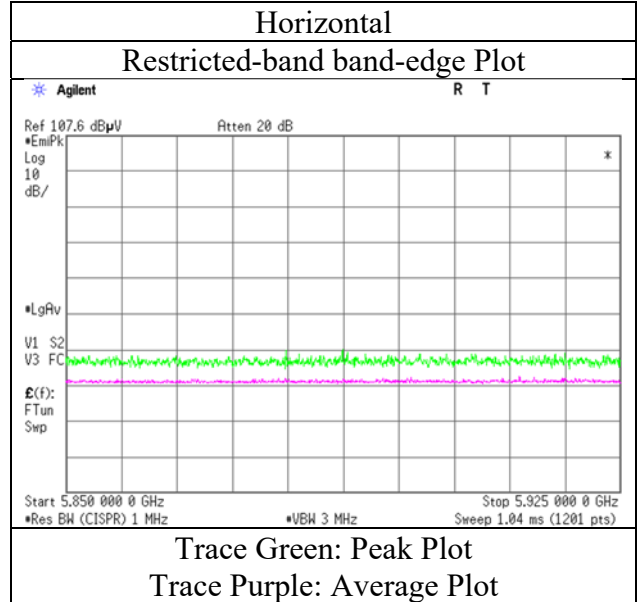

* The measurement was conducted for a sufficiently long enough time to detect any possible spurious emissions.
Final result of restricted band edge was shown in tabular data.

Radiated Spurious Emission

Test place	Ise EMC Lab.	
Semi Anechoic Chamber	No.2	No.2
Date	September 30, 2022	October 5, 2022
Temperature / Humidity	22 deg. C / 55 % RH	26 deg. C / 43 % RH
Engineer	Keiya Ido	Keiya Ido
	(1 GHz - 10 GHz)	(10 GHz - 40 GHz)
Mode	Tx 11ac-40 5190 MHz	

Polarity [Hori/Vert]	Frequency [MHz]	Reading (QP / PK) [dBuV]	Reading (AV) [dBuV]	Ant. Factor [dB/m]	Loss [dB]	Gain [dB]	Duty Factor [dB]	Result (QP / PK) [dBuV/m]	Result (AV) [dBuV/m]	Limit (QP / PK) [dBuV/m]	Limit (AV) [dBuV/m]	Margin (QP / PK) [dB]	Margin (AV) [dB]	Remark
Hori.	5150.0	49.1	36.0	31.7	5.4	34.1	2.6	52.2	41.7	73.9	53.9	21.7	12.2	*1)
Hori.	10380.0	44.7	-	39.2	-2.5	34.5	-	47.0	-	68.2	-	21.2	-	Floor noise
Hori.	15570.0	45.2	36.7	37.3	-0.8	33.5	-	48.2	39.7	73.9	53.9	25.7	14.2	Floor noise
Vert.	5150.0	42.4	34.2	31.7	5.4	34.1	2.6	45.5	39.9	73.9	53.9	28.4	14.0	*1)
Vert.	10380.0	44.7	-	39.2	-2.5	34.5	-	47.0	-	68.2	-	21.2	-	Floor noise
Vert.	15570.0	45.2	36.7	37.3	-0.8	33.5	-	48.2	39.7	73.9	53.9	25.7	14.2	Floor noise

Result (QP / PK) = Reading + Ant Factor + Loss (Cable+Attenuator+Filter+Distance factor(above 1 GHz)) - Gain(Amplifier)

Result (AV)= Reading + Ant Factor + Loss (Cable+Attenuator+Filter+Distance factor(above 1 GHz)) - Gain(Amplifier) + Duty factor

*Other frequency noises omitted in this report were not seen or had enough margin (more than 20 dB).

*QP detector was used up to 1GHz.

*1) Not Out of Band emission(Leakage Power)

Distance factor: 1 GHz - 10 GHz $20\log(3.6\text{ m} / 3.0\text{ m}) = 1.59\text{ dB}$
 10 GHz - 40 GHz $20\log(1.0\text{ m} / 3.0\text{ m}) = -9.5\text{ dB}$

Radiated Spurious Emission

Test place Ise EMC Lab.
Semi Anechoic Chamber No.2
Date September 30, 2022
Temperature / Humidity 22 deg. C / 55 % RH
Engineer Keiya Ido
 (1 GHz - 10 GHz)
Mode Tx 11ac-40 5190 MHz

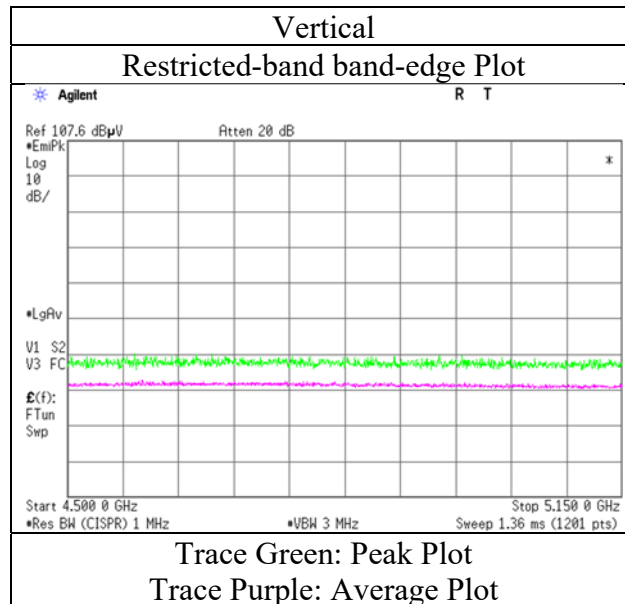
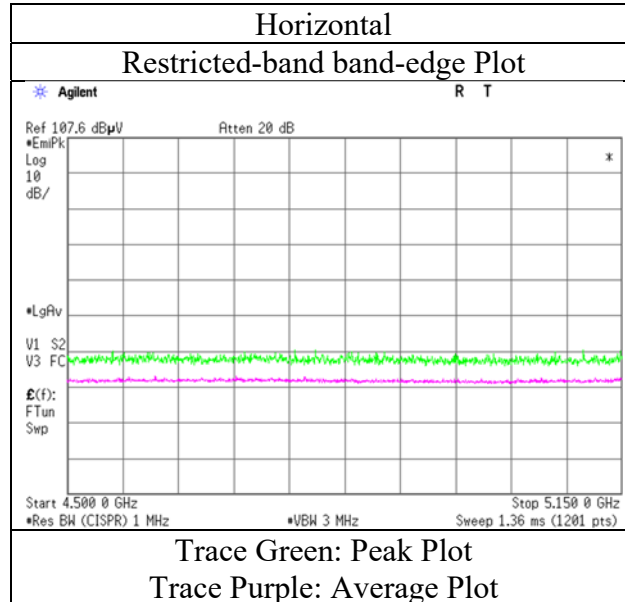

* The measurement was conducted for a sufficiently long enough time to detect any possible spurious emissions.
Final result of restricted band edge was shown in tabular data.

Radiated Spurious Emission

Test place	Ise EMC Lab.	
Semi Anechoic Chamber	No.2	No.2
Date	September 30, 2022	October 5, 2022
Temperature / Humidity	22 deg. C / 55 % RH	26 deg. C / 43 % RH
Engineer	Keiya Ido	Keiya Ido
	(1 GHz - 10 GHz)	(10 GHz - 40 GHz)
Mode	Tx 11ac-40 5230 MHz	

Polarity [Hori/Vert]	Frequency [MHz]	Reading (QP / PK) [dBuV]	Reading (AV) [dBuV]	Ant. Factor [dB/m]	Loss [dB]	Gain [dB]	Duty Factor [dB]	Result (QP / PK) [dBuV/m]	Result (AV) [dBuV/m]	Limit (QP / PK) [dBuV/m]	Limit (AV) [dBuV/m]	Margin (QP / PK) [dB]	Margin (AV) [dB]	Remark
Hori.	5350.0	44.5	35.9	31.6	5.5	34.0	2.6	47.6	41.6	73.9	53.9	26.3	12.3	*1)
Hori.	10460.0	44.6	-	39.3	-2.4	34.4	-	47.0	-	68.2	-	21.2	-	Floor noise
Hori.	15690.0	45.4	36.6	37.1	-0.7	33.6	-	48.1	39.3	73.9	53.9	25.8	14.6	Floor noise
Vert.	5350.0	43.5	34.7	31.6	5.5	34.0	2.6	46.6	40.4	73.9	53.9	27.3	13.5	*1)
Vert.	10460.0	44.3	-	39.3	-2.4	34.4	-	46.7	-	68.2	-	21.5	-	Floor noise
Vert.	15690.0	45.6	36.6	37.1	-0.7	33.6	-	48.4	39.4	73.9	53.9	25.5	14.5	Floor noise

Result (QP / PK) = Reading + Ant Factor + Loss (Cable+Attenuator+Filter+Distance factor(above 1 GHz)) - Gain(Amplifier)

Result (AV)= Reading + Ant Factor + Loss (Cable+Attenuator+Filter+Distance factor(above 1 GHz)) - Gain(Amplifier) + Duty factor

*Other frequency noises omitted in this report were not seen or had enough margin (more than 20 dB).

*QP detector was used up to 1GHz.

*1) Not Out of Band emission(Leakage Power)

Distance factor: 1 GHz - 10 GHz $20\log(3.6\text{ m} / 3.0\text{ m}) = 1.59\text{ dB}$
 10 GHz - 40 GHz $20\log(1.0\text{ m} / 3.0\text{ m}) = -9.5\text{ dB}$

Radiated Spurious Emission

Test place Ise EMC Lab.
 Semi Anechoic Chamber No.2
 Date September 30, 2022
 Temperature / Humidity 22 deg. C / 55 % RH
 Engineer Keiya Ido
 (1 GHz - 10 GHz)
 Mode Tx 11ac-40 5230 MHz

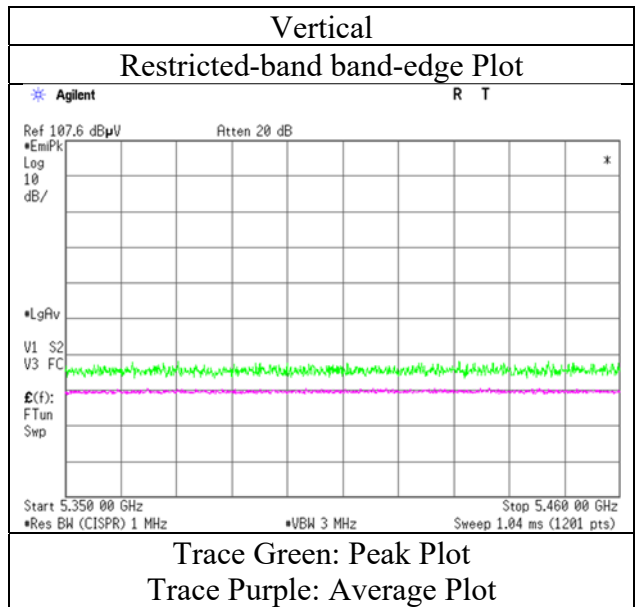
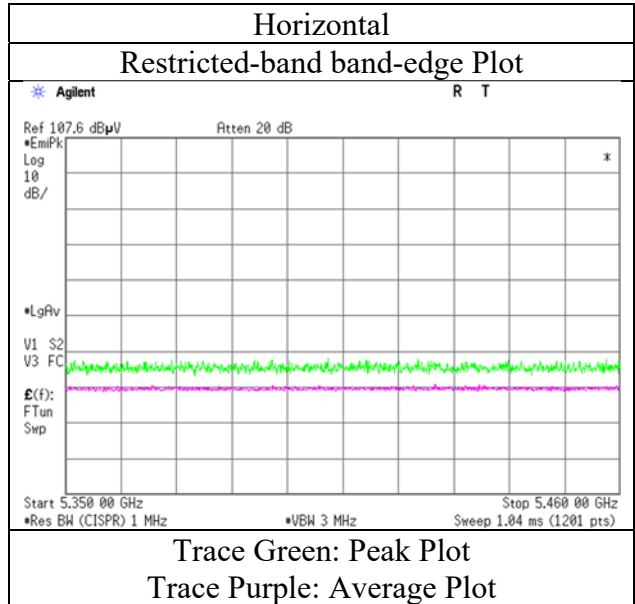

* The measurement was conducted for a sufficiently long enough time to detect any possible spurious emissions.
 Final result of restricted band edge was shown in tabular data.

Radiated Spurious Emission

Test place	Ise EMC Lab.	
Semi Anechoic Chamber	No.2	No.2
Date	October 2, 2022	October 5, 2022
Temperature / Humidity	24 deg. C / 52 % RH	26 deg. C / 43 % RH
Engineer	Nachi Konegawa	Keiya Ido
	(1 GHz - 10 GHz)	(10 GHz - 40 GHz)
Mode	Tx 11ac-40 5755 MHz	

Polarity [Hori/Vert]	Frequency [MHz]	Reading (QP / PK) [dBuV]	Reading (AV) [dBuV]	Ant. Factor [dB/m]	Loss [dB]	Gain [dB]	Duty Factor [dB]	Result (QP / PK) [dBuV/m]	Result (AV) [dBuV/m]	Limit (QP / PK) [dBuV/m]	Limit (AV) [dBuV/m]	Margin (QP / PK) [dB]	Margin (AV) [dB]	Remark
Hori.	5650.0	46.0	-	31.8	5.6	33.9	-	49.4	-	68.2	-	18.8	-	
Hori.	5700.0	46.4	-	31.9	5.6	33.9	-	49.9	-	105.2	-	55.3	-	
Hori.	5720.0	51.5	-	31.9	5.6	33.9	-	55.1	-	110.8	-	55.8	-	
Hori.	5725.0	52.8	-	31.9	5.6	33.9	-	56.4	-	122.2	-	65.9	-	
Hori.	11510.0	42.8	34.2	39.4	-1.8	33.9	-	46.5	37.9	73.9	53.9	27.4	16.0	Floor noise
Hori.	17265.0	45.0	-	42.5	-0.3	33.0	-	54.3	-	68.2	-	14.0	-	Floor noise
Vert.	5650.0	43.9	-	31.8	5.6	33.9	-	47.3	-	68.2	-	20.9	-	
Vert.	5700.0	43.7	-	31.9	5.6	33.9	-	47.2	-	105.2	-	58.0	-	
Vert.	5720.0	47.8	-	31.9	5.6	33.9	-	51.4	-	110.8	-	59.4	-	
Vert.	5725.0	48.0	-	31.9	5.6	33.9	-	51.6	-	122.2	-	70.6	-	
Vert.	11510.0	42.9	34.4	39.4	-1.8	33.9	-	46.6	38.1	73.9	53.9	27.3	15.8	Floor noise
Vert.	17265.0	45.1	-	42.5	-0.3	33.0	-	54.3	-	68.2	-	13.9	-	Floor noise

Result (QP / PK) = Reading + Ant Factor + Loss (Cable+Attenuator+Filter+Distance factor(above 1 GHz)) - Gain(Amplifier)

Result (AV) = Reading + Ant Factor + Loss (Cable+Attenuator+Filter+Distance factor(above 1 GHz)) - Gain(Amplifier) + Duty factor

*Other frequency noises omitted in this report were not seen or had enough margin (more than 20 dB).

*QP detector was used up to 1GHz.

Distance factor: 1 GHz - 10 GHz $20\log(3.6\text{ m} / 3.0\text{ m}) = 1.59\text{ dB}$
 10 GHz - 40 GHz $20\log(1.0\text{ m} / 3.0\text{ m}) = -9.5\text{ dB}$

Radiated Spurious Emission

Test place Ise EMC Lab.
Semi Anechoic Chamber No.2
Date October 2, 2022
Temperature / Humidity 24 deg. C / 52 % RH
Engineer Nachi Konegawa
 (1 GHz - 10 GHz)
Mode Tx 11ac-40 5755 MHz

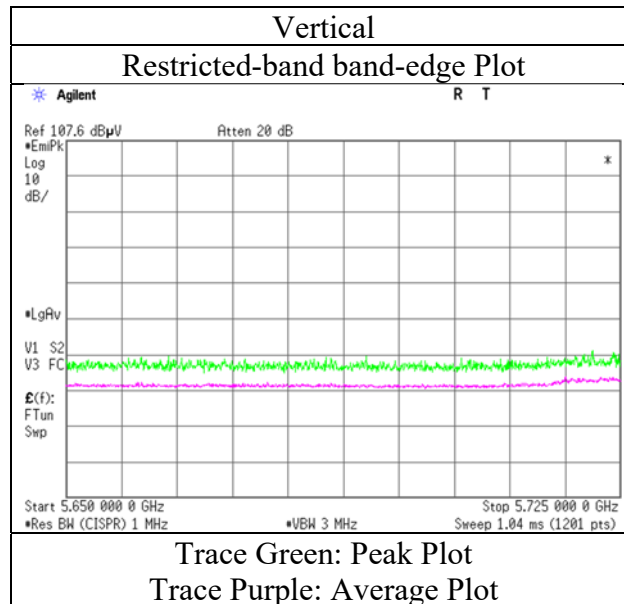
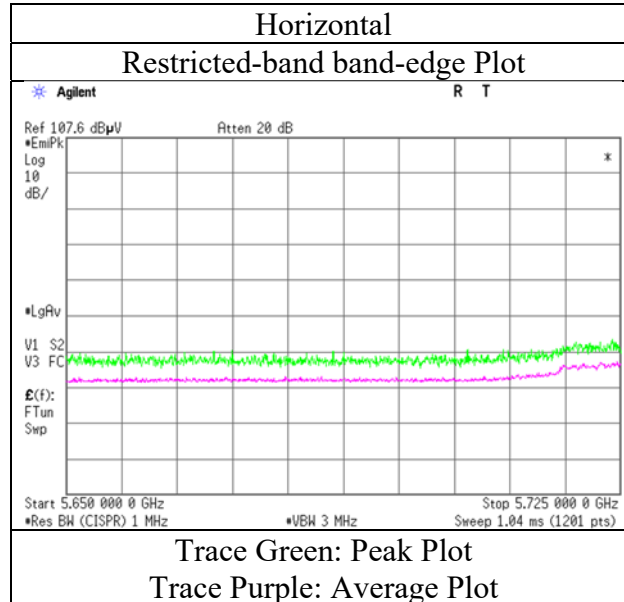

* The measurement was conducted for a sufficiently long enough time to detect any possible spurious emissions.
Final result of restricted band edge was shown in tabular data.

Radiated Spurious Emission

Test place	Ise EMC Lab.	
Semi Anechoic Chamber	No.2	No.2
Date	October 2, 2022	October 5, 2022
Temperature / Humidity	24 deg. C / 52 % RH	26 deg. C / 43 % RH
Engineer	Nachi Konegawa	Keiya Ido
	(1 GHz - 10 GHz)	(10 GHz - 40 GHz)
Mode	Tx 11ac-40 5795 MHz	

Polarity [Hori/Vert]	Frequency [MHz]	Reading (QP / PK) [dBuV]	Reading (AV) [dBuV]	Ant. Factor [dB/m]	Loss [dB]	Gain [dB]	Duty Factor [dB]	Result (QP / PK) [dBuV/m]	Result (AV) [dBuV/m]	Limit (QP / PK) [dBuV/m]	Limit (AV) [dBuV/m]	Margin (QP / PK) [dB]	Margin (AV) [dB]	Remark
Hori.	5850.0	43.9	-	32.2	5.6	33.9	-	47.8	-	122.2	-	74.4	-	
Hori.	5855.0	44.1	-	32.2	5.6	33.9	-	48.0	-	110.8	-	62.8	-	
Hori.	5875.0	43.5	-	32.2	5.7	33.9	-	47.4	-	105.2	-	57.8	-	
Hori.	5925.0	43.7	-	32.3	5.7	33.9	-	47.7	-	68.2	-	20.5	-	
Hori.	11590.0	42.9	34.2	39.1	-1.8	33.9	-	46.3	37.7	73.9	53.9	27.6	16.3	Floor noise
Hori.	17385.0	44.8	-	43.6	-0.3	32.9	-	55.2	-	68.2	-	13.0	-	Floor noise
Vert.	5850.0	43.5	-	32.2	5.6	33.9	-	47.4	-	122.2	-	74.8	-	
Vert.	5855.0	43.5	-	32.2	5.6	33.9	-	47.4	-	110.8	-	63.4	-	
Vert.	5875.0	42.9	-	32.2	5.7	33.9	-	46.8	-	105.2	-	58.4	-	
Vert.	5925.0	42.8	-	32.3	5.7	33.9	-	46.8	-	68.2	-	21.4	-	
Vert.	11590.0	43.0	34.2	39.1	-1.8	33.9	-	46.4	37.7	73.9	53.9	27.5	16.2	Floor noise
Vert.	17385.0	44.9	-	43.6	-0.3	32.9	-	55.3	-	68.2	-	12.9	-	Floor noise

Result (QP / PK) = Reading + Ant Factor + Loss (Cable+Attenuator+Filter+Distance factor(above 1 GHz)) - Gain(Amplifier)

Result (AV) = Reading + Ant Factor + Loss (Cable+Attenuator+Filter+Distance factor(above 1 GHz)) - Gain(Amplifier) + Duty factor

*Other frequency noises omitted in this report were not seen or had enough margin (more than 20 dB).

*QP detector was used up to 1GHz.

Distance factor: 1 GHz - 10 GHz $20\log(3.6\text{ m} / 3.0\text{ m}) = 1.59\text{ dB}$
 10 GHz - 40 GHz $20\log(1.0\text{ m} / 3.0\text{ m}) = -9.5\text{ dB}$

Radiated Spurious Emission

Test place	Ise EMC Lab.
Semi Anechoic Chamber	No.2
Date	October 2, 2022
Temperature / Humidity	24 deg. C / 52 % RH
Engineer	Nachi Konegawa (1 GHz - 10 GHz)
Mode	Tx 11ac-40 5795 MHz

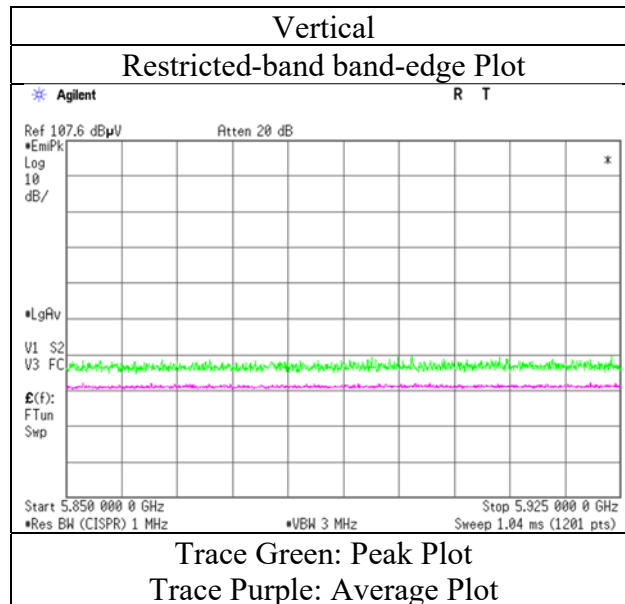
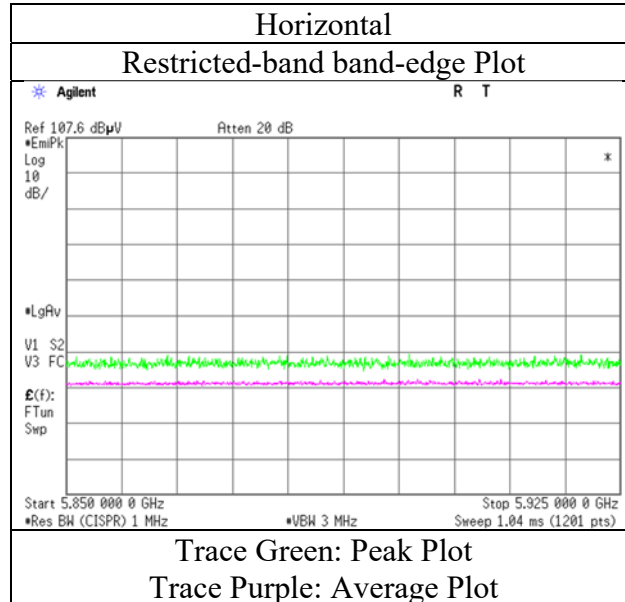

* The measurement was conducted for a sufficiently long enough time to detect any possible spurious emissions.
Final result of restricted band edge was shown in tabular data.

Radiated Spurious Emission

Test place	Ise EMC Lab.	
Semi Anechoic Chamber	No.2	No.2
Date	September 30, 2022	October 5, 2022
Temperature / Humidity	22 deg. C / 55 % RH	26 deg. C / 43 % RH
Engineer	Keiya Ido	Keiya Ido
	(1 GHz - 10 GHz)	(10 GHz - 40 GHz)
Mode	Tx 11ac-80 5210 MHz	

Polarity [Hori/Vert]	Frequency [MHz]	Reading (QP / PK) [dBuV]	Reading (AV) [dBuV]	Ant. Factor [dB/m]	Loss [dB]	Gain [dB]	Duty Factor [dB]	Result (QP / PK) [dBuV/m]	Result (AV) [dBuV/m]	Limit (QP / PK) [dBuV/m]	Limit (AV) [dBuV/m]	Margin (QP / PK) [dB]	Margin (AV) [dB]	Remark
Hori.	5150.0	44.6	34.3	31.7	5.4	34.1	3.8	47.6	41.3	73.9	53.9	26.3	12.6	*1)
Hori.	5350.0	46.7	35.9	31.6	5.5	34.0	3.8	49.8	42.8	73.9	53.9	24.1	11.1	*1)
Hori.	10420.0	44.8	-	39.2	-2.4	34.5	-	47.1	-	68.2	-	21.1	-	Floor noise
Hori.	15630.0	45.0	37.2	37.2	-0.8	33.6	-	48.0	40.2	73.9	53.9	26.0	13.7	Floor noise
Vert.	5150.0	43.0	34.3	31.7	5.4	34.1	3.8	46.1	41.3	73.9	53.9	27.8	12.6	*1)
Vert.	5350.0	43.9	34.4	31.6	5.5	34.0	3.8	47.0	41.3	73.9	53.9	27.0	12.6	*1)
Vert.	10420.0	44.7	-	39.2	-2.4	34.5	-	47.0	-	68.2	-	21.2	-	Floor noise
Vert.	15630.0	45.0	37.0	37.2	-0.8	33.6	-	48.0	40.0	73.9	53.9	25.9	13.9	Floor noise

Result (QP / PK) = Reading + Ant Factor + Loss (Cable+Attenuator+Filter+Distance factor(above 1 GHz)) - Gain(Amplifier)

Result (AV) = Reading + Ant Factor + Loss (Cable+Attenuator+Filter+Distance factor(above 1 GHz)) - Gain(Amplifier) + Duty factor

*Other frequency noises omitted in this report were not seen or had enough margin (more than 20 dB).

*QP detector was used up to 1GHz.

*1) Not Out of Band emission(Leakage Power)

Distance factor: 1 GHz - 10 GHz $20\log(3.6\text{ m} / 3.0\text{ m}) = 1.59\text{ dB}$
 10 GHz - 40 GHz $20\log(1.0\text{ m} / 3.0\text{ m}) = -9.5\text{ dB}$

Radiated Spurious Emission

Test place	Ise EMC Lab.
Semi Anechoic Chamber	No.2
Date	September 30, 2022
Temperature / Humidity	22 deg. C / 55 % RH
Engineer	Keiya Ido
	(1 GHz - 10 GHz)
Mode	Tx 11ac-80 5210 MHz

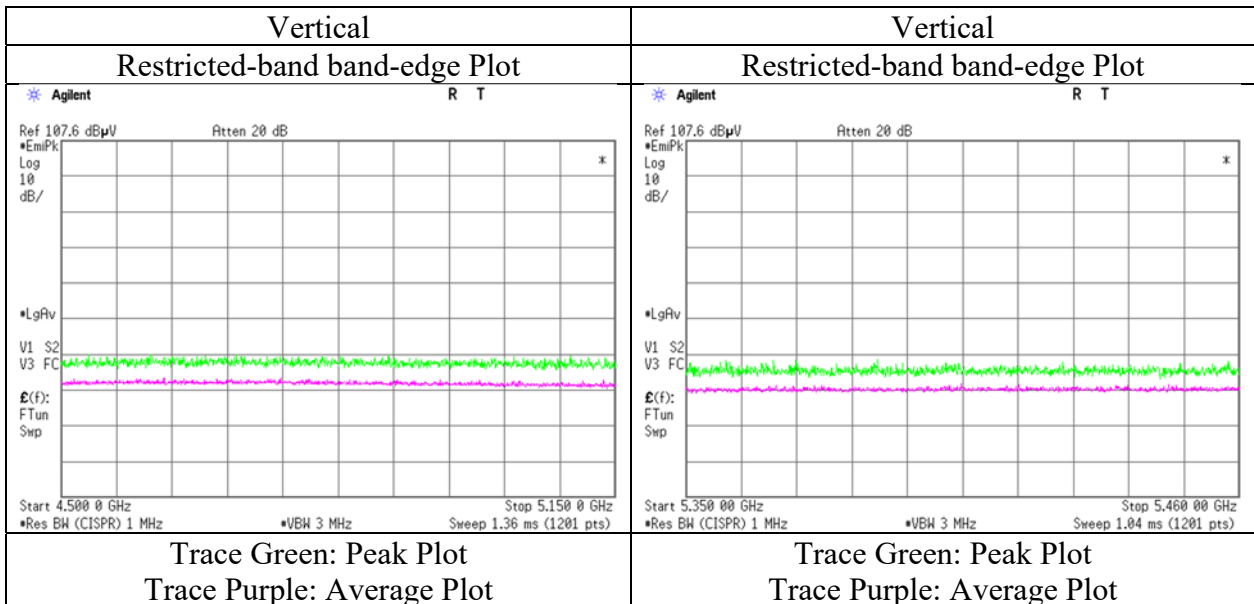
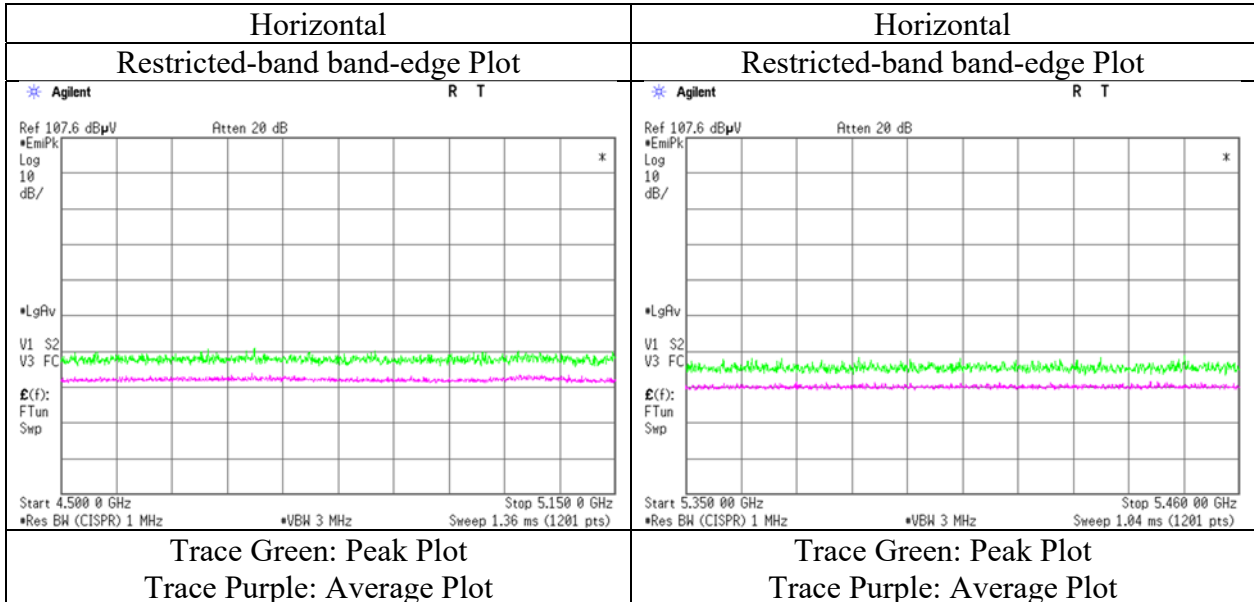

* The measurement was conducted for a sufficiently long enough time to detect any possible spurious emissions.
Final result of restricted band edge was shown in tabular data.

Radiated Spurious Emission

Test place	Ise EMC Lab.	
Semi Anechoic Chamber	No.2	No.2
Date	October 2, 2022	October 5, 2022
Temperature / Humidity	24 deg. C / 52 % RH	26 deg. C / 43 % RH
Engineer	Nachi Konegawa	Keiya Ido
	(1 GHz - 10 GHz)	(10 GHz - 40 GHz)
Mode	Tx 11ac-80 5775 MHz	

Polarity [Hori/Vert]	Frequency [MHz]	Reading (QP / PK) [dBuV]	Reading (AV) [dBuV]	Ant. Factor [dB/m]	Loss [dB]	Gain [dB]	Duty Factor [dB]	Result (QP / PK) [dBuV/m]	Result (AV) [dBuV/m]	Limit (QP / PK) [dBuV/m]	Limit (AV) [dBuV/m]	Margin (QP / PK) [dB]	Margin (AV) [dB]	Remark
Hori.	5650.0	46.3	-	31.8	5.6	33.9	-	49.7	-	68.2	-	18.5	-	
Hori.	5700.0	45.0	-	31.9	5.6	33.9	-	48.6	-	105.2	-	56.6	-	
Hori.	5720.0	46.2	-	31.9	5.6	33.9	-	49.7	-	110.8	-	61.1	-	
Hori.	5725.0	47.0	-	31.9	5.6	33.9	-	50.6	-	122.2	-	71.6	-	
Hori.	5850.0	44.9	-	32.2	5.6	33.9	-	48.8	-	122.2	-	73.4	-	
Hori.	5855.0	43.3	-	32.2	5.6	33.9	-	47.2	-	110.8	-	63.6	-	
Hori.	5875.0	43.8	-	32.2	5.7	33.9	-	47.7	-	105.2	-	57.5	-	
Hori.	5925.0	43.2	-	32.3	5.7	33.9	-	47.2	-	68.2	-	21.0	-	
Hori.	11550.0	42.1	34.0	39.3	-1.8	33.9	-	45.7	37.6	73.9	53.9	28.2	16.3	Floor noise
Hori.	17325.0	44.5	-	43.1	-0.3	33.0	-	54.3	-	68.2	-	13.9	-	Floor noise
Vert.	5650.0	44.1	-	31.8	5.6	33.9	-	47.6	-	68.2	-	20.7	-	
Vert.	5700.0	43.6	-	31.9	5.6	33.9	-	47.1	-	105.2	-	58.1	-	
Vert.	5720.0	43.4	-	31.9	5.6	33.9	-	47.0	-	110.8	-	63.8	-	
Vert.	5725.0	44.2	-	31.9	5.6	33.9	-	47.8	-	122.2	-	74.4	-	
Vert.	5850.0	43.2	-	32.2	5.6	33.9	-	47.1	-	122.2	-	75.1	-	
Vert.	5855.0	43.2	-	32.2	5.6	33.9	-	47.1	-	110.8	-	63.7	-	
Vert.	5875.0	42.7	-	32.2	5.7	33.9	-	46.7	-	105.2	-	58.5	-	
Vert.	5925.0	42.6	-	32.3	5.7	33.9	-	46.6	-	68.2	-	21.6	-	
Vert.	11550.0	42.1	34.0	39.3	-1.8	33.9	-	45.6	37.6	73.9	53.9	28.3	16.3	Floor noise
Vert.	17325.0	44.5	-	43.1	-0.3	33.0	-	54.3	-	68.2	-	13.9	-	Floor noise

Result (QP / PK) = Reading + Ant Factor + Loss (Cable+Attenuator+Filter+Distance factor(above 1 GHz)) - Gain(Amplifier)

Result (AV) = Reading + Ant Factor + Loss (Cable+Attenuator+Filter+Distance factor(above 1 GHz)) - Gain(Amplifier) + Duty factor

*Other frequency noises omitted in this report were not seen or had enough margin (more than 20 dB).

*QP detector was used up to 1GHz.

Distance factor: 1 GHz - 10 GHz 20log(3.6 m / 3.0 m) = 1.59 dB
 10 GHz - 40 GHz 20log(1.0 m / 3.0 m) = -9.5 dB

Radiated Spurious Emission

Test place	Ise EMC Lab.
Semi Anechoic Chamber	No.2
Date	October 2, 2022
Temperature / Humidity	24 deg. C / 52 % RH
Engineer	Nachi Konegawa (1 GHz - 10 GHz)
Mode	Tx 11ac-80 5775 MHz

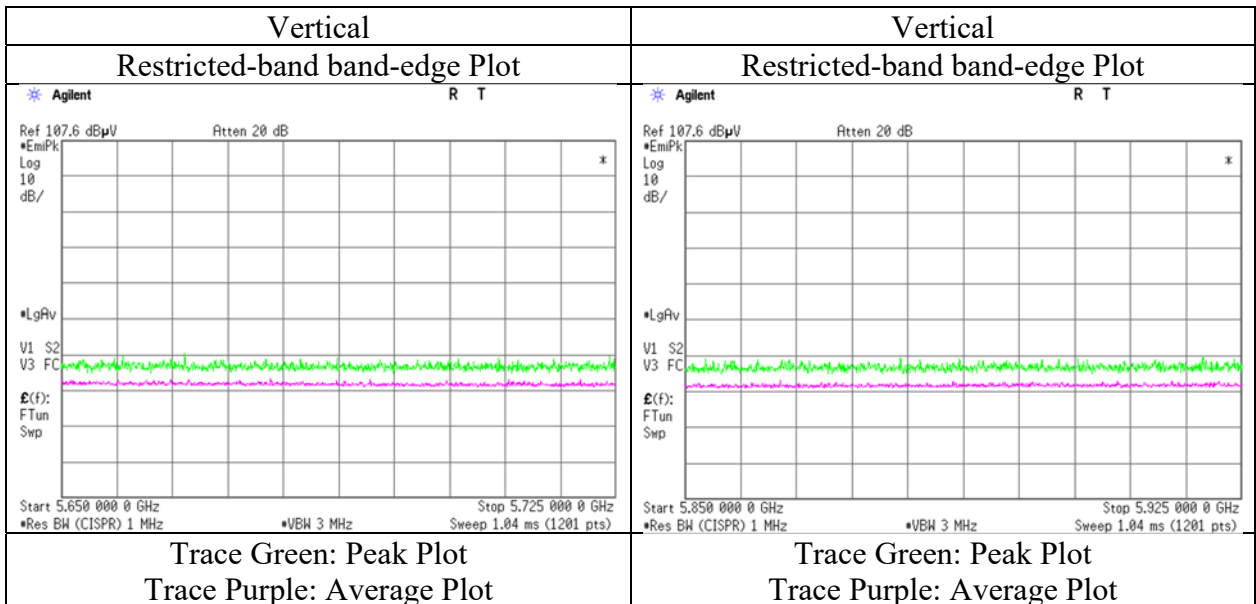
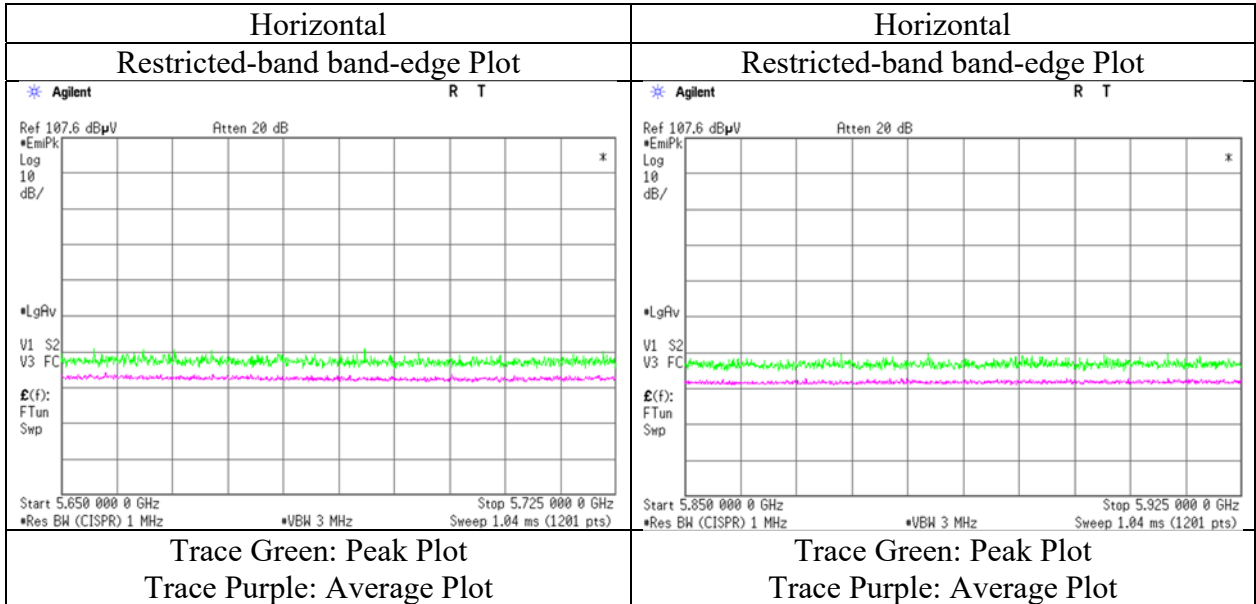

* The measurement was conducted for a sufficiently long enough time to detect any possible spurious emissions.
Final result of restricted band edge was shown in tabular data.

Radiated Spurious Emission
(Plot data, Worst case mode for Maximum Conducted Output Power)

Test place	Ise EMC Lab.		
Semi Anechoic Chamber	No.2	No.2	No.2
Date	September 30, 2022	October 5, 2022	October 6, 2022
Temperature / Humidity	22 deg. C / 55 % RH	24 deg. C / 50 % RH	22 deg. C / 42 % RH
Engineer	Keiya Ido	Hiroyuki Furutaka	Keiya Ido
	(1 GHz - 10 GHz)	(10 GHz - 40 GHz)	(Below 1 GHz)
Mode	Tx 11ac-20 5180 MHz		

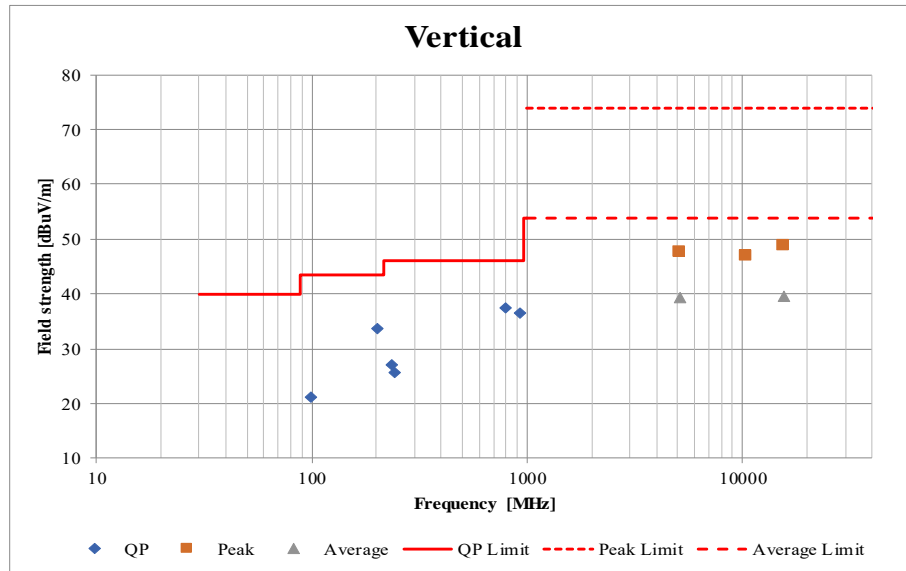
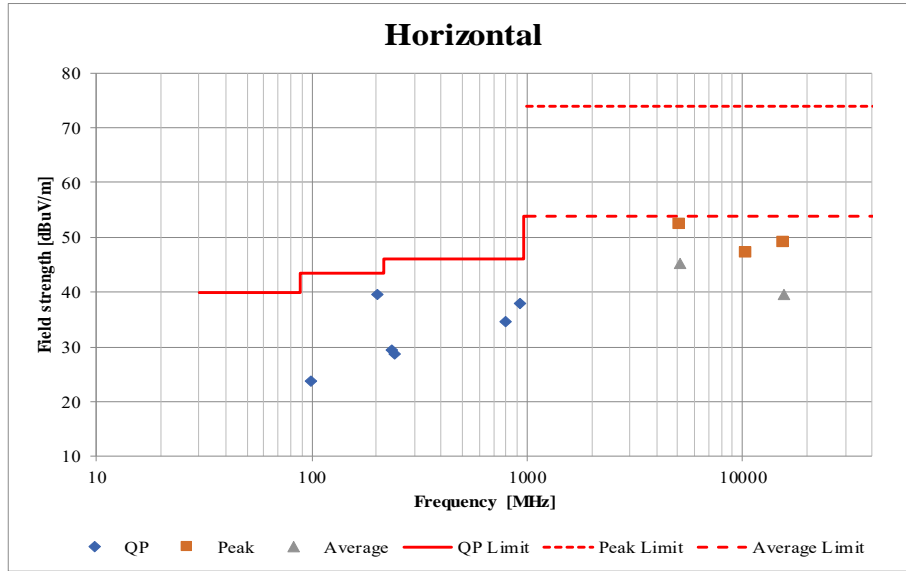

*These plots data contains sufficient number to show the trend of characteristic features for EUT.

Conducted Spurious Emission

Test place	Ise EMC Lab. No.4 Measurement Room
Date	October 11, 2022
Temperature / Humidity	23 deg. C / 55 % RH
Engineer	Takumi Nishida
Mode	Tx 11ac-20 5180 MHz

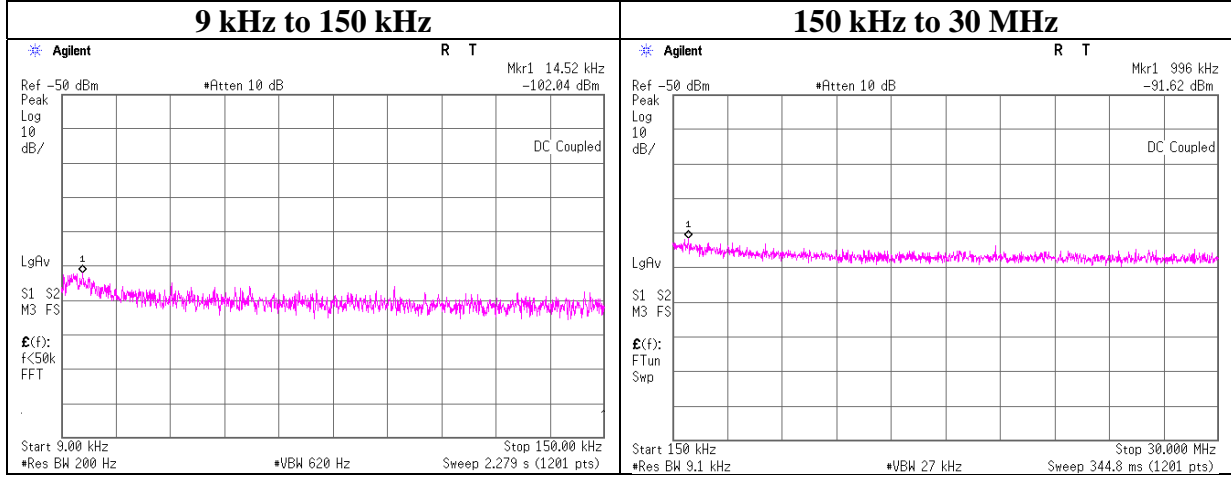

Frequency [kHz]	Reading [dBm]	Cable Loss [dB]	Attenuator Loss [dB]	Antenna Gain [dBi]	N (Number of Output)	EIRP [dBm]	Distance [m]	Ground bounce [dB]	E (field strength) [dBuV/m]	Limit [dBuV/m]	Margin [dB]	Remark
14.52	-102.04	0.02	9.84	3.79	1.00	-88.39	300	6.00	-27.13	44.30	71.43	
996.00	-91.62	0.27	9.92	3.79	1.00	-77.64	30	6.00	3.62	27.60	23.98	

$E \text{ [dBuV/m]} = \text{EIRP [dBm]} - 20 \log(\text{Distance [m]}) + \text{Ground bounce [dB]} + 104.80 \text{ [dBuV/m]}$

$\text{EIRP [dBm]} = \text{Reading [dBm]} + \text{Cable loss [dB]} + \text{Attenuator Loss [dB]} + \text{Antenna gain [dBi]} + 10 * \log(N)$

N: Number of output

APPENDIX 2: Test Instruments

Test Equipment

Test Item	Local ID	LIMS ID	Description	Manufacturer	Model	Serial	Last Calibration Date	Cal Int
RE	COTS-MEMI-02	178648	EMI measurement program	TSJ (Techno Science Japan)	TEPTO-DV	-	-	-
RE	MAEC-02	142004	AC2_Semi Anechoic Chamber(NSA)	TDK	Semi Anechoic Chamber 3m	DA-06902	05/30/2022	24
RE	MAEC-02-SVSWR	142006	AC2_Semi Anechoic Chamber(SVSWR)	TDK	Semi Anechoic Chamber 3m	DA-06902	04/09/2021	24
RE	MAT-112	220646	Attenuator	Huber+Suhner	6806 N-50-1	-	06/07/2022	12
RE	MBA-05	141425	Biconical Antenna	Schwarzbeck Mess-Elektronik OHG	VHA9103+BBA9106	VHA 91031302	08/26/2022	12
RE	MCC-12	141317	Coaxial Cable	UL Japan	-	-	09/27/2022	12
RE	MCC-176	141279	Microwave Cable	Junkosha	MMX221-00500DMSDMS	1502S303	03/15/2022	12
RE	MCC-218	141394	Microwave Cable	Junkosha	MWX221	1607S141(1 m) / 1608S264(5 m)	09/12/2022	12
RE	MCC-54	141325	Microwave Cable	Suhner	SUCOFLEX101	2873(1m) / 2876(5m)	03/17/2022	12
RE	MHA-06	141512	Horn Antenna 1-18GHz	Schwarzbeck Mess-Elektronik OHG	BBHA9120D	254	10/21/2021	12
RE	MHA-17	141506	Horn Antenna 15-40GHz	Schwarzbeck Mess-Elektronik OHG	BBHA9170	BBHA9170307	07/22/2022	12
RE	MHF-16	141406	High Pass Filter 7-20GHz	TOKIMEC	TF37NCCA	7001	09/07/2022	12
RE	MJM-27	142228	Measure	KOMELON	KMC-36	-	-	-
RE	MLA-21	141265	Logperiodic Antenna (200-1000MHz)	Schwarzbeck Mess-Elektronik OHG	VUSLP9111B	9111B-190	07/30/2022	12
RE	MMM-01	141542	Digital Tester	Fluke Corporation	FLUKE 26-3	78030611	08/12/2022	12
RE	MOS-41	192300	Thermo-Hygrometer	CUSTOM. Inc	CTH-201	0013	12/19/2021	12
RE	MPA-10	141579	Pre Amplifier	Keysight Technologies Inc	8449B	3008A02142	02/22/2022	12
RE	MPA-22	141588	Pre Amplifier	MITEQ, Inc	AMF-6F-2600400-33-8P / AMF-4F-2600400-33-8P	1871355 /1871328	09/29/2022	12
RE	MPA-24	141594	Pre Amplifier	Keysight Technologies Inc	8447D	2944A10150	02/25/2022	12
RE	MSA-04	141885	Spectrum Analyzer	Keysight Technologies Inc	E4448A	US44300523	11/10/2021	12
RE	MTR-03	141942	Test Receiver	Rohde & Schwarz	ESCI	100300	07/29/2022	12
AT	COTS-MPM	141176	measurement software	Other	All	-	-	-
AT	MAT-10	141156	Attenuator(10dB)	Weinschel Corp	2	BL1173	11/09/2021	12
AT	MAT-20	141173	Attenuator(10dB) (above1GHz)	HIROSE ELECTRIC CO.,LTD.	AT-110	-	12/08/2021	12
AT	MAT-89	141419	Attenuator	Weinschel Associates	WA56-10	56100305	2023/05/18	12
AT	MCC-144	141414	Microwave Cable	Junkosha	MWX221	1207S407	2022/08/01	12
AT	MCC-245	197220	Microwave cable	Huber+Suhner	SF126E/11PC35/11PC35/2000MM	537003/126E	03/17/2022	12
AT	MCC-38	141395	Coaxial Cable	UL Japan	-	-	11/19/2021	12
AT	MMM-10	141545	DIGITAL HiTESTER	HIOKI E.E. CORPORATION	3805	51201148	01/16/2022	12
AT	MMM-16	141360	DIGITAL HiTESTER	HIOKI E.E. CORPORATION	3805	70900532	01/16/2022	12
AT	MMM-17	141557	DIGITAL HiTESTER	HIOKI E.E. CORPORATION	3805	70900530	2023/01/18	12
AT	MOS-15	141562	Thermo-Hygrometer	CUSTOM. Inc	CTH-201	0010	01/10/2022	12
AT	MOS-28	141567	Thermo-Hygrometer	CUSTOM. Inc	CTH-201	0008	2023/01/13	12
AT	MOS-34	141572	Thermo-Hygrometer	CUSTOM. Inc	CTH-201	3401	01/10/2022	12
AT	MPM-16	141812	Power Meter	Keysight Technologies Inc	8990B	MY51000271	08/05/2022	12
AT	MPM-17	141813	Power Meter	Raditec (Formerly DARE!!Instruments)	RPR3006W	14I00048SNO081	11/01/2021	12
AT	MPSE-22	141842	Power sensor	Keysight Technologies Inc	N1923A	MY54070003	08/05/2022	12
AT	MSA-03	141884	Spectrum Analyzer	Keysight Technologies Inc	E4448A	MY44020357	03/31/2022	12
AT	MSA-14	141901	Spectrum Analyzer	Keysight Technologies Inc	E4440A	MY48250080	01/10/2022	12
AT	MSA-16	141903	Spectrum Analyzer	Keysight Technologies Inc	E4440A	MY46186390	2023/01/16	12

*Hyphens for Last Calibration Date and Cal Int (month) are instruments that Calibration is not required (e.g. software), or instruments checked in advance before use.

The expiration date of the calibration is the end of the expired month.

As for some calibrations performed after the tested dates, those test equipment have been controlled by means of an unbroken chains of calibrations.

All equipment is calibrated with valid calibrations. Each measurement data is traceable to the national or international standards.

Test item:

RE: Radiated Emission

AT: Antenna Terminal Conducted test