



EMI TEST REPORT

Test Report No. : 23JE0007-HO-9

Applicant : Fujitsu Ten Limited
Type of Equipment : Display
Model No. : 134000-268
Test standard : FCC Part 15 Subpart C
Section 15.247
FCC ID : BAB134000-268
Test Result : Complied

1. This test report shall not be reproduced in full or partial, without the written approval of UL Apex Co., Ltd.
2. The results in this report apply only to the sample tested.
3. This equipment is in compliance with above regulation. We hereby certify that the data contain a true representation of the EMC profile.
4. The test results in this report are traceable to the national or international standards.
5. This test report does not constitute an endorsement by NIST/NVLAP or U.S. Government.

Date of test : May 15 and 27, 2003

Tested by : 
Hiroka Umeyama
EMC Section

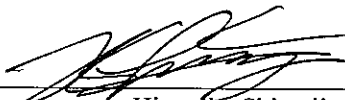
Approved by : 
Hironobu Shimoji
Group Leader of EMC Section

CONTENTS

	PAGE
SECTION 1: Client information	3
SECTION 2: Equipment under test (E.U.T.)	3
SECTION 3: Test specification, procedures and results	4
SECTION 4: Operation of E.U.T. during testing	6
SECTION 5: Carrier Frequency Separation , Section 15.247(a)(1)	7
SECTION 6: 20dB Bandwidth, Section 15.247(a)(1)	7
SECTION 7: Number of Hopping Frequency, Section 15.247(a)(1)(iii)	7
SECTION 8: Dwell time, Section 15.247(a)(1)(iii)	7
SECTION 9: Maximum Peak Output Power, Section 15.247(b)(1)	7
SECTION 10: Band Edge compliance, Section 15.247(c)	7
SECTION 11: Spurious Emission, Section 15.247(c)	8
Contents of Appendixes	9
APPENDIX 1: Photographs of test setup	10
APPENDIX 2: Test instruments	11
APPENDIX 3: Data of EMI test	12

UL Apex Co., Ltd.

Head Office EMC Lab.

4383-326 Asama-cho, Ise-shi, Mie-ken 516-0021 JAPAN

Telephone : +81 596 24 8116

Facsimile : +81 596 24 8124

SECTION 1: Client information

Company name : Fujitsu Ten Limited
Brand name : -
Address : 2-28, Goshō-dori 1-chome, Hyogo-ku, Kobe 652-8510 Japan
Telephone Number : +81 78 682 2159
Facsimile Number : +81 78 671 7160
Contact Person : Naoto Nishimura

SECTION 2: Equipment under test (E.U.T.)

2.1 Identification of E.U.T.

Type of Equipment : Display
Model No. : 134000-268
Serial No. : 1G-2 1
Rating : DC 13.2V, 3.0 A and below
Country of Manufacture : Japan
Receipt Date of Sample : May 8, 2003
Condition of EUT : Production prototype

2.2 Product description

Fujitsu Ten Limited, Model: 134000-268 (referred to as the EUT in this report) is a Display.
The clock frequency used in EUT is 8.3076MHz, 12.55MHz for Microprocessor, 19.17MHz for Echo canceller, and 50kHz, 196.1kHz, 6.29MHz, 14.745MHz for other communication clocks, 86.5kHz for D-D converter, 55kHz for Inverter, 150Hz for Back light duty, 15.734kHz for Synchronous separation, 500kHz, 8kHz, 115.2kHz for Bluetooth and 27MHz, 15.734kHz for Drawing dot clock.

Frequency band : from 2400 MHz to 2483.5 MHz
Frequency of operation : 2402MHz – 2480MHz
Number of channels and channel spacing : 79ch, 1MHz
Type of Modulation : FSK, FHSS
Antenna Type : Chip antenna (Murata, LDA923G5020D-210)
Antenna Gain : 1.6 dBi
Power Supply : DC 12V 10.5V-16V
Operating temperature Range : -30 deg.C. to 65 deg.C.

UL Apex Co., Ltd.

Head Office EMC Lab.

4383-326 Asama-cho, Ise-shi, Mie-ken 516-0021 JAPAN

Telephone : +81 596 24 8116

Facsimile : +81 596 24 8124

SECTION 3: Test specification, procedures & results

3.1 Test Specification

Test Specification : FCC Part15 Subpart C
Title : FCC 47CFR Part15 Radio Frequency Device Subpart C Intentional Radiators
Section 15.247 Operation within the bands 902-928MHz, 2400-2483.5MHz, and 5725-5850MHz

3.2 Procedures and results

No.	Item	Test Procedure	Specification	Remarks	Deviation	Worst margin	Results
1	Conducted emission	ANSI C63.4:2001	Section 15.207	-	Excluded*1)	N/A	N/A
2	Carrier Frequency Separation	ANSI C63.4:2001	Section15.247(a)(1)	Conducted	N/A	-	Complied
3	20dB Bandwidth	ANSI C63.4:2001	Section15.247(a)(1)	Conducted	N/A	-	Complied
4	Number of Hopping Frequency	ANSI C63.4:2001	Section15.247(a)(1)(iii)	Conducted	N/A	-	Complied
5	Dwell time	ANSI C63.4:2001	Section15.247(a)(1)(iii)	Conducted	N/A	-	Complied
6	Maximum Peak Output Power	ANSI C63.4:2001	Section15.247(b)(1)	Conducted	N/A	-	Complied
7	Band Edge Compliance	ANSI C63.4:2001	Section15.247(c)	Conducted	N/A	-	Complied
8	Spurious Emission	ANSI C63.4:2001	Section15.247(c)	Conducted/ Radiated	N/A	12.3dB 4960.0MHz Vertical	Complied

*1)The test is not applicable since the EUT does not have AC Mains.

*These tests were performed without any deviations from test procedure except for additions or exclusions.

*These tests were also referred to FCC Public Notice DA 00-705 "Guidance on Measurement for Frequency Hopping Spread Spectrum Systems".

3.3 Confirmation

UL Apex Co., Ltd. hereby confirms that E.U.T., in the configuration tested, complies with the specifications FCC Part 15 Subpart C Section 15.207 and 15.247.

UL Apex Co., Ltd.

Head Office EMC Lab.

4383-326 Asama-cho, Ise-shi, Mie-ken 516-0021 JAPAN

Telephone : +81 596 24 8116

Facsimile : +81 596 24 8124

3.4 Uncertainty

Spurious Emission (Radiated)

The measurement uncertainty (with a 95% confidence level) for this test using Biconical antenna is ± 4.5 dB.

The measurement uncertainty (with a 95% confidence level) for this test using Logperiodic antenna is ± 5.2 dB.

The measurement uncertainty (with a 95% confidence level) for this test using Horn antenna is ± 6.6 dB.

■ The result is within Head Office EMC lab's uncertainty.

□ The data listed in this test report has enough margin.

Other test except Conducted Emission and Spurious Emission (Radiated)

The measurement uncertainty (with a 95% confidence level) for this test was ± 3.0 dB.

□ The result is within Head Office EMC lab's uncertainty.

■ The data listed in this test report has enough margin.

3.5 Test Location

UL Apex Co., Ltd. Head Office EMC Lab.

No.2 semi Anechoic chamber and No.3 measurement room.

4383-326 Asama-cho, Ise-shi, Mie-ken 516-0021 JAPAN

Telephone : +81 596 24 8116

Facsimile : +81 596 24 8124

This semi anechoic chamber has been fully described in a report submitted to FCC office, and listed on June 05, 2002.

(Registration number: No.2 :846015 Industry Canada: No.2 : IC4247-2)

*NVLAP Lab. code: 200572-0

3.6 Test set up, Test instruments and Data of EMI

Refer to APPENDIX 1 to 3.

UL Apex Co., Ltd.

Head Office EMC Lab.

4383-326 Asama-cho, Ise-shi, Mie-ken 516-0021 JAPAN

Telephone : +81 596 24 8116

Facsimile : +81 596 24 8124

SECTION 4: Operation of E.U.T. during testing

4.1 Operating Modes

The EUT exercise program used during radiated and conducted testing was designed to exercise the various system components in a manner similar to typical use.

The sequence is used : 1. Transmitting mode (ch1:2402MHz, ch6:2441MHz, ch11:2480MHz)

Justification: The system was configured in typical fashion (as a customer would normally use it) for testing.

4.2 Configuration and peripherals

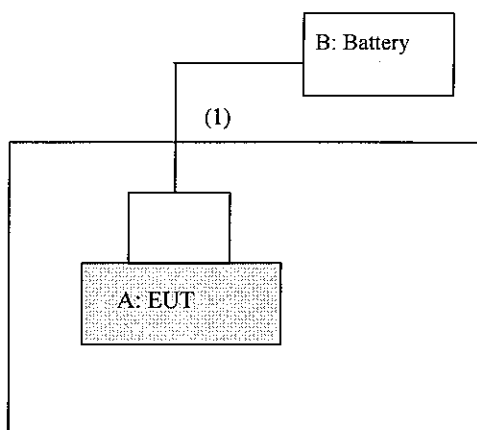

* Cabling was taken into consideration and test data was taken under worst case conditions.

Description of EUT and support equipment

No.	Item	Model number	Serial number	Manufacturer	FCC ID	Remark
A	Display	134000-268	1G-2 1	Tochigi Fujitsu Ten	BAB134000-268	-
B	Battery	B19L	161001C	Panasonic	-	-

List of cables used

No.	Name	Length (m)	Shield	Backshell Material
(1)	DC cable	5.0	N	Polyvinyl chloride

UL Apex Co., Ltd.

Head Office EMC Lab.

4383-326 Asama-cho, Ise-shi, Mie-ken 516-0021 JAPAN

Telephone : +81 596 24 8116

Facsimile : +81 596 24 8124

SECTION 5: Carrier Frequency Separation , Section 15.247(a)(1)

Test Procedure

The carrier frequency separation was measured with a spectrum analyzer connected to the antenna port.

Test data : APPENDIX 2
Test result : Pass
Test instruments : MBTR10, MCC-04

SECTION 6: 20dB Bandwidth , Section 15.247(a)(1)

Test Procedure

The 20dB bandwidth was measured with a spectrum analyzer connected to the antenna port.

Test data : APPENDIX 2
Test result : Pass
Test instruments : MBTR10, MCC-04

SECTION 7: Number of Hopping Frequency, Section 15.247(a)(1)(iii)

Test Procedure

The Number of Hopping Frequency was measured with a spectrum analyzer connected to the antenna port.

Test data : APPENDIX 2
Test result : Pass
Test instruments : MBTR10, MCC-04

SECTION 8: Dwell time, Section 15.247(a)(1)(iii)

Test Procedure

The Dwell time was measured with a spectrum analyzer connected to the antenna port.

Test data : APPENDIX 2
Test result : Pass
Test instruments : MBTR10, MCC-04

SECTION 9: Maximum Peak Output Power, Section 15.247(b)(1)

Test Procedure

The Maximum Peak Output Power was measured with a spectrum analyzer connected to the antenna port.

Test data : APPENDIX 2
Test result : Pass
Test instruments : MBTR10, MCC-04

SECTION 10: Band Edge Compliance, Section 15.247(c)

Test Procedure

The Band Edge Compliance was measured with a spectrum analyzer connected to the antenna port.

Test data : APPENDIX 2
Test result : Pass
Test instruments : MBTR10, MCC-04

UL Apex Co., Ltd.

Head Office EMC Lab.

4383-326 Asama-cho, Ise-shi, Mie-ken 516-0021 JAPAN

Telephone : +81 596 24 8116

Facsimile : +81 596 24 8124

SECTION 11: Spurious Emission , Section 15.247(c)

[Conducted]

Test Procedure

The Spurious Emission (Conducted) was measured with a spectrum analyzer connected to the antenna port.

Test data : **APPENDIX 2**
Test result : **Pass**
Test instruments : **MBTR10, MCC-04**

[Radiated]

Test Procedure

EUT was placed on a platform of nominal size, 1m by 1.5m, raised 80cm above the conducting ground plane. Test was made with the antenna positioned in both the horizontal and vertical planes of polarization.

The Radiated Electric Field Strength intensity has been measured in No.2 semi anechoic chamber (7.5x5.8x5.2m) with a ground plane and at a distance of 3m.

The measuring antenna height was varied between 1 to 4m and EUT was rotated a full revolution in order to obtain the maximum value of the electric field intensity.

The measurements were performed for both vertical and horizontal antenna polarization.

The maximum output power of EUT was confirmed as the worst case condition in the photo of APPENDIX.

Test data : **APPENDIX 2**
Test result : **Pass**
Test instruments : **MAT-07, MCC-12, MPA-04, MTR-02, SA-07, MBA-02, MLA-02, MCC-05, MHA-02, MHA-06, MPA-01, MCC-24, MCC-11**

UL Apex Co., Ltd.

Head Office EMC Lab.

4383-326 Asama-cho, Ise-shi, Mie-ken 516-0021 JAPAN

Telephone : +81 596 24 8116

Facsimile : +81 596 24 8124

Contents of Appendixes

APPENDIX 1: Photographs of test setup

Page 10 : Spurious Emission (Radiated)

APPENDIX 2: Test instruments

Page 11 : Test instruments

APPENDIX 3: Data of EMI test

Page 12-14 : Carrier Frequency Separation
Page 15-17 : 20dB Bandwidth
Page 18-21 : Number of Hopping Frequency
Page 22-26 : Dwell time
Page 27-29 : Maximum Peak Output Power
Page 30-32 : Band Edge Compliance
Page 33-44 : Spurious Emission

UL Apex Co., Ltd.

Head Office EMC Lab.

4383-326 Asama-cho, Ise-shi, Mie-ken 516-0021 JAPAN

Telephone : +81 596 24 8116

Facsimile : +81 596 24 8124

APPENDIX 1: Photographs of test setup

Spurious Emission (Radiated)

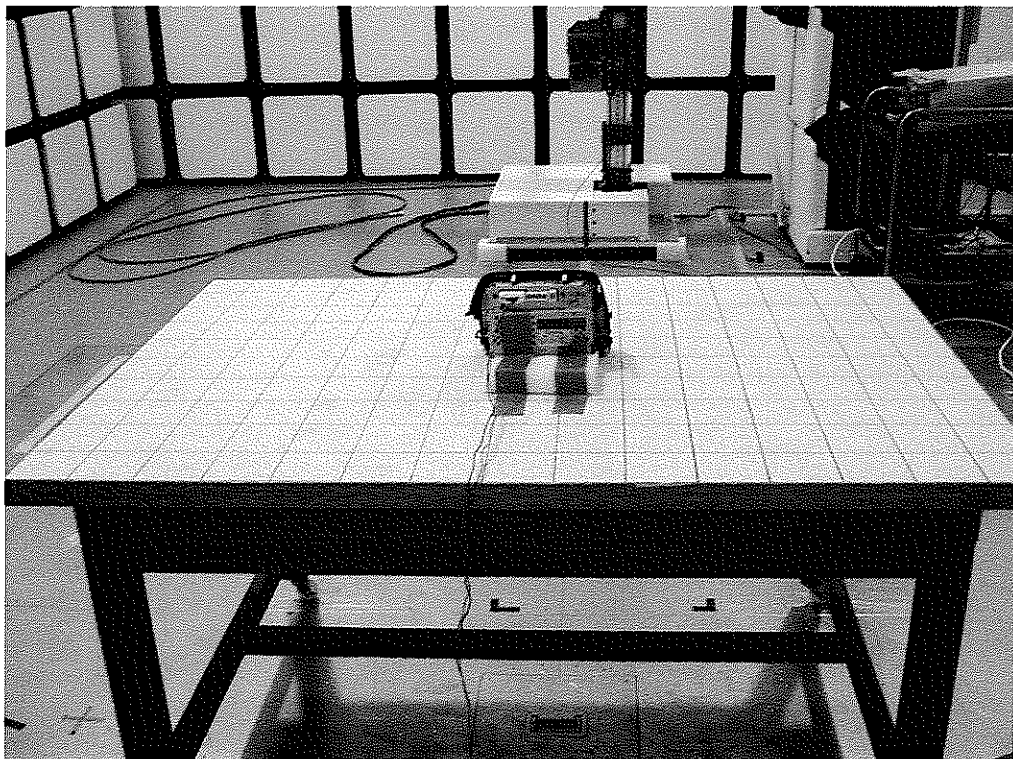
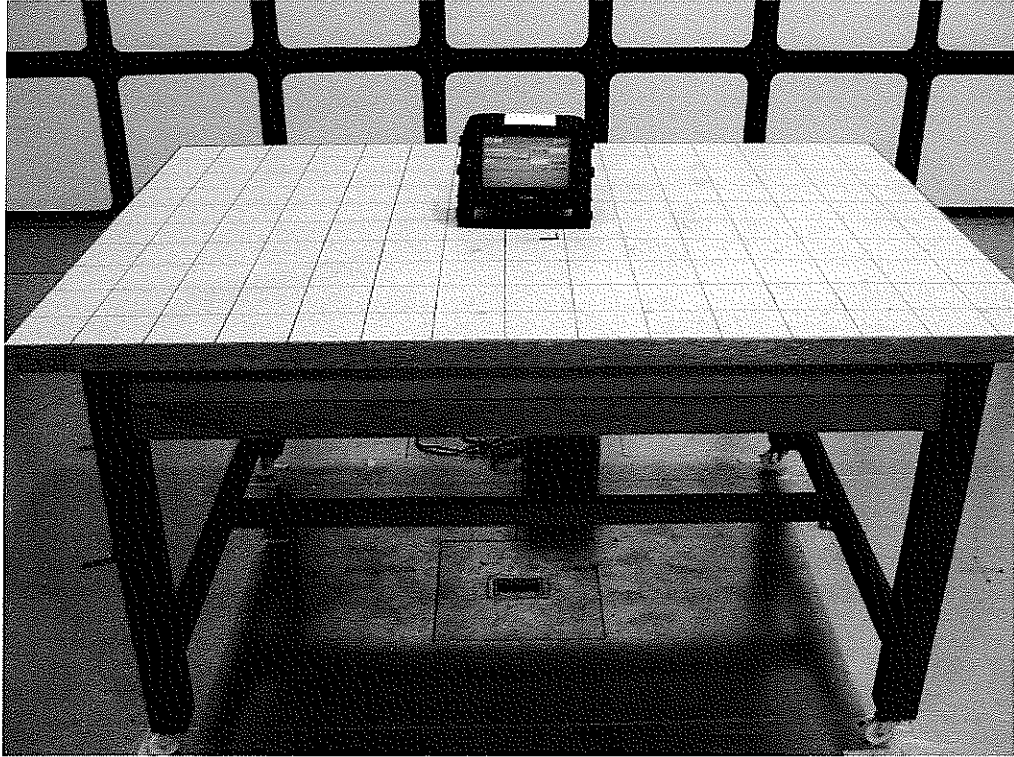

Test Report No :23JE0007-HO-9

APPENDIX 2
Test Instruments

EMI test equipment

Control No.	Instrument	Manufacturer	Model No	Test Item	Calibration Date * Interval(month)
MBTR10	Spectrum Analyzer	Rohde & Schwarz	FSP30	RE	2002/11/13 * 12
MCC-04	Microwave Cable	Storm	421-011	RE	2003/01/14 * 12
MTR-02	Test Receiver	Rohde & Schwarz	ESI40	RE	2002/11/01 * 12
MCC-12	Coaxial Cable	Fujikura/Agilent	MCC-12-01(8D-2W15m),MCC-12-02(5D-2W-0.7),MCC-12-03(5D-2W-0.8),MCC-12-04(5D-2W-1m),MCC-12-05(RF SW),MCC-12-06(RF SW),※MCC-12-07(5D-2W-0.4m)5/8追加	RE	2003/05/08 * 12
MCC-05	Microwave Cable	Storm	421-011	RE	2003/01/14 * 12
MCC-24	Microwave Cable	Storm	421-011	RE	2003/01/14 * 12
MHA-06	Horn Antenna	Schwarzbeck	BBHA9120D	RE	2003/01/11 * 12
MPA-01	Pre Amplifier	Agilent	8449B	RE	2003/02/08 * 12
MBA-02	Biconical Antenna	Schwarzbeck	BBA9106	RE	2003/04/28 * 12
MLA-02	Logperiodic Antenna	Schwarzbeck	USLP9143	RE	2003/04/28 * 12
MPA-04	Pre Amplifier	Agilent	8447D	RE	2003/03/13 * 12
MAT-07	Attenuator(6dB)	Weinschel Corp	2	RE	2002/12/24 * 12
MCC-11	Microwave coaxial cable	Suhner	SUCOFLEX 104	RE	2003/03/27 * 12
MHA-02	Horn Antenna	EMCO	3160-09	RE	2003/01/11 * 12
SA-07	Spectrum Analyzer	Advantest	R3265	RE	2002/12/24 * 12

All equipment is calibrated with traceable calibrations. Each calibration is traceable to the national or international standards.

Test Item:

RE: Radiated emission,

DATA OF CARRIER FREQUENCY SEPARATION

UL Apex Co., Ltd.
Head Office EMC Lab. No.3 Measurement Room

COMPANY	: Fujitsu Ten Limited	REPORT NO	: 23JE0007-HO - 9
EQUIPMENT	: Display	REGULATION	: Fcc Part15 Subpart C 15.247(a)(1)
MODEL	: 134000-268	TEST DISTANCE	: -
S/N	: 1G-2 1	DATE	: 05/27/2003
FCC ID	: BAB134000-268	TEMPERATURE	: 24°C
IC Number	: 2024B-134268	HUMIDITY	: 42%
POWER	: DC12V		
MODE	: Tx (Hopping on) /Inquiry		



 Engineer: Hiroka Umeyama

PK DETECT(S/A :span 3MHz, RBW 100kHz ,VBW 100kHz, sweep time AUTO)

CH	FREQ [MHz]	Channel separation [MHz]	Limit
Low	2402.0	0.984	>20dB Bandwidth and 25[kHz]
Mid	2441.0	0.978	>20dB Bandwidth and 25[kHz]
High	2480.0	1.000	>20dB Bandwidth and 25[kHz]
Inquiry	2441.0	2.000	>20dB Bandwidth and 25[kHz]

Carrier Frequency Separation :Tx(Hopping on)2402MHz

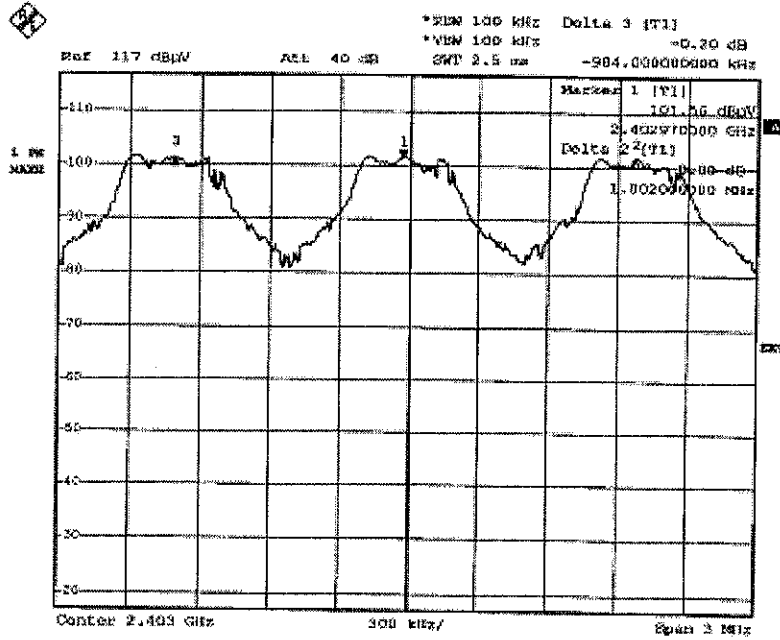

Date: 27.MAY.2003 11:58:37

Carrier Frequency Separation :Tx(Hopping on)2441MHz

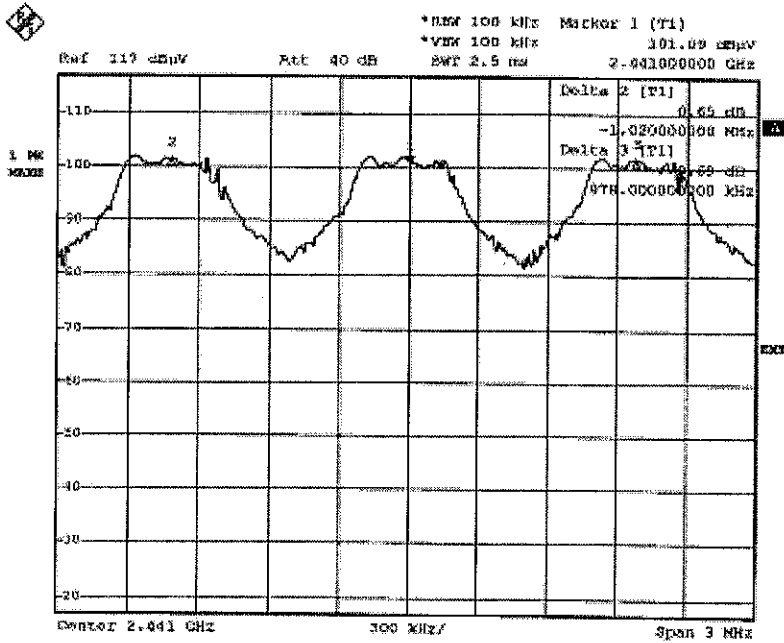

Date: 27.MAY.2003 12:05:26

Carrier Frequency Separation :Tx(Hopping on)2480MHz

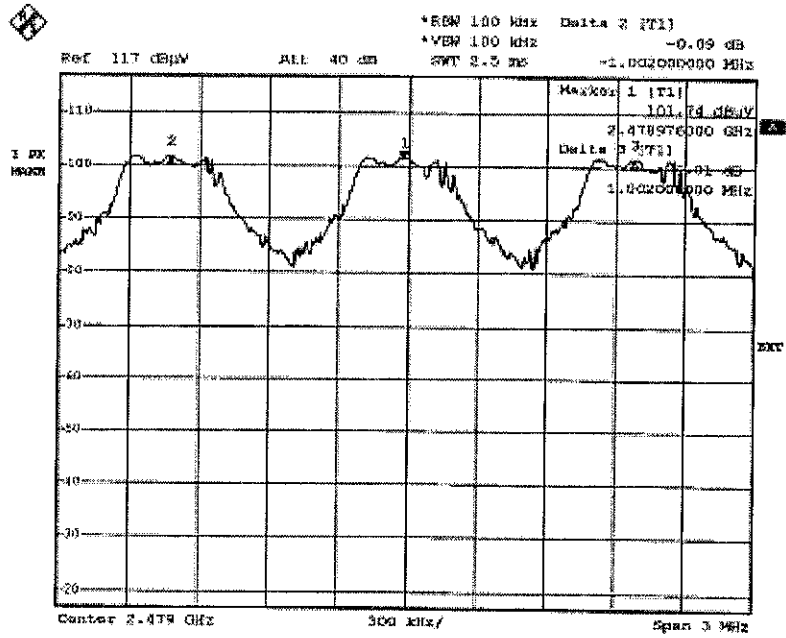

Date: 27.MAY.2003 12:19:20

Carrier Frequency Separation : Inquiry

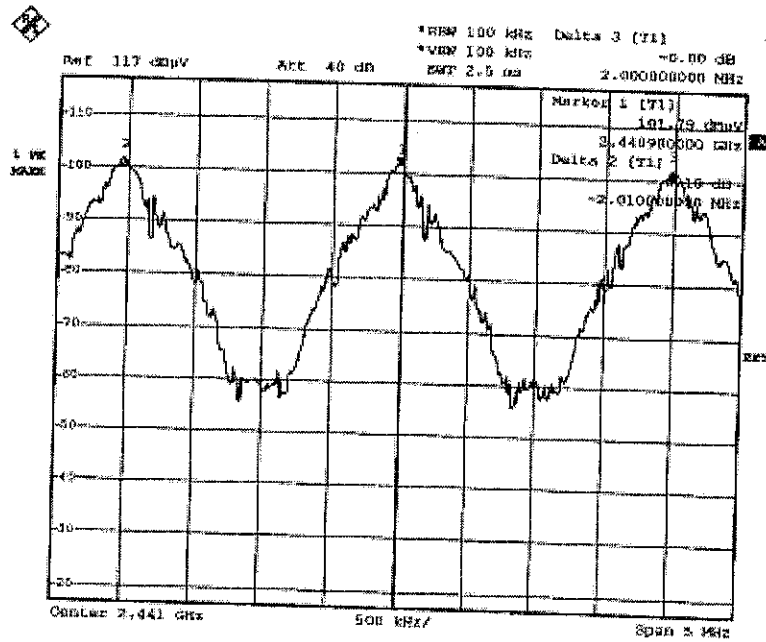

Date: 27.MAY.2003 12:16:45

DATA OF 20dB BANDWIDTH

UL Apex Co., Ltd.
Head Office EMC Lab. No.3 Measurement Room

COMPANY : Fujitsu Ten Limited
EQUIPMENT : Display
MODEL : 134000-268
S/N : 1G-2 1
FCC ID : BAB134000-268
IC Number : 2024B-134268
POWER : DC12V
MODE : Tx (Hopping off) /Inquiry

REPORT NO : 23JE0007-HO - 9
REGULATION : Fcc Part15 Subpart C 15.247(a)(1)
TEST DISTANCE : -
DATE : 05/27/2003
TEMPERATURE : 24°C
HUMIDITY : 42%

Engineer: Hiroka Umeyama

PK DETECT(S/A: span 3MHz, RBW 30kHz, VBW 30kHz, sweep time AUTO)

CH	FREQ	20dB Bandwidth	Limit
	[MHz]	[MHz]	[MHz]
Low	2402.0	0.744	1.0
Mid	2441.0	0.726	1.0
High	2480.0	0.732	1.0
Inquiry	2441.0	0.678	1.0

20dB Bandwidth:Tx(Hopping off)2402MHz

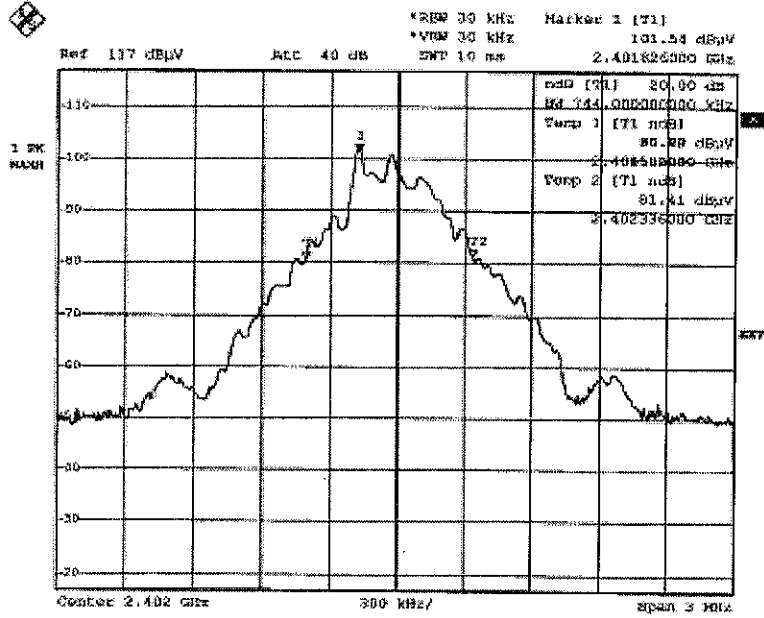

Date: 27.MAY.2003 11:30:05

20dB Bandwidth:Tx(Hopping off)2441MHz

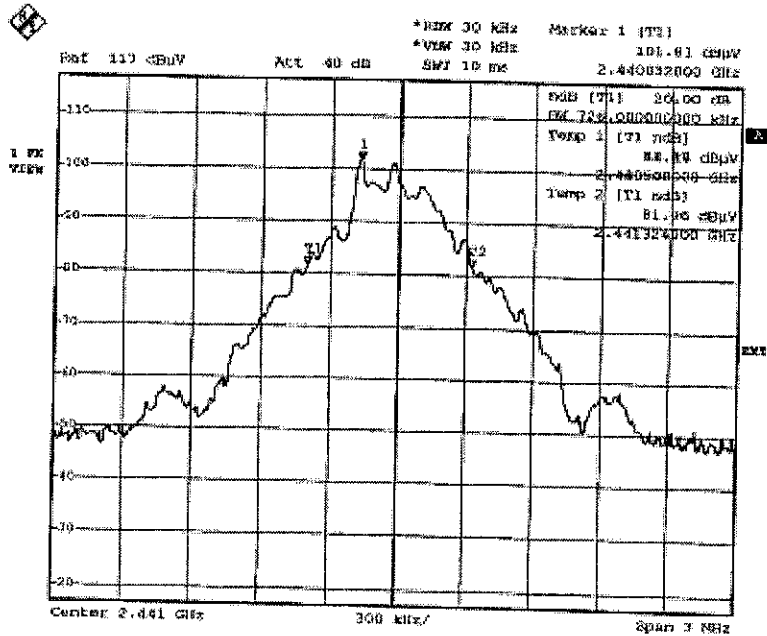

Date: 27.MAY.2003 11:31:22

20dB Bandwidth:Tx(Hopping off)2480MHz

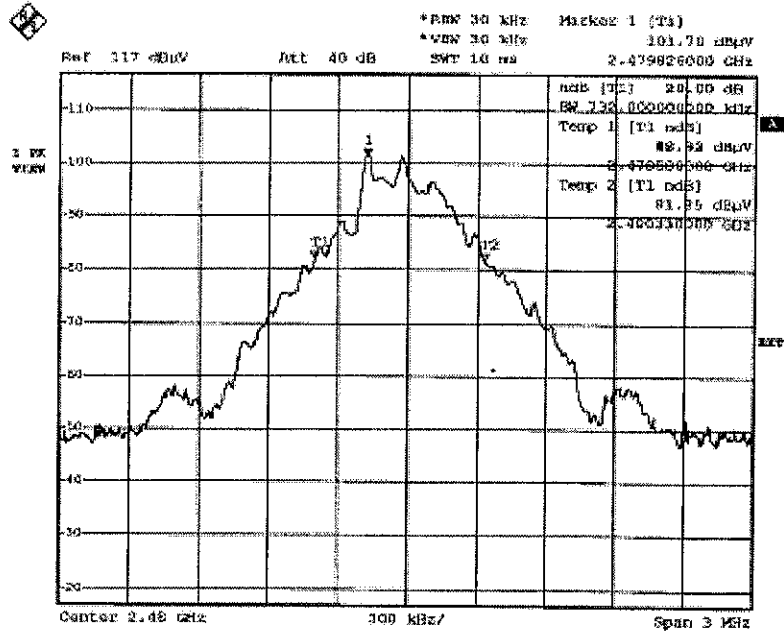

Date: 27.MAY.2003 11:33:04

20dB Bandwidth:Inquiry

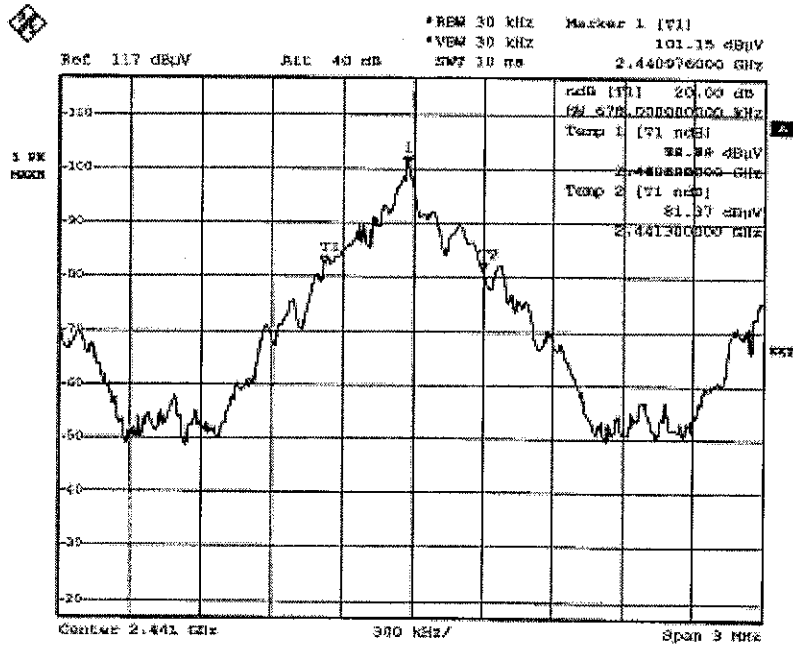

Date: 27.MAY.2003 11:48:28

DATA OF NUMBER OF HOPPING FREQUENCY

UL Apex Co., Ltd.
Head Office EMC Lab. No.3 Measurement Room

COMPANY : Fujitsu Ten Limited
EQUIPMENT : Display
MODEL : 134000-268
S/N : 1G-2 1
FCC ID : BAB134000-268
IC Number : 2024B-134268
POWER : DC12V
MODE : Tx (Hopping on) /Inquiry

REPORT NO : 23JE0007-HO - 9
REGULATION : Fcc Part15 Subpart C 15.247(a)(1)(iii)
TEST DISTANC : -
DATE : 05/27/2003
TEMPERATURE : 24°C
HUMIDITY : 42%

Engineer : Hiroka Umeyama

PK DETECT(S/A : RBW 300kHz ,VBW 1MHz, sweep time AUTO)

Mode	Number of channel [time]	Limit [time]
Tx(Hoppng on)	79	≥ 15

PK DETECT(S/A : RBW 300kHz ,VBW 1MHz, sweep time AUTO)

Mode	Number of channel [time]	Limit [time]
Inquiry	32	≥ 15

Number of Hopping Frequency :Tx(Hopping on)2400-2430MHz

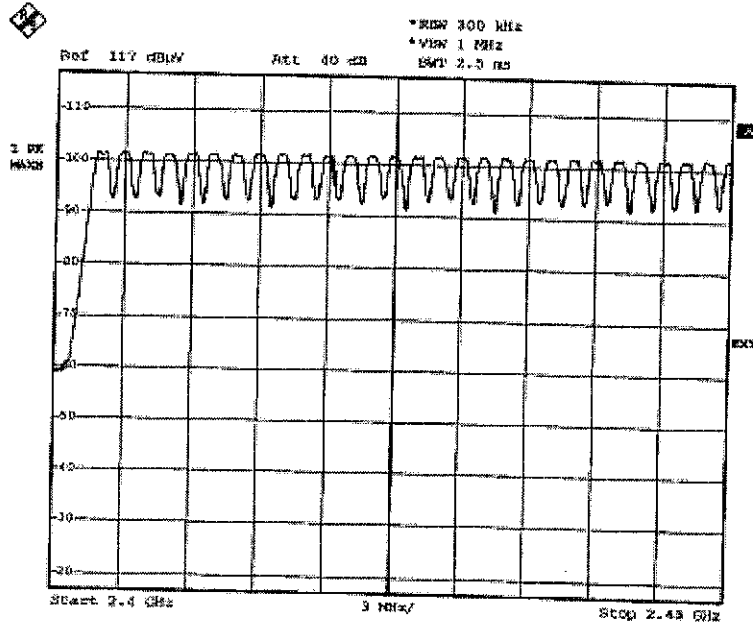

Date: 27-MAY-2003 12:24:05

Number of Hopping Frequency :Tx(Hopping on)2430-2460MHz

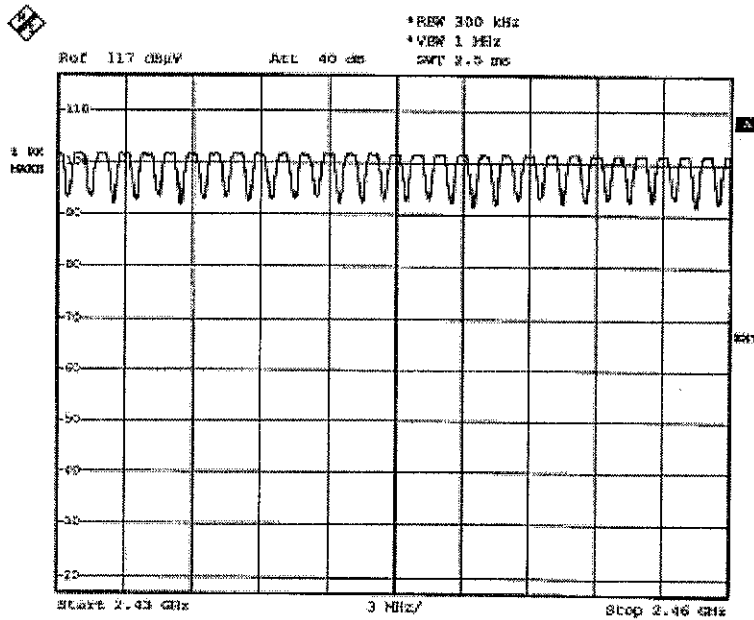

Date: 27-MAY-2003 12:25:35

Number of Hopping Frequency :Tx(Hopping on)2460-2490MHz

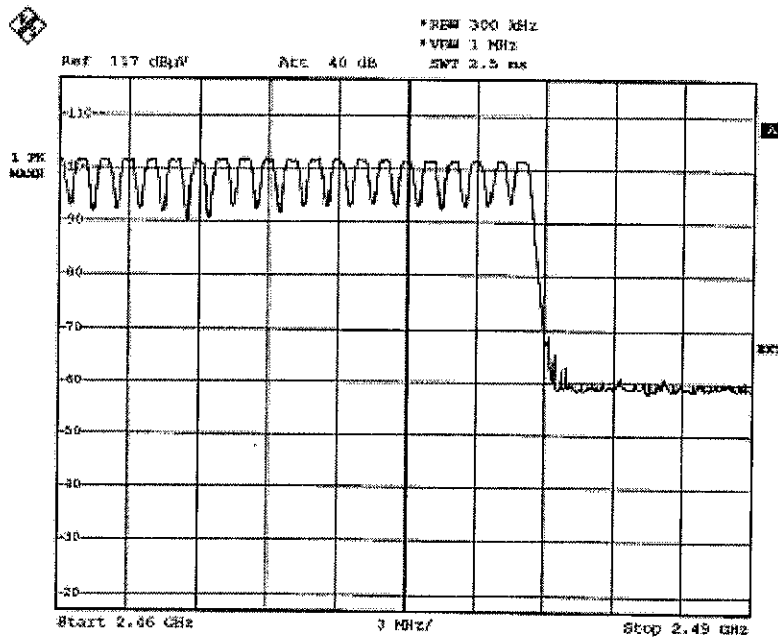

Date: 27.MAY.2003 12:25:37

Number of Hopping Frequency :Inquiry2400-2430MHz

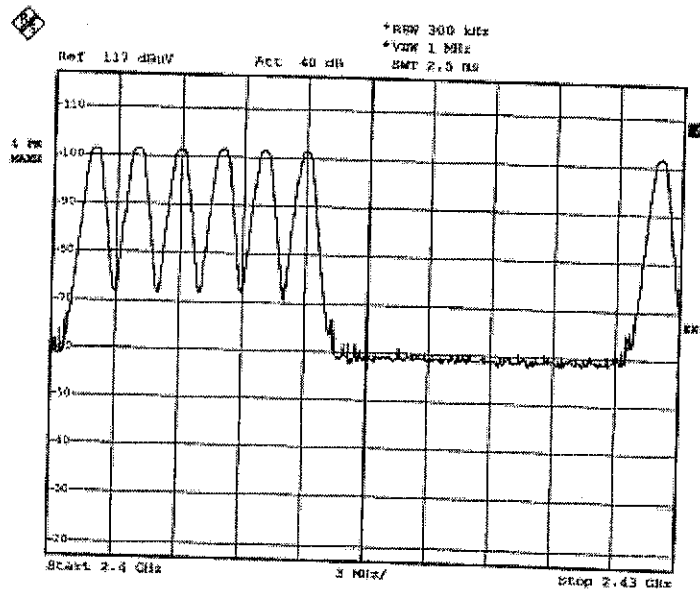

Date: 27.MAY.2003 12:28:16

Number of Hopping Frequency :Inquiry2430-2460MHz

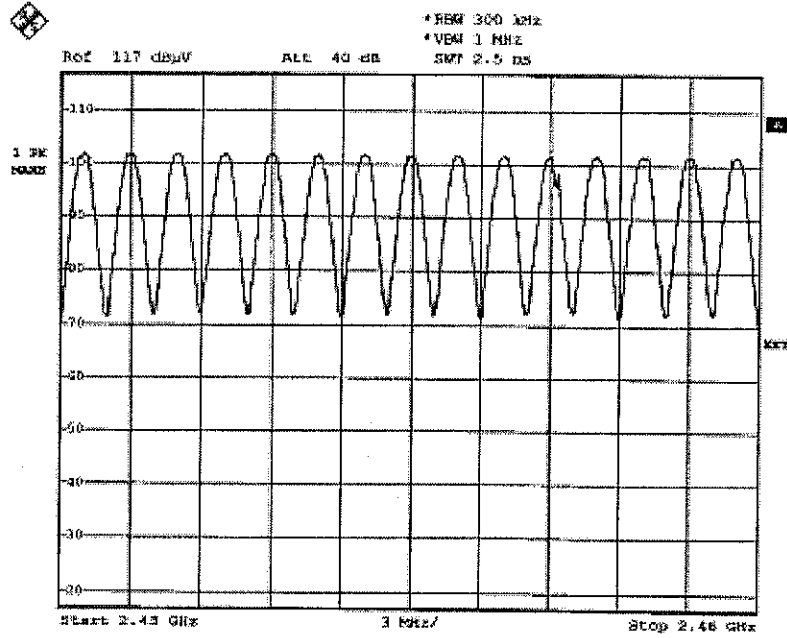

Date: 27.NOV.2003 12:29:48

Number of Hopping Frequency :Inquiry2460-2490MHz

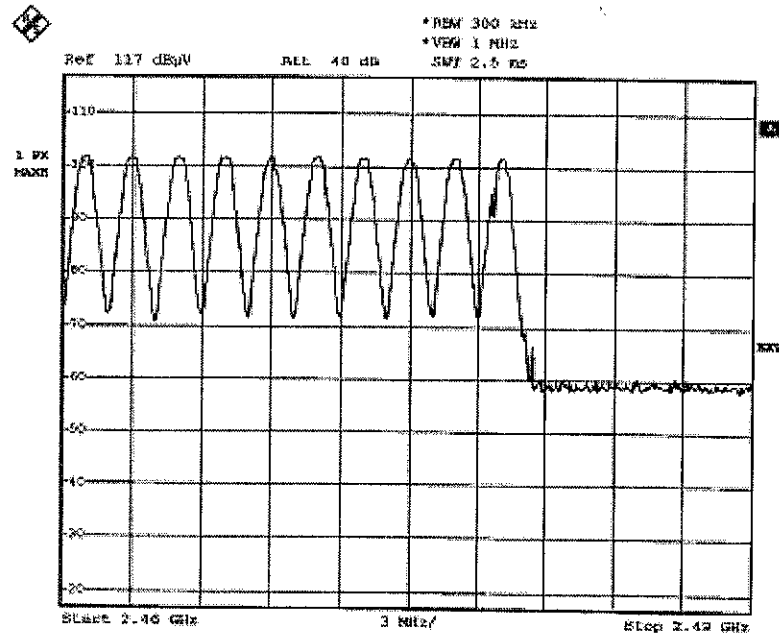

Date: 27.NOV.2003 12:30:53

DATA OF DWELL TIME

UL Apex Co., Ltd.
Head Office EMC Lab. No.3 Measurement Room

COMPANY : Fujitsu Ten Limited	REPORT NO : 23JE0007-HO - 9
EQUIPMENT : Display	REGULATION : Fcc Part15 Subpart C 15.247(a)(1)(iii)
MODEL : 134000-268	TEST DISTANCE : -
S/N : 1G-21	DATE : 05/27/2003
FCC ID : BAB134000-268	TEMPERATURE : 24°C
IC Number : 2024B-134268	HUMIDITY : 42%
POWER : DC12V	
MODE : Tx (Hopping off) /Inquiry	



 Engineer : Hiroka Umeyama

PK DETECT(S/A :span ZERO, RBW 1MHz ,VBW 3MHz, sweep time 1ms-10ms)

Mode	Number of transmission in a 31.6(79 Hopping x 0.4) / 12.8(32 Hopping x 0.4)second period	Length of transmission time [msec]	Result [msec]	Limit [msec]
DH1	50 times /5sec. x 31.6 = 316 times	0.580	183	400
DH3	23 times / 5sec. x 31.6 = 145 times	1.720	249	400
DH5	12 times / 5 sec. x 31.6 = 76 times	2.960	225	400
Inquiry	116 times / 1sec. x 12.8 = 1485 times	0.128	190	400

Dwell time :Tx(Hopping on)DH1(1)

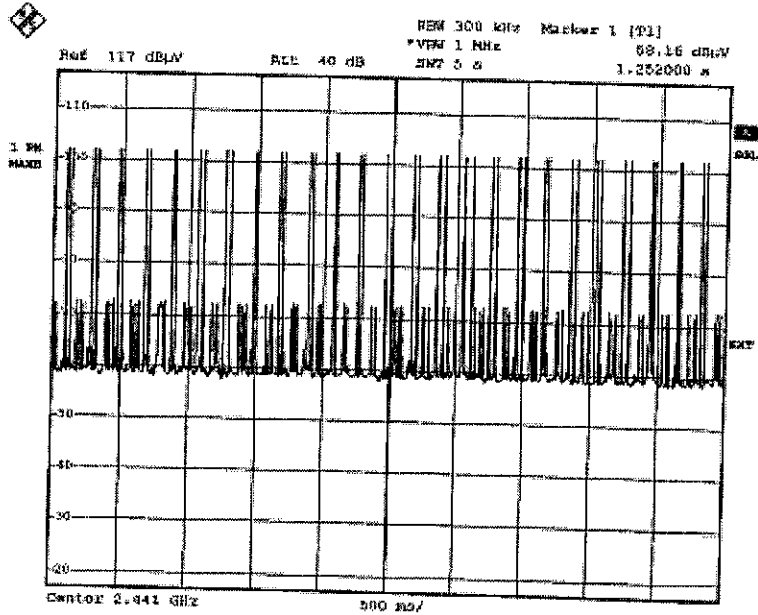

Date: 27.MAY.2003 13:01:19

Dwell time :Tx(Hopping on)DH1(2)

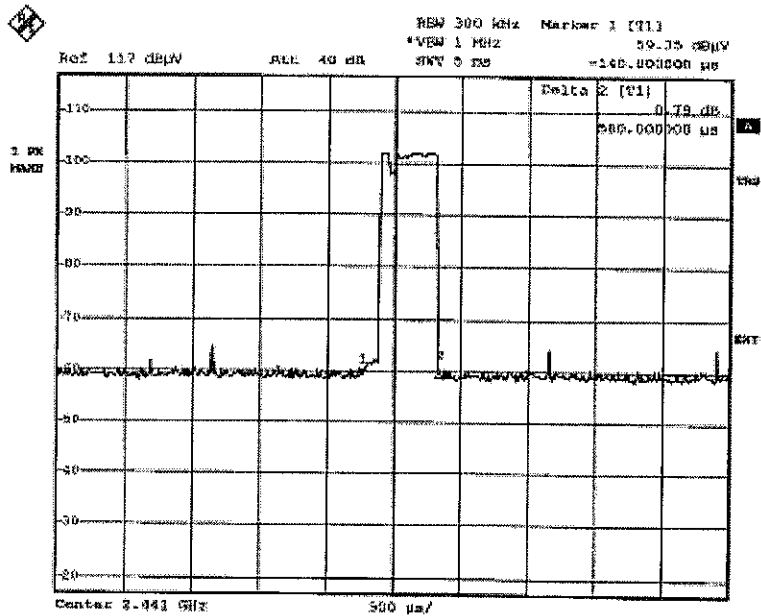

Date: 27.MAY.2003 13:06:42

Dwell time :Tx(Hopping on)DH3(1)

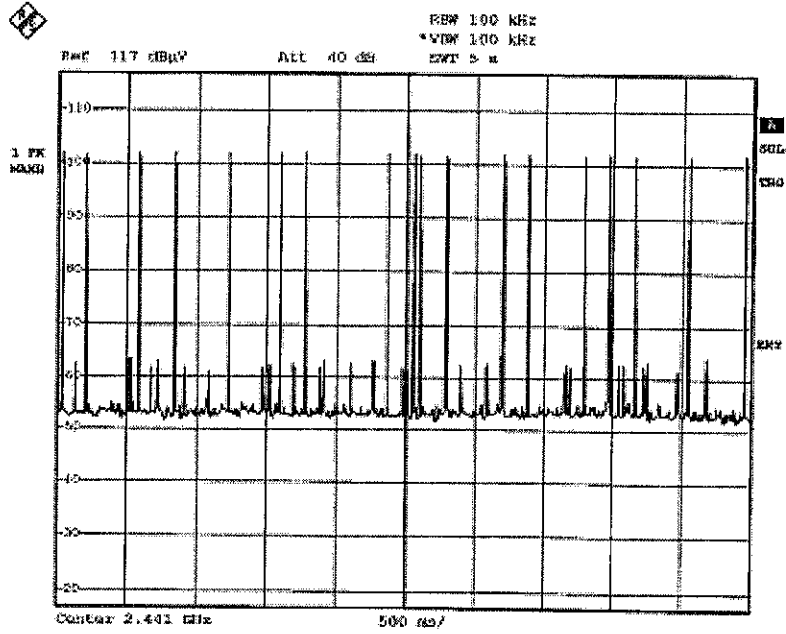

Date: 27.MAY.2003 14:04:05

Dwell time :Tx(Hopping on)DH3(2)

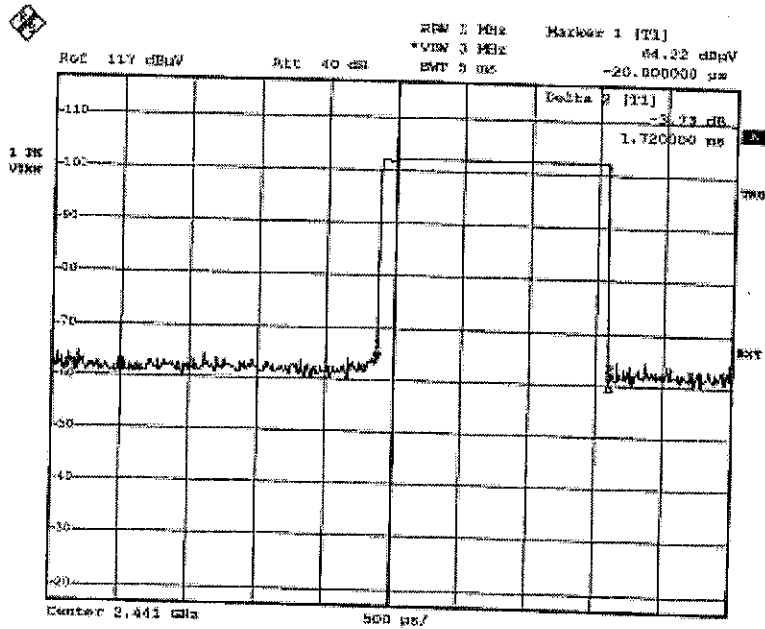

Date: 27.MAY.2003 14:06:55

Dwell time :Tx(Hopping on)DH5(1)

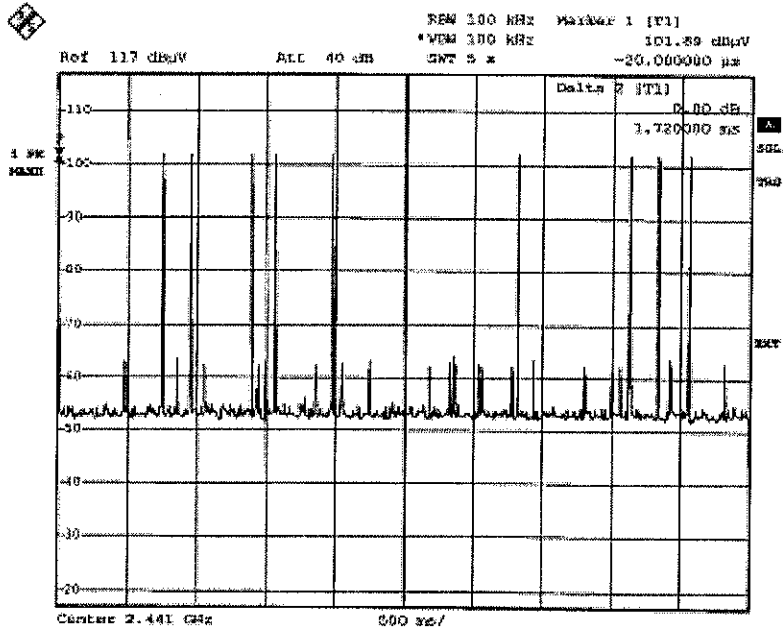

Date: 27.MAY.2003 14:10:05

Dwell time :Tx(Hopping on)DH5(2)

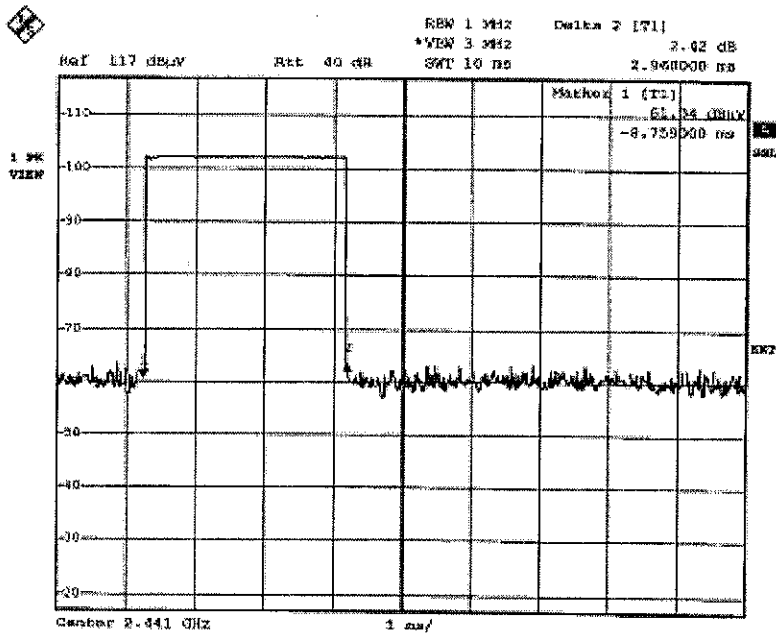

Date: 27.MAY.2003 14:19:22

Dwell time :Inquiry (1)

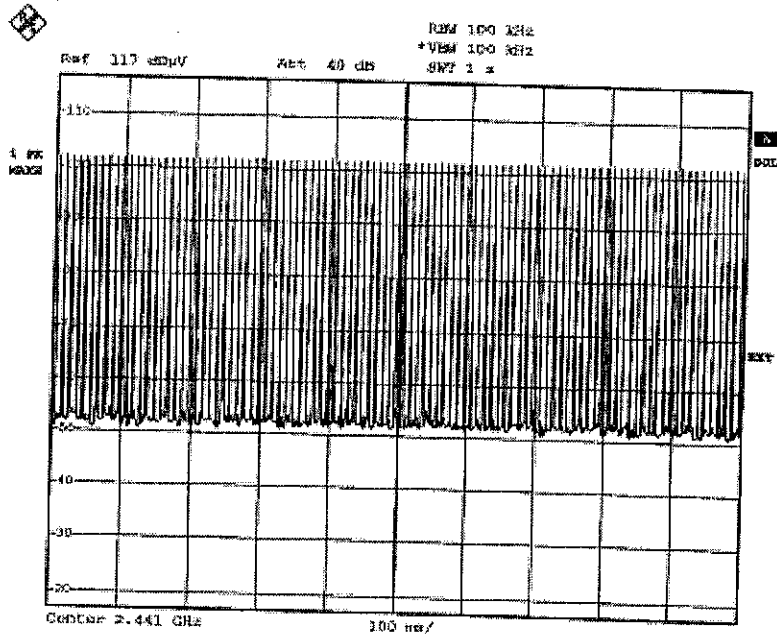

Date: 27.MAY.2003 14:23:11

Dwell time :Inquiry (2)

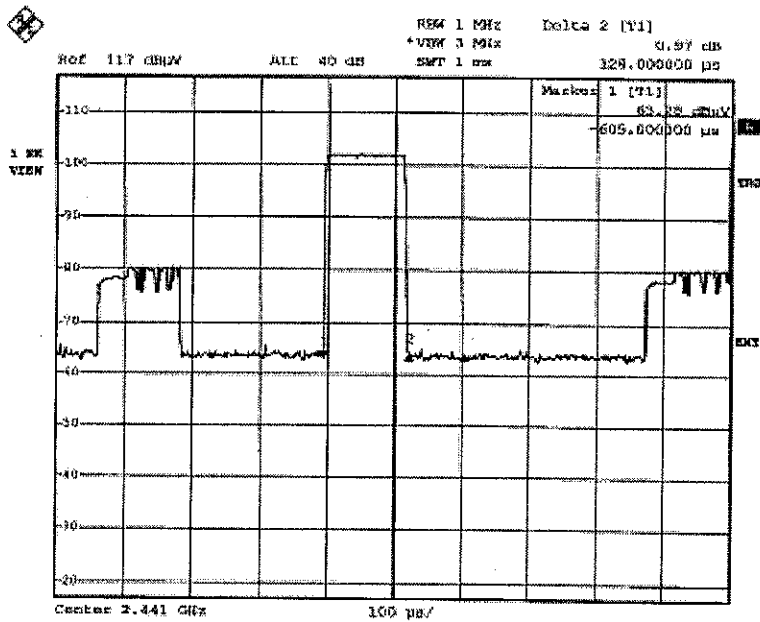

Date: 27.MAY.2003 14:27:05

DATA OF PEAK OUTPUT POWER(CONDUCTED)

UL Apex Co., Ltd.
Head Office EMC Lab. No.3 Measurement Room

COMPANY : Fujitsu Ten Limited
EQUIPMENT : Display
MODEL : 134000-268
S/N : 1G-2 1
FCC ID : BAB134000-268
IC Number : 2024B-134268
POWER : DC12V
MODE : Tx (Hopping off) /Inquiry

REPORT NO : 23JE0007-HO - 9
REGULATION : Fcc Part15 Subpart C 15.247(b)(1)
TEST DISTANCE : -
DATE : 05/27/2003
TEMPERATURE : 24°C
HUMIDITY : 42%

Engineer : Hiroka Umeyama

CH	FREQ [MHz]	S/A Reading [dBm]	Cable Loss [dB]	Result [dBm]	Limit [dBm]
Low	2402.0	-5.25	2.1	-3.15	30.0
Mid	2441.0	-4.99	2.1	-2.89	30.0
High	2480.0	-5.07	2.0	-3.07	30.0
Inquiry	2441.0	-5.01	2.1	-2.91	21.0

Peak Output Power(Conducted):Tx(2402MHz)

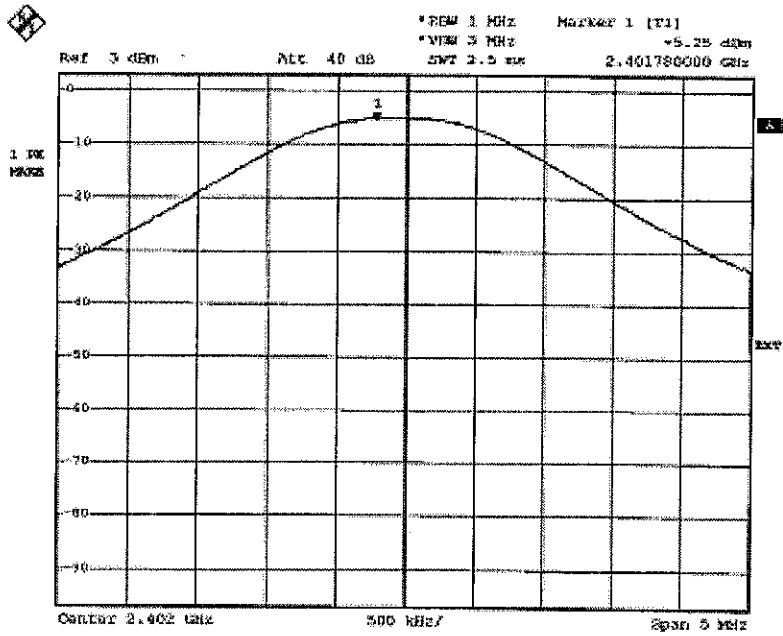

Date: 27.MAY.2003 14:34:55

Peak Output Power(Conducted):Tx(2441MHz)

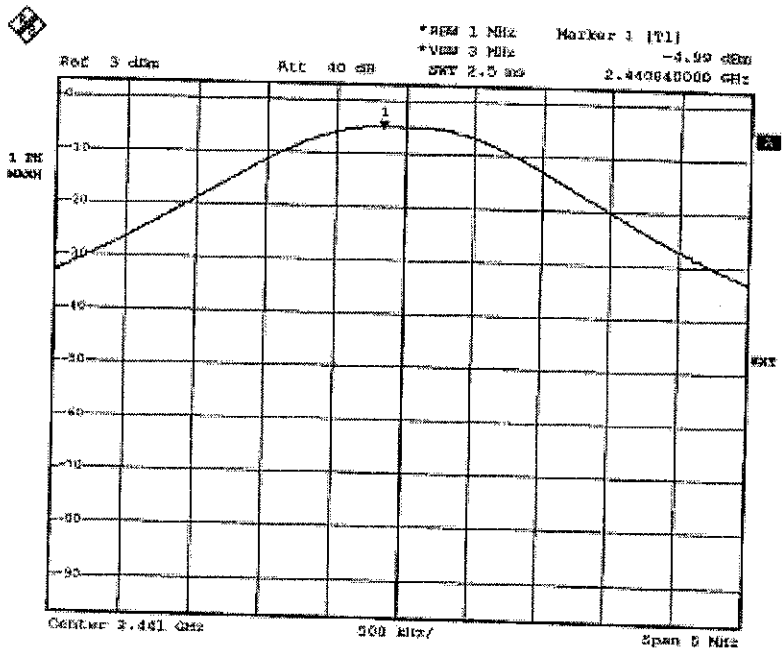

Date: 27.MAY.2003 14:36:52

Peak Output Power(Conducted):Tx(2480MHz)

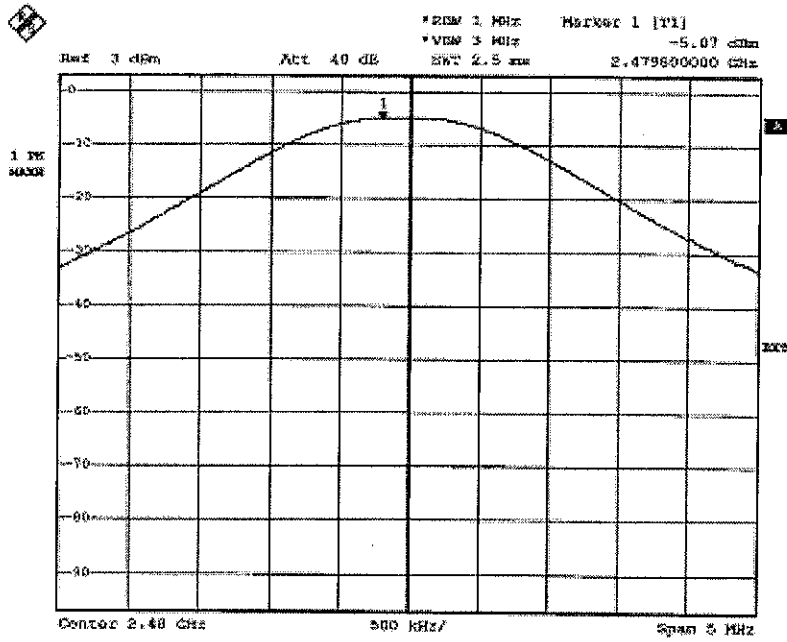

Date: 27.MAY.2003 14:37:34

Peak Output Power(Conducted):Inquiry

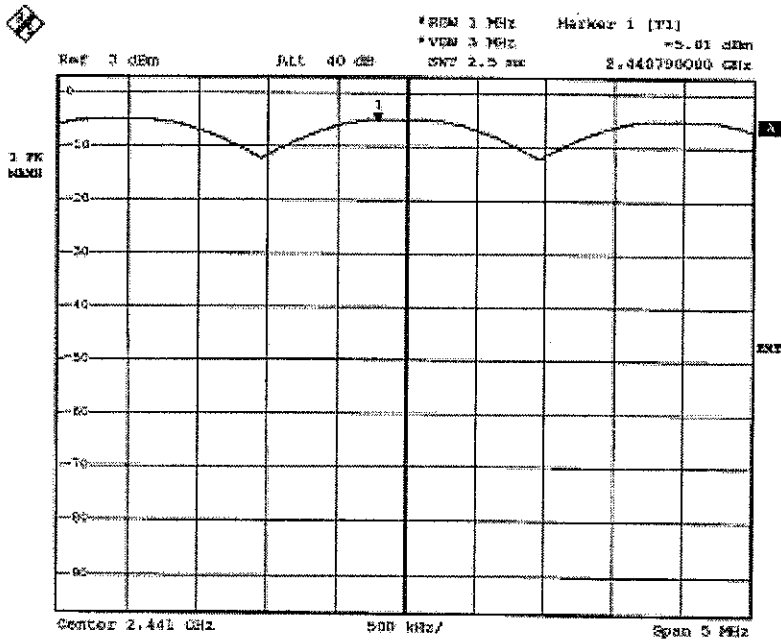

Date: 27.MAY.2003 14:39:45

Band Edge :Tx(Hopping on)2402MHz

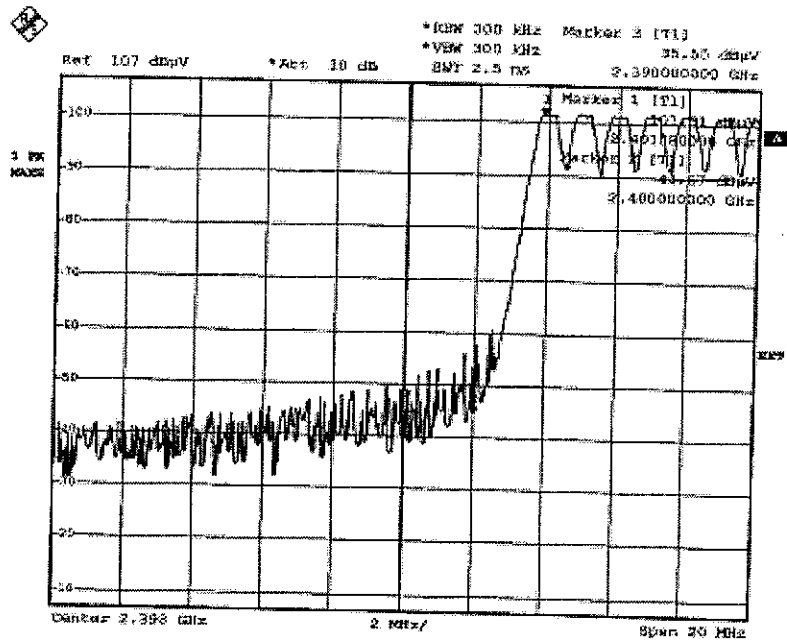

Date: 27.MAY.2003 15:11:05

Band Edge :Tx(Hopping on)2480MHz

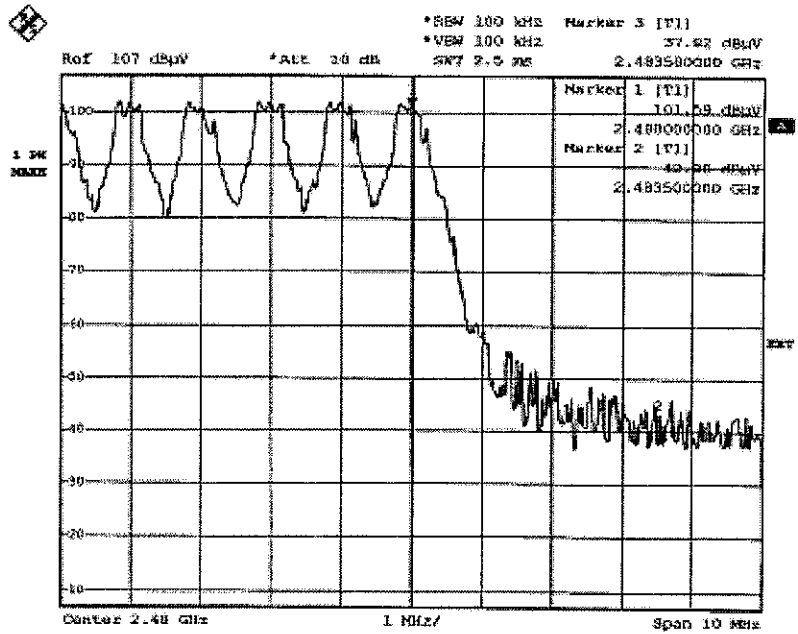

Date: 27.MAY.2003 15:09:04

Band Edge :Tx(Hopping off)2402MHz

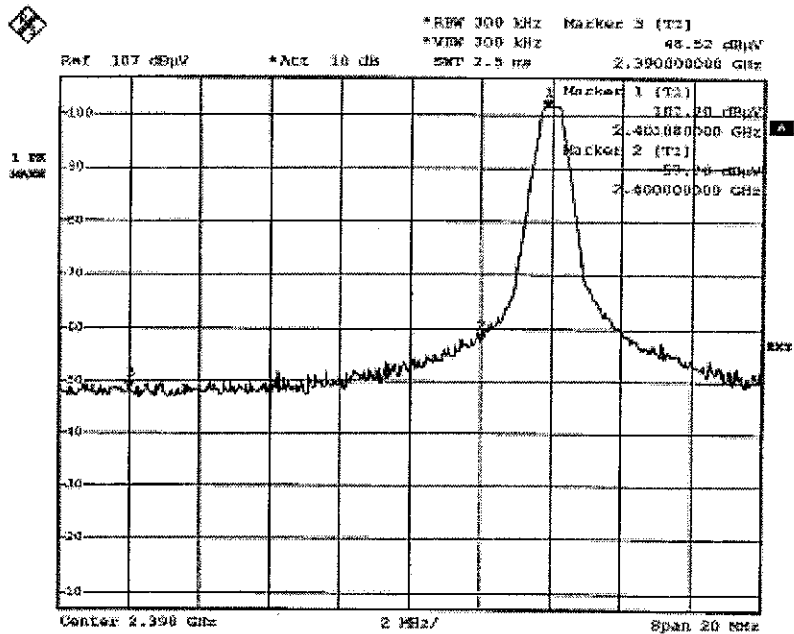

Date: 27.MAY.2003 14:51:44

Band Edge :Tx(Hopping off)2480MHz

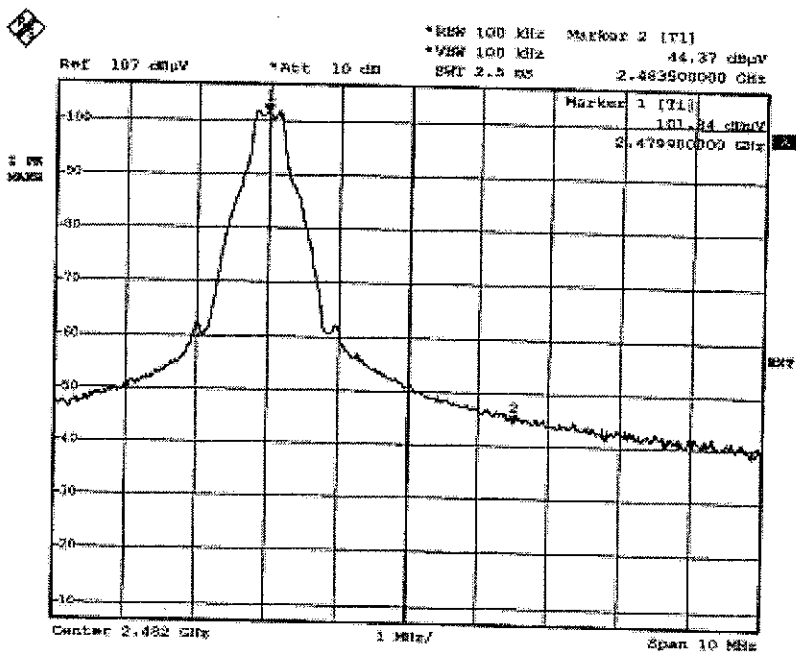

Date: 29.MAY.2003 14:59:38

DATA OF RADIATION TEST

UL Apex Co., Ltd. Head Office EMC Lab.
No.2 Semi Anechoic Chamber
Report No. : 23JE0007-H0 - 9

Applicant : FUJITSU TEN LIMITED
 Kind of Equipment : DISPLAY
 Model No. : 134000-268
 Serial No. : 1G-2 1
 Power : DC 12V
 Mode : Tx(2402MHz)
 Remarks : DETECTOR: QP
 Date : 5/15/2003
 Test Distance : 3 m
 Temperature : 26 °C
 Humidity : 56 %
 Regulation : FCC § 15. 247 (C)

 Engineer : Hiroka Umeyama

No.	FREQ. [MHz]	ANT TYPE	READING		ANT FACTOR [dB/m]	AMP GAIN [dB]	CABLE LOSS [dB]	ATTEN. [dB]	RESULT		LIMITS		MARGIN	
			HOR [dB μ V]	VER					HOR [dB μ V/m]	VER	HOR [dB]	VER		
1.	63.94	BB	26.5	32.6	7.5	27.8	1.0	6.0	13.2	19.3	40.0	26.8	20.7	
2.	95.92	BB	33.0	32.0	9.0	26.9	1.2	6.1	22.4	21.4	43.5	21.1	22.1	
3.	127.89	BB	25.4	30.0	13.8	26.7	1.5	6.0	20.0	24.6	43.5	23.5	18.9	
4.	383.68	BB	26.8	27.7	16.9	27.2	2.6	6.2	25.3	26.2	46.0	20.7	19.8	
5.	479.59	BB	30.6	25.2	18.1	28.1	3.0	6.2	29.8	24.4	46.0	16.2	21.6	
6.	543.54	BB	25.1	31.2	18.8	28.3	3.3	6.1	25.0	31.1	46.0	21.0	14.9	

CALCULATION: READING + ANT. FACTOR + CABLE LOSS - AMP. GAIN + ATTEN.

Except for the above table: adequate margin data below the limits.
 ANT TYPE: 30-300MHz Biconical , 300-1000MHz Logperiodic.

DATA OF RADIATION TEST

UL Apex Co., Ltd. Head Office EMC Lab.
No.2 Semi Anechoic Chamber
Report No. : 23JE0007-HO - 9

Applicant : FUJITSU TEN LIMITED
Kind of Equipment : DISPLAY
Model No. : 134000-268
Serial No. : 1G-2 1
Power : DC 12V
Mode : Tx (2441MHz)
Remarks : DETECTOR: QP
Date : 5/15/2003
Test Distance : 3 m
Temperature : 26 °C
Humidity : 56 %
Regulation : FCC § 15. 247 (C)

Engineer / : Hiroka Umeyama

No.	FREQ. [MHz]	ANT TYPE	READING		ANT FACTOR [dB/m]	AMP GAIN [dB]	CABLE LOSS [dB]	ATTEN. [dB]	RESULT		LIMITS		MARGIN	
			HOR [dB μ V]	VER [dB μ V]					HOR [dB μ V/m]	VER [dB μ V/m]	HOR [dB]	VER [dB]		
1.	63.94	BB	26.4	33.3	7.5	27.8	1.0	6.0	13.1	20.0	40.0	26.9	20.0	
2.	95.92	BB	33.3	32.4	9.0	26.9	1.2	6.1	22.7	21.8	43.5	20.8	21.7	
3.	127.89	BB	26.6	30.2	13.8	26.7	1.5	6.0	21.2	24.8	43.5	22.3	18.7	
4.	383.68	BB	25.6	27.0	16.9	27.2	2.6	6.2	24.1	25.5	46.0	21.9	20.5	
5.	479.59	BB	28.7	25.8	18.1	28.1	3.0	6.2	27.9	25.0	46.0	18.1	21.0	
6.	543.54	BB	25.0	31.0	18.8	28.3	3.3	6.1	24.9	30.9	46.0	21.1	15.1	

CALCULATION: READING + ANT. FACTOR + CABLE LOSS - AMP. GAIN + ATTEN.

Except for the above table: adequate margin data below the limits.
ANT TYPE: 30-300MHz Biconical , 300-1000MHz Logperiodic.

DATA OF RADIATION TEST

UL Apex Co., Ltd. Head Office EMC Lab.
No.2 Semi Anechoic Chamber
Report No. : 23JE0007-H0 - 9

Applicant : FUJITSU TEN LIMITED
 Kind of Equipment : DISPLAY
 Model No. : 134000-268
 Serial No. : 1G-2 1
 Power : DC 12V
 Mode : Tx (2480MHz)
 Remarks : DETECTOR: GP
 Date : 5/15/2003
 Test Distance : 3 m
 Temperature : 26 °C
 Humidity : 56 %
 Regulation : FCC § 15.247(C)

 Engineer : Hiroka Umeyama

No.	FREQ. [MHz]	ANT TYPE	READING		ANT FACTOR [dB/m]	AMP GAIN [dB]	CABLE LOSS [dB]	ATTEN. [dB]	RESULT		LIMITS		MARGIN	
			HOR [dB μ V]	VER					HOR [dB μ V/m]	VER	HOR [dB]	VER		
1.	63.94	BB	27.3	32.6	7.5	27.8	1.0	6.0	14.0	19.3	40.0	26.0	20.7	
2.	95.92	BB	33.1	32.1	9.0	26.9	1.2	6.1	22.5	21.5	43.5	21.0	22.0	
3.	127.89	BB	27.0	30.1	13.8	26.7	1.5	6.0	21.6	24.7	43.5	21.9	18.8	
4.	383.68	BB	25.8	27.3	16.9	27.2	2.6	6.2	24.3	25.8	46.0	21.7	20.2	
5.	479.59	BB	28.6	25.5	18.1	28.1	3.0	6.2	27.8	24.7	46.0	18.2	21.3	
6.	543.54	BB	25.1	30.7	18.8	28.3	3.3	6.1	25.0	30.6	46.0	21.0	15.4	

CALCULATION: READING + ANT. FACTOR + CABLE LOSS - AMP. GAIN + ATTEN.

Except for the above table: adequate margin data below the limits.
 ANT TYPE: 30-300MHz Biconical , 300-1000MHz Logperiodic.

DATA OF SPURIOUS EMISSIONS(1GHz to 26.5GHz)

UL Apex Co., Ltd.
Head Office EMC Lab. No.2 Semi Anechoic Chamber

COMPANY : FUJITSU TEN LIMITED
EQUIPMENT : Display
MODEL : 134000-268
S/N : 1G-2 1
FCC ID : BAB134000-268
IC No : 2024B-134268
POWER : DC 12V
MODE : Tx (2402MHz)

REPORT NO : 23JE0007-HO - 9
REGULATION : FCC Part 15 Subpart C 15.247(c)
TEST DISTANCE : 3 and 1m
DATE : 2003/5/15
TEMPERATURE : 25°C
HUMIDITY : 64%

ENGINEER : Hiroka Umeyama

PK DETECT (RBW: 1MHz, VBW:1MHz)

No.	FREQ [MHz]	S/A READING		ANT Factor [dB/m]	AMP GAIN [dB]	CABLE LOSS [dB]	Band-Pass Filter [dB]	RESULT		Limit PK [dBuV/m]	MARGIN	
		HOR [dBuV/m]	VER [dBuV/m]					HOR [dB]	VER [dB]			
Test distance 3meters RESULT=Reading + ANT Factor - Amp Gain + CABLE LOSS + Band Pass.												
1	1482.5	49.7	44.6	24.1	37.3	3.5	0.0	39.9	34.8	74.0	34.1	39.2
2	2390.0	45.8	46.0	30.5	36.9	4.4	0.0	43.8	44.0	74.0	30.2	30.0
4	4804.0	53.8	48.2	35.5	36.8	6.4	0.0	58.9	53.3	74.0	15.1	20.7
5	7206.0	45.3	44.4	37.6	36.5	7.6	0.0	54.1	53.2	74.0	19.9	20.8
6	9608.0	45.3	46.4	37.3	37.2	8.9	0.0	54.3	55.4	74.0	19.7	18.6
Test distance 1meters RESULT=Reading + ANT Factor - Amp Gain + CABLE LOSS + Band Pass - Dfac												
7	12010.0	45.5	45.6	40.1	36.8	9.9	0.0	49.1	49.2	74.0	24.9	24.8
8	14412.0	44.6	45.1	43.0	35.3	11.0	0.0	53.8	54.4	74.0	20.2	19.6
9	16814.0	47.5	47.4	44.7	36.5	12.2	0.0	58.3	58.3	74.0	15.7	15.7
10	19216.0	46.2	46.7	41.0	35.8	13.0	0.0	54.8	55.3	74.0	19.2	18.7
11	21618.0	47.1	47.7	40.5	36.8	14.1	0.0	55.4	56.0	74.0	18.6	18.0
12	24020.0	46.3	47.0	40.2	36.4	14.7	0.0	55.3	56.1	74.0	18.7	17.9

AV DETECT (RBW: 1MHz, VBW:10Hz)

No.	FREQ [MHz]	S/A READING		ANT Factor [dB/m]	AMP GAIN [dB]	CABLE LOSS [dB]	Band-Pass Filter [dB]	RESULT		Limit AV [dBuV/m]	MARGIN	
		HOR [dBuV/m]	VER [dBuV/m]					HOR [dB]	VER [dB]			
Test distance 3meters RESULT=Reading + ANT Factor - Amp Gain + CABLE LOSS + Band Pass.												
1	1482.5	38.6	36.0	24.1	37.3	3.5	0.0	28.8	26.3	54.0	25.2	27.7
2	2390.0	33.7	33.7	30.5	36.9	4.4	0.0	31.7	31.7	54.0	22.3	22.3
4	4804.0	37.3	28.1	35.5	36.8	6.4	0.0	42.4	33.2	54.0	11.6	20.8
5	7206.0	32.0	31.9	37.6	36.5	7.6	0.0	40.8	40.6	54.0	13.2	13.4
6	9608.0	33.3	33.2	37.3	37.2	8.9	0.0	42.4	42.3	54.0	11.6	11.7
Test distance 1meters RESULT=Reading + ANT Factor - Amp Gain + CABLE LOSS + Band Pass - Dfac												
7	12010.0	32.7	33.0	40.1	36.8	9.9	0.0	36.3	36.6	54.0	17.7	17.4
8	14412.0	32.0	32.5	43.0	35.3	11.0	0.0	41.2	41.7	54.0	12.8	12.3
9	16814.0	33.6	33.5	44.7	36.5	12.2	0.0	44.5	44.4	54.0	9.5	9.6
10	19216.0	33.7	34.1	41.0	35.8	13.0	0.0	42.3	42.7	54.0	11.7	11.3
11	21618.0	34.5	34.7	40.5	36.8	14.1	0.0	42.8	43.0	54.0	11.2	11.0
12	24020.0	34.4	34.5	40.2	36.4	14.7	0.0	43.4	43.5	54.0	10.6	10.5

Test Distance 1.0m : Distance Factor(Dfac) = 20log(3/1.0) =

9.5 dB

*1: Except for the above table : All other spurious emissions were less than 20dB for the limit.

*2: In the frequency over the fourth harmonic, the noise from the EUT was not seen. The data above is its base noise.

DATA OF SPURIOUS EMISSIONS(1GHz to 26.5GHz)

UL Apex Co., Ltd.
Head Office EMC Lab. No.2 Semi Anechoic Chamber

COMPANY : FUJITSU TEN LIMITED
EQUIPMENT : Display
MODEL : 134000-268
S/N : 1G-2 1
FCC ID : BAB134000-268
IC No : 2024B-134268
POWER : DC 12V
MODE : Tx (2441MHz)

REPORT NO : 23JE0007-HO - 9
REGULATION : FCC Part 15 Subpart C 15.247(c)
TEST DISTANCE : 3 and 1m
DATE : 2003/5/15
TEMPERATURE : 25°C
HUMIDITY : 64%

ENGINEER : Hiroka Umeyama

PK DETECT (RBW: 1MHz , VBW:1MHz)

No.	FREQ [MHz]	S/A READING		ANT Factor [dB/m]	AMP GAIN [dB]	CABLE LOSS [dB]	Band-Pass Filter [dB]	RESULT		Limit PK [dBuV/m]	MARGIN	
		HOR [dBuV/m]	VER [dBuV/m]					HOR [dB]	VER [dB]			
Test distance 3meters RESULT=Reading + ANT Factor - Amp Gain + CABLE LOSS + Band Pass.												
1	1482.5	49.2	51.9	24.1	37.3	3.5	0.0	39.5	42.2	74.0	34.5	31.8
2	2390.0	46.7	46.8	30.5	36.9	4.4	0.0	44.7	44.8	74.0	29.3	29.2
4	4882.0	49.1	49.5	36.0	36.8	6.4	0.0	54.8	55.1	74.0	19.2	18.9
5	7323.0	45.3	45.8	37.8	36.6	7.6	0.0	54.2	54.6	74.0	19.8	19.4
6	9764.0	46.1	47.0	36.9	37.2	9.0	0.0	54.7	55.6	74.0	19.3	18.4
Test distance 1meters RESULT=Reading + ANT Factor - Amp Gain + CABLE LOSS + Band Pass - Dfac												
7	12205.0	44.8	45.4	41.1	36.7	10.0	0.0	49.7	50.3	74.0	24.3	23.7
8	14646.0	45.0	45.3	43.2	35.5	11.1	0.0	54.3	54.6	74.0	19.7	19.4
9	17087.0	46.4	47.4	44.9	36.2	12.3	0.0	57.9	58.8	74.0	16.1	15.2
10	19528.0	46.6	46.1	40.5	36.0	13.0	0.0	54.7	54.1	74.0	19.3	19.9
11	21969.0	46.8	46.9	40.6	36.0	14.3	0.0	56.3	56.4	74.0	17.7	17.6
12	24410.0	46.9	46.5	40.4	36.9	14.9	0.0	55.7	55.3	74.0	18.3	18.7

AV DETECT (RBW: 1MHz , VBW:10Hz)

No.	FREQ [MHz]	S/A READING		ANT Factor [dB/m]	AMP GAIN [dB]	CABLE LOSS [dB]	Band-Pass Filter [dB]	RESULT		Limit AV [dBuV/m]	MARGIN	
		HOR [dBuV/m]	VER [dBuV/m]					HOR [dB]	VER [dB]			
Test distance 3meters RESULT=Reading + ANT Factor - Amp Gain + CABLE LOSS + Band Pass.												
1	1482.5	38.3	41.0	24.1	37.3	3.5	0.0	28.5	31.3	54.0	25.5	22.7
2	2390.0	33.8	33.8	30.5	36.9	4.4	0.0	31.8	31.8	54.0	22.2	22.2
4	4882.0	33.8	34.0	36.0	36.8	6.4	0.0	39.5	39.6	54.0	14.5	14.4
5	7323.0	32.3	32.3	37.8	36.6	7.6	0.0	41.2	41.2	54.0	12.8	12.8
6	9764.0	33.7	33.7	36.9	37.2	9.0	0.0	42.3	42.3	54.0	11.7	11.7
Test distance 1meters RESULT=Reading + ANT Factor - Amp Gain + CABLE LOSS + Band Pass - Dfac												
7	12205.0	32.7	32.7	41.1	36.7	10.0	0.0	37.5	37.6	54.0	16.5	16.4
8	14646.0	32.0	32.5	43.2	35.5	11.1	0.0	41.3	41.8	54.0	12.7	12.2
9	17087.0	32.4	32.4	44.9	36.2	12.3	0.0	43.9	43.9	54.0	10.1	10.1
10	19528.0	33.8	33.5	40.5	36.0	13.0	0.0	41.9	41.6	54.0	12.1	12.4
11	21969.0	34.2	33.9	40.6	36.0	14.3	0.0	43.6	43.4	54.0	10.4	10.6
12	24410.0	34.2	34.3	40.4	36.9	14.9	0.0	43.0	43.1	54.0	11.0	10.9

Test Distance 1.0m : Distance Factor(Dfac) = $20\log(3/1.0) =$

9.5 dB

*1: Except for the above table : All other spurious emissions were less than 20dB for the limit.

*2: In the frequency over the fourth harmonic, the noise from the EUT was not seen. The data above is its base noise.

DATA OF SPURIOUS EMISSIONS(1GHz to 26.5GHz)

UL Apex Co., Ltd.
Head Office EMC Lab. No.2 Semi Anechoic Chamber

COMPANY : FUJITSU TEN LIMITED
EQUIPMENT : Display
MODEL : 134000-268
S/N : 1G-2 1
FCC ID : BAB134000-268
IC No : 2024B-134268
POWER : DC 12V
MODE : Tx (2480MHz)

REPORT NO : 23JE0007-HO - 9
REGULATION : FCC Part 15 Subpart C 15.247(c)
TEST DISTANCE : 3 and 1m
DATE : 2003/5/15
TEMPERATURE : 25°C
HUMIDITY : 64%

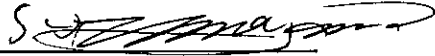
ENGINEER : Hiroka Umeyama

PK DETECT (RBW: 1MHz , VBW:1MHz)

No.	FREQ [MHz]	S/A READING		ANT Factor [dB/m]	AMP GAIN [dB]	CABLE LOSS [dB]	Band-Pass Filter [dB]	RESULT		Limit PK [dBuV/m]	MARGIN	
		HOR [dBuV/m]	VER [dBuV/m]					HOR [dB]	VER [dB]			
Test distance 3meters RESULT=Reading + ANT Factor - Amp Gain + CABLE LOSS + Band Pass.												
1	1482.5	50.9	52.7	24.1	37.3	3.5	0.0	41.1	42.9	74.0	32.9	31.1
2	2483.5	58.8	57.7	30.6	36.9	4.5	0.0	56.9	55.9	74.0	17.1	18.1
4	4960.0	49.0	49.3	36.5	36.8	6.5	0.0	55.3	55.5	74.0	18.7	18.5
5	7440.0	45.1	45.8	37.9	36.7	7.7	0.0	54.1	54.7	74.0	19.9	19.3
6	9920.0	47.1	46.9	36.4	37.3	9.1	0.0	55.3	55.2	74.0	18.7	18.8
Test distance 1meters RESULT=Reading + ANT Factor - Amp Gain + CABLE LOSS + Band Pass - Dfac												
7	12400.0	45.5	45.6	42.1	36.6	10.1	0.0	51.6	51.6	74.0	22.4	22.4
8	14880.0	45.2	44.7	43.4	35.7	11.2	0.0	54.6	54.1	74.0	19.4	19.9
9	17360.0	46.4	46.6	45.9	36.2	12.4	0.0	59.1	59.3	74.0	14.9	14.7
10	19840.0	46.1	47.6	40.7	36.1	13.1	0.0	54.4	55.8	74.0	19.6	18.2
11	22320.0	45.7	47.3	40.7	35.5	14.4	0.0	55.7	57.3	74.0	18.3	16.7
12	24800.0	47.1	46.8	40.4	36.7	15.1	0.0	56.3	56.1	74.0	17.7	17.9

AV DETECT (RBW: 1MHz , VBW:10Hz)

No.	FREQ [MHz]	S/A READING		ANT Factor [dB/m]	AMP GAIN [dB]	CABLE LOSS [dB]	Band-Pass Filter [dB]	RESULT		Limit AV [dBuV/m]	MARGIN	
		HOR [dBuV/m]	VER [dBuV/m]					HOR [dB]	VER [dB]			
Test distance 3meters RESULT=Reading + ANT Factor - Amp Gain + CABLE LOSS + Band Pass.												
1	1482.5	43.9	44.2	24.1	37.3	3.5	0.0	34.1	34.5	54.0	19.9	19.5
2	2483.5	39.7	39.5	30.6	36.9	4.5	0.0	37.9	37.6	54.0	16.1	16.4
4	4960.0	34.9	35.4	36.5	36.8	6.5	0.0	41.2	41.7	54.0	12.8	12.3
5	7440.0	32.4	32.4	37.9	36.7	7.7	0.0	41.4	41.4	54.0	12.6	12.6
6	9920.0	33.9	33.9	36.4	37.3	9.1	0.0	42.1	42.2	54.0	11.9	11.8
Test distance 1meters RESULT=Reading + ANT Factor - Amp Gain + CABLE LOSS + Band Pass - Dfac												
7	12400.0	33.3	32.9	42.1	36.6	10.1	0.0	39.4	39.0	54.0	14.6	15.0
8	14880.0	33.0	32.5	43.4	35.7	11.2	0.0	42.4	41.9	54.0	11.6	12.1
9	17360.0	31.4	31.5	45.9	36.2	12.4	0.0	44.1	44.1	54.0	9.9	9.9
10	19840.0	34.4	34.7	40.7	36.1	13.1	0.0	42.7	43.0	54.0	11.3	11.0
11	22320.0	33.8	34.0	40.7	35.5	14.4	0.0	43.8	44.0	54.0	10.2	10.0
12	24800.0	34.4	34.5	40.4	36.7	15.1	0.0	43.6	43.7	54.0	10.4	10.3

Test Distance 1.0m : Distance Factor(Dfac) = $20\log(3/1.0) = 9.5$ dB

*1: Except for the above table : All other spurious emissions were less than 20dB for the limit.

*2: In the frequency over the fourth harmonic, the noise from the EUT was not seen. The data above is its base noise.

Spurious Emission(Conducted) :Tx(2402MHz)

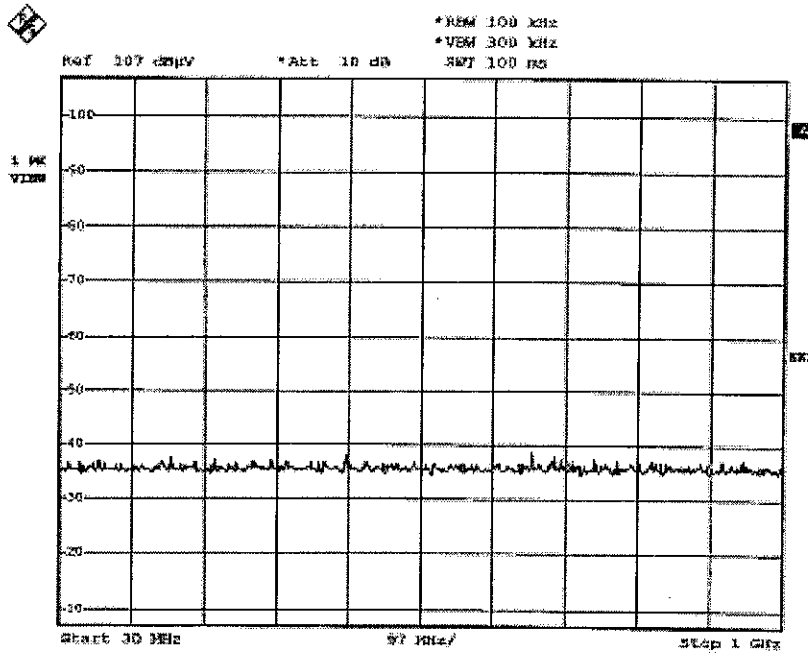

Date: 27.MAY.2003 15:16:19

Spurious Emission(Conducted) :Tx(2402MHz)

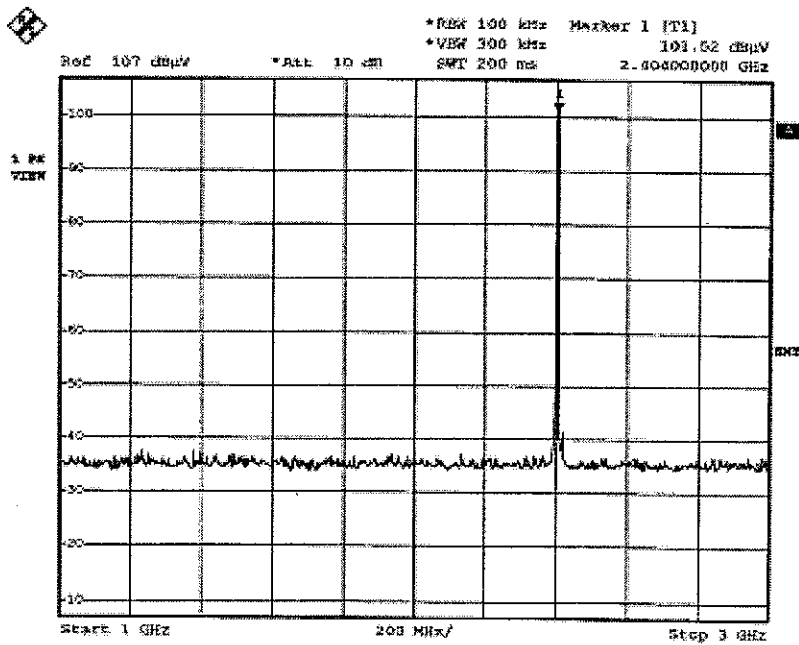

Date: 27.MAY.2003 15:17:18

Spurious Emission(Conducted) :Tx(2402MHz)

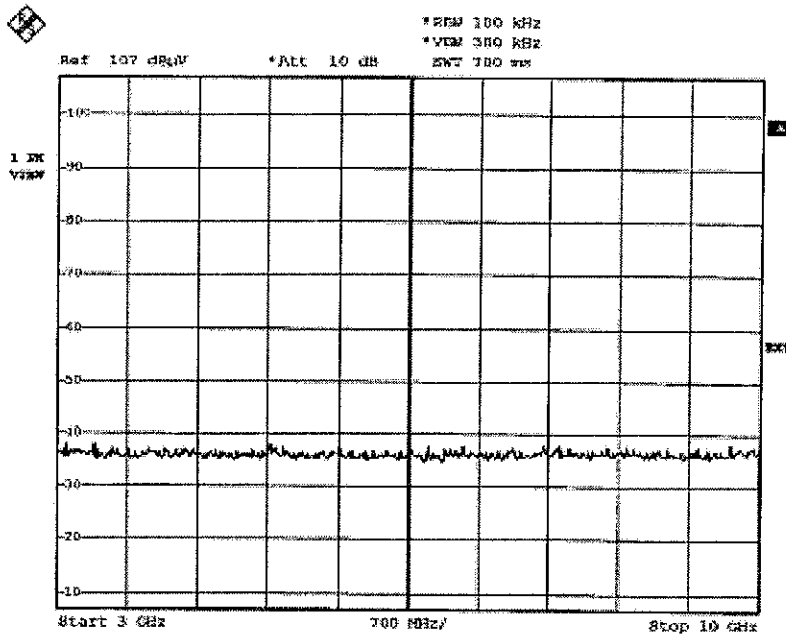

Date: 27.MAY.2003 15:18:27

Spurious Emission(Conducted) :Tx(2402MHz)

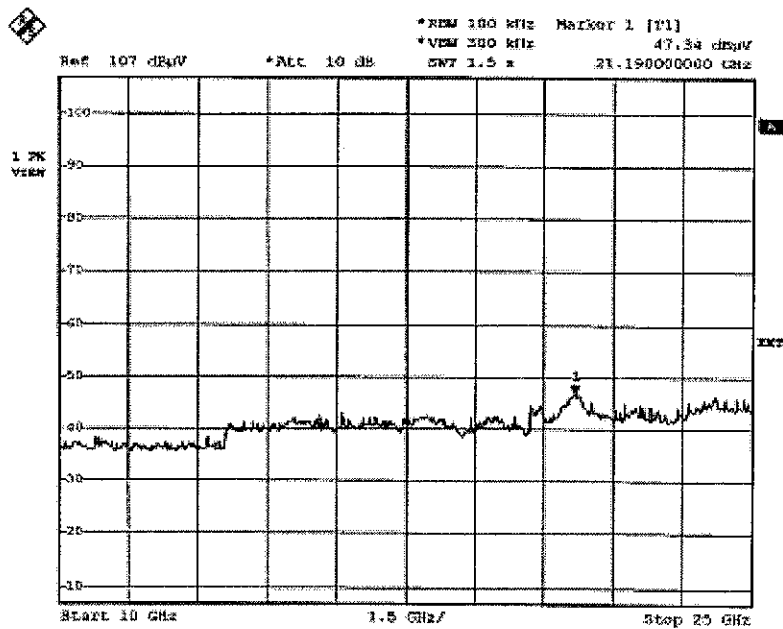

Date: 27.MAY.2003 15:19:20

Spurious Emission(Conducted) :Tx(2441MHz)

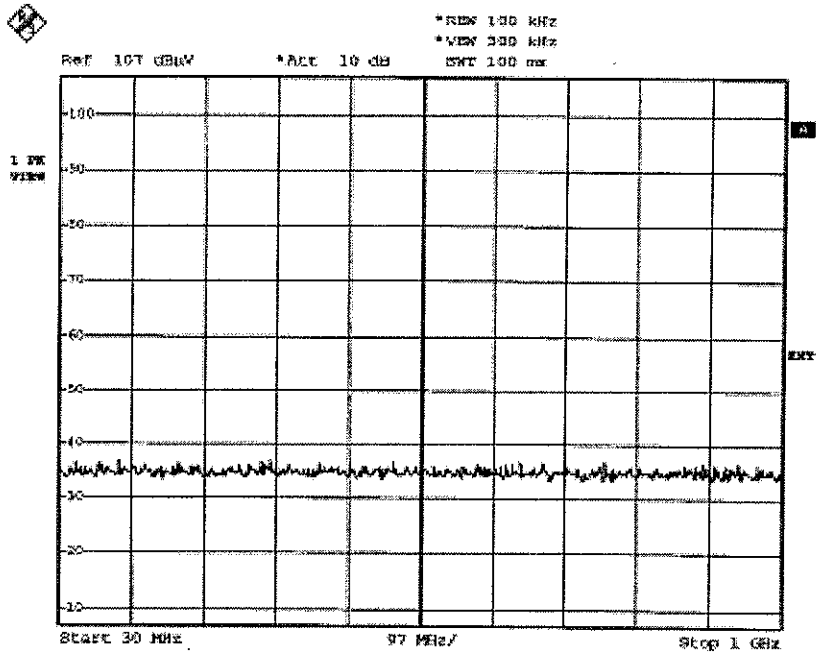

Date: 27.MAY.2003 15:22:23

Spurious Emission(Conducted) :Tx(2441MHz)

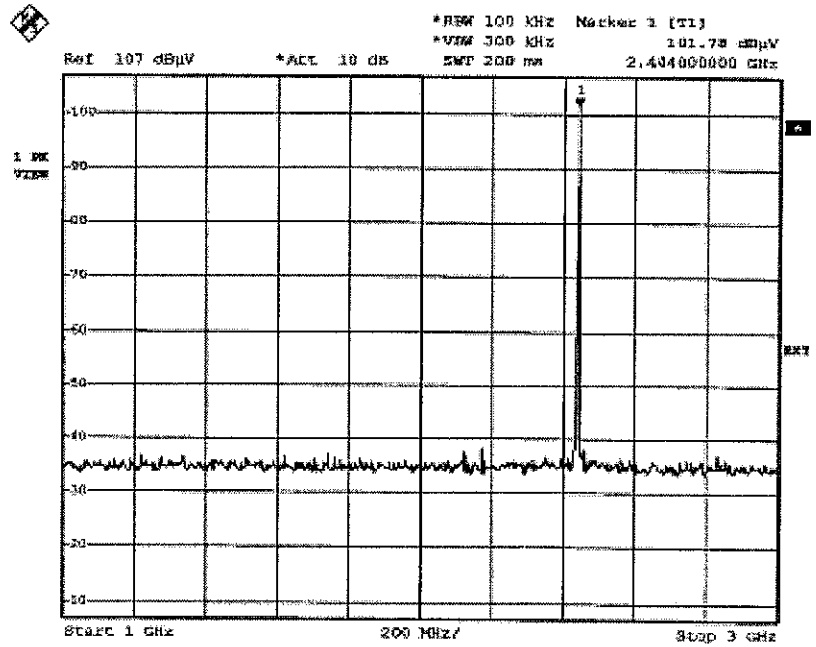

Date: 27.MAY.2003 15:23:06

Spurious Emission(Conducted) :Tx(2441MHz)

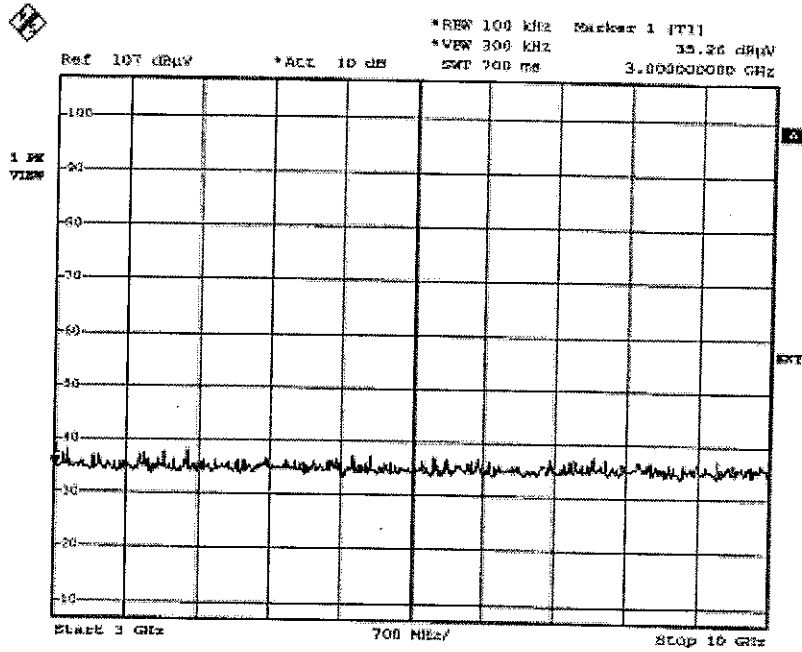

Date: 27.MAY.2003 15:23:36

Spurious Emission(Conducted) :Tx(2441MHz)

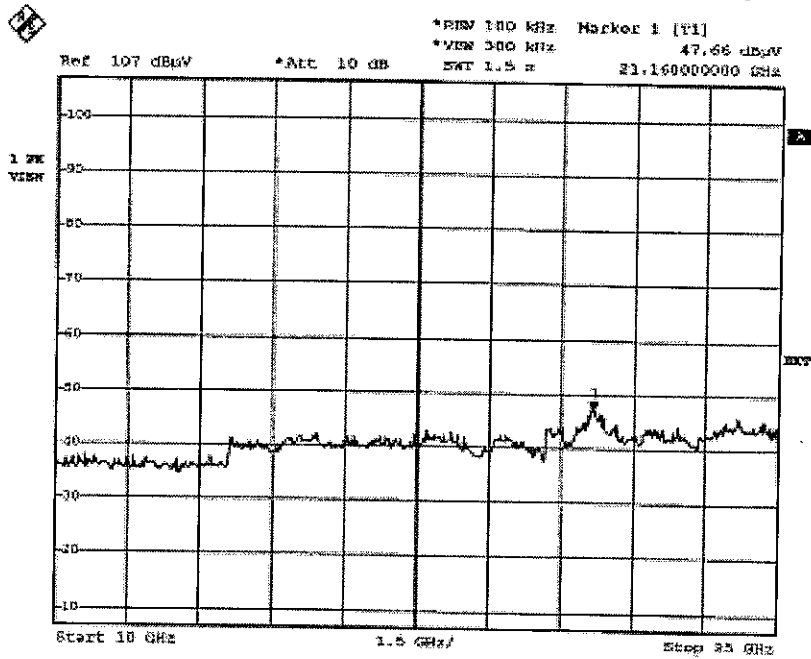

Date: 27.MAY.2003 15:24:11

Spurious Emission(Conducted) :Tx(2480MHz)

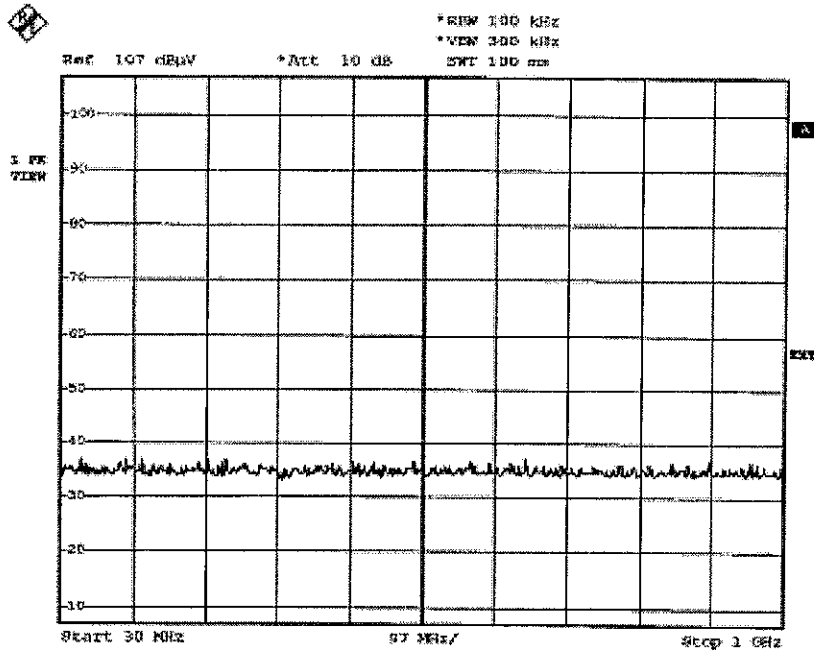

Date: 27.MAY.2003 15:24:51

Spurious Emission(Conducted) :Tx(2480MHz)

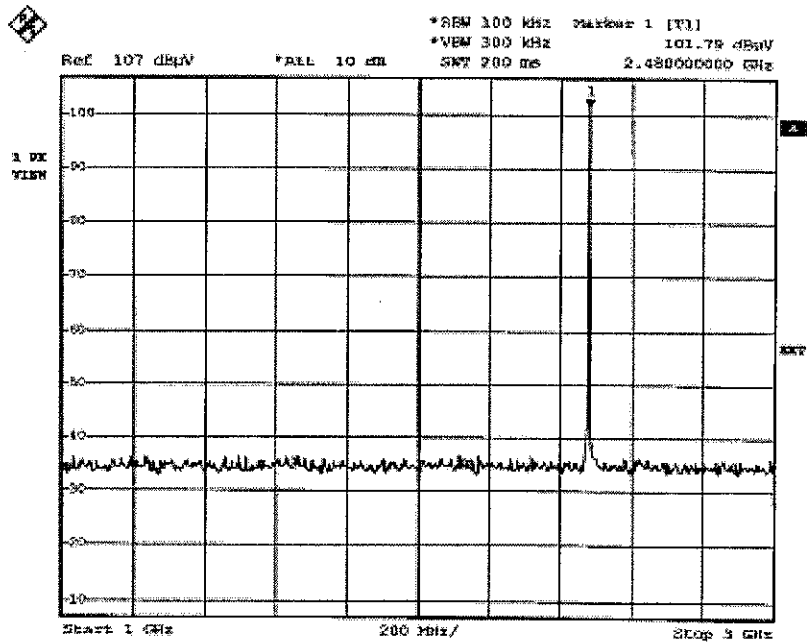

Date: 27.MAY.2003 15:25:15

Spurious Emission(Conducted) :Tx(2480MHz)

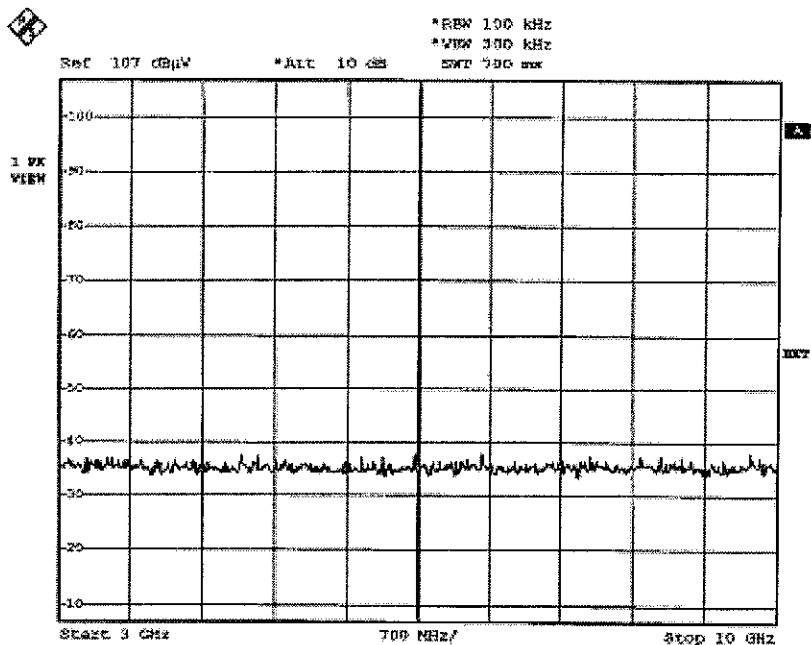

Date: 27.MAY.2003 15:25:54

Spurious Emission(Conducted) :Tx(2480MHz)

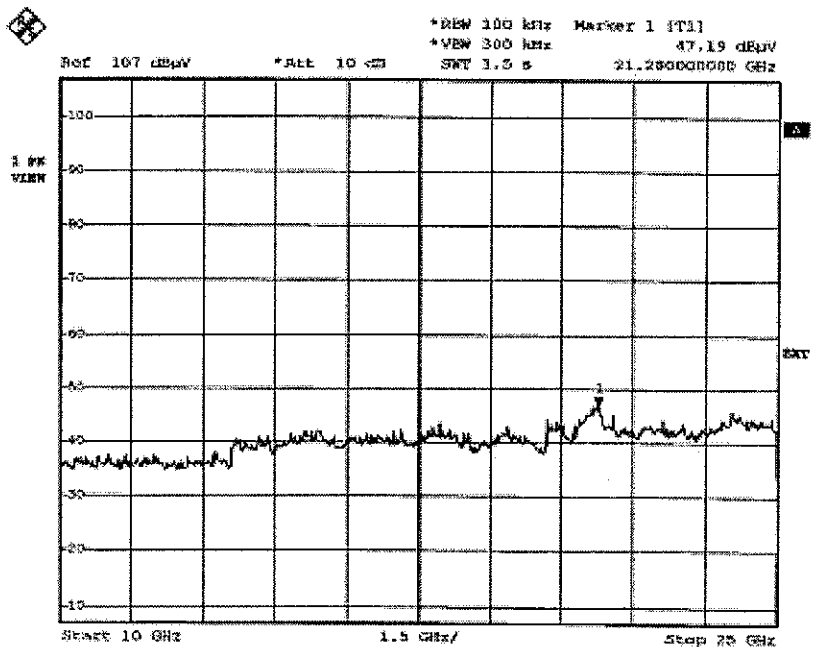

Date: 27.MAY.2003 15:26:20